

CHANGE REQUEST		Please see embedded help file at the bottom of this page for instructions on how to fill in this form correctly.	
03.33	CR	Current Version:	8.0.0
GSM (AA.BB) or 3G (AA.BBB) specification number ↑	↑ CR number as allocated by MCC support team		
For submission to: <input style="width: 100px;" type="text"/> <small>list expected approval meeting # here ↑</small>	for approval for information <input checked="" type="checkbox"/>	strategic <input type="checkbox"/> non-strategic <input type="checkbox"/>	(for SMG use only)

Form: CR cover sheet, version 2 for 3GPP and SMG The latest version of this form is available from: ftp://ftp.3gpp.org/Information/CR-Form-v2.doc

Proposed change affects: (U)SIM ME UTRAN / Radio Core Network
(at least one should be marked with an X)

Source: S3 LI **Date:** 2000-11-16

Subject: Deletion of mono-mode and addition of optimal routing

Work item: Lawful Interception stage 2

Category:	F Correction <input type="checkbox"/> A Corresponds to a correction in an earlier release <input type="checkbox"/> B Addition of feature <input type="checkbox"/> C Functional modification of feature <input checked="" type="checkbox"/> D Editorial modification <input type="checkbox"/>	Release:	Phase 2 <input type="checkbox"/> Release 96 <input type="checkbox"/> Release 97 <input type="checkbox"/> Release 98 <input checked="" type="checkbox"/> Release 99 <input checked="" type="checkbox"/> Release 00 <input type="checkbox"/>
------------------	--	-----------------	---

(only one category Shall be marked With an X)

Reason for change:

- Mono mode delivery of bearer is now obsolete per TC Sec LI latest interface
- Optimal routing is addressed as a topic in the specification.

Clauses affected: 6, 6.1.1,6.4.2,Annex A

Other specs Affected:	Other 3G core specifications <input type="checkbox"/> Other GSM core specifications <input type="checkbox"/> MS test specifications <input type="checkbox"/> BSS test specifications <input type="checkbox"/> O&M specifications <input type="checkbox"/>	→ List of CRs: → List of CRs: → List of CRs: → List of CRs: → List of CRs:	<input style="width: 100%; height: 100%;" type="text"/>
------------------------------	---	--	---

Other comments:

6 Invocation of Lawful Interception

The following picture shows the extract from the reference configuration which is relevant for the invocation of the lawful interception.

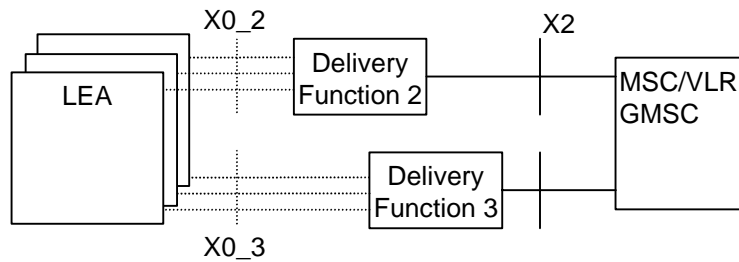

Figure 11: Functional model for Lawful Interception invocation

The X0_2 and X0_3-interfaces represent the interfaces between the LEA and two delivery functions. Both interfaces are subject to national requirements. They are included for completeness, but are beyond the scope of standardization. The delivery functions are used:

- to convert the information on the X2-interface to the corresponding information on the X0_2-interface;
- to distribute the intercept related information to the relevant LEA(s) (based on IAs, if defined);
- to distribute the intercept product to the relevant LEA(s) (based on IAs, if defined).

In case a call is selected based on several identities (MSISDN, IMSI, IMEI) of the same target, the MSC/VLR or GMSC will deliver IP and IRI only once to the DF2 and DF3. DF2 and DF3 will then distribute the information to the relevant LEA that requested interception on a particular target identity.

For the delivery of the IP and IRI the MSC/VLR or GMSC provides correlation number and target identity to the DF2 and DF3 which is used there in order to select the different LEAs where the product shall be delivered to.

NOTE: If interception has been activated for both parties of the call both IP and IRI will be delivered for each party as separate intercept activity.

The location dependency check occurs at the establishment of each call. Subsequent dependency checks for simultaneous calls are not required, but can be a national option.

If a target is marked using an IA in the MSC/VLR, the MSC/VLR shall perform a location dependency check at call set-up. Only if the target's location matches the IA the call is intercepted.

If a target is marked using an IA in the DF2, the DF2 shall perform a location dependency check at reception of the first IRI for the call. Only if the target's location matches the IA for certain LEAs the IRI is relayed to these LEAs. All subsequent IRIs for the call are sent to the same LEAs.

If a target is marked using an IA in the DF3, the DF3 shall perform a location dependency check at reception of the IP. Only if the target's location matches the IA for certain LEAs the IP is relayed to these LEAs.

Gateway intercept is not possible when optimal routing is employed.

6.1.1 — One stubline configuration (speech calls only) to LEA

~~Figures 14 and 15 show the configuration for a circuit switched speech call (not call hold / call waiting / multiparty). The signals of both ends of the connection are added and delivered to the requesting function. The signals from the requesting function have no impact on the connection which must be tapped.~~

~~The MSC/VLR or GMSC establishes the call and in parallel one (see figure 14) or two (see figure 15) stubline towards the DF3. Therefore it uses the address which has been provided as part of the activation.~~

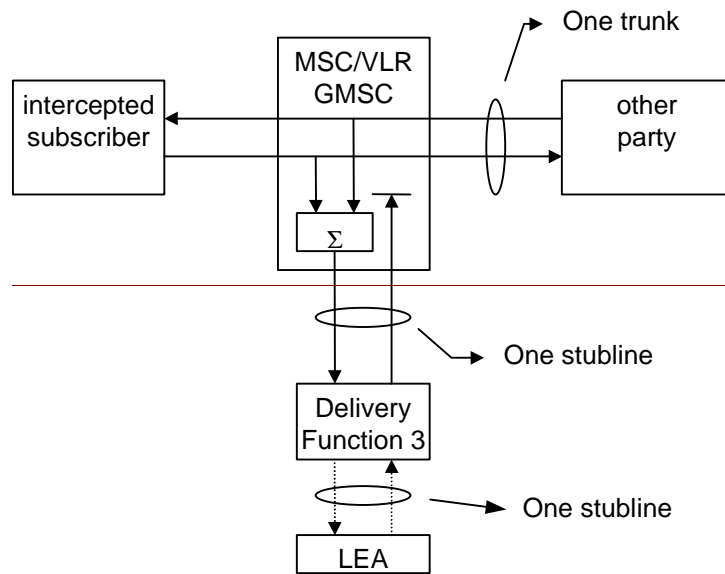

Figure 14: One stubline configuration to DF3 for the interception of a circuit switched call

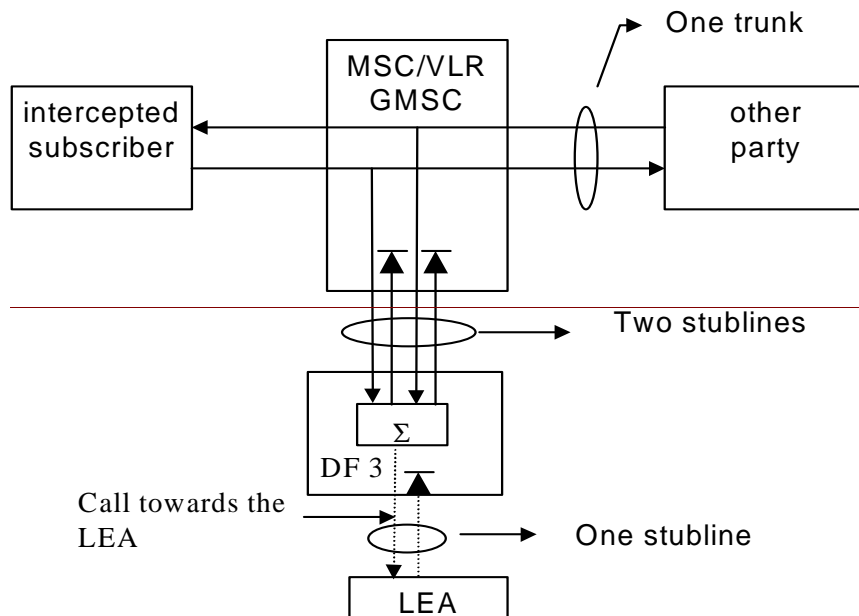

Figure 15: A two stubline configuration to DF3 for the interception of a circuit switched speech call

6.4.2 Interception for Call Forwarding / Call Deflection

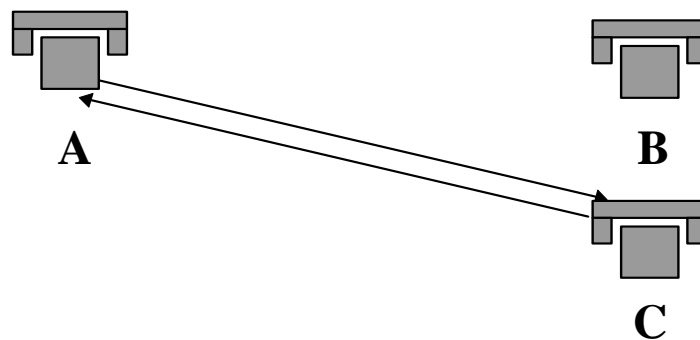

Figure 21: Interception for Call Forwarding / Deflection

For delivery of the Intercept Product it doesn't matter which of the three is monitored.

For Intercept Related Information it depends who is monitored:

- If subscriber A is monitored the number of A and B are mandatory in the event information and the number of C if available.
- If subscriber B is monitored the number of B and C are mandatory in the event information and the number of A if available.
- If subscriber C is monitored the number of C is mandatory in the event information and the number of A if available.

When optimal routing is employed, interception of call forwarding by party B may not be available.

Annex A (normative): Information flows for Lawful Interception invocation

The following figures show the information flows for the invocation of Lawful Interception for various types of calls. The figures show some of the basic signalling messages of the target calls and the events on the X2 and X3-interfaces. The ISUP messages to and from the network are shown for informational purposes only; some of them may not be sent or may be combined in certain networks.

~~For information flows involving multiple calls, both the case where one stubline or pair of stublines is used per target, and the case where a separate stubline or pair of stublines is used for each target call is shown.~~

A.1 Mobile originated circuit switched calls

Figure A1 shows the interception of a basic mobile originated circuit switched speech or data call where the originating mobile (A) is the target for interception. B is not necessarily also a mobile subscriber and resides on a different exchange.

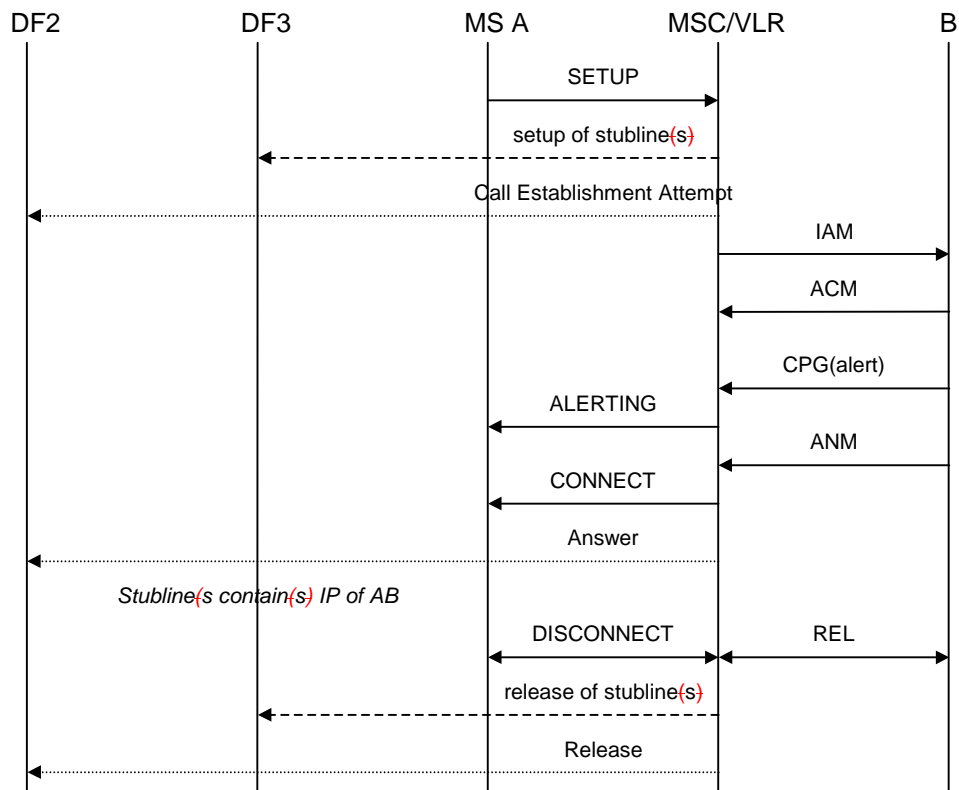

Figure A1: Interception of mobile originated circuit switched calls

| In figure A1 the result (answer) of the set-up of the stubline(s) is not shown. This assumes no special action is taken in case of failure.

A.2 Mobile terminated circuit switched calls

Figure A2 shows the interception of a basic mobile terminated circuit switched speech or data call where the terminating mobile (B) is the target for interception. A is not necessarily also a mobile subscriber and resides on a different exchange.

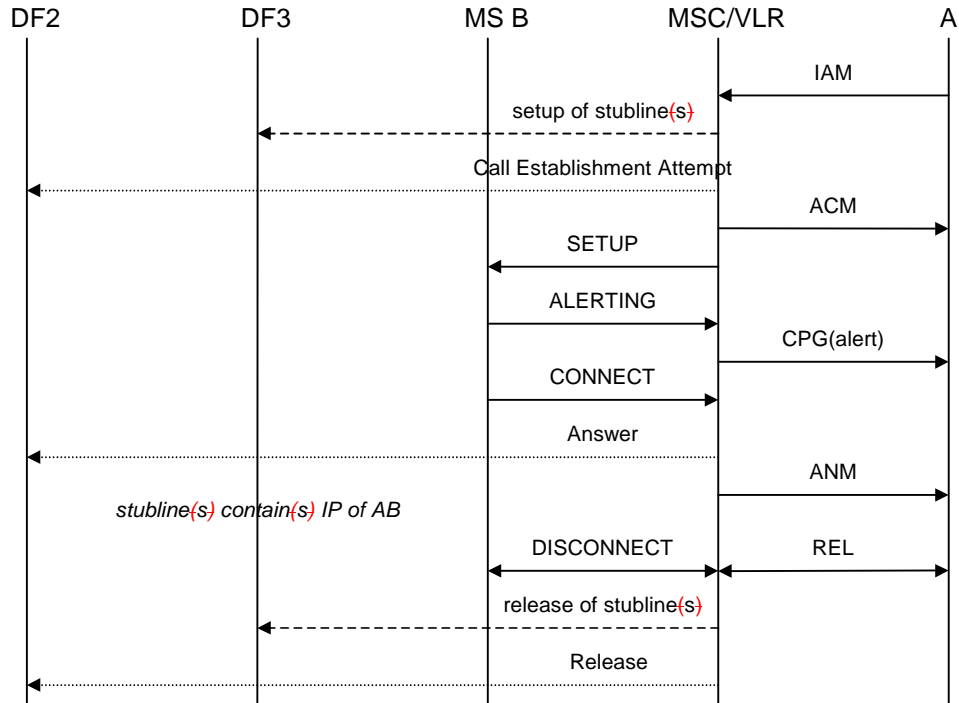

Figure A2: Interception of mobile terminated circuit switched calls

A.3 Call hold / call waiting

Figures A3 and A4 show the interception of calls involving call hold / call waiting. Figure A3 covers the case where ~~one stubline or~~ one pair of stublines is used per target, figure A4 covers the case where ~~a separate stubline or~~ pair of stublines is used for each target call. The mobile that receives the waiting call (A) is the target for interception.

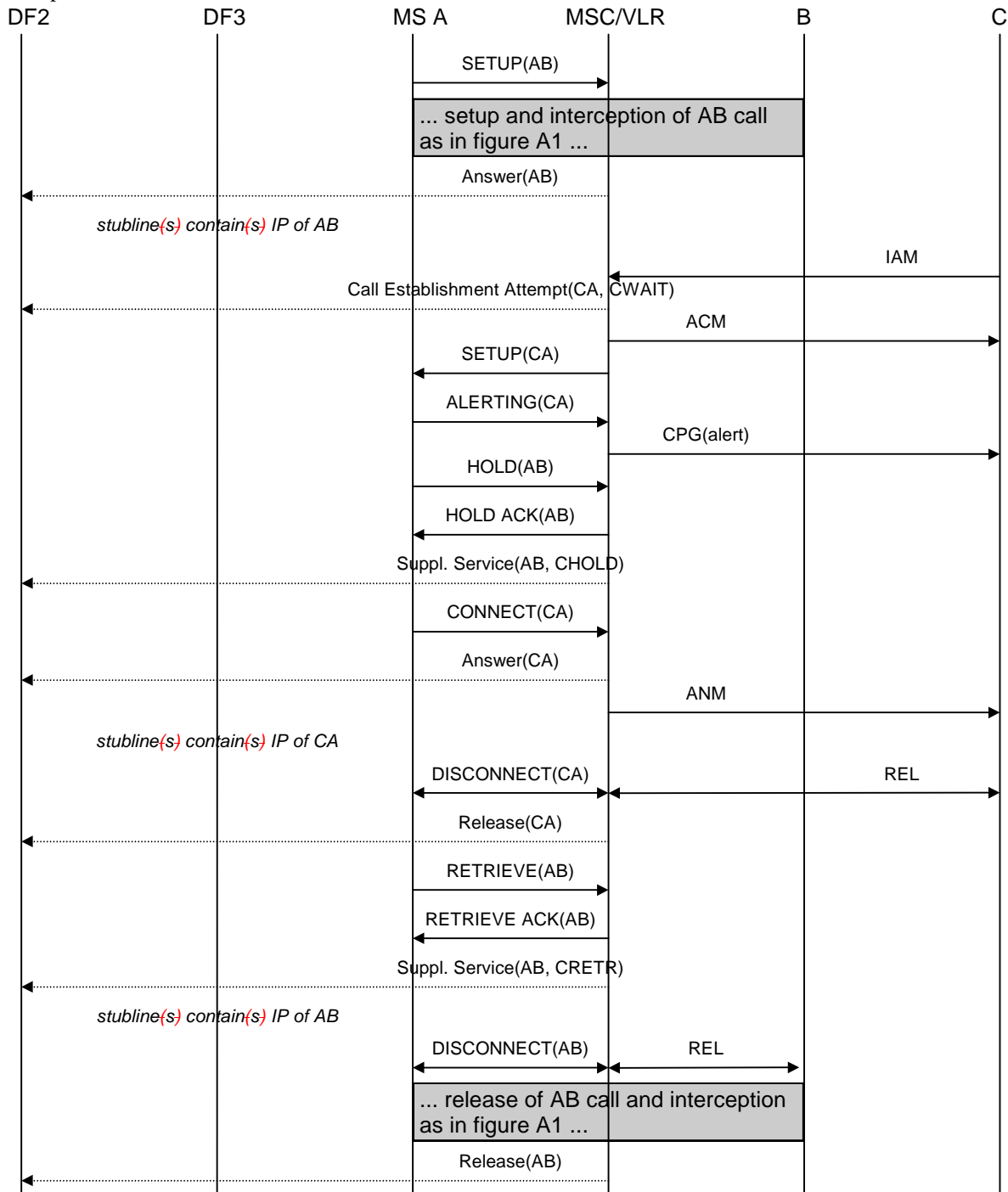

Figure A3: Interception of call hold / call waiting - stubline(s) per target

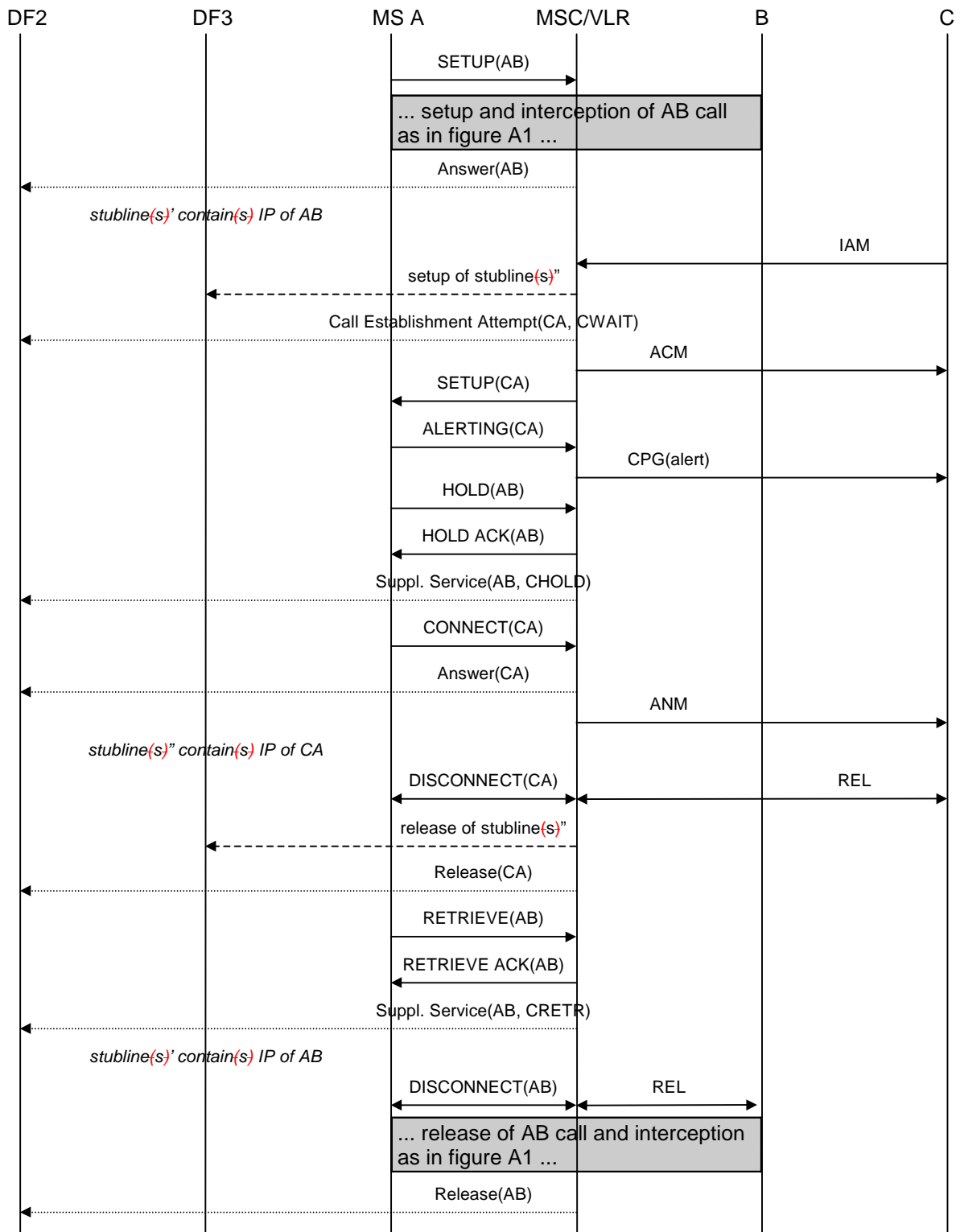

Figure A4: Interception of call hold / call waiting - stubline(s) per target call

A.4 Multiparty calls

Figures A5 and A6 show the interception of multiparty calls. Figure A5 covers the case where ~~one stubline or~~ one pair of stublines is used per target, figure A6 covers the case where ~~a separate stubline or~~ a separate stubline or pair of stublines is used for each target call. The mobile setting up the multiparty call (A) is the target for interception.

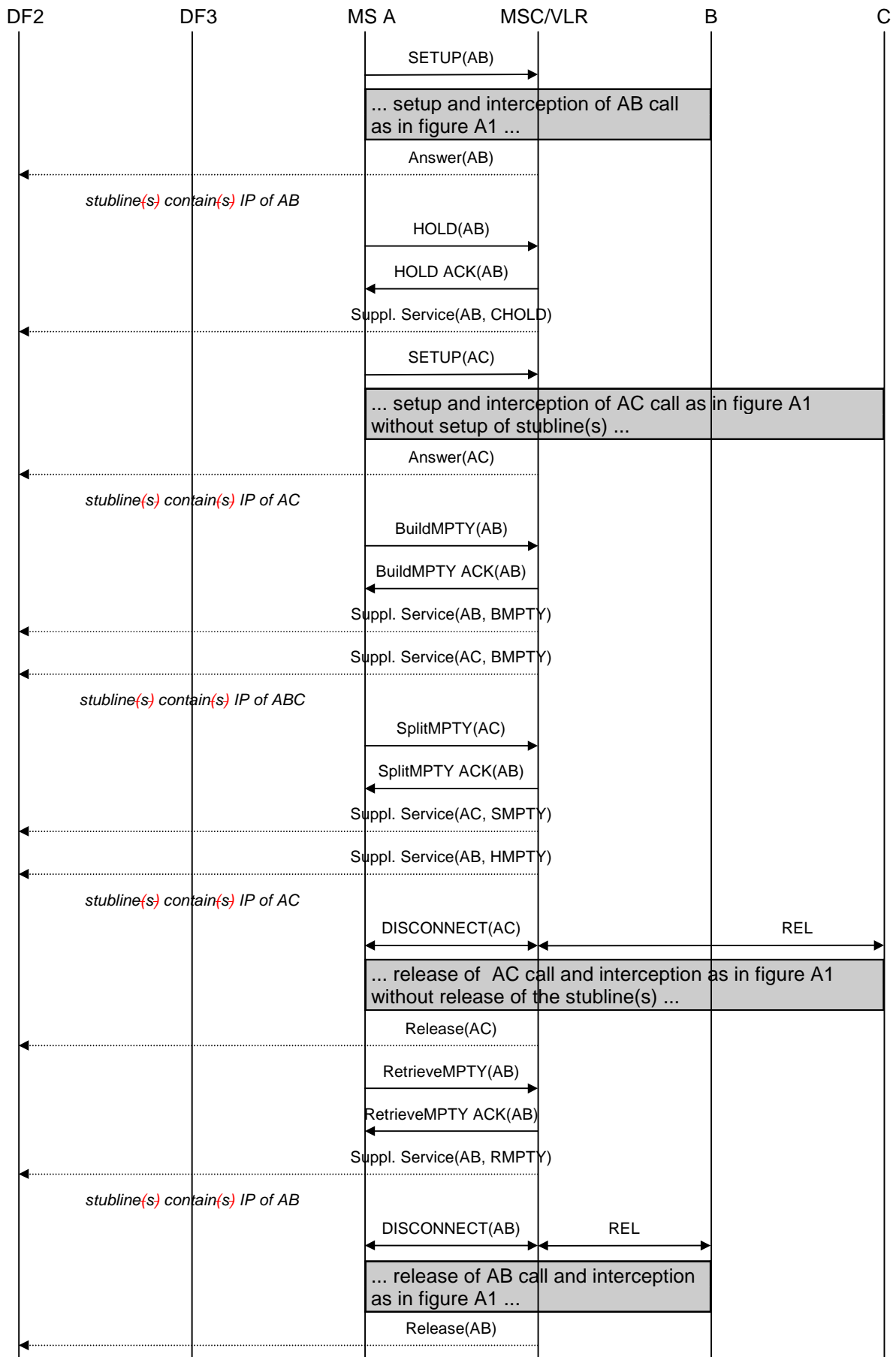

Figure A5: Interception of multiparty calls - stubline(s) per target

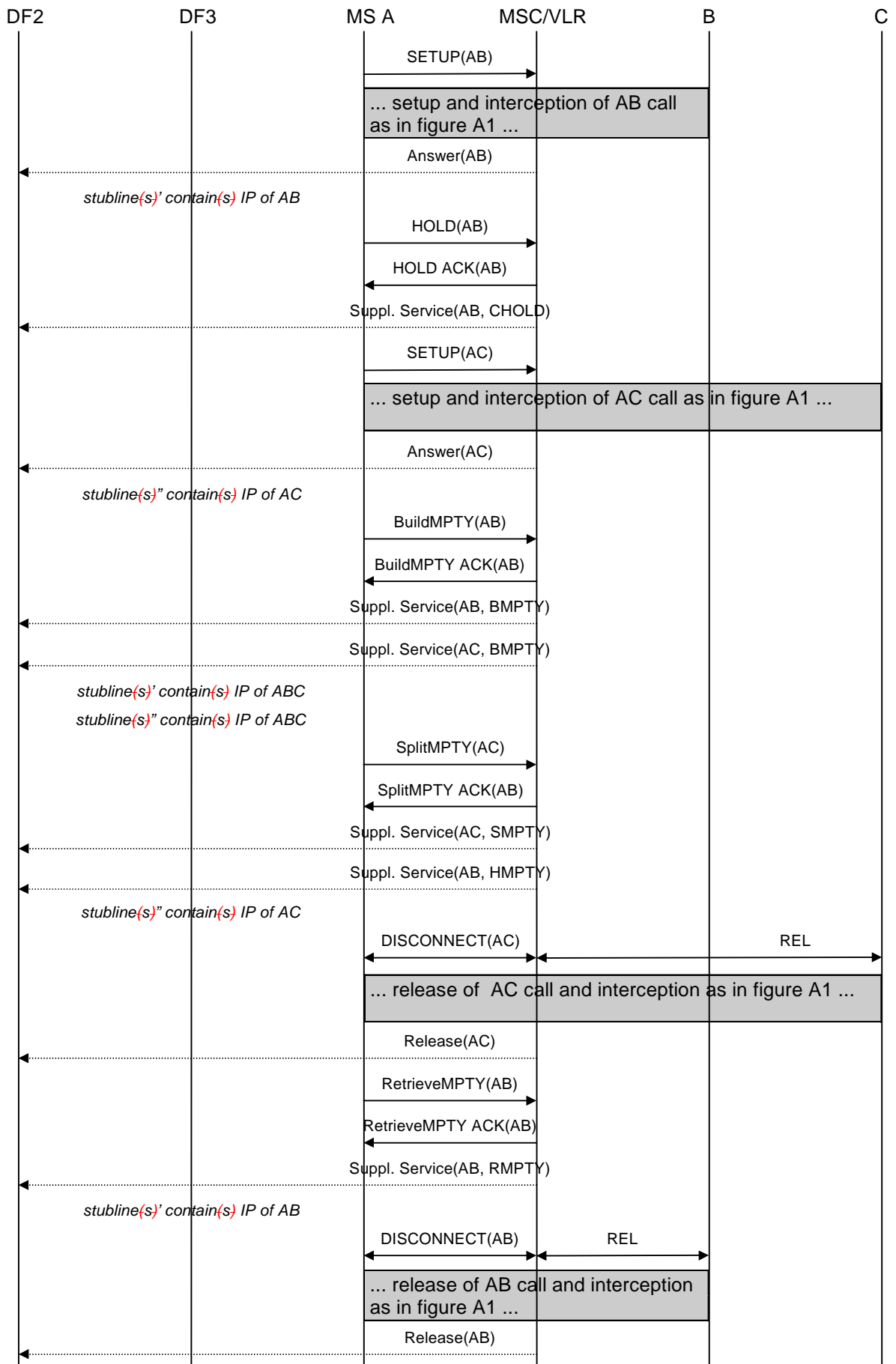

Figure A6: Interception of multiparty calls - stubline(s) per target call

A.5 Call forwarding / call deflection

The following pictures show the information flows for the interception of forwarded calls. Information flows will be given for three typical cases of call forwarding. All other types of call forwarding / call deflection are intercepted similar to one of these.

A.5.1 Unconditional call forwarding

Figure A7 shows the interception of unconditionally forwarded calls. The mobile that activated unconditional call forwarding (B) is the target for interception. In this case interception will be performed at the GMSC, where the SRI request for B is issued and subsequently the SRI response indicating that the call must be forwarded is received back.

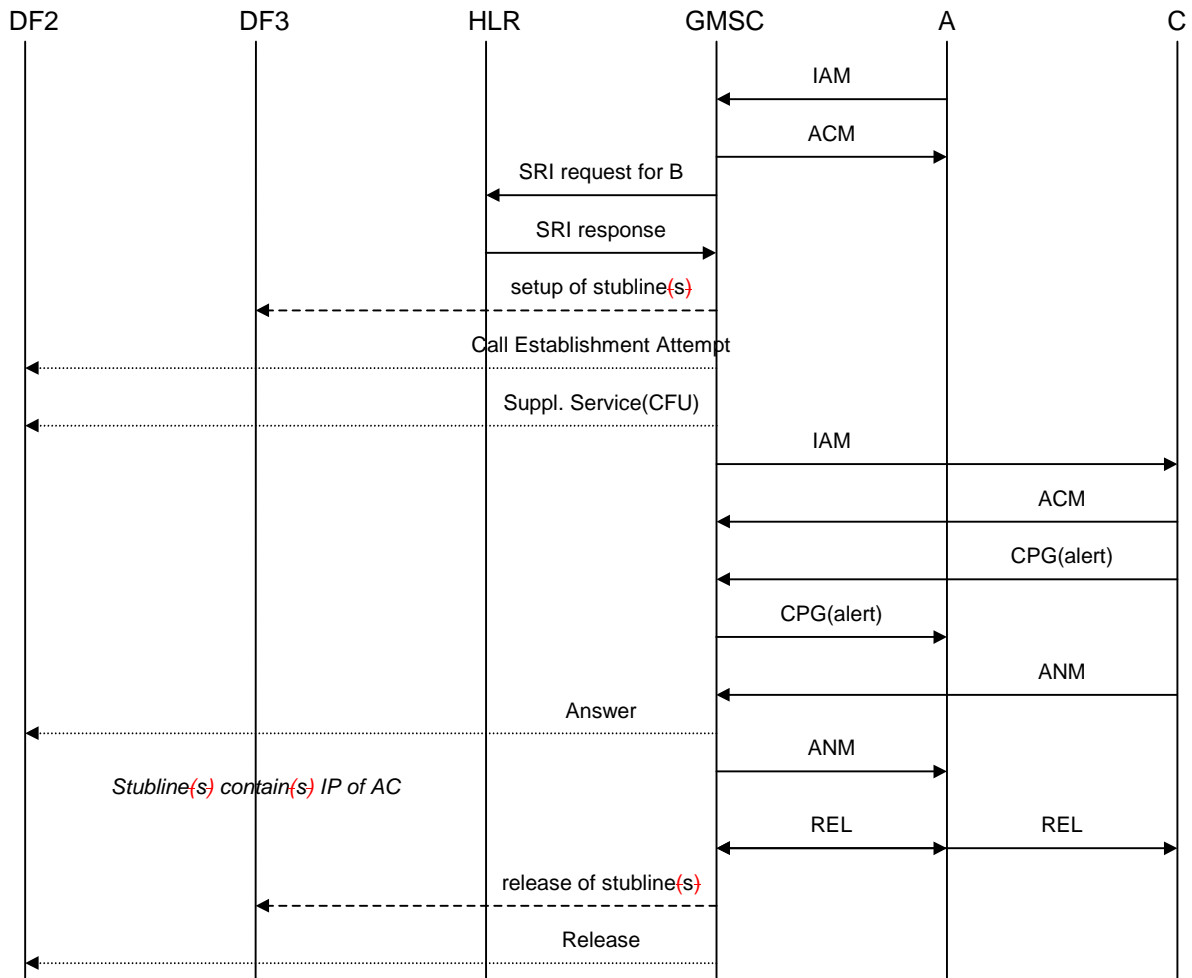

Figure A7: Interception of unconditional call forwarding

A.5.2 Call forwarding on not reachable (IMSI detached)

Call forwarding on not reachable because the IMSI is detached is also handled on the GMSC. Interception of this type of call forwarding is similar to interception of unconditional call forwarding.

A.5.3 Call forwarding on busy (network determined)

Figure A8 shows the interception of call forwarding on busy (network determined). The mobile that activated call forwarding on busy (B) is the target for interception. In this case interception will be performed at the MSC/VLR where B resides, where the busy condition is detected and the call is forwarded.

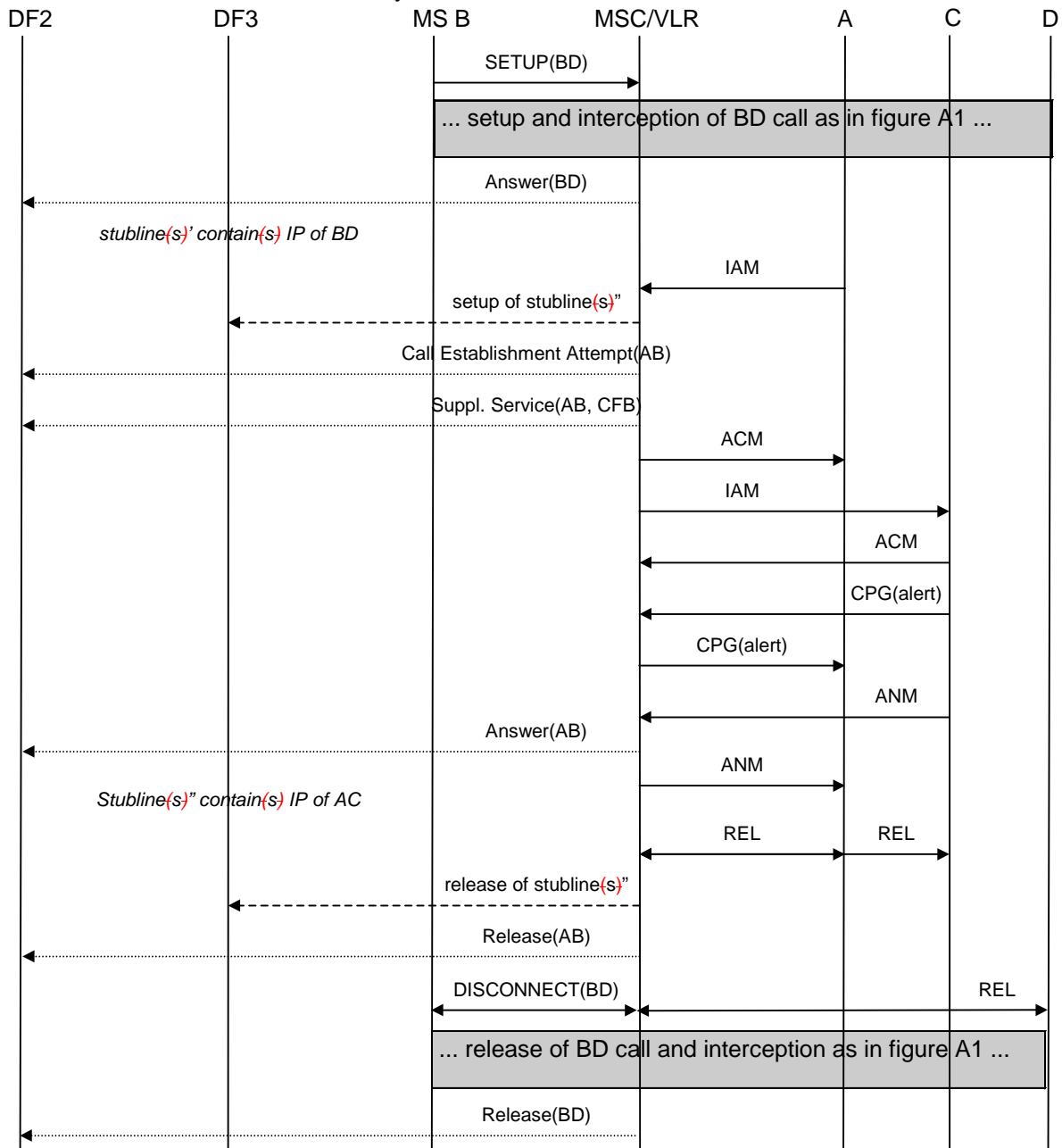

Figure A8: Interception of call forwarding on busy (network determined)

A.5.4 Call forwarding on not reachable (no response to paging/radio channel failure)

Call forwarding on not reachable because of no response to paging or radio channel failure is also handled on the MSC/VLR similar to call forwarding on busy (network determined). Interception of this type of call forwarding is therefore done in the same way.

A.5.5 Call forwarding on no reply

Figure A9 shows the interception of call forwarding on no reply. The mobile that activated call forwarding on no reply (B) is the target for interception. In this case interception will be performed at the MSC/VLR where B resides, where the no reply condition is detected and the call is forwarded. Initially, the interception is similar to the interception of a basic mobile terminated circuit switched speech of data call. On no reply time-out, the interception will continue on the forwarded call to C.

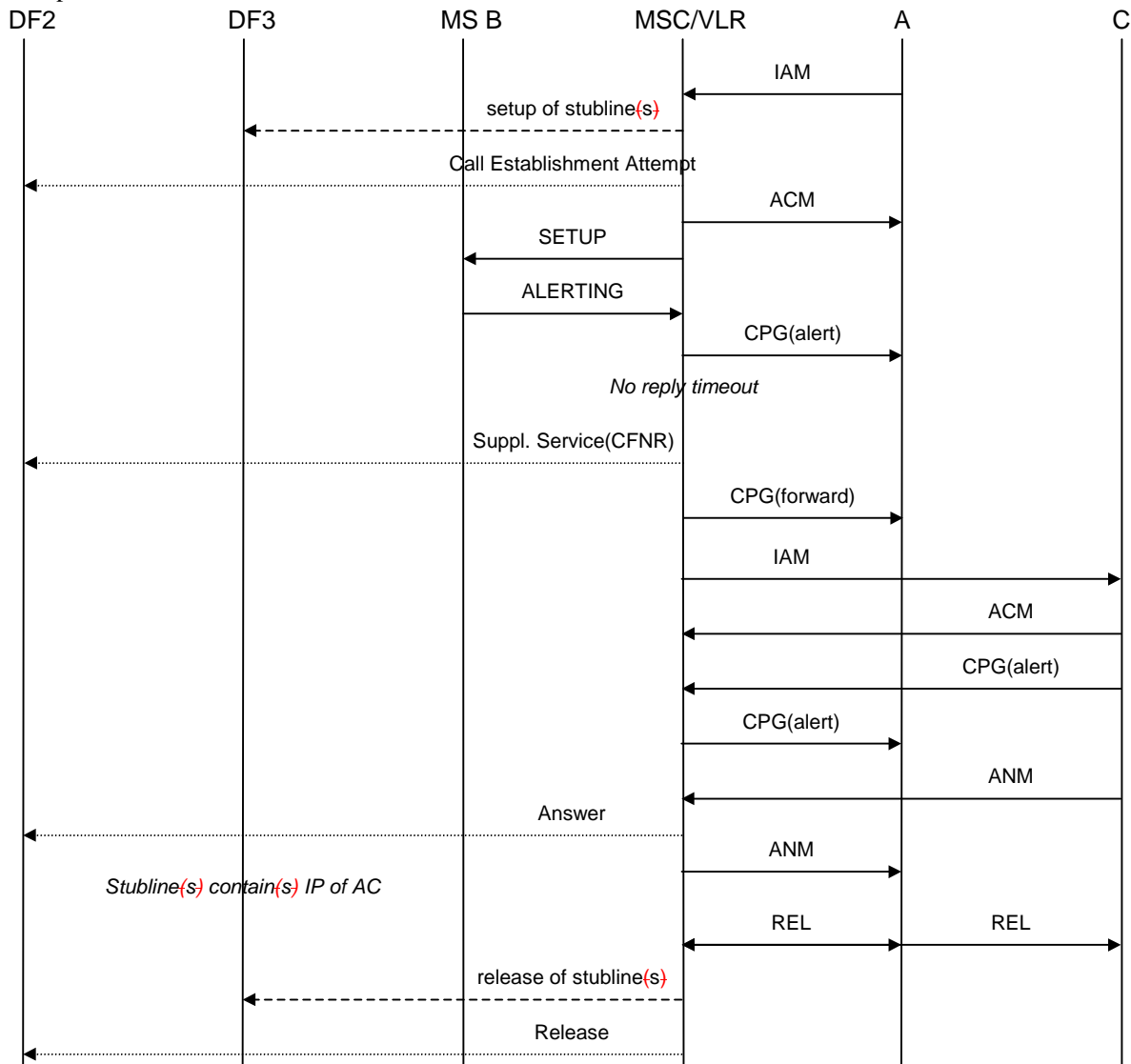

Figure A9: Interception of call forwarding on no reply

In figure A9 the release of the stubline(s) is done after the forwarded call is released by A or C. It is a national option not to support interception of forwarded calls. In that case, the release of the stubline(s) is done after the call is forwarded and B is no longer involved.

A.5.6 Call forwarding on busy (user determined)/call deflection

Call forwarding on busy (user determined) and call deflection are also handled on the MSC/VLR similar to call forwarding on no reply. Interception of this type of call forwarding is therefore done in the same way.

A.5.7 Call waiting / call forwarding on no reply

Figures A10 and A11 show the interception of a call involving both call waiting and call forwarding on no reply. Figure A10 covers the case where ~~one stubline or~~ one pair of stublines is used per target, figure A11 covers the case where ~~a separate stubline or~~ pair of stublines is used for each target call. The mobile that activated call forwarding on no reply and receives the waiting call (B) is the target for interception. In figure A10 a new (pair of) stubline(s) needs to be set up when the call is forwarded since the first (pair of) stubline(s) is still used for the initial call.

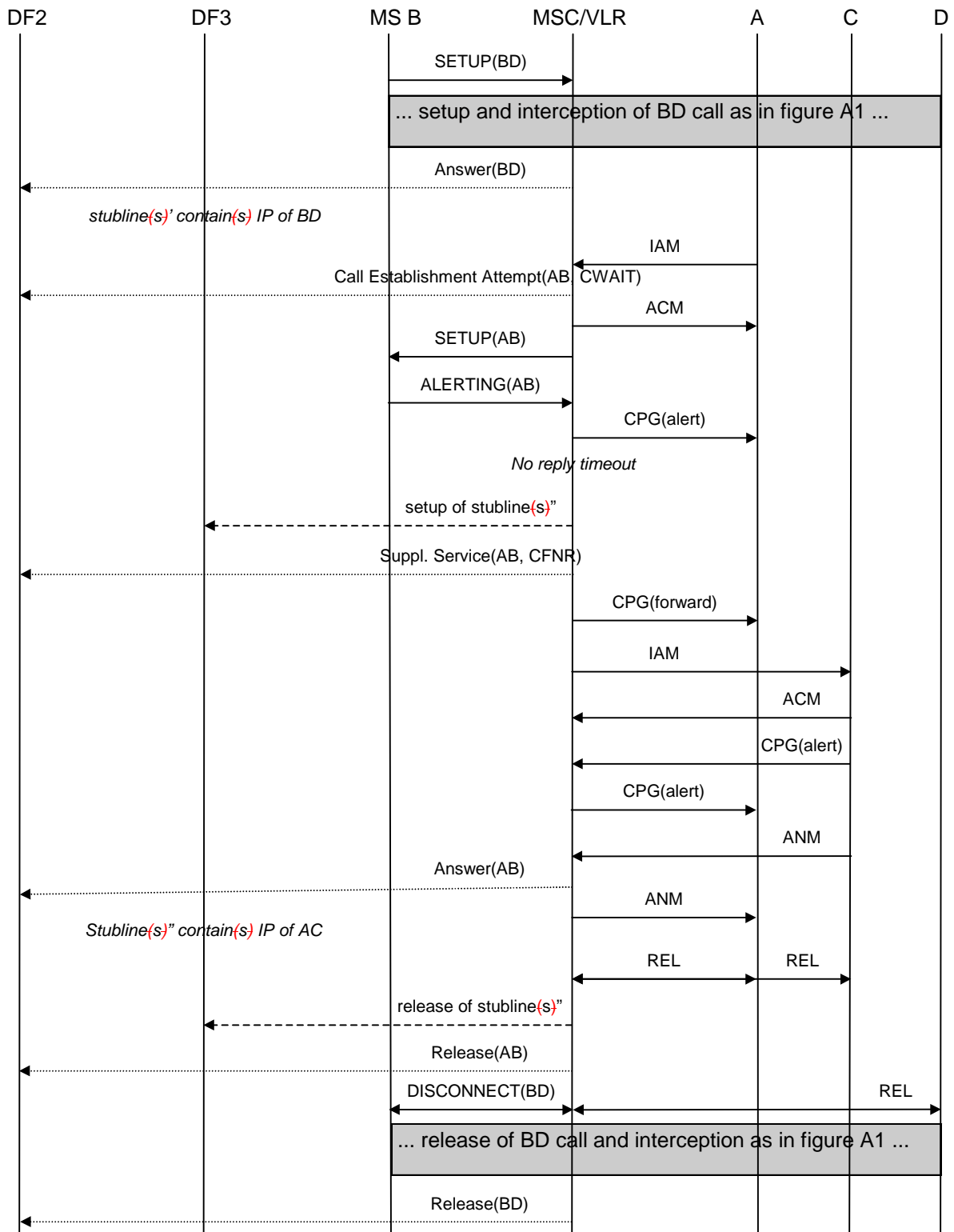

Figure A10: Interception of call waiting / call forwarding on no reply - stubline(s) per target

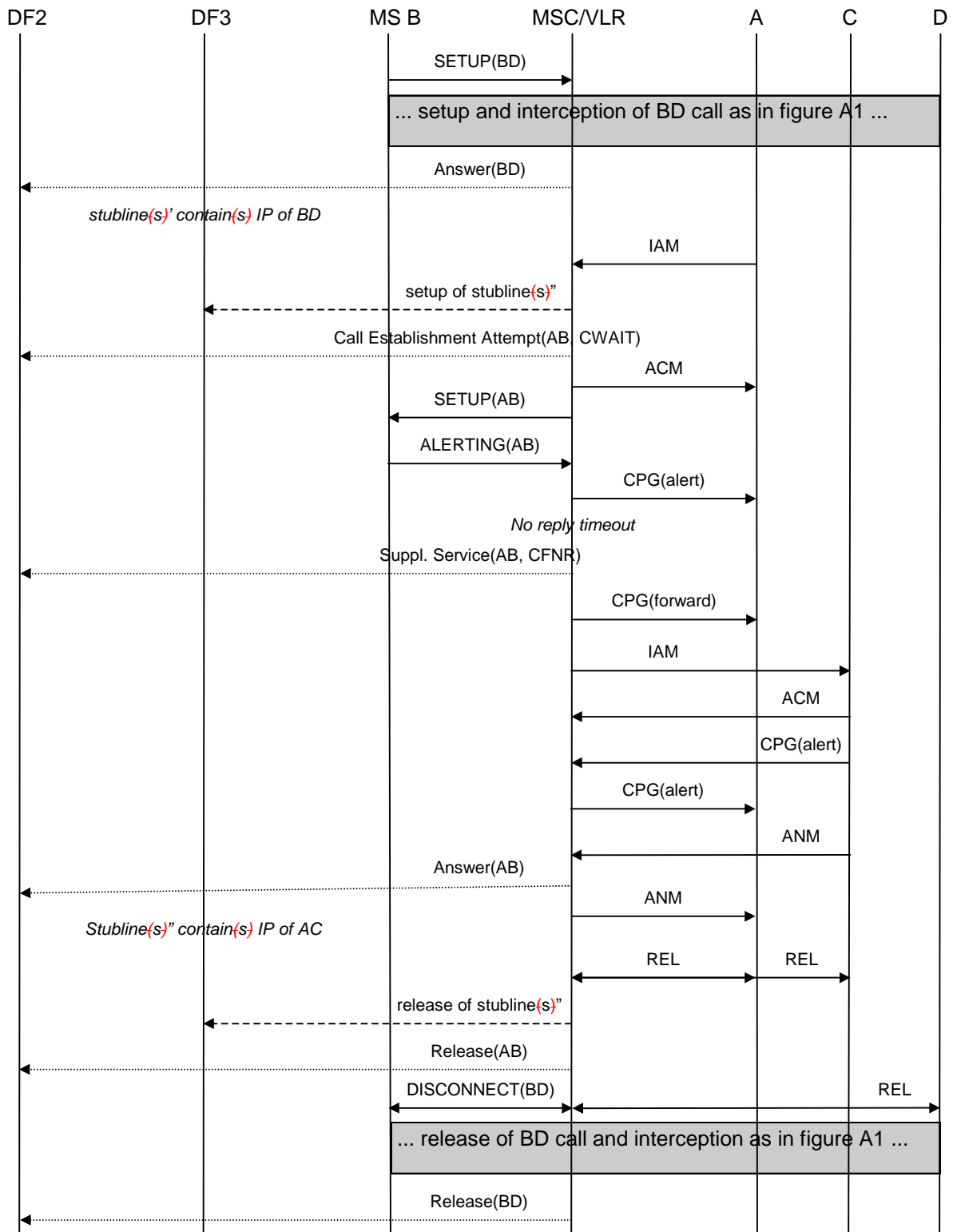

Figure A11: Interception of call waiting / call forwarding on no reply - stubline(s) per target call

A.6 Explicit call transfer

Figures A12 and A13 show the interception of explicit call transfer. Figure A12 covers the case ~~where one stubline or~~ one pair of stublines is used per target, figure A13 covers the case where a ~~separate stubline or~~ pair of stublines is used for each target call. The mobile transferring the call (B) is the target for interception.

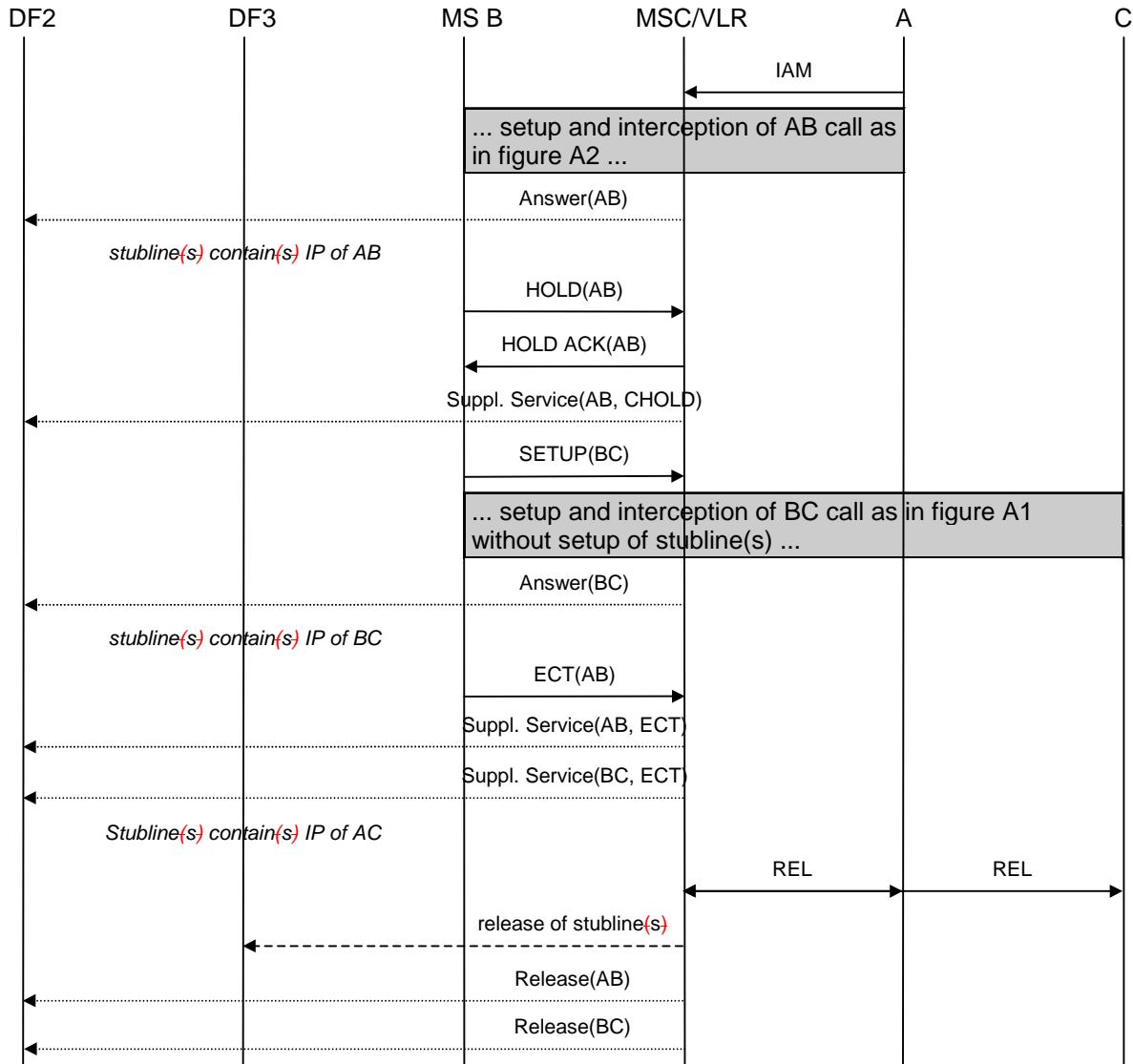

Figure A12: Interception of explicit call transfer - stubline(s) per target

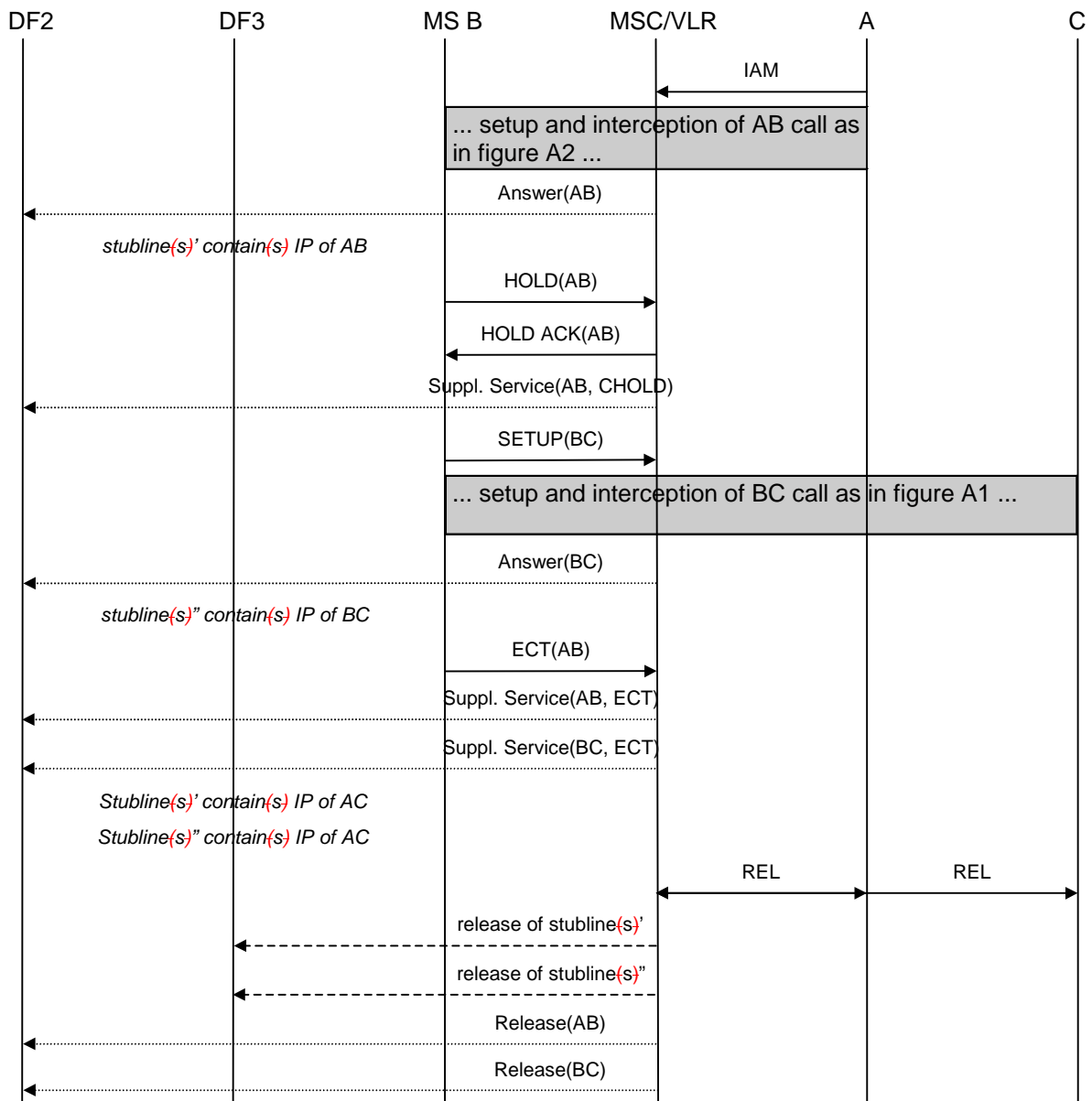

Figure A13: Interception of explicit call transfer - stubline(s) per target call

In figures A12 and A13 the release of the stubline(s) is done after the transferred call is released by A or C. It is a national option not to support interception of transferred calls. In that case, the release of the stubline(s) is done after the call is transferred and B is no longer involved.