

**UMTS Baseline document;
Positions on UMTS agreed by SMG including
SMG#26
(Draft UMTS 30.01 version 3.5.1 - Approved by E-mail after
SMG#27)**

UMTS

Universal Mobile
Telecommunications System



European Telecommunications Standards Institute

Reference

DTR/SMG-003001U

Keywords

Universal Mobile Telecommunications System (UMTS),
Global Multimedia Mobility (GMM), Third Generation
Global System for Mobile Communications

ETSI Secretariat

Postal address

F-06921 Sophia Antipolis Cedex - FRANCE

Office address

650 Route des Lucioles - Sophia Antipolis
Valbonne - FRANCE
Tel.: +33 4 92 94 42 00 Fax: +33 4 93 65 47 16
Siret N° 348 623 562 00017 - NAF 742 C
Association à but non lucratif enregistrée à la
Sous-Préfecture de Grasse (06) N° 7803/88

X.400

c= fr; a=atlas; p=etsi; s=secretariat

Internet

secretariat@etsi.fr
<http://www.etsi.org>

Copyright Notification

No part may be reproduced except as authorized by written permission.
The copyright and the foregoing restriction extend to reproduction in all media.

© European Telecommunications Standards Institute 1999.
All rights reserved.

Contents

1	Scope	5
2	Key requirements to UMTS	5
3	Phased concept of UMTS	6
4	Key features of UMTS	6
4.1	Key content of UMTS Phase 1	8
4.2	SMG#26 on UMTS phase 1 scope	9
5	Principles of Evolution	9
6	Roaming between UMTS and other network systems.....	9
7	UMTS time schedule	9
8	Relationship between UMTS and other third generation mobile systems.....	11
8.1	Conclusions	11
8.1.1	IMT-2000 Family Concept.....	11
8.1.2	Role of ITU.....	11
8.1.3	Role of ETSI.....	11
8.1.4	Relation between IMT-2000 and UMTS	12
8.2	SMG policy on IMT-2000 Family Concept.....	12
9	Services.....	12
9.1	Service Aspects	12
9.2	Location Services	13
9.3	Charging aspects.....	13
10	UMTS radio access	13
10.1	Basic requirements to the UMTS radio access	13
10.1.1	High level requirements relevant for the definition of the UMTS Terrestrial Radio Access UTRA concept	14
10.1.2	Support of speech by the UMTS access system.....	14
10.1.2.1	AMR.....	14
10.1.3	Essential requirements toward UMTS for private and business applications.....	15
10.2	Procedure for the definition of the UMTS Terrestrial Radio Access	15
10.3	Time schedule for UMTS Terrestrial Radio Access definition	15
10.3.1	Milestone M1	16
10.3.2	Milestone M2	16
10.3.3	Milestone M3	17
10.3.4	Milestone 4.....	17
10.4	Principles for hardware validations during the definition of the UMTS Terrestrial Radio Access (UTRA)..	17
10.5	Dual mode operation GSM/UMTS and handover	18
10.6	Selection procedures for the choice of radio transmission technologies of the UMTS.....	18
10.7	Establishment of SMG's "Evaluation group of the IMT-2000 RTT's Radio Transmission Technologies"....	18
10.8	Harmonisation of UTRA with other Radio Access Schemes	18
10.9	Report on Essential IPRs	19
11	Network aspects	19
12	UMTS satellite component.....	19
12.1	S-PCN - UMTS interference	20
13	Operation and maintenance.....	20
14	Other aspects.....	21
14.1	Emergency call	21
14.2	Global pilot channel.....	21
14.3	Regulatory issues	21
14.4	USIM (UMTS SIM) Card.....	21

15	Relationship to other bodies	22
15.1	Relationship to ITU.....	22
15.1.1	Relationship to ITU-T.....	22
15.1.1.1	Relationship to ITU SG11	22
15.1.2	Relationship to ITU-R TG8/1.....	22
15.2	Relationship to Japan ARIB/TTC.....	22
15.3	Relationship with GMM CG	23
15.4	Relationship to UMTS Forum	23
15.5	Relationship to GSM MoU 3GIG	23
15.6	Relationship to ACTS	23
15.7	Relationship to ATM Forum	23
15.8	Relation to China MPT/RITT.....	23
15.9	Relation to UGG UMTS Globalization Group	23
16	Work planning and standardisation organisation.....	24
16.1	UMTS work programme within ETSI	24
16.2	SMG's UMTS Work programme	24
16.2.1	Document Structure of GSM and UMTS Release 99 Specifications.....	24
16.3	Organisation within SMG	25
16.3.1	STC's and other groups responsibilities	25
16.3.2	Proposal on the future organisation of GSM and UMTS standardisation	26
16.3.2.1	SMG26 on Globalisation	26
16.3.2.2	Extraordinary General Assembly meeting, 29 September 1998.....	28
16.4	MoU for Voluntary Funding	28
Annex 1:	(Editorial note: To be updated in order to reflect the current situation) Third Generation Standardisation Policy : Relation between IMT-2000 and UMTS	30
Annex 2:	Universal Mobile Telecommunications System; High level requirements relevant for the definition of the UMTS Terrestrial Radio Access (UTRA) concept.....	33
Annex 3:	Support of speech by the UMTS access system.....	37
Annex 4:	UMTS Radio Access Scheme Selection Criteria.....	39
Annex 5:	Procedure for the definition of the UMTS Terrestrial Radio Access	40
Annex 6:	Proposed Time schedule for UMTS Terrestrial Radio Access definition.....	42
Annex 7:	Liaison statement on principles for hardware validations during the definition of the UMTS Terrestrial Radio Access (UTRA)	44
Annex 9:	Consideration of a Global pilot mechanism	45
Annex 10:	Agreement on Common Working Procedures between ARIB and SMG.....	47
Annex 11:	Agreed proceeding for the SMG - TTC network aspects working group:.....	48
Annex 12:	Future Organisation for GSM and UMTS Standardisation.....	49
Annex 13:	SMG policy on IMT-2000 Family Concept	52
History.....		54

1 Scope

This position paper defines the agreed positions for the ETSI third generation global system for mobile communications, known as UMTS, Universal Mobile Telecommunications System.

The baselines include

- key features of UMTS;
- milestones and time plan for the development of UMTS in a phased approach;
- the principles for evolution from second generation mobile communications systems, in particular GSM and ISDN.

The document is focused on standardisation rather than research.¹

This document is under direct responsibility of SMG; there is no prime responsible subgroup of SMG responsible for it. It is managed and edited by PT SMG and directly approved by SMG. It reflects fundamental decisions of SMG and will hence be typically updated after each SMG plenary in the initial phase of UMTS. For approval at SMG, a version with revision marks to the last approved version and a clean version are presented.

2 Key requirements to UMTS²

An intensive discussion in the UMTS Task Force and Forum and within ETSI reviewed the vision of UMTS and came to the following conclusions:

- UMTS must be a true third generation service and system
- UMTS will have an evolution path from GSM, ISDN and from DECT as an access infrastructure.
- UMTS is based on the GMM architecture framework.
- A UMTS BSS will be developed as a generic radio access.
- Core networks supporting UMTS are market driven evolutions of GSM and ISDN (including CTM).
- UMTS is part of the system family developed by ETSI for the world market. An open world-wide participation in this process is encouraged.
- UMTS is a basis for the European Third Generation Plan spectrum plan.

¹ SMG#20 meeting report

² SMG#21 meeting report, 7.6.2, Tdoc SMG 293/97

3 Phased concept of UMTS³

UMTS will be developed in phases. This development in phases and the modular approach of UMTS will allow the introduction of new capabilities and evolution of capabilities according to market needs.

- Phase 0 is the pre-UMTS implementation of UMTS-like services in evolved GSM networks (using the evolved GSM radio access).
- UMTS phase 1 shall use the UMTS radio access. Operation is planned for 2002.
- After year 2002 UMTS will evolve in annual phases.
- Services should be separated from the technology platform, independent from the radio access technology and independent from the core network.
- UMTS should have a modular approach. New capabilities and evolution of capabilities should be standardised in a phased approach according to market needs

4 Key features of UMTS

- **Wideband and multimedia services:** It is essential that UMTS supports the full range of applications from narrowband (most important: speech) to wideband (2Mbps as target) based upon an advanced high efficient and flexible radio access scheme.
- For multimedia services, high bit rates and a high degree of flexibility are indispensable (e.g. negotiable or variable bit rate is essential for end users).
- Some operators, due to limited access to frequencies, will need to offer speech in UMTS. To plan UMTS to offer multimedia wideband services only (i.e. without narrowband speech) would not be economically viable.⁴
- **High quality speech:** work on a new codec must be elaborated and clarified.
- **Spectrum efficiency** is an important aim for the UMTS radio access⁵ For all envisaged services. For speech, the efficiency should be at least as good as GSM. For other services, wideband spectrum efficiency should be considered e.g high importance.
- UMTS is a third generation system and must make a sufficient technology step to differentiate it from second generation systems, and will have to co-exist with GSM. UMTS is not an “extended GSM” and the future should not necessarily be compromised for the sake of evolution from GSM.
- UMTS is a wireless mobile system. Mobility must include personal and terminal and service mobility to permit roaming and “Service Mobility” for the user to take his services with him.
- UMTS will allow for **service creation**, unlike second generation systems which defined exact services, hindering differentiation and competition. Service creation utilising the latest IT techniques should allow the creation of innovative services and individualised service profiles and the ability to download them to subscribers.
- **Evolution** within the standard is essential to allow innovation in service and technology.

³ SMG#20 meeting report, 7.6.2

⁴ SMG#20 meeting report, 7.6.3, based on Tdoc 727/96

⁵ SMG#20 meeting report, 7.6.1, based on Tdoc SMG 647/96

- The standardisation of UMTS shall allow each operator to select its own evolution path towards UMTS, considering its nature (e.g. mobile or fixed network operator), its own strategies, the regulatory environment and his level of development in telecommunications of its country.
- **Convergence and Integration** are a major theme. The standard must provide an integrated approach to wireless services, eg: WLL, cordless, cellular and satellite service access. Telecoms and IT convergence offer mobile access to the “information society”.
- The ability to support secure Global Cross-standard Roaming should be provided. Security and fraud control must be controlled from the home network wherever you are through the integration and development of MAP, IS41 and INAP signalling protocols.
- UMTS should support “**Global Multi-Media Mobility**” (GMM) Information Society services. Services can be added during a call. Billing must reflect usage and be understandable to the user.
- **Intelligence** is likely to be distributed through the network for efficient support of information based services.
- **Virtual Home Environment** describes a service that moves with you, so that the user interfaces with the service rather than the terminal, feeling at home when roaming, with familiar service offerings and MMI]

4.1 Key content of UMTS Phase 1⁶

Key content of UMTS Phase 1

	UMTS Phase 1 standard (operation 2002 possible)
Services	<ul style="list-style-type: none"> - multimedia services phase 1: <ul style="list-style-type: none"> - at least 2 Mbit/s with maximal speed of 10 km/h - at least 384kbit/s in suburban outdoor with maximal speed of 120 km/h - at least 144 kbit/s in rural with maximal speed of 500 km/h - high quality speech (like fixed networks) using low bitrates - packet and circuit switched services for the different bit rates and the different radio environments - service creation and measurement toolkit - services portability, when roaming into other networks - advanced addressing mechanisms, e.g. personal, internet-style - charging mechanisms (e.g. volume) - dual band/mode of operation UMTS/GSM incl. roaming between UMTS „islands“ - roaming between UMTS and GSM networks - operate in any suitable band that becomes available, e.g. GSSM, DCS1800, PCS1900
Terminals	<ul style="list-style-type: none"> - mobiles and SIM with downloading capabilities over the air for e.g. data and applications (feasibility in phase 1 needs further study) - multi media terminals - dual mode/band GSM/UMTS terminals - adaptive terminals
Access network	<ul style="list-style-type: none"> - New UMTS BSS <ul style="list-style-type: none"> - flexible bearer - rates <= 2 Mbit/s - fast, self adapting interface - high capacity - support of variable bitrates and of mixed traffic types - high spectrum efficiency for multimedia and low bit rate speech
Core transport network	<ul style="list-style-type: none"> - evolution of the GSM NSS and ISDN/IN - new charging and accounting mechanisms - support of service mobility across networks - VHE - support of variable bitrates and of mixed traffic types - mobile fixed convergence elements - support of packet data by Internet protocols
Security	<ul style="list-style-type: none"> - protection of network use - provision of security services for the user - control of misuse of the network
Operation and Maintenance	<ul style="list-style-type: none"> - automatic establishment of roaming relations - support of multivendor networks

⁶ SMG#20 meeting report, based on Tdoc SMG 682/96 and ETR Security principles for the UMTS

4.2 SMG#26 on UMTS phase 1 scope⁷

The scope of UMTS phase 1 should be further elaborated by SMG1 and SMG12. SMG12 should intensify its work on network aspects and the review of WI descriptions for UMTS that is based on service and other requirements and the UMTS Baseline document; they should also continue to take into account ETSI GA decision on two developments paths for the UMTS Core Network, evolution from GSM and from ISDN.

5 Principles of Evolution

After UMTS Phase 1 there should be an evolution of UMTS in annual phases.

6 Roaming between UMTS and other network systems

Roaming is understood as the user's possibility to get service from one or more service providing networks based on a subscription with a home network. The service providing networks may belong to the same (intra-standard roaming) or other standards as the home network (inter-standard roaming).

Private networks:

The impact of private systems as well as various roaming approaches will be studied for the UMTS concepts.⁸

Temporary note: The area of residential/private systems needs more studies. It will be studied in the future TC SMG meetings. Contributions are needed.⁹

7 UMTS time schedule

Figure 7.1 UMTS 30.01 shows the next steps for the UMTS development. Table 7.1 UMTS 30.01 is the UMTS time table.

Figure 2.1/UMTS 30.00: Focus of the UMTS work for 1997/1998

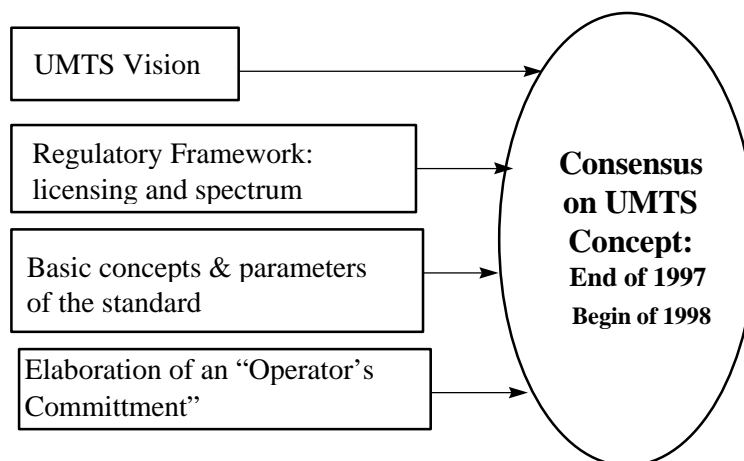

⁷ SMG#26 meeting report, chapter 7.4.3, page 62

⁸ SMG#21 meeting report, 7.6.1, based on Tdoc SMG 187/97

⁹ SMG#20 meeting report, 7.6.2, based on Tdoc SMG 682/96

Table 2.2/UMTS 30.00: Overall schedule for the UMTS Phase 1 development

Task Name	1996	1997	1998	1999	2000	2001	2002
GSM900 Phase 2+ implementation							
UMTS Vision							
Co-operative research: ACTS							
Regulation: framework (report UMTS Forum)							
Regulation: CEC, ECTRA, ERC decisions							
Regulation: national licence conditions							
Regulation: licence awards							
Operators' commitment: elaboration of draft							
Operators' commitment: signature							
ETSI: basic UMTS standards studies							
ETSI: freezing basic parameters of standard							
ETSI: UMTS Phase 1 standards							
Regulation: conformity assessment conditions							
Pre-operational trials							
UMTS Phase 1: commercial operation							

NOTE: Terminal type approval and certification need to be planned.

Notes on the UMTS time table:

The need to draw attention of non-European regulatory authorities to this schedule was noted. This activity is carried only the UMTS Forum and GSM MoU 3GIG¹⁰.

This schedule was also discussed in the UMTS Forum. and accepted in principle.

¹⁰ SMG#20 meeting report, 7.6.2, based on Tdoc SMG 682/96

8 Relationship between UMTS and other third generation mobile systems¹¹

NOTE: Relationship between UMTS and other third generation systems is given in Annex 01.

8.1 Conclusions

8.1.1 IMT-2000 Family Concept

Market needs and interests are different between the regions. It should therefore be recognised that there will be several different IMT-2000 systems based on a common frame work. All efforts should be made to enable roaming between these different IMT-2000 systems. These systems should be seen as a IMT-2000 family.

8.1.2 Role of ITU

ITU should focus on:

- recognition of the IMT-2000 family concept
- register IMT-2000 family members
- facilitate roaming between members of the IMT-2000 family
- service interworking between IMT-2000 systems
- framework standardisation
- seek commonalties between IMT-2000 systems
- free circulation issues
- spectrum issues.

8.1.3 Role of ETSI

ETSI should provide regularly focused information to ITU on GSM phase 2+ and UMTS.

ETSI work should focus on:

- intensify 3rd generation work
- standardisation of UMTS
- concentrate contributions to ITU on framework standardisation, service interworking and roaming between members of the IMT-2000 family
- submit a terrestrial radio access system candidate, which meets or exceeds essential ITU requirements as a member of the IMT-2000 family.

¹¹SMG#21,, 7.6.2, approved Tdoc SMG 293/97

8.1.4 Relation between IMT-2000 and UMTS

Although ETSI standards have a good international track record, many countries are bound to follow ITU recommendations. So to ensure world market access for UMTS there is a need for an ITU IMT-2000 label also on UMTS in some appropriate ITU recommendations.

UMTS is standardised by ETSI as a true third generation service/system with evolution paths from GSM, ISDN and DECT. UMTS is planned as a member of the IMT-2000 family. It is intended to specify roaming with other members of the IMT-2000 family based on marked need and business viability. It is intended to submit the defined terrestrial radio access system as a candidate to ITU. It will meet or exceed the essential ITU minimum requirements.

8.2 SMG policy on IMT-2000 Family Concept¹²

ITU SG11 accepted the IMT 2000 Family of Systems (IFS) concept in principle. This means that IMT 2000 will have a number of different systems as members. Annex 13 gives SMG view and describes the IFS concept and identifies concepts to realise global roaming within the IMT 2000 Family of Systems.

9 Services

9.1 Service Aspects¹³

Pre-UMTS systems have largely standardised complete sets of teleservices, applications and supplementary services which they provide. As a consequence, substantial re-engineering is often required to enable new services to be provided and the market for services is largely determined by standardisation. This makes it more difficult for operators to differentiate their services. UMTS aims to standardise service capabilities and not the services themselves. Service capabilities consist of bearers defined by QoS parameters and mechanisms needed to realise services. The standard will provide mechanisms to enable service providers and operators to create their own supplementary services, teleservices and end user applications. The standard will cover functionality provided by various network elements, the communication between these elements and the transfer and storage of associated data. The standard will provide:

- mechanisms to enable the creation of supplementary services including the creation and execution of appropriate MMI procedures to the user's terminal
- mechanisms to permit the definition of interworking functions, appropriate for the creation of teleservices and/or end user applications including the download and execution of these functions in the user's terminal and in appropriate network elements

UMTS service capabilities will take into account the discontinuous and asynchronous nature of most teleservices and end user applications in order to make efficient use of network resources (particularly radio resources). UMTS will also cater for applications which are able to adapt to a range of variations in quality of service.

The standardisation of service capabilities rather than the services themselves is a major differentiator between UMTS and pre-UMTS systems. However the support of speech, facsimile services and messaging shall be specified via standardisation. In particular a high quality default speech codec will be specified for UMTS.

UMTS aims to provide the user (subscriber, service provider or network operator) with a comprehensive set of services, features and tools which enable services to have the "same look and feel" wherever they are used (when roaming between networks and across geographic boundaries). UMTS also aims to offer a large degree of service personalisation (appropriate to the needs of the user) such that the user may remove his/her smart card from one terminal, insert it into another and have the "the same look and feel" to service provision maintained. This concept of "maintaining the same look and feel" wherever the terminal is used and/or whenever the smart card is taken out of one terminal and inserted into another is referred to as the Virtual Home Environment (VHE). It is planned that, as far as possible, the VHE should be realisable across GSM and

¹² SMG#24 meeting report, chapter 4.5, page 29, and TDoc 1132/97

¹³ SMG#24, Tdoc xxy, approved input from SMG1

UMTS. Since UMTS aims to be aligned with IMT-2000, the VHE must also be realisable across UMTS and other IMT-2000 family members.

UMTS will support multimedia services (services which utilise several media components). All calls shall have the potential of becoming multimedia calls and there will be no requirement to signal in advance any requirement for any number of media components. UMTS will therefore enable the user of a single terminal to establish and maintain several connections simultaneously and provide the flexibility to enable the addition and deletion of both resources and parties.

UMTS will support many advanced numbering concepts and addressing schemes such as number private numbering and alphanumeric addressing. Number portability features shall, within limits, enable the subscriber to change service provider, the service provider to change network operators, and the subscriber to change geographic location without changing numbers or addressing. Private numbering features will enable users to be addressed via short number or text sequences and schemes used may be devised by the subscriber, service provider or third party. Alphanumeric addressing schemes will enable "Internet style" addresses or user names to be used.

In addition to bi-lateral roaming relationships, UMTS shall provide for the automatic establishment of roaming relationships between different networks. It shall be possible for users to be handed over between UMTS networks subject to the establishment of appropriate roaming relations. Handover, for certain services, between UMTS and GSM systems (in both directions) shall be provided.

9.2 Location Services¹⁴

The requirement in a growing number of countries to be able to locate a Mobile Station in emergency situations makes location services mandatory for UMTS. There are a number of locations mechanism proposed for GSM and UMTS including the use of GPS.

T1P1.5 and SMG2 should work co-operatively to address location services.

9.3 Charging aspects¹⁵

Some conflicting elements of charging related aspects in UMTS 22.24 and TG.24 with MoU BARG which currently plans to establish UMTS charging principles in the year 1999 have been discovered. Discussions leading to clarifications are needed.

At the MoU BARG meeting nr. 40 (January 1998) it will be proposed to set up charging principles for UMTS within 1998 rather than 1999 (as stated previously) based on MoU 3GIG's document TG.24 version 3.0.0. MoU BARG's proposal is to set up a multi-skilled working party for that purpose (similar to the way it was done for CAGE2+) with members from MoU BARG, MoU 3GIG, ETSI SMG1.

Therefore there is no longer a need to issue a liaison statement to MoU BARG.

10 UMTS radio access

10.1 Basic requirements to the UMTS radio access

- 1) The UMTS radio interface shall meet at least the essential requirements for submission as a candidate technology for IMT-2000.
- 2) SMG2 will focus their work on the terrestrial radio interface until a final decision on UMTS satellite component is made.
- 3) Wireless Access to Fixed Networks is considered in the requirements for the UMTS Radio Interface in so far that this does not burden the solution with unnecessary complexity or performance degradation.

¹⁴ SMG#23 meeting report, part B, chapter 9.3, page 37

¹⁵ Based on SMG#23 meeting report, part B, chapter 9.3, page 38

- 4) An Aeronautical component will not be considered in the requirements for the UMTS radio interface.¹⁶
- 5) The sharing between DECT and UMTS is not an approved objective of standardisation.¹⁷
- 6) A value of 384 Kbit/s is a minimum requirement for the pedestrian environment. The value of 512 Kbit/s is seen as desirable.¹⁸

10.1.1 High level requirements relevant for the definition of the UMTS Terrestrial Radio Access UTRA concept¹⁹

NOTE: The high level requirements relevant for the definition of the UMTS Terrestrial Radio Access UTRA concept is given in Annex 02.

This section summarises the requirements for the UMTS Terrestrial Radio Access concepts. The purpose of this document is to enable the proposals for UTRA technologies to be developed and evaluated. UMTS 21.01 will be developed to give further details on the UMTS radio requirements

10.1.2 Support of speech by the UMTS access system²⁰

NOTE: Support of speech by the UMTS access system is given in Annex 3.

In developing the basic access system for UMTS, not only must the generic bearer services be defined, but it must be established that the major target applications for UMTS can be implemented using these bearer services in a spectrally efficient and cost effective manner. In this respect, it is important to recognise that the speech application differs from data services and the basic capabilities of UTRA should facilitate the efficient implementation of speech (with or without a single narrowband speech codec standard). These basic capabilities should include for example the support of variable source data rate, multi-level error protection and variable channel protection according to the instantaneous channel error rates.

The main points to be agreed for UMTS speech are that:

- speech will be an important [even if less important than data] service category (already agreed at SMG#20)
- a significant proportion of UMTS traffic will be narrowband speech, preferably coded using a common codec standard
- UMTS networks must be capable of implementing narrowband speech efficiently and at least to the same quality and capacity levels of GSM (including potentially the AMR codec). [More demanding targets may be considered.]

²¹A liaison statement from SMG11 to SMG in Tdoc SMG 337/97 recommends the definition of a high quality basic speech service including the speech and channel codecs and related end-to-end aspect, possibly based on AMR.

The recommendations of SMG11 were endorsed and will be included in their work.

10.1.2.1 AMR²²

AMR is good candidate and SMG agreed to support this as the working assumption. Further information is needed in order to make a firm decision.

SMG agreed that working together with ARIB on the default speech codec for UMTS should proceed, involving SMG11 and SMG2. SMG11 was requested to describe the scope of the co-operation at SMG#27. It was agreed to send a copy of the LS to SMG2 (Annex 3 of Tdoc SMG 367/98) to ARIB.

¹⁶ SMG#21 meeting report, 7.6.3, approved Tdoc SMG 265/97

¹⁷ SMG#21, meeting report, 7.2, based on Tdoc SMG192/97

¹⁸ SMG#21 meeting report, 7.6.3, based on Tdoc SMG 155/97

¹⁹ proposal to SMG#22, based on approved Tdoc SMG 478/97

²⁰ SMG#21 meeting report, 7.4, approved Tdoc SMG 292/97

²¹ SMG#22 meeting report, part B, chapter 7.6

²² SMG#26 meeting report, chapter 7.6.2, page 64

10.1.3 Essential requirements toward UMTS for private and business applications²³

NOTE: Essential requirements toward UMTS for private and business applications are given in Annex 04.

In conclusion the selection procedure and criteria for UMTS radio access scheme have to make sure that for private UMTS systems:

- a) Multiple unsynchronised systems can successfully coexist in the same environment.
- b) Basestations can be installed uncoordinated.
- c) No frequency planning is needed.
- d) No licence is needed to make use of the radio spectrum.
- e) The radio access scheme is suitable for low cost applications where range, mobility and user speed may be limited.
- f) A generic access profile can be defined, which guaranties
 - 1) interoperability of terminals from different manufacturers
 - 2) compliant UMTS terminals can be used in residential, business and public environment.

10.2 Procedure for the definition of the UMTS Terrestrial Radio Access²⁴

NOTE: Procedure for the definition of the UMTS Terrestrial Radio Access is given in Annex 05.

This section provides a description of the procedure for deriving the UMTS Terrestrial Radio Access (UTRA). The primary goal of this procedure is to ensure a timely definition of the UMTS Terrestrial Radio Access so that operational UMTS systems can be in place within the time frame set by market demand. A further goal of this procedure is to make it possible to submit one and only one candidate for IMT-2000 to ITU as result of UMTS work performed by SMG.

This procedure, for deriving the UMTS Terrestrial Radio Access (UTRA), will strengthen the co-operative working method based on the well proven consensus based standardisation within SMG. The procedure will be open for contributions from all participants. It aims to maximise the benefit from the expertise and research of different players in all aspects of radio access technology. This should result in a UMTS Terrestrial Radio Access (UTRA) with an overall performance superior to that obtainable by a traditional "beauty contest" type of selection.

Finally, this open and co-operative procedure will assist in putting all participants into an equal position for the implementation of the derived standard and the subsequent entry into the UMTS market place.

10.3 Time schedule for UMTS Terrestrial Radio Access definition²⁵

NOTE: The time schedule for UMTS Terrestrial Radio Access definition is given in Annex 06.

Milestones:

- | | |
|----|--|
| M1 | Definition of a limited number of UMTS Terrestrial Radio Access concepts, i.e. based on access technologies or combinations of them. |
| M2 | Selection of one UMTS Terrestrial Radio Access concept |

²³ SMG#21 meeting report, 7.6.1, Tdoc SMG 187/97

²⁴ SMG#21, 7.4, approved Tdoc SMG 163/97

²⁵ SMG#21, 7.4, approved Tdoc SMG 164/97

M3 Definition of key technical aspects of the UMTS terrestrial radio access (including carrier bandwidth, modulation, channel coding, channel types, frame structure, access protocols, channel allocation and handover mechanisms, cell selection mechanisms etc.)

²⁶SMG2 UMTS overall time-plan:

M4 Submission of UMTS to ITU-R in June

M5 Evaluation report to ITU-R in September (SMG2 has in its role of ITU-R evaluation group to prepare the UTRA proposal to ITU-R by the end of June 1998. The evaluation of the proposal should be completed by September 1998)

M6 Elaboration of technical description of UTRA completion ultimo 98

M7 elaboration of specifications completion ultimo 99

M8 correction based on experiences

M9 UMTS phase 2 standardisation start primo 2002.

10.3.1 Milestone M1²⁷

Regarding the UMTS terrestrial radio access (UTRA) definition the first milestone was reached, the approval of the following documents:

- high level requirements for the UTRA definition (Tdoc SMG 478/97)
- requirements for UTRA (UMTS 04.01, Tdoc SMG 431/97)
- evaluation procedures for UTRA (UMTS 04.02, Tdoc SMG 432/97)
- approval of a limited number of concept groups for further study :
 - Wideband CDMA
 - OFDMA
 - Wideband TDMA
 - Wideband TDMA/CDMA
 - ODMA

10.3.2 Milestone M2²⁸

ETSI SMG#24bis has approved selection of UTRA by consensus.

This consensus agreement contains the key elements and advantages of WCDMA and TD/CDMA, and contains the following elements:

- 1) In the paired band we adopt the radio access technique proposed by the ETSI Alpha group, that is WCDMA (Wideband Code Division Multiple Access), Tdoc SMG 903/97.
- 2) In the unpaired band, we adopt the radio access technique proposed by the ETSI Delta group, that is TD/CDMA (Time Division/Code Division Multiple Access), Tdoc SMG 897/97.
- 3) In the process in selecting the technical parameters the following shall be the objectives:

²⁶ SMG#25 meeting report, part B, page 52, chapter 7.4

²⁷ SMG#22 meeting report, part A, chapter 2

²⁸ SMG#24bis meeting report, part A, chapter 2.5 and TDoc 39/98,

Low cost terminal

Harmonization with GSM

FDD/TDD dual mode operation

Fit into 2 * 5 MHz spectrum allocation

NOTE: NTT DoCoMo participated as an observer in SMG#24bis and expressed support for ETSI SMG decision.

10.3.3 Milestone M3²⁹

SMG#26 approved Tdoc SMG 391/98 with the following modifications:

in section 1: "The document is divided into a main part containing a description of the radio access system and three Annexes."

In section A1.1.3: "The flexibility of the SRTT allows for an optimisation of the transmission and receiver chains according to the specific deployment scenario such as cellular or FWA. Indeed, the SRTT is designed to be future proof taking advantage of extended range technologies such as adaptive antennas and antenna diversity in the downlink but also interference cancellation techniques."

With these modifications, Tdoc SMG 391/98 was approved unanimously (no objection, no abstention).

A cover letter to ITU-R has been prepared by SMG. The cover letter clearly states SMG's willingness to be an active participant in the ITU-R TG8/1 WG5 consensus building group.

10.3.4 Milestone 4³⁰

With some smaller modifications, Tdoc SMG 391/98 was approved unanimously (no objection, no abstention).

SMG#26 approved this document to be submitted to ITU, together with a short document listing the IPR status for UTRA within ETSI is provided to ITU for information.

10.4 Principles for hardware validations during the definition of the UMTS Terrestrial Radio Access (UTRA)³¹

NOTE: The principles for hardware validations during the definition of the UMTS Terrestrial Radio Access (UTRA) are given in Annex 07.

Comprehensive hardware test-beds will not be used during the selection and definition procedure of the UMTS Terrestrial Radio Access (UTRA) as described in "Procedure for the definition of the UMTS Terrestrial Radio Access".

²⁹ SMG#26 meeting report, part B, chapter 7.2.2, page 58 and 59

³⁰ SMG#26 meeting report, part B, chapter 7.2.2, page 58 and 59

³¹ SMG#21 meeting report, 7.4, approved Tdoc SMG 165/97

10.5 Dual mode operation GSM/UMTS and handover³²

Some conclusions on dual mode of operation GSM/UMTS and handover:

- GSM only, UMTS only and GSM/UMTS terminals should be allowed.
- GSM - UMTS handover is needed in both directions. Restrictions of the applicability of handover may be necessary for particular services and when services are different between the systems.
- Support of handover between UMTS and GSM entails modifications of the GSM specifications.
- GSM networks need to be protected from unwanted side-effects caused by functions to support cross handovers.

10.6 Selection procedures for the choice of radio transmission technologies of the UMTS³³

The document UMTS30.03 "Selection procedures for the choice of radio transmission technologies of the UMTS" was approved in order to put it under change control, even if SMG feels that it has to be revised.

10.7 Establishment of SMG's "Evaluation group of the IMT-2000 RTT's Radio Transmission Technologies"

The establishment of SMG2 as an evaluation group was approved.

³⁴Evaluation report to ITU-R in September (SMG2 has in its role of ITU-R evaluation group to prepare the UTRA proposal to ITU-R by the end of June 1998. The evaluation of the proposal should be completed by September 1998)

10.8 Harmonisation of UTRA with other Radio Access Schemes³⁵

It was concluded that:

- harmonization has been already achieved to a much larger degree than it was expected some time ago;
- the idea of harmonization at the expenses of the SMG defined solution is not acceptable;
- the target harmonization must be combined with better performance;
- further proceeding by direct interaction between processes;
- time to introduction of products to market must be considered.

³⁶In the extensive discussion it was clarified that SMG has already the appropriate structure to study the technical aspects of convergence under the proven leadership of SMG2

³² SMG#22 meeting report, part B, chapter 7.3

³³ SMG#22 meeting report, part B, Chapter 7.4.1, page 34

³⁴ SMG#25 meeting report, part B, page 52, chapter 7.4

³⁵ SMG#25 meeting report, part B, page 50, chapter 7.1.3

³⁶ SMG#26 meeting report, part B, chapter 7.3, page 61

10.9 Report on Essential IPRs³⁷

ETSI legal adviser, presented the *Report on Essential IPRs declared in relation to the work of SMG#27* in Tdoc SMG P-98-786 (revision of Tdoc SMG P-98-732), including references of IPRs which have been notified to ETSI as being essential to UMTS by 9 October, 1998.

Note: All references pertaining to essential IPRs declared to ETSI are publicly available on the ETSI web site <http://www.etsi.org>.

11 Network aspects

UMTS will use the general concepts of the GMM architecture framework³⁸ mainly the separation in four domains

- user terminal equipment
- access networks
- core transport networks
- services applications

UMTS will be based on one new generic radio access network³⁹.

The first phase of UMTS core transport network functionality should be based on an evolution of GSM and ISDN core transport networks.⁴⁰

The work on both radio interface and network aspects must go in parallel. It is necessary that the priority in UMTS standardisation respects the fact that the network issues are equally important as radio aspects, since UMTS is defined not only for 2002 but also for 2010 and therefore modularity and flexibility must be built in⁴¹.

12 UMTS satellite component

UMTS satellite component is integral part of UMTS. SMG will specify the UMTS satellite component when potential customers express their needs.⁴²

Regarding the UMTS satellite component it was agreed within SMG and with the SES Chairman based on discussions with interested operators and the European Commission:

- there is no requirement for a complete system standard for S-UMTS
- standardisation should be focused to dual mode of operation and terminals between satellite based UMTS and terrestrial UMTS
- the necessary specifications for satellite based UMTS will be developed as a part of UMTS under leadership of SMG

TC SES will develop the necessary specifications requested by the satellite directive and the type approval directive under a subcontract between SMG and SES.⁴³

³⁷ SMG#27 meeting report, part B, chapter 7.7.3.1, page 64

³⁸ SMG#19, 8.61, approved Tdoc SMG 560/96 (Tdoc SMg539/96)

³⁹ GMM report, recommendation 4

⁴⁰ GMM report, recommendation 4

⁴¹ SMG#20 meeting report, 7.6.1, based on Tdoc SMG 647/96

⁴² SMG#22 meeting report, part B, chapter 2

⁴³ SMG#22 meeting report, part A, chapter 2

12.1 S-PCN - UMTS interference⁴⁴

ERM ad hoc on satellite services: Concerning potential problem with too high out of band spurious emissions in the 1,6 GHz range and co-existence problems with UMTS in the 2 GHz band, it was proposed to use preliminary figures for the S-PCN emissions, and to adapt them when the UTRA proposal is defined. To live around 6 months with preliminary figures is was found acceptable by CEPT SE.

13 Operation and maintenance

⁴⁵The ETSI Board endorsed the agreement that had been reached for the TMN work responsibilities between SMG and TC TMN. After full consideration of the work of both bodies the following agreement was reached:

- i) SMG6 will continue to undertake network management standardization activities on GSM as at present (ie no GSM network management standardization will be undertaken within TC TMN);
- ii) TC TMN will undertake network management standardization activities on UMTS, for the Q and X interfaces and for network management architecture and modelling as illustrated in figure 1 below. (Note: this will require input from SMG);
- iii) SMG will continue to undertake UMTS system internal management standardization including data and information flows within the network element and between network elements level as illustrated in figure below. (Note: this will require input from TC TMN);
- iv) All deliverables produced will require the collaboration and co-operation of both SMG and TC TMN.

UMTS network management standardization activities

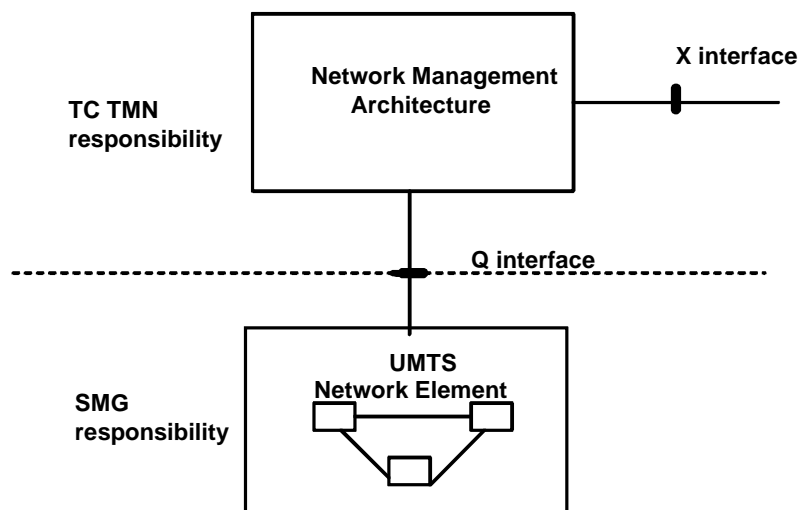

The transfer of the UMTS work item "Overall principles of the OAM for the UMTS" to TC TMN was approved by SMG #25.⁴⁶

⁴⁴ SMG#22 meeting report, part B, chapter 7.4.4

⁴⁵ ETSI Board#09 meeting report, 07 - 08 October 1997

⁴⁶ SMG#25 meeting report, part B , page 54, chapter 7.6

14 Other aspects

14.1 Emergency call⁴⁷

It was concluded that clarifications on the UMTS emergency call concepts are needed.

14.2 Global pilot channel⁴⁸

Tdoc SMG 557/97 was approved with some modifications as an SMG initial view, but interested parties are invited to contribute on the matter (see Annex 9).

Any global pilot channel may be considered to work independent of the UTRA and if required may be implemented as an overlay mechanism.

14.3 Regulatory issues⁴⁹

SMG sees the leadership for discussion on regulatory issues within TG1 and the UMTS Forum. SMG7 should open a work item on UMTS testing and type approval but start work when a sufficient basis is established.

Some indications from the Commission: ⁵⁰

- The Commission recognises the role of ETSI to define the 3rd generation standard for the European Economic Area
- ETSI must use clear transparent rules in that definition process

14.4 USIM (UMTS SIM) Card⁵¹

SMG have been looking at the requirements for the UMTS (Third Generation) USIM, noting particularly, the requirement that UMTS evolves from GSM. As part of the evolutionary approach from GSM to Third generation systems, it is a requirement that 3G terminals support existing (Phase 2) SIMs (at three volts, but not five volt SIMs), but it is not a requirement that GSM terminals support 3G USIMs. It is the strong opinion of SMG that the UICC (UMTS Integrated Circuit Card) is a mandatory element of Third Generation systems.

It is recognised that the existing physical interface should remain unchanged (to accommodate the need for interworking with GSM), however, that there may be the need to enhance the interface, both in terms of protocol (for example, employing the T=1 protocol), and speeding up the bit transmission rate across the interface.

It is recognised that the existing two physical sizes may prove to be limiting to mobile equipment (ME) designs for 3G mobiles, so consideration is being given to a third physical size of SIM, (e.g. a cut down version of existing "Plug-in" SIM, without affecting the existing mandatory physical interface). The UICC / terminal interface remains mandatory.

The other important feature of the SIM is the SIM Application Toolkit; this is a powerful tool for operators, and can be easily exploited and enhanced for 3G operations, especially in the area of Virtual Home Environment. Allied to this is the security for the Toolkit, where end-to-end messaging between the Application area in the SIM and its partner entity in, or behind, the network, can be secured, to prevent fraud or interception. Enhancements exploiting newer bearer services will be included for the Toolkit.

The next generation SIM will be a multi-application card, including support for application loading; SMG fully expect this work to be completed and approved in June 1999.

⁴⁷ SMG#22 meeting report, chapter 7.3

⁴⁸ SMG#22 meeting report, part B, chapter 7.4.1, page 35

⁴⁹ SMG#23 meeting report, part B, chapter 9.2.3, page 36

⁵⁰ SMG#24bis meeting report, part B, chapter 2.1, page 3, TDoc 22/98

⁵¹ SMG#27s meeting report, part B, chapter 7.9, page 67

It is the opinion of SMG that the existing SIM technology and functionality is an ideal baseline platform for early third generation systems; it is recognised that there will of necessity be alterations and additions to the file structure in the existing SIM to accommodate UMTS functionality, but this is believed to be easily undertaken.

15 Relationship to other bodies

15.1 Relationship to ITU⁵²

A work program for contributions to ITU TG8/1 and SG11 was agreed (Tdoc SMG 570/97). Two full-time co-ordinators were appointed. Basis of the work is the IMT-2000 family concept (Tdocs 293/97 and 491/97), which was endorsed by an ITU SG11 rapporteurs meeting on 9 - 13 June 97. SMG has established communication with ITU by giving ITU contributions an SMG endorsement by approval at SMG plenary.

15.1.1 Relationship to ITU-T

SMG has increased influence on SG11 standardisation work on the IMT-2000 network aspects. Based on SMG contributions SG11 has accepted the IMT-2000 family concept. It was agreed that number of European delegates attending SG11 should be increased.⁵³

15.1.1.1 Relationship to ITU SG11⁵⁴

The ETSI Board has designated TC SPS as the lead committee for coordinating contributions to ITU-T Study Group 11. SPS has set up a Task Force to fulfil this task which is currently chaired by Mike Briggs (BT). ETSI SMG's coordinator for contributions to the ITU-T (currently David Williams (PT SMG)) works closely with Mr. Briggs in the SPS Task Force.

15.1.2 Relationship to ITU-R TG8/1

SMG evaluation group has been registered at ITU-R TG8/1.

15.2 Relationship to Japan ARIB/TTC⁵⁵

Recently ETSI SMG has started dialogue with Japanese standardisation bodies, ARIB (Association of Radio Industry and Businesses) responsible for IMT-2000 radio aspects in Japan, and TTC (Telecommunication Technology Committee) responsible for IMT-2000 network aspects in Japan. The exchange of information has been agreed; co-operation will be discussed between ETSI and ARIB/TTC (see Annex 10 and Annex 11). The area of common interest should cover work on the 3rd generation systems including both network and radio aspects.

⁵⁶The proposed agreement SMG - TTC contains the point 1 saying:

“(1) It was proposed to have a single set of specifications for year 2002's system based on evolved GSM core network taking into account the Japanese requirements.

Point 1 was approved (on an interim basis because such a decision is in the mandate of the Globalisation Group) as SMG aim for technical work until Globalisation Group and Board decide on formal co-operation

⁵² SMG#22 meeting report, part A, chapter 2

⁵³ SMG#20 meeting report, 7.2.2, based on Tdoc SMG 689/96

⁵⁴ Approved by correspondence after SMG#25

⁵⁵ SMG#22 meeting report, part A, chapter 2

⁵⁶ SMG#25 meeting report, part B, page 12, chapter 5.5

15.3 Relationship with GMM CG⁵⁷

SMG nominated delegates to represent SMG in the GMM Co-ordination group.

15.4 Relationship to UMTS Forum

A co-operation agreement between ETSI and the UMTS Forum has been signed. It was endorsed by SMG. ⁵⁸

The focus of the UMTS Forum work are market, regulation and spectrum aspects. Mr. Hillebrand has been appointed as ETSI representative in UMTS Forum Steering Group.

UMTS Forum working groups and ETSI STCs should appoint liaison persons who attend Forum's and ETSI's groups.

15.5 Relationship to GSM MoU 3GIG

SMG receives regular information on the progress of the GSM MoU 3GIG body and all relevant output documents are considered by SMG plenary and its STCs.

15.6 Relationship to ACTS

15.7 Relationship to ATM Forum

15.8 Relation to China MPT/RITT

Editorial note: The text should be reworded together with the Chinese delegation.

It was a common point of view, that Chinese requirements will often be interesting for other countries as well and that a co-operation on work items might be useful as well for the Chinese operators as for the operators present in SMG.

China mainly adopts international standards such as ITU or ISO standards; in addition, it adopts some advanced regional standards, such as ETSI, TIA and other standards.

15.9 Relation to UGG UMTS Globalization Group

There is an emerging consensus in the UMTS Globalization Group to create a globalised specification group for GSM-based UMTS (draft scope statement in annex 2). This specification group would be open to committed manufacturers, network operators, regulators and other market players as members. It is proposed that ETSI should initiate the creation of this group in close partnership with relevant national or regional standardisation organisations such as T1, ARIB/TTC and RITT⁵⁹

⁶⁰SMG decisions: SMG#25 decided

- to terminate the mandate for exploratory missions issued by SMG#24 (Tdoc 1154/97);
- to endorse the draft guidelines for SMG representatives in the UMTS Globalization Group in annex 4;
- to appoint the permanent SMG representatives to the UMTS Globalization Group: Fred Hillebrand, François Grassot, Gunnar Sandegren;

Progress of UGG has been reported at each plenary.

⁵⁷SMG#20,meeting report, 7.1, based on Tdoc SMG 708/96

⁵⁸SMG#19 meeting report,8.6.2, Tdoc SMG547/96

⁵⁹SMG#25 meeting report, part B, page 13, chapter 5.5

⁶⁰SMG#25 meeting report, part B, page 15, chapter 5.5

16 Work planning and standardisation organisation

Whole of section 16 will be revised following the final decisions on 3GPPP.

16.1 UMTS work programme within ETSI

The following picture illustrates distribution of the UMTS standardisation within ETSI.

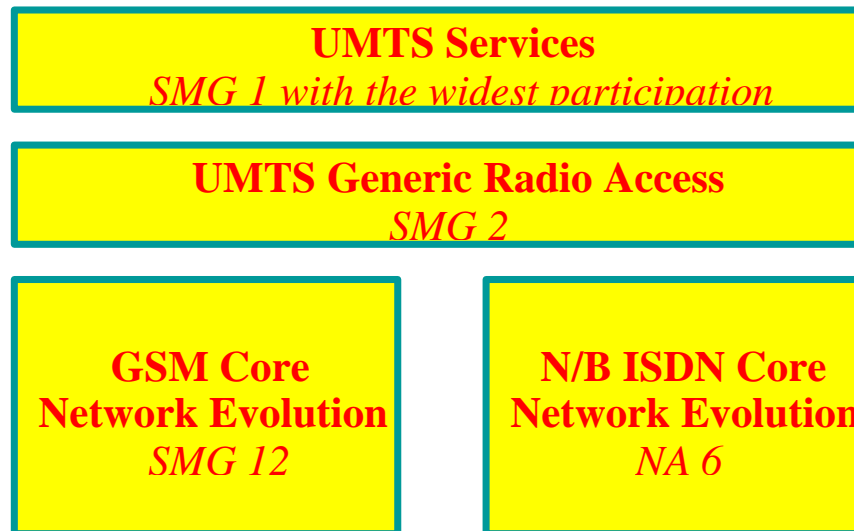

Technical co-ordination in order to facilitate convergence should be implemented by a bi-lateral co-ordination mechanism between the groups responsible for the technical specifications. The concept of a superior independent co-ordination /management body was rejected.⁶¹

16.2 SMG's UMTS Work programme

The SMG's UMTS work programme is maintained by PT SMG. New versions are produced by PT SMG and are presented with CR to SMG for approval.⁶²

⁶³SMG#26 decisions:

- Each STC should start review of UMTS work program. They should review phase 1 and recommend which work of other bodies can be incorporated in UMTS work program.
- The document Tdoc SMG 420/98 (together with existing UMTS work program) should be used as a base for the UMTS work program review.

16.2.1 Document Structure of GSM and UMTS Release 99 Specifications⁶⁴

: SMG1 had asked WOME to look into proposals for a Release 99 specification structure (for GSM and UMTS). WOME studied the requirements, in particular it agreed as a working assumption that the set of specifications for UMTS together with all referenced documents shall be self-contained for an educated reader, and that the referenced documents shall be publicly available. WOME concluded that a central problem is the maintenance, improvement and correction of the common kernel where the same changes have to be adopted for GSM and UMTS. For the Japanese side when there is a common Core

⁶¹ SMG#19 meeting report, section 8.6.2, , based on Tdoc SMG 516/96

⁶²SMG#26 meeting report, chapter 7.8, page 65

⁶³ SMG#26 meeting report, chapter 7.3, page 61

⁶⁴ SMG#27 meeting report, part B, chapter 5.6.1, page 12

Network protocol for UMTS and GSM, modifications of the common kernel must be in the responsibility of 3GPP. Further considerations are necessary. For stage 3 specifications in particular, i.e. the actual protocols, it is very important to have only one specification for one protocol.

An initial examination of Methods A, B, B' and C were made:

- **Method A:** The specification structure is based on the GSM structure and the UMTS functionality is included into the GSM specifications. The result will be common GSM/UMTS specifications. The default is that everything is valid for both GSM and UMTS. GSM specific parts are marked and UMTS specific parts are marked, respectively.
- **Method B:** A new, separate specification series for UMTS is used which includes references to appropriate GSM specifications.
- **Method B':** A new, separate specification series for UMTS is used. The GSM set of specifications includes references to appropriate UMTS specifications.
- **Method C:** A new, separate specification series for UMTS is used but instead of references to GSM specifications the appropriate parts of GSM specifying text are copied into those UMTS specification(s).

WOME did not conclude on one of the methods (or a mixture of some of them). WOME reported to SMG#27 that it would be ready to continue the investigation if SMG so wishes.

16.3 Organisation within SMG

SMG performs the UMTS co-ordination.⁶⁵

In order to streamline the UMTS part in SMG plenaries, to further develop the UMTS specifications structure and work programme, to propose a plan for the ITU related work in SMG, meetings of the Steering Group SMG may be held. Outcome of such meetings will be presented as proposals to SMG members in due course.⁶⁶

16.3.1 STC's and other groups responsibilities

SMG1	UMTS services and service capabilities
SMG2	GRAN Generic Radio Access Network
SMG3	UMTS network architecture
SMG4	UMTS data
SMG6	UMTS network management
SMG9	USIM - UMTS SIM
SMG10	UMTS security aspects
SMG11	UMTS speech aspects
SMG12	UMTS System Architecture
PT SMG	UMTS program management support of STCs
WOME	Ad-hoc Group Working Methods
AG SMG	Advisory Group SMG

⁶⁵ approved by SMG by correspondence after STG meeting 05 March 1997

⁶⁶ SMG#21 meeting report, based on section 7.2

NOTE 1: The roles of other STCs are for further study.

16.3.2 Proposal on the future organisation of GSM and UMTS standardisation⁶⁷

The GSM community is now a global community of operators and manufacturers but has experienced difficulties to open up for a wider participation in ETSI/SMG. Organisations from outside Europe still cannot become full ETSI members. Even voting rights for associate members in Technical Bodies were not endorsed by ETSI's General Assembly in November 97. Present working methods with ANSI T1P1 on common GSM specifications are proven as best possible solution for co-operation with other standard bodies, but they are very complex. This situation calls for a closer and more efficient overall co-operation. The GSM MoU Association and especially the APIG (Asian Pacific Interest Group) of GSM MoU have expressed their desire to participate fully in GSM work and in Third Generation standardisation and to ensure roaming with Japan.

For these reasons, these three companies proposed the establishment of SMG as the joint working structure among the interested bodies to produce GSM and UMTS standards for ETSI (as an ETSI partnership project) and for the other interested bodies, avoiding parallel work and overhead co-ordination; current budget allocations for ETSI/SMG to be considered as an asset for this possible joint working structure; the SMG Chairman to carry out an exploratory mission in this sense.

Decisions on the matter:

- It was agreed by SMG#24 as important that both GSM and UMTS are included in the proposal.
- Time plan: It was agreed to give report into SMG#24bis and SMG#25.
- SMG#24 endorsed the paper TDoc 1154/97 (see Annex 12)

⁶⁸SMG decisions: SMG#25 decided

- to terminate the mandate for exploratory missions issued by SMG#24 (Tdoc 1154/97);

16.3.2.1 SMG26 on Globalisation

⁶⁹SMG#26 gave guidance to the SMG representatives in that group, mainly

- confirming the evolutionary aspects,
- emphasizing the necessity of continuity of work, and

recommending the inclusion of UMTS Radio, GSM Radio, UMTS services (with derived GSM services) and GSM evolution Core Network in the scope of 3GPP.

⁷⁰Decision of SMG#26:

- The common position of SMG#26 (with reservation of one company) was expressed that the concept of GSM-evolution UMTS core network shall be the same for GSM and UMTS radio access was confirmed; SMG#26 also confirmed the requirements for transitions (handover etc.) between GSM and UMTS radio - clear decisions since long.
- The common position of SMG#26 (with reservation of one company) was expressed that 3GPP should contain the UMTS Radio, GSM Radio, UMTS services (with derived GSM services) and GSM evolution Core Network:
 - 1) Whatever the chosen organisation, the timely development of the GSM specifications evolutions shall be possible and mechanisms shall be implemented in order to avoid any blocking of these specifications evolutions (radio and core network).
 - 2) In order to implement statement 1), days shall be devoted to the GSM evolution during the meetings of the plenary of « 3GPP » if and when it is created. This shall hold as well for the committees or working groups reporting directly or indirectly to the 3GPP.

⁶⁷ SMG#24 meeting report, part B, chapter 3.3 and TDoc 1154/97

⁶⁸ SMG#24 meeting report, part B , page 15

⁶⁹ SMG#26 meeting report, part A, page 2, chapter 4

⁷⁰ SMG#26 meeting report, part B, chapter 5.6, page 13 and 14

- The continuity of work which is now under responsibility of SMG must be maintained during transition and in the new environment without delays.

16.3.2.2 Extraordinary General Assembly meeting, 29 September 1998⁷¹

VOTE 4

QUESTION:

Do you agree that the GA endorses the following principles for the forthcoming negotiations:

to recommend ETSI to initiate an ETSI Partnership Project (EPP) to be known as "3GPP" for third generation mobile system specification work.

The 3GPP will be a partnership between ETSI and recognized Standards Developing Organizations and other partners; industrial entities are Members of 3GPP and provide the technical input.

The 3GPP will develop specifications for the initial phase of a complete third Generation Mobile System based on UTRAN and evolved GSM core network (a "G-UMTS" system).

To initiate the setting up of an ETSI Project (EP) for UMTS:

the new ETSI Project UMTS will collect current and future ETSI activities relevant to UMTS outside those G-UMTS areas to be handled in the 3GPP.

Furthermore it is agreed that:

Work on GSM standardization needs to continue, for example, for those network operators who do not get a UMTS licence. It is proposed that this work should remain in ETSI itself for the time being at least. For this and other reasons, it is proposed that ETSI SMG should continue to exist.

No duplication of work between 3GPP and ETSI EP UMTS, new SMG.

Total weight of votes cast: 1475

Yes 1394

No 81

Number of invalid ballots 0

Result of VOTE 4 was 94.5 % in favour of the proposal.

16.4 MoU for Voluntary Funding ⁷²

The STF SMG FTF proposes that

- an MoU for Voluntary Funding (MoU VFS) should be set up.
- That MoU VFS would agree on financial support of STF SMG activities not covered from other sources.
- The MoU VFS would be open to all parties and ideally all active SMG members should participate, however it is anticipated that initially a few larger players would be involved and thus take the lead.

SMG#27 decisions on the matter:

- SMG#27 acknowledged the results of the group as an excellent basis for future work.
- SMG#27 noted the next step that interested parties get together and determine the way forward.
- SMG#27 decided that the task force should stay in office in order to follow the future development and to become active if necessary.

⁷¹ ETSI Extraordinary GA meeting, 29 September 1998, Vote 4

⁷² SMG27 meeting report, part B, chapter 5.5, page 9 and 10

Annex 1: (*Editorial note: To be updated in order to reflect the current situation*) Third Generation Standardisation Policy : Relation between IMT-2000 and UMTS

Tdoc SMG 293/97

(revision of Tdoc SMG 290/97)

Title: Third Generation Standardisation Policy : Relation between IMT-2000 and UMTS

Source: ETSI SMG

Date: February 28, 1997

1 Interest of USA, Japan and Europe

1.1 USA

- General interest to promote the US PCS philosophy regarding regulation and standardisation
- Interest of the entire PCS community in Third Generation
 - Industry policy interest to get an IS95 CDMA evolution air interface and an IS41 evolution network protocol approved as IMT-2000
 - Interest of the PCS 1900 community in an evolution path from GSM towards Third Generation
- The interest of the IS54/136 (US-TDMA) community should be explored.

Japan

- Japan wants a new Third Generation System, which can be deployed to the world market and provides world wide roaming very soon.
- MPT does not expand spectrum for PDC. Since the market in Japan has a very high growth, the Japanese operators need a new system by 2000.
- Japan invests huge resources into IMT-2000 work and procedures "J-IMT-2000" drafts in their national standardisation organisations. These documents are then submitted to ITU. Japan is not pursuing a national standard. Therefore the Japanese national standards organisations do only have the mandate to produce input to ITU since ITU is perceived by the Japanese as the only body producing International Standards.
- Japan developed a three phases approach for "J-IMT-2000"
 - Phase 1: basic, like PDC/PHS 2000
 - Phase 2: several hundred kbit/s 2003-5
 - Phase 3: broadband 2010
- Arrangement to provide roaming between IMT-2000 systems in Japan and Korea for commercial use in 2002.

Europe

An intensive discussion in the UMTS Task Force and Forum and within ETSI reviewed the vision of UMTS and came to the following conclusions:

- UMTS must be a true third generation service and system
- UMTS will have an evolution path from GSM, ISDN and from DECT as an access infrastructure.

- UMTS should be developed in phases:
 - Consensus on the UMTS vision, basic parameters of the standard (and the radio definition framework) by the end of 1997
 - UMTS operation possible in 2002
 - Evolution in phases after 2002
- UMTS is based on the GMM architecture framework.
- A UMTS BSS will be developed as a generic radio access.
- Core networks supporting UMTS are market driven evolutions of GSM and ISDN (including CTM).
- UMTS is part of the system family developed by ETSI for the world market. An open worldwide participation in this process is encouraged.
- UMTS is a basis for the European Third Generation Plan spectrum plan.

International agreed Views

FAMOUS Agreements of May 95 on the Standardisation of the Third Generation

The agreed FAMOUS recommendations of May 1995 recognize the different market needs in different regions. They call for:

- evolution paths from all second generation systems
- interstandard interworking between second generation systems as a path to global roaming
- global standards should address the kernel of services and interfaces necessary for international compatibility
- regional standardisation organisations should specify the details
- regional standardisation bodies should co-operate towards service interworking

RAST

The global Radio Standards meeting held in conjunctions with Global Standards Collaboration meetings (September 1996, Korea) have discussed the objectives and work plans for IMT-2000 and has concluded the following:

“It was evident that the timing and the need for IMT-2000 are not interpreted in the same way by all PSOs. However, some form of global coexistence (roaming!) of various 3rd generation systems will be necessary”.

2.3 ETSI's GMM Standardisation Framework

ETSI studied relevant questions in the GMM (Global Multimedia Mobility) standardisation framework studies. These concluded that there should be one new generic radio access network for UMTS and several core transport networks.

Conclusions

IMT-2000 Family Concept

Market needs and interests are different between the regions. It should therefore be recognised that there will be several different IMT-2000 systems based on a common frame work. All efforts should be made to enable roaming between these different IMT-2000 systems. These systems should be seen as a IMT-2000 family.

3.2 Role of ITU

ITU should focus on:

- recognition of the IMT-2000 family concept
- register IMT-2000 family members
- facilitate roaming between members of the IMT-2000 family

- service interworking between IMT-2000 systems
- framework standardisation
- seek commonalities between IMT-2000 systems
- free circulation issues
- spectrum issues.

Role of ETSI

ETSI should provide regularly focused information to ITU on GSM phase 2+ and UMTS.

ETSI work should focus on:

- intensify 3rd generation work
- standardisation of UMTS
- concentrate contributions to ITU on framework standardisation, service interworking and roaming between members of the IMT-2000 family
- submit a terrestrial radio access system candidate, which meets or exceeds essential ITU requirements as a member of the IMT-2000 family.

Relation between IMT-2000 and UMTS

Although ETSI standards have a good international track record, many countries are bound to follow ITU recommendations. So to ensure world market access for UMTS there is a need for an ITU IMT-2000 label also on UMTS in some appropriate ITU recommendations.

UMTS is standardised by ETSI as a true third generation service/system with evolution paths from GSM, ISDN and DECT. UMTS is planned as a member of the IMT-2000 family. It is intended to specify roaming with other members of the IMT-2000 family based on marked need and business viability. It is intended to submit the defined terrestrial radio access system as a candidate to ITU. It will meet or exceed the essential ITU minimum requirements.

Document History:

Version	Document	Status
	Tdoc SMG 164/97	Presented to SMG#21. Approved with revisions.
Version 21.0	Tdoc SMG 190/97	Approved SMG#21 Version. Sent as a liaison statement to ETSI Board, UMTS Forum, MoU GSM, GMM Co-ordination Group, T1P1
Version 21.2	Tdoc SMG 193/97	Introduces DECT evolution path

Annex 2: Universal Mobile Telecommunications System; High level requirements relevant for the definition of the UMTS Terrestrial Radio Access (UTRA) concept

1 Introduction

This document summarises the requirements for the UMTS Terrestrial Radio Access concepts. The purpose of this document is to enable the proposals for UTRA technologies to be developed and evaluated. UMTS 04.01 will be developed to give further details on the UMTS radio requirements.

2 Key Requirements

The following table summarises all the key requirements identified for UMTS Terrestrial Radio Access concept:

NOTE: Not all combinations of options are required; for details see UMTS 04.01.

Key Requirements	Description
	Bearer capabilities
Maximum User Bit Rates	<p>The UTRA should support a range of maximum user bit rates that depend upon a users current environment as follows:</p> <p>Rural Outdoor⁷³: at least 144 kbit/s (goal to achieve 384 kbit/s), maximum speed: 500 km/h</p> <p>Suburban Outdoor⁷⁴: at least 384 kbps (goal to achieve 512 kbit/s), maximum speed: 120 km/h</p> <p>Indoor/Low range outdoor⁷⁵: at least 2Mbps, maximum speed: 10 km/h</p> <p>It is desirable that the definition of UTRA should allow evolution to higher bit rates.</p>
Flexibility	<p>Negotiation of bearer service attributes (bearer type, bit rate, delay, BER, up/down link symmetry, protection including none or unequal protection),</p> <p>parallel bearer services (service mix), real-time / non-real-time communication modes, adaptation of bearer service bit rate</p> <p>Circuit and packet oriented bearers</p> <p>Supports scheduling (and pre-emption) of bearers (including control bearers) according to priority</p> <p>Adaptivity of link to quality, traffic and network load, and radio conditions (in order to optimise the link in different environments).</p> <p>Wide range of bit rates should be supported with sufficient granularity</p> <p>Variable bit rate real time capabilities should be provided.</p> <p>Bearer services appropriate for speech shall be provided.</p>
Handover	<p>Provide seamless (to user) handover between cells of one operator.</p> <p>The UTRA should not prevent seamless HO between different operators or access networks.</p> <p>Efficient handover between UMTS and 2nd generation systems, eg GSM, should be possible.</p>
	(continued)

⁷³ The specified bit rate will be available throughout the operator's service area, with the possibility of large cells

⁷⁴ The specified bit rate will be available with complete coverage of a suburban or urban area, using microcells or smaller macrocells

⁷⁵ The specified bit rate will be available indoors and localised coverage outdoors.

(continued)

Key Requirements	Description
	OPERATIONAL REQUIREMENTS
Compatibility with services provided by present Core Transport Networks	ATM bearer services GSM services IP (internet protocol) based services B/N-ISDN services
Radio Access Network Planning	If radio resource planning is required, automatic planning shall be supported.
Public network operators	It shall be possible to guarantee pre-determined levels of quality-of-service and quality to public UMTS network operators, in the presence of other authorised UMTS users.
Private and residential operators	The radio access scheme should be suitable for low cost applications where range, mobility and user speed may be limited. Multiple unsynchronised systems should be able to successfully coexist in the same environment. It should be possible to install basestations without co-ordination. Frequency planning should not be needed.
	EFFICIENT SPECTRUM USAGE
Spectrum efficiency	High spectrum efficiency for typical mixtures of different bearer services. Spectrum efficiency at least as good as GSM for low bit rate speech.
Variable Asymmetry of Total Band Usage	variable division of radio resource between uplink and down link resources from a common pool (NB: This division could be in either frequency, time, or code domains)
Spectrum Utilisation	Allow multiple operators to use the band allocated to UMTS without co-ordination. ⁷⁶ It should be possible to operate the UTRA in any suitable frequency band that becomes available such as first & second generation system's bands
Coverage / Capacity	The system should be flexible to support a variety of initial coverage/capacity configurations and facilitate coverage/capacity evolution Flexible use of various cell types and relations between cells (e.g. indoor cells, hierarchical cells) within a geographical area without undue waste of radio resources. Ability to support cost effective coverage in rural areas
	(continued)

⁷⁶ NOTE: the feasibility of spectrum sharing requires further study.

(concluded)

Key Requirements	Description
	Complexity/cost
Mobile Terminal viability	Handportable and PCM-CIA card sized UMTS terminals should be viable in terms of size, weight, operating time, range, effective radiated power and cost.
Network complexity and cost	The development and equipment cost should be kept at a reasonable level, taking into account the cost of cell sites, the associated network connections , signalling load and traffic overhead (e.g. due to handovers).
Mobile station types	It should be possible to provide a variety of mobile station types of varying complexity, cost and capabilities in order to satisfy the needs of different types of users.
	Requirements from bodies outside SMG
Alignment with IMT 2000	UTRA shall meet at least the technical requirements for submission as a candidate technology for IMT 2000 (IMT-2000)
Minimum bandwidth allocation	It should be possible to deploy and operate a network in a limited bandwidth
Electro-Magnetic Compatibility (EMC)	The peak and average power and envelope variations have to be such that the degree of interference caused to other equipment is not higher than in today's systems.
RF Radiation Effects	UMTS shall be operative at RF emission power levels which are in line with the recommendations related to electromagnetic radiation.
Security	The UMTS radio interface should be able to accommodate at least the same level of protection as the GSM radio interface does.
Coexistence with other systems	The UMTS Terrestrial Radio Access should be capable to co-exist with other systems within the same or neighbouring band depending on systems and regulations
	Multimode implementation capabilities
	It should be possible to implement dual mode UMTS/GSM terminals cost effectively.

Annex 3: Support of speech by the UMTS access system

ETSI TC SMG Tdoc SMG 292/97

Meeting #21 Replaces Tdoc SMG 231/97

Paris, 10th - 14th February, 1997

Source: SMG11 Chairman

Subject: Support of speech by the UMTS access system

Following numerous debates in fora inside and outside of SMG, there now appears to be agreement (see meeting report of SMG#20) that UMTS should support a full range of services from narrowband (including speech) up to wideband (2Mbps) services. It is axiomatic that the types of data services to be supported on UMTS networks will be multifarious, ranging from simple low bit-rate bearer services (as available on Phase 1 GSM networks) to burst-mode packet-based wideband and multi-media services. However, this is not the case of speech applications which must be considered in a different way;

- unlike data services, the source data for speech is well characterised and fits within well understood limits of required coded bit rates.
- whereas the user bits of data services are, a priori, of unknown content or significance and must be protected to the same levels (hence average BER requirements definition), with coded speech, there are large variations in the sensitivity to errors of the coded speech bits and different levels of protection are needed.

This has implications for the transport and application hierarchy of the UMTS access system (UTRA). The current approach adopted for UTRA is to define a number of bearer services with specific throughputs at maximum BER and maximum delay. Applications use these bearers in a flexible manner (as from a tool-kit) to realise the required service applications. This may be well suited to data based services, but the implications of this approach for speech do not seem to have been studied in detail. Issues of concern:

- in order to meet a given speech quality, the bearer service would have to be selected according to the coded speech bits which are *most sensitive* to errors, as a result of which many bits would have excessive levels of protection. Thus an *average* BER of 10^{-3} is likely to give at best variable speech quality. This is less efficient than defining a channel coding scheme that is customised to the coded speech data to deliver the same quality of service.
- it is not clear how the approach would accommodate DTX or variable source-rate coding, both powerful techniques for increasing network capacity.
- it is not clear how the principles of the GSM AMR codec which include link adaptation would be accommodated. (They may be implicit in the transport layer of the UMTS bearer service but this needs to be determined and clarified.)

The risk therefore is that to deliver a speech service to a specified quality, the bearer service approach as it stands may lead to inefficient implementations, potentially of lower capacity than on GSM networks. This situation is not likely to be acceptable to operators or regulators.

It has also been suggested that, taking into account the dynamic aspects of both the source speech and the radio channel, speech should be based on packet access. This is an attractive concept in principle but whether this will work in practice will depend on many factors such as the packet size, maximum permitted delay and traffic volumes. This will need careful assessment.

Conclusion.

In developing the basic access system for UMTS, not only must the generic bearer services be defined, but it must be established that the major target applications for UMTS can be implemented using these bearer services in a spectrally efficient and cost effective manner. In this respect, it is important to recognise that the speech application differs from data services and the basic capabilities of UTRA should facilitate the efficient implementation of speech (with or without a single narrowband speech codec standard). These basic capabilities should include for example the support of variable source data rate, multi-level error protection and variable channel protection according to the instantaneous channel error rates.

The main points to be agreed for UMTS speech are that:

- speech will be an important [even if less important than data] service category (already agreed at SMG#20)
- a significant proportion of UMTS traffic will be narrowband speech, preferably coded using a common codec standard
- UMTS networks must be capable of implementing narrowband speech efficiently and *at least* to the same quality and capacity levels of GSM (including potentially the AMR codec). [More demanding targets may be considered.]

It is recommended that these requirements are reflected in the definition of UTRA and that SMG2 consults with SMG11 to ensure these requirements are met.

Annex 4: UMTS Radio Access Scheme Selection Criteria

SMG 187/97

Source: UMTS Forum WP04

UMTS Forum WG 4

Meeting No. 5

Kista 7 - 8 January 1997

Title: UMTS Radio Access Scheme Selection Criteria.

Essentials for Private and Business Applications.

The UMTS radio access scheme intends to support a wide range of mobile applications. Apart from public cellular systems, residential cordless telephones, private mobile systems and wireless local loop applications are in the scope of UMTS.

The requirements identified for this type of applications have to form a part of the selection procedure and criteria.

This document highlights essential requirements identified for private and business systems. It intends to give some guidance in the process of selection of the UMTS radio access scheme.

There are some fundamental differences between public and private systems. Customers buying a private cordless telephone or a private multicell system are free in their decision where to install this system. They expect the system to work properly as an independent system. A need to synchronise to adjacent systems or frequency planning will prevent this business to happen. Customers do not want to care about adjacent systems and they are not prepared to pay for the use of radio spectrum.

In terms of range, mobility and speed, the requirements to private systems may be restricted. A limitation of output power for example will keep interference to adjacent systems on a low level. A simpler cancellation method adjusted to the areas of operation of private systems would reduce complexity and finally reduce production cost.

To create a high volume market for terminals it is essential that a minimum set of capabilities of every terminal can be used in all systems.

- a) In conclusion the selection procedure and criteria for UMTS radio access scheme have to make sure that for private UMTS systems:
 - a) Multiple unsynchronised systems can successfully coexist in the same environment.
 - b) Base stations can be installed uncoordinated.
 - c) No frequency planning is needed.
 - d) No licence is needed to make use of the radio spectrum.
 - e) The radio access scheme is suitable for low cost applications where range, mobility and user speed may be limited.
 - f) A generic access profile can be defined, which guaranties
 - interoperability of terminals from different manufacturers
 - compliant UMTS terminals can be used in residential, business and public environment.

Annex 5: Procedure for the definition of the UMTS Terrestrial Radio Access

ETSI TC SMG Tdoc SMG 163/97
Meeting No 21
Paris, France
10-14 February 1997

Subject: Procedure for the definition of the UMTS Terrestrial Radio Access

Source: SMG2

Date: 14 January 1997

Introduction

This document provides a description of the procedure for deriving the UMTS Terrestrial Radio Access (UTRA). The primary goal of this procedure is to ensure a timely definition of the UMTS Terrestrial Radio Access so that operational UMTS systems can be in place within the time frame set by market demand. A further goal of this procedure is to make it possible to submit one and only one candidate for IMT-2000 to ITU as result of UMTS work performed by SMG.

This procedure, for deriving the UMTS Terrestrial Radio Access (UTRA), will strengthen the co-operative working method based on the well proven consensus based standardisation within SMG. The procedure will be open for contributions from all participants. It aims to maximise the benefit from the expertise and research of different players in all aspects of radio access technology. This should result in a UMTS Terrestrial Radio Access (UTRA) with an overall performance superior to that obtainable by a traditional "beauty contest" type of selection.

Finally, this open and co-operative procedure will assist in putting all participants into an equal position for the implementation of the derived standard and the subsequent entry into the UMTS market place.

Procedure for the definition of the UMTS Terrestrial Radio Access

The procedure for defining the UMTS Terrestrial Radio Access (UTRA) consists of an number of phases, where the change to the next phase is based on decisions made by consensus building.

Grouping phase

In the first phase of the UMTS Terrestrial Radio Access (UTRA) definition process, SMG2 will collect contributions and proposals on radio access technology for all or parts of the UMTS Terrestrial Radio Access. It is SMG2's task to study the different contribution both to verify their potential in relation to UMTS and also to find commonalities amongst the different proposals. The obtained knowledge about differences and commonalities amongst the proposals will be used to *define a limited number of UMTS Terrestrial Radio Access concepts, i.e. based on access technologies or combinations of them*. These defined concepts will then be further investigated and refined in the next phase. All proposals are allocated within the grouping structure.

In parallel with this work SMG2 will elaborate documentation of the high level requirements relevant for the definition of the UMTS Terrestrial Radio Access concept. Moreover, the two planned ETRs on overall requirements on the UMTS Terrestrial Radio Access and on evaluation procedures for the UMTS Terrestrial Radio Access (UMTS 04.01 and UMTS 04.02) are finalised in this phase.

At the end of this phase SMG is to approve the elaborated documentation and the *definition of a limited number of UMTS Terrestrial Radio Access concepts, i.e. based on access technologies or combinations of them*.

This approval is the first main milestone (M1) in the procedure for definition of the UMTS Terrestrial Radio Access.

Refinement and synthesis phase

In the second phase of the UMTS Terrestrial Radio Access (UTRA) definition process, SMG2 will refine the definition of each of the UMTS Terrestrial Radio Access concepts. This refinement will be driven by the contributions received from the

interested parties. In this phase SMG2 will also initiate a comparative evaluation of the defined UMTS Terrestrial Radio Access concepts in order to achieve the optimum UMTS Terrestrial Radio Access concept.

It is expected that SMG2 will create a subgroup for each of the defined concepts to perform the detailed evaluation and refinement. However, the SMG2 plenary will supervise the development of each of the concepts. In addition, the SMG2 plenary will be in charge of the comparative evaluation and consensus building around the evaluation results and conclusions. The organisation of the work within SMG2 shall be such that interested members can follow the detailed work in the various subgroups dealing with the different concepts.

Based on the ongoing comparative evaluation it is the task of SMG2 to eliminate by consensus those parts of the investigated UMTS Terrestrial Radio Access concepts which have lesser performance. This process in SMG2 shall end in elaboration of a proposal for *one UMTS Terrestrial Radio Access concept to be selected*.

At the end of this phase SMG is to approve the *selection of one UMTS Terrestrial Radio Access concept*.

This approval is the second main milestone (M2) in the procedure for definition of the UMTS Terrestrial Radio Access.

Definition phase

In the third phase of the UMTS Terrestrial Radio Access (UTRA) definition process, SMG2 will refine and optimise the selected UMTS Terrestrial Radio Access concept. This refinement and optimisation is open for contribution from all interested members and the actual process is driven by the contributions received.

The goal of this third phase is to conclude the definition of the UMTS Terrestrial Radio Access. The definition procedure is considered to be concluded by *definition of the key technical aspects of the UMTS Terrestrial Radio Access*. These key technical aspects are expected to include carrier bandwidth, modulation, channel coding, channel types, frame structure, access protocols, channel allocation and handover mechanisms, cell selection mechanism etc.

At the end of this phase SMG is to approve the *definition of the key technical aspects of the UMTS Terrestrial Radio Access*.

This approval is the third main milestone (M3) in the procedure for definition of the UMTS Terrestrial Radio Access.

Further work

After the approval of SMG, the defined UMTS Terrestrial Radio Access can be submitted to ITU as a candidate for IMT-2000.

After the completion of the definition UMTS Terrestrial Radio Access, the standardisation and specification phase will commence, and the detailed standards will be refined.

Annex 6: Proposed Time schedule for UMTS Terrestrial Radio Access definition

ETSI TC SMG Tdoc SMG 164/97
Meeting No 21
Paris, France
10-14 February 1997

Proposed Time schedule for UMTS Terrestrial Radio Access definition

Source: SMG2

Date: 14th January, 1997

Date	Responsible	Action
16-17 Dec 96	SMG2	Technical SMG2 workshop
SMG#21 10-14 Feb 97	SMG	Approval of the following documents: <ul style="list-style-type: none"> - Procedure for the definition of the UMTS terrestrial radio access - Time schedule for the definition of the UMTS terrestrial radio access Comments to the following document: <ul style="list-style-type: none"> - High level requirements relevant for the definition of the UMTS terrestrial radio access concept - draft version⁷⁷
SMG2#21 3-7 March 97	SMG2	Contributions and discussion of grouping of contributions/proposals into a limited number of UTRA concepts Refinement of the High level requirements relevant for the definition of the UMTS terrestrial radio access concept
SMG2#22 12-16 May 97	SMG2	Contributions and continuation of discussion of grouping of contributions/proposals into a limited number of UTRA concepts Refinement of the High level requirements relevant for the definition of the UMTS terrestrial radio access concept (if need). Elaboration of proposals for milestones M1 (as defined below)
SMG#22 9-13 June 97	SMG	Approval of the following document: <ul style="list-style-type: none"> - High level requirements relevant for the selection of the UMTS terrestrial radio access concept - Approval of UMTS 04.01 and 04.02 Approval of the definition of a limited number of UTRA concepts (milestone M1)
SMG2#23 22 - 26		Work to be progressed

⁷⁷ The document on "High level requirements relevant for the selection of the UMTS terrestrial radio access concept" is to be elaborated by SMG2 taking into account comments from SMG, SMG1, MoU 3GIG and the UMTS Forum.

Date	Responsible	Action
September 97		
SMG#23 (13-17 Oct. 97)	SMG	Progress report from SMG2 to SMG
SMG2#24 1-5 December 97	SMG2	Finalisation of proposal for M2 to SMG#24
SMG#24 15-19 December 97	SMG	Approval of M2: Selection of one UMTS terrestrial radio access concept
SMG2#25 Q1 98		Work to be progressed
SMG#25 16-20 March 98		Progress report from SMG2 to SMG
SMG2#26 Q2 98		Work to be progressed
SMG#26 22-26 June 98	SMG	Approval of M3: Specification of key technical aspects of the UMTS terrestrial radio access
Summer 98		Submission of candidate to ITU

Milestones:

- M1 Definition of a limited number of UMTS Terrestrial Radio Access concepts, i.e. based on access technologies or combinations of them.
- M2 Selection of one UMTS Terrestrial Radio Access concept
- M3 Definition of key technical aspects of the UMTS terrestrial radio access (including carrier bandwidth, modulation, channel coding, channel types, frame structure, access protocols, channel allocation and handover mechanisms, cell selection mechanisms etc.)

Annex 7:

Liaison statement on principles for hardware validations during the definition of the UMTS Terrestrial Radio Access (UTRA)

ETSI TC SMG Tdoc SMG 165/97
Meeting No 21
Paris, France
10-14 February 1997

Source: SMG 2

To: SMG

Date: 14 January 1997

Subject: Liaison statement on principles for hardware validations during the definition of the UMTS Terrestrial Radio Access (UTRA)

The purpose with the document is to clarify the overall principles concerning possible hardware validations during the definitions of UTRA. The document is connected to the "Procedure for the definition of the UMTS terrestrial Radio Access".

A common point of view in SMG 2 is that the need and usage of a comprehensive hardware test-bed, in order to verify different UMTS radio concepts during the definition and selection of the UTRA, would be very limited. The background to the statement is that:

- simulation tools in combinations with the increased computer capacity make the simulations more reliable e.g. compared to the evaluation procedure of GSM.
- the basic functionality of a majority of the proposed techniques, that is applicable to validate in a test-bed, is already verified in other test-beds.
- more interesting evaluation topics, e.g. the performance in a heavy loaded system, require an unrealistic amount of complicated hardware test-bed units and an extensive amount of time-consuming measurements
- in agreement to the proposed procedure for deriving the UTRA, no traditional "beauty contest" type of selection will be accomplished. Instead SMG2 plans to create subgroups, for each of the appropriate concepts defined by grouping of proposals. Performed evaluations, validations and the successive elimination of less applicable technologies, then is based on consensus building.

However, during the procedure to define the UTRA, it is important to identify possible topics for each subgroups, that require to be validated in a *condensed* hardware test-bed. As the procedure should be considered as "contribution driven" it is expected that the proponents would perform the necessary validations. In order to accomplish hardware evaluations before the milestone M2 (the selection of one UMTS terrestrial radio access concept) The identification of critical topics need to be performed at the very beginning, preferably before milestone M1.

The purpose with the hardware validation is not only to create consensus and confidence within SMG2 it also aim to assure the overall feasibility to implement the UTRA as an important part of the fulfilment of the standardisation. This imply that the continuing evaluation of the UTRA after milestone M3 (Specification of key technical aspects of UTRA) may require more extensive hardware validations.

Conclusions

Comprehensive hardware test-beds will not be used during the selection and definition procedure of the UMTS Terrestrial Radio Access (UTRA) as described in "Procedure for the definition of the UMTS Terrestrial Radio Access".

Further on, SMG2 believes that a complete hardware validation of the fully defined UTRA would be a substantial undertaking, which would require a substantial amount of forward planning.

Annex 9: Consideration of a Global pilot mechanism

ETSI/TC/SMG#23 PLENARY

Tdoc SMG 879/97

13 - 17 October 1997

(replacing Tdoc 557/97)

Budapest

To: SMG# 22 Plenary

From: Ad Hoc Group

CONSIDERATION OF A GLOBAL PILOT MECHANISM.

1 Issue: SMG2 sent a liaison statement to SMG, Tdoc 337/97, part of which addressed the 'Global Pilot Mechanism'. An ad-hoc sub-group of the Plenary, led by S Cooke, UK DTI, was asked to further address this issue and to consider the following;

1.1 What guidance to give SMG2 on this issue to enable SMG2 to proceed with the selection of the UMTS radio interface.

1.2 What advice to give to the CEPT ERC in its preparations for WRC and ITU-R Task Group 8/1 IMT-2000 activities.

2 Background: The following summarises the two main issues;

2.1 SMG2 has the responsibility to define radio interfaces that comply with certain defined requirements one of which relates to global roaming capabilities, One possible method of meeting this requirement is by use of a Global Pilot Channel which broadcasts details of available radio channels and their parameters, SMG2 wish to be advised by SMG whether this should be independently of the UMTS radio interface, perhaps as some form of overlay mechanism.

This aspect of the issue was considered entirely as an internal SMG matter.

2.2 The CEPT ERC is considering proposals for agenda items for WRC-99. One proposed agenda item concerns UMTS and whether a frequency should be identified for a global pilot channel, for example to meet the above global roaming requirement. The proposed agenda items for WRC-99 will be presented at WRC-97 and the ITU-R Task Group 8/1 may also consider this concept at its meeting in September 1997. It was therefore considered important that SMG considers this aspect of global roaming in preparation for these activities.

This aspect was considered to be an external matter, but one in which SMG, together with others involved with UMTS, should develop an opinion.

3 Recommendation of the Ad-Hoc Group:

The Ad-Hoc Group recommends that ETSI SMG Plenary supports the following;

3.1 SMG2 need not consider the global roaming mechanism (e.g. a pilot channel) in the selection of the UMTS radio interface. Any global pilot channel may be considered to work independent of the UTRA and if required may be implemented as an overlay mechanism.

3.2 SMG should not, at the present time, propose the concept of the global pilot mechanism, due to the uncertainties of the direction and characteristics of all IMT-2000 radio interfaces. However, if this is raised in other fora such as the ITU, and SMG's view is sought, then the following characteristics are requirements of a global pilot mechanism;

- Simplicity.
- Low spectrum resource.
- Broadcast only.
- To only provide information which is absolutely necessary, such as the radio access parameters the frequency raster, etc. at which to initiate communication.
- Its use shall be optional

- Its use shall not preclude other mechanisms (e.g. manual input or self-scanning functions in the mobile terminal) which may be available to facilitate global roaming.
- It should not necessarily be a fixed frequency.

This is only initial view from SMG and it is recognised that more rigorous evaluation of any proposals would need to be made as soon as more complete information on IMT 2000 radio interfaces becomes available. Other fora such as the UMTS Forum and CEPT ERC may also wish to comment on this concept and its implementation.

Annex 10: Agreement on Common Working Procedures between ARIB and SMG

Status at SMG: Approved by SMG 13 - 17 October 1997 (SMG#23)

Status at ARIB: To be presented to Standard Sub-Committee for approval October 1997

1 ARIB and SMG agree on mutual participation in their meetings on IMT-2000 Radio Access definition.

For SMG, this includes:

- concept groups meetings of SMG2
- SMG2 Ad-hocs on UMTS
- SMG2 plenaries
- SMG plenaries

For ARIB, this includes:

- Co-ordination Group in Standard Sub-Committee
- Relevant working groups for specifications

Participation includes the right to speak and contribute.

Meeting schedules, invitations, agendas, reports and document lists will be exchanged in time between Standard Sub-Committee ARIB and PT SMG for distribution to their members. Further documents will be made available on request by these two institutions.

Due to the areas of responsibilities within two groups, the initial work will focus on layer 1 issues.

2 ARIB and SMG intend to organise multi-lateral meetings between ARIB, SMG and the relevant American standards organisations, starting in early February 1998.

Objectives of these meetings are to establish the necessary discussion and information exchange to enable the standards organisations to keep the number of IMT-2000 RANs to a minimum and to maximise commonalities between them. In addition, ARIB aims to convergence to one common global RAN. The work should take into account the ITU-R time schedules for IMT-2000.

ARIB and SMG intend to keep the current ITU-R time schedule.

NOTE: ARIB will discuss this intention with TIA and SMG with T1P1.

Annex 11: Agreed proceeding for the SMG - TTC network aspects working group:

Scope of activity starting in October meeting shall be:

- Identify components in the view of - global - roaming and subscriber/mobility management.
- Study the feasibility for the radio access independent A-Interface (Iu-Interface)
- Examine the SIM (UIM) as a component
- Examine potential components in L3 of the radio interface.
- Discuss common conceptual understanding
- Identify further components/sub-components

The group shall report to TTC and SMG. This includes a workplan.

Basis is a phased evolution of the IMT2000 Core Networks possibly with independent speed on particular features/functions, but with an agreed schedule of core features/functions.

Updates of the picture "Phased Approach" (slide5) and the "Milestone/Workplan" (slide9) are needed to reflect this.

Components:

Three degrees of harmonisation are identified:

- acceptance in ITU
- harmonisation between Standardisation organisations
- independent development in standardisation organisations

The meeting is entitled to change and revise details of the scope, but has to report this back to SMG and TTC.

Annex 12: Future Organisation for GSM and UMTS Standardisation

ETSI SMG Plenary#24

SMG TDoc 1154/97

15 - 19 December 1997

(replacing TDoc 1142/97)

Madrid, Spain

Title: Future Organisation for GSM and UMTS Standardisation

Source: SMG

Date: 19 December 1997

1 Guidance for Exploratory Mission

ETSI SMG aims at a smooth and efficient standardisation process for the evolution of GSM and towards UMTS. In order to facilitate this it is indispensable to ensure

the production of an open and complete system standard for UMTS as a member of the IMT 2000 family,

the continuous evolution and maintenance of GSM (900, 1800 and 1900),

a productive relationship to other standardisation bodies considering UMTS work issues.

For this purpose the following is to be considered:

fast access to actual standardisation results for all participants,

full participation of all interested parties world-wide and

equal rights for all participants.

Also it is necessary

to guarantee an efficient organisation of the standardisation work,

to avoid parallel and possibly conflicting work in different standardisation organisations,

to avoid unnecessary complex work sharing between standardisation organisations and unnecessary hierarchical decision processes.

In addition,

regulatory requirements need to be addressed

as well as terminal certification requirements.

The working structure needs to take into account those aspects, and respective documents should be produced.

2 Mandate for Exploratory Missions

SMG grants a mandate for exploratory missions to the SMG Chairman to sound and identify elements for a solution meeting the targets mentioned above, in the framework of an ETSI partnership project, which would produce GSM and UMTS specifications also for ETSI (details on ETSI Partnership Projects: see annex).

Ideally it should be aimed at one, and only one, joint working structure among all interested bodies, avoiding parallel work and overhead co-ordination and saving both time and money. Current budget allocations for ETSI SMG should be considered as an asset for this possible joint working structure.

The SMG Chairman should report to SMG#25 and propose a way forward.

It is expected that the SMG chairman will contact

in the U.S.: ANSI T1P1, T1

in Asia: MPTs, standardisation bodies

in Europe: ETSI, European Commission, ECTEL/TMS

GSM MoU Association

UMTS Forum

The SMG Chairman will seek support for the mission by the two SMG Vice Chairmen. They are supported by the PT SMG leader.

Annex: Rules for ETSI Partnership Projects

Annex

Quotation from: ETSI Rules of Procedure, 19 April 1996

Article 6: Technical Organization

6.1 The Institute shall have a Technical Organization, which provides a structure in which technical experts can work together efficiently and effectively. The work of the Technical Organization shall be structured to provide for market driven technologically oriented activities in Technical Committees and ETSI Projects and in ETSI Partnership Projects. Specialist Task Forces may be established to fulfil specific tasks, of a limited duration, in support of the standardization activities.

Quotation from: ETSI Technical Working Procedures, 04 June 1997

1.1.3 Characteristics of an ETSI Partnership Project

An ETSI Partnership Project is an activity established when there is a need to co-operate with an external body and where such co-operation cannot be accommodated within an ETSI Project or Technical Committee.

An ETSI Partnership Project:

is established on the basis of a market sector requirement rather than a basic technology, and has a limited duration;

has the market sector requirements for the project result described in the Project Requirements Definition. The project has its own business development activity to reconfirm, continuously, the market need for its planned results, or if needed, to suggest refinements to the Project Requirements Definition;

has its own project and programme management and timed deliverables;

is responsible for defining, creating and stopping detailed *ETSI work items* (as defined in subclause 1.6), within its scope, required to fulfil its Terms of Reference);

is responsible for the approval of its own deliverables, i.e. the project output, including their validation (i.e. ensuring that the deliverable can be fully implemented, providing the intended level of functionality and performance at minimum cost, as defined in the Project Requirements Definition);

comprises participation by representatives of ETSI full and associate members as well as significant co-operation with, and participation by, external bodies;

has working procedures, policies and support from the ETSI Secretariat, defined in an agreement or contract between ETSI and the partners, which may vary from the procedures laid down in these Technical Working Procedures;

should normally produce appropriate *ETSI deliverables*, but has the option to decide on the nature of its deliverables (and thus on the nature of their approval/publication);

has a defined legal status with respect to liability and copyright;

should manage its own financial affairs;

may subcontract work of a generic nature to a Technical Committee having the appropriate competence. Relevant work should be progressed by the Technical Committee to the required project time scales;

reports to the General Assembly on work progress when requested.

Annex 13: SMG policy on IMT-2000 Family Concept

Title: IMT 2000 Family of Systems Concept

Source: SMG#24

Date: 18December 97

Purpose: SMG internal policy paper

Status: Approved

1 IMT 2000 Family of Systems (IFS) Concept

ITU SG11 accepted the IMT 2000 Family of Systems (IFS) concept in principle. This means that IMT 2000 will have a number of different systems as members. This paper describes SMG's common understanding of the IFS concept and identifies concepts to realise global roaming within the IMT 2000 Family of Systems. It proposes also some terminology.

2 Emerging IMT 2000 Family of Systems (IFS) Members

Definition

The Family Concept is the definition of a set of standardised systems with a certain amount of commonality and interoperability, that are recommended by ITU as part of the IMT-2000 family, meeting the IMT-2000 requirements. In practice, this will consist of a family of radio and a family of core network technologies.

Furthermore an essential minimum set of membership criteria should be sufficient to distinguish IMT 2000 systems from second generation systems. On the other hand the criteria should be open to accommodate all emerging present or future IFS members.

Further detailed lists of objectives can be found in one or more of the following:

ETSI

ETSI SMG

ITU-T

ITU-R

2.2 Possible IFS members

The following list is present visible systems which can be considered as the members of the IMT 2000 family of systems:

UTRA + GSM-UMTS CN

UTRA + ISDN derived CN

US TDMA evolution of IS 136 + IS41 + WIN

CDMA-One evolution of IS 95 + IS41 + WIN

Japanese IMT 2000 air interface proposal + GSM-UMTS CN

3 Roaming Concept

3.1 Two Tier Roaming Concept

Roaming in this paper addresses roaming between networks (inter network roaming). This can be roaming between regional networks within a country or between national/regional networks in different countries.

It must be distinguished whether the two networks involved in roaming (the home network and the visited network) belong to the same IMT 2000 system or two different systems (intra system roaming and inter system roaming).

IMT 2000 global roaming encompasses both inter system and intra system roaming. It should therefore be called a two tier roaming concept.

3.2 Intra System Roaming

The intra system roaming uses the architecture and protocols from the regional standards body.

3.3 Inter System Roaming

The inter system roaming is based on the following architecture:

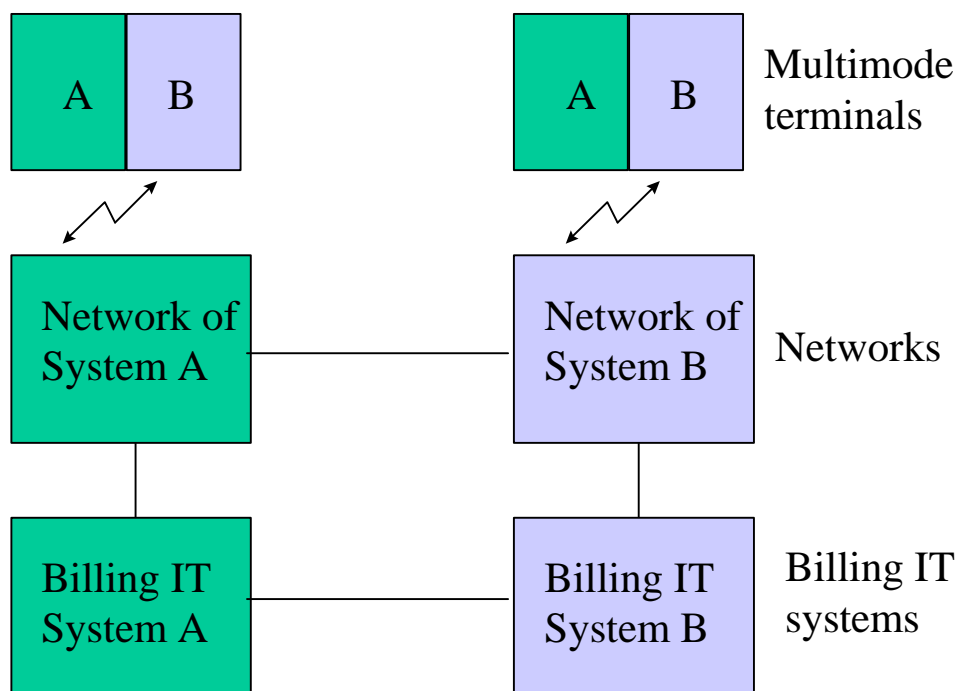

Figure 1: Architecture for Inter System Roaming

NOTE: An interworking function may be defined by, for example, protocol translators or implementation of two protocols in one entity.

4 Enabling Inter System Roaming

The framework architecture and the principles as described above should be standardised in ITU SG11.

The regional standardisation organisations, who standardise IFS members should enter into discussions to seek international commonalities to enable Inter System Roaming. This could include commonalities in subscriber identities, service definition, authentication, radio interface, network aspects and accounting protocols. The target of these activities should be simplification of multimode terminals and simplification of system interfaces.

The interested parties representing the various IFS members should agree on requirements for Inter System Roaming to guide the standardisation work.

History

Document history		
Date	Status	Comment
June 97	3.0.0	Approved by SMG#22
July 1997	draft 3.0.1	draft, some editorial changes by UMTS programme manager
October 1997	3.1.0	changes related to agreed positions at SMG#22 approved by SMG#23
December 1997	3.2.0	approved by SMG#24, changes related to agreed positions at SMG#23 and input from SMG1 for chapter 9.1
June 1998	3.3.0	approved by SMG#26 changes related to agreed positions at SMG#24, SMG#24bis, SMG#25 and changes requested by France Telecom
November 1998	3.4.0	Approved by E-mail in November 1998, It contains decisions introduced by CR related to SMG26., Helsinki meeting. Decisions related to SMG27 Praha will be introduced in the next version of UMTS Baseline document
December 1998	Draft 3.5.0	To be approved by E-mail. It contains decisions of SMG27 and some Alcatel's proposals for improvement of the document
January 1999	Draft 3.5.1	Revision marks accepted in version 3.5.0 which was approved by e-mail after SMG#27. (Includes minor editorial corrections).