

CR-Form-v7

## CHANGE REQUEST

⌘ **23.846 CR 001** ⌘ rev **-** ⌘ Current version: **6.0.0** ⌘

For **HELP** on using this form, see bottom of this page or look at the pop-up text over the ⌘ symbols.

**Proposed change affects:** UICC apps  ME  Radio Access Network  Core Network

<b>Title:</b>	⌘ Alignment of content of 23.846 version 6 to 23.846 v.2.0.0		
<b>Source:</b>	⌘ MCC		
<b>Work item code:</b>	⌘ MBMS	<b>Date:</b>	⌘ 11/12/2002
<b>Category:</b>	⌘ <b>F</b>	<b>Release:</b>	⌘ Rel-6
	Use <u>one</u> of the following categories: <b>F</b> (correction) <b>A</b> (corresponds to a correction in an earlier release) <b>B</b> (addition of feature), <b>C</b> (functional modification of feature) <b>D</b> (editorial modification) Detailed explanations of the above categories can be found in 3GPP <a href="#">TR 21.900</a> .		Use <u>one</u> of the following releases: 2 (GSM Phase 2) R96 (Release 1996) R97 (Release 1997) R98 (Release 1998) R99 (Release 1999) Rel-4 (Release 4) Rel-5 (Release 5) Rel-6 (Release 6)

<b>Reason for change:</b>	⌘ Version 2.0.0 of TR 23.846 was presented and approved at SA#17 in September 2002 (tdoc SP-020535). The content of version 6.0.0 available on the 3GPP server shortly after SA#17 does not correspond to the one of SP-020535. This CR aligns the content of 23.846 v.6.0.0 to the one of v.2.0.0, so that v.6.1.0 matches what was approved in SP-020535.
<b>Summary of change:</b>	⌘ Alignment of content of 23.846 v.6.0.0 to 23.846 v.2.0.0.
<b>Consequences if not approved:</b>	⌘ TR 23.846 version 6 would continue to contain an unagreed text.

<b>Clauses affected:</b>	⌘ All										
<b>Other specs affected:</b>	<table border="1" style="display: inline-table; border-collapse: collapse;"> <tr> <td style="width: 20px; text-align: center;">Y</td> <td style="width: 20px; text-align: center;">N</td> </tr> <tr> <td style="text-align: center;"><input type="checkbox"/></td> <td style="text-align: center;"><input checked="" type="checkbox"/></td> </tr> <tr> <td style="text-align: center;"><input type="checkbox"/></td> <td style="text-align: center;"><input checked="" type="checkbox"/></td> </tr> <tr> <td style="text-align: center;"><input type="checkbox"/></td> <td style="text-align: center;"><input checked="" type="checkbox"/></td> </tr> </table> Other core specifications ⌘ Test specifications ⌘ O&M Specifications ⌘	Y	N	<input type="checkbox"/>	<input checked="" type="checkbox"/>	<input type="checkbox"/>	<input checked="" type="checkbox"/>	<input type="checkbox"/>	<input checked="" type="checkbox"/>		
Y	N										
<input type="checkbox"/>	<input checked="" type="checkbox"/>										
<input type="checkbox"/>	<input checked="" type="checkbox"/>										
<input type="checkbox"/>	<input checked="" type="checkbox"/>										
<b>Other comments:</b>	⌘ As recommended during SP#18, the CR shows a deletion of the complete content of 23.846 v.6.0.0 to replace it by the content of 23.846 v.2.0.0.										

## ~~1—Scope~~

~~The present document discusses architectural issues and describes functionalities required for the Multimedia Broadcast/Multicast Service. MBMS requirements are discussed in [2] and it is the intention of this document to present one or more alternatives to achieving the required functionality within 3GPP networks.~~

## ~~2—References~~

~~The following documents contain provisions which, through reference in this text, constitute provisions of the present document.~~

~~—References are either specific (identified by date of publication, edition number, version number, etc.) or non-specific.~~

~~—For a specific reference, subsequent revisions do not apply.~~

~~—For a non-specific reference, the latest version applies. In the case of a reference to a 3GPP document (including a GSM document), a non-specific reference implicitly refers to the latest version of that document *in the same Release as the present document*.~~

~~[1] 3GPP TR 21.905: "3G Vocabulary".~~

~~[2] 3GPP TS 22.146: "Multimedia Broadcast/Multicast Service; Stage 1".~~

~~[3] IETF RFC 2710 (1999): "Multicast Listener Discovery (MLD) for IPv6"~~

~~[4] 3GPP TS 23.107: "QoS Concept and Architecture"~~

## ~~3—Definitions and abbreviations~~

### ~~3.1 Definitions~~

~~For the purposes of the present document, the terms and definitions given in [1] and the following apply.~~

~~**MBMS broadcast activation:** The process which enables the data reception from a specific broadcast mode MBMS on a UE.~~

~~**MBMS multicast activation:** The process which enables a UE to receive data from a specific MBMS multicast. Thereby the user joins a specific multicast group. The activation may be performed by the user and it may be performed inherently for subscribed multicast services.~~

~~**MBMS Notification:** The mechanism which informs the UEs about a forthcoming (and potentially an ongoing) data transfer from a specific MBMS service~~

### ~~3.2 Abbreviations~~

~~For the purposes of the present document, the following abbreviations apply:~~

~~BM-SC—Broadcast Multicast Service Centre~~

~~IGMP—Internet Group Management Protocol~~

~~MLD—Multicast Listener Discovery~~

~~MBMS—Multimedia Broadcast/Multicast Service~~

~~Other abbreviations used in the present document are listed in 3GPP TR 21.905 [1].~~

## ~~4—Introduction~~

~~The MBMS [2] is a point to multipoint service in which data is transmitted from a single source entity to multiple users. Transmitting the same data to multiple users allows network resources to be shared.~~

~~The MBMS offers two modes:~~

~~—**Broadcast Mode**~~

## ~~—Multicast Mode~~

### ~~5—High Level Functionality~~

#### ~~5.1Architecture Principles~~

~~In developing and evaluating different architectural options for MBMS, the following principles should be taken as general architectural guidelines that should be followed:~~

~~1.MBMS architecture shall enable the efficient usage of radio network and core network resources, with the main focus on the radio interface efficiency. Specifically, multiple users should be able to share common resources when receiving identical traffic.~~

~~2.The MBMS architecture shall support common features for MBMS multicast and broadcast modes, e.g. both modes shall preferably use the same low layer bearer for data transport over the radio interface.~~

~~3.MBMS architecture shall support external data sources in both modes. MBMS shall support both IP multicast and IP unicast sources.~~

~~4.MBMS architecture should re-use, to the extent possible, existing 3GPP network components and protocol elements thus minimizing necessary changes to existing infrastructure and providing a solution based on well known concepts.~~

~~5.MBMS shall be a point to multipoint bearer service for IP packets in the PS domain.~~

~~6.MBMS shall be interoperable with IETF IP Multicast.~~

~~7.MBMS shall support IETF IP Multicast addressing.~~

~~8.It shall be possible for UEs to receive MBMS when the terminal is attached.~~

~~9.It shall be possible for UEs to receive MBMS data in parallel to other services and signalling (e.g. paging, voice call).~~

~~10.MBMS shall support different quality of service levels. The mechanisms for this are for further study, one example is repetitions to all users.~~

~~11.MBMS service areas shall be defined per individual service with a per cell granularity.~~

~~12.MBMS is not supported in the CS domain.~~

~~13.When the UE is already receiving data of an MBMS service, it shall be possible for the UE to be notified about a forthcoming and potentially about an ongoing data transfer from other MBMS services.~~

~~14.Charging data shall be provided per subscriber for MBMS multicast mode.~~

~~15.The MBMS bearer service concept should contain the decision making process for selection of point to point or point to multipoint configurations.~~

~~16.The architecture should be able to provide home MBMS multicast services to users when roaming outside their home network as subject to interoperator agreements.~~

~~17.MBMS should be designed to minimise power consumption within the mobile station.~~

~~18.Applications shall be tolerant to packet loss and duplication caused by e.g. UE mobility or transmission loss.~~

~~19.“The backwards compatibility of the MBMS service to the R99 IP multicast delivery mechanism shall be considered. Interworking possibilities between MBMS capable network elements and non MBMS capable network elements (e.g. interworking with R99 IP Multicast service GGSNs) shall be described.~~

#### ~~5.2Architectural Overview~~

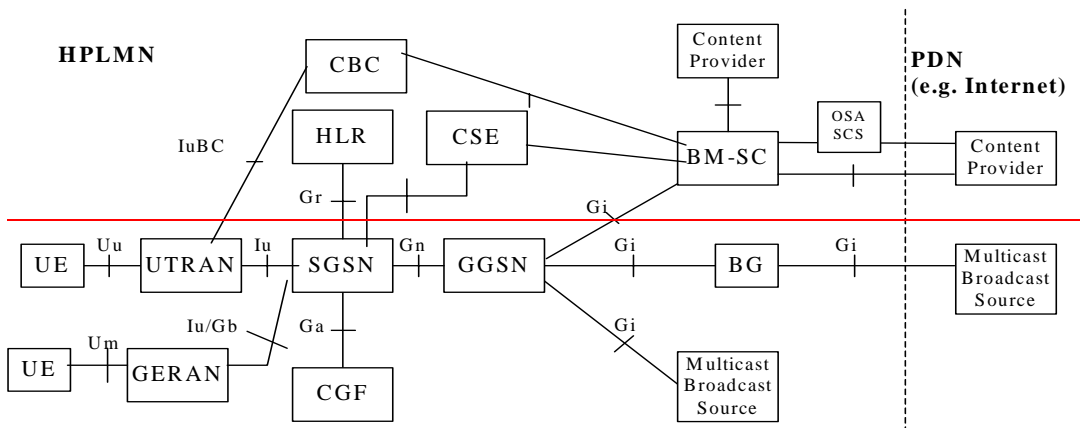

Figure 1. MBMS Architecture

In the MBMS architecture the SGSN performs user individual service control functions and the SGSN concentrates all individual users of the same MBMS service into a single MBMS service. The SGSN maintains a single connection with the source of the MBMS data. The SGSN duplicates the packets received from the GGSN for forwarding to each RNC involved in provision of a specific MBMS service.

The SGSN may use CAMEL to handle pre-paid services, e.g. credit checking for on-line charging.

The GGSN terminates the MBMS GTP tunnels from the SGSN and links these tunnels via IP multicast with the MBMS data source. The GGSN duplicates the packets received from the MBMS data source for forwarding to each SGSN to which a GTP tunnel is established for a specific MBMS service.

The BM-SC is an MBMS data source. MBMS data may be scheduled in the BM-SC, e.g. for transmission to the user every hour. It offers interfaces over that content provider can request data delivery to users. The BM-SC may authorise and charge content provider. The BM-SC might use OSA-SCS to interact with third parties.

The Cell Broadcast Centre (CBC) may be used to announce MBMS services to the users. How this is accomplished is FFS.

The architecture allows for other MBMS broadcast/multicast data sources. Internal data sources may directly provide their data. Data delivery by external sources is controlled by Border Gateways (BG) which may allow for example data from single addresses and ports to pass into the PLMN for delivery by an MBMS service.

The architecture assumes the use of IP multicast at the reference point Gi. The MBMS data source has only one connection to the IP backbone. The reference point from the content provider to the BM-SC is not standardised. It might become to complex or to restrictive for service creation. For example, this may be a reference point between the BM-SC and an authoring system, or the authoring functionality may be distributed between both entities.

The same architecture provides MBMS broadcast services mainly by using the transport functions. The user individual SGSN functions are not required. Instead each individual broadcast service is configured in the SGSN.

Note: For the terminal split case, MBMS shall be able to interoperate with an IP multicast client software on the TE. The mechanism for this interoperability is FFS.

### 5.3 MBMS Reference Points

Description of MBMS interaction with other entities within the network (e.g. User, VASP, Charging DB, Other?)

### 5.4 High Level Functions

Multimedia Broadcast/Multicast Service is associated with several logical functions that should be provided by the network:

#### 5.4.1 Authentication and Authorization

##### 5.4.1.1 Content Provider Authentication and Authorization

—MBMS should be able to identify and authenticate the content provider prior to receiving control or data from it.

~~—A content provider may request to provide a multicast or broadcast service using MBMS possibly stating desired QoS, geographical areas and other service related parameters. MBMS shall be able to authorize this service provision with the requested parameters prior to service initiation.~~

#### ~~5.4.1.2 User Authentication and Authorization~~

~~—MBMS shall be able to authenticate and authorize users before joining to multicast groups (i.e. receive MBMS multicast services).~~

#### ~~5.4.2 Efficient Routing and Resource Usage~~

~~—The MBMS shall be able to efficiently route multicast and broadcast over the radio interface and within the radio network. Efficient routing within the core network is desired as well.~~

~~—In Multicast mode, MBMS should support multicast resource allocation where by data transmission to a multicast group is carried out in certain cell only if multicast group members are to be found in that cell.~~

~~—Hierarchically structured networks can provide coverage for a given location using multiple carrying frequencies or multiple cells of varying sizes. Provisioning and efficient delivery of MBMS services within hierarchical network architectures should be considered.~~

#### ~~5.4.3 Mobility Management and Service Continuity~~

~~—MBMS shall support service continuity when moving from cell to cell within the multicast/broadcast area.~~

~~NOTE: Loss of data may occur during this process.~~

~~—MBMS should enable roaming users to receive both home and local multicast services. Roaming users should be able to receive local broadcast services as well.~~

#### ~~5.4.4 Service Initiation and Termination~~

~~—The UE shall be able to enable and disable broadcast service reception.~~

~~—The UE shall be able to join and leave multicast groups. Roaming users should be able to join and leave multicast groups in the home or visited network.~~

#### ~~5.4.5 Charging~~

~~MBMS shall collect charging information about the delivery of MBMS broadcast or multicast data that are provided by content or service providers (e.g. 3<sup>rd</sup> parties). This shall enable billing of broadcast and multicast content or service providers. This charging information may include duration of service usage, volume of MBMS data, MBMS service area.~~

~~MBMS shall collect charging information about the usage of MBMS multicast services by individual users/receivers. This charging information may include duration of service usage, volume of MBMS data, time when joining or leaving a multicast group.~~

#### ~~5.4.6 Security~~

~~—To prevent unauthorized reception of multicast data, multicast transmission may be secured.~~

~~—To prevent injection of malicious content into the network MBMS should be able to authenticate the content provider and verify the integrity of the data received from the content provider.~~

~~—See also clause “Authentication and Authorization“~~

#### ~~5.4.7 Addressing~~

#### ~~5.4.8 Roaming~~

#### ~~5.4.9 MBMS Service Provision Phases~~

##### ~~5.4.9.1 MBMS broadcast service provision phases~~

~~An example for the phases of MBMS broadcast service provision is described in the figure below.~~

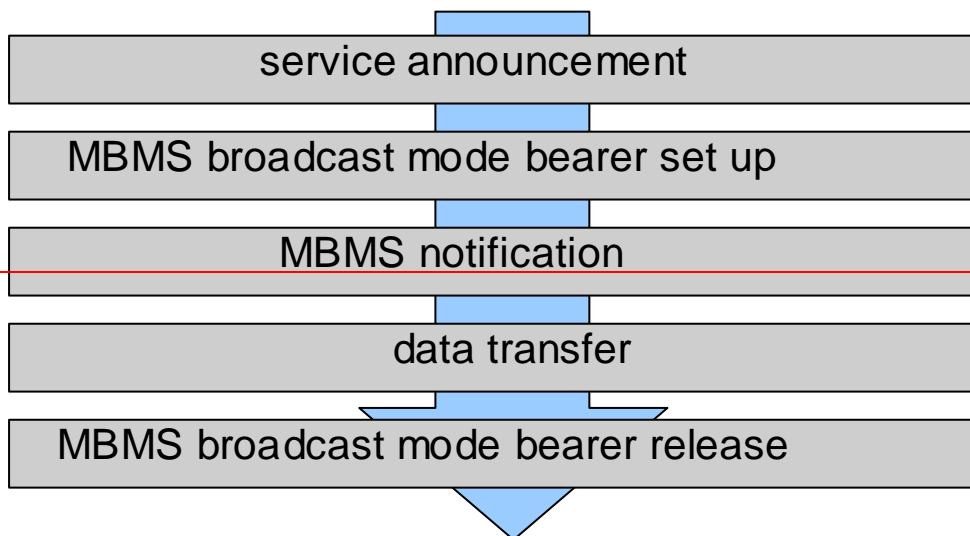

Fig. 2: Phases of MBMS broadcast service provision

**Service announcement** informs UEs about forthcoming services.

**MBMS broadcast mode bearer set up** establishes the network resources for MBMS data transfer in the broadcast area.

**MBMS notification** informs the UEs about forthcoming (and potentially about ongoing) broadcast data transfer.

**Data transfer** is the phase when MBMS data are transferred to the UEs.

**MBMS broadcast mode bearer release** releases the network resources for MBMS data transfer, e.g. when no more MBMS data have to be transferred.

The sequence of phases may repeat, e.g. depending on the need to transfer data. Also service announcement as well as MBMS notification may run in parallel to other phases to inform UEs which have do not yet receive the related service.

#### 5.4.9.2 MBMS multicast service provision phases

An example for the phases of MBMS multicast service provision is described in the figure below.

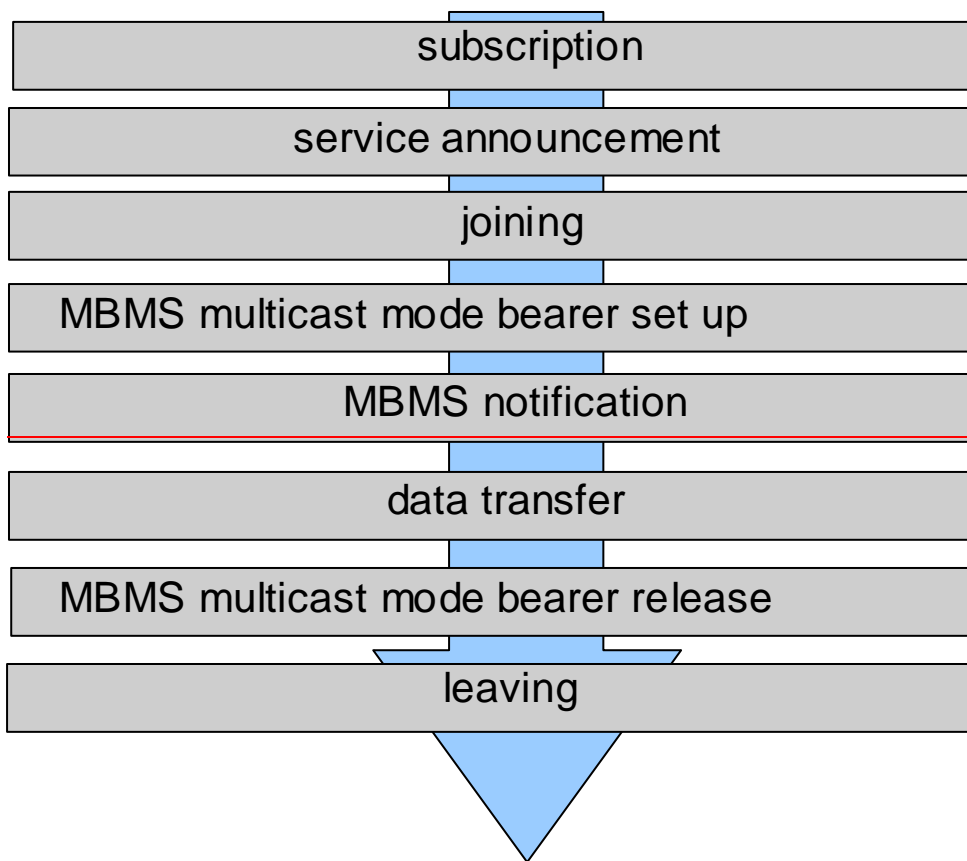

Fig. 3 Phases of MBMS multicast service provision

**Subscription** establishes the relationship between the user and the service provider, which allows the user to receive the related MBMS multicast service

**Service announcement** informs UEs about forthcoming services.

**Joining** (MBMS multicast activation) is the process by which a subscriber joins (becomes a member) a multicast group, i.e. the user indicates to the network that he/she is willing to receive Multicast mode data of a specific service.

**MBMS multicast mode bearer set up** establishes the network resources for MBMS data transfer in the multicast area.

**MBMS notification** informs the UEs about forthcoming (and potentially about ongoing) multicast data transfer.

**Data transfer** is the phase when MBMS data are transferred to the UEs.

**MBMS broadcast mode bearer release** releases the network resources for MBMS data transfer, e.g. when no more MBMS data have to be transferred.

**Leaving** (MBMS multicast deactivation) is the process by which a subscriber leaves (stops being a member) a multicast group, i.e. the user wants to receive no longer Multicast mode data of a specific service.

The phases subscription, joining and leaving are performed individually per users. The other phases are performed for a service, i.e. for all users interested in the related service. The sequence of phases may repeat, e.g. depending on the need to transfer data. Also subscription, joining, leaving, service announcement as well as MBMS notification may run in parallel to other phases.

6 Functions and Entities

More detailed description of functions, discussion of options for functions, description of network entities.

6.1 UTRAN/GERAN Functionality

~~—The UTRAN shall deliver the MBMS service over at least the broadcast or multicast service area. The served area might be larger than the multicast or broadcast area, e.g. when the multicast or broadcast area does not exactly map onto cell or LA borders of the UTRAN.~~

~~—The UTRAN may establish point to multipoint channels at the air interface without any required uplink radio signaling from the UE(s) for broadcast mode~~

#### ~~6.1.1 Broadcast Mode~~

#### ~~6.1.2 Multicast Mode~~

~~The radio access network (UTRAN/GERAN) shall provide the following functionality for efficient support of MBMS~~

~~—responsible for establishment of point to multipoint or point to point channels on the air interface to support MBMS.~~

~~—capable of routing MBMS traffic over either a point to multipoint channel or over a point to point channel.~~

~~—capable of discovering the number of MBMS users within a cell~~

~~—makes the decision to select channel type (point to multipoint or point to point) based on the number of users within a cell receiving MBMS service. The threshold value for this is operator defined~~

### ~~6.2 SGSN Functions~~

~~A number of functions provided by the SGSN for ptp bearer services may be used to provide MBMS:~~

~~—The SGSN authenticates users based on subscription data from HLR~~

~~—The SGSN authorises the usage of services/resources based on subscription data from HLR~~

~~—The SGSN provides user individual service control (ptp services)~~

~~—The SGSN provides user individual mobility management~~

~~—The SGSN may limit the service area per individual user~~

~~—The SGSN stores contexts per activated service per individual user~~

~~—The SGSN generates charging data per service for each user~~

~~—The SGSN provides CAMEL functions (e.g. prepaid)~~

~~—The SGSN establishes RABs on demand when data has to be transferred to the users~~

~~All these functions may be used in an MBMS architecture (potentially with modifications) for user individual control of MBMS multicast services, i.e. to activate, deactivate, authorise, ... the MBMS services for individual users. The mechanisms for provision of RABs on demand when data is to transfer may need extensions to provide shared resources for MBMS.~~

### ~~6.3 GGSN functions~~

~~The functions a GGSN could provide for MBMS are:~~

~~—Message Screening~~

~~—Charging Data Collection~~

~~—Mobility management~~

~~—Tunnelling of data~~

~~—Service (QoS) negotiation~~

~~—Policing~~

~~Message screening is not needed if the MBMS sources are internal in the PLMN or it is provided by the BM-SC or the BG which are gateways to external MBMS data sources.~~



Charging data may be collected for the MBMS data sources. But, the potential existing sources like ESS or MMS provide charging information and very likely also the BM-SC. User individual charging information is collected by the SGSN. It is not favourable to keep user individual contexts per multicast service in the SGSN and in the GGSN in parallel under the assumption that such user individual contexts are stored as long as the user is attached.

The mobility management of the GGSN can not support MBMS as the GTP tunnels would be fixed. These tunnels are used by multiple UEs in parallel and can not move with UEs.

The tunnelling seems the most important GGSN function for MBMS. It allows the provision of HPLMN MBMS multicast services to users roaming in a VPLMN. The tunnelling separates the traffic of the different MBMS services from each other and allows therefore the use of the same addresses in HPLMN and VPLMN. A co-ordination of addresses between different PLMNs is not needed.

A GGSN could simplify O&M when used to provide the parameters for the individual MBMS services at the service negotiation when the GTP tunnels are established. This approach has limitation when different configurations are required for the same service (potentially one SGSN has to provide different MBMS data for the same service in different areas, e.g. regional news). Then it has to be configured differently on the SGSN. Also the broadcast service needs to be configured on the SGSN, as there is no signalling with UEs which could trigger a tunnel establishment between SGSN and GGSN.

The GGSN could police the traffic of the individual MBMS services. But, most MBMS data sources are allocated within the PLMN and therefore under control of the operator. In addition, the QoS profile is very likely configured on the SGSN. And, the RAB will limit the possible throughput to the maximum bitrate and inherently police the traffic.

Most of the GGSN functions described above do not add any functionality useful for MBMS. Only for provision of HPLMN MBMS services to roaming users a GGSN is added to the architecture. The same approach is used for provision of MBMS services within one PLMN to avoid two different architectures.

#### 6.4 UE functions

—After activation of a MBMS service, the UE shall be able to receive MBMS data without explicit user request.

—UEs, which store MBMS data, may have functionality for Digital Rights Management.

—The UE shall be able to receive indications for other services e.g. paging in CS. However, this may create losses for which the MBMS applications shall cope with.

—The UE shall allow reception of MBMS service announcements while receiving MBMS data.

—The UE shall provide the functions to activate/deactivate MBMS data reception.

—The UE should support security functions for the provision of MBMS service.

##### 6.4.1 UE Functional Split Considerations

With the aim of enabling UE borne applications to use MBMS in receiving broadcast or multicast transmissions, the UE shall offer the following functions to applications:

—TE request to perform MBMS broadcast activation for a given broadcast service and to receive service related data.

—TE request to perform MBMS multicast activation (join) for a given multicast service and to receive service related data.

—TE request to perform MBMS broadcast deactivation for an activated broadcast service and to cease service related data reception.

—TE request to perform MBMS multicast deactivation for an activated multicast service and to cease service related data reception.

Note: For broadcast activation and deactivation, it is assumed that no signalling between UE and network is necessary.

#### 6.5 Other MBMS functions

Besides the user individual service control functions comparable to the functions already provided by an SGSN or GGSN there are some additional functions required for MBMS, mainly the specific data transport. It is assumed, that the SGSN performs the user individual service control, generates the charging data per user and establishes the RABs

when MBMS data is to transfer. The SGSN concentrates all user individual services into one MBMS service for each specific MBMS service. This includes the establishment of a number of RABs to transfer MBMS data to the radio network entities of the related service area and it includes a single connection between the SGSN and the GGSN for each individual MBMS service. The SGSN duplicates the data received from the GGSN for each RAB established for the service. Similarly, the GGSN duplicates data received from the MBMS source for each GTP tunnel related to the same MBMS service.

## 6.6 MBMS Context

The entities of the PLMN that provide MBMS services maintain one or more MBMS contexts for each active MBMS service. An MBMS context contains information and parameters necessary for each MBMS service. An MBMS context contains among others the PDP address, which is the IP address of the MBMS service (IP Multicast address), and the APN used to access the MBMS service. The combination of the PDP address and the APN uniquely identify the MBMS service. Other content of the MBMS context is FFS. It is FFS whether PLMN entities maintain service specific MBMS contexts per UE, per network entity, or both.

### 6.7 BM-SC functions

BM-SC should provide the following functions for MBMS:

- Authorization and authentication of content providers;
- Verify integrity of data received from content provider;
- Determine quality of service for MBMS transmissions (within operator configured QoS bounds);
- MBMS data repetition and error resilient schemes to cope with possible transmission loss;
- Content provider charging;

Further the BM-SC

- shall support functions to allow a content provider to select from operator defined broadcast or multicast areas for a MBMS service;
- shall be able to support several MBMS services taking into account their respective delivery constraints;
- shall provide functions to produce service announcements for the UE. The service announcement may include information about the required UE capabilities;
- shall provide functions to schedule MBMS data;
- shall be able to support one or more service providers

### 6.8 CBC functions

The Cell Broadcast Centre (CBC) may be used to announce MBMS services to the users. The functions a CBC could provide for MBMS service announcement are FFS:

### 6.9 MBMS Data Transfer in the Core Network

Multicast data must be available at the RNCs to be sent over the radio. The options for the data path are to send multicast data from a multicast "source" (could be a multicast server or multicast capable node) to:

1. all RNCs
2. only to selected RNCs which have multicast users;
3. to the all SGSNs to be further distributed by the SGSN to the RNCs, or
4. to selected SGSNs which have multicast users to be further distributed by the SGSN to the RNCs, or
5. to selected GGSN which support multicast service (possibly identified using APNs) and to be further distributed from the GGSN towards the RNCs.

The first option is wasteful of network resources and also makes it difficult to send data to VPLMNs for roaming users. The second option, an optimisation of the first one, is to send data only to RNCs with multicast users within the PLMN

under control of the activation centre but this cannot support roaming users either. Handling user mobility is also an issue here if for example the UE is in PMM idle.

Sending data to the GGSN in the last option is a good choice to support roaming users. The data is then multicast to the SGSNs with registered multicast users. Sending data through the SGSN—either directly (the third option) or via the GGSN (the last option)—has advantages since the SGSN is aware of the user location information even in PMM idle state but the use of Iu flex introduces complexities. Each SGSN node may use the routing area update procedure to help determine whether a multicast group user exists within its service area.

A combination of the above listed options can also be used—with direct transfer to RNC for the home users and via the GGSN to the roaming user.

The protocol to use to send data to the RNC or SGSN (if they are the recipient NE as per options discussed above) could be GTP or using IP multicast. Using IP multicast would be more efficient over the transport network if it supports multicast routers

Where the option to optimise and send data only to selected NEs is chosen, a signalling mechanism must be used to identify the appropriate nodes to set up the data path. If the data path is through the SGSN and GGSN, signalling similar to the existing GTP-C can be used to set up the tunnels. If IP multicast is used, the NEs wanting to receive multicast data, such as RNC or GGSN that have multicast users, could indicate its inclusion using IGMP/MLD.

The selection of an option is FFS.

#### 6.9.1 Use of IP Unicast on Iu and Gn

The figure below shows the use of IP unicast to optimise the user plane on the Gn interface. It is possible to use a single user plane connection to each SGSN, but this approach has a number of disadvantages:

—The GGSN and SGSN require new functions to manage the MBMS distribution tree, and to fork MBMS data to multiple destinations.

—The architecture has poor scaling because:

o packets are forked near the top of the tree

o forking takes place at a single point for all receivers—creating a single point of high load.

A similar discussion applies to the Iu interface.

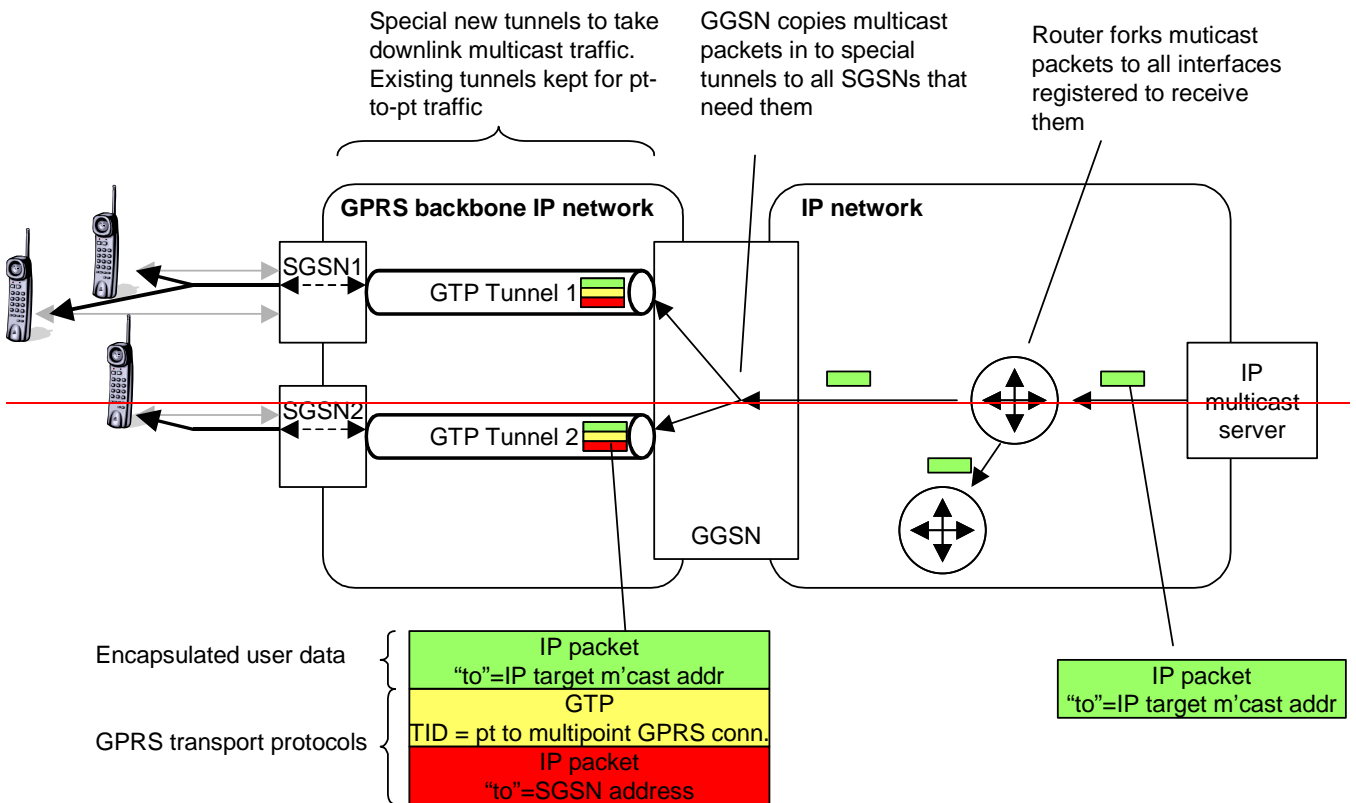

Figure 4: Optimised User Plane connections using IP unicast on the Gn interface

### 6.9.1.1 Use of IP Multicast on Iu and Gn

An alternative optimisation is to use special IP multicast groups within the GPRS backbone to transport data on the Gn interface. Instead of unicasting data to each individual SGSN, the GGSN only needs to forward packets once addressed to a specific multicast group. All SGSNs that need to receive this data can then register to receive the multicast group. Forking will be done by IP routers (assuming that multicast is supported).

The advantages of this approach are:

**Scaling**—this solution scales well because it exploits the scaling ability of IP multicast

**Low impact on GGSN**—GGSN doesn't have to copy packets on to multiple tunnels or manage list of SGSN receivers

**Efficiency**—IP routers will only fork the tunnels close to the end points. The previous solution forks the tunnels at the GGSN

It shall be noted that:

IGMP needs to be supported in the SGSN,

routers in the UMTS internal IP Network have to support IP Multicast,

coordination of private IP multicast addresses between networks has to be studied for case when the UE is in a VPLMN and activation is done via the HPLMN GGSN.

A similar discussion applies to the Iu interface.

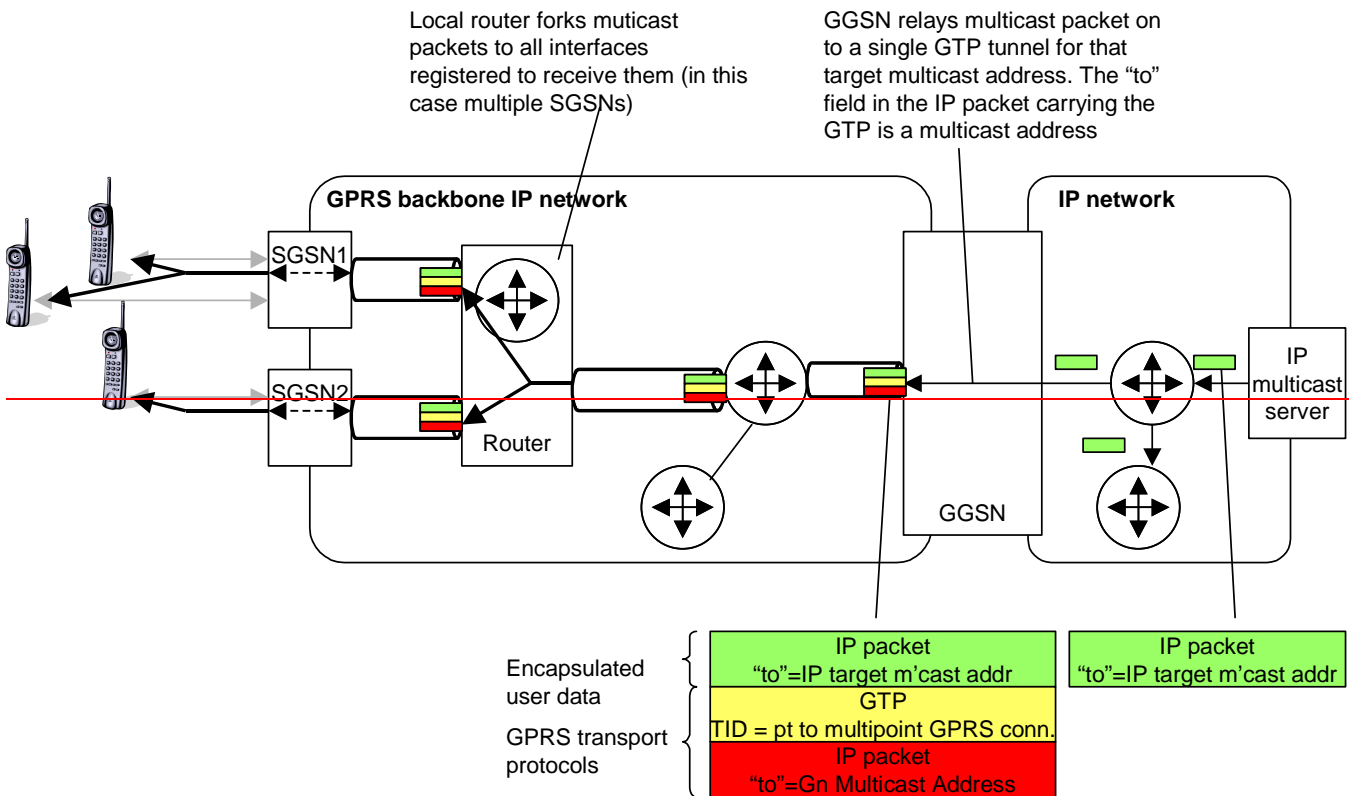

Figure 5: Optimised User Plane connections using IP multicast on the Gn interface

6.9.1.2 Example Activation Procedure on Gn

The following diagram shows an example activation procedure on Gn if IP multicast transport is used. Associated Iu procedures are now shown.

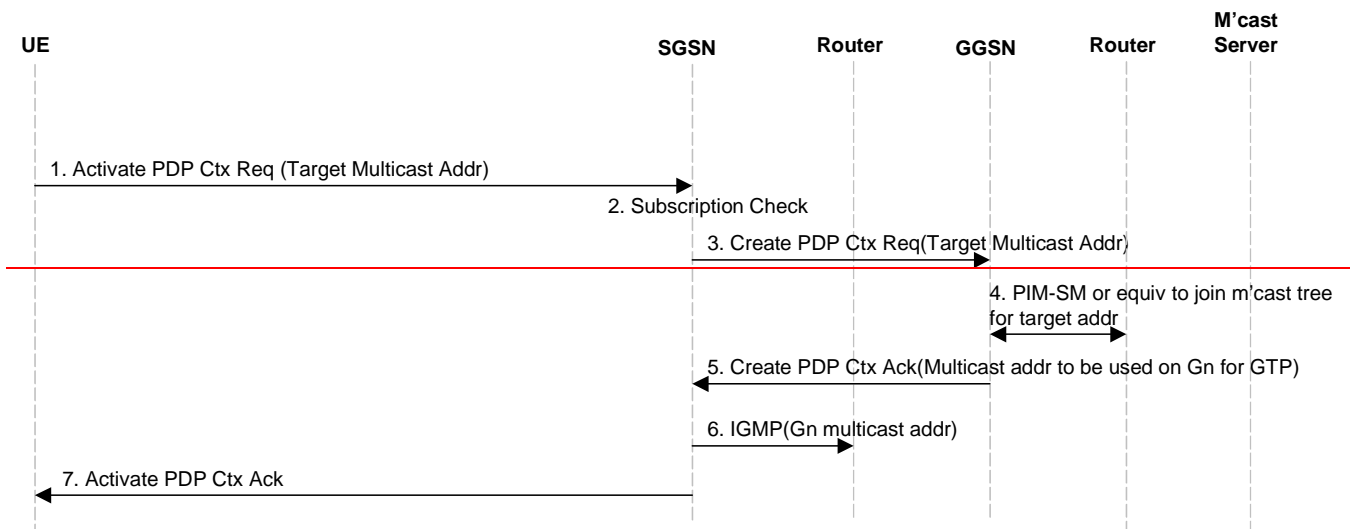

Figure 6— Example activation procedure

- 1— A PDP context is established to receive multicast packets sent to the Target IP Multicast Address.
- 2— The SGSN may perform a subscription check.
- 3— The SGSN requests the GGSN to receive packets from the target multicast address.
- 4— If the GGSN is not already registered to receive multicast packets sent to the Target IP Multicast Address it registers with its peer router.

5—The GGSN acknowledges the request. It provides the SGSN with the GTP TID (GPRS Tunneling Protocol Transaction ID) that will be used for the multicast tunnel and also the IP multicast address it will use to send the GTP packets on the Gn interface. The IP multicast address for the GTP tunnel should be chosen from a pool managed by the GGSN.

6—If the SGSN is not already registered to receive multicast packets sent to the Gn IP Multicast Address, it registers with its adjacent router

7—The SGSN passes back to the mobile an acknowledgement

### 6.10—Intra Domain Connection of RAN Nodes to Multiple CN Nodes (Iu Flex)

Iu flex brings some complications to the multicast architecture. Iu flex allows users on the same RNC to be registered in different SGSNs. Hence following the normal method of user plane using the same SGSN as the user is registered in could result in multiple streams to the RNC.

Whenever a GTP tunnel has to be set up between the RNC and the CN for multicast bearers, (either due to relocation or service initiation), and Iu Flex is configured in the network then the following options are available to reduce the impact on the network resource usage

Options are:

- 1. Use of a Default SGSN
- 2. Permitting multiple streams to RNC
- 3. Bypassing SGSN
- 4. RNC initiates only required number of RABs

#### 6.10.1 Option 1: Default SGSN

- 1. As a result of activation or relocation, the RNC has to decide whether a multicast stream has to be established for that user or whether he can be added to an existing stream (this is assuming the network is using a point to multipoint link).
- 2. In order to ensure only one source of data to the RNC, the RNC has to have a known “default SGSN”, which it uses to establish a pre-configured path for the multicast stream.
- 3. A control RAB will be established between the RNC and the SGSN the user is registered in.
- 4. Volume based charging will be restricted.

In this option, SGSN 1 is the “default SGSN”. Only one RAB is established across the Iu interface.

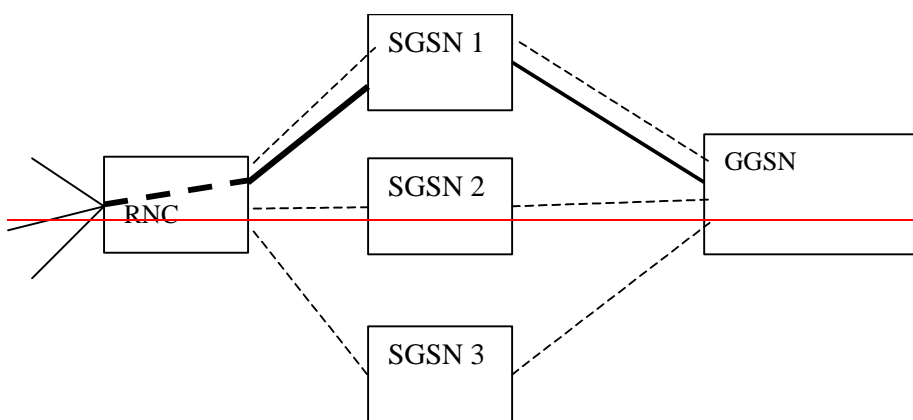

Figure 7.

#### 6.10.2 Option 2 “SGSN Bypass”

This option would require GTP tunnel establishment and release for the user plane between the GGSN and RNC, without the SGSN being involved. Control plane information remains via the SGSN. Removing the SGSN from the data

path would remove the inter operator exposure available between SGSN and GGSN for roaming. Volume based charging would be restricted.

Signalling -----  
Data \_\_\_\_\_

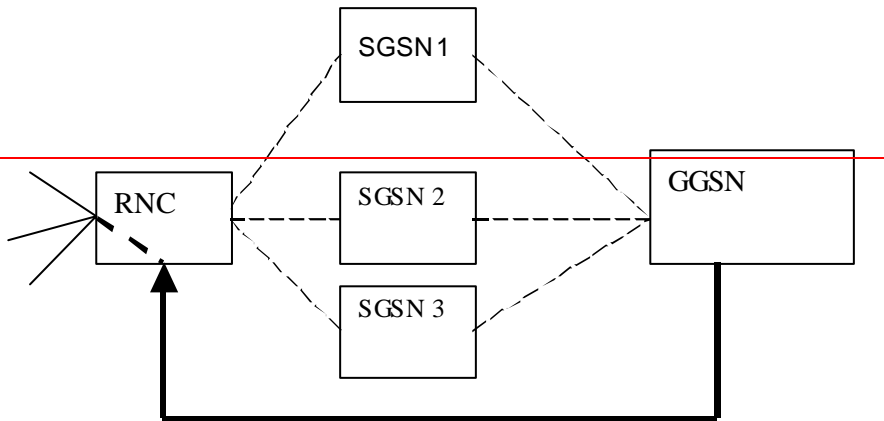

Figure 8.

6.10.3 Option 3 RNC decides on the Multicast Stream

In this option, the RNC is permitted to receive multiple streams. It then decides to take only one of the streams.

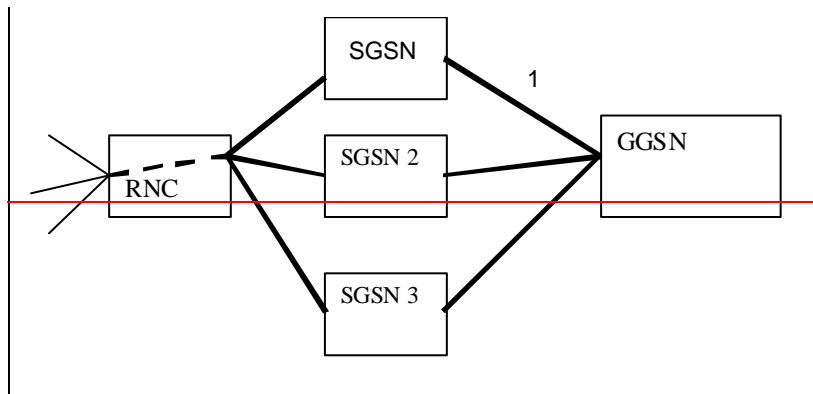

Figure 9.

6.10.4 Option 4 "RNC initiates only required number of RABs"

When the data transfer starts for an MBMS multicast the RNC detects that multiple SGSN send notifications to establish the same service. The RNC establishes the multicast RAB with only one SGSN. The other SGSNs establish no RABs for the MBMS multicast. But, the other SGSN receive the MBMS multicast data from the GGSN and generate volume charging information for the attached UEs.

If IU Flex is employed, it is possible for users within a multicast group to be served by the same RNC but different SGSN. In this situation some of the MBMS IE must be the same even though different SGSNs may be involved.

It is FFS how this is done but the following solutions could be considered:

- a) These IE can be assigned by the same network element
- b) A consistent rule is applied unlike the random generation as used in the TMSI
- e) Synchronization between different SGSNs.

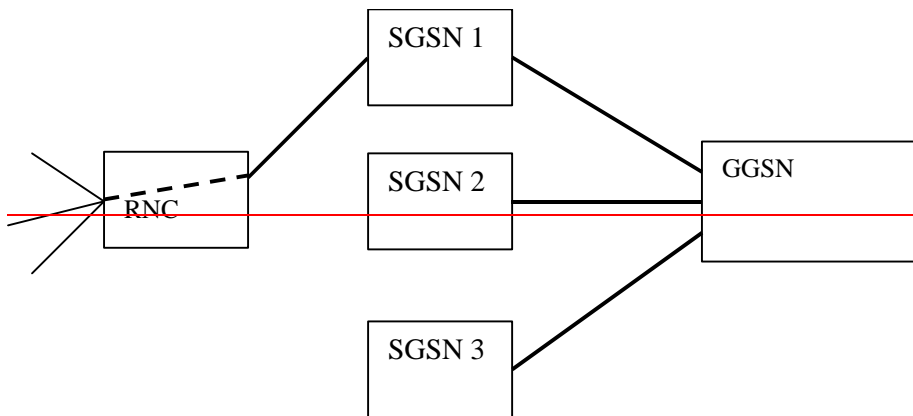

Figure 10.

### 6.11 Packet Temporary Mobile Group Identity in MBMS

In order to avoid congestion of the paging channels (at least in GSM), one solution is to allocate one common identity to all members of each multicast group, which are served by the same SGSN. This Temporary Mobile Group Identity (TMGI) could be allocated during a Routing Area Update, a GPRS Attach or a P-TMSI Reallocation procedure before the MBMS data transfer (e.g. the first TMGI allocation might occur when the mobile joins the IP multicast group). Separate multicast groups have different TMGIs. TMGIs may also be used to notify users of broadcast transmissions. It is FFS whether the same TMGIs can be used in more than one SGSN.

### 6.12 Decision process for selection of point-to-point or point-to-multipoint configuration

#### 6.12.1 Multicast Mode

To ensure that radio resources are not wasted, the radio network needs to estimate the number of users in a cell in order to determine whether to establish a point-to-multipoint channel in that cell or point-to-point channels to each user.

In the event of the number of users within a cell exceeding an operator defined threshold, the radio network will establish a point-to-multipoint channel in that cell.

If a point-to-multipoint channel has been established and the number of users drops below an operator defined value then the radio network may be required to drop back to point-to-point channels.

Note: The two thresholds may be different.

It is FFS whether this change of channel can occur whilst data is being broadcast/multicast.

### 6.13 Service Announcement/Discovery

MBMS service announcement/discovery mechanisms should allow users to request or be informed about the range of MBMS services available. This includes operator specific MBMS services as well as services from content providers outside of the PLMN.

Operators/service providers may consider several service discovery mechanisms. This could include standard mechanisms such as SMS, or depending on the capability of the terminal, applications that encourage user interrogation. The method chosen to inform users about MBMS services may have to account for the users location, (e.g. current cell, in the HPLMN or VPLMN). Users who have not already subscribed to a MBMS service should also be able to discover MBMS services.

The following could be considered useful for MBMS service discovery mechanisms (not exhaustive):--

- SMS CB
- MBMS Broadcast mode to advertise MBMS Multicast Services
- PUSH mechanism (WAP, SMS PP)
- Web URL

### 6.14 Quality of Service



~~It shall be possible for the network to control quality of service parameters for multicast and broadcast sessions. All QoS parameters described in [4] shall be supported with the following changes:~~

~~–For traffic class, only the background and streaming classes shall be supported.~~

#### ~~6.14.1 MBMS QoS is a MBMS service attribute~~

~~MBMS data will be distributed to multiple users, so that the QoS cannot be associated to one UE in particular.~~

#### ~~6.14.2 MBMS QoS over the MBMS distribution tree~~

~~MBMS data will be distributed to multiple users through a MBMS distribution tree that can go through many RNCs and many SGSNs. Furthermore some transport resources may be shared between many users accessing the same service in order to save resources.~~

~~As a consequence, each branch of a MBMS distribution tree shall be established with the same QoS. The MBMS distribution tree shall have the same QoS for all its branches. It is FFS whether an MBMS service can be provided over multiple distribution trees with differing QoS profiles.~~

~~When a branch of the MBMS distribution tree has been created, it is not desirable that the construction of another branch due to arrival of a new UE (or change of location of a UE with removal of a branch and addition of a new one) impacts the already established branches. Else, this imply a heavy mechanism to adjust the QoS of all the already established MBMS branches. As a consequence, QoS negotiation shall not be done by the network nodes. One of the consequence is that some branches may not be established if QoS requirement cannot be accepted by the concerned network node.~~

~~QoS negotiation should not be allowed by UMTS network elements.~~

~~QoS re negotiation feature in the RNC should not be allowed for MBMS service.~~

### ~~7 Network and Protocol Architecture~~

~~Options for different network architectures together with a rough description of necessary functionality, procedures, information flows and alterations required for network elements and protocols.~~

#### ~~7.1 Option A)~~

~~This architecture option differentiates between the procedure for MBMS multicast service activation and the procedure for MBMS RAB set up. The MBMS multicast activation procedure adds an individual UE to all contexts, which describe an MBMS multicast service within the network (the UE joins the multicast group). And this procedure establishes shared MBMS data links within the Core Network between GSNs and BM-SC on demand. The MBMS multicast activation procedure is performed for an individual UE. It has no influence whether data transfer to the multicast group is ongoing or not.~~

~~MBMS RABs are not established by the MBMS multicast activation procedure. The MBMS RABs are established for the multicast group and not for individual UEs by the MBMS RAB set up procedure when MBMS multicast data are available for transfer.~~

~~This architecture option establishes data transfer resources only for RNCs and SGSNs that have users of the related MBMS multicast service. This corresponds to options 2) and 4) discussed in clause “MBMS Data Transfer in the Core Network”.~~

~~The approach that solves Iu-Flex issues corresponds to options 2) and 4) discussed in clause “Intra-Domain Connection of RAN-Nodes to Multiple CN-Nodes (Iu-Flex)”.~~

#### ~~7.1.1 MBMS Multicast Service Activation~~

~~The activation procedure registers the user in the network to enable the reception of data from a specific MBMS multicast service. The activation is a signalling procedure between the UE and the network. It establishes the MBMS data transfer path within the network between SGSN(s) and BM-SC. The MBMS multicast service activation does not establish any RABs for the data transfer. The procedure is similar to the PDP context activation.~~

~~The activation of an MBMS multicast service without user interaction uses the same procedure. The mechanism which initiates this procedure in this case is FFS (e.g. a request from the network or triggered by data on the SIM after GPRS attach).~~

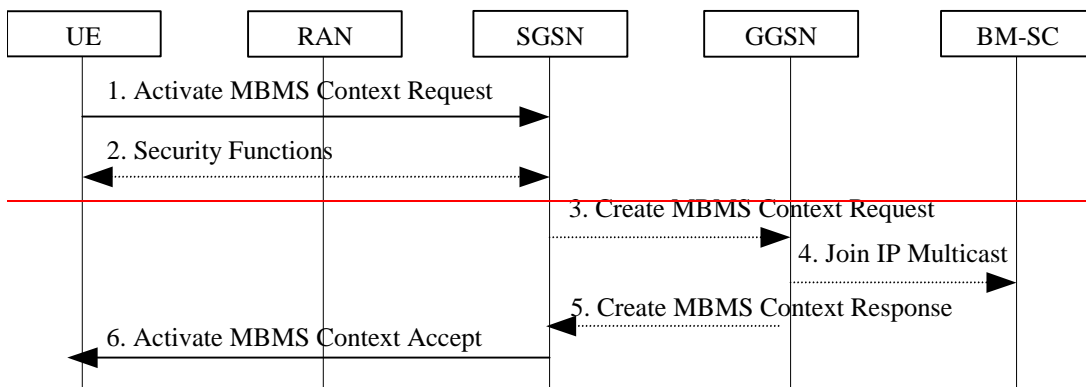

Figure 11. The activation of an MBMS multicast service

1) The UE sends an Activate MBMS Context Request to the SGSN. The IP-multicast address identifies the MBMS multicast service, which the UE wants to join. An APN indicates a specific GGSN or BM-SC. The SGSN creates a UE specific MBMS context, which stores the parameters of the activated MBMS multicast service.

2) Security Functions may be performed, e.g. to authenticate the UE.

3) The SGSN checks whether the requested MBMS multicast service identified by the IP-multicast address and APN requires a specific subscription or whether a general subscription (e.g. GPRS subscription) allows the activation of the requested service. If it is the first UE activating this specific MBMS multicast service on this SGSN the SGSN requests the creation of an MBMS context on the GGSN and the establishment of a GTP tunnel between the SGSN and the GGSN.

4) If it is the first GTP tunnel for this specific MBMS multicast service on the GGSN the GGSN joins the IP-multicast for the requested multicast IP address on the backbone to connect with the MBMS data source (BM-SC).

5) The GGSN confirms the establishment of the MBMS context if performed according to step 4).

6) The SGSN sends an Activate MBMS Context Accept to the UE with the parameter TMGI.

### 7.1.2 MBMS Broadcast Service activation

The MBMS broadcast service activation is local on the UE and local in the network. The user enables on the UE the reception of data from a specific MBMS broadcast service. This activation does not establish any data transfer resources.

The activation procedure in the network is comparable to the multicast activation. The connections within the network are set up when the SGSN re-starts or when an MBMS broadcast service is set up by O&M. The activation procedure establishes the MBMS data transfer path within the network between SGSN(s) and BM-SC. The MBMS broadcast service activation does not establish any RABs for the data transfer.

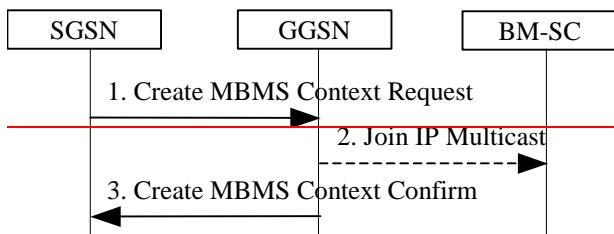

Figure 12. The activation of an MBMS broadcast service

1) At a SGSN re-start or when a new MBMS broadcast service is set up the SGSN requests the creation of an MBMS context on the GGSN and the establishment of a GTP tunnel between the SGSN and the GGSN.

2) If it is the first GTP tunnel for this specific MBMS multicast service the GGSN joins the IP-multicast for the requested multicast IP address on the backbone to connect with the MBMS data source (BM-SC).

3) The GGSN confirms the establishment of the MBMS context.

### 7.1.3 MBMS RAB set up

The MBMS RAB set up procedure establishes the RABs for a specific MBMS service when MBMS data have to be transferred. The procedure is used for MBMS broadcast and MBMS multicast data transfer.

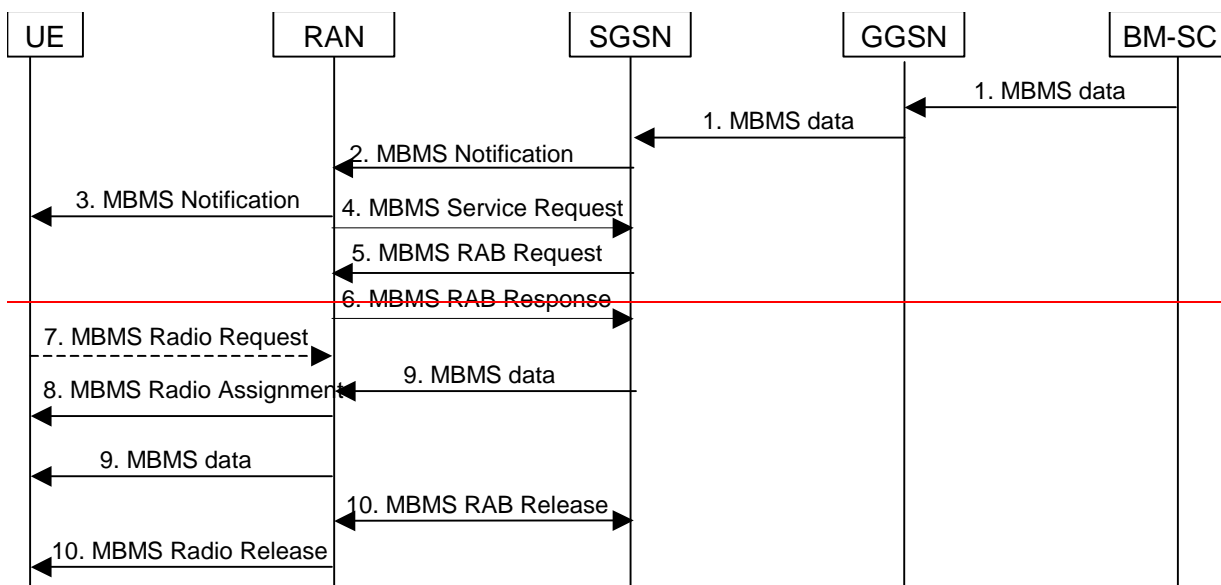

Figure 13. MBMS RAB set up

- 1) The BM-SC sends MBMS data that are received by the SGSN.
- 2) The SGSN sends an MBMS Notification to the RAN indicating the TMGI and the MBMS service area.
- 3) The RAN sends an MBMS Notification to the UEs within the MBMS service area.
- 4) The RAN sends one or multiple MBMS Service Request messages to the SGSN. The RAN may need one or multiple MBMS Iu bearers to cover the MBMS service area.
- 5) The SGSN sends per received MBMS Service Request an MBMS RAB Request message to the RAN. The message indicates the QoS parameters required for the RAB.
- 6) The RAN sends per MBMS RAB Request an MBMS RAB Response to the SGSN that establishes the MBMS Iu bearers between the RAN and the SGSN.
- 7) The UEs which have activated this MBMS service and which receive the MBMS Notification send an MBMS Radio Request message to the network. A back-off mechanism to prevent too many request messages is FFS.
- 8) The RAN establishes MBMS radio bearers and sends MBMS Radio Assignment messages in the cells where MBMS Radio Request messages were received.
- 9) When the MBMS Iu bearer between the RAN and the SGSN is established the SGSN starts to duplicate and to send received MBMS data on all established MBMS RABs. The RAN duplicates and sends these data on the MBMS radio bearer(s).
- 10) When the SGSN receives no more MBMS data it may release the MBMS RAB. This causes the RAN to release the MBMS radio bearers.

#### 7.1.4 Service Continuity and Mobility

##### 7.1.4.1 MBMS SGSN change procedure

This procedure is performed when a UE in GMM-IDLE changes the SGSN, i.e. there are no RABs and no signalling connections with the SGSN. The RABs for MBMS services are not exclusive for individual UEs. A signalling connection for an UE with MBMS services only is not intended as this is against the multicast concept. UEs which have only active MBMS services are therefore in GMM-IDLE. These UEs perform the Routing Area update with MBMS extensions as described below. The procedure is performed regardless whether MBMS data transfer is ongoing or not. The handling of potential ptp PDP contexts is not affected. The described procedure shows not all details of the Routing Area update procedure. The MBMS-specific additions to the Routing Area update procedure are in bold.

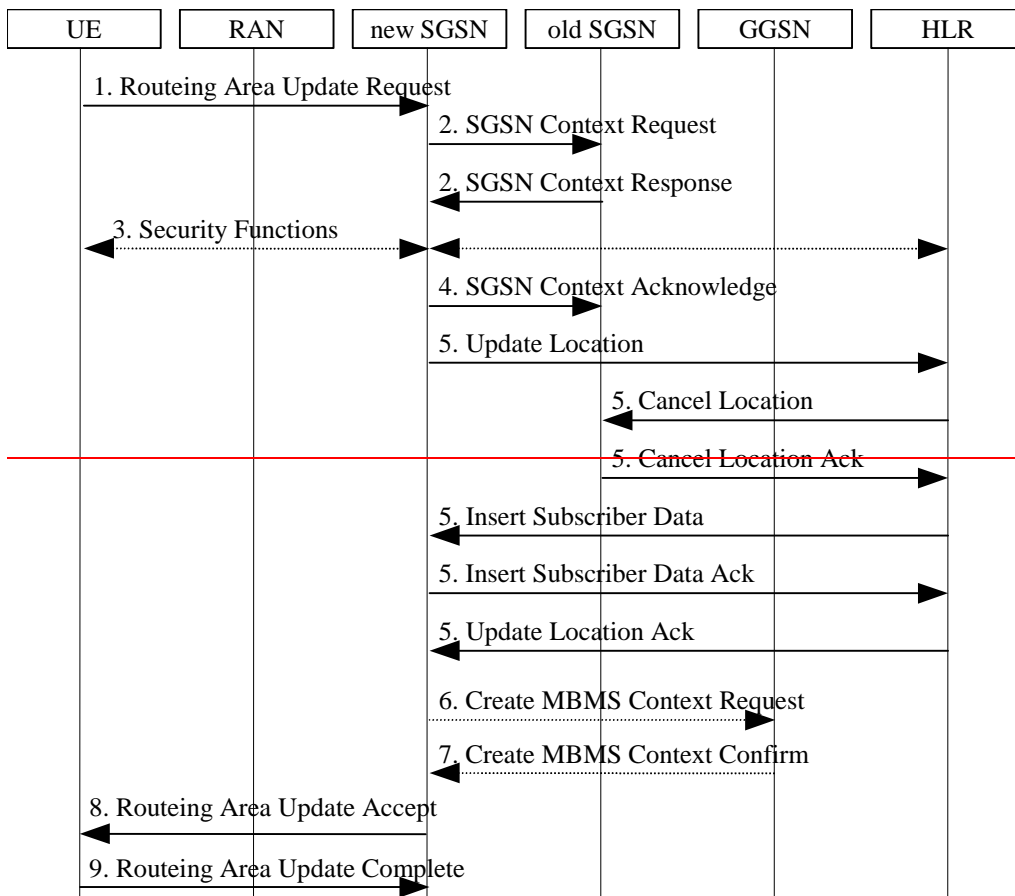

Figure 14. Mobility between SGSNs

- 1) The UE moves from the service area of the old SGSN to the service area of the new SGSN. The UE sends a Routeing Area Update Request to the new SGSN. The RAN shall add an identity of the area where the message was received before passing the message to the SGSN.
- 2) The new SGSN sends SGSN Context Request to the old SGSN to get the MM, the PDP and the MBMS contexts for the UE. The old SGSN sends all UE contexts with the SGSN Context Response to the new SGSN.
- 3) Security functions may be executed, e.g. authenticating the UE.
- 4) The new SGSN sends an SGSN Context Acknowledge message to the old SGSN to indicate that it has taken over the control for that UE.
- 5) All procedures to provide the subscription and security data in the new SGSN and to register the new SGSN at the HLR are performed.
- 6) The new SGSN validates the UE's presence. If due to roaming restrictions the UE is not allowed to be attached in the SGSN, or if subscription checking fails, the new SGSN rejects the routeing area update with an appropriate cause. If all checks are successful, the new SGSN constructs MM, PDP and MBMS contexts for the UE. The new SGSN checks each individual MBMS service indicated by the MBMS contexts of the UE. If it is the first UE with this specific MBMS multicast service on this SGSN the SGSN requests the creation of an MBMS context on the GGSN and the establishment of a GTP tunnel between the SGSN and the GGSN.
- 7) The GGSN confirms the establishment of the MBMS context if performed according to step 6.
- 8) The new SGSN responds to the UE with Routeing Area Update Accept. One or more TMGI may be allocated to the UE for MBMS.
- 9) The UE acknowledges the new parameters by returning a Routeing Area Update Complete.

7.1.4.2 MBMS relocation and handover

This procedure is performed when a UE in GMM-CONNECTED changes the SGSN, i.e. there is a signalling connections with the SGSN. The RABs of ptp services are transferred by relocation/handover. MBMS RABs are not exclusive for individual UEs. Active MBMS services of the UE are transferred to the new SGSN by the context transfer which is embedded in the relocation/handover procedures. The procedure is performed regardless whether MBMS data transfer is ongoing or not. The described procedure shows not all details of the relocation procedure. Only the relocation procedure is described. The handover procedure has similar extensions for MBMS. The MBMS specific additions to the relocation procedure are in bold.

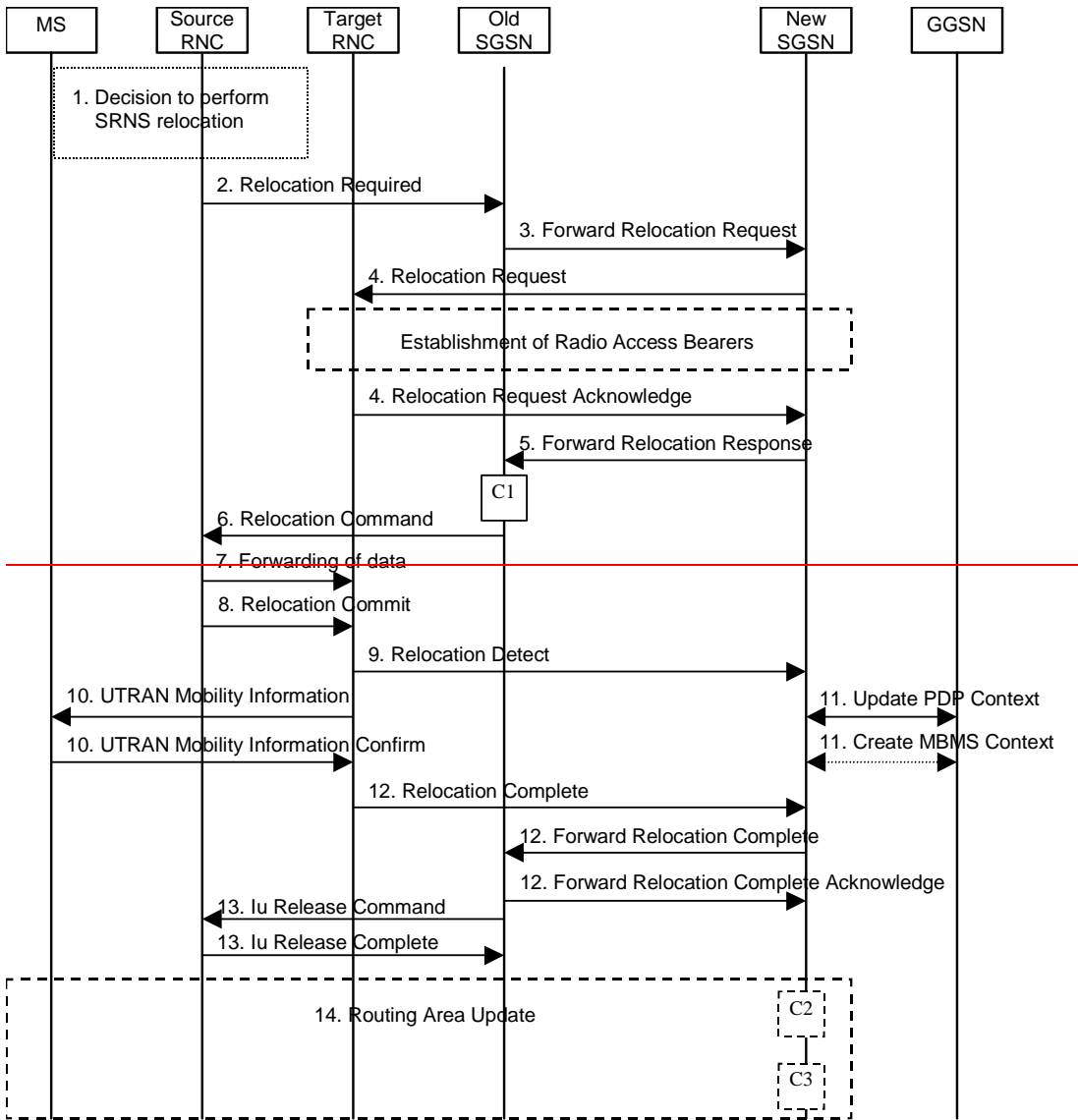

Figure 15.: SRNS Relocation Procedure

1) The source SRNC decides to perform/initiate SRNS relocation.

2) The source SRNC sends a Relocation Required message (Relocation Type, Cause, Source ID, Target ID, Source RNC to target RNC transparent container) to the old SGSN. The source SRNC shall set the Relocation Type to "UE not involved". The Source SRNC to Target RNC Transparent Container includes the necessary information for Relocation co-ordination, security functionality and RRC protocol context information (including MS Capabilities).

3) The old SGSN determines from the Target ID if the SRNS Relocation is an intra-SGSN SRNS relocation or an inter-SGSN SRNS relocation. In case of inter-SGSN SRNS relocation, the old SGSN initiates the relocation resource allocation procedure by sending a Forward Relocation Request message (IMSI, Tunnel Endpoint Identifier Signalling, MM Context, PDP Context, MBMS context, Target Identification, UTRAN transparent container, RANAP Cause) to the new SGSN. The Forward Relocation Request message is applicable only in the case of inter-SGSN SRNS relocation.

- 4) ~~The new SGSN sends a Relocation Request message (Permanent NAS UE Identity, Cause, CN-Domain Indicator, Source RNC to target RNC transparent container, RABs to be setup) to the target RNC. Only the Iu Bearers of the RABs are setup between the target RNC and the new SGSN as the existing Radio Bearers will be reallocated between the MS and the target RNC when the target RNC takes the role of the serving RNC.~~
- 5) ~~When resources for the transmission of user data between the target RNC and the new SGSN have been allocated and the new SGSN is ready for relocation of SRNS, the Forward Relocation Response message (Cause, RANAP Cause, and RAB-Setup Information) is sent from the new SGSN to old SGSN. This message indicates that the target RNC is ready to receive from source SRNC the forwarded downlink PDUs, i.e. the relocation resource allocation procedure is terminated successfully. The Forward Relocation Response message is applicable only in case of inter-SGSN SRNS relocation.~~
- 6) ~~The old SGSN continues the relocation of SRNS by sending a Relocation Command message (RABs to be released, and RABs subject to data forwarding) to the source SRNC. The old SGSN decides the RABs to be subject for data forwarding based on QoS, and those RABs shall be contained in RABs subject to data forwarding.~~
- 7) ~~The source SRNC may, according to the QoS profile, begin the forwarding of data for the RABs to be subject for data forwarding.~~
- 8) ~~Before sending the Relocation Commit the uplink and downlink data transfer in the source SRNC shall be suspended for RABs, which require delivery order. The source RNC shall start the data forwarding timer. When the source SRNC is ready, the source SRNC shall trigger the execution of relocation of SRNS by sending a Relocation Commit message (SRNS Contexts) to the target RNC over the Iur interface.~~
- 9) ~~The target RNC shall send a Relocation Detect message to the new SGSN when the relocation execution trigger is received. For SRNS relocation type "UE not involved", the relocation execution trigger is the reception of the Relocation Commit message from the Iur interface. When the Relocation Detect message is sent, the target RNC shall start SRNC operation.~~
- 10) ~~The target SRNC sends a UTRAN Mobility Information message. This message contains UE information elements and CN information elements. The UE information elements include among others new SRNC identity and S-RNTI. The CN information elements contain among others Location Area Identification and Routeing Area Identification. The procedure shall be co-ordinated in all Iu signalling connections existing for the MS.~~
- 11) ~~Upon receipt of the Relocation Detect message, the CN may switch the user plane from source RNC to target SRNC. If the SRNS Relocation is an inter-SGSN SRNS relocation, the new SGSN sends Update PDP Context Request messages to the GGSNs concerned. The GGSNs update their PDP context fields and return an Update PDP Context Response. If the SRNS Relocation is an inter-SGSN SRNS relocation, the new SGSN checks each individual MBMS service indicated by the MBMS contexts of the UE. If it is the first UE with this specific MBMS multicast service on this SGSN the SGSN requests the creation of an MBMS context on the GGSN and the establishment of a GTP tunnel between the SGSN and the GGSN.~~
- 12) ~~When the target SRNC receives the UTRAN Mobility Information Confirm message, i.e. the new SRNC-ID + S-RNTI are successfully exchanged with the MS by the radio protocols, the target SRNC shall initiate the Relocation Complete procedure by sending the Relocation Complete message to the new SGSN. The purpose of the Relocation Complete procedure is to indicate by the target SRNC the completion of the relocation of the SRNS to the CN.~~
- 13) ~~Upon receiving the Relocation Complete message or if it is an inter-SGSN SRNS relocation; the Forward Relocation Complete message, the old SGSN sends an Iu Release Command message to the source RNC. When the RNC data forwarding timer has expired the source RNC responds with an Iu Release Complete.~~
- 14) ~~After the MS has finished the RNTI reallocation procedure and if the new Routeing Area Identification is different from the old one, the MS initiates the Routeing Area Update procedure. See subclause "Location Management Procedures (Iu mode only)". Note that it is only a subset of the RA update procedure that is performed, since the MS is in PMM-CONNECTED mode. New TMGI(s) may be allocated to the UE for MBMS services.~~

#### ~~7.1.5 Service Deletion~~

#### ~~7.1.6 Interfaces to External Media Sources~~

#### ~~7.1.7 Roaming~~

#### ~~7.1.8 Security~~

#### ~~7.1.9 Charging~~

Error! No text of specified style in document.

**23**

Error! No text of specified style in document.

|

7.2 Option B)

7.2.1 MBMS Multicast Service Activation

7.2.2 MBMS Broadcast Service activation

7.2.2.1 Network initiated MBMS broadcast activation

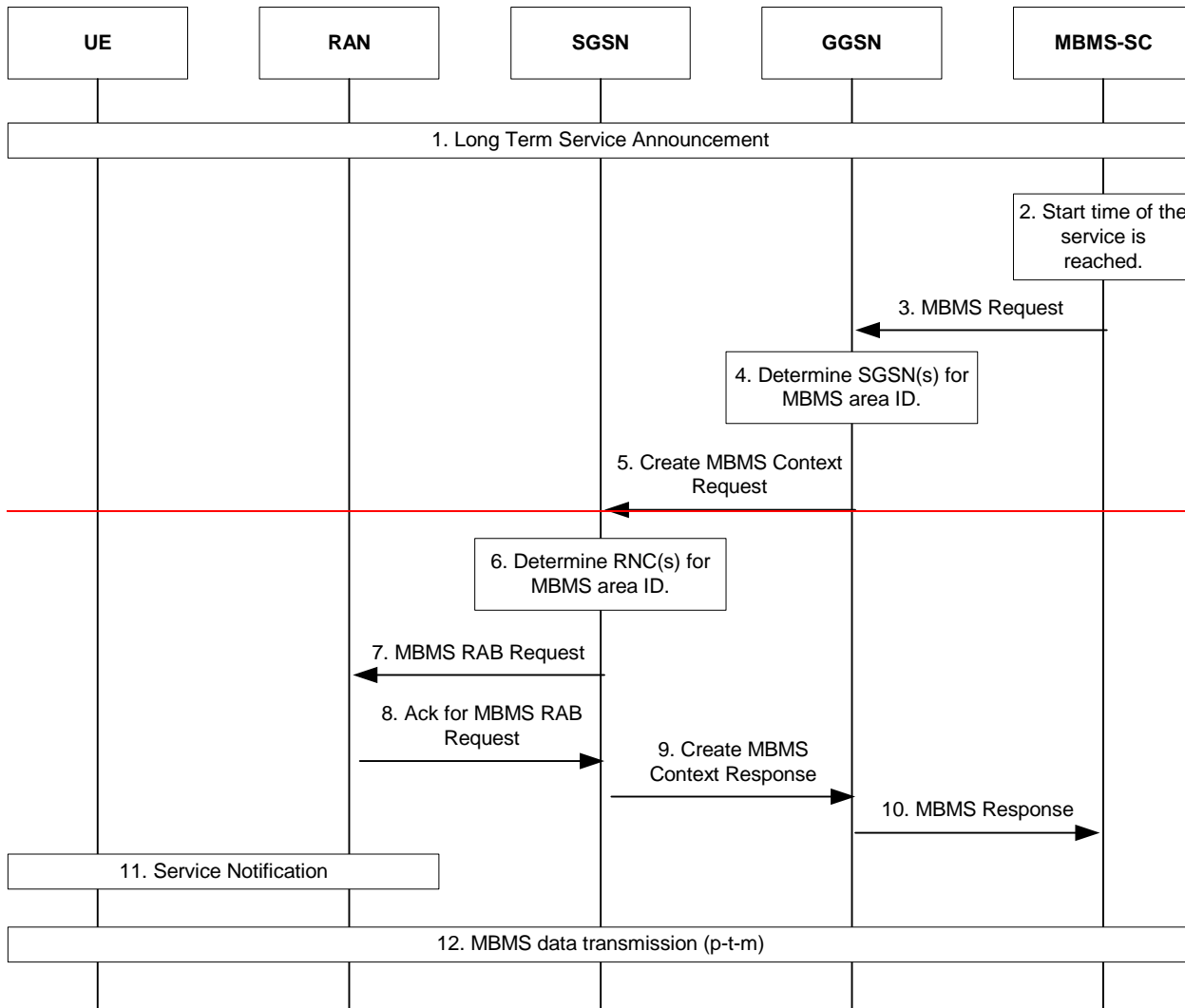

Figure 16. Network initiated activation.

- 1) Long Term Service Announcement procedure allows UE's to be informed of forthcoming services available.
- 2) MBMS service has scheduled a broadcast data transmission to start. MBMS-SC is awoken for the transmission. No MBMS bearer exists for the session.
- 3) MBMS-SC sends an activation message MBMS Request (MBMS ID (session identifier), broadcast area ID, QoS attributes) to the GGSN to ask a MBMS bearer activation for the service session.
- 4) GGSN finds out to which SGSNs to send the MBMS bearer activation request. How GGSN discover the SGSNs is FFS.
- 5) GGSN sends Create MBMS Context Request (MBMS ID, broadcast area ID, QoS attributes, GGSN address, TEID) to the SGSN(s) which belong to the broadcast area.
- 6) SGSN finds out to which RNCs to send MBMS RAB Request. How SGSN finds out the RNCs is FFS.
- 7) SGSN(s) initiates RAB establishment by sending MBMS RAB Request (MBMS ID, broadcast area ID, QoS attributes, SGSN address, TEID) to all of the RNCs which belong to the broadcast area.



8) If all required configurations and the resource reservations are successful in RAB setup, the RNC sends a positive acknowledgement to the SGSN. However if e.g. no resources are available for the MBMS services, the RNC sends the negative acknowledgement to the SGSN.

Negotiated QoS attributes may be included in the acknowledgement message if those were downgraded by RNC.

9) SGSN derives the QoS attributes towards GGSN. If MBMS RAB is established towards many RNCs, these RNCs may be able to provide different level of QoS to the MBMS RABs. In this case, SGSN may select either the highest QoS attributes or the lowest QoS attributes. If the lowest QoS attributes are selected, SGSN could modify other MBMS RABs accordingly. SGSN sends Create MBMS Context Response (SGSN address, TEID) to GGSN. Negotiated QoS attributes may be included if those were downgraded by RNC.

10) GGSN sends MBMS Response to MBMS-SC. Negotiated QoS attributes may be included if those were downgraded by RNC.

11) RAN node provides Service Notification which informs the UE about forthcoming (and possible other ongoing) data transfer. Service Notification can be send any time after succesfull RAB set up in step 8.

12) After the successful MBMS bearer activation the MBMS-SC starts transmitting the service data.

It should be noted that in the above scenario, the requested QoS attributes may be downgraded in RNC. This may happen also in other nodes along the signalling path. If QoS downgrading happens, a node indicates the downgraded QoS attributes and possibly the requested QoS attributes to the next node.

Note: The topic of QoS is FFS.

7.2.3 MBMS RAB set up

7.2.4 Service Continuity and Mobility

7.2.5 Service Deletion

7.2.6 Interfaces to External Media Sources

7.2.7 Roaming

7.2.8 Security

7.2.9 Charging

7.3 Option C)

7.3.1 MBMS Multicast Service Activation

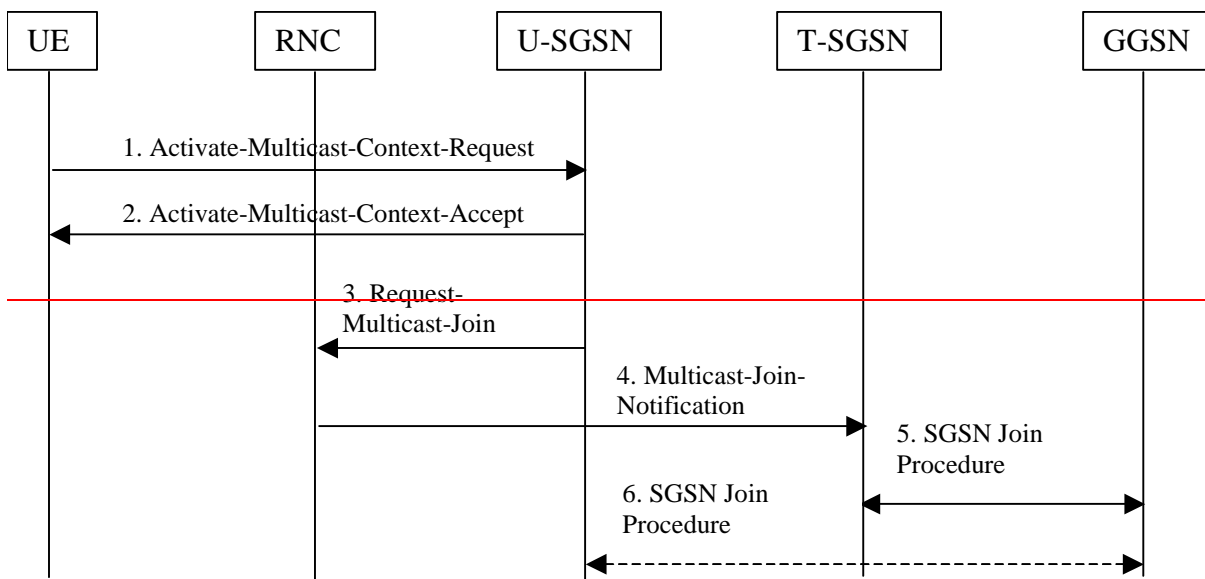

Figure 17.

- 1) UE Requests to join a specific multicast group and receive the associated service by sending an Activate Multicast Context Request containing a multicast address and APN identifying the group. The message is sent to the SGSN currently serving the user (U-SGSN).
  - 2) The U-SGSN checks for user authorization for joining the specific multicast group. If the user is authorized to join the requested multicast group, the SGSN returns an Activate Multicast Context Accept. Alternatively, if the user is not authorized to join the service the U-SGSN returns an Activate Multicast Context Reject.
  - 3) If the user is the first user to join the specific multicast group in the domain of the U-SGSN and Iu-flex is being used then the U-SGSN sends a Request Multicast Join to the RNC that is currently serving the user. The Request Multicast Join identifies the multicast group being joined by including the multicast address and APN received in (1). If Iu-flex is not being used, the U-SGSN assumes the role of the T-SGSN and carries out the procedure described in (5).
  - 4) If the RNC receives the first Request Multicast Join from the U-SGSN and the RNC is not joined to the specific group then the RNC sends a Multicast Join Notification to the SGSN designated to provide traffic for the specific multicast group (T-SGSN). The means by which an RNC chooses an SGSN, through which multicast traffic for a specific service should be routed, are implementation specific and are not subject to further standardization. The Multicast Join Notification identifies the group being joined by including the multicast address and APN received in (3).
  - 5) If the T-SGSN has previously joined the multicast group and while receiving the Multicast Join Notification the T-SGSN is in the process of relaying multicast traffic to other RNCs for the requested service then the T-SGSN sets up the necessary RAB(s) to the sending RNC as described in section 8.1.4.
  - 6) If the T-SGSN has not done so previously, the T-SGSN notifies the GGSN identified by the APN and associated with the specific multicast service of its wish to receive transmissions associated with the service. Since GTP-C uses unreliable transport, it is expected that the join procedure will consist of a request response message exchange.
- If the GGSN receives a T-SGSN request to join a given multicast service and a transmission for this service is ongoing, the GGSN should follow procedures described in 8.1.4 to set up bearers and begin transmission:
- 7) If the U-SGSN chooses to generate volume based charging information the U-SGSN might itself, follow procedures described in 5 and as a result would be offered to receive all service related traffic.

**Multicast Service Deactivation**

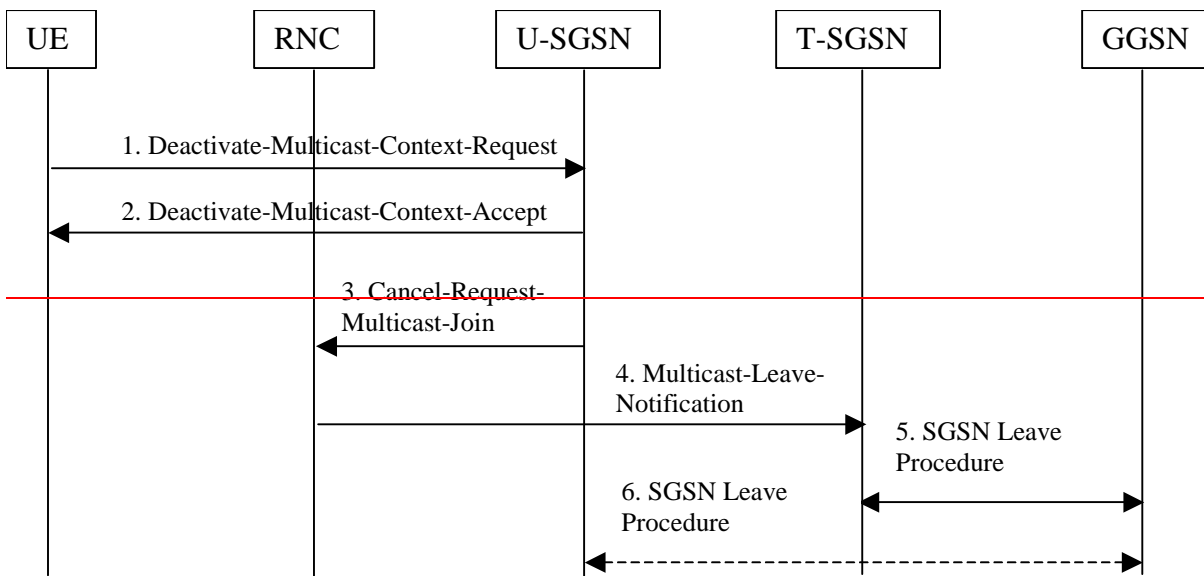

Figure 18.

- 1) UE Requests to leave a specific multicast group and cease reception of the associated service by sending a Deactivate Multicast Context Request containing a multicast address and APN identifying the group. The message is sent to the SGSN currently serving the user (U-SGSN).
- 2) The U-SGSN checks if the user has previously joined the identified multicast group and returns an Activate Multicast Context Accept if this is the case.

3) If the user is the last user to leave the specific multicast group in the domain of the U-SGSN and Iu-flex is being used then the U-SGSN sends a Cancel Request Multicast Join to the RNC that is currently serving the user. The Cancel Request Multicast Join identifies the multicast group being left by including the multicast address and APN received in (1). If Iu-flex is not being used, the U-SGSN assumes the role of the T-SGSN and carries out the procedure described in (5).

4) If the RNC receives a Cancel Request Multicast Join from the U-SGSN and at the time of reception no other SGSNs have asked the RNC to join the specified multicast group then the RNC sends a Multicast Leave Notification to the SGSN to which it previously sent the Multicast Join Notification (T-SGSN). The Multicast Leave Notification identifies the group being joined by including the multicast address and APN received in (3).

5) If upon reception of a Multicast Leave Notification, the T-SGSN happens to be in the process of relaying multicast transmissions as part of the specified service, the T-SGSN should terminate all service specific RABs to the sending RNC.

6) If at the time of reception of a Multicast Leave Notification the T-SGSN determines that no other RNCs have joined the specific multicast group, the T-SGSN notifies the GGSN identified by the APN and associated with the specific multicast service of its wish to cease reception of transmissions associated with the service. Since GTP-C uses unreliable transport, it is expected that the leave procedure will consist of a request-response message exchange.

If the GGSN has any ongoing transmissions to the specific T-SGSN, it should terminate these transmissions and free the associated resources.

7) If the U-SGSN has previously chosen to generate volume based charging information the U-SGSN shall itself follow procedures described in 5 and as a result would itself stop reception of all service related traffic.

7.3.2 MBMS Broadcast Service activation

7.3.3 MBMS RAB set up

**Initiating an MBMS Transmission**

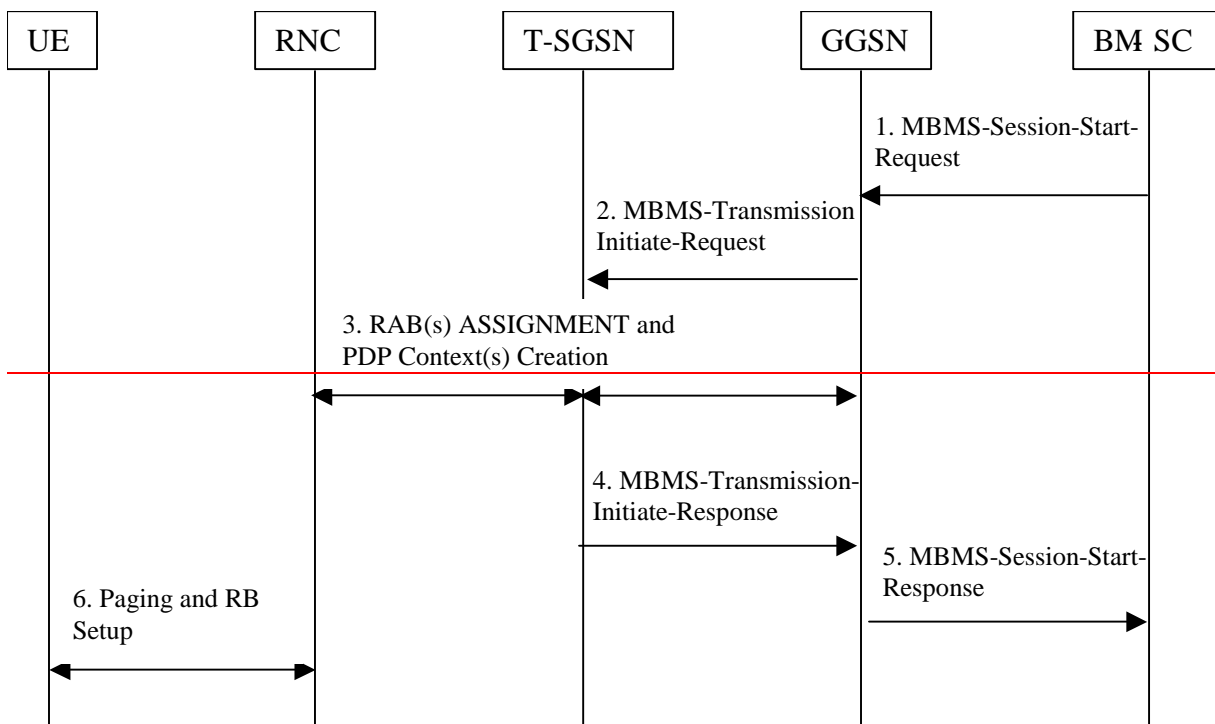

Figure 19. Initiating an MBMS Transmission

1) Upon content provider request, due to operator configuration or as part of a repetition scheme a BM-SC may wish to initiate a transmission over an MBMS bearer. In order to signal its wish to transmit and to request suitable quality of service for the coming transmission, the BM-SC sends an MBMS Session Start Request to the GGSN assigned to the specific service.

- 2) The GGSN sends an MBMS Transmission Initiate Request to all T-SGSNs which have requested to receive traffic associated with the service (as described in 8.1.2). The MBMS Transmission Initiate Request includes service parameters received from the BM-SC in (1).
- 3) Each T-SGSN requests the set-up of a suitable RAB(s) and GTP tunnels based on quality of service parameters as received in MBMS Transmission Initiate Request from GGSN. The GTP tunnels are set-up towards the GGSN from which the MBMS Transmission Initiate Request was received. The T-SGSN requests RAB set-ups to RNCs that have previously sent an RNC Join notification as described in 8.1.1.
- 4) Once RAB and GTP tunnel set-up is complete, the T-SGSN returns an MBMS Initiate Transmission Response specifying whether the procedure was successfully completed and possibly detailing those areas where RAB setup has failed.
- 5) GGSN responds with MBMS Session Start Response. The response indicates whether the bearers for transmission are available and if actual transmissions can start.
- 6) Actual paging of UEs and RB set-up procedures may be carried out, as RABs are set-up or at first packet arrival. This is currently left FFS.

**Terminating an MBMS Transmission**

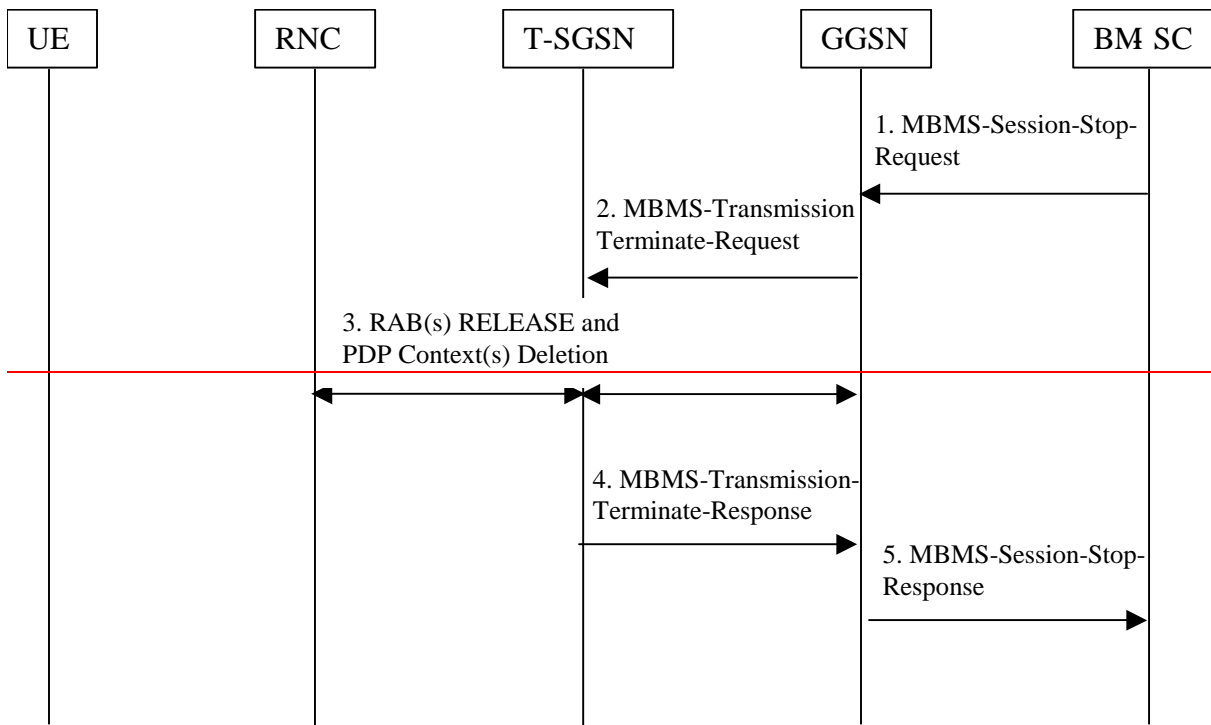

Figure 20. Terminating an MBMS Transmission

- 1) Upon content provider request, due to operator configuration or as part of a repetition scheme a BM-SC may wish to terminate a transmission over an MBMS bearer. In order to signal its wish terminate the transmission, the BM-SC sends an MBMS Session Stop Request to the GGSN assigned to the specific service.
- 2) The GGSN sends an MBMS Transmission Terminate Request to all T-SGSNs which are currently receiving traffic associated with the service (as described in 8.1.2).
- 3) Following MBMS Transmission Terminate Request, each T-SGSN terminates the RAB(s) and GTP tunnels previously set-up for carrying-out the transmission.
- 4) When all tunnels and RABs have been terminated, T-SGSN responds to the GGSN with an MBMS Transmission Terminate Response.
- 5) GGSN responds with MBMS Session Start Response.

7.3.4 Service Continuity and Mobility

~~7.3.5 Service Deletion~~

~~7.3.6 Interfaces to External Media Sources~~

~~7.3.7 Roaming~~

~~7.3.8 Security~~

~~7.3.9 Charging~~

7.4 Option D)

In order to allow the RNC to manage the UTRAN UE mobility for MBMS service as well as for non MBMS services, a MBMS specific context shall exist in the RNC for each UE activating a MBMS service and the Iu Control Plane should not be shared between UEs: one RAB establishment procedure shall be done for each UE activating a multicast MBMS service. A dedicated Iu Control plane shall exist for each UE activating a MBMS multicast service. In order to save resources over Iu, an Iu user plane between a RNC and a SGSN can be shared between UEs for the transport of data for the UEs that have activated the same MBMS multicast service.

On the Gn interface, a separate control plane shall be used for each UE with an active MBMS connection. A shared user plane may be applied to all UEs in the same SGSN

7.4.1 MBMS Multicast Service Activation

The activation procedure registers the user in the network to enable the reception of data from a specific MBMS multicast service. The activation is a signalling procedure between the UE and the network. The procedure is similar to the PDP context activation with the addition that user planes can be optimised to share resources between UEs that activate the same MBMS multicast service.

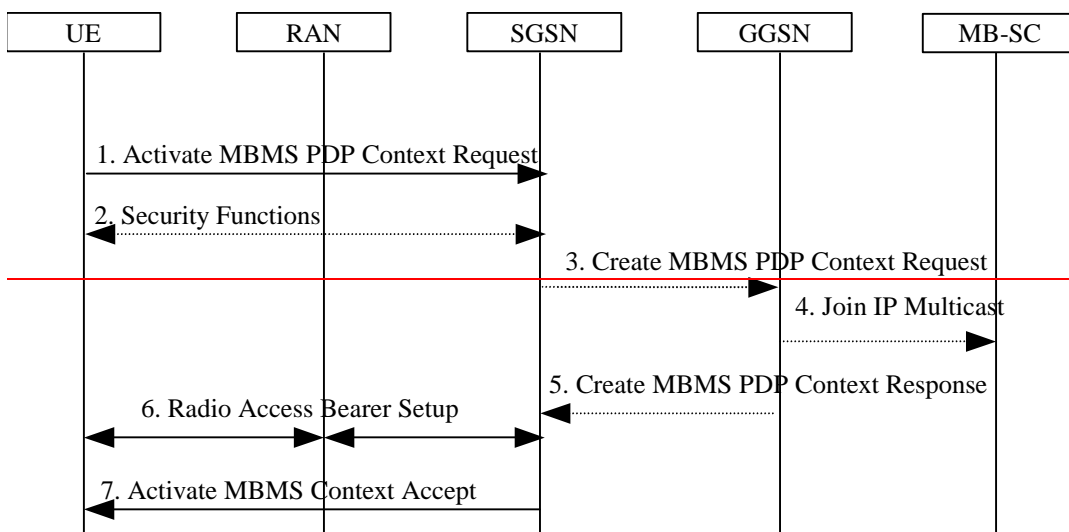

Figure 21. The activation of an MBMS multicast service

The activation of an MBMS multicast service

- 1) The UE sends an Activate MBMS PDP Context Request to the SGSN. The SGSN creates a UE specific MBMS context which stores the parameters of the activated MBMS multicast service.
- 2) Security Functions may be performed.
- 3) The SGSN sends a Create MBMS PDP Context Request message to the affected GGSN. If it is not the first UE activating this specific MBMS multicast service between this SGSN and the GGSN, the GTP user plane can be optimised and shared between all the UEs requesting the same MBMS multicast service.
- 4) If it is the first GTP tunnel for this specific MBMS multicast service on the GGSN the GGSN joins the IP multicast for the requested multicast IP address on the backbone to connect with the MBMS data source (BM-SC).
- 5) The GGSN confirms the establishment of the MBMS context if performed according to step 3).
- 6) The SGSN sends a RAB assignment request to the RAN in order to establish the Iu Control Plane and a UE specific MBMS context in the RAN. An optimisation of Iu user plane can be done to share Iu user plane for many UEs activating the same MBMS multicast service between a SGSN and a RNC.
- 7) The SGSN sends an Activate MBMS Context Accept to the UE.

7.4.2 MBMS Broadcast Service Activation

7.4.3 MBMS RAB set up

~~7.4.4 Service Deletion~~

~~7.4.5 Service Continuity and Mobility~~

~~7.4.6 Interfaces to External Media Sources~~

~~7.4.7 Roaming~~

~~7.4.8 Security~~

~~7.4.9 Charging~~

7.5 Option E)

7.5.1 MBMS Multicast Service Activation

7.5.2 MBMS Broadcast Service Activation

7.5.3 MBMS RAB set up

7.5.4 Service Deletion

7.5.4.1 Network Initiated Termination Mechanism for MBMS

7.5.4.1.1 Broadcast mode

After multimedia service has been delivered, the network should initiate “delete MBMS PDP context” under broadcast mode. This is to enable all network and UE resources to be released, e.g. Multicast address, APN, TMGI, NSAPI/TI, etc. In order to avoid signalling congestion, the signalling flows between UE and network are staggered in time. Typically they would be sent in parallel with the next (periodic) routing area update.

7.5.4.1.2 Multicast mode

There are two cases for MBMS termination under multicast mode: i.e. UE Initiated and Network Initiated. For UE Initiated, the UE can send a deactivate MBMS PDP context message to leave the multicast service. For Network Initiated, care is needed to avoid signalling channel congestion. In order to avoid this, the signalling flows between UE and network are staggered in time. Typically they would be sent in parallel with the next (periodic) routing area update.

7.5.4.1.3 Signalling flow for Network Initiated MBMS PDP context release

The MBMS PDP Context Deactivation Initiated by GGSN procedure is illustrated in Fig.1

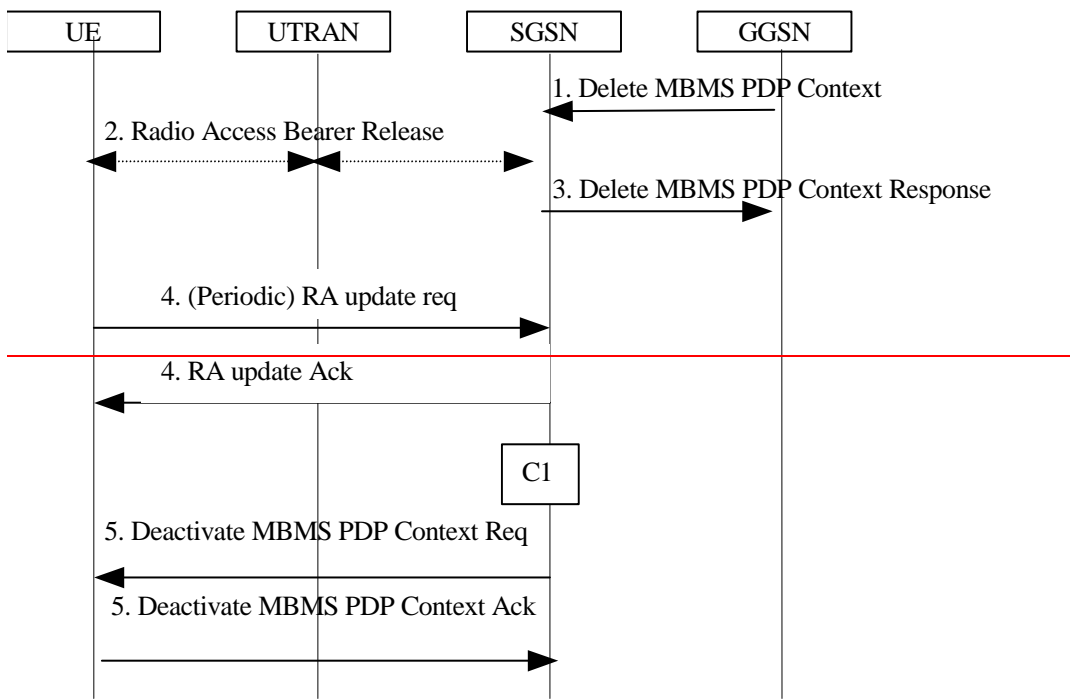

Figure 22. GGSN initiated MBMS PDP context deactivation procedure

- 1) The GGSN sends a Delete MBMS PDP Context Request (IP multicast address, APN, TEID, NSAPI) message to the SGSN.
- 2) In lu mode, radio access bearer release is done by the RAB Assignment procedure.
- 3) The SGSN returns a Delete MBMS PDP Context Response (IP multicast address, APN, TEID) message to the GGSN. [The GGSN releases the IP multicast address and makes it available for next multicast service.] The SGSN maintains a list of mobiles that it needs to inform that the MBMS PDP Context has been deactivated.



~~4) A UE performs a (periodic) RA update. The SGSN checks whether the UE has any MBMS PDP contexts that need to be deactivated.~~

~~5) The SGSN sends a Deactivate MBMS PDP Context Request (IP multicast address, APN, TI) message to the UE. The UE acknowledges the Context release.~~

~~The CAMEL procedure call shall be performed, see referenced procedure in 3GPP TS 23.078: C1)  
— CAMEL\_GPRS\_PDP\_Context\_Disconnection.~~

~~Note: the case of Network Initiated release after inter-SGSN RA update is FFS (however it is not believed to be difficult to solve).~~

#### ~~7.5.5 Service Continuity and Mobility~~

#### ~~7.5.6 Interfaces to External Media Sources~~

#### ~~7.5.7 Roaming~~

#### ~~7.5.8 Security~~

#### ~~7.5.9 Charging~~

### ~~8 CHARGING~~

~~MBMS architecture should provide flexible charging mechanisms for broadcast and multicast modes. This includes support for on-line and off-line charging.~~

#### ~~8.1 Charging for Broadcast mode~~

~~To enable billing of broadcast content providers, data shall be collected at the BM-SC.~~

~~In addition to this information listed in the stage 1, data will be needed on the number of cells in the broadcast area.~~

~~Examples of the type of the charging information that may be collected at the BM-SC include:~~

~~—service time and duration~~

~~—volume of data~~

~~—MBMS broadcast area~~

~~—number of cells in broadcast area~~

~~The above list of possible charging mechanisms is neither complete nor exhaustive.~~

#### ~~8.2 Charging for Multicast mode~~

~~It shall be possible to collect charging information (even when roaming) for the use of the multicast mode. Therefore, the following combinable charging mechanisms should be available for the multicast mode:~~

##### ~~8.2.1 Content Provider Charging Mechanism~~

~~To enable billing of multicast content providers, data shall be collected at the BM-SC.~~

~~In addition to this information listed in the stage 1, data will be needed on the number of cells in the multicast area.~~

~~Further, information may be needed on the proportion of users to whom the content was satisfactorily delivered FFS.~~

~~Examples of the type of the charging information that should be collected at the BM-SC include:~~

~~—service time and duration~~

~~—volume of data~~

~~—geographic area of multicast area~~

~~—number of cells in multicast area~~

~~Proportion of users who satisfactorily received the multicast is FFS.~~

~~The above list of possible charging mechanisms is neither complete nor exhaustive.~~

## ~~8.2.2 Subscriber Charging~~

### ~~8.2.2.1 On line charging~~

~~The architecture should enable the on line charging of multicast services. To enable this, CAMEL functionality on the SGSN might need to be extended. In addition the CSE may need to interact with the BM-SC to obtain, e.g., rating information. Other solutions to provide on line charging are not precluded.~~

### ~~8.2.2.2 Off line charging~~

~~The Multicast service should enable the user to be charged for the services that they receive. This charging might be either on the volume of data received and/or just on the fact that the user activated the multicast PDP context. SGSN charging data is also needed to handle cases where the SGSN is in a different network to the BM-SC. To achieve this, the SGSN should be able to generate charging information that include at least the following information:~~

~~—service time and duration~~

~~—volume of data~~

~~The above list of possible charging mechanisms is neither complete nor exhaustive.~~

## ~~9 Interaction with CS/PS services~~

### ~~10 Information Storage~~

## Annex A

This section contains text for information

### A.1 Decision process for selection of point-to-point or point-to-multipoint configuration

~~For GSM, one way to achieve this would be for the paging messages which carry the TMGI to also specify the value to be included by the mobile into any subsequent (Packet) Channel Request message. After receiving a page with their TMGI, each mobile sends one (Packet) Channel Request message with the value specified in the page message. The BSS then counts the number of (Packet) Channel Request messages containing the specified contents received in each cell. This method seems likely to give an accurate measure of either (a) how many mobiles belonging to that group are in the cell (if there are less than, say, 10 mobiles in the cell), or (b) whether there are more than, say, 10 mobiles belonging to that group in the cell.~~

~~For UMTS: the method is FFS~~

### A.2 One Tunnel vs. Multiple Tunnels

~~When only one GTP tunnel exists between the GGSN and the SGSN, the SGSN must~~

- ~~—Be able to create multiple GTP tunnels between itself and the RNCs serving MBMS receivers.~~
- ~~—Be able to duplicate MBMS data packets to these tunnels (between the SGSN and the RNCs) coming from the GGSN.~~

~~The other alternative of having only one GTP tunnel between the GGSN and the SGSN is to have multiple tunnels between these elements, i.e. one GTP tunnel for each RNC serving the MBMS receivers. These approaches are illustrated in Figure 23.~~

~~By having multiple tunnels, several benefits can be gained:~~

- ~~—There is no need to make changes to the current packet relaying in the SGSN. The SGSN does not have to duplicate packets from a Gn/Gp GTP tunnel to multiple Iu GTP tunnels.~~
- ~~—QoS handling does not require changes to the SGSN. With this approach RNCs may be able to provide different QoS, even though these RNCs would reside below the same SGSN. In the "one GTP tunnel between the GGSN and the SGSN" approach new logic is required in the SGSN to determine the QoS for the Gn/Gp tunnel.~~
- ~~—RAB release and Iu release do not require changes to the SGSN. Again, in the "one GTP tunnel between the GGSN and the SGSN" approach new logic is required in the SGSN to carry out these procedures.~~
- ~~—According to TS 22.146 (Chapters 5.1.1 and 5.2.1) and TR 23.846 (Chapter 6.1.2), it should be possible to send different data to different service areas for the same service (e.g. regional news). When multiple tunnels are used, different data can be flexibly sent to different RNCs (serving different service areas).~~

~~Thus, the approach of having multiple tunnels reuses the existing mechanisms and minimizes the changes to the existing infrastructure (architecture principle 4. in TR 23.846), but the expense is that the same data is delivered between the GGSN and the SGSN multiple times. When compared to the approach of having one tunnel, the situation is the opposite: in the solution utilizing one Gn/Gp tunnel new complicated logic is required, but the data is delivered only once between the GGSN and the SGSN.~~

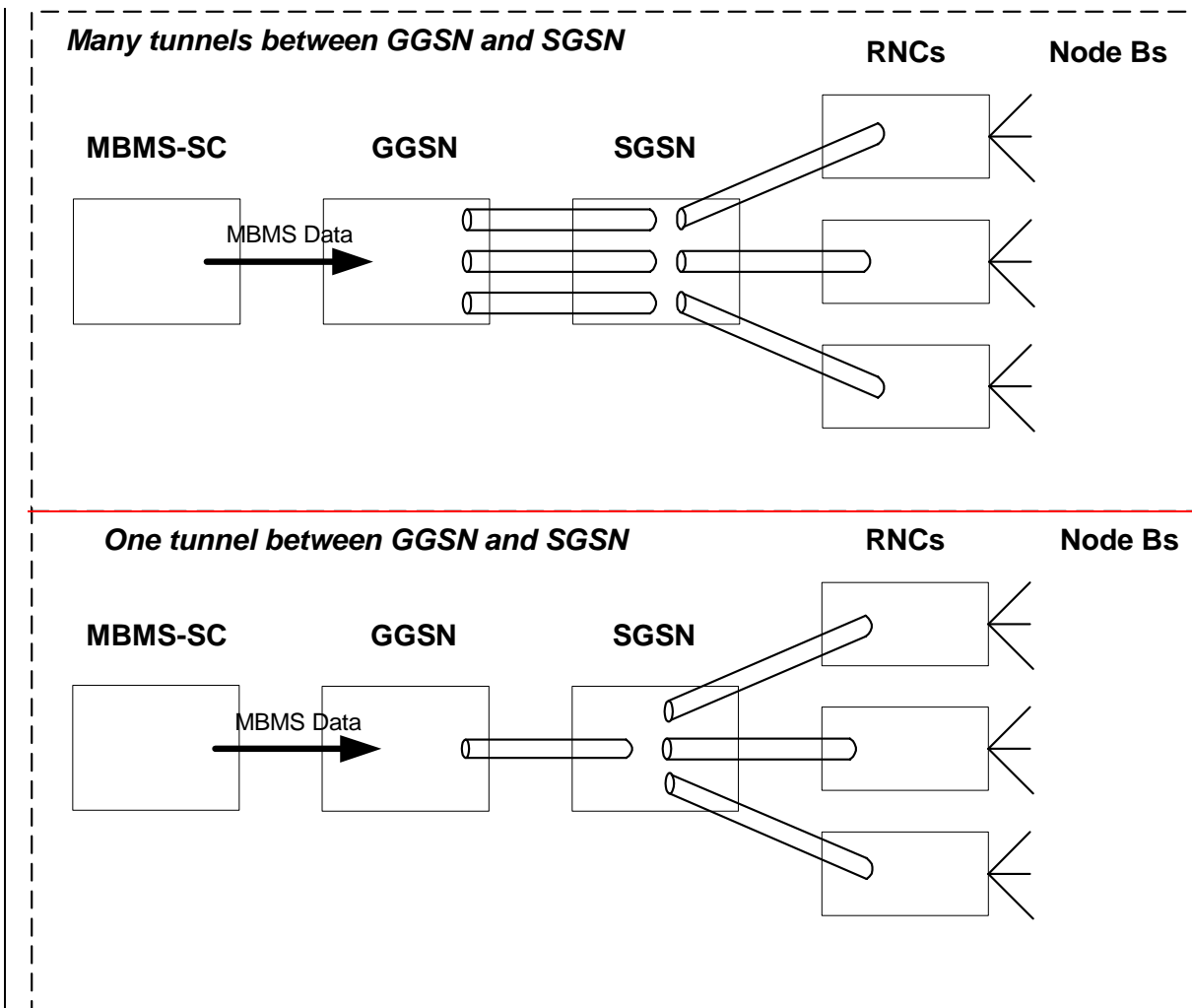

Figure 23. Many tunnels between GGSN and SGSN vs. One tunnel between GGSN and SGSN.

---

# 1 Scope

The present document discusses architectural issues and describes functionalities required for the Multimedia Broadcast/Multicast Service. MBMS requirements are discussed in [2] and it is the intention of this document to present one or more alternatives to achieving the required functionality within 3GPP networks.

---

# 2 References

The following documents contain provisions which, through reference in this text, constitute provisions of the present document.

- References are either specific (identified by date of publication, edition number, version number, etc.) or non-specific.
- For a specific reference, subsequent revisions do not apply.
- For a non-specific reference, the latest version applies. In the case of a reference to a 3GPP document (including a GSM document), a non-specific reference implicitly refers to the latest version of that document in the same Release as the present document.

[1] 3GPP TR 21.905: "3G Vocabulary".

[2] 3GPP TS 22.146: "Multimedia Broadcast/Multicast Service; Stage 1".

[3] IETF RFC 2710 (1999): "Multicast Listener Discovery (MLD) for IPv6"

[4] 3GPP TS 23.107: "QoS Concept and Architecture"

[5] IETF RFC 2327: "SDP: Session Description Protocol"

[6] IETF RFC 2974: "Session Announcement Protocol"

---

# 3 Definitions and abbreviations

## 3.1 Definitions

For the purposes of the present document, the terms and definitions given in [1] and the following apply.

**MBMS Bearer Service:** The network service used to deliver a single multicast data stream to one or more users. A network service is associated with a single data path with an associated QoS profile. Delivery of a single 'MBMS Service' may require multiple MBMS Bearer Services.

**MBMS broadcast activation:** The process which enables the data reception from a specific broadcast mode MBMS on a UE.

**MBMS multicast activation:** The process which enables a UE to receive data from a specific MBMS multicast. Thereby the user joins a specific multicast group. The activation may be performed by the user and it may be performed inherently for subscribed multicast services.

**MBMS Notification:** The mechanism which informs the UEs about a forthcoming (and potentially an ongoing) data transfer from a specific MBMS service

## 3.2 Abbreviations

For the purposes of the present document, the following abbreviations apply:

BM-SC Broadcast Multicast - Service Centre

IGMP Internet Group Management Protocol

MLD Multicast Listener Discovery

MBMS Multimedia Broadcast/Multicast Service

Other abbreviations used in the present document are listed in 3GPP TR 21.905 [1].

---

## 4 Introduction

The MBMS [2] is a point-to-multipoint service in which data is transmitted from a single source entity to multiple users. Transmitting the same data to multiple users allows network resources to be shared.

The MBMS offers two modes:

- Broadcast Mode
- Multicast Mode

---

## 5 High Level Functionality

A short overview

### 5.1 Architecture Principles

In developing and evaluating different architectural options for MBMS, the following principles should be taken as general architectural guidelines that should be followed:

1. MBMS architecture shall enable the efficient usage of radio-network and core-network resources, with the main focus on the radio interface efficiency. Specifically, multiple users should be able to share common resources when receiving identical traffic.
2. The MBMS architecture shall support common features for MBMS multicast and broadcast modes, e.g. both modes shall preferably use the same low-layer bearer for data transport over the radio interface.
3. The MBMS architecture does not describe the means by which the BM-SC obtains the service data. The data source may be external or internal to the PLMN e.g content servers in the fixed IP network, any UE attached to the PLMNMBMS shall support both IP multicast and IP unicast sources.
4. MBMS architecture should re-use, to the extent possible, existing 3GPP network components and protocol elements thus minimizing necessary changes to existing infrastructure and providing a solution based on well-known concepts.
5. MBMS shall be a point-to-multipoint bearer service for IP packets in the PS domain.
6. MBMS shall be interoperable with IETF IP Multicast.
7. MBMS shall support IETF IP Multicast addressing.
8. It shall be possible for UEs to receive MBMS when the terminal is attached.
9. It shall be possible for UEs to receive MBMS data in parallel to other services and signalling (e.g. paging, voice call).
10. MBMS shall support different quality of service levels. The mechanisms for this are for further study, one example is repetitions to all users.
11. MBMS service areas shall be defined per individual service with a per cell granularity.
12. MBMS is not supported in the CS domain.

13. [When the UE is already receiving data of an MBMS service, it shall be possible for the UE to be notified about a forthcoming and potentially about an ongoing data transfer from other MBMS services.](#)
14. [Charging data shall be provided per subscriber for MBMS multicast mode .](#)
15. [The MBMS bearer service concept should contain the decision making process for selection of point-to-point or point-to-multipoint configurations.](#)
16. [The architecture should be able to provide home MBMS multicast services to users when roaming outside their home network as subject to interoperator agreements.](#)
17. [MBMS should be designed to minimise power consumption within the mobile station.](#)
18. [Applications shall be tolerant to packet loss and duplication caused by e.g. UE mobility or transmission loss.](#)
19. [The backwards compatibility of the MBMS service to the R99 IP multicast delivery mechanism shall be considered. Interworking possibilities between MBMS capable network elements and non-MBMS capable network elements \(e.g. interworking with R99 IP Multicast service GGSNs\) shall be described.](#)
20. [The MBMS standard should avoid placing excessive signalling load requirements on the network. In particular, the MBMS standard should permit operators to configure their networks so that when a UE, which is not actually receiving a media stream, changes between GSM and UMTS cells in the same Routeing Area, there is no significant signalling traffic load on the network.](#)

## 5.2 Architectural Overview

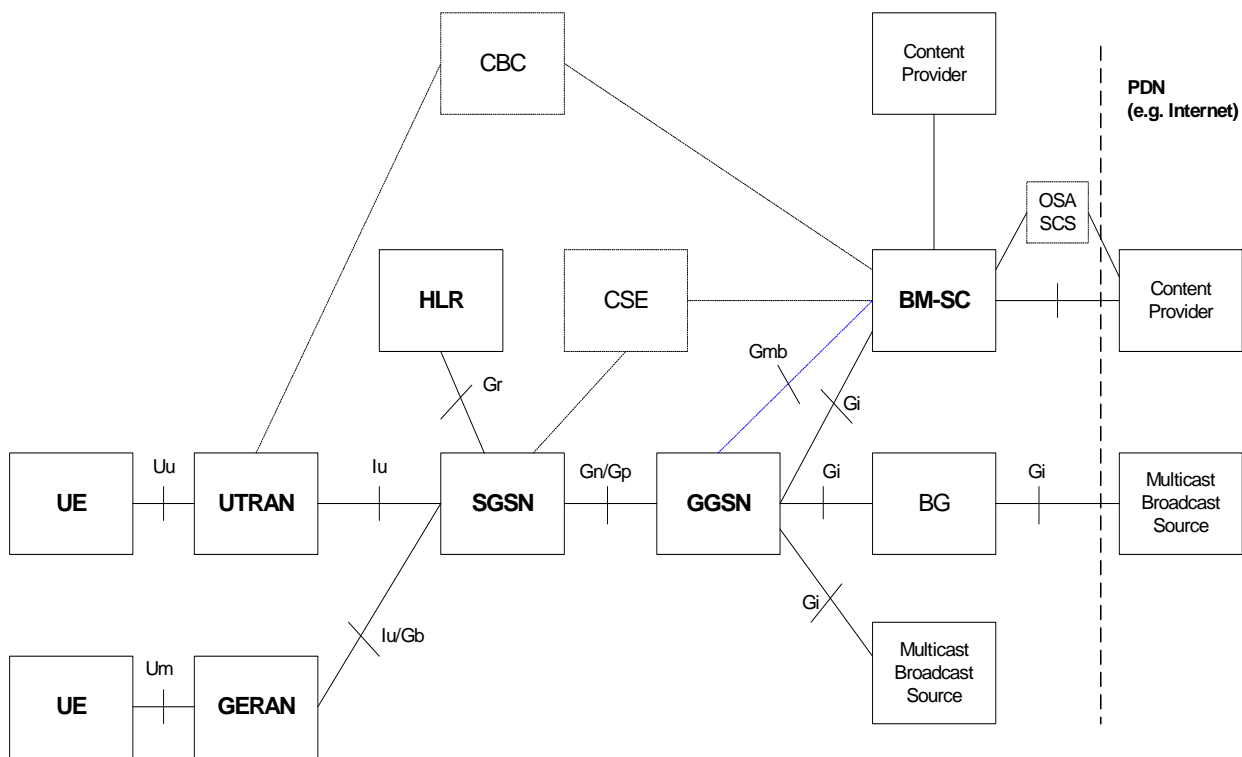

Figure 24. MBMS Architecture

Note: dotted lines means functions / reference points that are optional. Gp applies only when SGSN and GGSN are in different PLMN.

### SGSN

In the MBMS architecture the SGSN performs user individual service control functions and the SGSN concentrates all individual users of the same MBMS service into a single MBMS service. The SGSN maintains a single connection with the source of the MBMS data.

### GGSN

The GGSN terminates the MBMS GTP tunnels from the SGSN and links these tunnels via IP multicast with the MBMS data source.

### BM-SC

The BM-SC is an MBMS data source. MBMS data may be scheduled in the BM-SC, e.g. for transmission to the user every hour. It offers interfaces over that content provider can request data delivery to users. The BM-SC may authorise and charge content provider.

The Gmb reference point between BM-SC and GGSN enables the BM-SC to exchange MBMS service control information with the GGSN. The specification of the Gmb reference point is FFS.

The Gmb reference point exists in order to carry the MBMS Service information but it may not always be necessary to use the Gmb for each service. The possible cases are:

- 1) No real-time interface between GGSN and BM-SC - service information is configured or downloaded to GGSN by some other means
- 2) Real-time interface - no per-user authorisation. BM-SC 'pushes' or GGSN 'pulls' service information from BM-SC on first service activation, but subsequent activations from other users do not require reference to BM-SC.
- 3) Real-time interface - per-user authorisation. GGSN 'pulls' service information from BM-SC for every service activation.
- 4) No interface between GGSN and BM-SC. Service information is configured at GSNs

### MBMS Data Sources

The architecture allows for other MBMS broadcast/multicast data sources. Internal data sources may directly provide their data. Data delivery by external sources is controlled by Border Gateways (BG) which may allow for example data from single addresses and ports to pass into the PLMN for delivery by an MBMS service.

*[Editor's note: BG functions need to be clarified.]*

The architecture assumes the use of IP multicast at the reference point Gi. The MBMS data source has only one connection to the IP backbone. The reference point from the content provider to the BM-SC is not standardised. It might become too complex or too restrictive for service creation. For example, this may be a reference point between the BM-SC and an authoring system, or the authoring functionality may be distributed between both entities.

The same architecture provides MBMS broadcast services mainly by using the transport functions. The user individual SGSN functions are not required. Instead each individual broadcast service is configured in the SGSN.

### Optional Network Elements

The SGSN may use CAMEL to handle pre-paid services, e.g. credit checking for on-line charging.

The Cell Broadcast Centre (CBC) may be used to announce MBMS services to the users. How this is accomplished is FFS.



The BM-SC might use OSA-SCS to interact with third parties.

Note: For the terminal split case, MBMS shall be able to interoperate with an IP multicast client software on the TE. The mechanism for this interoperability is FFS.

## 5.3 MBMS Reference Points

Gmb reference point

The Gmb reference point is between the BM-SC and the GGSN. It is used to give MBMS service information, like QoS and MBMS service area, to the UMTS network.

## 5.4 High Level Functions

Multimedia Broadcast/Multicast Service is associated with several logical functions that should be provided by the network.

### 5.4.1 Authentication and Authorization

#### 5.4.1.1 Content Provider Authentication and Authorization

- MBMS should be able to identify and authenticate the content provider prior to receiving control or data from it.
- A content provider may request to provide a multicast or broadcast service using MBMS possibly stating desired QoS, geographical areas and other service-related parameters. MBMS shall be able to authorize this service provision with the requested parameters prior to service initiation.

#### 5.4.1.2 User Authentication and Authorization

- MBMS shall be able to authenticate and authorize users before joining to multicast groups (i.e. receive MBMS multicast services).

### 5.4.2 Efficient Routing and Resource Usage

- The MBMS shall be able to efficiently route multicast and broadcast over the radio interface and within the radio network. Efficient routing within the core-network is desired as well.
- In Multicast mode, MBMS should support multicast resource allocation where-by data transmission to a multicast group is carried out in certain cell only if multicast group members are to be found in that cell.
- Hierarchically structured networks can provide coverage for a given location using multiple carrying frequencies or multiple cells of varying sizes. Provisioning and efficient delivery of MBMS services within hierarchical network architectures should be considered.

### 5.4.3 Mobility Management and Service Continuity

- MBMS shall support service continuity when moving from cell to cell within the multicast/broadcast area.

NOTE: Loss of data may occur during this process.

- MBMS should enable roaming users to receive both home and local multicast services. Roaming users should be able to receive local broadcast services as well.

#### 5.4.4 Service Initiation and Termination

- The UE shall be able to enable and disable broadcast service reception.
- The UE shall be able to join and leave multicast groups. Roaming users should be able to join and leave multicast groups in the home or visited network.

#### 5.4.5 Charging

MBMS shall collect charging information about the delivery of MBMS broadcast or multicast data that are provided by content or service providers (e.g. 3<sup>rd</sup> parties). This shall enable billing of broadcast and multicast content or service providers. This charging information may include duration of service usage, volume of MBMS data, MBMS service area.

MBMS shall collect charging information about the usage of MBMS multicast services by individual users/receivers. This charging information may include duration of service usage, volume of MBMS data, time when joining or leaving a multicast group.

#### 5.4.6 Security

- To prevent unauthorized reception of multicast data, multicast transmission may be secured.
- To prevent injection of malicious content into the network MBMS should be able to authenticate the content provider and verify the integrity of the data received from the content provider.
- It is required that a USIM is present in the UE to receive MBMS services.
- See also clause “Authentication and Authorization“

##### 5.4.6.1 Constraints for MBMS ciphering key use

The ciphering key management for MBMS faces the following constraints:

- There is a need to change the MBMS ciphering key as some UE can leave a MBMS session or their subscription to a MBMS service can be removed in order to forbid them to listen to the MBMS data still distributed for other users.
- The new key have to be provided to the remaining users. It appears not probable that each UE in the entire MBMS distribution tree get the new key at the same instant. So that the key has to be distributed before it is used and the trigger to determine when the key will be used has to be known by the users. Until the new key can be used, the user have to use the old key with which the MBMS data are ciphered.
- To provide the key individually to each authorized user. It is seen as reasonable to avoid to provide simultaneously the key established for all the users present in a cell at the same time.

###### 5.4.6.1.1 Proposal 1 for a ciphering key use principle

It is proposed to use an odd & even key principle. With this principle:

- 2 keys will be made available in each UE: the “current key” and the “next key” to be used.
- The change of key for data ciphering will occur and the trigger has to be known by each UEs that activated the service. At each trigger, the “current key” is not more used to encrypt/decrypt the MBMS data and the “next key” becomes the “current key”.
- Definition of the trigger is FFS
- Each UE has to get the “next key” before the trigger that un-validate the “current key” occurs

- A smooth distribution of the key is provided as each UE can initiates this key request independently.

The procedure used by the UE to get the “next key” and the entity that provide the key remain FFS.

#### 5.4.7 Addressing

#### 5.4.8 Roaming

## 5.4.9 MBMS Service Provision Phases

### 5.4.9.1 MBMS broadcast service provision phases

An example for the phases of MBMS broadcast service provision is described in the figure below.

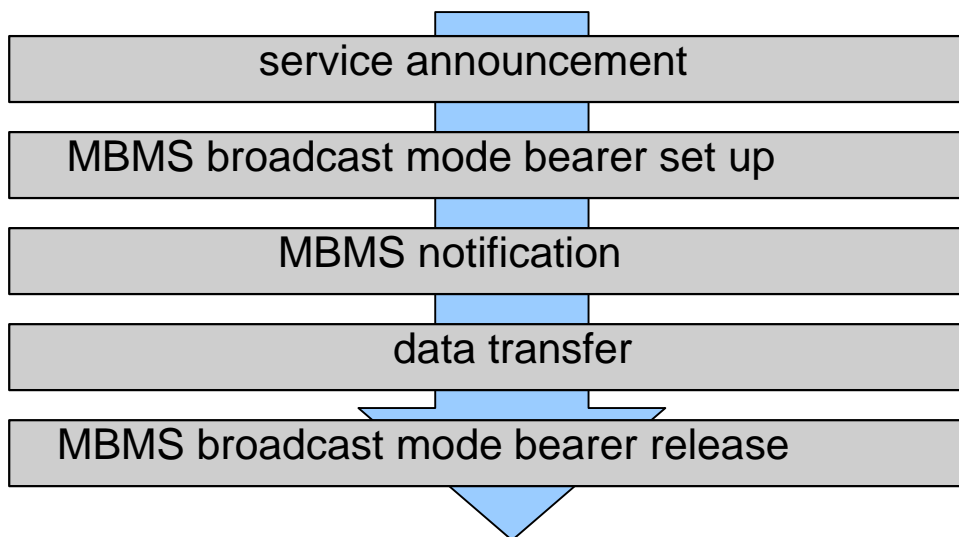

Fig. 25: Phases of MBMS broadcast service provision

**Service announcement** informs UEs about forthcoming services.

**MBMS broadcast mode bearer set up** establishes the network resources for MBMS data transfer in the broadcast area.

**MBMS notification** informs the UEs about forthcoming (and potentially about ongoing) broadcast data transfer.

**Data transfer** is the phase when MBMS data are transferred to the UEs.

**MBMS broadcast mode bearer release** releases the network resources for MBMS data transfer, e.g. when no more MBMS data have to be transferred.

The sequence of phases may repeat, e.g. depending on the need to transfer data. It is also possible that the service announcement and MBMS notification phase may run in parallel with other phases, in order to inform UEs which have not yet received the related service.

### 5.4.9.2 MBMS multicast service provision phases

[An example for the phases of MBMS multicast service provision is described in the figure below.](#)

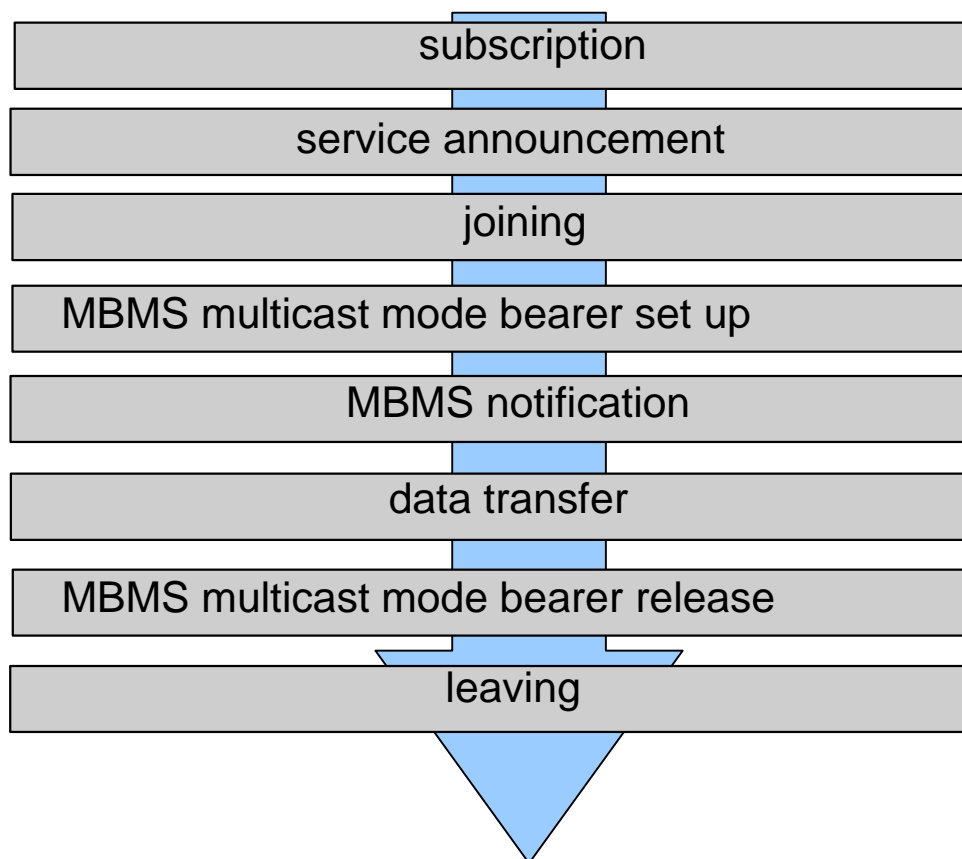

[Fig. 26 Phases of MBMS multicast service provision](#)

[\*\*Subscription\*\* establishes the relationship between the user and the service provider, which allows the user to receive the related MBMS multicast service](#)

[\*\*Service announcement\*\* informs UEs about forthcoming services.](#)

[\*\*Joining\*\* \(MBMS multicast activation\) is the process by which a subscriber joins \(becomes a member\) a multicast group, i.e. the user indicates to the network that he/she is willing to receive Multicast mode data of a specific service.](#)

[\*\*MBMS multicast mode bearer set up\*\* establishes the network resources for MBMS data transfer in the multicast area.](#)

[\*\*MBMS notification\*\* informs the UEs about forthcoming \(and potentially about ongoing\) multicast data transfer.](#)

[\*\*Data transfer\*\* is the phase when MBMS data are transferred to the UEs.](#)

[\*\*MBMS broadcast mode bearer release\*\* releases the network resources for MBMS data transfer, e.g. when no more MBMS data have to be transferred.](#)

[\*\*Leaving\*\* \(MBMS multicast deactivation\) is the process by which a subscriber leaves \(stops being a member\) a multicast group, i.e. the user no longer wants to receive Multicast mode data of a specific service.](#)

[The phases subscription, joining and leaving are performed individually per user. The other phases are performed for a service, i.e. for all users interested in the related service. The sequence of phases may repeat, e.g. depending on the need to transfer data. Also subscription, joining, leaving, service announcement as well as MBMS notification may run in parallel to other phases.](#)

---

## [6 Functions and Entities](#)

[More detailed description of functions, discussion of options for functions, description of network entities.](#)

## 6.1 UTRAN/GERAN Functionality

- The RAN shall deliver the MBMS service over at least the broadcast or multicast service area. The served area might be larger than the multicast or broadcast area, e.g. when the multicast or broadcast area does not exactly map onto cell or LA borders of the UTRAN.
- The RAN may establish point to multipoint channels at the air interface without any required uplink radio signaling from the UE(s) for broadcast mode

### 6.1.1 Broadcast Mode

### 6.1.2 Multicast Mode

The radio access network (UTRAN/GERAN) shall provide the following functionality for efficient support of MBMS

- responsible for establishment of point to multipoint or point to point channels on the air interface to support MBMS.
- capable of routing MBMS traffic over either a point to multipoint channel or over a point to point channel.
- capable of discovering the number of MBMS users within a cell
- makes the decision to select channel type (point to multipoint or point to point) based on the number of users within a cell receiving MBMS service. The threshold value for this is operator defined

The design of and the decision on resource efficient RAN functionality are subject to TSG RAN.

## 6.2 SGSN Functions

A number of functions provided by the SGSN for ptp bearer services may be used to provide MBMS:

- The SGSN authenticates users based on subscription data from HLR
- The SGSN authorises the usage of services/resources based on subscription data from HLR
- The SGSN provides user individual service control (ptp services)
- The SGSN provides user individual mobility management
- The SGSN may limit the service area per individual user
- The SGSN stores contexts per activated service per individual user
- The SGSN generates charging data per service for each user
- The SGSN provides CAMEL functions (e.g. prepaid)
- The SGSN establishes RABs on demand when data has to be transferred to the users

All these functions may be used in an MBMS architecture (potentially with modifications) for user individual control of MBMS multicast services, i.e. to activate, deactivate, authorise, ... the MBMS services for individual users. The mechanisms for provision of RABs on demand when data is to transfer may need extensions to provide shared resources for MBMS.

## 6.3 GGSN functions

The functions a GGSN could provide for MBMS are:

- Message Screening
- Charging Data Collection

- Mobility management
- Tunnelling of data
- Service (QoS) negotiation
- Policing

Message screening is not needed if the MBMS sources are internal in the PLMN or it is provided by the BM-SC or the BG which are gateways to external MBMS data sources.

Charging data may be collected for the MBMS data sources. But, the potential existing sources like ESS or MMS provide charging information and very likely also the BM-SC. User individual charging information is collected by the SGSN. It is not favourable to keep user individual contexts per multicast service in the SGSN and in the GGSN in parallel under the assumption that such user individual contexts are stored as long as the user is attached.

The mobility management of the GGSN can not support MBMS as the GTP tunnels would be fixed. These tunnels are used by multiple UEs in parallel and can not move with UEs.

The tunnelling seems the most important GGSN function for MBMS. It allows the provision of HPLMN MBMS multicast services to users roaming in a VPLMN. The tunnelling separates the traffic of the different MBMS services from each other and allows therefore the use of the same addresses in HPLMN and VPLMN. A co-ordination of addresses between different PLMNs is not needed.

A GGSN could simplify O&M when used to provide the parameters for the individual MBMS services at the service negotiation when the GTP tunnels are established. This approach has limitation when different configurations are required for the same service (potentially one SGSN has to provide different MBMS data for the same service in different areas, e.g. regional news). Then it has to be configured differently on the SGSN. Also the broadcast service needs to be configured on the SGSN, as there is no signalling with UEs which could trigger a tunnel establishment between SGSN and GGSN.

The GGSN could police the traffic of the individual MBMS services. But, most MBMS data sources are allocated within the PLMN and therefore under control of the operator. In addition, the QoS profile is very likely configured on the SGSN. And, the RAB will limit the possible throughput to the maximum bitrate and inherently police the traffic.

Most of the GGSN functions described above do not add any functionality useful for MBMS. Only for provision of HPLMN MBMS services to roaming users a GGSN is added to the architecture. The same approach is used for provision of MBMS services within one PLMN to avoid two different architectures.

## 6.4 UE functions

- After activation of a MBMS service, the UE shall be able to receive MBMS data without explicit user request.
- UEs, which store MBMS data, may have functionality for Digital Rights Management.
- The UE shall be able to receive indications for other services e.g. paging in CS. However, this may create losses for which the MBMS applications shall cope with.
- The UE shall allow reception of MBMS service announcements while receiving MBMS data.
- The UE shall provide the functions to activate/deactivate MBMS data reception.
- The UE should support security functions for the provision of MBMS service.

### 6.4.1 UE Functional Split Considerations

With the aim of enabling UE borne applications to use MBMS in receiving broadcast or multicast transmissions, the UE shall offer the following functions to applications:

- TE request to perform MBMS broadcast activation for a given broadcast service and to receive service related data.

- TE request to perform MBMS multicast activation (join) for a given multicast service and to receive service related data.
- TE request to perform MBMS broadcast deactivation for an activated broadcast service and to cease service-related data reception.
- TE request to perform MBMS multicast deactivation for an activated multicast service and to cease service related data reception.

Note: For broadcast activation and deactivation, it is assumed that no signalling between UE and network is necessary.

## 6.5 Other MBMS functions

Besides the user individual service control functions comparable to the functions already provided by an SGSN or GGSN there are some additional functions required for MBMS, mainly the specific data transport. It is assumed, that the SGSN performs the user individual service control, generates the charging data per user and establishes the RABs when MBMS data is to be transferred. The SGSN concentrates all user individual services into one MBMS service for each specific MBMS service. This includes the establishment of a number of RABs to transfer MBMS data to the radio network entities of the related service area and it includes a single connection between the SGSN and the GGSN for each individual MBMS service.

## 6.6 MBMS Context

The entities of the PLMN that provide MBMS services maintain one or more MBMS contexts for each active MBMS service. An MBMS context contains information and parameters necessary for each MBMS service. An MBMS context contains among others the PDP address, which is the IP address of the MBMS service (IP Multicast address), and the APN used to access the MBMS service. The combination of the PDP address and the APN uniquely identify the MBMS service. Other content of the MBMS context is FFS. It is FFS whether PLMN entities maintain service specific MBMS contexts per UE, per network entity, or both.

## 6.7 BM-SC functions

BM-SC should provide the following functions for MBMS:

- Authorization and authentication of content providers.
- Verify integrity of data received from content provider.
- Determine quality-of-service for MBMS transmissions (within operator configured QoS bounds).
- MBMS data repetition and error resilient schemes to cope with possible transmission loss.
- Content provider charging.

Further the BM-SC

- shall support functions to allow a content provider to select from operator defined broadcast or multicast areas for a MBMS service.
- shall be able to support several MBMS services taking into account their respective delivery constraints.
- shall provide functions to produce service announcements for the UE. The service announcement may include information about the required UE capabilities.
- shall provide functions to schedule MBMS data.
- shall be able to support one or more service providers



## 6.8 CBC functions

The Cell Broadcast Centre (CBC) may be used to announce MBMS services to the users. The functions a CBC could provide for MBMS service announcement are FFS.

## 6.9 MBMS Data Transfer in the Core Network

Multicast data must be available at the RNCs to be sent over the radio. The options for the data path are to send multicast data from a multicast "source" (could be a multicast server or multicast capable node) to:

1. all RNCs
2. only selected RNCs which have multicast users.
3. all SGSNs to be further distributed by the SGSN to the RNCs, or
4. selected SGSNs which have multicast users to be further distributed by the SGSN to the RNCs,  
or
5. selected GGSN which support multicast service (possibly identified using APNs) and to be further distributed from the GGSN towards the RNCs.

The first option is wasteful of network resources and also makes it difficult to send data to VPLMNs for roaming users. The second option, an optimisation of the first one, is to send data only to RNCs with multicast users within the PLMN under control of the activation centre but this cannot support roaming users either. Handling user mobility is also an issue here if for example the UE is in PMM idle.

Sending data to the GGSN in the last option is a good choice to support roaming users. The data is then multicast to the SGSNs with registered multicast users. Sending data through the SGSN – either directly (the third option) or via the GGSN (the last option) – has advantages since the SGSN is aware of the user location information even in PMM idle state but the use of Iu-flex introduces complexities. Each SGSN node may use the routing area update procedure to help determine whether a multicast group user exists within its service area.

A combination of the above listed options can also be used – with direct transfer to RNC for the home users and via the GGSN to the roaming user.

The protocol to use to send data to the RNC or SGSN (if they are the recipient NE as per options discussed above) could be GTP or using IP multicast. Using IP multicast would be more efficient over the transport network if it supports multicast routers

Where the option to optimise and send data only to selected NEs is chosen, a signalling mechanism must be used to identify the appropriate nodes to set up the data path. If the data path is through the SGSN and GGSN, signalling similar to the existing GTP-C can be used to set up the tunnels. If IP multicast is used, the NEs wanting to receive multicast data, such as RNC or GGSN that have multicast users, could indicate its inclusion using IGMP/MLD.

The selection of an option is FFS.

### 6.9.1 Use of IP Unicast on Iu and Gn

In case of use of IP unicast on Iu and Gn:

- The GGSN duplicates the packets received from the MBMS data source for forwarding to each SGSN to which a GTP tunnel is established for a specific MBMS service.
- The SGSN duplicates the packets received from the GGSN for forwarding to each RNC involved in provision of a specific MBMS service.
- The figure below shows the use of IP-unicast to optimise the user-plane on the Gn interface. It is possible to use a single user-plane connection to each SGSN.

A similar discussion applies to the Iu interface.

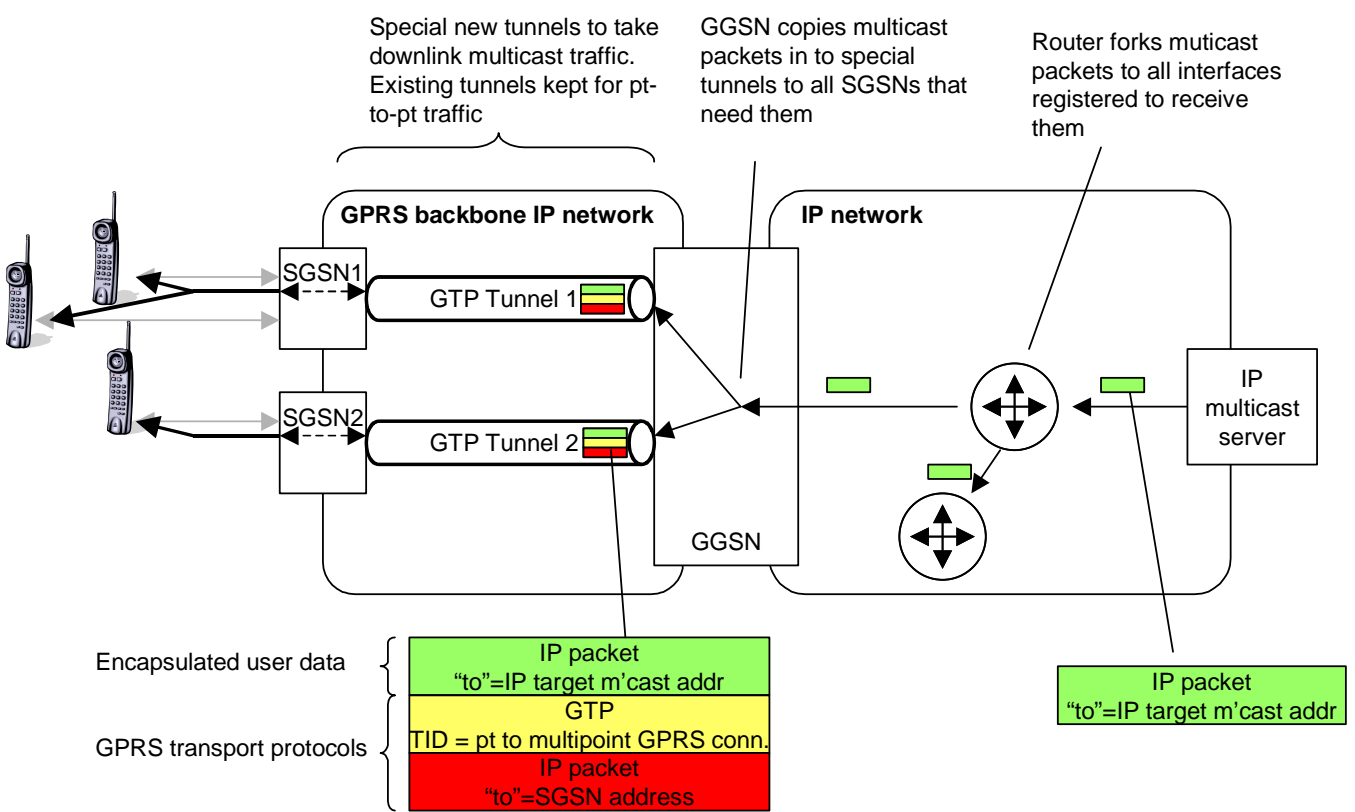

Figure 27: Optimised User Plane connections using IP unicast on the Gn interface

### 6.9.2 Use of IP Multicast on Iu and Gn

An alternative optimisation is to use special IP multicast groups within the GPRS backbone to transport data on the Gn interface. Instead of unicasting data to each individual SGSN, the GGSN only needs to forward packets once addressed to a specific multicast group. All SGSNs that need to receive this data can then register to receive the multicast group. Forking will be done by IP routers (assuming that multicast is supported).

A similar discussion applies to the Iu interface.

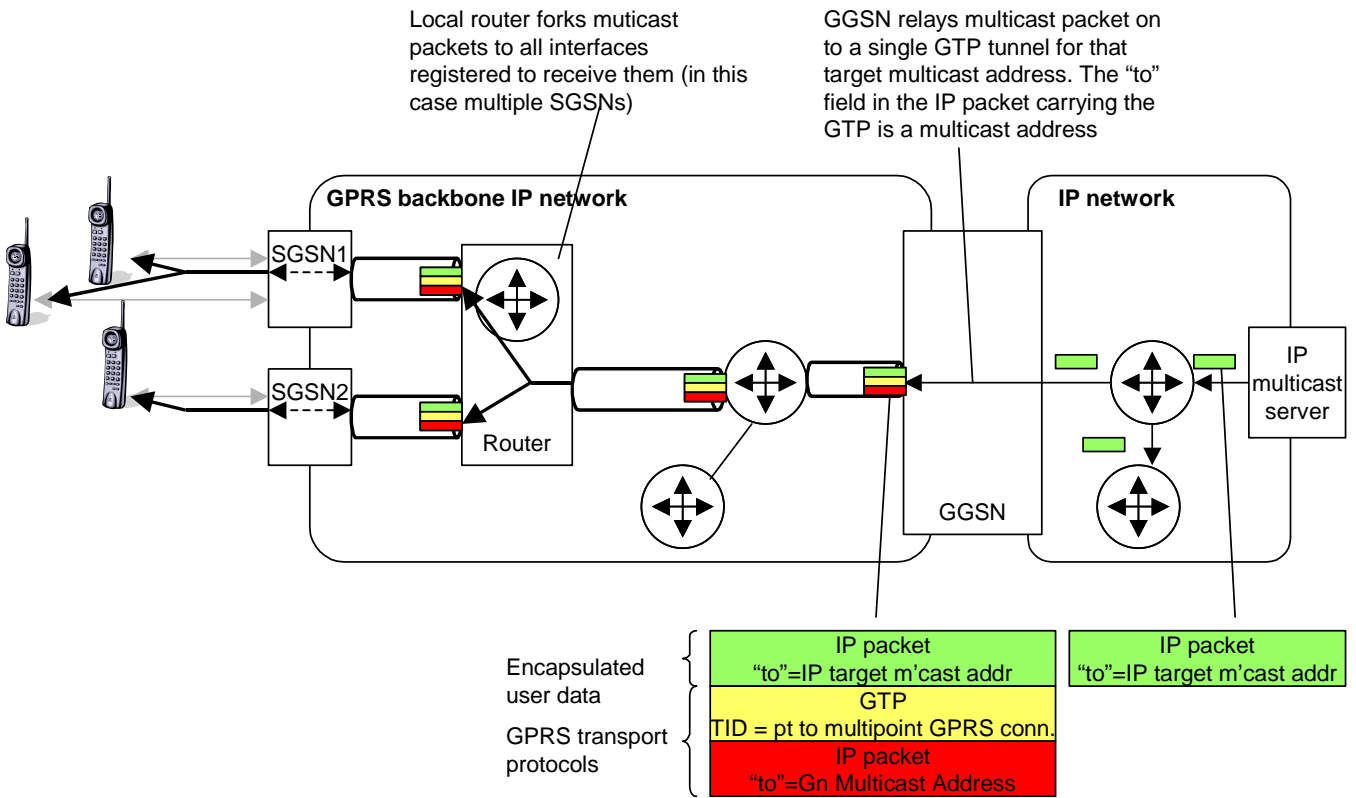

Figure 28: Optimised User Plane connections using IP multicast on the Gn interface

### 6.9.2.1 Example Activation Procedure on Gn

The following diagram shows an example activation procedure on Gn if IP multicast transport is used. Associated Iu procedures are now shown.

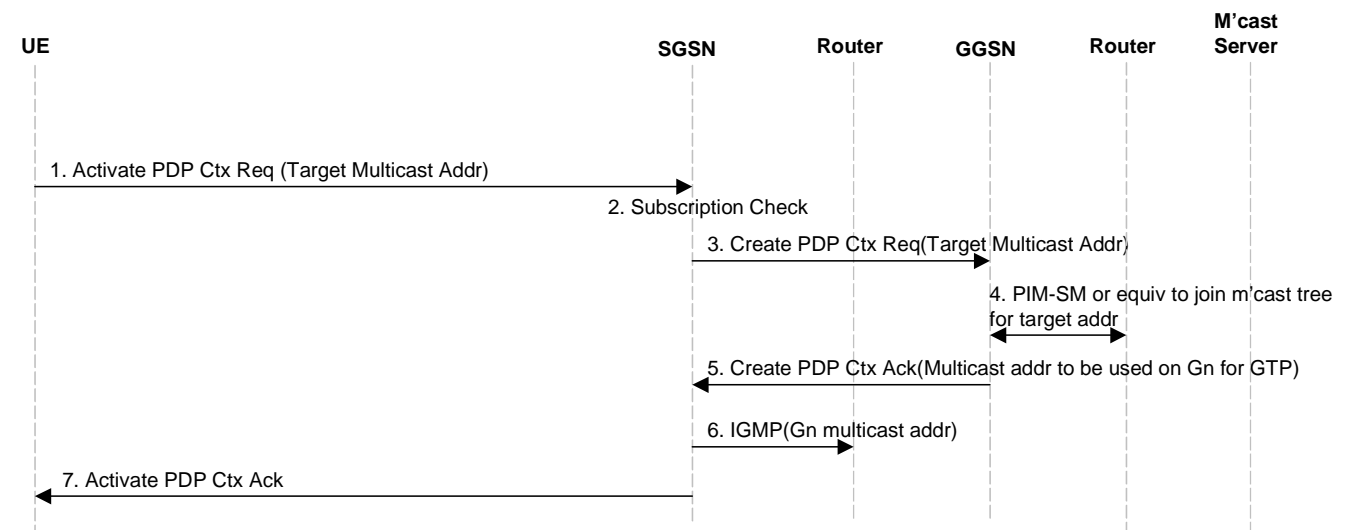

Figure 29 - Example activation procedure

- 1 A PDP context is established to receive multicast packets sent to the Target IP Multicast Address.
- 2 The SGSN may perform a subscription check.
- 3 The SGSN requests the GGSN to receive packets from the target multicast address.

- 4 If the GGSN is not already registered to receive multicast packets sent to the Target IP Multicast Address it registers with its peer router.
- 5 The GGSN acknowledges the request. It provides the SGSN with the GTP TID (GPRS Tunneling Protocol Transaction ID) that will be used for the multicast tunnel and also the IP multicast address it will use to send the GTP packets on the Gn interface. The IP multicast address for the GTP tunnel should be chosen from a pool managed by the GGSN.
- 6 If the SGSN is not already registered to receive multicast packets sent to the Gn IP Multicast Address, it registers with its adjacent router
- 7 The SGSN passes back to the mobile an acknowledgement

### 6.9.3 Comparison with requirements

<u>Criteria</u>	<u>Unicast solution</u>	<u>Multicast Solution</u>
<u>Data distribution</u>	<u>GGSN must fork data to all SGSNs containing active subscribers to the MBMS group. Each data stream must travel the whole network between the GGSN and the SGSN in parallel.</u>  <u>No impact on addressing at Gn level.</u>  <u>Home and visited networks must both support MBMS</u>	<u>GGSN sends data once to all SGSNs. Intermediate routers fork the data as required. It is possible to design the network topology so that the forking will take place near the endpoint.</u>  <u>Use of multicast addresses at Gn must be coordinated between network operators.</u>  <u>Home and visited networks must both support MBMS</u>
<u>Efficient implementation in GGSN</u>	<u>Either, Control Plane procedures modified to be per service, or, change in GTP-C to GTP-U relationship.</u>	<u>Change in GTP-C to GTP-U relationship, plus: IP multicast must be supported on Gn.</u>  <u>Multicast tunnels keyed on multicast address, not TEID.</u>
<u>Efficient implementation in SGSN</u>	<u>Either, Control Plane procedures modified to be per service, or, change in GTP-C to GTP-U relationship.</u>	<u>Change in GTP-C to GTP-U relationship, plus: IP multicast must be supported on Gn and Iu.</u>  <u>Multicast tunnels identified by multicast address, not TEID.</u>
<u>Efficient implementation in RNC</u>	<u>Either, Control Plane procedures modified to be per service, or, change in GTP-C to GTP-U relationship</u>	<u>Change in GTP-C to GTP-U relationship, plus: IP multicast must be supported on Iu.</u>  <u>Multicast tunnels identified by multicast address, not TEID.</u>
<u>Efficient use of GGSN user plane capacity</u>	<u>GGSN capacity will be consumed for each SGSN added to the multicast group.<sup>1</sup></u>	<u>GGSN capacity will vary little with the number of SGSNs added to the multicast group.</u>
<u>Efficient use of SGSN user plane capacity</u>	<u>SGSN capacity will be consumed for each RNC added to the multicast group.<sup>1</sup></u>	<u>SGSN capacity will vary little with the number of RNC added to the multicast group.</u>
<u>Scalability</u>	<u>Scalability limited by SGSN/GGSN capacity<sup>1</sup></u>	<u>Highly scalable</u>

Note 1: In practice this may not be a major limitation.

## 6.10 Bearer Path

### 6.10.1 Iur Issues

The following Iur issues are specifically for MBMS multicast mode.

The figure below shows a UE being served over Iur through a DRNC. Two possible data paths exist for this UE.

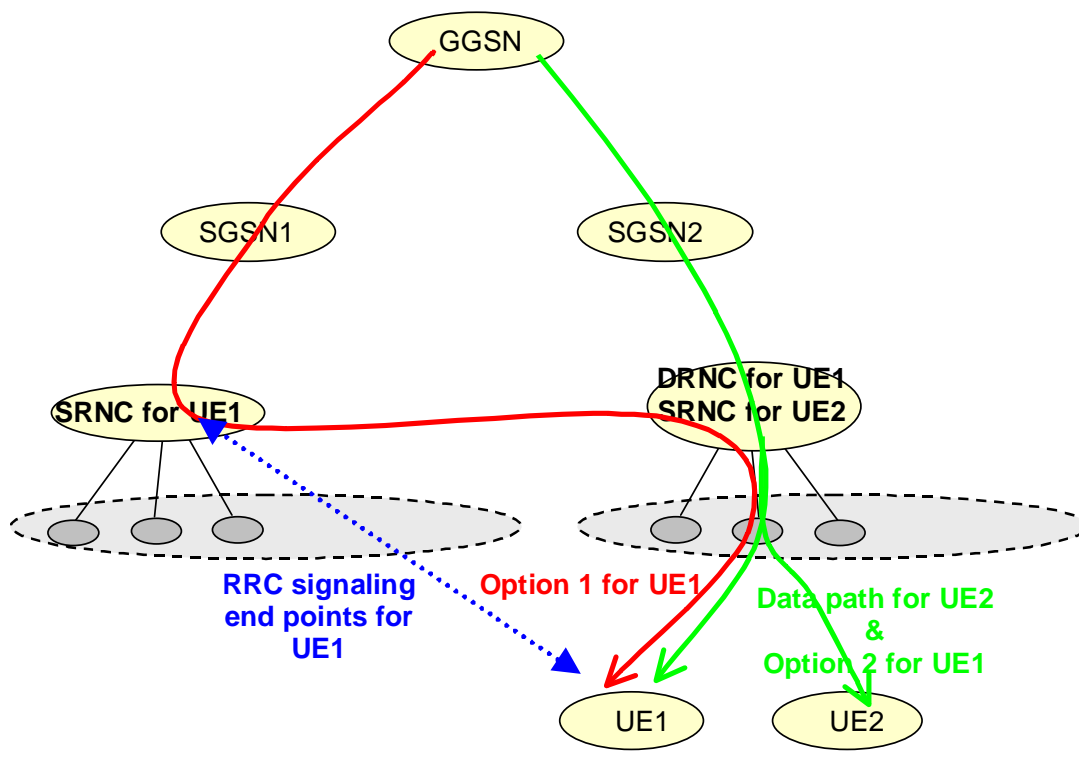

**Figure 30:** The two possible options for data path for UE1 which is served by DRNC. Option 1 is via the SRNC. Option 2 is via a DRNC; note that the DRNC for UE1 could be serving another UE2 as a SRNC and the same data feeds both UE1 and UE2.

**Data path option 1)** Via the SRNC, Iur and DRNC. Because of the mix of multicast users in the cell, the CRNC is sometimes acting as a DRNC and sometimes as a SRNC. The RRC signalling for UE1 is terminated at its SRNC. The RNC could pick between the two flows – over Iur or Iu; however, as users move around/activate/deactivate the service, the RNC will dynamically have to change the selection.

**Data path option 2)** The RNC receives data directly over Iu for all users in the controlled cells, i.e., for users which it is serving as an SRNC and DRNC. Note that the DRNC may already be serving UEs for which it is the SRNC.

The radio channel configuration of the multicast channel and cipher keys (if ciphering is done in the RAN which is still FFS) would need to be signalled to the UE. Again, two possible solutions exist for the signalling of this information between the RAN and UE. These are:

**Signalling option 1)** between the SRNC and UE using dedicated point to point RRC signalling

**Signalling option 2)** defining a new multicast signalling channel between the CRNC and UE. (Note: Multicast signalling channel is also motivated by need to signal to users when the cell changes between PTP to PTM bearer configurations.) This will reduce some of the signalling complexity in Data option 2.

### 6.10.1.1 Impact on R99 Architecture and interaction with Iu-flex

Data path Option 1 is not as significant a departure from R99 architecture as data path option 2. In Option 1 the data path for a UE does not differ from that for any R99 data path, while for Option 2 the data path will not transit the SRNC which is not possible in R99 architecture. In Option 1 the DRNC may have to coordinate between the two flows.

Signalling path Option 1 is not as significant a departure from R99 architecture as signalling path option 2. In Option 1 the signalling path remains as in R99, while in Option 2 the signalling path is via a new signalling channel between the CRNC and UE. In option 2 the signalling and data path from the UE are terminated in the same RNC.

The Iur issue and Iu-flex issue should be studied together since they both have impact on choice of bearer path and thus may have an interaction.

### 6.10.2 Intra Domain Connection of RAN Nodes to Multiple CN Nodes (Iu-Flex)

Iu-flex brings some complications to the multicast architecture. Iu-flex allows users on the same RNC to be registered in different SGSNs. Hence following the normal method of user plane using the same SGSN as the user is registered in could result in multiple streams to the RNC.

If Iu-Flex is employed, it is possible for users within a multicast group to be served by the same RNC but different SGSN. In this situation some of the MBMS IE must be the same even though different SGSNs may be involved.

It is FFS how this is done but the following solutions could be considered:

- a) These IE can be assigned by the same network element
- b) A consistent rule is applied unlike the random generation as used in the TMSI
- c) Synchronisation between different SGSNs.

The following option is the current working assumption for Iu Flexibility: the RNC is permitted to receive multiple streams. It then decides to take only one of the streams.

Every SGSN can request an RNC to establish a multicast RAB as a normal operation. When an RNC detects multiple SGSNs requesting to establish a multicast RAB for the same service, the RNC establishes a multicast RAB with one or more of these SGSNs. How many RABs are needed is FFS. The RNC selects one of the RABs as the source for the multicast data. The selection may be random or according to one or more metrics such as QoS abilities, quality of transfer link, capability of transfer link, etc. Any data that is received on the unselected RABs will be dropped by the RNC. (Note: Whether or not it is necessary to reduce the redundant traffic on the unselected RABs is FFS.) During MBMS data transmission, the RNC may change the selected RAB to achieve better QoS, etc. If some problems occur with the selected RAB or the selected RAB is released or broken, then based on the requirement of the capacity of the interface or some other rationale, one of the other RABs can be selected immediately. All SGSNs receive the MBMS multicast data from the GGSN and may generate volume-charging information for attached UEs.

In order to allow save of resources over Iu and over Gn interfaces, share of user plane is possible between a SGSN and a RNC and between a SGSN and a GGSN to transport data for all UEs activating the same MBMS service.

It is FFS whether there are as many Iu Control plane as UE activating the service in each SGSN (Figure 31) or one control plane for each shared resource (Figure 32).

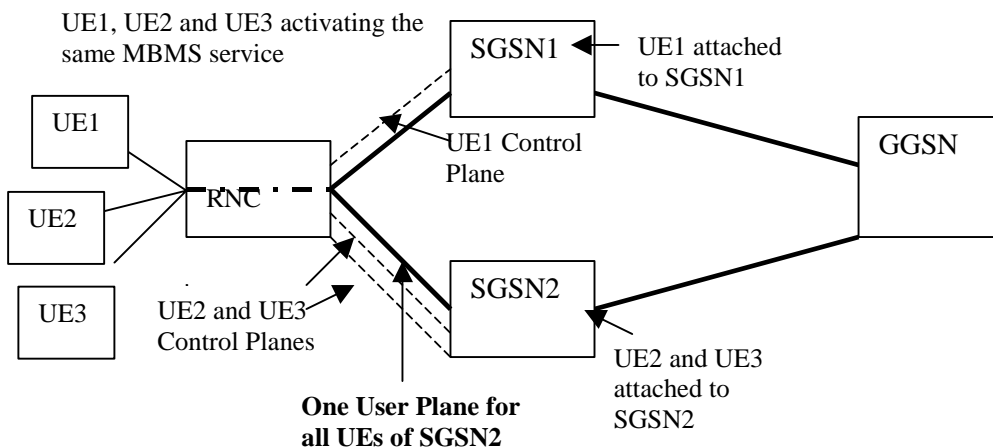

Figure 31

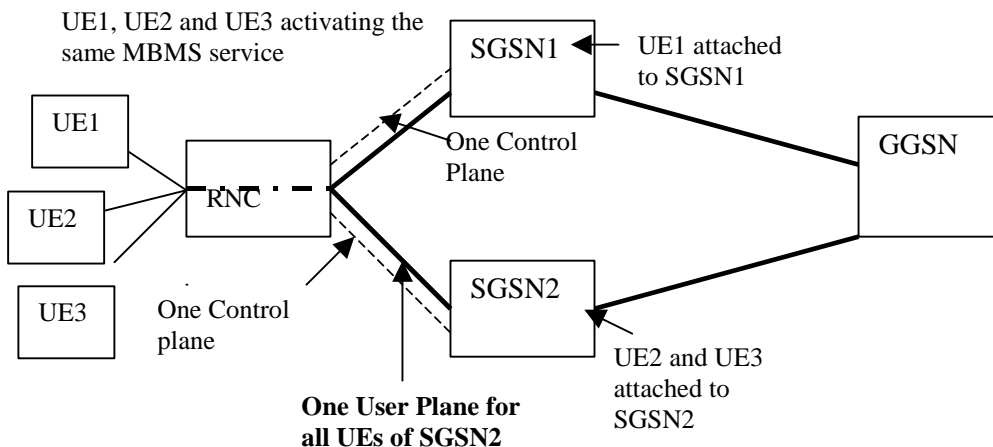

Figure 32

[Other options for dealing with Iu-flex were discussed and can be found in an annex attached at the end of this document.](#)

[How this option deals with Iur, where the data is supplied by the CRNC is FFS.](#)

## 6.11 Packet Temporary Mobile Group Identity in MBMS

[In order to avoid congestion of the paging channels \(at least in GSM\), one solution is to allocate one common identity to all members of each multicast group, which are served by the same SGSN. This Temporary Mobile Group Identity \(TMGI\) could be allocated during a Routing Area Update, a GPRS Attach or a P-TMSI Reallocation procedure before the MBMS data transfer \(e.g. the first TMGI allocation might occur when the mobile joins the IP multicast group\). Separate multicast groups have different TMGIs. TMGIs may also be used to notify users of broadcast transmissions. It is FFS whether the same TMGIs can be used in more than one SGSN.](#)

## 6.12 Decision process for selection of point-to-point or point-to-multipoint configuration

### 6.12.1 Multicast Mode

To ensure that radio resources are not wasted, the radio network needs to estimate the number of users in a cell in order to determine whether to establish a point to multipoint channel in that cell or point to point channels to each user. The radio network shall have the possibility to establish point-to-point channels in case there are a number of UE for a MBMS service in one cell, below a threshold to be specified.

In the event of the number of users within a cell exceeding an operator defined threshold, the radio network will establish a point to multipoint channel in that cell.

If a point to multipoint channel has been established and the number of users drops below an operator defined value then the radio network may be required to drop back to point to point channels.

Note: The two thresholds may be different.

It is FFS whether this change of channel can occur whilst data is being broadcast/multicast.

Input to the threshold determination process is not solely the number of UE for a MBMS service in a given cell, but may include radio resource specific aspects. Which parameters are included in the decision process is FFS and to be decided in 3GPP RAN groups.

The decision process to use point-to-point or point-to-multipoint channels is determined in 3GPP RAN groups and FFS.

The design of and the decision on resource efficient RAN functionality are subject to TSG RAN.

## 6.13 Service Announcement/Discovery

MBMS service announcement/discovery mechanisms should allow users to request or be informed about the range of MBMS services available. This includes operator specific MBMS services as well as services from content providers outside of the PLMN.

Operators/service providers may consider several service discovery mechanisms. This could include standard mechanisms such as SMS, or depending on the capability of the terminal, applications that encourage user interrogation. The method chosen to inform users about MBMS services may have to account for the users location, (e.g. current cell, in the HPLMN or VPLMN). Users who have not already subscribed to a MBMS service should also be able to discover MBMS services.

The following could be considered useful for MBMS service discovery mechanisms (not exhaustive): -

- SMS -CB
- MBMS Broadcast mode to advertise MBMS Multicast Services
- PUSH mechanism (WAP, SMS-PP)
- Web URL

## 6.14 Quality-of-Service

It shall be possible for the network to control quality-of-service parameters for multicast and broadcast sessions. All QoS parameters described in [4] shall be supported with the following changes:

- For traffic class, only the background and streaming classes shall be supported.
- Background and streaming classes may have to be extended with a "priority" attribute (the Traffic Handling Priority may be reused for this purpose). The network could use this attribute to selectively drop packets from particular MBMS bearers (typically those providing the highest QoS) when the resources allocated to MBMS are nearing saturation.



### 6.14.1 MBMS QoS is a MBMS service attribute

MBMS data will be distributed to multiple users, so that the QoS cannot be associated to one UE in particular.

### 6.14.2 MBMS QoS over the MBMS distribution tree

MBMS data will be distributed to multiple users through a MBMS distribution tree that can go through many RNCs and many SGSNs. Furthermore some transport resources may be shared between many users accessing the same service in order to save resources.

As a consequence, each branch of a MBMS distribution tree shall be established with the same QoS. The MBMS distribution tree shall have the same QoS for all its branches. It is FFS whether an MBMS service can be provided over multiple distribution trees with differing QoS profiles.

When a branch of the MBMS distribution tree has been created, it is not desirable that the construction of another branch due to arrival of a new UE (or change of location of a UE with removal of a branch and addition of a new one) impacts the already established branches. Else, this implies a heavy mechanism to adjust the QoS of all the already established MBMS branches. As a consequence, QoS negotiation shall not be done by the network nodes. One of the consequence is that some branches may not be established if QoS requirement cannot be accepted by the concerned network node.

QoS negotiation should not be allowed by UMTS network elements.

QoS re-negotiation feature in the RNC should not be allowed for MBMS service.

### 6.14.3 Multiple QoS Streams and Interfacing With the PDN

The GGSN is used to capture MBMS data in the PDN and put this data on one or more GTP tunnels opened as part of the service.

Different media components comprising a single MBMS service from a user's point of view may be provided over separate GTP tunnels and bearers enabling QoS differentiation for each component. The different media components are either transmitted by using one IP multicast group but multiple ports (see option 1) or by using separate IP multicast groups (see option 2). Both alternatives are supported by the session description protocol (SDP). As an example, this could be used when different media with different error protection requirements are transmitted (e.g. audio vs. visual streams or a base video stream with one or more enhancement layers). In some cases, a given MBMS service will be provided in multiple locations with inherently different QoS capabilities. As an example a service might be provided over the GERAN and the UTRAN access networks of the operator requiring the operator to provide a single service in more than one QoS profile, depending on the access network.

Different options for handling multiple QoS profiles per service are presented below.

#### 6.14.3.1 Option 1

To allow multiple media components per transmission, different components can be sent on different destination UDP ports but using the same destination IP multicast address. The GGSN, using TFTs, should be able to tunnel the data through the proper GTP tunnel using the UDP port value to for selecting between different tunnels.

To allow for multiple QoS alternatives targeted at different locations the GGSN should be able to map several alternative transmissions of different media components to different GTP tunnels. Transport of different QoS alternatives on the PDN is FFS.

#### 6.14.3.2 Option 2

Different media components are transmitted on separate IP multicast groups, each identified by a different IP multicast address and requiring a specific Quality of Service handling. A number of GTP tunnels (MBMS bearer services) is set up, one for each destination IP multicast address, and the GGSN maintains a mapping from the IP multicast address to the corresponding GTP tunnel.

To allow for multiple QoS alternatives, possibly targeted at different locations, different IP multicast addresses are also used. The GGSN is required to map several multicast/broadcast transmissions carried over several IP multicast addresses to the same number of distinct groups of GTP tunnels.

Figure 1 provides an example of an MBMS transmission for a multicast service provided with two differing QoS profiles (e.g. for different locations or for different media components).

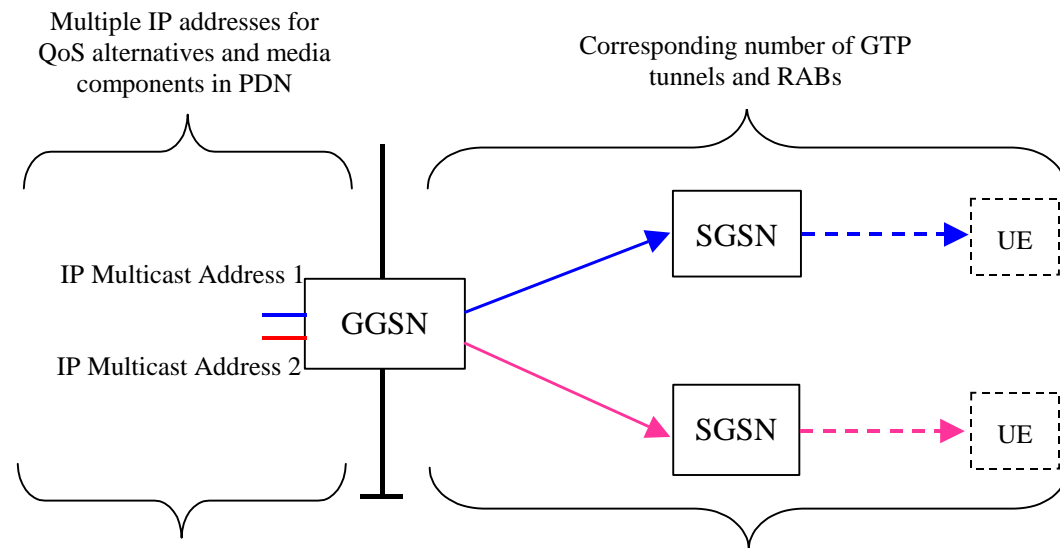

**Figure 33: Example of data flow for multiple QoS profiles of an MBMS transmission**

#### 6.14.4 Handling MBMS User Plane with Multiple QoS Levels within RAN

It is FFS whether the SRNC or the CRNC sends the MBMS data received on MBMS Iu bearer to the UEs via the MBMS radio bearer. This is subject to TSG RAN decision (which could e.g. take into account features such as admission control, congestion information for the cells, number of multicast users per cell, switch between point-to-point and point-to-multipoint configuration, ....)

To handle different congestion levels in different cells, the RNS/BSS may receive multiple streams of the same content with different QoS levels from the "core network" (e.g. one stream for each of the 9 codecs of the WB-AMR set, or, several streams of a video film at different bit rates such as 384, 128, 64 and 32 kbps). Whether, in Iu mode, data are sent via one RAB or multiple RABs for the same content with different QoS levels from core network is FFS.

The UTRAN/BSS is in charge of sending data with appropriate QoS level to the UEs. The way UTRAN/BSS handles QoS is FFS and subject to TSG RAN decision.

In GSM, the BSS selects the appropriate QoS level for each cell according to that cell's congestion level and capabilities (e.g. whether the cell has EDGE capable transceivers or not).

#### 6.14.5 QoS Principles for Related Media Streams

Four types of related media streams are considered:

- Media components

This is the case where the MBMS service requires several distinct types of data (e.g. audio & video) which require separate QoS within the UMTS network.

- Optional media streams

The MBMS service uses several streams of data. The service can still be offered (with lower quality) if some streams are not received. This is typically the case of hierarchical encoding schemes.

- Alternative media streams (QoS)

The MBMS service requires exactly one of a particular set of data streams. The streams contain the same media, but with different QoS, e.g. bit-rate.

- Alternative media streams (Geography)

The MBMS service requires exactly one of a particular set of data streams. The streams contain different media and the stream required depends on the geographic location of the user.

The network (up to the GGSN) may or may not be aware of the relationship between these different media streams. For this reason, several MBMS Bearer Services may be required to offer a single MBMS Service to the user.

In the case of **different media components**, and **alternative data streams based on location**, these shall be treated as separate MBSM Bearer services, i.e. the MBMS Bearer service has a single QoS and single data stream. The network is not aware of any relationships between the MBMS Bearer Services.

In the case of **optional media components**, these are also treated as separate MBMS Bearer services, but a priority indication should be studied. This would allow the RNC to remove/downgrade components which were not essential. Again, the network is not aware of any relationships between the MBMS Bearer Services.

In the case of **alternative media components of differing QoS**, whether the complexity of handling these as separate independent MBMS Bearer services, or of linking several MBMS Bearer Services together, is justified based on the possible savings is ffs.

### 6.14.6 QoS principles for Messaging Services

In contrast to the stream-oriented services described above, it is not the subjective quality perceived by the user that changes, but the transmission duration of the message. A messaging service is characterised by its fixed, pre-determined size.

A possible way to handle this kind of MBMS service could be to set the traffic class attribute for the corresponding GTP tunnel to Background and provision a small buffer in the RNS/BSS to shape the message transmission to the available bandwidth for MBMS traffic in the cell. Other quality of service bearer attributes, together with the resource situation, would only impact the transmission duration of the message, but not the amount of transmitted bytes. The RNS/BSS would not drop any packets. . The buffer size could be either dynamically adapted or pre-configured or possibly requested by the BM-SC and would be applied only when the traffic class is set to Background.

When the UE moves from one cell to another, the unsynchronised transmission between cells may result in part of the message being lost. To cope with such situations, the BM-SC may retransmit the message cyclically, e.g. three times, however this is for further study.

## 6.15 Media Descriptions

Different services may be offered with different combinations and alternatives of media. A service might consist of one or more media components (e.g. a video oriented service with a visual and audio component). Further, any service might be offered at any one time with different QoS depending on available resources in any given cell.

To describe these services to potential applications on the UE (e.g. media players) a media description protocol should be used. The network and specifically the BM-SC should provide the UE application with the media description. A media description should include at the very least:

- Relevant IP multicast address and APN for the service.
- Different possible media components for the service.

For each media component the description should include:

- UDP/IP ports over which the media component is sent and received.
- Media type (e.g. audio or video or data).
- Media formats (e.g. MPEG-4 or H.263).

For the purpose of relaying media description parameters SDP [5] may be preferable as it is already being used in providing such services as IMS. If different alternatives to the same media components need to be described grouping of different alternatives of the same media components should be made possible (reference: "Grouping of Media Lines in SDP", Camarillo et al, February 2002, draft-ietf-mmusic-fid-06.txt).

Media descriptions could potentially be provided to the UE applications in one of several ways. The method chosen may depend on the mechanism used to advertise or announce the service:

- If the service is being advertised using a broadcast mechanism (e.g. a specially designated broadcast or multicast service) the media description might be provided together with the service advertisement. In this scenario SDP may be carried over SAP [6], which provides the functionality necessary for service announcements over broadcast/multicast transport.

The means of providing the media description and the relationship to the service advertisement is FFS.

- If the service is being advertised through a point-to-point mechanism (e.g. web URL) then this same mechanism might be used to provide the UE not only with the advertisement (which is presented to the user) but also with the media description. It should be noted that potentially SDP is suited for carrying advertisements and service descriptions to be presented to the user and hence SDP might be designated as a suitable carrier for both media description and service advertisement.

---

## 7 Network and Protocol Architecture

Options for different network architectures together with a rough description of necessary functionality, procedures, information flows and alterations required for network elements and protocols.

### 7.1 Option A)

This architecture option differentiates between the procedure for MBMS multicast service activation and the procedure for MBMS RAB set-up. The MBMS multicast activation procedure adds an individual UE to all contexts, which describe an MBMS multicast service within the network (the UE joins the multicast group). And this procedure establishes shared MBMS data links within the Core Network between GSNs and BM-SC on demand. The MBMS multicast activation procedure is performed for an individual UE. It has no impact whether data transfer to the multicast group is ongoing or not.

MBMS RABs are not established by the MBMS multicast activation procedure. The MBMS RABs are established for the multicast group and not for individual UEs by the MBMS RAB set-up procedure when MBMS multicast data is available for transfer.

This architecture option establishes data transfer resources only for RNCs and SGSNs that have users of the related MBMS multicast service. This corresponds to options 2) and 4) discussed in clause “MBMS Data Transfer in the Core Network”.

The approach that solves Iu-Flex issues corresponds to options 2) and 4) discussed in clause “Intra Domain Connection of RAN Nodes to Multiple CN Nodes (Iu-Flex)”.

#### 7.1.1 MBMS Multicast Service Activation

The activation procedure registers the user in the network to enable the reception of data from a specific MBMS multicast service. The activation is a signalling procedure between the UE and the network. It establishes the MBMS data transfer path within the network between SGSN(s) and BM-SC. The MBMS multicast service activation does not establish any RABs for the data transfer. The procedure is similar to the PDP context activation.

The activation of an MBMS multicast service without user interaction uses the same procedure. The mechanism which initiates this procedure in this case is FFS (e.g. a request from the network or triggered by data on the SIM after GPRS attach).

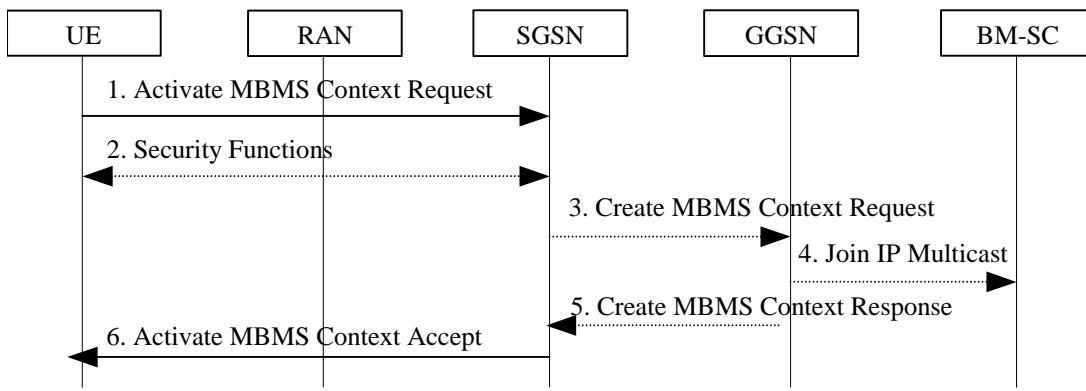

**Figure 34. The activation of an MBMS multicast service**

1. The UE sends an Activate MBMS Context Request to the SGSN. The IP multicast address identifies the MBMS multicast service, which the UE wants to join. An APN indicates a specific GGSN or BM-SC.
2. Security Functions may be performed, e.g. to authenticate the UE.
3. The SGSN checks whether the requested MBMS multicast service identified by the IP multicast address and APN requires a specific subscription or whether a general subscription (e.g. GPRS subscription) allows the activation of the requested service. If it is the first UE activating this specific MBMS multicast service on this SGSN the SGSN requests the creation of an MBMS context on the GGSN and the establishment of a GTP tunnel between the SGSN and the GGSN.
4. If it is the first GTP tunnel for this specific MBMS multicast service on the GGSN the GGSN joins the IP multicast for the requested multicast IP address on the backbone to connect with the MBMS data source (BM-SC).
5. The GGSN confirms the establishment of the MBMS context if performed according to step 4).
6. The SGSN creates a user specific MBMS PDP context, which stores the user parameters of the activated MBMS multicast service. And the SGSN adds the user to an SGSN MBMS context that stores all parameters of the MBMS multicast service. The SGSN sends an Activate MBMS Context Accept to the UE with the parameters TMGI, “recent MBMS key” and “next MBMS key”. The TMGI is used to page all UEs that have activated the MBMS multicast service. The “recent MBMS key” allows for decryption of any MBMS data transfer until the next key change. The “next MBMS key” is used after the next key change..

### 7.1.2 MBMS Broadcast Service activation

The MBMS broadcast service activation is local on the UE and local in the network. The user enables on the UE the reception of data from a specific MBMS broadcast service. This activation on the UE does not establish any data transfer resources.

The activation procedure in the network is comparable to the multicast activation. An SGSN MBMS context is configured that stores all parameters of the MBMS service. These parameters may be the multicast IP address of the service, the APN, the service area and the QoS for the data transfer. The connections within the network are set-up when the SGSN re-starts or when an MBMS broadcast service (SGSN MBMS context) is set-up by O&M. The activation procedure establishes the MBMS data transfer path within the network between SGSN(s) and BM-SC. The MBMS broadcast service activation in the network does not establish any RABs for the data transfer.

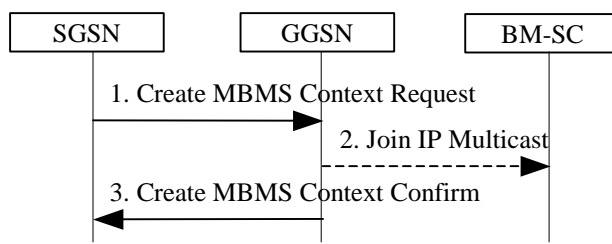
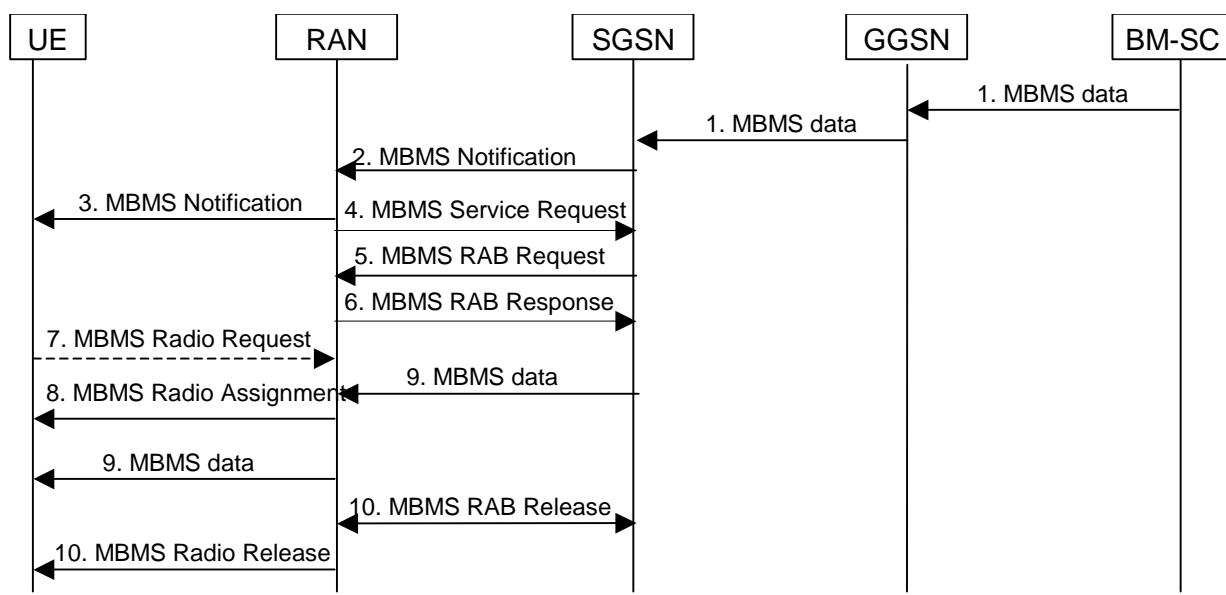

**Figure 35. The activation of an MBMS broadcast service**

1. At a SGSN re-start or when a new MBMS broadcast service is set-up the SGSN requests the creation of an MBMS context on the GGSN and the establishment of a GTP tunnel between the SGSN and the GGSN.
2. If it is the first GTP tunnel for this specific MBMS multicast service the GGSN joins the IP multicast for the requested multicast IP address on the backbone to connect with the MBMS data source (BM-SC or other).
3. The GGSN confirms the establishment of the MBMS context.

### 7.1.3 MBMS RAB set-up

The MBMS RAB set-up procedure establishes the RABs for a specific MBMS service when MBMS data have to be transferred. The procedure is used for MBMS broadcast and MBMS multicast data transfer.



**Figure 36. MBMS RAB set-up**

1. The BM-SC (or another MBMS data source) sends MBMS data for a specific MBMS service that are received by the SGSN.
2. The SGSN sends an MBMS Notification to any RAN node that serves the MBMS service area. The MBMS notification indicates the TMGI and the MBMS service area.
3. Each RAN node sends an MBMS Notification to the UEs within the MBMS service area.
4. Each RAN sends one or multiple MBMS Service Request messages to the SGSN. A RAN node may need multiple MBMS Iu bearers to cover the MBMS service area, e.g. for RAN node internal load sharing. The MBMS Service Request messages are sent regardless whether there are any UEs in the area of the RAN node or not.
5. The SGSN sends per received MBMS Service Request an MBMS RAB Request message to the RAN node(s). The message indicates the QoS parameters required for the RAB.
6. The RAN node sends per MBMS RAB Request an MBMS RAB Response to the SGSN that establishes the MBMS Iu bearers between the RAN node and the SGSN.

7. The UEs which have activated this MBMS service and which receive the MBMS Notification send an MBMS Radio Request message to the RAN. A back-off mechanism to prevent too many request messages is FFS.
8. The RAN establishes MBMS radio bearers and indicates the related radio bearer parameters by MBMS Radio Assignment messages in the cells where MBMS Radio Request messages were received.
9. When the MBMS Iu bearer between the RAN node(s) and the SGSN is established the SGSN starts to duplicate and to send received MBMS data on all established MBMS RABs. The RAN node(s) duplicate and send these data on the MBMS radio bearers.
10. When the SGSN receives no more MBMS data it may release the MBMS RAB. This causes the RAN to release the MBMS radio bearers.

### 7.1.3.1 MBMS RAB set-up with Iu-Flex

By means of Iu-Flex multiple SGSN may serve the same radio coverage area. The MBMS RAB set-up procedure results in notifications from multiple SGSN to the same RNC. The RNC detects that multiple SGSNs have MBMS data for the same MBMS multicast service, e.g. from the same TMGI or from another information element. The RNC establishes RABs with all SGSNs and transfers only a part of the received MBMS data on the MBMS radio bearers to avoid duplication at the radio transfer. All SGSNs receive the same MBMS data and collect charging information for the user with activated MBMS multicast services.

All SGSNs may allocate the same TMGI for the same MBMS multicast service to allow the RNC to detect multiple MBMS Notifications for the same MBMS multicast service. Alternatively, another information element in the notification may be used for that purpose, e.g. the IP multicast address of the MBMS service. Different cipher keys from different SGSNs should be avoided as this would require transferring the same data multiple times on the radio interface encrypted by different keys.

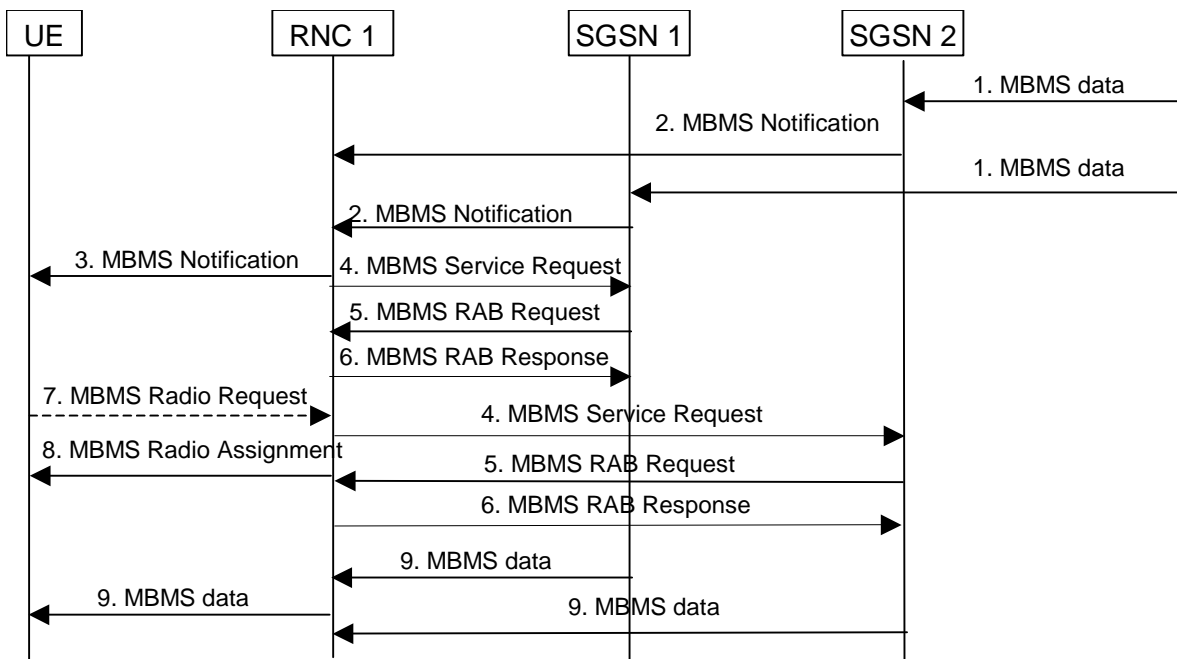

**Figure 37: MBMS RAB set-up with IuFlex**

1. The BM-SC sends MBMS data that are received by all SGSNs that serve the same pool-area.
2. Each of the SGSNs sends an MBMS Notification to the RNCs indicating the TMGI and the MBMS service area.
3. The RNC detects that multiple SGSNs send the same notification. The RNC sends an MBMS Notification to the UEs within the MBMS service area.
4. The RNC sends an MBMS Service Request messages to each of the SGSNs.
5. Each SGSN sends an MBMS RAB Request message to the RNC. The message indicates the QoS parameters required for the RAB.
6. The RNC sends an MBMS RAB Response to the SGSN, which establishes the MBMS Iu bearer between the RNC and the SGSN.
7. The UEs which have activated this MBMS service and which receive the MBMS Notification send an MBMS Radio Request message to the network. A back-off mechanism may prevent too many MBMS Radio Request messages. FFS.
8. The RNC establishes MBMS radio bearers and indicates the related radio bearer parameters by MBMS Radio Assignment messages in the cells where MBMS Radio Request messages were received.
9. When the MBMS Iu bearer(s) between the RNC and the SGSN are established each SGSN starts to duplicate and to send received MBMS data on all established RABs. The RAN duplicates and sends these data on the MBMS radio bearer(s).

## 7.1.4 Service Continuity and Mobility

### 7.1.4.1 MBMS SGSN change procedure

This procedure is performed when a UE in GMM IDLE changes the SGSN, i.e. there are no RABs and no signalling connections with the SGSN. The RABs for MBMS services are not exclusive for individual UEs. A signalling connection for an UE with MBMS services only is not intended as this is against the multicast concept. UEs which have only active MBMS services, are therefore in GMM IDLE. These UEs perform the Routeing Area update with MBMS extensions as described below. The procedure is performed regardless whether MBMS data transfer is ongoing or not. The handling of potential ptp PDP contexts is not affected. The described procedure shows not all details of the Routeing Area update procedure. The MBMS specific additions to the Routeing Area update procedure are in bold.



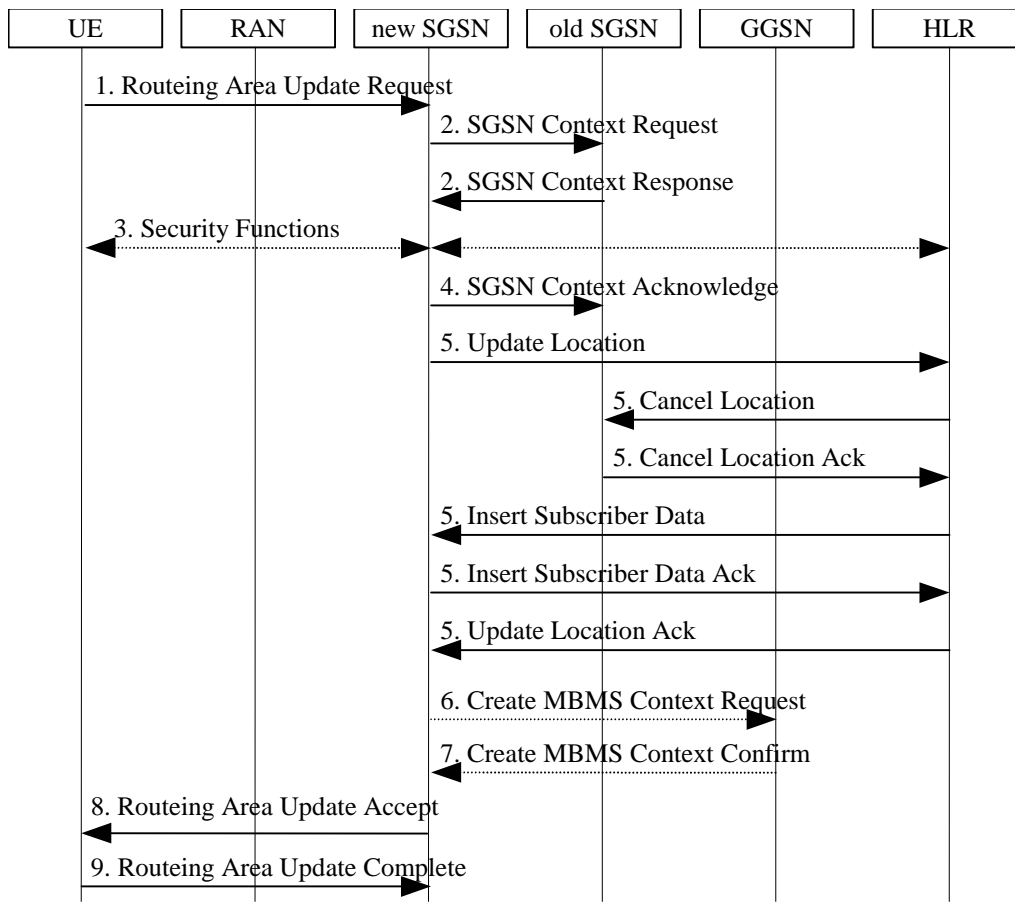

**Figure 38. Mobility between SGSNs**

1. The UE moves from the service area of the old SGSN to the service area of the new SGSN. The UE sends a Routing Area Update Request to the new SGSN. The RAN shall add an identity of the area where the message was received before passing the message to the SGSN.
2. The new SGSN sends SGSN Context Request to the old SGSN to get the MM, the PDP and the MBMS PDP contexts for the UE. The old SGSN sends all UE contexts with the SGSN Context Response to the new SGSN.
3. Security functions may be executed, e.g. authenticating the UE.
4. The new SGSN sends an SGSN Context Acknowledge message to the old SGSN to indicate that it has taken over the control for that UE.
5. All procedures to provide the subscription and security data in the new SGSN and to register the new SGSN at the HLR are performed. The old SGSN removes the user from the SGSN MBMS context(s) for any MBMS multicast service.
6. The new SGSN validates the UE's presence. If due to roaming restrictions the UE is not allowed to be attached in the SGSN, or if subscription checking fails, the new SGSN rejects the routing area update with an appropriate cause. If all checks are successful, the new SGSN constructs MM, PDP and MBMS contexts for the UE. The new SGSN adds the user to the SGSN MBMS context(s) for each MBMS multicast service the user has activated. If it is the first UE with this specific MBMS multicast service on this SGSN the SGSN requests the creation of an MBMS context on the GGSN and the establishment of a GTP tunnel between the SGSN and the GGSN.
7. The GGSN confirms the establishment of the MBMS context if performed according to step 6.
8. The new SGSN responds to the UE with Routing Area Update Accept. One or more TMGI may be allocated to the UE for MBMS. In addition the parameters "recent MBMS key" and "next MBMS key" may be sent to the UE.

9. The UE acknowledges the new parameters by returning a Routeing Area Update Complete.

### 7.1.4.2 MBMS relocation and handover

This procedure is performed when a UE in GMM CONNECTED changes the SGSN, i.e. there is a signalling connections with the SGSN. The RABs of ptp services are transferred by relocation/handover. MBMS RABs are not exclusive for individual UEs. Active MBMS services of the UE are transferred to the new SGSN by the context transfer which is embedded in the relocation/handover procedures. The procedure is performed regardless whether MBMS data transfer is ongoing or not. The described procedure shows not all details of the relocation procedure. Only the relocation procedure is described. The handover procedure has similar extensions for MBMS. The MBMS specific additions to the relocation procedure are in bold.

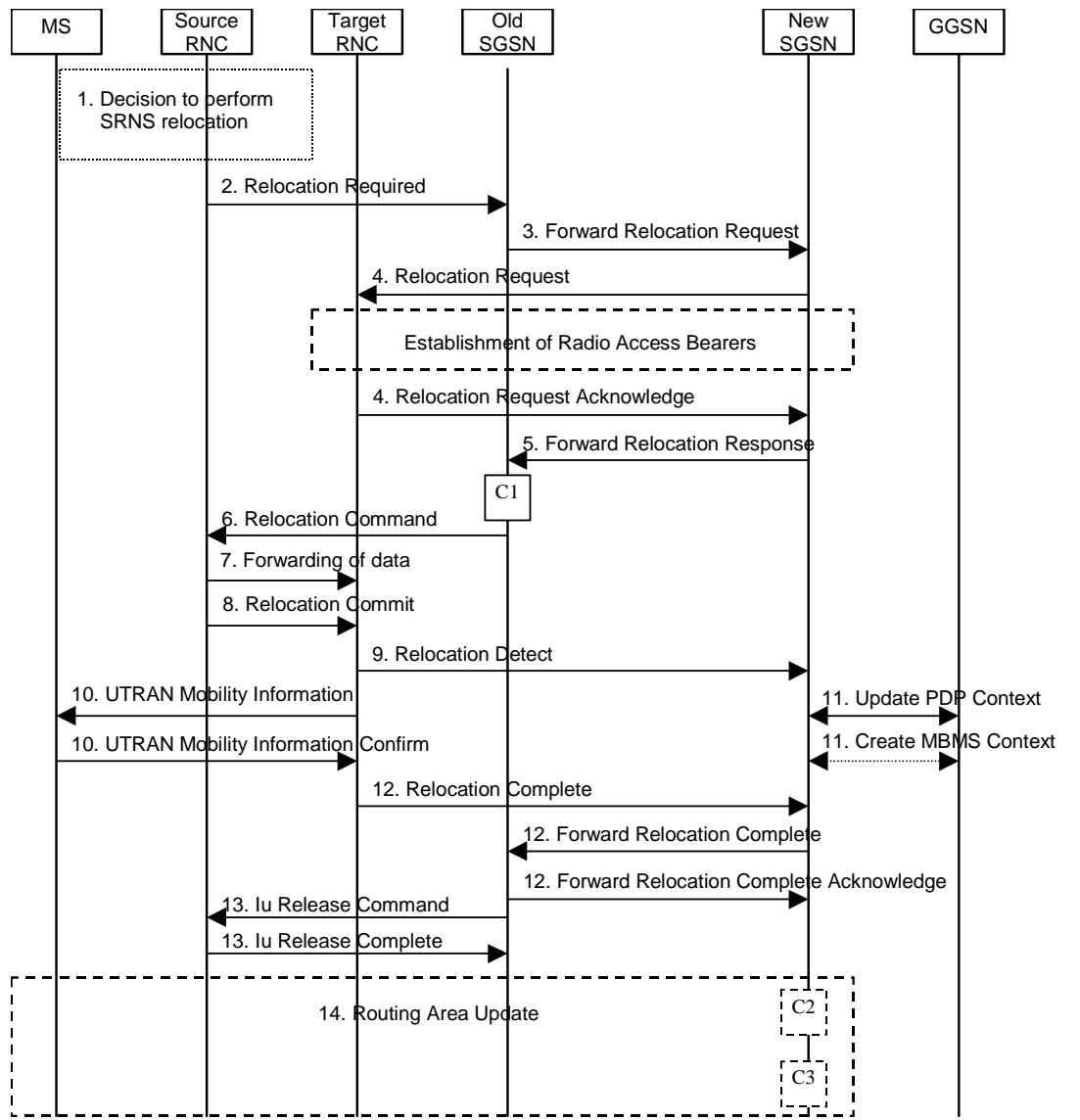

**Figure 39.: SRNS Relocation Procedure**

- 1) [The source SRNC decides to perform/initiate SRNS relocation.](#)
- 2) [The source SRNC sends a Relocation Required message \(Relocation Type, Cause, Source ID, Target ID, Source RNC to target RNC transparent container\) to the old SGSN. The source SRNC shall set the Relocation Type to "UE not involved". The Source SRNC to Target RNC Transparent Container includes the necessary information for Relocation co-ordination, security functionality and RRC protocol context information \(including MS Capabilities\).](#)

- 3) The old SGSN determines from the Target ID if the SRNS Relocation is an intra-SGSN SRNS relocation or an inter-SGSN SRNS relocation. In case of inter-SGSN SRNS relocation, the old SGSN initiates the relocation resource allocation procedure by sending a Forward Relocation Request message (IMSI, Tunnel Endpoint Identifier Signalling, MM Context, PDP Context, **MBMS PDP context**, Target Identification, UTRAN transparent container, RANAP Cause) to the new SGSN. The Forward Relocation Request message is applicable only in the case of inter-SGSN SRNS relocation.
- 4) The new SGSN sends a Relocation Request message (Permanent NAS UE Identity, Cause, CN Domain Indicator, Source-RNC to target RNC transparent container, RABs to be setup) to the target RNC. Only the Iu Bearers of the RABs are setup between the target RNC and the new-SGSN as the existing Radio Bearers will be reallocated between the MS and the target RNC when the target RNC takes the role of the serving RNC.
- 5) When resources for the transmission of user data between the target RNC and the new SGSN have been allocated and the new SGSN is ready for relocation of SRNS, the Forward Relocation Response message (Cause, RANAP Cause, and RAB Setup Information) is sent from the new SGSN to old SGSN. This message indicates that the target RNC is ready to receive from source SRNC the forwarded downlink PDUs, i.e. the relocation resource allocation procedure is terminated successfully. The Forward Relocation Response message is applicable only in case of inter-SGSN SRNS relocation.
- 6) The old SGSN continues the relocation of SRNS by sending a Relocation Command message (RABs to be released, and RABs subject to data forwarding) to the source SRNC. The old SGSN decides the RABs to be subject for data forwarding based on QoS, and those RABs shall be contained in RABs subject to data forwarding.
- 7) The source SRNC may, according to the QoS profile, begin the forwarding of data for the RABs to be subject for data forwarding.
- 8) Before sending the Relocation Commit the uplink and downlink data transfer in the source, SRNC shall be suspended for RABs, which require delivery order. The source RNC shall start the data-forwarding timer. When the source SRNC is ready, the source SRNC shall trigger the execution of relocation of SRNS by sending a Relocation Commit message (SRNS Contexts) to the target RNC over the Iur interface.
- 9) The target RNC shall send a Relocation Detect message to the new SGSN when the relocation execution trigger is received. For SRNS relocation type "UE not involved", the relocation execution trigger is the reception of the Relocation Commit message from the Iur interface. When the Relocation Detect message is sent, the target RNC shall start SRNC operation.
- 10) The target SRNC sends a UTRAN Mobility Information message. This message contains UE information elements and CN information elements. The UE information elements include among others new SRNC identity and S-RNTI. The CN information elements contain among others Location Area Identification and Routing Area Identification. The procedure shall be co-ordinated in all Iu signalling connections existing for the MS.
- 11) Upon receipt of the Relocation Detect message, the CN may switch the user plane from source RNC to target SRNC. If the SRNS Relocation is an inter SGSN SRNS relocation, the new SGSN sends Update PDP Context Request messages to the GGSNs concerned. The GGSNs update their PDP context fields and return an Update PDP Context Response. **If the SRNS Relocation is an inter SGSN SRNS relocation, the new SGSN adds the user to the SGSN MBMS context(s) for each MBMS multicast service the user has activated. If it is the first UE with this specific MBMS multicast service on this SGSN the SGSN requests the creation of an MBMS context on the GGSN and the establishment of a GTP tunnel between the SGSN and the GGSN.**
- 12) When the target SRNC receives the UTRAN Mobility Information Confirm message, i.e. the new SRNC—ID + S-RNTI are successfully exchanged with the MS by the radio protocols, the target SRNC shall initiate the Relocation Complete procedure by sending the Relocation Complete message to the new SGSN. The purpose of the Relocation Complete procedure is to indicate by the target SRNC the completion of the relocation of the SRNS to the CN.
- 13) Upon receiving the Relocation Complete message or if it is an inter-SGSN SRNS relocation; the Forward Relocation Complete message, the old SGSN sends an Iu Release Command message to the source RNC. When the RNC data-forwarding timer has expired the source RNC responds with an Iu Release Complete.
- 14) After the MS has finished the RNTI reallocation procedure and if the new Routing Area Identification is different from the old one, the MS initiates the Routing Area Update procedure. See subclause "Location Management Procedures (Iu mode only)". **The old SGSN removes the user from the SGSN MBMS context(s) for any MBMS multicast service.** Note that it is only a subset of the RA update procedure that is

performed, since the MS is in PMM-CONNECTED mode. New TMGI(s) may be allocated to the UE for MBMS services. In addition the parameters “recent MBMS key” and “next MBMS key” may be sent to the UE.

## 7.1.5 Service Deletion

### 7.1.5.1 UE Initiated MBMS Multicast Deactivation Procedure

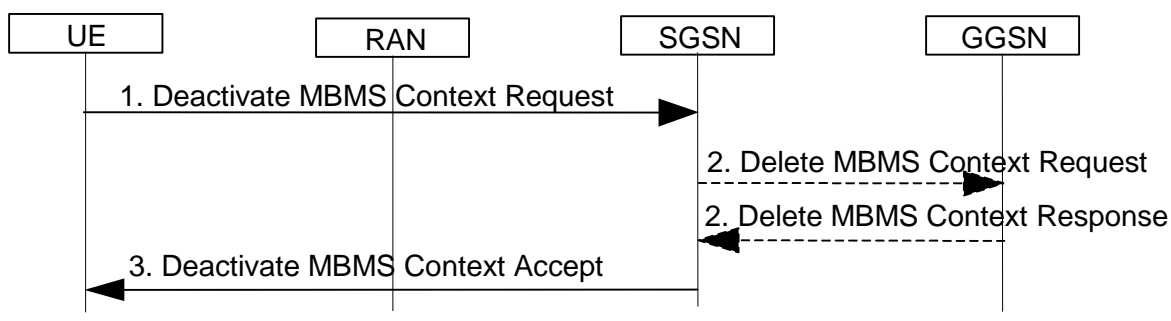
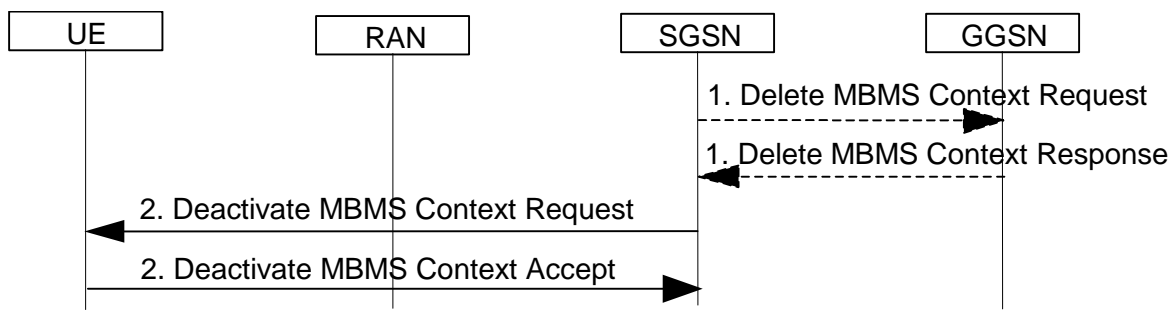

**Figure 40: UE Initiated PDP Context Deactivation Procedure for Iu mode**

- 1) The UE sends a Deactivate MBMS Context Request message to the SGSN.
- 2) The SGSN deletes the MBMS PDP context and removes the user from the SGSN MBMS context. If there are no more users of that MBMS multicast service on the SGSN the SGSN sends a Delete PDP Context Request message to the GGSN. The GGSN releases the related GTP tunnel and returns a Delete MBMS Context Response message to the SGSN.
- 3) The SGSN returns a Deactivate MBMS Context Accept message to the UE.

At GPRS detach, all PDP and MBMS PDP contexts for the UE are implicitly deactivated.

### 7.1.5.2 Network-initiated MBMS Multicast Deactivation Procedure



**Figure 41: SGSN-initiated MBMS Context Deactivation Procedure**

- 1) The SGSN deletes the PDP MBMS context and removes the user from the SGSN MBMS context. If there are no more users of that MBMS multicast service on the SGSN the SGSN sends a Delete MBMS Context Request message to the GGSN. The GGSN releases the related GTP tunnel and returns a Delete MBMS Context Response message to the SGSN.
- 2) The SGSN sends a Deactivate MBMS Context Request message to the UE. The UE removes the PDP MBMS context(s) and returns a Deactivate MBMS Context Accept message to the SGSN.

## 7.1.6 Interfaces to External Media Sources

Media sources that transfer data on IP multicast may connect to the GGSN for delivery of MBMS data via MBMS multicast or broadcast to UEs. The data format has to be conform to the application on the UE. If these media sources are not located within the PLMN a firewall typically restricts IP addresses and QoS.

Other media sources may connect with the BM-SC to provide content. This interface is not standardised. For example, a web-interface may allow internal and external media sources to submit MBMS data. The data format is not restricted; the BM-SC converts the data format according to the needs of application on the UE. The BM-SC provides access control, authentication and charging of the service requester (content provider).

## 7.1.7 Roaming

MBMS broadcast services are defined and provided only within the coverage area of one PLMN. Any UE may receive MBMS broadcast services of the visited PLMN regardless whether it is the UE's home-PLMN or whether the UE roams in the PLMN.

The procedures described above support also MBMS service provision in case of roaming. MBMS multicast services may be delivered by the home-PLMN to UEs roaming in other PLMNs. In this case the UE uses the MBMS APN of its home-PLMN. The SGSN of the visited PLMN establishes a GTP tunnel with a GGSN in the home-PLMN. The visited PLMN allows such services for roamers based on O&M and based on HLR subscription.

The visited PLMN may provide its MBMS multicast services to UEs of other PLMNs, which roam in the visited PLMN. For this purpose the UEs use the MBMS APN of the visited PLMN. The visited PLMN has to accept a general MBMS subscription, as it is unlikely that the home PLMN registers subscriptions for MBMS services of other PLMNs in its HLR.

## 7.1.8 Security

The MBMS multicast data transmission to the UEs has to be secured for two reasons. The multicast group may want privacy for its data. And, encryption shall prevent unauthorised (uncharged) reception of MBMS data. Both is reached by encryption of MBMS data. The mechanism to allocate the cipher keys to the receivers requires input from SA3. Frequent cipher key reallocations may be required especially for large receiver groups.

To prevent unauthorised reception the receivers have to be authenticated and their service usage has to be authorised. The UMTS authentication procedure authenticates the receivers. UMTS subscription, especially GPRS subscription, allows to authorise the usage of MBMS multicast services. Authentication and authorisation are also required to generate charging records for individual receivers.

Typically a content provider is liable for the provided content and for the charge of the service provision. For these reasons the MB-SC authenticates and authorises the content providers of MBMS multicast and broadcast services. Furthermore, the integrity of the content data has to be guaranteed. Authentication and authorisation are also required to generate charging records for the content providers. The security mechanisms towards content providers will probably not be standardised.

## 7.1.9 Charging

The functions to authenticate and authorise MBMS multicast receivers are allocated on the SGSN. This allows the SGSN to generate charging records for the each MBMS multicast receiver. The records are comparable to the charging records generated for the usage of point to point bearer services.

The BM-SC authenticates and authorises MBMS multicast and broadcast content providers. Therefore, the BM-SC generates charging records for each content provider. The content is similar to that of the receiver charging records. It may contain the sent data volume, service usage times, related QoS. In addition the content provider charging records may contain the service area.

## 7.2 Option B)

### 7.2.1 MBMS Multicast Service Activation

The activation procedure registers the user in the network to enable the reception of data from a specific MBMS multicast service. The activation is a signalling procedure between the UE and the network. It establishes the MBMS data transfer path within the network between SGSN(s) and BM-SC. The MBMS multicast service activation does not establish any RABs for the data transfer. The procedure is similar to the PDP context activation.

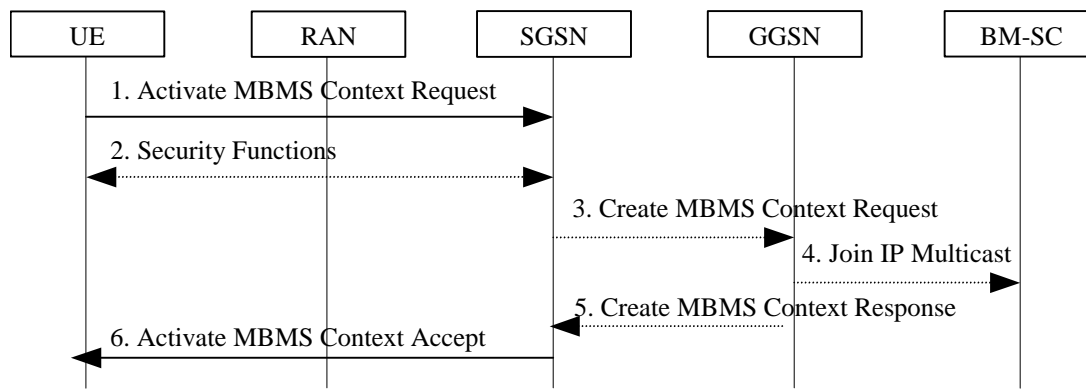

**Figure 42: The activation of an MBMS multicast service**

1. The UE sends an Activate MBMS Context Request to the SGSN. The IP multicast address identifies the MBMS multicast service, which the UE wants to join. An APN indicates a specific GGSN. The SGSN validates the Activate MBMS Context Request, determines the RNCs serving the routing area where the UE is located and creates as many MBMS contexts as there are RNCs serving the routing area. The MBMS context(s) store the parameters of the activated MBMS multicast service.
2. Security Functions may be performed, e.g. to authenticate the UE.
3. If it is the first UE activating this specific MBMS multicast service on this routing area, the SGSN determines the RNCs serving the routing area and requests for each the creation of an MBMS context on the GGSN and the establishment of a GTP tunnel between the SGSN and the GGSN.
4. If it is the first GTP tunnel for this specific MBMS multicast service on the GGSN, the GGSN joins the IP multicast for the requested multicast IP address on the backbone to connect with the MBMS data source (BM-SC).
5. The GGSN confirms the establishment of the MBMS context(s) if performed according to step 4).
6. The SGSN sends an Activate MBMS Context Accept to the UE with the parameter TMGI.

### 7.2.2 MBMS Broadcast Service activation

#### 7.2.2.1 Network initiated MBMS broadcast activation

The MBMS broadcast service activation is local on the UE and local in the network. The user enables on the UE the reception of data from a specific MBMS broadcast service. This activation does not establish any data transfer resources.

The activation procedure in the network is comparable to the multicast activation. The connections within the network are set-up when the SGSN re-starts or when an MBMS broadcast service is set-up by O&M. The activation procedure establishes the MBMS data transfer path within the network between SGSN(s) and BM-SC. The MBMS broadcast service activation does not establish any RABs for the data transfer.

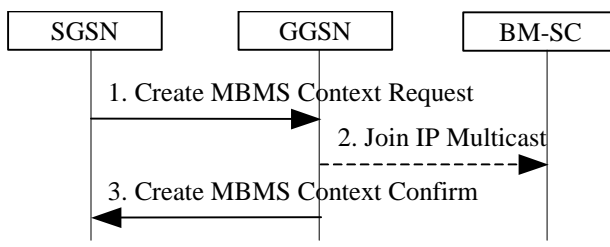

**Figure 43: The activation of an MBMS broadcast service**

1. At a SGSN re-start or when a new MBMS broadcast service is set-up, the SGSN determines the RNCs covering this Broadcast service area and requests for each the creation of an MBMS context on the GGSN and the establishment of GTP tunnels between the SGSN and the GGSN. The number of MBMS contexts created in SGSN for a specific service are equal to the number of RNCs determined by the SGSN covering this service area.
2. If it is the first GTP tunnel for this specific MBMS broadcast service the GGSN joins the IP multicast for the requested multicast IP address on the backbone to connect with the MBMS data source (BM-SC).
3. The GGSN confirms the establishment of the MBMS context.

### 7.2.3 MBMS RAB set-up

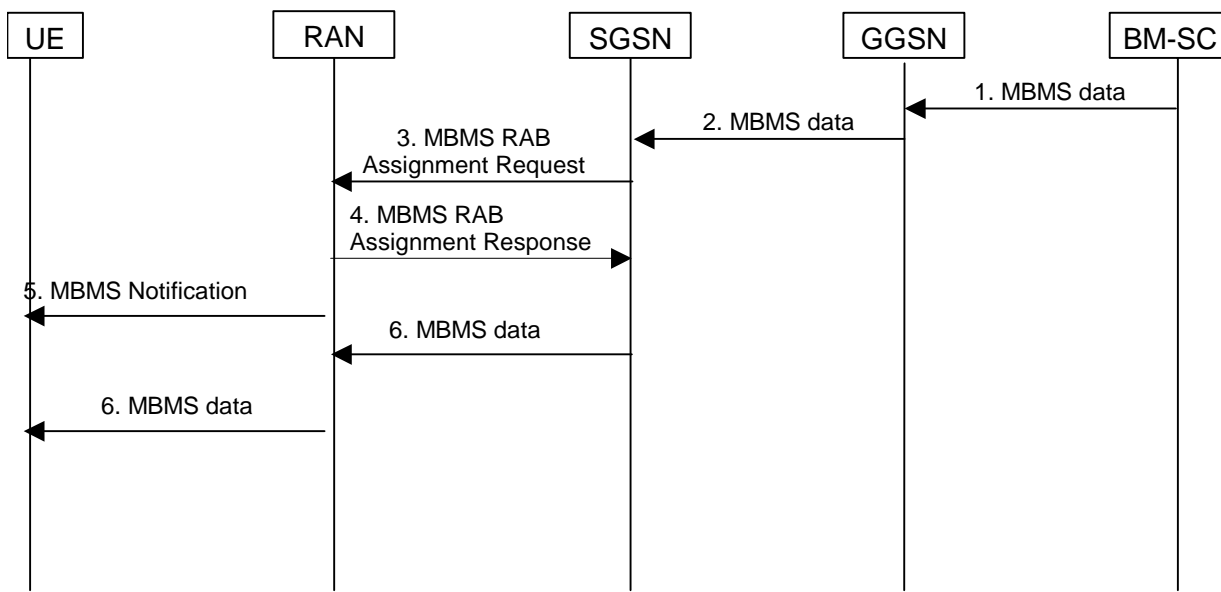

1. BM-SC sends MBMS data to the GGSN.
2. GGSN sends the data to all Gn/Gp tunnels that SGSNs have established for this IP multicast address.
3. The SGSN initiates MBMS RAB establishment for each MBMS context when it receives MBMS data on the MBMS context. The SGSN determines the relevant RNC from the stored MBMS context

In MBMS multicast case the SGSN sends MBMS RAB Assignment Request (indicating e.g. QoS parameters) only to the RNCs serving the Routing Areas in which there are UEs which have joined the MBMS context. This means that SGSN sets up MBMS RABs on Routing Area basis to all RNCs serving the RA even though there would be no MBMS capable users under the RNC's coverage area.

- 4. [RNC replies with MBMS RAB Assignment Response indicating that the MBMS RAB was successfully established.](#)
- 5. [The RNC sets up radio bearers towards the cells involved and sends MBMS Notification to UEs.](#)
- 6. [MBMS Data is sent to UEs.](#)

[It is FFS whether the RNC may downgrade QoS. If QoS is downgraded, the SGSN has to inform the GGSN with the Update MBMS Context procedure.](#)

## 7.2.4 Service Continuity and Mobility

### 7.2.4.1 MBMS SGSN change procedure

[This procedure is performed when a UE in PMM IDLE changes the SGSN, i.e. there are no RABs and no signalling connections with the SGSN. The RABs for MBMS services are not exclusive for individual UEs. A signalling connection for an UE with MBMS services only is not intended as this is against the multicast concept. UEs which have only active MBMS services are therefore in PMM IDLE. These UEs perform the Routeing Area update with MBMS extensions as described below. The procedure is performed regardless whether MBMS data transfer is ongoing or not. The handling of potential ptp PDP contexts is not affected. The described procedure shows not all details of the Routeing Area update procedure.](#)

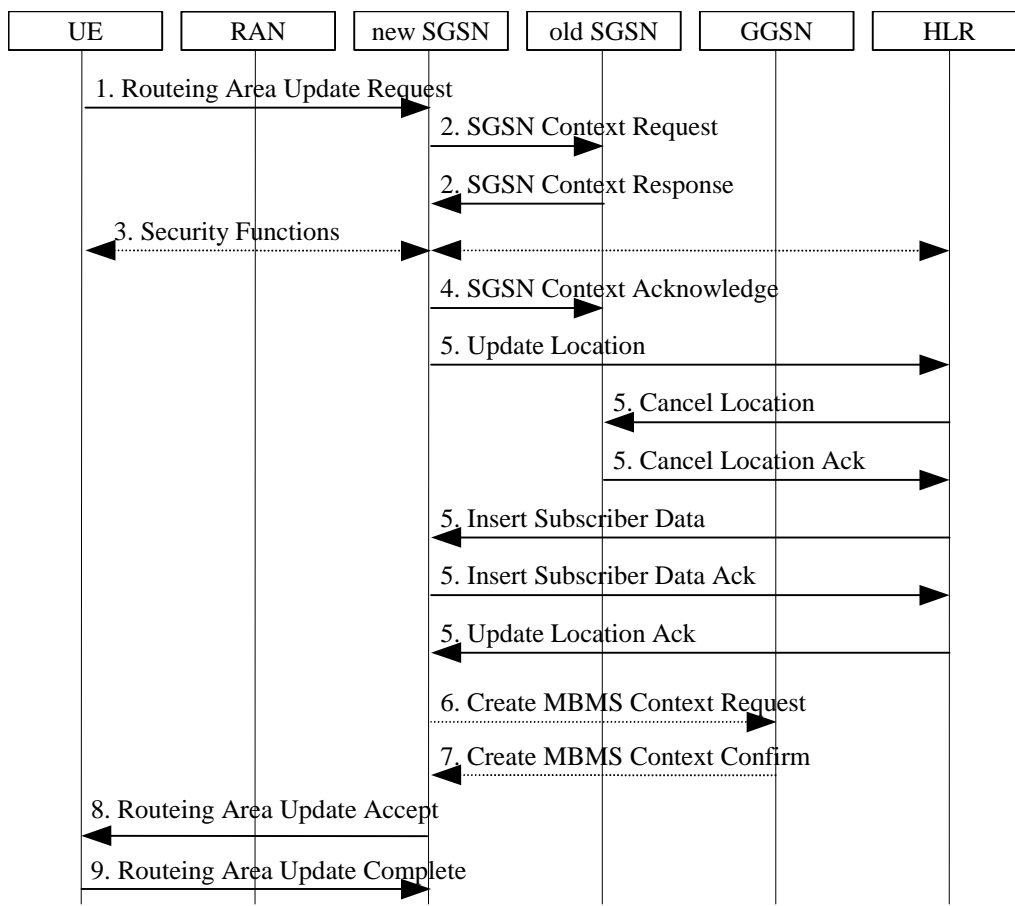

**Figure 44: Mobility between SGSNs**

- 1. [The UE moves from the service area of the old SGSN to the service area of the new SGSN. The UE sends a Routeing Area Update Request to the new SGSN. The RAN shall add an identity of the area where the message was received before passing the message to the SGSN.](#)
- 2. [The new SGSN sends SGSN Context Request to the old SGSN to get the MM, the PDP and the MBMS contexts for the UE. The old SGSN sends all UE contexts with the SGSN Context Response to the new SGSN.](#)
- 3. [Security functions may be executed, e.g. authenticating the UE.](#)



4. The new SGSN sends an SGSN Context Acknowledge message to the old SGSN to indicate that it has taken over the control for that UE.
5. All procedures to provide the subscription and security data in the new SGSN and to register the new SGSN at the HLR are performed.
6. The new SGSN validates the UE's presence. If due to roaming restrictions the UE is not allowed to be attached in the SGSN, or if subscription checking fails, the new SGSN rejects the routeing area update with an appropriate cause. If all checks are successful, the new SGSN constructs MM, PDP and MBMS contexts for the UE. The new SGSN checks each individual MBMS service indicated by the MBMS contexts of the UE. If it is the first UE with this specific MBMS multicast service on this SGSN, the SGSN determines the RNCs serving the routing area where the UE is located and requests for each the creation of an MBMS context on the GGSN and the establishment of GTP tunnels between the SGSN and the GGSN.
7. The GGSN confirms the establishment of the MBMS context if performed according to step 6.
8. The new SGSN responds to the UE with Routeing Area Update Accept. One or more TMGI may be allocated to the UE for MBMS.
9. The UE acknowledges the new parameters by returning a Routeing Area Update Complete.

#### 7.2.4.2 MBMS relocation and handover

This procedure is performed when a UE in PMM CONNECTED changes the SGSN, i.e. there is a signalling connections with the SGSN. The RABs of ptp services are transferred by relocation/handover. MBMS RABs are not exclusive for individual UEs. Active MBMS services of the UE are transferred to the new SGSN by the context transfer which is embedded in the relocation/handover procedures. The procedure is performed regardless whether MBMS data transfer is ongoing or not. The described procedure shows not all details of the relocation procedure. Only the relocation procedure is described. The handover procedure has similar extensions for MBMS.

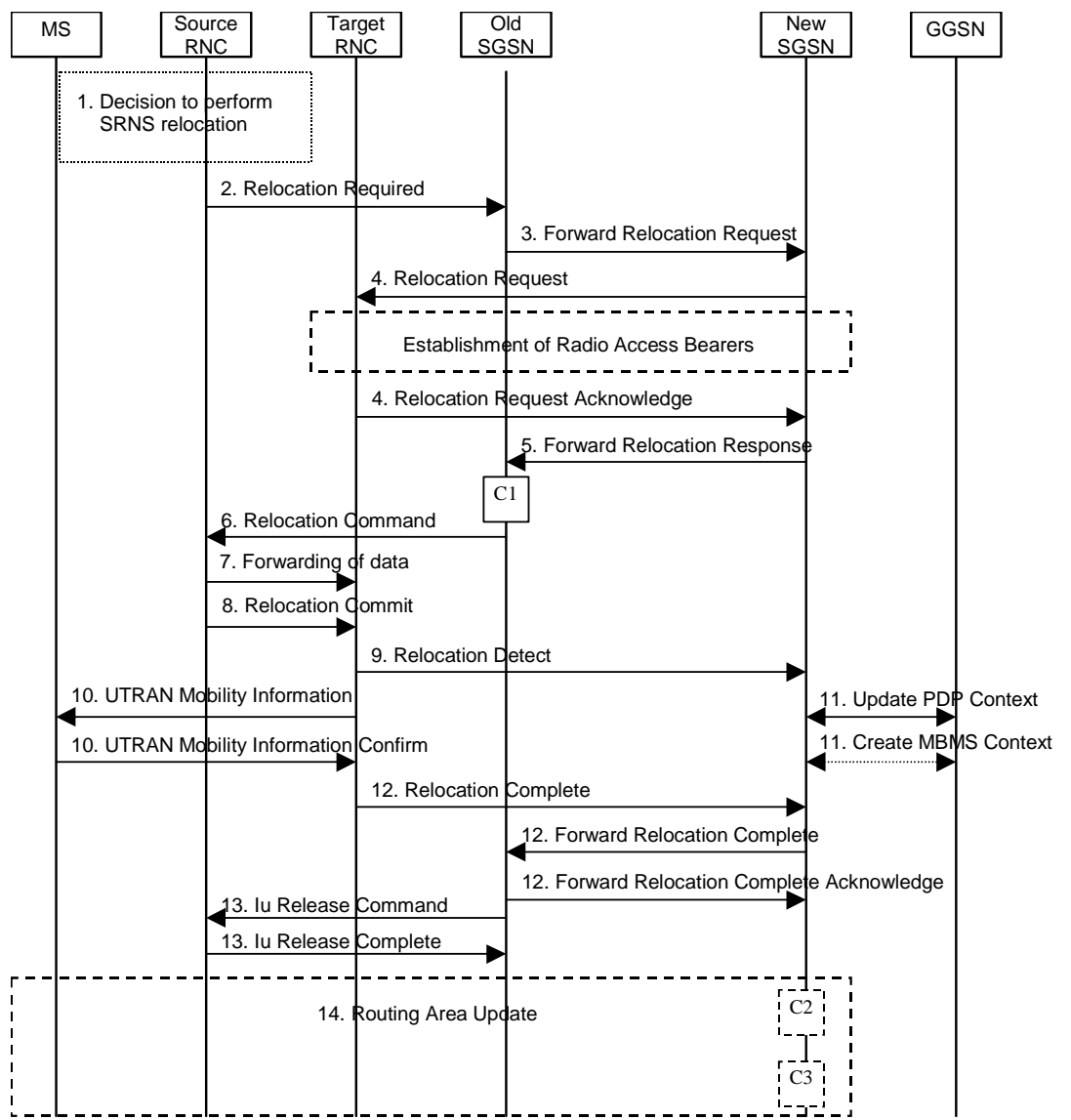

**Figure 45: SRNS Relocation Procedure**

- 1) The source SRNC decides to perform/initiate SRNS relocation.
- 2) The source SRNC sends a Relocation Required message (Relocation Type, Cause, Source ID, Target ID, Source RNC to target RNC transparent container) to the old SGSN. The source SRNC shall set the Relocation Type to "UE not involved". The Source SRNC to Target RNC Transparent Container includes the necessary information for Relocation co-ordination, security functionality and RRC protocol context information (including MS Capabilities).
- 3) The old SGSN determines from the Target ID if the SRNS Relocation is an intra-SGSN SRNS relocation or an inter-SGSN SRNS relocation. In case of inter-SGSN SRNS relocation, the old SGSN initiates the relocation resource allocation procedure by sending a Forward Relocation Request message (IMSI, Tunnel Endpoint Identifier Signalling, MM Context, PDP Context, MBMS context, Target Identification, UTRAN transparent container, RANAP Cause) to the new SGSN. The Forward Relocation Request message is applicable only in the case of inter-SGSN SRNS relocation.
- 4) The new SGSN sends a Relocation Request message (Permanent NAS UE Identity, Cause, CN Domain Indicator, Source-RNC to target RNC transparent container, RABs to be setup) to the target RNC. Only the Iu Bearers of the RABs are setup between the target RNC and the new-SGSN as the existing Radio Bearers will be reallocated between the MS and the target RNC when the target RNC takes the role of the serving RNC.

- 5) When resources for the transmission of user data between the target RNC and the new SGSN have been allocated and the new SGSN is ready for relocation of SRNS, the Forward Relocation Response message (Cause, RANAP Cause, and RAB Setup Information) is sent from the new SGSN to old SGSN. This message indicates that the target RNC is ready to receive from source SRNC the forwarded downlink PDUs, i.e. the relocation resource allocation procedure is terminated successfully. The Forward Relocation Response message is applicable only in case of inter-SGSN SRNS relocation.
- 6) The old SGSN continues the relocation of SRNS by sending a Relocation Command message (RABs to be released, and RABs subject to data forwarding) to the source SRNC. The old SGSN decides the RABs to be subject for data forwarding based on QoS, and those RABs shall be contained in RABs subject to data forwarding.
- 7) The source SRNC may, according to the QoS profile, begin the forwarding of data for the RABs to be subject for data forwarding.
- 8) Before sending the Relocation Commit the uplink and downlink data transfer in the source, SRNC shall be suspended for RABs, which require delivery order. The source RNC shall start the data-forwarding timer. When the source SRNC is ready, the source SRNC shall trigger the execution of relocation of SRNS by sending a Relocation Commit message (SRNS Contexts) to the target RNC over the Iur interface.
- 9) The target RNC shall send a Relocation Detect message to the new SGSN when the relocation execution trigger is received. For SRNS relocation type "UE not involved", the relocation execution trigger is the reception of the Relocation Commit message from the Iur interface. When the Relocation Detect message is sent, the target RNC shall start SRNC operation.
- 10) The target SRNC sends a UTRAN Mobility Information message. This message contains UE information elements and CN information elements. The UE information elements include among others new SRNC identity and S-RNTI. The CN information elements contain among others Location Area Identification and Routeing Area Identification. The procedure shall be co-ordinated in all Iu signalling connections existing for the MS.
- 11) Upon receipt of the Relocation Detect message, the CN may switch the user plane from source RNC to target SRNC. If the SRNS Relocation is an inter SGSN SRNS relocation, the new SGSN sends Update PDP Context Request messages to the GGSNs concerned. The GGSNs update their PDP context fields and return an Update PDP Context Response. If the SRNS Relocation is an inter SGSN SRNS relocation, the new SGSN checks each individual MBMS service indicated by the MBMS contexts of the UE. If it is the first UE with this specific MBMS multicast service on this SGSN and this routing area, the SGSN determines the RNCs serving the routing area where the UE is located and requests for each the creation of an MBMS context on the GGSN and the establishment of GTP tunnels between the SGSN and the GGSN.
- 12) When the target SRNC receives the UTRAN Mobility Information Confirm message, i.e. the new SRNC—ID + S-RNTI are successfully exchanged with the MS by the radio protocols, the target SRNC shall initiate the Relocation Complete procedure by sending the Relocation Complete message to the new SGSN. The purpose of the Relocation Complete procedure is to indicate by the target SRNC the completion of the relocation of the SRNS to the CN.
- 13) Upon receiving the Relocation Complete message or if it is an inter-SGSN SRNS relocation; the Forward Relocation Complete message, the old SGSN sends an Iu Release Command message to the source RNC. When the RNC data-forwarding timer has expired the source RNC responds with an Iu Release Complete.
- 14) After the MS has finished the RNTI reallocation procedure and if the new Routeing Area Identification is different from the old one, the MS initiates the Routeing Area Update procedure. See subclause "Location Management Procedures (Iu mode only)". Note that it is only a subset of the RA update procedure that is performed, since the MS is in PMM-CONNECTED mode. New TMGI(s) may be allocated to the UE for MBMS services.

## 7.2.5 Service Deletion

### 7.2.5.1 MBMS RAB release

The MBMS RAB release is the same for both broadcast and multicast mode. The MBMS RABs are released by the RNC after a predefined period of receiving no data for a MBMS service.

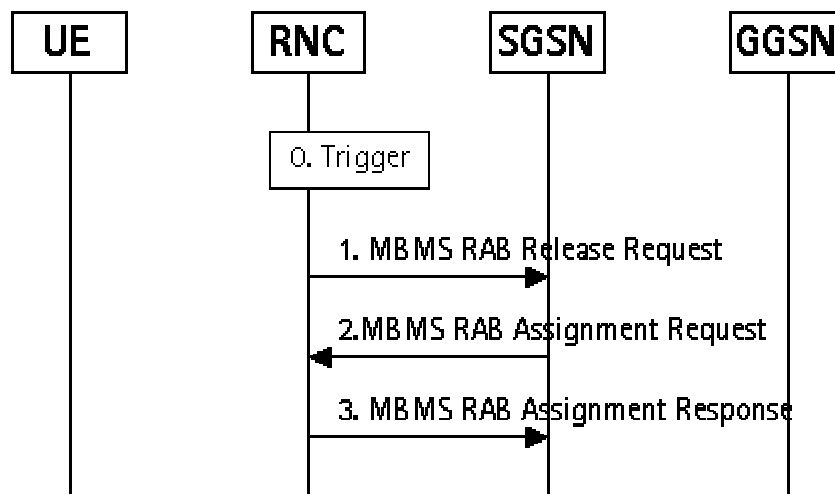
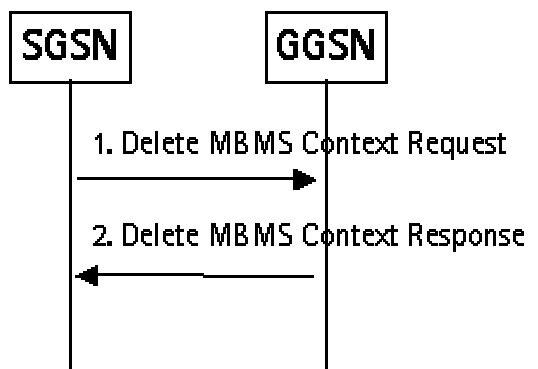

**Figure 46 MBMS RAB release**

- 0. After a predefined period of receiving no data for a particular MBMS service, the existing radio connections for the service are released by the RNC. The time period is defined by the operator.
- 1. RNC initiates RAB release procedure by sending an MBMS RAB Release Request message to SGSN, indicating RAB ID and a cause.
- 2. SGSN sends an MBMS RAB Assignment Request (RAB ID, cause) to RAN specifying RAB ID and cause.
- 3. RNC sends an MBMS RAB Assignment Response to SGSN, indicating RAB ID.

### 7.2.5.2 MBMS broadcast service deactivation

The MBMS broadcast service deactivation is local on the UE and local in the network. The user disables the reception of a data from a specific MBMS broadcast service. The broadcast deactivation procedure removes the MBMS broadcast contexts. The procedure is initiated by O&M.

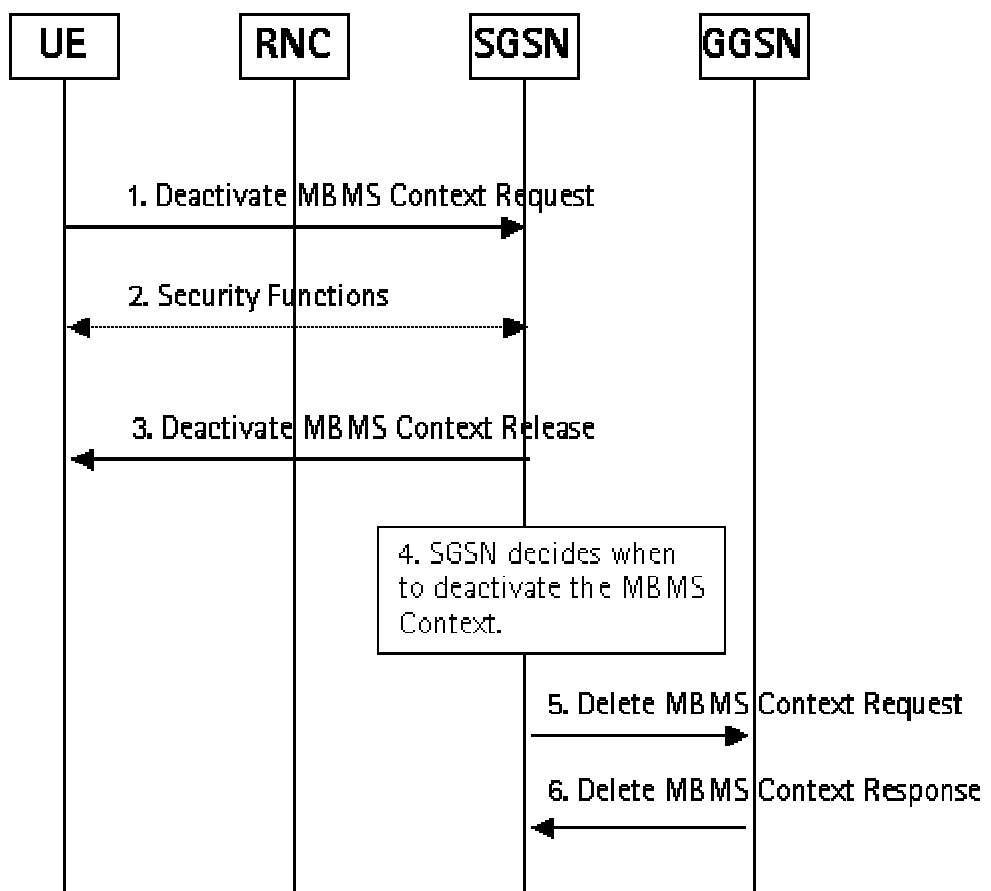

**Figure 47: MBMS broadcast service deactivation**

- 1. O&M initiates SGSN to start MBMS context deactivation procedure. SGSN sends Delete MBMS Context Request message to GGSN.
- 2. GGSN sends Delete MBMS Context Response message back to SGSN.

### 7.2.5.3 MBMS multicast service deactivation

The deactivation procedure removes user from a specific MBMS multicast service. The deactivation is a signaling procedure between UE and the network. It also removes the MBMS Context from the SGSN if the UE is the last member of the specific MBMS multicast service. The procedure may also produce a CDR for charging purposes.



**Figure 48: MBMS multicast service deactivation**

1. The UE sends Deactivate MBMS Context Request to the SGSN. The IP multicast address identifies the specific MBM multicast service, from which the UE wants the leave. An APN indicates a specific GGSN.
2. Security Functions may be performed, e.g. to authenticate the UE.
3. The SGSN sends an Activate MBMS Context Accept to the UE.
4. SGSN knows the numbers of RABs it has made for the particular service and the number of user which have joined to the service. When the last member of the service has left the service and all the RABs have been released the SGSN will start MBMS context deactivation.
5. SGSN initiates MBMS context deactivation by sending Delete MBMS Context Request message to GGSN. If this was the last GTP tunnel for this specific MBMS service on the GGSN, the GGSN removes its subscription to Multicast service over Gi.
6. GGSN sends Delete MBMS Context Response message back to SGSN.

## [7.2.6 Interfaces to External Media Sources](#)

### [7.2.7 Roaming](#)

### [7.2.8 Security](#)

### [7.2.9 Charging](#)

## 7.3 Option C)

### 7.3.1 MBMS Multicast Service Activation

#### 7.3.1.1 Multicast Service Activation

The following procedure enables a user to activate a multicast service by joining a multicast group. This procedure may also be used to periodically refresh the UEs group membership.

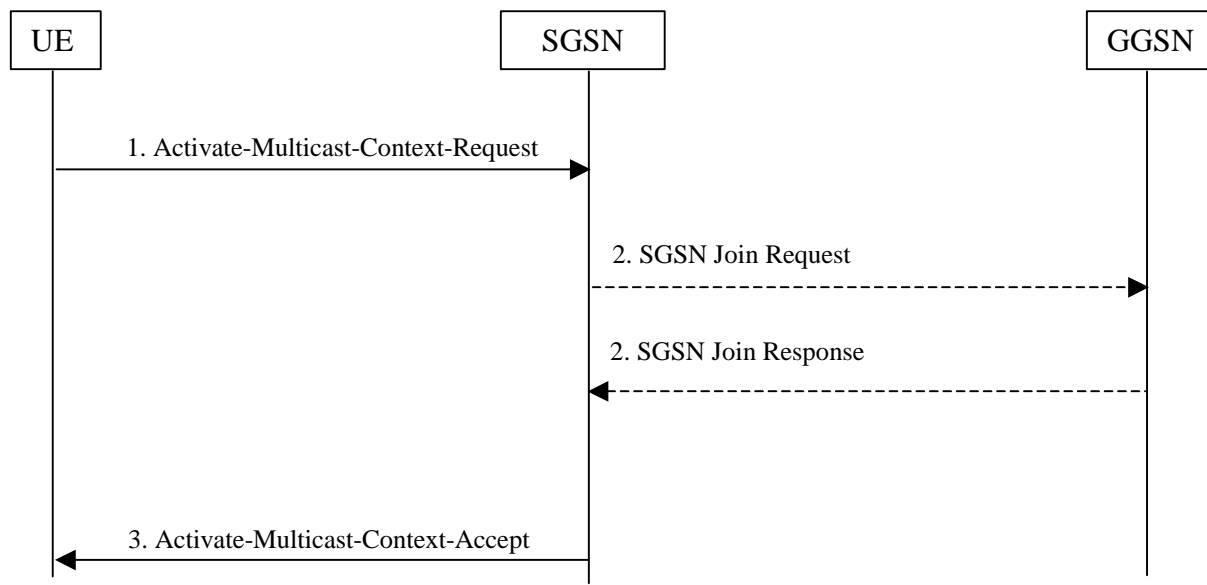

Figure 49.

1. UE Requests to join a specific multicast group and receive the associated service by sending an **Activate-Multicast-Context-Request** containing a multicast address and APN identifying the group. The message is sent to the SGSN currently serving the user. The U-SGSN checks for user authorization for joining the specific multicast group. If the user is authorized to join the requested multicast group, the SGSN returns an **Activate-Multicast-Context-Accept**. Alternatively, if the user is not authorized to join the service the U-SGSN returns an **Activate-Multicast-Context-Reject**.
2. If the SGSN has not done so previously, the SGSN notifies the GGSN identified by the APN and associated with the specific multicast service of its wish to receive transmissions associated with the service. by sending an **SGSN-Join-Request**. The GGSN responds with an **SGSN-Join-Response**.  
  
If the GGSN receives a SGSN request to join a given multicast service and a transmission for this service is ongoing, the GGSN should follow procedures described in 7.3.2 to set-up bearers and begin transmission.
3. The SGSN returns an **Activate-Multicast-Context-Response**. The **Activate-Multicast-Context-Response** might contain a deciphering key for multicast data and a refresh interval after which the UE is expected to repeat the activation procedure.

### 7.3.1.2 MS Initiated Multicast Service Deactivation

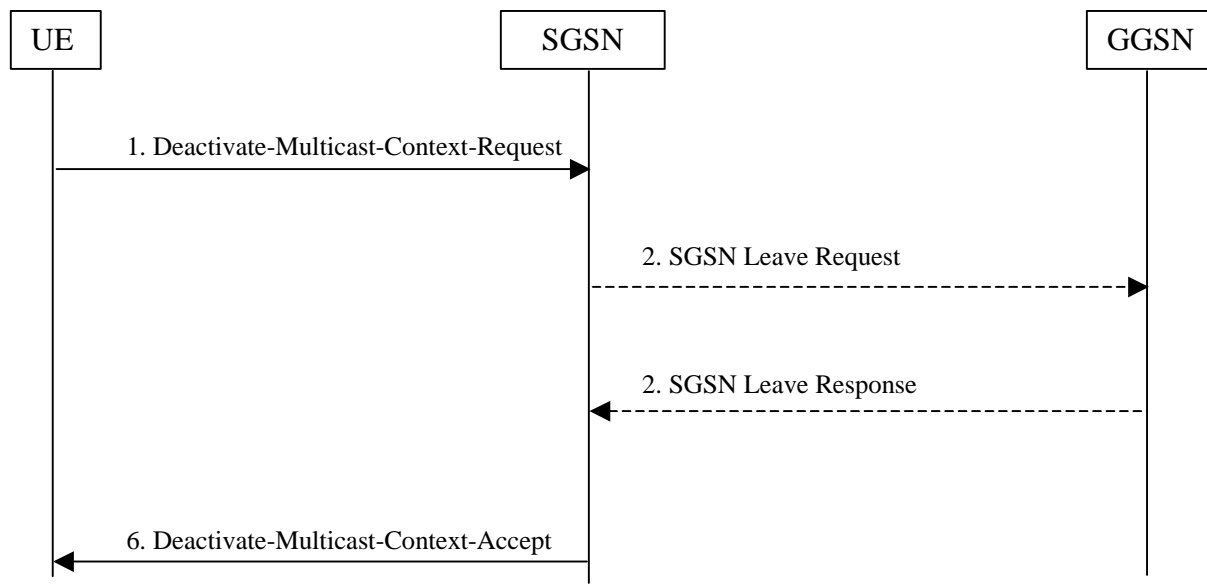

Figure 50.

1. UE Requests to leave a specific multicast group and cease reception of the associated service by sending a **Deactivate-Multicast-Context-Request** containing a multicast address and APN identifying the group. The message is sent to the SGSN currently serving the user. The SGSN checks if the user is currently a group member of the specified multicast group and returns a **Deactivate-Multicast-Context-Reject** if this is not the case.

If upon reception of a **Deactivate-Multicast-Context-Request**, the SGSN happens to be in the process of relaying multicast transmissions as part of the specified service to the RNC serving the UE, and the UE is the last known group member to be served by this RNC then the SGSN should terminate all service specific RABs to this RNC.

2. If at the time of reception of a **Deactivate-Multicast-Context-Request** the SGSN determines that no other UEs have joined the specific multicast group, the T-SGSN notifies the GGSN identified by the APN and associated with the specific multicast service of its wish to cease reception of transmissions associated with the service by sending an **SGSN-Leave-Request**. The GGSN responds with an **SGSN-Leave-Response**.

If the GGSN has any ongoing transmissions to the specific SGSN, it should terminate these transmissions and free the associated resources as described in section 7.2.3.

3. The SGSN returns a **Deactivate-Multicast-Context-Accept**.

### 7.3.1.3 SGSN Initiated Multicast Service Deactivation

SGSN initiated multicast service deactivation allows the SGSN to remove a UE from a designated multicast group.



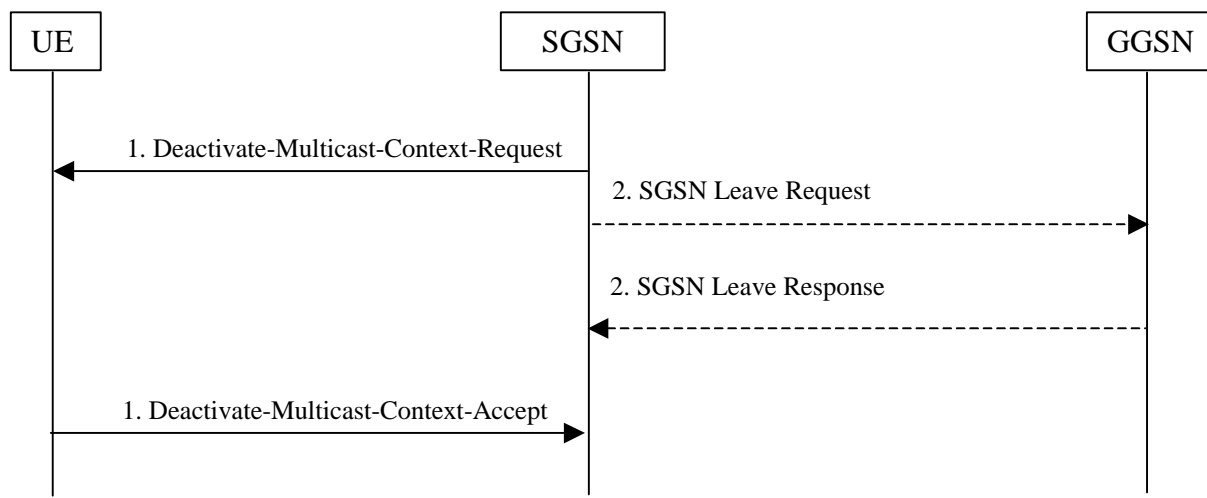

Figure 51

1. SGSN determines that a UE is to be removed from a designated multicast group (e.g. due to an on-line charging related event). The SGSN sends a **Deactivate-Multicast-Context-Request** containing a multicast address and APN identifying the group to the UE. The UE responds with an **Deactivate-Multicast-Context-Accept**.
2. The SGSN checks if apart from the deactivated UE, there are any other UEs that have joined the specific multicast group. If the SGSN is not aware of any other group members UEs, the SGSN sends an **SGSN-Leave-Request** to the GGSN identified by the multicast service APN. The GGSN responds with an **SGSN-Leave-Response**.

### 7.3.2 MBMS Broadcast Service activation

Broadcast service activation is not necessary for this option. Broadcast service activation is carried out locally, on the terminal when an application or user requests to receive data associated with a specific broadcast service.

### 7.3.3 MBMS RAB set-up

#### 7.3.3.1 Initiating an MBMS Transmission

The following procedure is used to initiate a transmission as part of an MBMS. The procedure is relevant to both broadcast and multicast services.

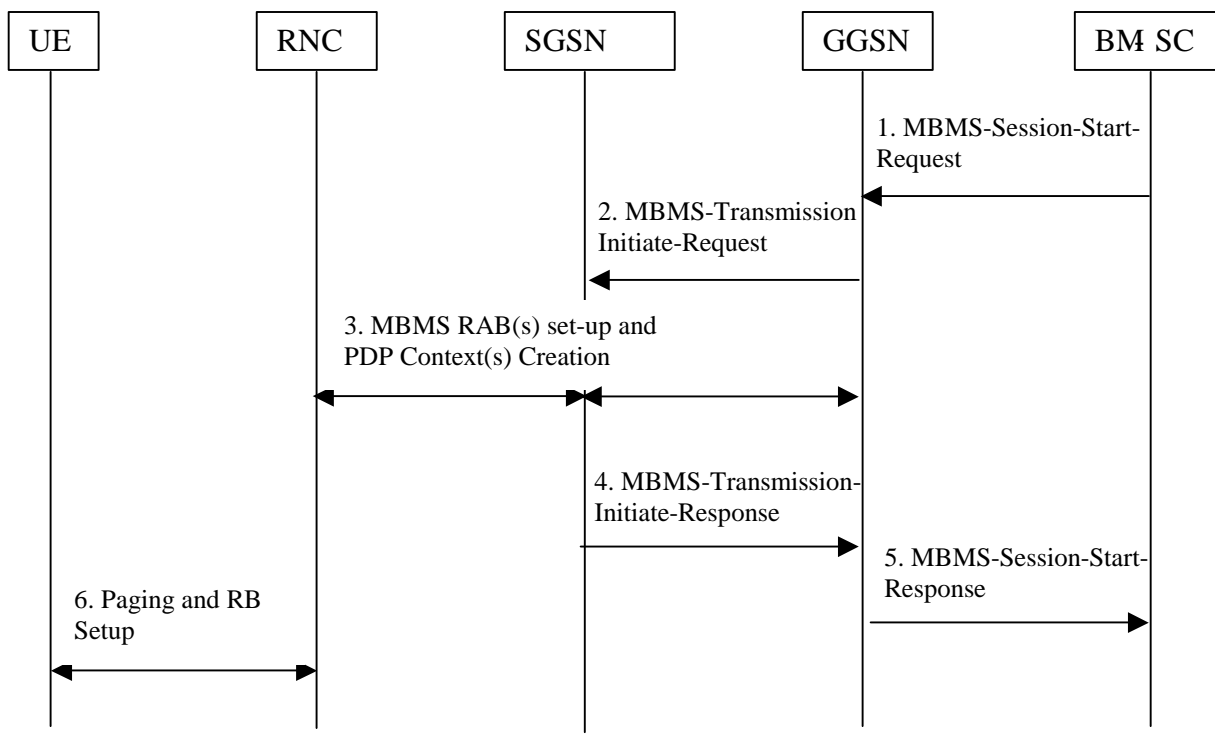

Figure 52. Initiating an MBMS Transmission

1. Upon content provider request, due to operator configuration or as part of a repetition scheme a BM-SC may wish to initiate a transmission over an MBMS bearer. In order to signal its wish to transmit and to request suitable quality-of-service for the coming transmission, the BM-SC sends an **MBMS-Session-Start-Request** to the GGSN assigned to the specific service.
2. The GGSN sends an **MBMS- Transmission-Initiate-Request** to all SGSNs which have requested to receive traffic associated with the service (as described in 7.3.1). The **MBMS-Transmission-Initiate-Request** includes service parameters received from the BM-SC in (1). For both broadcast and multicast transmissions the message is sent to SGSNs associated with the broadcast or multicast area.
3. Each SGSN requests the set-up of a suitable RAB(s) and GTP tunnels based on quality-of-service parameters as received in **MBMS-Transmission-Initiate-Request** from GGSN. The GTP tunnels are set-up towards the GGSN from which the **MBMS-Transmission-Initiate-Request** was received. RABs are set-up towards those RNCs that are serving UEs which have joined and are considered to be multicast group members.
4. Once RAB and GTP tunnel set-up is complete, the SGSN returns an **MBMS-Initiate-Transmission-Response** specifying whether the procedure was successfully completed and possibly detailing those areas where RAB setup has failed.
5. GGSN responds with **MBMS-Session-Start-Response**. The response indicates whether the bearers for transmission are available and if actual transmissions can start.
6. Actual paging of UEs and RB set-up procedures may be carried out, as RABs are set-up or at first packet arrival. This is currently left FFS.

### 7.3.3.2 Terminating an MBMS Transmission

The following procedure is used to terminate a transmission as part of an MBMS. The procedure is relevant to both broadcast and multicast services.

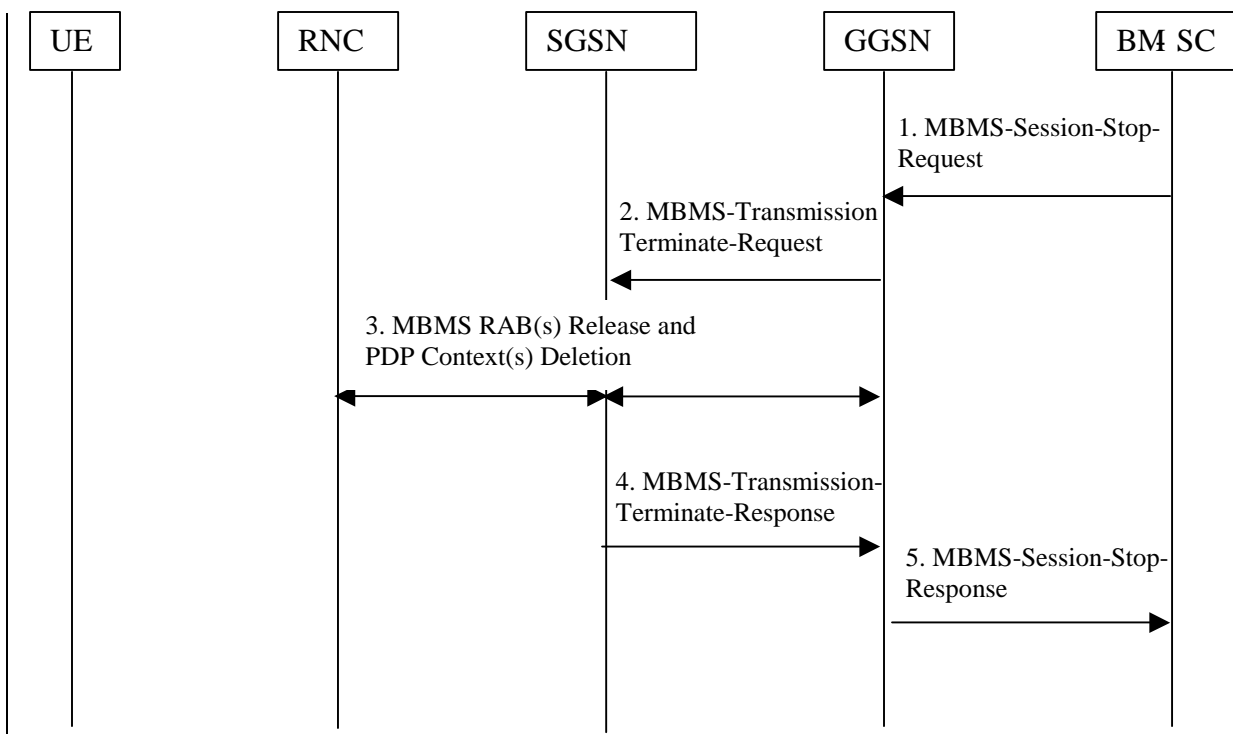

Figure 53. **Terminating an MBMS Transmission**

1. Upon content provider request, due to operator configuration or as part of a repetition scheme a BM-SC may wish to terminate a transmission over an MBMS bearer. In order to signal its wish terminate the transmission, the BM-SC sends an **MBMS-Session-Stop-Request** to the GGSN assigned to the specific service.
2. The GGSN sends an **MBMS- Transmission-Terminate-Request** to all SGSNs which are currently receiving traffic associated with the service (as described in 8.1.2).
3. Following **MBMS-Transmission-Terminate-Request**, each SGSN terminates the RAB(s) and GTP tunnels previously set-up for carrying out the transmission.
4. When all tunnels and RABs have been terminated, SGSN responds to the GGSN with an **MBMS-Transmission-Terminate-Response**.
5. GGSN responds with **MBMS-Session-Start-Response**.

### 7.3.4 Service Continuity and Mobility

Mobility procedures for MBMS are based on the following principles:

- During inter-SGSN procedures the messages that are used transfer a UE context from the old SGSN to the new SGSN (i.e. **SGSN Context Response** and **Forward Relocation Request**) shall include the MBMS contexts associated with the UE, identifying the multicast groups of which the UE is currently a member. It is expected that each such context shall be identified by an IP multicast address and APN.
- Based on received UE contexts, the new SGSN looks for MBMS contexts for which it has not previously joined and for each such context sends an **SGSN-Join-Request** to the GGSN identified by the service APN. The GGSN responds with **SGSN-Join-Response**. Likewise, for each MBMS context passed on to the new/target SGSN, the old/source SGSN checks whether any other UEs are members of the service identified by the context and if none are found sends an **SGSN-Leave-Request** to the GGSN identified by the APN.
- If for a specific multicast service, transmissions are ongoing and the UE that has just been relocated or has updated its location is the first multicast group member in the SGSN then the GGSN initiates MBMS bearers for the transmission associated with the service. Likewise, If for a specific multicast service, transmissions are ongoing and the UE that has just been relocated or has updated its location is the first multicast group member in the serving RNC then the SGSN initiates MBMS RABs for the transmission associated with the service.

- It is assumed that multicast service data can be carried on the Iu-r interface in situations where a UE's controlling RNC does not act as the serving RNC for any UEs that are multicast group members for the same service. As a result an RNC needs to be ready to receive multicast transmissions from the Iu-r and Iu-ps interfaces and be able to initiate/terminate the Iu-r interface transmissions in the absence/presence of an Iu-ps transmission for the same service.

Several cases of mobility procedures are provided below.

### 7.3.4.1 Inter-SGSN Routing Area Update

An SGSN routing area update may include MBMS specific exchanges for mobiles in PMM-IDLE state. Figure 54 illustrates an RA update initiated by a UE that has joined a multicast group.

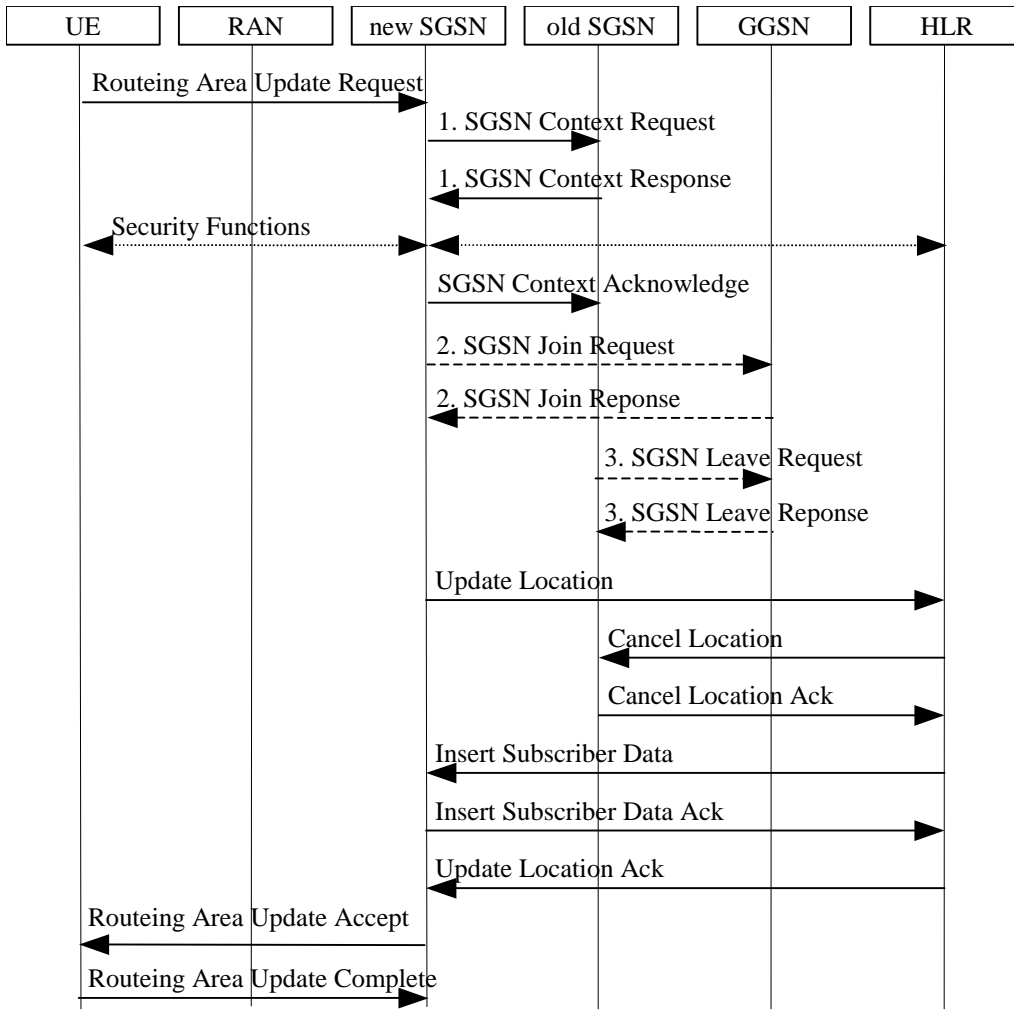

**Figure 54: MBMS exchanges during RA update procedure**

- After receiving the **Routing Area Update Request**, the new SGSN requests the UE's context from the old SGSN by sending an **SGSN-Context-Request**. After validation the old SGSN responds with an **SGSN-Context-Response** that beyond the MM context and PDP contexts of the UE includes the list of MBMS contexts identifying the multicast services to which the UE is joined. Each such service is identified by an APN and an IP multicast address.
- Upon reception of UE contexts including PDP contexts and MBMS contexts the new SGSN updates associated GGSN contexts. For each MBMS context that the SGSN has not previously joined (due to lack of other group members in its domain) the SGSN sends an **MBMS-Join-Request** to the GGSN identified by the APN associated with the MBMS context. The GGSN responds with an **SGSN-Join-Response**.

If the SGSN is already receiving a transmission associated with any of the multicast services to which the UE is joined and the UE is the first group member to access this service through a new RNC then the SGSN initiates the set-up of MBMS RABs towards this RNC.

If any transmissions are ongoing for the multicast service the GGSN will initiate the transmission bearers by sending an **MBMS-Transmission-Initiate-Request** immediately after responding with the **SGSN-Join-Response**.

3. Upon reception of **SGSN-Context-Acknowledge** the old SGSN checks if there are still multicast group members for each of the services identified by the UEs MBMS contexts. For each service with no remaining member UEs the SGSN sends an **SGSN-Leave-Request** to the GGSN identified by an APN in the MBMS context.

### 7.3.4.1 Serving RNS Relocation Procedure

An inter-SGSN SRNS relocation procedure may include MBMS specific exchanges for mobiles in PMM-CONNECTED state. Figure 55 illustrates an RA update initiated by a UE that has joined a multicast group.

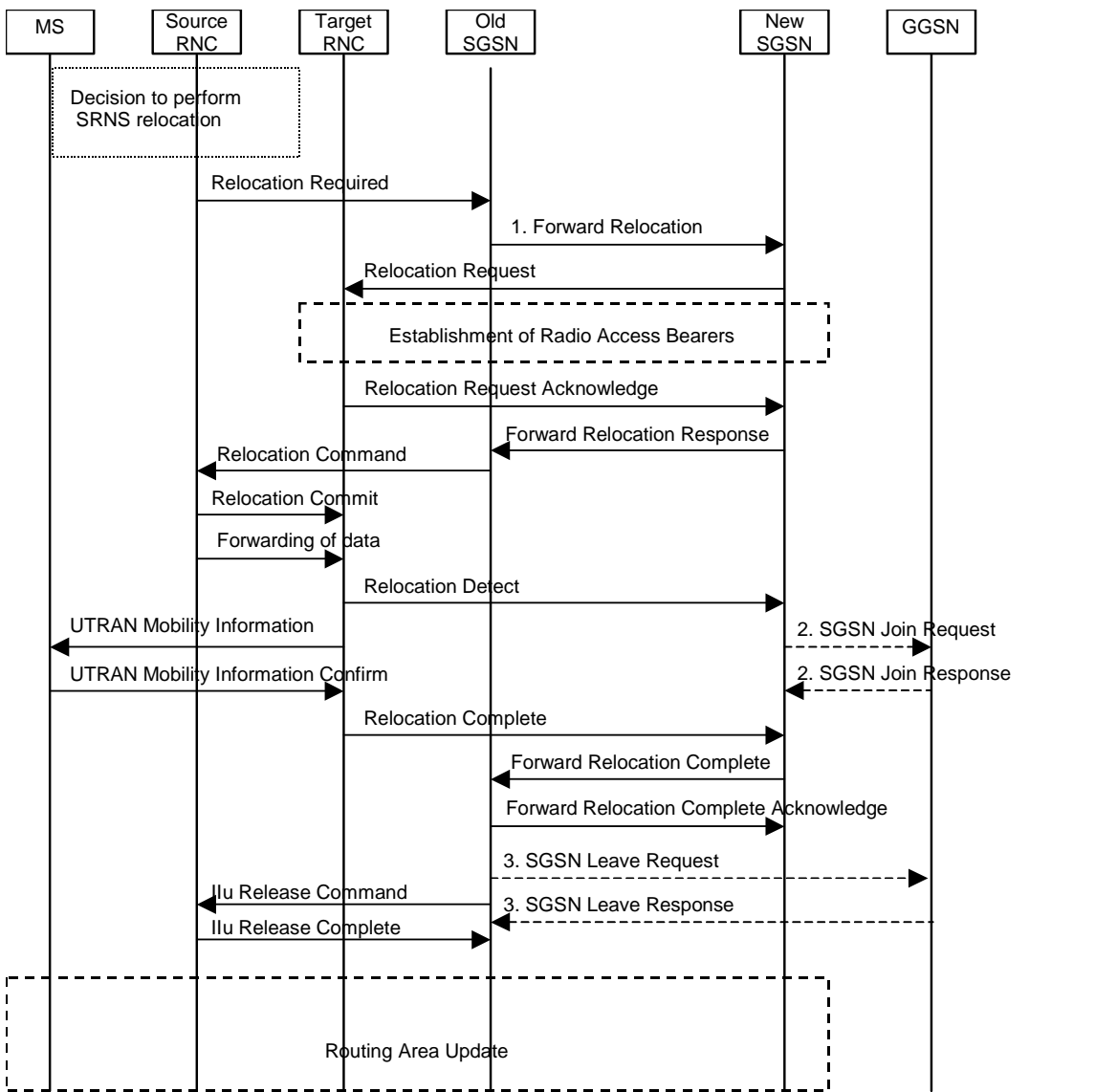

**Figure 55: MBMS exchanges in SRNS relocation procedure**

1. After receiving the Relocation Required indication from the source RNC, the old SGSN transfers UE's context by sending a **Forward Relocation** message to the new SGSN. Beyond the MM context and PDP contexts of

the UE the **Forward Relocation** includes the list of MBMS contexts identifying the multicast services to which the UE is joined. Each such service is identified by an APN and an IP multicast address.

2. Upon reception of the **Relocation Detect** message the new SGSN uses PDP contexts and MBMS contexts received in (1) to update associated GGSN contexts. For each MBMS context that the SGSN has not previously joined (due to lack of other group members in its domain) the SGSN sends an **MBMS-Join-Request** to the GGSN identified by the APN associated with the MBMS context. The GGSN responds with an **SGSN-Join-Response**.

If the SGSN is already receiving a transmission associated with any of the multicast services to which the UE is joined and the UE is the first group member to access this service through a new RNC then the SGSN initiates the set-up of MBMS RABs towards this RNC.

If any transmissions are ongoing for the multicast service the GGSN will initiate the transmission bearers by sending an **MBMS-Transmission-Initiate-Request** immediately after responding with the **SGSN-Join-Response**.

3. Following reception of **Forward Relocation Complete** the old SGSN checks if there are still multicast group members for each of the services identified by the UEs MBMS contexts. For each service with no remaining member UEs the SGSN sends an **SGSN-Leave-Request** to the GGSN identified by an APN in the MBMS context.

### 7.3.5 Service Deletion

### 7.3.6 Interfaces to External Media Sources

### 7.3.7 Roaming

### 7.3.8 Security

### 7.3.9 Charging

### 7.4 Void

## 7.5 Option E

### 7.5.1 Multicast architecture

This option supports the following principles for the Control Plane:

#### UTRAN principles:

In order to allow the RNC to manage the UTRAN UE mobility for MBMS service as well as for non-MBMS services, a MBMS specific context shall exist in the RNC for each UE activating a MBMS: one RAB establishment procedure shall be done for each UE activating a multicast MBMS service.

#### CN principles:

A separate control plane shall be used on Gn/Gp for each UE with an active MBMS connection. A shared user-plane may be applied to all UEs in the same SGSN.

#### BM-SC principles:

BM-SC is the reference for the service related information (Qos, MBMS area,...) of the Broadcast and Multicast services.

Hence,

- BM-SC is responsible for the service area mapping between service area as seen by the content provider (e.g. "greater London") and the Broadcast / Multicast distribution areas as handled by the PS domain.
- MBMS Broadcast services are activated from BM-SC to the Network
- For Multicast services GGSN gets the parameters (Qos, BM-area,...) of the Multicast service from BM-SC and gives them back to the SGSN in PDP context activation accept
- As opposed to data in HLR that deal with the definition of each individual MBMS service, data in HLR associated with MBMS specify the rights of an individual user with regard to MBMS service in general: e.g. max QoS of multicast services for a given user... it is FFS whether it checks the right to benefit from multicast services, and the right to benefit from multicast service while roaming.

This option supports the following principles for the User Plane:

#### UTRAN principles:

In order to save resources over Iu, an Iu user plane between a RNC and a SGSN can be shared between UEs for the transport of data for the UEs that have activated the same MBMS multicast service.

Iur/SRNC/CRNC roles: remain open until UTRAN has made a decision.

#### CN principles:

There is per MBMS service one GTP user plane going down from a GGSN to a SGSN, and this regardless of the number of RNCs that are in the SGSN area and that need to receive the traffic for this MBMS service. User plane between a SGSN and a RNC can also be shared between users activating the same service.

Due to UTRAN architecture choice for MBMS, it is still open whether MBMS multicast user plane shall go towards the SRNC or CRNC. MBMS Multicast user plane may be needed by the RNC to which the UE attached or by the RNC under which the UE roams. This is FFS.

Due to this UTRAN architecture choice, user plane establishment can be done:

- At UE service activation
- Independently of UE service activation (before or after)

[This is FFS and linked to UTRAN architecture choice.](#)

### 7.5.1.1 MBMS Multicast Service Activation

[The activation procedure registers the user in the network to enable the reception of data from a specific MBMS multicast service. The activation is a signalling procedure between the UE and the network. The procedure is similar to the PDP context activation with the addition that user planes can be optimised to share resources between UEs that activate the same MBMS multicast service.](#)

[The MBMS Multicast Service Activation registers the user for a multicast service to enable the reception of data from this MBMS multicast service. Whether it establishes the MBMS data transfer path within the Core network is FFS according to UTRAN architecture choice and needs. The procedure is similar to the PDP context activation and implies the use of the same TI parameter.](#)

[The activation of an MBMS multicast service may follow an explicit user interaction on the UE or may be done automatically by the UE without user interaction \(e.g. done automatically at attach upon data pre-configured by the user on its terminal\). Such description of UE behaviour is out of the scope of this document.](#)

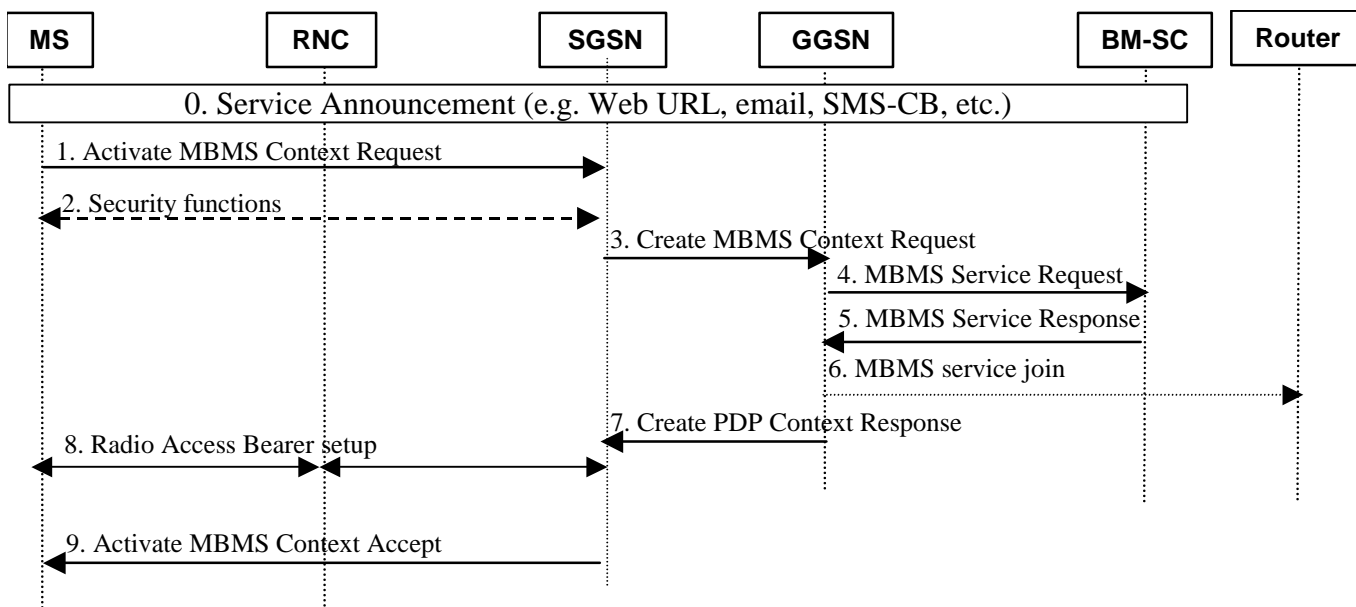

**Figure 56: MBMS multicast mode service activation: MBMS context activation**

0. [MBMS service discovery phase: UE learn or are notified about MBMS services through agreed methods: SMS-CB, SMS-PP, Web-URL, etc. The announcement of the MBMS multicast service provides IP multicast address and APN. A MBMS service is identified by these 2 parameters. Which other parameters are required is FFS.](#)
1. [UE that wants to join/activate a MBMS multicast session sends an Activate MBMS Context Request to SGSN, providing a Transaction Identifier \(as per Point to Point PDP context activation\), the IP multicast address of the MBMS service it requires. The UE does not provide a QoS. UE has learned these addresses during the MBMS service discovery phase. The APN is a standard value that depicts “access to any MBMS multicast service”. Which other parameters are required is FFS. The SGSN creates a UE specific MBMS context which stores the parameters of the activated MBMS multicast service](#)
2. [Security functions may be performed. Security is only UMTS current security function without MBMS service security.](#)



3. SGSN checks the activation request (e.g. whether the UE is allowed to benefit from PDP contexts towards a APN) and sends a Create MBMS Context request to GGSN. If there is no user plane already established for this service, then a new GTP user plane for this MBMS service may (FFS) be established. .
4. GGSN sends MBMS Service Request to BM-SC to request MBMS service information like e.g. QoS and MBMS service area. It is FFS while the message provides an identifier of the UE joining the service, e.g. MSISDN
5. BM-SC acknowledges this request by sending a MBMS Service Response, indicating the MBMS service information.
6. This GGSN may (FFS) send a MBMS service join message over Gi, in order to join the MBMS session provided by BM-SC (FFS as subject to change according to UTRAN architecture decision). This message may be based on existing IETF multicast protocols, as MLD, IGMP, PIM, etc.
7. The GGSN sends a confirmation of the Create MBMS Context request to SGSN. It provides the SGSN with MBMS service information (e.g. QoS,...).
8. The SGSN may send a RAB assignment request to the RAN in order to establish the MBMS specific context for the UE in the RAN. It is up to the SGSN to decide whether this RAB shall be established at service activation or when DL PDU will be received. Iu user plane for many users activating the service between a SGSN and a RNC may be done (FFS).
9. The UE receives a Activate MBMS Context Accept message (service id). Service id is the identifier of the MBMS service used by the SGSN when e.g. it needs to page the mobile for this MBMS service. The Service Id is linked to a service and allows the mobile to receive the paging even in case of change of SGSN. Which other parameters are needed is FFS.

Note: In steps 3, 6 and 8, user plane may be established over Gi, Gn and Iu interface. This user plane establishment is FFS as it is conditioned by MBMS architecture decision taken in UTRAN group concerning SRNC/CRNC/Iur roles. But when established, these user planes are shared between users requesting the same service.

### 7.5.1.2 MBMS Multicast Service De-activation

Leaving is the process by which a user informs the network that it does no longer expect to receive Multicast data. When the UE expects to leave a Multicast service, it shall send a deactivation request to the SGSN. The deactivation is a signalling procedure between the UE and the network similar to the PDP context deactivation procedure with the addition that optimised user plane can be kept as shared by many users requesting the multicast service.

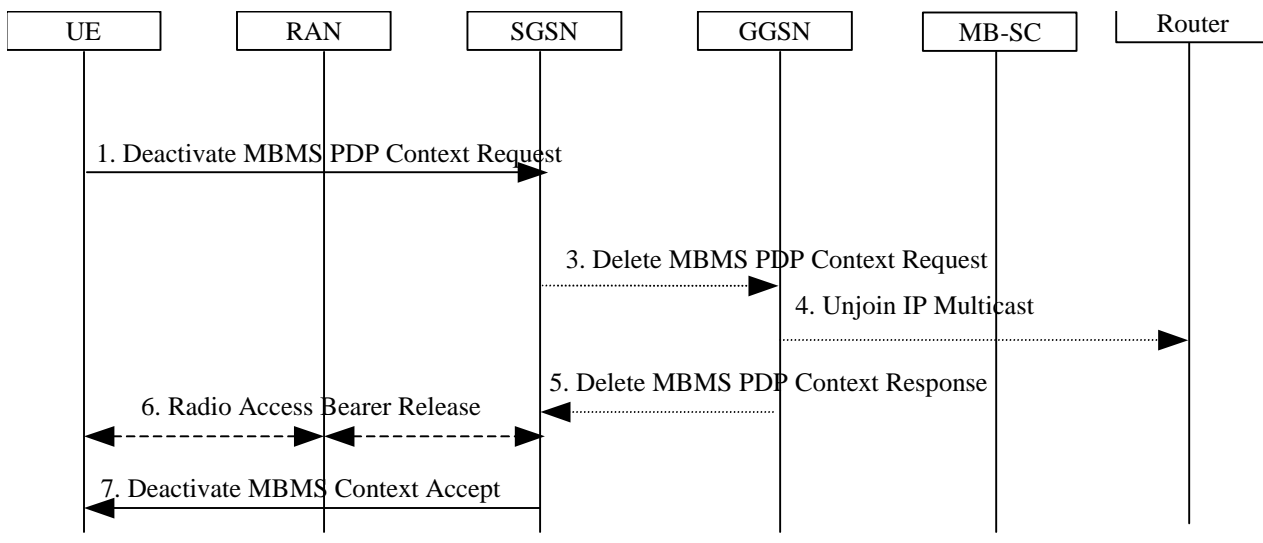

**Figure 57: MS Initiated Multicast service deactivation**

- 1) The UE sends a Deactivate MBMS PDP Context Request message to the SGSN.
- 3) The SGSN sends a Delete MBMS PDP Context Request message to the GGSN.
- 4) If it is the last UE using the MBMS service, the GGSN may (FFS) remove its subscription to multicast service over Gi. Gn user plane resources may (FFS) are also be free if the UE was the last UE using the service between this SGSN and the GGSN.
- 5) The GGSN returns a Delete PDP Context response message to the SGSN.
- 6) The SGSN requests a RAB de-assignment for this UE to remove MBMS context for the UE in the RNC. Iu user plane resources may be removed (FFS) if the UE is the last UE using this service between the RNC and the SGSN.
- 7) The SGSN returns a Deactivate MBMS PDP Context Accept message to the UE.

Note: In steps 4 and 6, user plane may be removed over Gi, Gn and Iu interface. This user plane removal is FFS as it is conditioned by MBMS architecture decision taken for UTRAN concerning SRNC/CRNC/Iur roles. As the user plane is shared by many users, it can't be removed before the service is deactivated for all the users.

### 7.5.1.3 Multicast DL data transfer

User planes (Gi, Gn and Iu) for Multicast service data transfer have to be established before data can be transferred. The following description applies when user plane have been established.

Establishment of user plane is FFS as it is conditioned by MBMS architecture choice done for UTRAN.

#### 7.5.1.3.1 Multicast DL data transfer

If the MBMS user plane is established for the UE, the SGSN can forward MBMS data to that UE.

When the UE is in RRC CONNECTED in the RNC, the internal RNC state can be either CELL\_DCH or CELL\_FACH state or PCH state. Each RNC knows which UEs are interested in a MBMS service. When DL PDU of a MBMS service is received in the RNC, the interested UEs shall be in RRC DCH or FACH state so that the RNC can transfer DL data.

The overall MBMS DL data transfer is presented in the following figure:

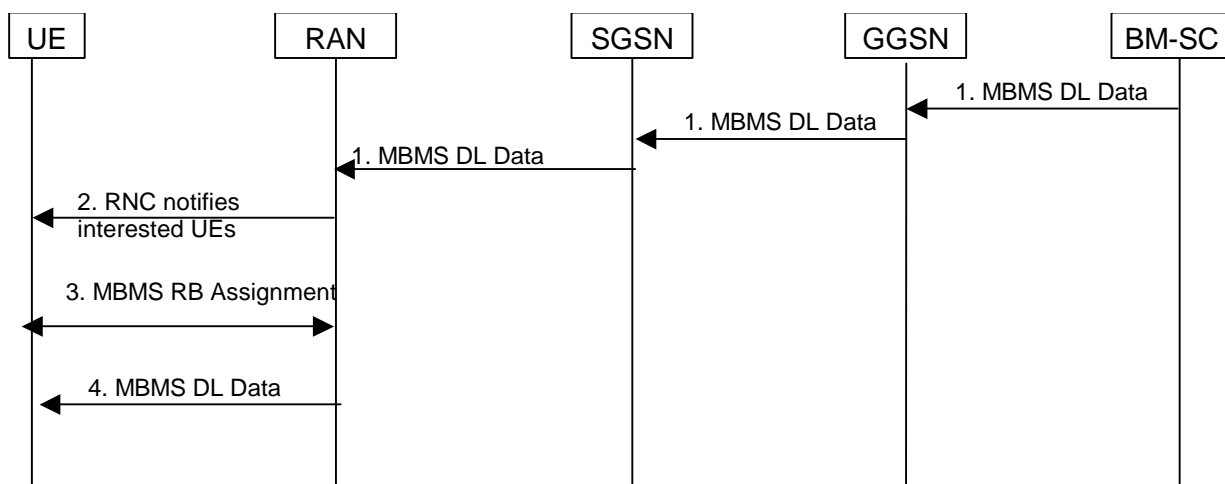

**Figure 58: MBMS DL Data transfer when MBMS user plane is established**

1. The BM-SC sends MBMS data to the appropriate GGSN. The GGSN transfers DL data to the SGSNs with which a user plane is established. User plane optimisation can be done between the SGSNs and the GGSN.
2. The SGSN forwards DL MBMS data to the RNCs with which a user plane is established. User plane optimisation can be done between the RNCs and the SGSN.
3. The RNC knows which UEs are interested in the MBMS service. The RNC notifies all the interested UEs of incoming MBMS data. For UE interested in the service but in PCH state, the RNC shall send a notification in order to get them to RRC Cell Connected state. Whether these two notifications can be a single notification is FFS and subject to RAN2 studies. The fact that the interested UEs change state with or without responding to the notification is also FFS and left to RAN2 studies due to potential impact on the radio interface.
4. The RNC establishes the needed radio resources for the concerned UEs.
5. The RNC sends DL MBMS data in the concerned cells.

Note that it may be that control plane references are not available (e.g. RAB release was used after some timer has expired in UTRAN). In this case RAB may be re-established if the UTRAN has no more MBMS information for the UE.

Due to a potential important number of Ues, a potential important number of ServiceRequest (response to paging) can be received by the SGSN and an important number of RAB establishment request will have to be treated by the SGSN/RNC.

Nevertheless, as each mobile responds to a paging request in an independent way, the Service Request messages and the RAB establishment will not be simultaneous.

Decision to assign the RAB at service activation and delay before releasing a RAB is implementation dependent as this does not save radio resources while it brings additional procedures to be handled.

#### 7.5.1.3.2 Multicast DL data transfer in case of Iu Flexibility

As a user plane path is established for each UE activating the MBMS service, when two UEs are on the same RNC but attached to different SGSNs due to Iu Flexibility, a user plane is established for the first UE between the first SGSN and the RNC and another user plane is established for the second UE with the other SGSN and the same RNC.

As a consequence, the RNC will receive MBMS data from two SGSNs for the two UEs and has to drop the duplicated data.

This corresponds to Option 3 of Iu Flexibility options.

The following figure shows how DL MBMS data is transferred to the interested UEs:

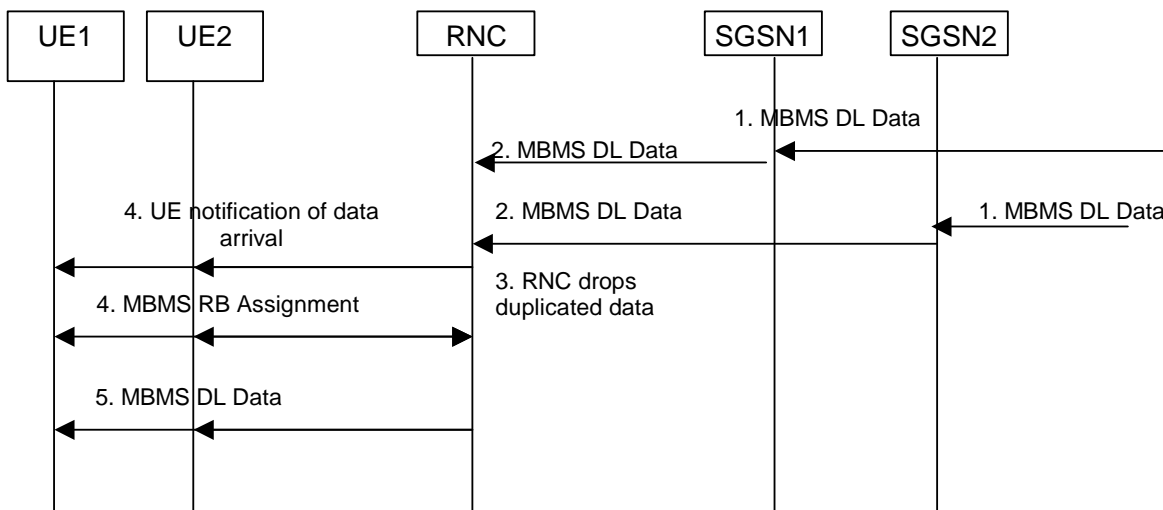
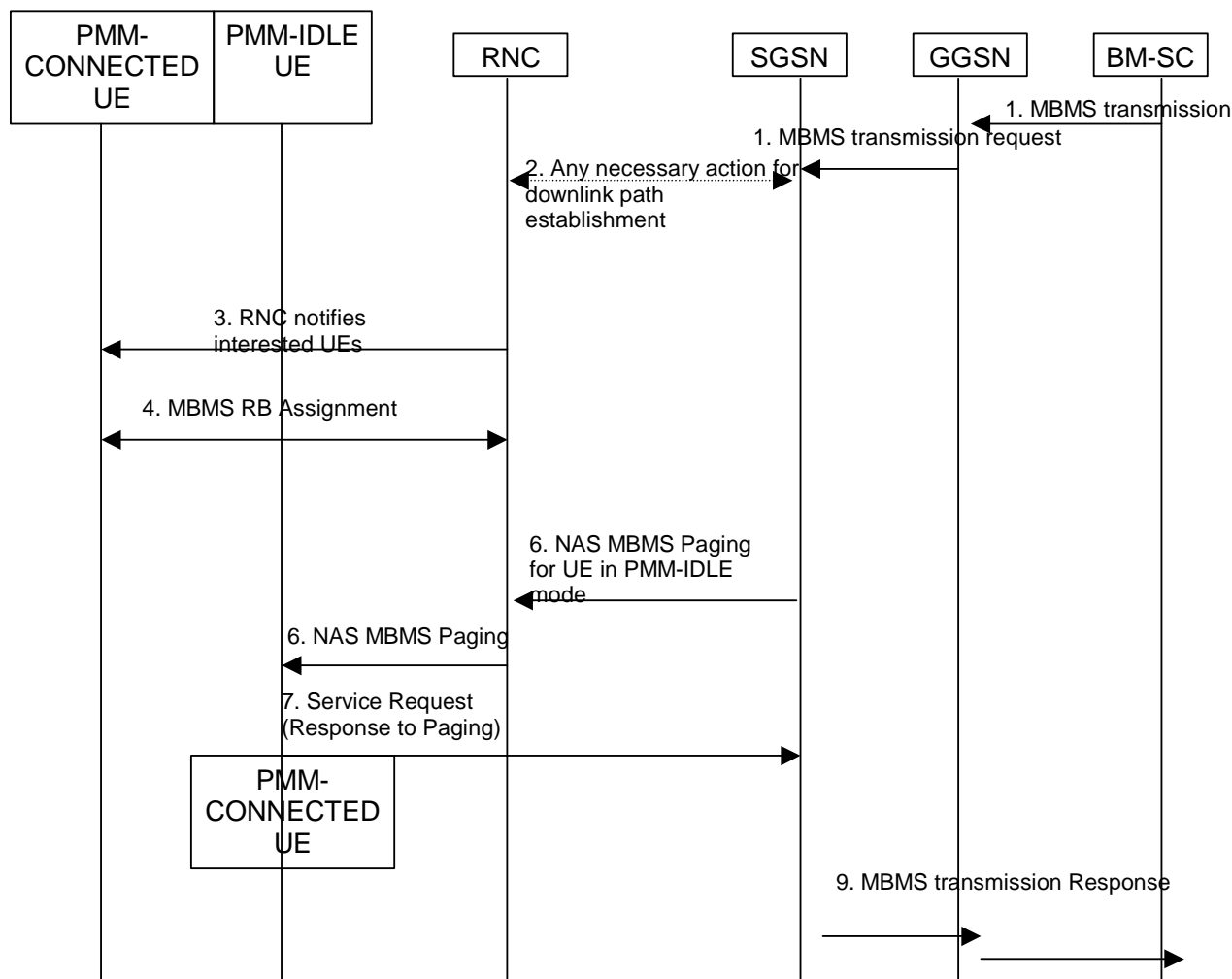

**Figure 59: Downlink data transfer in case of Iu Flexibility**

### 7.5.1.3.3. Optional MB-SC notification before MBMS data transfer

In order to avoid data bufferization or data dropping in the UMTS network, a BM-SC may send a message indicating to the UMTS network that it wishes to transmit MBMS data.

This option may not be used by the BM-SC. In this case the GGSN receives MBMS data without previous notification and forwards the data to the SGSN that may either drop the data or bufferizes them until a bearer path is established. It is up to the BM-SC to send “non-critical” data prior to real MBMS service data in this case, for example: use or advertisement data or pre-amble data.



**Figure 60: Optional MB-SC notification before MBMS data transfer**

1. The BM-SC may indicate the UMTS network of the need to prepare UMTS bearer prior to MBMS data arrival through a request sent to the GGSN and relayed to the SGSN.
2. The SGSN establishes RAB for UE in PMM-CONNECTED states if the RAB has not been assigned or has been released for the UE.
3. The RNC knows which UEs are interested in the MBMS service. The RNC notifies all the interested UEs of incoming MBMS data. For UE interested in the service but in PCH state, the RNC shall send a notification in order to get them to RRC Cell Connected state. Whether these two notifications can be a single notification is FFS and subject to RAN2 studies. The fact that the interested UEs change state with or without responding to the notification is also FFS and left to RAN2 studies due to potential impact on the radio interface.
4. The RNC establishes the needed radio resources for the concerned UEs.
5. The SGSN initiates a NAS MBMS Paging procedure for the UEs in PMM-IDLE state with the RNCs covering the last known RA of these UEs. NAS Paging indicates the service identifier as paging target.
6. The UEs in PMM-IDLE state respond to the NAS Paging with a Service Request (Response to Paging) forwarded to the SGSN. The UEs state is changed to PMM-CONNECTED state.

7. For each UE that have responded to the MBMS Paging, security function may be executed, the SGSN establishes a RAB with the RNC.

8. The SGSN informs the BM-SC that MBMS transmission can start.

Note: user plane establishment is FFS as it is linked to UTRAN architecture decision as for service activation procedure.

#### 7.5.1.3.4 Multicast DL data transfer to UE in PMM-CONNECTED and PMM-IDLE mode

The RNC can initiate RAB release. It initiates as many RAB releases as there are RABs established for the same MBMS service.

RAB Release could apply for both Multicast and Broadcast MBMS Modes. RAB Release is a UTRAN decision. There is no specificities for RAB Release procedure compared to a non MBMS point-to-point RAB except that that user plane are removed only when all Control Plane are removed.

UE in PMM-IDLE mode are paged before associated RAB can be assigned and data can be transferred.

#### 7.5.1.4 Service continuity and Mobility

##### 7.5.1.4.1 MBMS Relocation and Handover

When a UE in PMM-CONNECTED state changes of SGSN due to SRNS relocation or handover procedure:

- its MBMS contexts are transferred from the old to the target SGSN with other UE contexts (GMM and point-to-point PDP contexts)
- The Target SGSN re-assigns the UE's point-to-point RABs and the UE's MBMS data paths if not already established (Iu user plane can be optimised).
- The Target SGSN updates the UE's PDP contexts with the appropriate GGSNs and UE's MBMS PDP contexts. Gn user plane can be optimised.

This is described in the figure below for the relocation procedure. This figure and the associated text is issued from a normal relocation procedure with addition (in bold) of MBMS specificities. Note that some details of the relocation procedure are not shown for simplification.

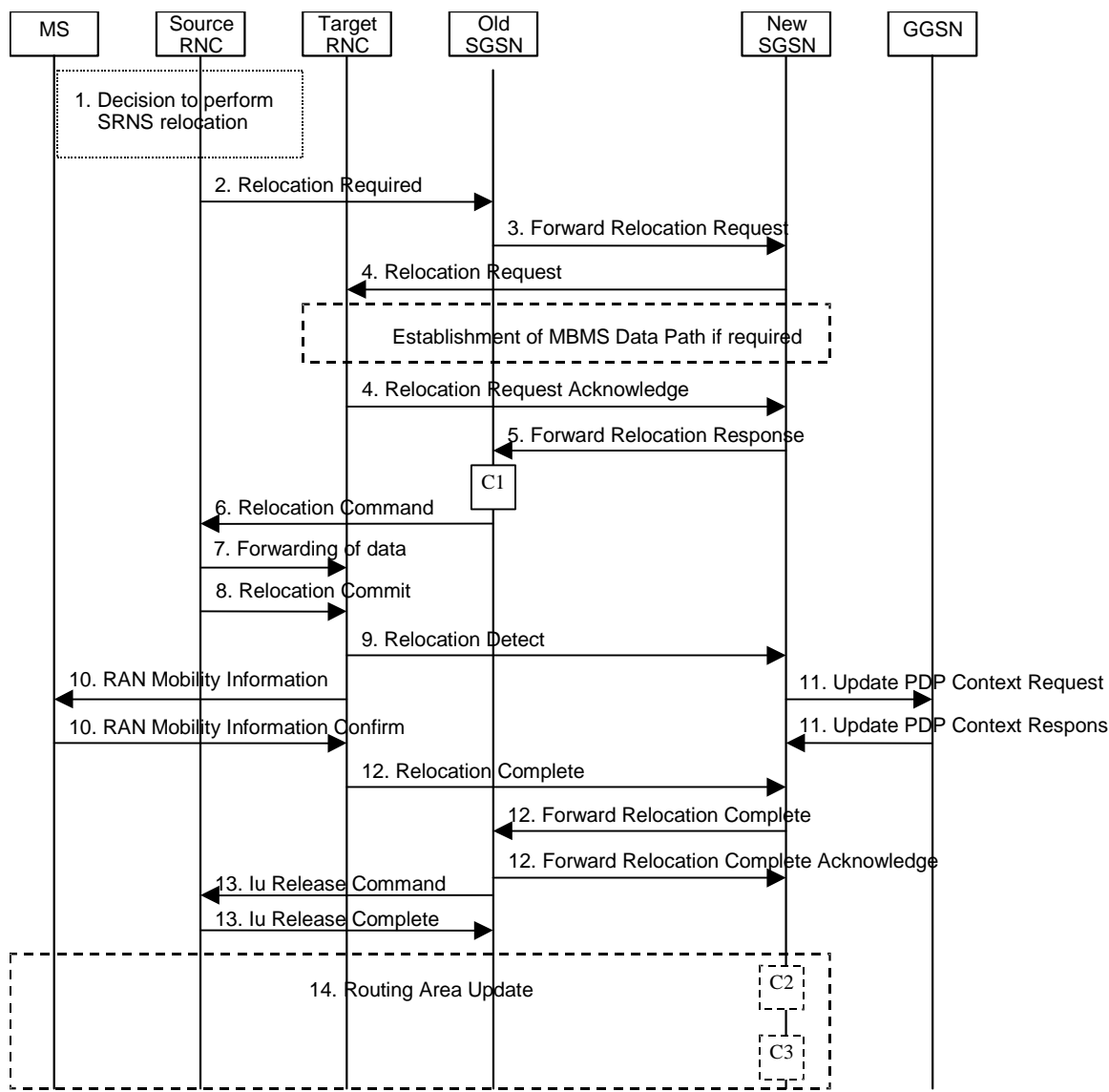

**Figure 61: SRNS Relocation Procedure**

- 1) [The source SRNC decides to perform/initiate SRNS relocation.](#)
- 2) [The source SRNC sends a Relocation Required message \(Relocation Type, Cause, Source ID, Target ID, Source RNC to target RNC transparent container\) to the old SGSN. The source SRNC shall set the Relocation Type to "UE not involved". The Source SRNC to Target RNC Transparent Container includes the necessary information for Relocation co-ordination, security functionality and RRC protocol context information \(including MS Capabilities\).](#)
- 3) [The old SGSN determines from the Target ID if the SRNS Relocation is intra-SGSN SRNS relocation or inter-SGSN SRNS relocation. In case of inter-SGSN SRNS relocation, the old SGSN initiates the relocation resource allocation procedure by sending a Forward Relocation Request message \(IMSI, Tunnel Endpoint Identifier Signalling, MM Context, PDP Context, MBMS context, Target Identification, UTRAN transparent container, RANAP Cause\) to the new SGSN. If required, the PDP context contains GGSN Address for User Plane and Uplink TEID for Data \(to this GGSN Address and Uplink TEID for Data the old SGSN and the new SGSN send uplink packets\). At the same time a timer is started on the MM and PDP contexts in the old SGSN. The Forward Relocation Request message is applicable only in the case of inter-SGSN SRNS relocation.](#)
- 4) [The new SGSN sends a Relocation Request message \(Permanent NAS UE Identity, Cause, CN Domain Indicator, Source-RNC to target RNC transparent container, RABs to be setup\) to the target RNC. This includes point-to-point and MBMS RABs. Only the Iu Bearers of the RABs are setup between the target RNC and the](#)

new-SGSN as the existing Radio Bearers will be reallocated between the MS and the target RNC when the target RNC takes the role of the serving RNC. Iu user plane optimization can take place for MBMS RABs used by many UEs. After all necessary resources for accepted RABs including the Iu user plane are successfully allocated; the target RNC shall send the Relocation Request Acknowledge message (RABs setup, RABs failed to setup) to the new SGSN. For each RAB to be set up, the target RNC may receive simultaneously downlink user packets both from the source SRNC and from the new SGSN. This may not apply for MBMS RABs, FFS

- 5) When resources for the transmission of user data between the target RNC and the new SGSN have been allocated and the new SGSN is ready for relocation of SRNS, the Forward Relocation Response message (Cause, RANAP Cause, and RAB Setup Information) is sent from the new SGSN to old SGSN. This message indicates that the target RNC is ready to receive from source SRNC the forwarded downlink PDUs, i.e. the relocation resource allocation procedure is terminated successfully. The Forward Relocation Response message is applicable only in case of inter-SGSN SRNS relocation.
- 6) The old SGSN continues the relocation of SRNS by sending a Relocation Command message (RABs to be released, and RABs subject to data forwarding) to the source SRNC. The old SGSN decides the RABs to be subject for data forwarding based on QoS, and those RABs shall be contained in RABs subject to data forwarding. **This may not apply for MBMS RABs, FFS**
- 7) The source SRNC may, according to the QoS profile, begin the forwarding of data for the RABs to be subject for data forwarding.
- 8) Before sending the Relocation Commit the uplink and downlink data transfer in the source, SRNC shall be suspended for RABs, which require delivery order. The source RNC shall start the data-forwarding timer. When the source SRNC is ready, the source SRNC shall trigger the execution of relocation of SRNS by sending a Relocation Commit message (SRNS Contexts) to the target RNC over the Iur interface. The purpose of this procedure is to transfer SRNS contexts from the source RNC to the target RNC, and to move the SRNS role from the source RNC to the target RNC. SRNS contexts are sent for each concerned RAB and contain the sequence numbers of the GTP-PDUs next to be transmitted in the uplink and downlink directions and the next PDCP sequence numbers that would have been used to send and receive data from the MS.
- 9) The target RNC shall send a Relocation Detect message to the new SGSN when the relocation execution trigger is received. For SRNS relocation type "UE not involved", the relocation execution trigger is the reception of the Relocation Commit message from the Iur interface. When the Relocation Detect message is sent, the target RNC shall start SRNC operation.
- 10) The target SRNC sends a UTRAN Mobility Information message. This message contains UE information elements and CN information elements. The UE information elements include among others new SRNC identity and S-RNTI. The CN information elements contain among others Location Area Identification and Routing Area Identification. The procedure shall be co-ordinated in all Iu signalling connections existing for the MS.

Upon reception of the UTRAN Mobility Information message the MS may start sending uplink user data to the target SRNC. When the MS has reconfigured itself, it sends the RAN Mobility Information Confirm message to the target SRNC. This indicates that the MS is also ready to receive downlink data from the target SRNC.

For all **point-to-point** RABs, the target RNC should:

start uplink reception of data and start transmission of uplink GTP-PDUs towards the new SGSN;

start processing the already buffered and the arriving downlink GTP-PDUs and start downlink transmission towards the MS.

**For all MBMS RABs**, the target RNC should:

start processing the arriving downlink GTP-PDUs and start downlink transmission towards the MS.



11) Upon receipt of the Relocation Detect message, the CN may switch the user plane from source RNC to target SRNC. If the SRNS Relocation is an inter SGSN SRNS relocation, the new SGSN sends Update PDP Context Request messages (new SGSN Address, SGSN Tunnel Endpoint Identifier, QoS Negotiated) to the GGSNs concerned. The GGSNs update their PDP context fields and return an Update PDP Context Response (GGSN Tunnel Endpoint Identifier).

12) When the target SRNC receives the UTRAN Mobility Information Confirm message, i.e. the new SRNC—ID + S-RNTI are successfully exchanged with the MS by the radio protocols, the target SRNC shall initiate the Relocation Complete procedure by sending the Relocation Complete message to the new SGSN. The purpose of the Relocation Complete procedure is to indicate by the target SRNC the completion of the relocation of the SRNS to the CN.

13) Upon receiving the Relocation Complete message or if it is an inter-SGSN SRNS relocation; the Forward Relocation Complete message, the old SGSN sends an Iu Release Command message to the source RNC. When the RNC data-forwarding timer has expired the source RNC responds with an Iu Release Complete.

After the MS has finished the RNTI reallocation procedure and if the new Routeing Area Identification is different from the old one, the MS initiates the Routeing Area Update procedure.

## 7.5.2 Broadcast architecture

The support of Broadcast mode service relies on the following principle:

- Long term service announcement allow the UE to be aware of Broadcast services
- Broadcast service activation is always initiated by the BM-SC server

Broadcast service can be provided in a phased approach:

- A first phase explained in 7.5.2.1 uses a direct interface between BM-SC and RNC.
- A second phase explained in 7.5.2.2 uses MBMS PDP Contexts concepts.

### 7.5.2.1 Broadcast service with direct interface between BM-SC and RNC

#### 7.5.2.1.1 MBMS Broadcast service activation

This scenario requires fewer changes in the UMTS network as it is based on re-use of the CBS principle that impacts the RNC and the BM-SC network elements without impacting GGSN and SGSN. This scenario allows more rapid deployment of the MBMS Broadcast service.

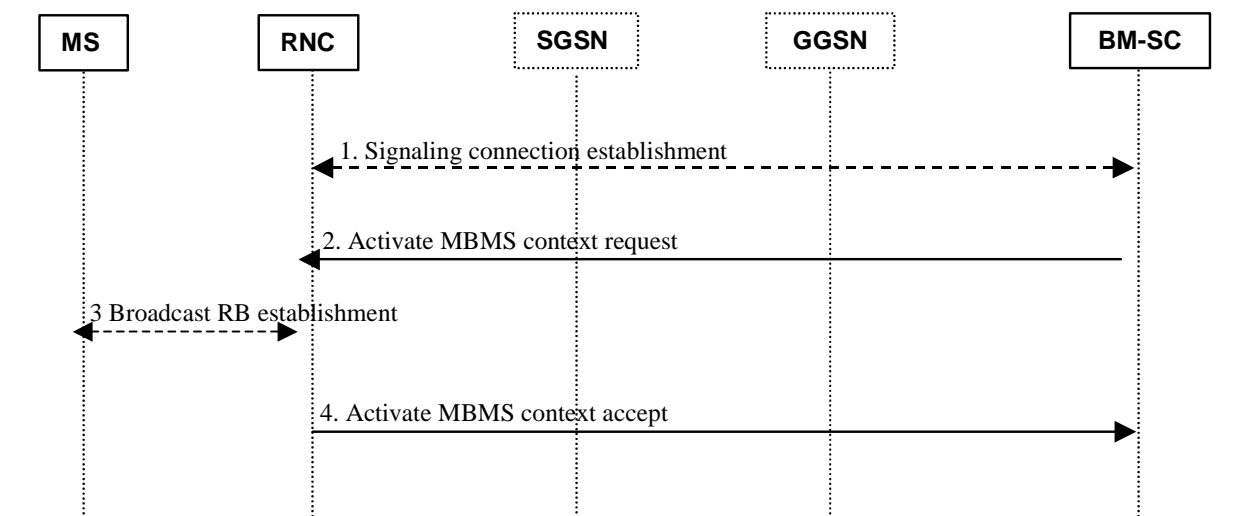
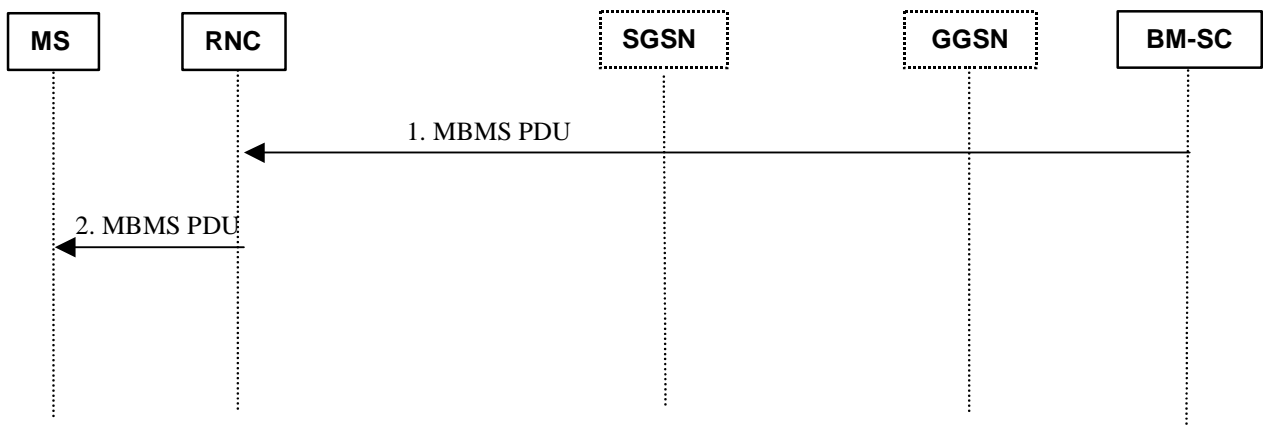

Figure 62: Broadcast service with interface between BM-SC and RNC

- [1. A signalling connection is established between the BM-SC and the RNC\(s\).](#)
- [2. BM-SC requests the RNC to establish RBs for a MBMS broadcast service. User Plane is established between the BM-SC and the RNC\(s\).](#)
- [3. Broadcast RBs are established. It is FFS in UTRAN group.](#)
- [4. The RNC acknowledges the MBMS broadcast activation.](#)

### [7.5.2.1.2 MBMS Broadcast Data Transfer](#)



**Figure 63: Broadcast service data transfer**

- [1. BM-SC sends MBMS data to the RNC](#)
- [2. The RNC forwards data on appropriate radio bearers. The RNC can send a MBMS data notification.](#)

### [7.5.2.2 Broadcast service with MBMS PDP Contexts in the CN](#)

#### [7.5.2.2.1 MBMS Broadcast service activation](#)

[This scenario uses MBMS PDP Context concepts. It involves all UMTS network elements: RNC, SGSN and GGSN.](#)

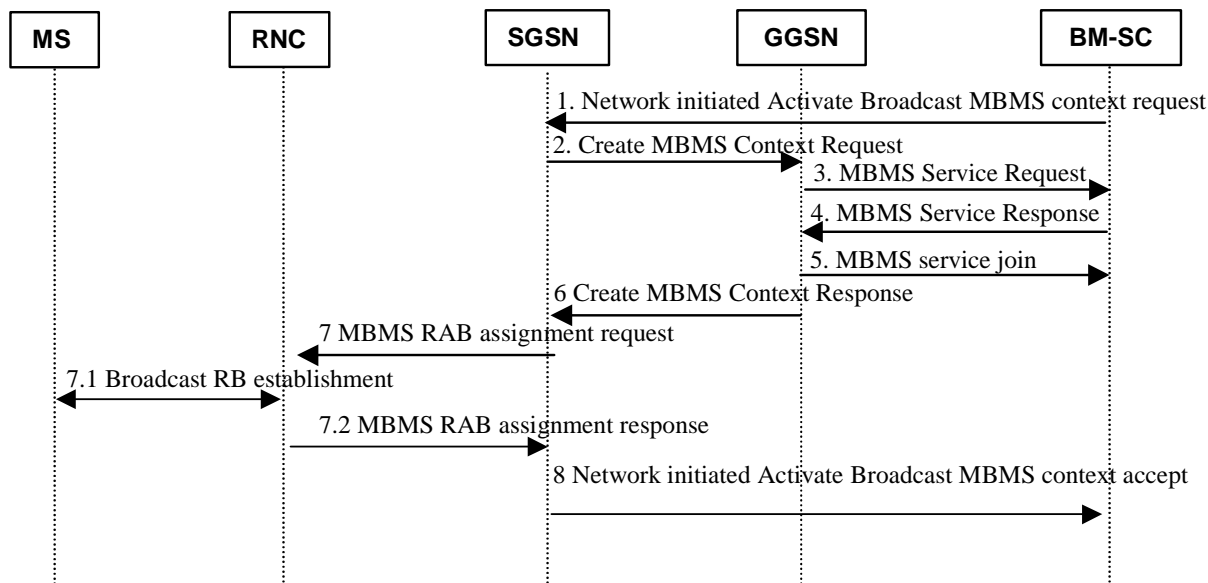

**Figure 64: Broadcast service with MBMS Contexts activation**

1. BM-SC request MBMS broadcast PDP Context activation to the SGSN(s). This may be based on existing Network Requested PDP context activation messages (FFS).
2. SGSN sends Create MBMS context request to a GGSN to request the creation of a MBMS context and establishment of GTP tunnel between SGSN and GGSN.
3. GGSN sends a MBMS Service Request to BM-SC to request MBMS service parameters like e.g. QoS and MBMS service area. Whether this could be optimized so that MBMS service parameters are provided in the Network initiated service activation is FFS.
4. BM-SC acknowledges this request by sending a MBMS Service Response, indicating the MBMS service QoS and MBMS service area.
5. GGSN sends a MBMS service join message to BM-SC, in order to join the MBMS session provided by BM-SC. This message is sent only once per GGSN and may be based on existing IETF multicast protocols, like MLD, IGMP, PIM, etc.
6. GGSN sends Create MBMS context response for confirmation of the establishment of GTP tunnel to SGSN. MBMS service parameters, e.g. MBMS service area and QoS, are provided.
7. SGSN activates the broadcast RAB with the RNC it manages. SGSN signals the MBMS service area to the appropriate RNCs in the MBMS RAB assignment request.
8. The SGSN sends Activate MBMS context accept to BM-SC. It is FFS whether this is based on existing network Requested PDP Context procedure.

#### 7.5.2.2.2 MBMS Broadcast Data Transfer

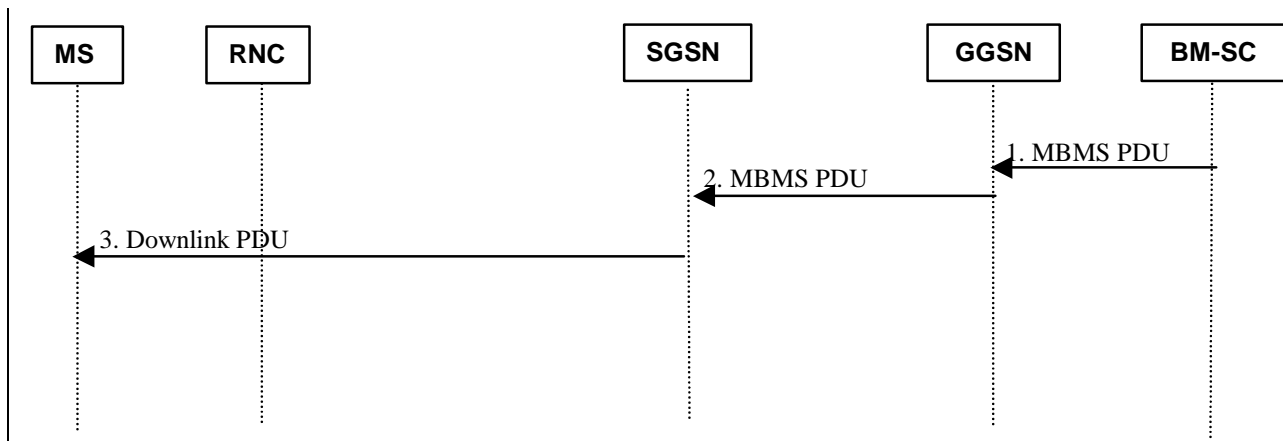

**Figure 65: MBMS broadcast service notification and data transfer setup**

1. BM-SC sends MBMS data to the GGSN

2. MBMS PDUs from BM-SC arriving in GGSN is forwarded on appropriate GTP tunnels towards SGSN(s).

3. The SGSN forwards MBMS PDUs to the RNCs. RNCs forwards data on appropriate radio bearers. The RNC can send a MBMS data notification.

## 7.6 Void

## 7.7 Option G

This architecture is designed to try to meet the demands of popular and dynamic point-to-multipoint services whilst considering efficient network resource usage and minimising the impact on existing procedures.

This option proposes a solution that ensures that data paths are only established to RNCs and SGSNs that have multicast users located in them. This option includes a signalling mechanism for users wishing to join and leave MBMS multicast groups.

A common MBMS bearer path establishment procedure is used to set up point-to-multipoint RABs for both broadcast and multicast MBMS services. However, a combined procedure to show simultaneous join and bearer establishment is also included. The MBMS Multicast service is distinguished by the use of an activation procedure based on IP Multicast protocols, which brings more alignment with the Internet model and hence faster service creation.

MBMS broadcast services are also supported.

Iu flex current working assumption is where the RNC is permitted to receive multiple streams. It then makes decision to take only one of the streams. Other solutions for the support of Iu Flex are not precluded

### 7.7.1 MBMS Multicast Service Activation

MBMS multicast activation is a procedure where the user signals the address of the multicast service he wishes to join.

In this architecture, a standard procedure first establishes a best effort PDP context activation on a per user basis. This procedure is used to identify the multicast service at a high level, e.g. APN pointing to a Sports service. In addition, this best effort PDP context is used by the UE to send an IGMP message to join MBMS multicast groups as and when

MBMS multicast services become available, e.g. football or tennis clips. This method of activation does not require repeated PDP context activation signalling every time individual services are activated.

In the case of IPv6, the appropriate equivalent protocol to IGMP (MLD) would be used.

Figure 66 shows a standard procedure for the establishment of a best-effort PDP context. The multicast group “join” command uses standard IETF message frame and no modifications to the Internet Protocol are proposed.

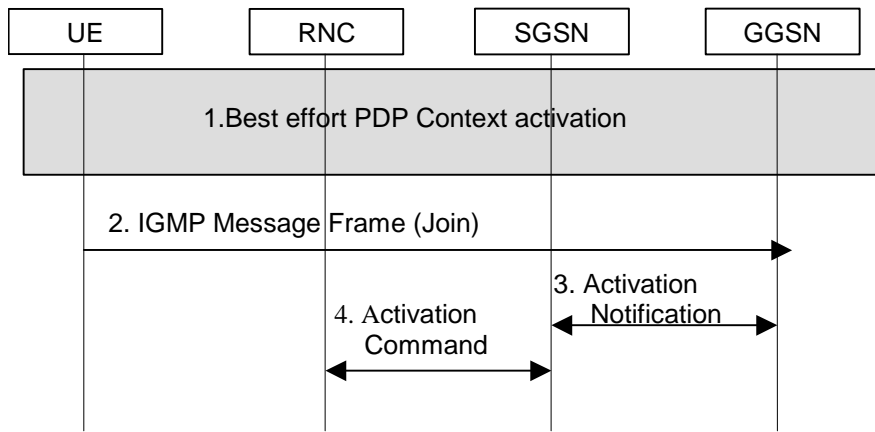

**Figure 66: Activation of an MBMS multicast service**

1. Step 1 is a standard procedure for best-effort PDP context activation signalling. The UE sends a user-specific best-effort PDP Context Activation request to the SGSN with a multicast APN. This step establishes a UE-specific MBMS context at APN level. I.e. providing service identity according to a specific GGSN/BM-SC.

SGSN performs normal service level subscription verification.

Note that the following message is only sent when users wish to join a group as and when services become available.

2. An IGMP frame is sent over the bearer path towards the GGSN. This message carries the IP multicast address which identifies the MBMS multicast service the user wishes to join. The GGSN picks up the join request and completes the MBMS Context for that UE. Additionally, the GGSN can verify the user’s subscription using RADIUS/Diameter.

3. The GGSN informs the SGSN about the user join to the multicast service using the GTP activation notification. The SGSN creates an MBMS context for the UE. The SGSN forms an association between the “MBMS data notification” and the MBMS PDP context

4. The SGSN informs the RNC about the user join to the multicast service. The RNC creates an MBMS specific context for the UE. When a user joins mid-stream and the multicast bearer already exist over Iu, the activation command carries the information about this stream to allow the RNC to link the user to this bearer. Note that this message is the RANAP RAB assignment message with appropriate IEs. The message name in the flow has been chosen for clarification of the purpose of the message.

### 7.7.2 MBMS Broadcast Service activation

The reception of MBMS Broadcast services is initiated by user selection of an MBMS broadcast channel identifier on the UE. Therefore there is no explicit activation signalling of MBMS broadcast services from the UE to the network since the network has no knowledge of the user. The MBMS broadcast service is “activated” in the network upon reception of MBMS broadcast data by the GGSN. The bearer path in the network is established in the same manner as the bearer path for MBMS multicast mode (see section below).

### 7.7.3 MBMS broadcast & multicast bearer path set-up

MBMS RABs are set up when data is available to the GGSN either from the BM-SC or 3<sup>rd</sup> party content source. MBMS data path set-up is described in figure 2. This procedure is common for both MBMS broadcast and MBMS multicast services however for MBMS multicast, notification is only sent to SGSNs where users are registered. Also there are differences across the air-interface between MBMS broadcast and MBMS multicast. These are not shown as they are outside the scope of SA2.

If Iu-flex is configured, then SGSNs are not necessarily defined by geographical area. This is important in the case of MBMS broadcast.

#### 7.7.3.1 MBMS Bearer path set-up with Iu-Flex

Iu-flex is handled and supported in line with sub-section 6.10.2.

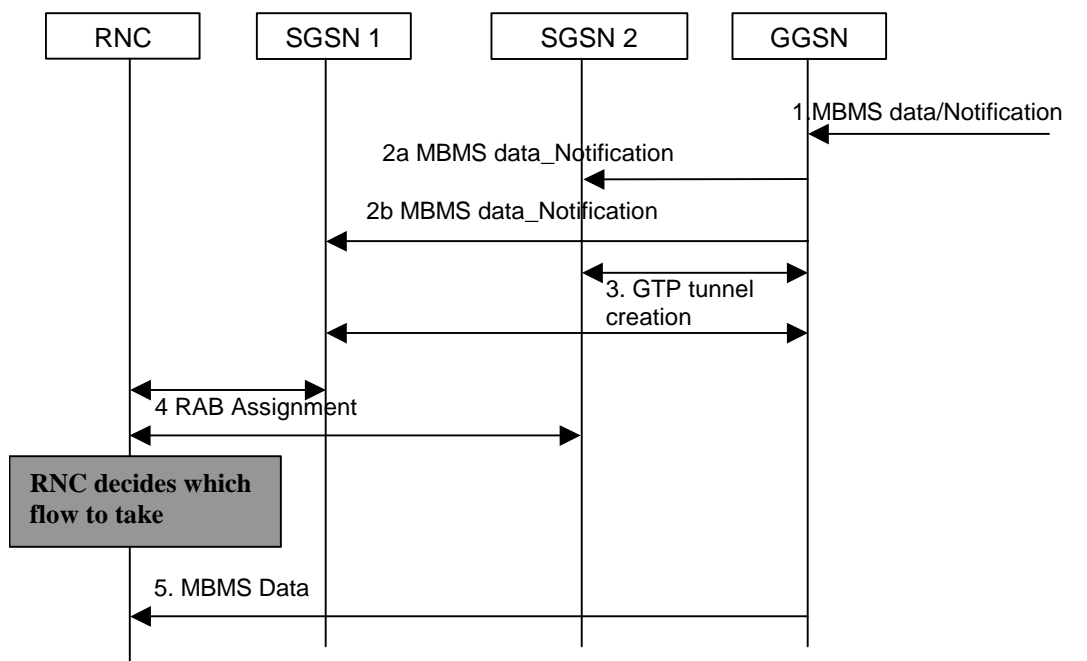

**Figure 67: MBMS Bearer Path set-up with Iu-Flex configured**

1. MBMS data or notification of data is sent from the data source, (BM-SC or 3<sup>rd</sup> party content provider) to the GGSN. In the case of MBMS broadcast mode, this could be scheduled broadcast data.
2. The GGSN sends a “MBMS Data Notification” to all SGSNs for MBMS broadcast or only to those SGSNs where MBMS multicast users are registered for MBMS multicast. This message would include the multicast service identity (TMGI) and QoS information, (see 7.7.10).
3. SGSN creates GTP tunnel to the GGSN
4. The SGSN also sets up RAB to the RNC. The RAB request is sent over a common control channel over Iu.. The RNC forms an association between user contexts and the MBMS RAB. The RNC picks one of the RAB flows for data to be sent over the air.
5. Multicast MBMS data is tunnelled down to the RNC from the GGSN.

### 7.7.3.2 MBMS Bearer path set-up when Iu-Flex is not configured

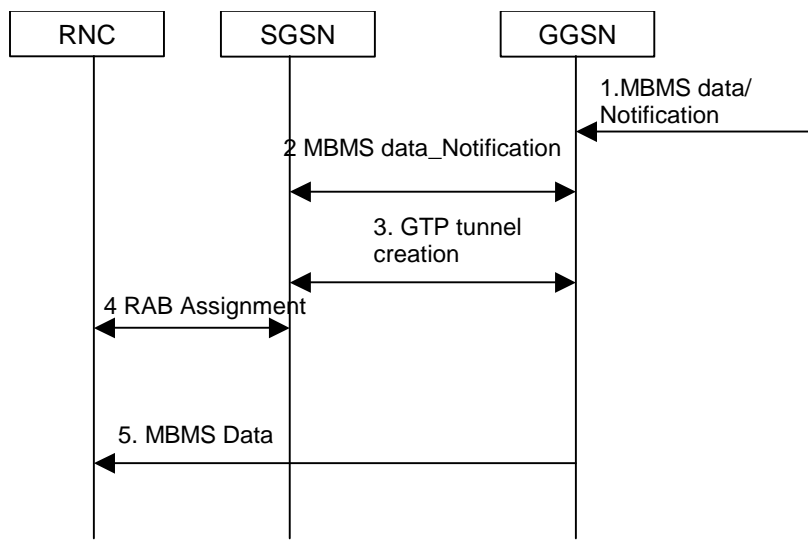

**Figure 68: MBMS Bearer Path set-up when Iu-Flex is not configured**

1. MBMS data or notification of data is sent from the data source, (BM-SC or 3<sup>rd</sup> party content provider) to the GGSN. In the case of MBMS broadcast mode, this could be scheduled broadcast data.
2. The GGSN sends a “MBMS Data Notification” to all SGSNs for MBMS broadcast or only to those SGSNs where MBMS multicast users are registered for MBMS multicast. This message would include the multicast service identity (TMGI) and QoS information, (see 7.7.10)
3. SGSN creates GTP tunnel to the GGSN
4. The SGSN also sets up RAB to the RNC. The RAB request is sent over a common control channel over Iu. The RNC forms an association between user contexts and the MBMS RAB.
5. Multicast MBMS data is tunnelled down to the RNC from the GGSN

### 7.7.3.3 Multicast Bearer path set-up with simultaneous join

Figure 43 shows a simultaneous multicast join and bearer path set up procedure.. This may be used where data is available immediately after the notification; for example where each video clip is in itself a session (i.e. each video clip would require a separate join command).

In this example Iu-Flex is not configured.

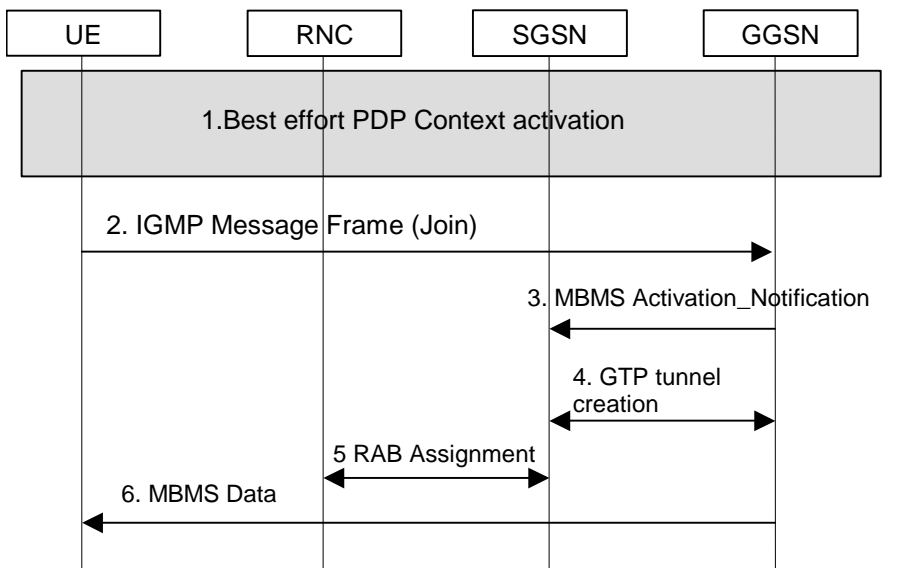

**Figure 69: Multicast bearer set-up simultaneous with user join**

1. The UE sends a user-specific best-effort PDP Context Activation request to the SGSN with a multicast APN. This step establishes a UE-specific MBMS context at APN level. I.e. providing service identity according to a specific GGSN/BM-SC.

SGSN performs normal service level subscription verification.

2. An IGMP frame is sent over the bearer path towards the GGSN. This message carries the IP multicast address which identifies the MBMS multicast service the user wishes to join. The GGSN picks up the join request and completes the MBMS Context for that UE. Additionally, the GGSN can verify the user’s subscription using RADIUS/Diameter.

3. The GGSN sends a “MBMS Activation Notification” to the SGSN where the MBMS multicast user is registered. This message would include the multicast service identity (TMGI) and QoS information (see 7.6.10). This notification message also indicates that data is available immediately.

4. The data availability indication to the SGSN triggers the creation of the GTP tunnel to the GGSN.

5. The SGSN sets up a RAB to the RNC. If in the case of MBMS multicast the RNC is already receiving data for the particular service, then it joins the user to the group. The RAB request is sent over a common MBMS control channel over Iu. The RNC forms an association between user contexts and the MBMS RAB.

6. Multicast MBMS data is tunnelled down to the RNC from the GGSN

### 7.7.4 Service Continuity and Mobility

In this architecture, the SGSN and RAN track multicast users using existing mobility management mechanisms but with small extensions for multicast users.

The following three scenarios are taken from TS23.060 where relocation procedures take into account Iur and user state. The full text from TS23.060 is used and the MBMS specific additions are highlighted in bold. No other changes are proposed to the procedures.



### 7.7.4.1 Serving RNS Relocation Procedures

The Serving SRNS Relocation procedure is illustrated in Figure 3. The sequence is valid for both intra-SGSN SRNS relocation and inter-SGSN SRNS relocation.

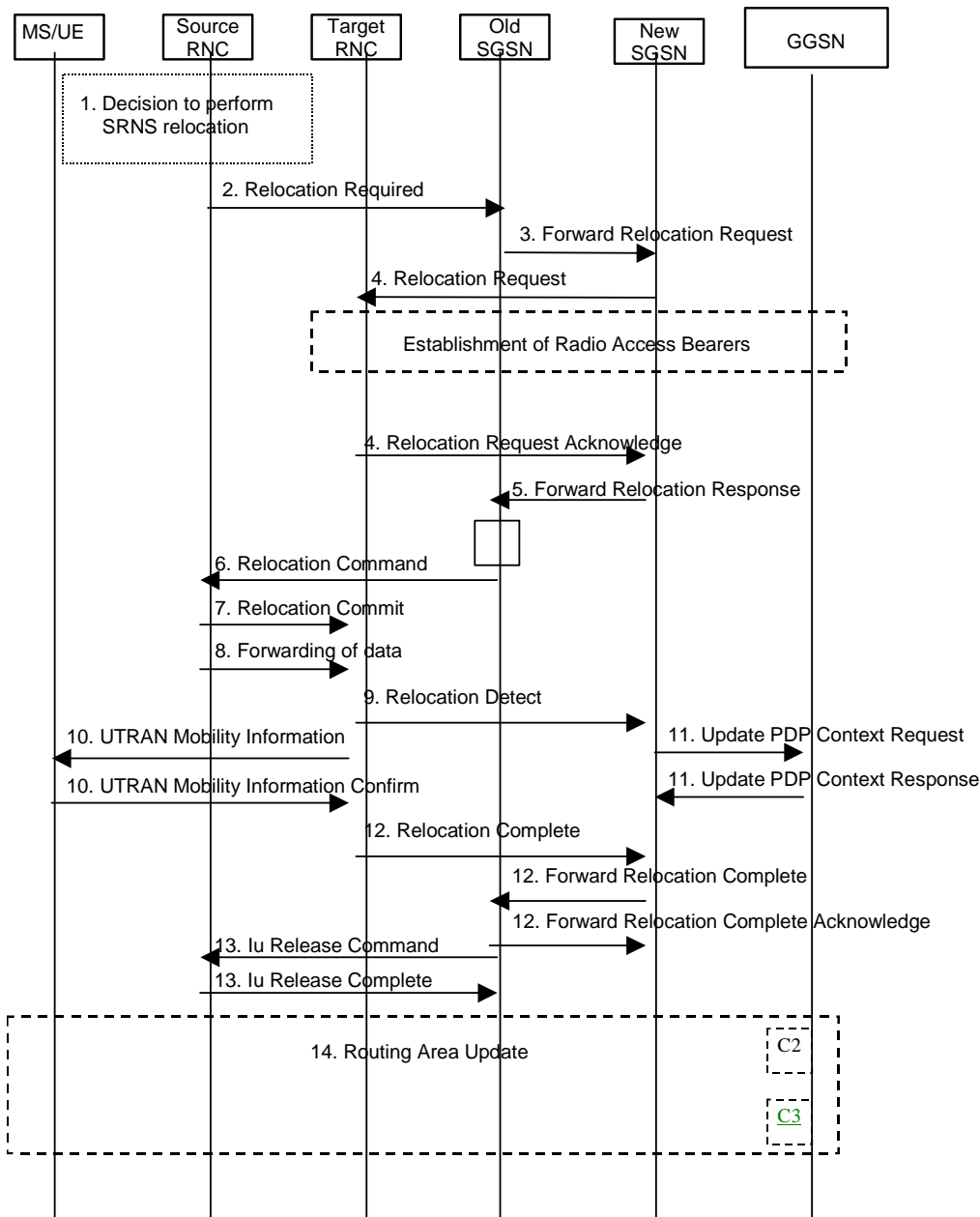

**Figure 70: Serving SRNS Relocation Procedure**

1) The source SRNC decides to perform/initiate SRNS relocation. At this point both uplink and downlink user data flows via the following tunnel(s): Radio Bearer between MS and source SRNC (data flows via the target RNC, which acts as a drift RNC); GTP-U tunnel(s) between source SRNC and old-SGSN; GTP-U tunnel(s) between old-SGSN and GGSN.

2) The source SRNC sends a Relocation Required message (Relocation Type, Cause, Source ID, Target ID, Source RNC to target RNC transparent container) to the old SGSN. The source SRNC shall set the Relocation Type to "UE not involved". The Source SRNC to Target RNC Transparent Container includes the necessary information

for Relocation co-ordination, security functionality and RRC protocol context information (including MS Capabilities).

3) The old SGSN determines from the Target ID if the SRNS Relocation is intra-SGSN SRNS relocation or inter-SGSN SRNS relocation. In case of inter-SGSN SRNS relocation, the old SGSN initiates the relocation resource allocation procedure by sending a Forward Relocation Request message (IMSI, Tunnel Endpoint Identifier Signalling, MM Context, PDP Context **MBMS PDP context**) Target Identification, UTRAN transparent container, RANAP Cause) to the new SGSN. PDP context contains GGSN Address for User Plane and Uplink TEID for Data (to this GGSN Address and Uplink TEID for Data, the old SGSN and the new SGSN send uplink packets). At the same time a timer is started on the MM and PDP contexts in the old SGSN (see the Routing Area Update procedure in subclause "Location Management Procedures (UMTS only)"). The Forward Relocation Request message is applicable only in the case of inter-SGSN SRNS relocation.

4) The new SGSN sends a Relocation Request message (Permanent NAS UE Identity, Cause, CN Domain Indicator, Source RNC to target RNC transparent container, RABs to be setup **including multicast MBMS RABs**) to the target RNC. Only the Iu Bearers of the RABs are setup between the target RNC and the new-SGSN as the existing Radio Bearers will be reallocated between the MS and the target RNC when the target RNC takes the role of the serving RNC. For each requested RAB, the RABs to be setup information elements shall contain information such as RAB ID, RAB parameters, Transport Layer Address, and Iu Transport Association. The RAB ID information element contains the NSAPI value, and the RAB parameters information element gives the QoS profile. The Transport Layer Address is the SGSN Address for user data, and the Iu Transport Association corresponds to the uplink Tunnel Endpoint Identifier Data. After all necessary resources for accepted RABs including the Iu user plane are successfully allocated; the target RNC shall send the Relocation Request Acknowledge message (RABs setup, RABs failed to setup) to the new SGSN. Each RAB to be setup is defined by a Transport Layer Address, which is the target RNC Address for user data, and an Iu Transport Association, which corresponds to the downlink Tunnel Endpoint Identifier for user data. The target RNC may be set-up to simultaneously receive for each RAB downlink user packets both from the source SRNC and from the new SGSN.

After the new SGSN receives the Relocation Request Acknowledge message, the GTP-U tunnels are established between the target RNC and the new-SGSN.

5) When resources for the transmission of user data between the target RNC and the new SGSN have been allocated and the new SGSN is ready for relocation of SRNS, the Forward Relocation Response message (Cause, RANAP Cause, and RAB Setup Information) is sent from the new SGSN to old SGSN. This message indicates that the target RNC is ready to receive from source SRNC the forwarded downlink PDUs, i.e. the relocation resource allocation procedure is terminated successfully. RANAP Cause is information from the target RNC to be forwarded to the source SRNC. The RAB Setup Information, one information element for each RAB, contains the RNC Tunnel Endpoint Identifier and the RNC IP address for data forwarding from the source SRNC to the target RNC. If the target RNC or the new SGSN failed to allocate resources, the RAB Setup Information element contains only NSAPI indicating that the source SRNC shall release the resources associated with the NSAPI. The Forward Relocation Response message is applicable only in case of inter-SGSN SRNS relocation.

6) The old SGSN continues the relocation of SRNS by sending a Relocation Command message (RABs to be released, and RABs subject to data forwarding) to the source SRNC. The old SGSN decides the RABs to be subject for data forwarding based on QoS, and those RABs shall be contained in RABs subject to data forwarding. For each RAB subject to data forwarding, the information element shall contain RAB ID, Transport Layer Address, and Iu Transport Association. These are the same Transport Layer Address and Iu Transport Association that the target RNC had sent to new SGSN in Relocation Request Acknowledge message, and these are used for forwarding of downlink N-PDU from source SRNC to target RNC. The source SRNC is now ready to forward downlink user data directly to the target RNC over the Iu interface. This forwarding is performed for downlink user data only.

7) Upon reception of the Relocation Command message from the PS domain, the source SRNC shall start the data-forwarding timer. Note: The order of steps, starting from step 7 onwards, does not necessarily reflect the order of events. For instance, source RNC may start data forwarding (step 7) and send Relocation Commit message (step 8) almost simultaneously except in the delivery order required case where step 7 triggers step 8. Target RNC may send Relocation Detect message (step 9) and UTRAN Mobility Information message (step 10) at the same time. Hence, target RNC may receive UTRAN Mobility Information Confirm message (step 10) while data forwarding (step 7) is still underway, and before the new SGSN receives Update PDP Context Response message (step 11).

When the source SRNC is ready, the source SRNC shall trigger the execution of relocation of SRNS by sending a Relocation Commit message (SRNS Contexts) to the target RNC over the Iur interface. The purpose of this procedure is to transfer SRNS contexts from the source RNC to the target RNC, and to move the SRNS role from the source RNC to the target RNC. SRNS contexts are sent for each concerned RAB and contain the sequence numbers of the GTP-U PDUs next to be transmitted in the uplink and downlink directions and the next PDCP sequence numbers that would have been used to send and receive data from the MS. For PDP context(s) using delivery order not required (QoS profile), the sequence numbers of the GTP-U PDUs next to be transmitted are not used by the target RNC. PDCP sequence numbers are only sent by the source RNC used when for radio bearers which used lossless SRNS relocation is configured for PDCP [57]. The use of lossless PDCP is selected by the RNC when the radio bearer is set up or reconfigured.

If delivery order is required (QoS profile), consecutive GTP-PDU sequence numbering shall be maintained throughout the lifetime of the PDP context(s). Therefore, during the entire SRNS relocation procedure for the PDP context(s) using delivery order required (QoS profile), the responsible GTP-U entities (RNCs and GGSN) shall assign consecutive GTP-PDU sequence numbers to user packets belonging to the same PDP context for uplink and downlink respectively

Before sending the Relocation Commit uplink and downlink data transfer in the source, SRNC shall be suspended for RABs, which require maintaining the delivery order.

- 8) The source RNC begins the forwarding of data for the RABs to be subject for data forwarding. The data forwarding at SRNS relocation shall be carried out through the Iu interface, meaning that the GTP-U PDUs, which are exchanged between the source RNC and the target RNC, are duplicated in the source RNC and routed at IP layer towards the target RNC. For each radio bearer which uses lossless PDCP the GTP-U PDUs corresponding to transmitted but not yet acknowledged PDCP PDUs are duplicated and routed at IP layer towards the target RNC together with their related downlink PDCP sequence numbers.
- 9) The target RNC shall send a Relocation Detect message to the new SGSN when the relocation execution trigger is received. For SRNS relocation type "UE not involved", the relocation execution trigger is the reception of the Relocation Commit message from the Iur interface. When the Relocation Detect message is sent, the target RNC shall start SRNC operation.
- 10) The target SRNC sends a UTRAN Mobility Information message. This message contains UE information elements and CN information elements. The UE information elements include among others new SRNC identity and S-RNTI. The CN information elements contain among others Location Area Identification and Routing Area Identification. The procedure shall be co-ordinated in all Iu signalling connections existing for the MS.

The target SRNC establishes and/or restarts the RLC, and exchanges the PDCP sequence numbers (PDCP-SNU, PDCP-SND) between the target SRNC and the MS. PDCP-SND is the PDCP sequence number for the next expected in-sequence downlink packet to be received in the MS per radio bearer, which uses lossless PDCP in the source RNC. PDCP-SND confirms all mobile-terminated packets successfully transferred before the SRNC relocation. If PDCP-SND confirms reception of packets that were forwarded from the source SRNC, the target SRNC shall discard these packets. PDCP-SNU is the PDCP sequence number for the next expected in-sequence uplink packet to be received in the RNC per radio bearer, which used lossless PDCP in the source RNC. PDCP-SNU confirms all mobile originated packets successfully transferred before the SRNC relocation. If PDCP-SNU confirms reception of packets that were received in the source SRNC, the MS shall discard these packets.

Upon reception of the UTRAN Mobility Information message the MS may start sending uplink user data to the target SRNC. When the MS has reconfigured itself, it sends the UTRAN Mobility Information Confirm message to the target SRNC. This indicates that the MS is also ready to receive downlink data from the target SRNC.

If the new SGSN has already received the Update PDP Context Response message from the GGSN, it shall forward the uplink user data to GGSN over this new GTP-U tunnel. Otherwise, the new SGSN shall forward the uplink user data to that GGSN IP address and TEID(s), which the new SGSN had received earlier by the Forward Relocation Request message.

- 11) Upon receipt of the Relocation Detect message, the CN may switch the user plane from source RNC to target SRNC. If the SRNS Relocation is an inter SGSN SRNS relocation, the new SGSN sends Update PDP Context Request messages (new SGSN Address, SGSN Tunnel Endpoint Identifier, QoS Negotiated) to the GGSNs concerned. The GGSNs update their PDP context fields and return an Update PDP Context Response (GGSN Tunnel Endpoint Identifier).
- 12) When the target SRNC receives the UTRAN Mobility Information Confirm message, i.e. the new SRNC-ID + S-RNTI are successfully exchanged with the MS by the radio protocols, the target SRNC shall initiate the Relocation Complete procedure by sending the Relocation Complete message to the new SGSN. The purpose of the Relocation Complete procedure is to indicate by the target SRNC the completion of the relocation of the SRNS to the CN. If the user plane has not been switched at Relocation Detect and upon reception of Relocation Complete, the CN shall switch the user plane from source RNC to target SRNC. If the SRNS Relocation is an inter-SGSN SRNS relocation, the new SGSN shall signal to the old SGSN the completion of the SRNS relocation procedure by sending a Forward Relocation Complete message.
- 13) Upon receiving the Relocation Complete message or if it is an inter-SGSN SRNS relocation; the Forward Relocation Complete message, the old SGSN sends an Iu Release Command message to the source RNC. When the RNC data-forwarding timer has expired the source RNC responds with an Iu Release Complete.
- 14) After the MS has finished the RNTI reallocation procedure and if the new Routing Area Identification is different from the old one, the MS initiates the Routing Area Update procedure. See subclause "Location Management Procedures (UMTS only)". Note that it is only a subset of the RA update procedure that is performed, since the MS is in PMM-CONNECTED mode.

CAMEL procedure calls shall be performed, see referenced procedures in 3G TS 23.078:

C1) CAMEL\_GPRS\_PDP\_Context\_Disconnection and CAMEL\_GPRS\_Detach.

They are called in the following order:

- The CAMEL\_GPRS\_PDP\_Context\_Disconnection procedure is called several times: once per PDP context. The procedure returns as result "Continue".
- Then the CAMEL\_GPRS\_Detach procedure is called once. The procedure returns as result ""Continue"".

C2) CAMEL\_GPRS\_Routing\_Area\_Update\_Session.

The procedure returns as result "Continue".

C3) CAMEL\_GPRS\_Routing\_Area\_Update\_Context.

This procedure is called several times: once per PDP context. It returns as result "Continue".

For C2 and C3: refer to Routing Area Update procedure description for detailed message flow.

### 7.7.4.2 Combined Hard Handover and SRNS Relocation Procedure

This procedure is only performed for an MS/UE in PMM-CONNECTED state in case the Iur interface is not available.

The Combined Hard Handover and SRNS Relocation procedure for the PS domain is illustrated in Figure 4. The sequence is valid for both intra-SGSN SRNS relocation and inter-SGSN SRNS relocation.

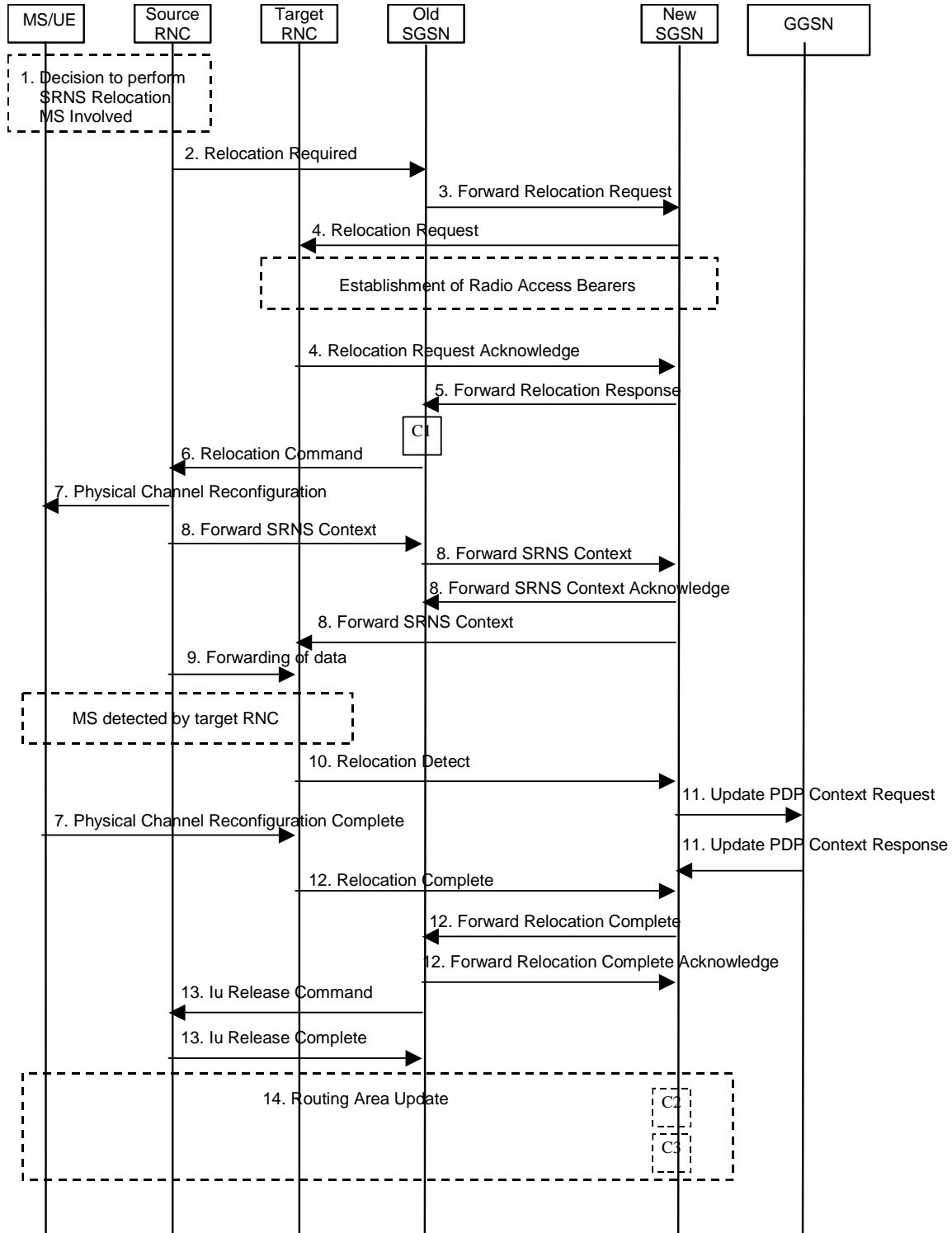

**Figure 71: Combined Hard Handover and SRNS Relocation Procedure**

e

- 1) Based on measurement results and knowledge of the UTRAN topology, the source SRNC decides to initiate a combined hard handover and SRNS relocation. At this point both uplink and downlink user data flows via the following tunnel(s): Radio Bearer between the MS and the source SRNC (no drift RNC available); GTP-U tunnel(s) between the source SRNC and the old SGSN; GTP-U tunnel(s) between the old SGSN and the GGSN.
- 2) The source SRNC sends a Relocation Required message (Relocation Type, Cause, Source ID, Target ID, Source RNC To Target RNC Transparent Container) to the old SGSN. The source SRNC shall set Relocation Type to "UE Involved". Source RNC To Target RNC Transparent Container includes the necessary information for relocation co-ordination, security functionality and RRC protocol context information (including MS Capabilities).
- 3) The old SGSN determines from the Target ID if the SRNS relocation is intra-SGSN SRNS relocation or inter-SGSN SRNS relocation. In case of inter-SGSN SRNS relocation the old SGSN initiates the relocation resource allocation procedure by sending a Forward Relocation Request message (IMSI, Tunnel Endpoint Identifier Signalling, MM Context, PDP Context **MBMS PDP context**), Target Identification, UTRAN Transparent Container, RANAP Cause) to the new SGSN. PDP context contains GGSN Address for User Plane and Uplink TEID for Data (to this GGSN Address and Uplink TEID for Data, the old SGSN and the new SGSN send uplink packets). At the same time a timer is started on the MM and PDP contexts in the old SGSN (see Routeing Area Update procedure in subclause "Location Management Procedures (UMTS only)"). The Forward Relocation Request message is applicable only in case of inter-SGSN SRNS relocation
- 4) The new SGSN sends a Relocation Request message (Permanent NAS UE Identity, Cause, CN Domain Indicator, Source RNC To Target RNC Transparent Container, RABs To Be Setup **including MBMS multicast RABs**) to the target RNC. For each requested RAB, RABs To Be Setup shall contain information such as RAB ID, RAB parameters, Transport Layer Address, and Iu Transport Association. The RAB ID information element contains the NSAPI value, and the RAB parameters information element gives the QoS profile. The Transport Layer Address is the SGSN Address for user data, and the Iu Transport Association corresponds to the uplink Tunnel Endpoint Identifier Data.

After all the necessary resources for accepted RABs including the Iu user plane are successfully allocated, the target RNC shall send the Relocation Request Acknowledge message (Target RNC To Source RNC Transparent Container, RABs Setup, RABs Failed To Setup) to the new SGSN. Each RAB to be setup is defined by a Transport Layer Address, which is the target RNC Address for user data, and the Iu Transport Association, which corresponds to the down-link Tunnel Endpoint Identifier for user data. The transparent container contains all radio-related information that the MS needs for the handover, i.e., a complete RRC message (e.g., Physical Channel Reconfiguration) to be sent transparently via CN and source SRNC to the MS. The target RNC may for each RAB to be set up receive simultaneously downlink user packets both from the source SRNC and from the new SGSN.

After the new SGSN receives the Relocation Request Acknowledge message, the GTP-U tunnel(s) are established between the target RNC and the new SGSN. However at this point, the target RNC has not yet established the Radio Bearer(s) with the MS yet.

- 5) When resources for the transmission of user data between target RNC and new SGSN have been allocated and the new SGSN is ready for relocation of SRNS, the Forward Relocation Response (Cause, UTRAN Transparent Container, RANAP Cause, Target RNC Information) message is sent from the new SGSN to the old SGSN. This message indicates that the target RNC is ready to receive from source SRNC the forwarded downlink PDUs, i.e., the relocation resource allocation procedure is terminated successfully. UTRAN transparent container and RANAP Cause are information from the target RNC to be forwarded to the source SRNC. The Target RNC Information, one information element for each RAB to be set up, contains the RNC Tunnel Endpoint Identifier and RNC IP address for data forwarding from the source SRNC to the target RNC. The Forward Relocation Response message is applicable only in case of inter-SGSN SRNS relocation.
- 6) The old SGSN continues the relocation of SRNS by sending a Relocation Command message (Target RNC To Source RNC Transparent Container, RABs To Be Released, RABs Subject To Data Forwarding) to the source SRNC. The old SGSN decides the RABs to be subject for data forwarding based on QoS, and those RABs shall be contained in RABs subject to data forwarding. For each RAB subject to data forwarding, the information element shall contain RAB ID, Transport Layer Address, and Iu Transport Association. These are the same Transport Layer Address and Iu Transport

Association that the target RNC had sent to new SGSN in Relocation Request Acknowledge message, and these are used for forwarding of downlink N-PDU from the source SRNC to the target RNC. The source SRNC is now ready to forward downlink user data directly to the target RNC over the Iu interface. This forwarding is performed for downlink user data only.

- 7) Upon reception of the Relocation Command message from the PS domain, the source RNC shall start the data-forwarding timer.

Note: The order of steps, starting from step 7 onwards, does not necessarily reflect the order of events. For instance, source RNC may send RRC message to MS (step 7), Forward SRNS Context message to the old SGSN (step 8) and starts data forwarding (step 9) almost simultaneously.

When the source SRNC is ready, the source RNC shall trigger the execution of relocation of SRNS by sending to the MS the RRC message provided in the Target RNC to source RNC transparent container, e.g., a Physical Channel Reconfiguration (UE Information Elements, CN Information Elements) message. UE Information Elements include among others new SRNC identity and S-RNTI. CN Information Elements contain among others Location Area Identification and Routing Area Identification.

Before the RRC message is sent (e.g. Physical Channel Reconfiguration) uplink and downlink data transfer in the source RNC shall be suspended for RABs which require to maintain the delivery order.

When the MS has reconfigured it self, it sends e.g., a Physical Channel Reconfiguration Complete message to the target SRNC. If the Forward SRNS Context message with the sequence numbers is received, the exchange of packets with the MS may start. If this message is not yet received, the target RNC may start the packet transfer for all RABs, which do not require maintaining the delivery order.

- 8) The source SRNC continues the execution of relocation of SRNS by sending a Forward SRNS Context (RAB Contexts) message to the target RNC via the old and the new SGSN, which is acknowledged by a Forward SRNS Context Acknowledge message. The purpose of this procedure is to transfer SRNS contexts from the source RNC to the target RNC, and to move the SRNS role from the source RNC to the target RNC. SRNS contexts are sent for each concerned RAB and contain the sequence numbers of the GTP PDUs next to be transmitted in the uplink and downlink directions and the next PDCP sequence numbers that would have been used to send and receive data from the MS. PDCP sequence numbers are sent by the source RNC for the radio bearers which used lossless PDCP [57]. The use of lossless PDCP is selected by the RNC when the radio bearer is set up or reconfigured. For PDP context(s) using delivery order not required (QoS profile), the sequence numbers of the GTP-PDUs next to be transmitted are not used by the target RNC.

If delivery order is required (QoS profile), consecutive GTP-PDU sequence numbering shall be maintained throughout the lifetime of the PDP context(s). Therefore, during the entire SRNS relocation procedure for the PDP context(s) using delivery order required (QoS profile), the responsible GTP-U entities (RNCs and GGSN) shall assign consecutive GTP-PDU sequence numbers to user packets belonging to the same PDP context for uplink and downlink, respectively.

The target RNC establishes and/or restarts the RLC and exchanges the PDCP sequence numbers (PDCP-SNU, PDCP-SND) between the target RNC and the MS. PDCP-SND is the PDCP sequence number for the next expected in-sequence downlink packet to be received in the MS per radio bearer, which used lossless PDCP in the source RNC. PDCP-SND confirms all mobile terminated packets successfully transferred before the SRNC relocation. If PDCP-SND confirms reception of packets that were forwarded from the source SRNC, then the target RNC shall discard these packets. PDCP-SNU is the PDCP sequence number for the next expected in-sequence uplink packet to be received in the RNC per radio bearer, which used lossless PDCP in the source RNC. PDCP-SNU confirms all mobile originated packets successfully transferred before the SRNC relocation. If PDCP-SNU confirms reception of packets that were received in the source RNC, the MS shall discard these packets.

- 9) The source RNC begins the forwarding of data for the RABs to be subject for data forwarding. The data forwarding at SRNS relocation shall be carried out through the Iu interface, meaning that the data exchanged between the source RNC and the target RNC are duplicated in the source RNC and routed at the IP layer towards the target RNC. For each radio bearer using lossless PDCP, the GTP-PDUs corresponding to transmitted but not yet acknowledged PDCP-PDUs are duplicated and routed at IP layer towards the target RNC together with the corresponding downlink PDCP sequence numbers.

- 10) The target RNC shall send a Relocation Detect message to the new SGSN when the relocation execution trigger is received. For SRNS relocation type "UE Involved", the relocation execution trigger may be received from the



Uu interface; i.e., when target RNC detects the MS on the lower layers. When the Relocation Detect message is sent, the target RNC shall start SRNC operation.

11) Upon reception of the Relocation Detect message, the CN may switch the user plane from the source RNC to the target SRNC. If the SRNS relocation is an inter-SGSN SRNS relocation, the new SGSN sends an Update PDP Context Request (New SGSN Address, SGSN Tunnel Endpoint Identifier, QoS Negotiated) message to the GGSNs concerned. The GGSNs update their PDP context fields and return an Update PDP Context Response (GGSN Tunnel Endpoint Identifier) message.

12) When the target SRNC receives the Physical Channel Reconfiguration Complete message or the Radio Bearer Release Complete message, i.e. the new SRNC-ID + S-RNTI are successfully exchanged with the MS by the radio protocols, the target SRNC shall initiate a Relocation Complete procedure by sending the Relocation Complete message to the new SGSN. The purpose of the Relocation Complete procedure is to indicate by the target SRNC the completion of the relocation of the SRNS to the CN. If the user plane has not been switched at Relocation Detect, the CN shall upon reception of Relocation Complete switch the user plane from source RNC to target SRNC. If the SRNS Relocation is an inter-SGSN SRNS relocation, the new SGSN signals to the old SGSN the completion of the SRNS relocation procedure by sending a Forward Relocation Complete message.

13) Upon receiving the Relocation Complete message or if it is an inter-SGSN SRNS relocation, the Forward Relocation Complete message, the old SGSN sends an Iu Release Command message to the source RNC. When the RNC data-forwarding timer has expired, the source RNC responds with an Iu Release Complete message.

14) After the MS has finished the reconfiguration procedure and if the new Routeing Area Identification is different from the old one, the MS initiates the Routeing Area Update procedure. See subclause "Location Management Procedures (UMTS only)". Note that it is only a subset of the RA update procedure that is performed, since the MS is in PMM-CONNECTED state.

CAMEL procedure calls shall be performed, see referenced procedures in 3G TS 23.078:

C1) CAMEL GPRS PDP Context Disconnection and CAMEL GPRS Detach

They are called in the following order:

- The CAMEL GPRS PDP Context Disconnection procedure is called several times: once per PDP context. The procedure returns as result "Continue".
- Then the CAMEL GPRS Detach procedure is called once. The procedure returns as result "Continue".

C2) CAMEL GPRS Routeing Area Update Session.

In figure above, the procedure returns as result "Continue".

C3) CAMEL GPRS Routeing Area Update Context.

This procedure is called several times: once per PDP context. It returns as result "Continue".

For C2 and C3: refer to Routing Area Update procedure description for detailed message flow.

### 7.7.4.3 Combined Cell / URA Update and SRNS Relocation Procedure

This procedure is only performed for an MS/UE in PMM-CONNECTED state, where the Iur interface carries control signalling but no user data.

The Combined Cell / URA Update and SRNS Relocation procedure is used to move the UTRAN to CN connection point at the UTRAN side from the source SRNC to the target RNC, while performing a cell re-selection in the UTRAN. In the procedure, the Iu links are relocated. If the target RNC is connected to the same SGSN as the source SRNC, an Intra-SGSN SRNS Relocation procedure is performed. If the routeing area is changed, this procedure is followed by an Intra-SGSN Routeing Area Update procedure. The SGSN detects that it is an intra-SGSN routeing area update by noticing that it also handles the old RA. In this case, the SGSN has the necessary information about the MS and there is no need to inform the HLR about the new MS location.

Before the Combined Cell / URA Update and SRNS Relocation and the Routeing Area Update, the MS is registered in the old SGSN. The source RNC is acting as serving RNC.



After the Combined Cell / URA Update and SRNS Relocation and the Routing Area Update, the MS is registered in the new SGSN. The MS is in state PMM-CONNECTED towards the new SGSN, and the target RNC is acting as serving RNC.

The Combined Cell / URA Update and SRNS Relocation procedure for the PS domain is illustrated in Figure 72. The sequence is valid for both intra-SGSN SRNS relocation and inter-SGSN SRNS relocation.

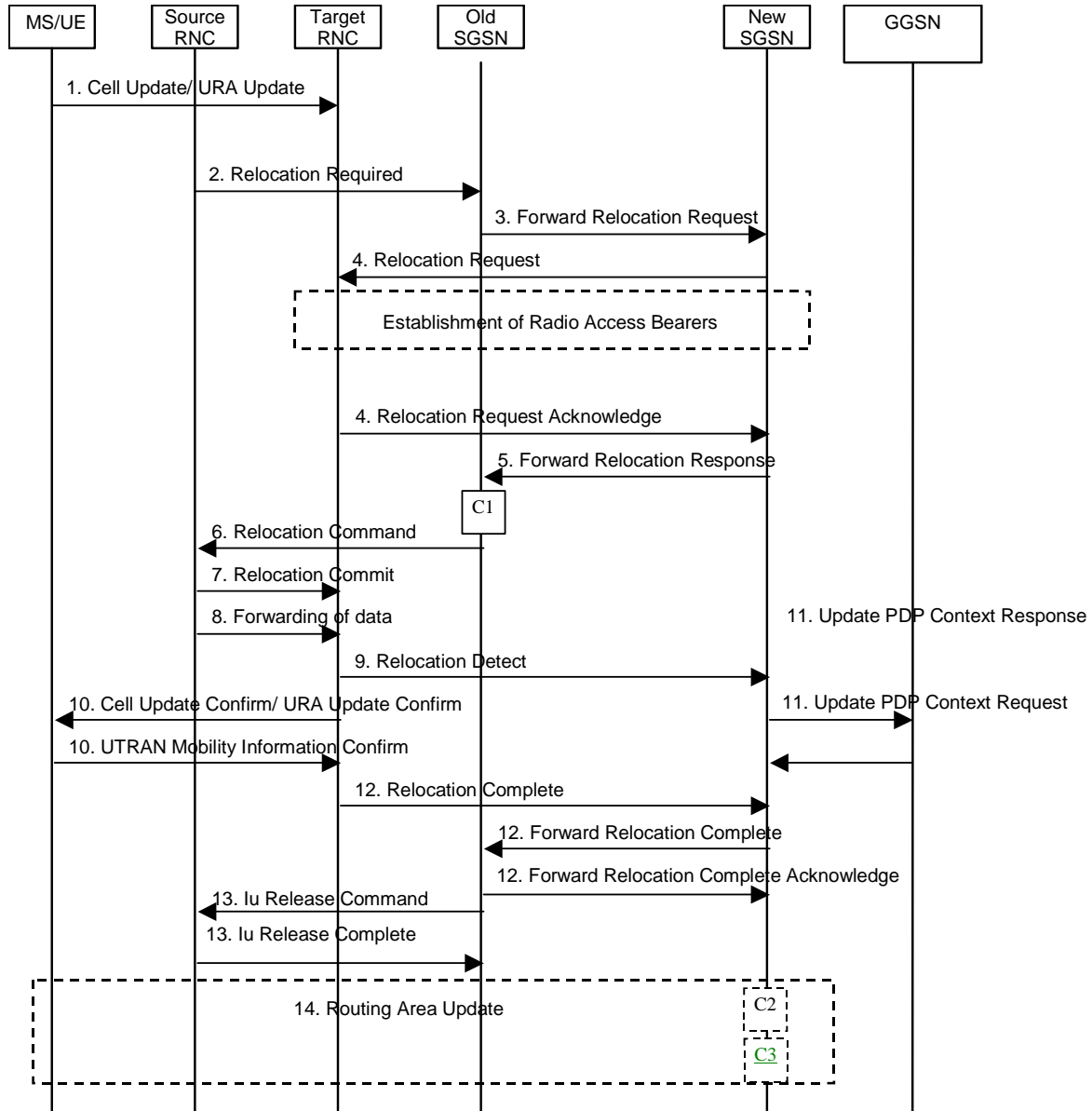

**Figure 72: Combined Cell / URA Update and SRNS Relocation Procedure**

- 1) The MS sends a Cell Update / URA Update message to the source SRNC (if the cell is located under another RNC the message is routed via the DRNC to SRNC over the Iur). The source SRNC decides whether or not to perform a combined cell / URA update and SRNS relocation towards the target RNC. The rest of this subclause describes the case where a combined cell / URA update and SRNS relocation applies. In this case no radio bearer is established between the source SRNC and the UE. Nonetheless the following tunnel(s) are established: GTP-U tunnel(s) between source SRNC and old-SGSN; GTP-U tunnel(s) between old-SGSN and GGSN.
- 2) The source SRNC sends a Relocation Required message (Relocation Type, Cause, Source ID, Target ID, Source RNC to Target RNC Transparent Container) to the old SGSN. The source SRNC shall set Relocation Type to "UE not involved". Source RNC to Target RNC Transparent Container includes the necessary information for

Relocation co-ordination, security functionality, and RRC protocol context information (including MS Capabilities).

- 3) The old SGSN determines from the Target ID if the SRNS Relocation is intra-SGSN SRNS relocation or inter-SGSN SRNS relocation. In the case of inter-SGSN SRNS relocation the old SGSN initiates the relocation resource allocation procedure by sending a Forward Relocation Request (IMSI, Tunnel Endpoint Identifier Signalling, MM Context, PDP Context **including MBMS PDP context**), Target Identification, UTRAN Transparent Container, RANAP Cause) message to the new SGSN. PDP context contains GGSN Address for User Plane and Uplink TEID for Data (to this GGSN Address and Uplink TEID for Data, the old SGSN and the new SGSN send uplink packets). At the same time a timer is started on the MM and PDP contexts in the old SGSN, see Routing Area Update procedure in subclause "Location Management Procedures (UMTS only)". The Forward Relocation Request message is applicable only in case of inter-SGSN SRNS relocation.
- 4) The new SGSN sends a Relocation Request message (Permanent NAS UE Identity, Cause, CN Domain Indicator, Source RNC to Target RNC Transparent Container, RABs To Be Setup **including MBMS multicast RABs**) to the target RNC. For each requested RAB, RABs To Be Setup shall contain information such as RAB ID, RAB parameters, Transport Layer Address, and Iu Transport Association. The RAB ID information element contains the NSAPI value, and the RAB parameters information element gives the QoS profile. The Transport Layer Address is the SGSN Address for user data, and the Iu Transport Association corresponds to the uplink Tunnel Endpoint Identifier Data.

After successful allocation of all necessary resources for accepted RABs including the Iu user plane, the target RNC shall send the Relocation Request Acknowledge message (RABs setup, RABs failed to setup) to the new SGSN. Each RAB to be setup is defined by a Transport Layer Address, which is the target RNC Address for user data, and an Iu Transport Association, which corresponds to the downlink Tunnel Endpoint Identifier for user data. The target-RNC may be set up to simultaneously receive for each RAB downlink user packets both from the source SRNC and from the new SGSN.

After the new SGSN receives the Relocation Request Acknowledge message, the GTP-U tunnels are established between the target RNC and the new-SGSN.

- 5) When resources for the transmission of user data between the target RNC and the new SGSN have been allocated and the new SGSN is ready for relocation of SRNS, the Forward Relocation Response message (Cause, RANAP Cause, and Target RNC Information) is sent from the new SGSN to the old SGSN. This message indicates that the target RNC is ready to receive from the source SRNC the forwarded downlink packets, i.e., the relocation resource allocation procedure is terminated successfully. RANAP Cause is information from the target RNC to be forwarded to the source SRNC. The RAB Setup Information, one information element for each RAB, contains the RNC Tunnel Endpoint Identifier and RNC IP address for data forwarding from the source SRNC to the target RNC. If the target RNC or the new SGSN failed to allocate resources, the RAB Setup Information element contains only NSAPI indicating that the source SRNC shall release the resources associated with the NSAPI. The Forward Relocation Response message is applicable only in case of inter-SGSN SRNS relocation.
- 6) The old SGSN continues the relocation of SRNS by sending a Relocation Command (RABs to be released, and RABs subject to data forwarding) message to the source SRNC. The old SGSN decides the RABs subject to data forwarding based on QoS, and those RABs shall be contained in RABs subject to data forwarding. For each RAB subject to data forwarding, the information element shall contain RAB ID, Transport Layer Address, and Iu Transport Association. These are the same Transport Layer Address and Iu Transport Association that the target RNC had sent to new SGSN in Relocation Request Acknowledge message, and these are used for forwarding of downlink N-PDU from the source SRNC to the target RNC. The source SRNC is now ready to forward downlink data directly to the target RNC over the Iu interface. This forwarding is performed for downlink user data only.
- 7) Upon reception of the Relocation Command message from the PS domain, the source SRNC shall start the data-forwarding timer.

Note: The order of steps, starting from step 7 onwards, does not necessarily reflect the order of events. For instance, source RNC may send Relocation Commit message (step 7) and starts data forwarding (step 8) almost simultaneously. Target RNC may send Relocation Detect message (step 9) and Cell Update Confirm/URA Update Confirm message (step 10) at the same time. Hence, target RNC may receive the UTRAN Mobility Information Confirm message from MS (step 10) while data forwarding (step 8) is still underway, and before the new SGSN receives Update PDP Context Response message (step 11).

When the source SRNC is ready, the source SRNC shall trigger the execution of relocation of SRNS by sending a Relocation Commit message (SRNS Contexts) to the target RNC over the Iur interface. The purpose of this procedure is to transfer SRNS contexts from the source RNC to the target RNC, and to move the SRNS role from the source RNC to the target RNC. SRNS contexts are sent for each concerned RAB and contain the sequence numbers of the GTP-PDUs next to be transmitted in the uplink and downlink directions and the next PDCP sequence numbers that would have been used to send and receive data from the MS. PDCP sequence numbers are only sent by the source RNC for radio bearers which used lossless PDCP [57]. The use of lossless PDCP is selected by the RNC when the radio bearer is set up or reconfigured. For PDP context(s) using delivery order not required (QoS profile), the sequence numbers of the GTP-PDUs next to be transmitted are not used by the target RNC.

If delivery order is required (QoS profile), consecutive GTP-PDU sequence numbering shall be maintained throughout the lifetime of the PDP context(s). Therefore, during the entire SRNS relocation procedure for the PDP context(s) using delivery order required (QoS profile), the responsible GTP-U entities (RNCs and GGSN) shall assign consecutive GTP-PDU sequence numbers to user packets belonging to the same PDP context for uplink and downlink respectively.

- 8) The source RNC begins the forwarding of data for the RABs subject to data forwarding. The data forwarding at SRNS relocation shall be carried out through the Iu interface, meaning that the GTP-U PDUs exchanged between the source RNC and the target RNC are duplicated in the source RNC and routed at the IP layer towards the target RNC. For each radio bearer using lossless PDCP, the GTP-PDUs corresponding to transmitted but not yet acknowledged PDCP-PDUs are duplicated and routed at IP layer towards the target RNC together with the corresponding downlink PDCP sequence numbers.
- 9) The target RNC shall send a Relocation Detect message to the new SGSN when the relocation execution trigger is received. For SRNS relocation type "UE not involved", the relocation execution trigger is the reception of the Relocation Commit message from the Iur interface. When the Relocation Detect message is sent, the target RNC shall start SRNC operation.
- 10) The target SRNC sends a Cell Update Confirm / URA Update Confirm message. This message contains UE information elements and CN information elements. The UE information elements include among others new SRNC identity and S-RNTI. The CN information elements contain among others Location Area Identification and Routing Area Identification. The procedure shall be co-ordinated in all Iu signalling connections existing for the MS.

Upon reception of the Cell Update Confirm / URA Update Confirm message the MS may start sending uplink user data to the target SRNC. When the MS has reconfigured itself, it sends the UTRAN Mobility Information Confirm message to the target SRNC. This indicates that the MS is also ready to receive downlink data from the target SRNC.

If the new SGSN has already received the Update PDP Context Response message from the GGSN, it shall forward the uplink user data to the GGSN over this new GTP-U tunnel. Otherwise, the new SGSN shall forward the uplink user data to that GGSN IP address and TEID(s), which the new SGSN had received earlier by the Forward Relocation Request message.

The target SRNC and the MS exchange the PDCP sequence numbers; PDCP-SNU and PDCP-SND. PDCP-SND is the PDCP sequence number for the next expected in-sequence downlink packet to be received in the MS per radio bearer, which used lossless PDCP in the source RNC. PDCP-SND confirms all mobile terminated packets successfully transferred before the SRNC relocation. If PDCP-SND confirms the reception of packets that were forwarded from the source SRNC, the target SRNC shall discard these packets. PDCP-SNU is the PDCP sequence number for the next expected in-sequence uplink packet to be received in the RNC per radio bearer, which used lossless PDCP in the source RNC. PDCP-SNU confirms all mobile originated packets successfully transferred before the SRNC relocation. If PDCP-SNU confirms reception of packets that were received in the source SRNC, the target SRNC shall discard these packets.

- 11) Upon receipt of the Relocation Detect message, the CN may switch the user plane from the source RNC to the target SRNC. If the SRNS Relocation is an inter-SGSN SRNS relocation, the new SGSN sends Update PDP Context Request messages (new SGSN Address, SGSN Tunnel Endpoint Identifier, QoS Negotiated) to the GGSNs concerned. The GGSNs update their PDP context fields and return an Update PDP Context Response (GGSN Tunnel Endpoint Identifier) message.
- 12) When the target SRNC receives the UTRAN Mobility Information Confirm message, i.e. the new SRNC-ID + S-RNTI are successfully exchanged with the MS by the radio protocols, the target SRNC shall initiate the Relocation Complete procedure by sending the Relocation Complete message to the new SGSN. The purpose of

the Relocation Complete procedure is to indicate by the target SRNC the completion of the relocation of the SRNS to the CN. If the user plane has not been switched at Relocation Detect, the CN shall upon reception of Relocation Complete switch the user plane from the source RNC to the target SRNC. If the SRNS Relocation is an inter SGSN SRNS relocation, the new SGSN signals to the old SGSN the completion of the SRNS relocation procedure by sending a Forward Relocation Complete message.

13) Upon receiving the Relocation Complete message or if it is an inter-SGSN SRNS relocation, the Forward Relocation Complete message, the old SGSN sends an Iu Release Command message to the source RNC. When the RNC data-forwarding timer has expired the source RNC responds with an Iu Release Complete.

14) After the MS has finished the Cell / URA update and RNTI reallocation procedure and if the new Routing Area Identification is different from the old one, the MS initiates the Routing Area Update procedure. See subclause "Location Management Procedures (UMTS only)". Note that it is only a subset of the RA update procedure that is performed, since the MS is in PMM-CONNECTED state.

CAMEL procedure calls shall be performed; see referenced procedures in 3G TS 23.078:

C1) CAMEL GPRS PDP Context Disconnection and CAMEL GPRS Detach

They are called in the following order:

- The CAMEL GPRS PDP Context Disconnection procedure is called several times: once per PDP context. The procedure returns as result "Continue".
- Then the CAMEL GPRS Detach procedure is called once. The procedure returns as result "Continue".

C2) CAMEL GPRS Routing Area Update-Session

The procedure returns as result "Continue".

C3) CAMEL GPRS Routing Area Update Context.

This procedure is called several times: once per PDP context. It returns as result "Continue".

For C2 and C3: refer to Routing Area Update procedure description for detailed message flow.

## 7.7.4.4 PMM Idle

### 7.7.4.4.1 Routing area update in PMM idle

No changes are required to the Routing Area Update procedures in PMM idle apart from transferring the MBMS context between SGSNs using the existing SGSN Context Response message specified in TS23.060.

### 7.7.4.4.2 RAB set-up in PMM idle.

Core network originated paging may be required to handle UEs in PMM idle state (not Iu connected). This is required to avoid service degradation due to the delay in moving users from idle to cell connected state, if MBMS data streams contain long idle periods during transmission.

Paging of PMM idle users is triggered by data arriving at the SGSN (and for URA-PCH users by data arriving at the RNC).

To avoid data at the beginning of a session being lost whilst the UE is being paged, a "pre-amble" is sent before the "real" user data associated with the stream. This preamble could be for 2 or 3 seconds.

If the SGSN in the data path is not the SGSN the user is registered in, it may be unaware of the users receiving this service, their identity or mobility states.

As a possible solution, paging of the entire area using a paging identifier and DRX parameters specific to the multicast group can be originated at the SGSN(s) when it receives user data without the knowledge of the users.

TMGI is already proposed as a paging identifier for multicast paging originating at the CN. TMGI should be unique within an SGSN coverage area or within a pool area if Iu-flex is used. Paging identifiers within the RAN may be required and is FFS.

## 7.7.5 Service Deactivation and Service Termination

In this section, service deactivation is split into two separate procedures. Firstly service deactivation and secondly data bearer release. For MBMS multicast service deactivation, is user-initiated and occurs either through the use of an “IGMP leave” command to that specific service or PDP context deactivation.

Service termination occurs when the MBMS data reaches the end of its transmission.

### 7.7.5.1 MBMS multicast user-initiated deactivation

#### 7.7.5.1.1 PDP Context deactivation

This involves the standard PDP context deactivation. Normally “IGMP Leave” is expected for user-initiated deactivation, however PDP context deactivation could also occur. Bearer path release where appropriate is given in section 7.6.5.2.

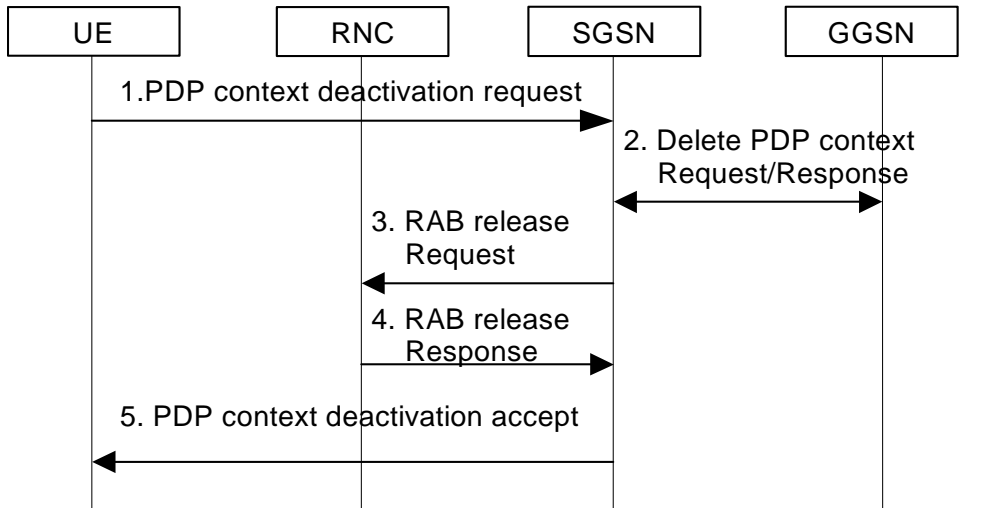

**Figure 73: PDP context deactivation procedure**

1. The UE sends a Deactivate PDP Context Request message to the SGSN.
2. SGSN sends a Delete PDP Context Request to the GGSN that returns a Delete PDP Context response after it removes the PDP context(s).
3. The SGSN sends a RAB release request to the RNC
4. The RNC sends a RAB release response message to the SGSN to complete the RAB release. The SGSN/RNC is aware of the multicast IGMP session associated with this PDP context and, deactivates these locally.

5. [The SGSN returns a Deactivate PDP Context Accept message to the UE.](#)

### 7.7.5.1.2 MBMS Multicast Leave Procedure

[The following procedure is intended to be used in MBMS multicast and involves the use of the appropriate command to remove the individual user from a particular multicast group.](#)

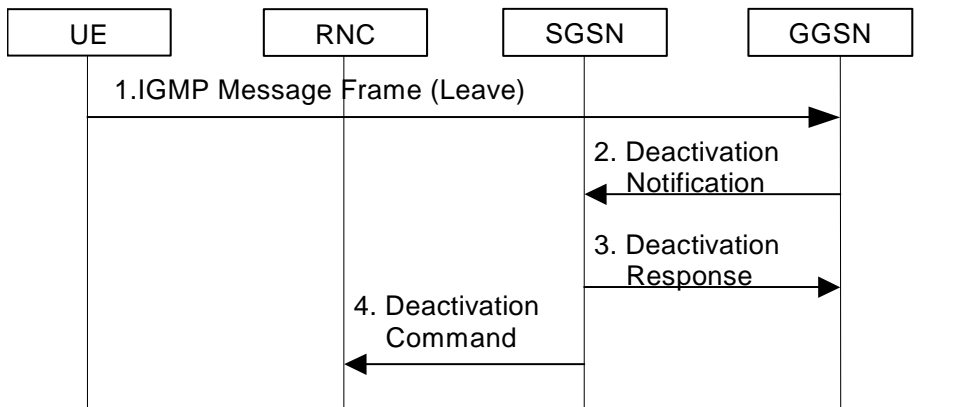
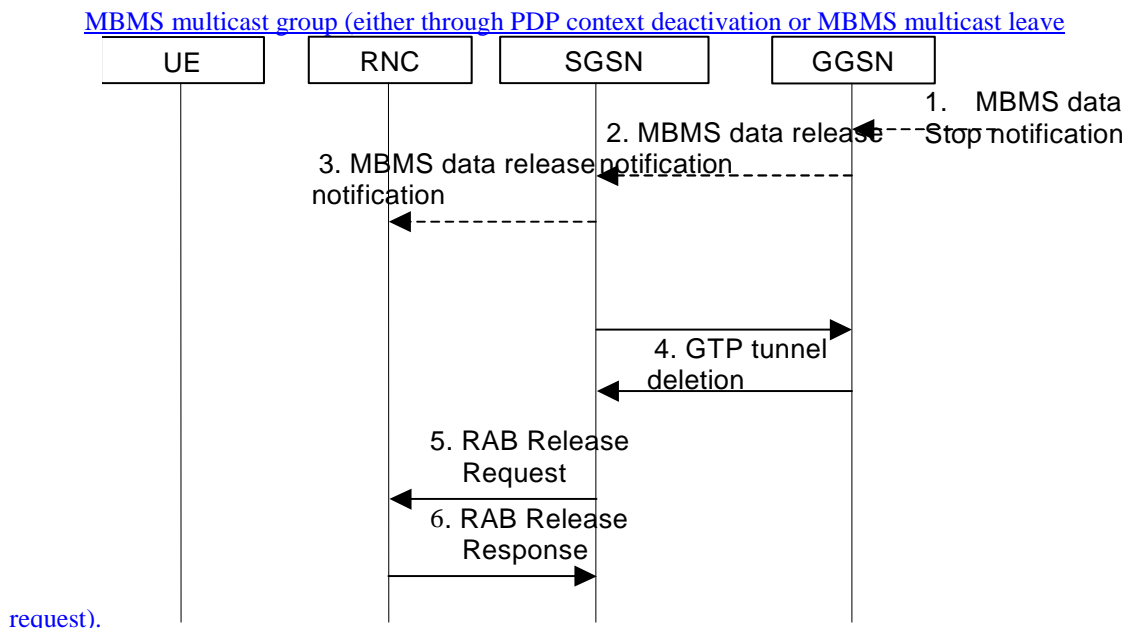

**Figure 74: MBMS Multicast leave procedure**

1. [The UE sends an IGMP “leave” message to the GGSN. This message carries a service deactivation command for the IP address of the MBM multicast service the user wishes to join.](#)
2. [A “Deactivation Notification” message is sent from the GGSN to the SGSN to delete the multicast IP address from the MBMS context. This “Deactivation Notification” can also be initiated if the GGSN receives an “MBMS multicast session stop” request from the data source \(e.g. BM-SC\).](#)
3. [The SGSN sends a “Deactivation Response” message back to the GGSN](#)
4. [The SGSN sends a “Deactivation Notification” message to the RNC. The RNC removes the user from the multicast group.](#)

### 7.7.5.2 MBMS Bearer Release Procedure

[The following bearer release procedure follows either through the termination of the MBMS stream by the network or through user-initiated deactivation \(only for multicast mode\), e.g. the last MBMS multicast user leaves a particular](#)



**Figure 75: MBMS Bearer release procedure**

If the end of an MBMS transmission for multicast or broadcast data is experienced, then RAB release is initiated first by steps 1 to 3 of the following procedure:

1. Data source sends an “MBMS data stop notification” to the GGSN to indicate end of transmission
2. GGSN send a “MBMS data release notification” to the SGSN(s) serving the MBMS users
3. The SGSN(s) send “MBMS data release notification” to all RNC(s) serving MBMS users.

The following steps would follow a user initiated MBMS multicast deactivation, e.g. in Figure 74 above:

4. The SGSN then notifies the GGSN identified by the APN in the MBMS context to perform GTP tunnel deletion for the multicast service
5. “RAB Release Request” is sent to the RNC serving the user(s) from the SGSN
6. “RAB Release Response” is sent from the RNC to the SGSN to release the bearer.

### 7.7.6 Interfaces to External Media Sources

Interfaces from the PLMN will be provided mainly to external sources of MBMS data. These external MBMS sources will be subject to at least the following: -

- Message screening (e.g. through a Firewall)
- Authentication
- Charging
- Prioritisation of content
- Scheduling information for store and forward information

Figure 50 below shows an example of some of the interfaces that could be supported.

MBMS user data is sent to the PLMN under the control of the BMSC. IP Multicast on the Gi interface is assumed.

The following is FFS: -

- [The protocol for the control plane.](#)
- [OSA gateway to perform on-line charging](#)
- [Support of a GUP interface](#)

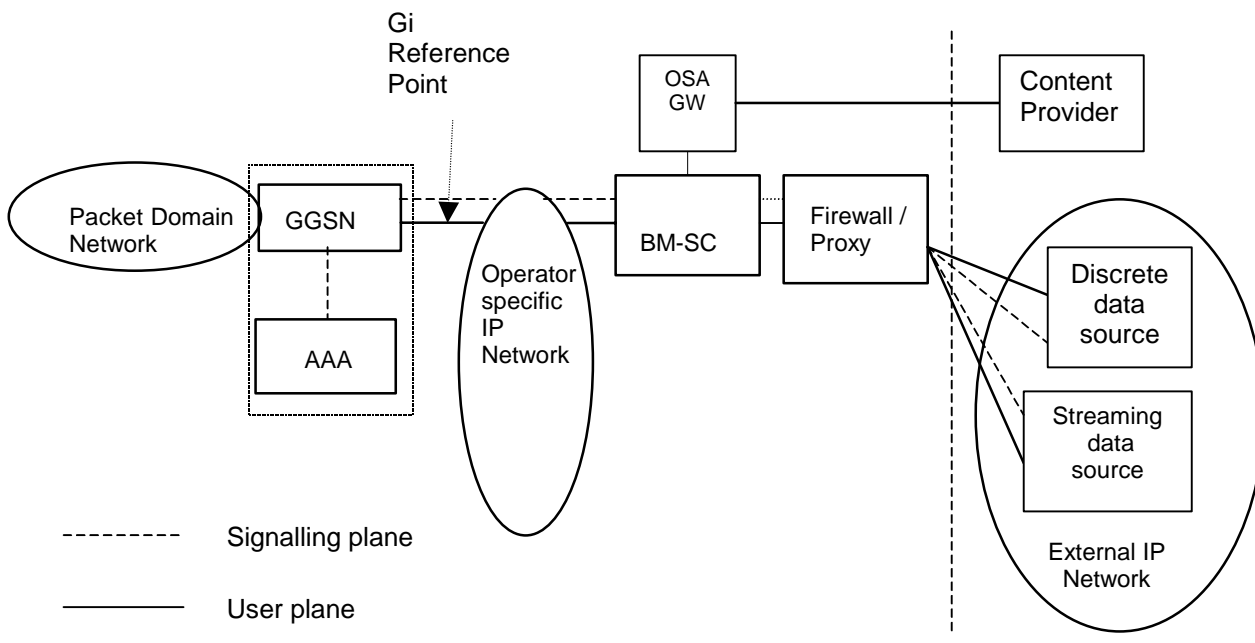

**Figure 76: External interfaces**

## 7.7.7 Roaming

[The architecture supports roaming users without any modifications.](#)

### 7.7.7.1 Services in the HPLMN

[A user in the visited network must choose the GGSN in the home network to receive the home network's MBMS multicast services.](#)

### 7.7.7.2 Services in the VPLMN

[Users may invoke MBMS multicast services in the visited network using the same mechanisms.](#)

## 7.7.8 Security

[Service security can be provided by either encryption at the application layer, under the control of the content provider / network operator, or at RNC level, or both. The process for key distribution is FFS.](#)

## 7.7.9 Charging

[In addition to the charging data collected at the BM-SC, described in Clause 8, additional CDRs for multicast data will be required and created in line with the subscriber-charging model which could include the following: -](#)

[At the GGSN, based on data volume, \(this supports content provider charging\)](#)



At the Default SGSN, based on data stream duration (in the case of services from the visited PLMN)

### 7.7.10 Quality of Service

Several solutions have been proposed to support QoS in MBMS, a couple of options are to use individual flows at a discrete QoS levels or sub-flows that make up the full QoS stream. The flow below supports both of these possibilities. Other methods of handling QoS are not precluded.

In the description below, it is assumed that quality of service is handled by the provision of alternative sub-flows to the GGSN for each discrete data rate available per MBMS multicast service. Multiple flows are in turn sent to UTRAN and it is assumed that mechanisms to autonomously select and adjust the QoS on a cell-by-cell basis according to radio conditions exist in the RAN.

In the following example in Figure 77, the flows correspond to the MBMS multicast RAB setup flows in Sub-clause 7.6.3. The following assumptions apply:

- Only QoS aspects are shown and clarified here
- Only one service is provided in this explanation for clarity although multiple services are supported (e.g. Sport – Football goal of the month video clip)

The Service sub flows are provided at discrete QoS levels. e.g. data rates: A=32kbps, B=64kbps, C=128kbps

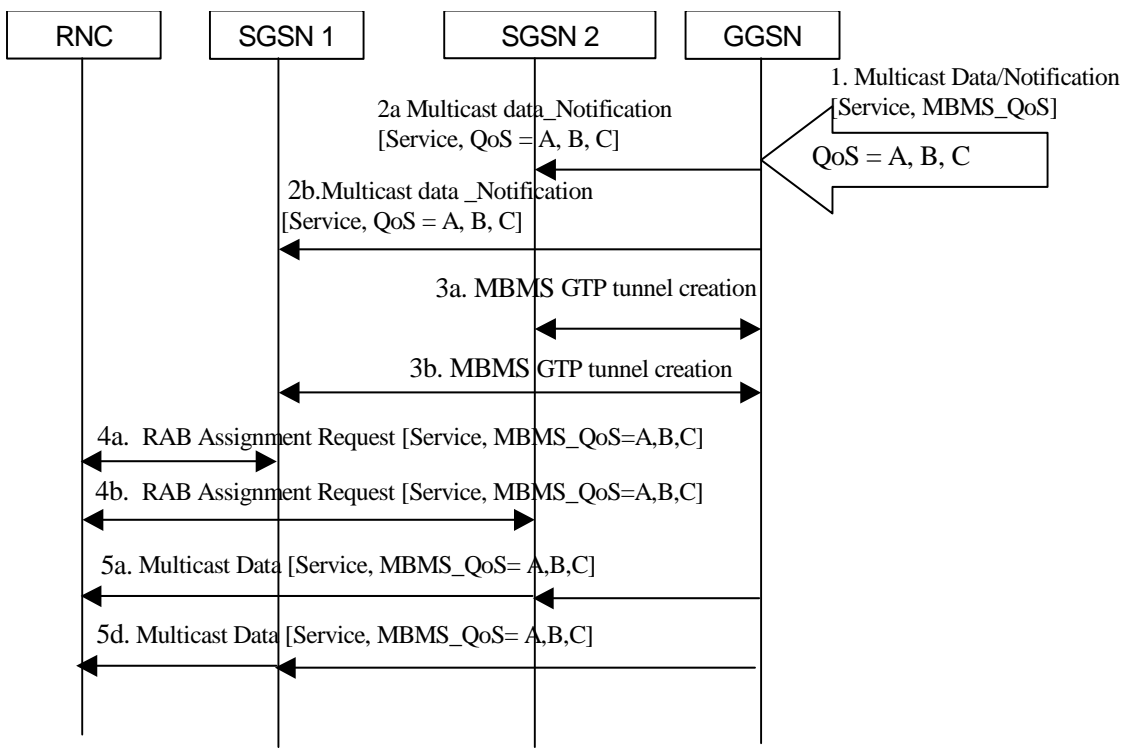

**Figure 77: MBMS QoS Aspects of Multicast RAB set-up**

1. Multicast data provided by data source to GGSN. Service sub flows, one for each QoS level, of a given Service are provided simultaneously. Sub flows are identified in the Service IE. The actual level of QoS for a given Service sub flow identified in the MBMS\_QoS IE e.g:

Flow 1, Service IE= 'Cricket at QoS A/B/C', MBMS\_QoS IE= 'A'

Flow 2, Service IE= 'Cricket at QoS A/B/C', MBMS\_QoS IE= 'B'

Flow 3, Service IE= 'Cricket at QoS A/B/C', MBMS\_QoS IE= 'C'

2. GGSN notifies those SGSNs with multicast users of the multicast service data availability. Notification includes Service IE i.e. Service identifier and Service sub flows (QoS levels)

3. SGSN creates a GTP tunnel to the GGSN for each QoS value provided to the GGSN.

4. Each SGSN sets up necessary RABs to the RNC. The RNC picks SGSN 2 and the appropriate QoS stream from the RAB flows. 5 All streams are delivered to RNC by each SGSN with registered users at that RNC.

After MBMS data flows are established to users, there is the capability for the RNC to dynamically select and deselect MBMS\_QoS levels due to e.g. Cell congestion. The RNC makes decision, based on knowledge of existing flows, to forward a downgraded flow as required by the cell requiring a flow change.

---

## 8 CHARGING

MBMS architecture should provide flexible charging mechanisms for broadcast and multicast modes. This includes support for on-line and off-line charging.

### 8.1 Charging for Broadcast mode

To enable billing of broadcast content providers, data shall be collected at the BM-SC.

In addition to this information listed in the stage 1, data will be needed on the number of cells in the broadcast area.

Examples of the type of the charging information that may be collected at the BM-SC include:

- service time and duration
- volume of data
- MBMS broadcast area
- number of cells in broadcast area

The above list of possible charging mechanisms is neither complete nor exhaustive.

For the Broadcast Mode the BM-SC generates Charging Data Record (CDR) for the billing of the Content Provider.

### 8.2 Charging for Multicast mode

It shall be possible to collect charging information (even when roaming) for the use of the multicast mode. Therefore, the following combinable charging mechanisms should be available for the multicast mode:

#### 8.2.1 Content Provider Charging Mechanism

To enable billing of multicast content providers, data shall be collected at the BM-SC.

In addition content provider CDRs may be generated by the GGSN or by the SGSN. The consolidation of content provider CDRs from BM-SC, SGSN and GGSN may be performed in the Charging Gateway Function (CGF), in the Charging Collection Function (CCF) or in the Billing System (BS).

In addition to this information listed in the stage 1, data will be needed on the number of cells in the multicast area.

Further, information may be needed on the proportion of users to whom the content was satisfactorily delivered-FFS.

Examples of the type of the charging information that should be collected at the BM-SC include:

- service time and duration
- volume of data
- geographic area of multicast area
- number of cells in multicast area

proportion of users who satisfactorily received the multicast is FFS

The above list of possible charging mechanisms is neither complete nor exhaustive.

## 8.2.2 Subscriber Charging

### 8.2.2.1 On-line charging

The architecture should enable the on-line charging of multicast services. To enable this, CAMEL functionality on the SGSN might need to be extended. In addition the CSE may need to interact with the BM-SC to obtain, e.g., rating information. Other solutions to provide on-line charging are not precluded.

### 8.2.2.2 Off-line charging

The Multicast service should enable the user to be charged for the services that they receive. This charging might be either on the volume of data received and/or just on the fact that the user activated the multicast PDP context. SGSN charging data is also needed to handle cases where the SGSN is in a different network to the BM-SC. To achieve this, the SGSN should be able to generate charging information that include at least the following information:

- service time and duration
- volume of data

The above list of possible charging mechanisms is neither complete nor exhaustive.

---

## 9 Interaction with CS/PS services

---

## 10 Information Storage

---

## 11 Conclusions

This Technical report has shown that the support of MBMS within 3GPP is feasible, a number of architectures have been developed that have all demonstrated different possibilities for the control of such a service.

In the development of these architectures, a number of key issues for the stage 2 design have been identified and possible solutions for each issue have been derived from the architectural options described in this technical report.

Decisions on each of these issues need to be taken within the stage 2 design. In addition results from other groups such as SA3 and RAN/GERAN may impact the final architecture.

### 11.1 Identified Key Issues

#### 11.1.1 User initiated Multicast Activation/Deactivation

<u>Proposal</u>	<u>Description</u>
<u>Method 1</u>	<u>MBMS specific activation</u>
<u>Method 2</u>	<u>Transparent IGMP/MLD</u>

#### 11.1.2 Termination node for User specific Activation/Deactivation Signalling

<u>Proposal</u>	<u>Description</u>
-----------------	--------------------

<a href="#">Method 1</a>	<a href="#">At SGSN</a>
<a href="#">Method 2</a>	<a href="#">At GGSN</a>
<a href="#">Method 3</a>	<a href="#">At BMSC</a>

### 11.1.3 Gn: Set-up of Transport Resources for Multicast

<b><u>Proposal</u></b>	<b><u>Description</u></b>
<a href="#">Method 1</a>	<a href="#">Transport is set-up as required upon notification from BMSC</a>
<a href="#">Method 2</a>	<a href="#">Transport is set-up upon initial activation</a>

### 11.1.4 RAB set-up

<b><u>Proposal</u></b>	<b><u>Description</u></b>
<a href="#">Method 1</a>	<a href="#">Upon explicit Notification to SGSN</a>
<a href="#">Method 2</a>	<a href="#">Upon data arrival at SGSN</a>
<a href="#">Method 3</a>	<a href="#">On first user activation at RNC</a>

### 11.1.5 Gn: Transport set up for Broadcast

<b><u>Proposal</u></b>	<b><u>Description</u></b>
<a href="#">Method 1</a>	<a href="#">Transport is set-up as required upon notification from BMSC</a>
<a href="#">Method 2</a>	<a href="#">SGSN initiated by OAM</a>

### 11.1.6 Per-UE MBMS RAB signalling connection

<b><u>Proposal</u></b>	<b><u>Description</u></b>
<a href="#">Method 1</a>	<a href="#">Yes</a>
<a href="#">Method 2</a>	<a href="#">No</a>

### 11.1.7 Handling of MBMS data for PMM Idle users

<b><u>Proposal</u></b>	<b><u>Description</u></b>
<a href="#">Method 1</a>	<a href="#">Using NAS paging triggered by data arrival/notification at SGSN to move UE to PMM connected</a>
<a href="#">Method 2</a>	<a href="#">Reception is enabled in PMM idle</a>

### 11.1.8 MBMS Transport for Iu/Gn

<b><u>Proposal</u></b>	<b><u>Description</u></b>

<a href="#">Method 1</a>	<a href="#">GTP over IP Unicast</a>
<a href="#">Method 2</a>	<a href="#">GTP over IP Multicast</a>

### 11.1.9 Storage of MBMS Service Parameters

<u>Proposal</u>	<u>Description</u>
<a href="#">Method 1</a>	<a href="#">BMSC</a>
<a href="#">Method 2</a>	<a href="#">SGSN</a>

### 11.1.10 Security: Authentication & Ciphering key provision to ue

<u>Proposal</u>	<u>Description</u>
<a href="#">Method 1</a>	<a href="#">Application Layer</a>
<a href="#">Method 2</a>	<a href="#">Network Layer</a>

### 11.1.11 Ciphering

<u>Proposal</u>	<u>Description</u>
<a href="#">Method 1</a>	<a href="#">Application Layer</a>
<a href="#">Method 2</a>	<a href="#">Network Layer</a>

### 11.1.12 Handling of services with multiple media components

<u>Proposal</u>	<u>Description</u>
<a href="#">Method 1</a>	<a href="#">Combination of media components to one IP Multicast address, (separated by ports)</a>
<a href="#">Method 2</a>	<a href="#">Separate multicast address for each media component</a>

---

## Annex A: Comparison of Architectural Options

The following tables provide a comparison of the different architectural options presented in section 7. Two tables are provided one for multicast mode and a second one for broadcast mode. Note that the tables present the individual views as put forward by contributors of each of the options.

## A.1 Multicast Mode

<u>Characteristics</u>	<u>Option A</u>	<u>Option B</u>	<u>Option C</u>	<u>Option E</u>	<u>Option G</u>
<p><u>QoS Determination</u></p> <p><u>Configured by PLMN Operator.</u></p> <ul style="list-style-type: none"> <li><u>Home Environment shall be able to set priority</u></li> <li><u>In Multicast mode possible to provide different QoS provided to different multicast area associated with same service</u></li> <li><u>In Multicast mode possible to provide different QoS provided to over different sessions. .</u></li> </ul>	<ul style="list-style-type: none"> <li><u>The PLMN operator configures the QoS of each MBMS service by the set of parameters defined for PDP contexts</u></li> <li><u>The QoS configuration includes the priority parameter which may be evaluated by the RAN at transmission and by UEs to differentiate between multiple parallel services</u></li> <li><u>A service may be composed of multiple media components and the components may be split further into layers; for each area or cell the RAN may decide on the number of transferred components/layers</u></li> <li><u>In the same way different sessions may use only subsets of the configured components/layers</u></li> </ul>		<p><u>Maximal QoS is configured by PLMN operator. Configuration is stored at the BM-SC. QoS differentiation between different areas and across time-bounded sessions is possible as well.</u></p>	<p><u>QoS profiles are provided by the BM-SC.</u></p> <p><u>Home Environment can set the priority through BM-SC. Gmb interface supports QoS policy control for MBMS by the BM-SC.</u></p> <p><u>Different QoS is provided to different areas through usage of different multicast addresses and different service activation by the UE.</u></p> <p><u>Different QoS to different sessions can be provided through application of different multicast addresses. The BM-SC provides QoS per session to GGSN via Gmb interface.</u></p>	<p><u>Either QoS alternatives or QoS sub-flows could be made available by content provider/data source. Input is required from SA4 and RAN2 on final handling requirements.</u></p> <p><u>QoS required for a particular service, (including QoS alternatives, if available) is configured in the BMSC.</u></p> <p><u>QoS attributes for the service are sent to GGSN, from GGSN to SGSN (where multicast users are registered) and SGSN to RNC in the notification message.</u></p> <p><u>GGSN is responsible for making MBMS data GTP tunnels available at one or more QoS alternative</u></p> <p><u>QoS attributes including priority can be indicated to the serving SGSN by the GGSN in the home environment.</u></p> <p><u>Actual QoS provided is determined by radio conditions. Network based priority for simultaneous services will be governed by these conditions and based on the priority information</u></p>



					<p><u>provided by BMSC.</u></p> <p><u>Actual QoS delivered is determined by RAN . If RAN is able to decide, then it is possible to provide different QoS in different cells, hence different multicast areas.</u></p>
<u>Activation of multicast services</u>	<u>Is provided, see procedures. Comparable to PDP context activation.</u>		<u>Supported.</u>	<u>Activation of the MBMS service is performed by the UE.</u>	<u>The join message uses the IETF defined IGMP/MLD frame. This message carries the IP multicast destination address of the service.</u>
<p><u>User Mobility</u></p> <ul style="list-style-type: none"> <li><u>Core Network user Mobility.</u></li> </ul> <p><u>The user shall be able to continue to receive service in multicast area even when SGSN change. occurs.</u></p> <ul style="list-style-type: none"> <li><u>Access Network user mobility</u></li> </ul>	<ul style="list-style-type: none"> <li><u>MBMS users are in idle mode from the Core Network point of view. If user change between SGSNs they get from the RAN the parameters for the new MBMS radio bearer and from the SGSN by a RAU a new key if the key changes.</u></li> <li><u>Within the RAN the UEs perform a kind of network assisted cell change to find the MBMS radio bearer in the new cell; details are for RAN2.</u></li> </ul>		<p><u>Both core-network and access-network user mobility are supported.</u></p> <p><u>Use of SRNC as source of data for CRNC is assumed.</u></p>	<p><u>Core network UE mobility similar as available for point-to-point services. UE will receive the service even in case of change of SGSN, with or without CN being informed (due to Iur) as UTRAN knows UE interested in the service.</u></p> <p><u>Access network mobility followed by the UTRAN as the UTRAN knows each UE interested in the service as for non-MBMS services.. To be worked out by 3GPP RAN groups.</u></p>	<p><u>Existing MM procedures are used that allow SGSN and RNC to track multicast users and provide service continuity.</u></p> <p><u>SGSN user specific MBMS context is passed between SGSNs using existing messages.</u></p> <p><u>RNC provides service continuity by tracking users at cell level using existing RAN mobility procedures.</u></p>
<u>MBMS Paging</u>	<u>The MBMS RABs may be released. If MBMS data arrive in the SGSN, the SGSN pages within the MBMS service area to establish MBMS RABs</u>		<p><u>Supported.</u></p> <p><u>Architecture allows for a very long MBMS paging enabling multiple UEs to be paged and respond.</u></p>	<p><u>NAS Paging is performed for multicast if a UE that has activated the service is in IDLE mode like for a point-to-point non-MBMS paging. NAS paging is not necessary if the UE is in PMM-CONNECTED mode. RRC Paging may be needed.</u></p>	<p><u>In order to account for discontinuous multicast with idle periods, this option supports a paging mechanism in order to avoid the UE/MS having to monitor the multicast channel at all times and hence conserve battery power.</u></p> <p><u>NAS initiated paging (for PMM IDLE users) and RNC initiated paging is triggered</u></p>

					<p><a href="#">by the “MBMS data notification” message</a></p> <p><a href="#">To help mitigate the potential loss of data transmission to UEs during paging, a service preamble is used at the start of multicast transmissions.</a></p>
<p><a href="#">Resource Efficiency</a></p> <ul style="list-style-type: none"> <li><a href="#">• Iu user plane</a></li> <li><a href="#">• Gn</a></li> <li><a href="#">• Radio</a></li> </ul>	<p><a href="#">Only shared RABs are used for data transfer. RABs (radio and Iu bearers) are released when there are no more data to transfer. Separation into multiple components/layers results in resource usage/reservation only for components/layers which are in the actual session.</a></p> <p><a href="#">On Gn resources are only used when data are transferred.</a></p>		<p><a href="#">Single bearer is used over Gn, Iu, and Radio interface. No preference as to Iu-flex solution.</a></p>	<p><a href="#">Iu user plane and Gn may be shared per MBMS service.</a></p> <p><a href="#">Radio solution is to be determined in 3GPP RAN groups.</a></p>	<p><a href="#">Multiple users on the same group share a common RAB.</a></p> <p><a href="#">Multiple users on the same group share a common GTP-U tunnel (over IP unicast).</a></p> <p><a href="#">Single Control Plane for common multicast messages, e.g. RAB establishment message for a multicast channel.</a></p> <p><a href="#">Possibility to set-up bearers only when there is data to be sent.</a></p> <p><a href="#">Since RNC is aware of start and end points of data streams, (using notification messages), RAN is able to make better use of radio resources.</a></p> <p><a href="#">On the radio, the use of IGMP would reduce the signaling associated with the activation process compared with PDP context activation. User sends IGMP as and when he wishes to join services.</a></p>
<p><a href="#">Deactivation of service</a></p> <ul style="list-style-type: none"> <li><a href="#">• By user</a></li> <li><a href="#">• By operator</a></li> </ul>	<p><a href="#">The service deactivation procedure is comparable to the PDP context deactivation which also may be initiated by the user or by the network</a></p>		<p><a href="#">Supported.</a></p>	<p><a href="#">Deactivation can, as with ‘regular’ PDP sessions, be done by the user</a></p> <p><a href="#">Deactivation by the operator (via BM-SC) should be</a></p>	<p><a href="#">User can deactivate by sending explicit leave command, or by PDP context deactivation. He then leaves the group (i.e. user’s association with a particular</a></p>

				<a href="#">possible FFS</a>	<a href="#">group is removed).</a>  <a href="#">A new signaling procedure is introduced to perform a user initiated leave command. IGMP/MLD “leave” command is sent from UE to GGSN to initiate the deletion of the user’s MBMS context from the GGSN and SGSN.</a>  <a href="#">Network initiated multicast service transmission is supported by use of a “MBMS_data_stop” notification message from the BMSC to GGSN.</a>
<a href="#">Joining of multicast group by home environment</a>	<a href="#">FFS whether SGSN initiates the activation/join based on subscription data or whether data on the SIM initiate the join/activation without user interaction</a>		<a href="#">Possible.</a>	<a href="#">Joining of a multicast group by the home environment can be performed in the BM-SC</a>	<a href="#">Based on subscription information, the user can be notified of services. This notification message can be sent at attach. Upon notification, the UE could send an automated IGMP join command to join the group.</a>
<a href="#">User Selectivity</a>  <a href="#">• User shall be able to discover service available.</a>  <a href="#">• User shall also be able to select between different multicast services provided to the user and can receive simultaneously more than one service.</a>	<a href="#">The user receives service announcements preferably on a well known MBMS broadcast service.</a>  <a href="#">The procedures support per user multiple active MBMS services in parallel. The mechanisms to transfer data from multiple services in parallel is RAN functionality and under study in RAN. The number of parallel transmissions will depend on RAN and UE capabilities.</a>		<a href="#">Supported.</a>	<a href="#">User can discover MBMS services through agreed methods in TR 23.846.</a>  <a href="#">User can select between different multicast services through activation of MBMS contexts for a particular service.</a>  <a href="#">User can simultaneously receive other services and multiple MBMS services in parallel.</a>	<a href="#">Service announcement / discovery involves the user acquiring information required to join a multicast service, e.g. APN, IP address.</a>  <a href="#">Architecture is not tied to any particular service announcement or discovery method.</a>  <a href="#">Reception of multiple simultaneous services is dependent on UE capability. Architecture permits this by use of explicit multiple join command; user has control of which services he wishes to access and at what time.</a>

<a href="#">Notification of arrival of data.</a>	<a href="#">The paging by TMGI is used to notify UEs that the MBMS radio bearer is setup. If the bearer is established no further notification is needed.</a>		<a href="#">Yes.</a>	<a href="#">Notification of arrival of data supported.</a>	<a href="#">"MBMS data notification" message to indicate the imminent arrival of data is sent to all SGSNs where users are registered and subsequently to the appropriate RNCs.</a>
<a href="#">O&amp;M (related data storage)</a>	<a href="#">MBMS contexts are configured in the SGSN for broadcast and multicast services.</a>		<a href="#">Mostly in BM-SC. User permissions in HLR/HSS.</a>	<a href="#">Required O&amp;M operations similar to point-to-point services.</a>	<a href="#">Service related OA&amp;M data is to be configured only in the BM-SC.</a>
<a href="#">Bearer release</a>	<a href="#">MBMS RAB release may be initiated by the RAN or by the SGSN when there are no more data to transfer. Gn bearers may be released if no more users are in the SGSN.</a>		<a href="#">Yes.</a>	<a href="#">Bearers release similar to point-to-point services.</a>	<a href="#">GGSN initiated release at service termination or user initiated release if he is the last user.</a>
<a href="#">User charging</a>	<a href="#">For multicast the SGSN creates user CDRs comparable to GPRS PDP CDRs.</a>		<a href="#">At AGSN.</a>	<a href="#">Charging based both on MBMS context activation and volume data transported by the network (no requirement to acknowledge the reception of data)</a>	<a href="#">A default charging scheme based on service activation is supported. CDRs for volume of data transferred per session can be generated at the SGSN.</a>
<a href="#">Content provider charging</a>	<a href="#">The BM-SC generates CDRs for the content providers.</a>		<a href="#">At BM-SC.</a>	<a href="#">Charging information provided by BM-SC</a>	<a href="#">Content provider charging will be performed at the GGSN/BMSC.</a>
<a href="#">Support of roaming</a>	<a href="#">The visited operator must allow the activation of multicast services from other operators by configuration. Multicast subscription comparable to GPRS PtP HLR contexts which support roaming.</a>  <a href="#">Multicast services offered by the visited network may be used by using the MBMS APN of the visited network. These services must not require service individual subscriptions.</a>		<a href="#">Supported.</a>	<a href="#">Similar to point-to-point services with service activation via a HPLMN GGSN to the HPLMN BM-SC.</a>	<a href="#">Roaming is supported using existing roaming mechanisms</a>

## A.2 Broadcast Mode

<u>Characteristics</u>	<u>Option A</u>	<u>Option B</u>	<u>Option C</u>	<u>Option E</u>	<u>Option G</u>
<u>QoS Determination</u> <ul style="list-style-type: none"> <li>• <u>Configured by PLMN Operator.</u></li> <li>• <u>Home Environment shall be able to set priority</u></li> <li>• <u>In Broadcast mode possible to provide different QoS provided to different Broadcast area associated with same service</u></li> <li>• <u>In Broadcast mode possible to provide different QoS provided to over different sessions..</u></li> </ul>	<ul style="list-style-type: none"> <li>• <u>The PLMN operator configures the QoS of each MBMS service by the set of parameters defined for PDP contexts</u></li> <li>• <u>The QoS configuration includes the priority parameter which may be evaluated by the RAN at transmission and by UEs to differentiate between multiple parallel services</u></li> <li>• <u>A service may be composed of multiple media components and the components may be split further into layers; for each area or cell the RAN may decide on the number of transferred components/layers</u></li> </ul> <p><u>In the same way different sessions may use only subsets of the configured components/layers</u></p>		<p><u>QoS is configured by PLMN operator. Configuration is stored at the BM-SC. QoS differentiation between different areas and across time-bounded sessions is possible as well.</u></p>	<p><u>QoS profile determined by the BM-SC.</u></p> <p><u>Home Environment can set the priority through BM-SC. Gmb interface supports QoS policy control for MBMS by the BM-SC.</u></p> <p><u>Different QoS and different areas can be provided through activation of different broadcast services. The BM-SC provides QoS per session to GGSN via Gmb interface.</u></p>	<p><u>Generally the same as for multicast mode.</u></p> <p><u>QoS alternatives are made available to all appropriate SGSNs in the broadcast area.</u></p> <p><u>QoS attributes including priority can be indicated to the serving GGSN by the GGSN in the home environment.</u></p> <p><u>Actual QoS delivered is determined by RAN. If RAN is able to decide, then it is possible to provide a service with different QoS in different cells, hence to different broadcast areas.</u></p>
<u>Activation of Broadcast services</u>	<p><u>Is performed locally in the UE and in the network, see procedures.</u></p>		<p><u>Supported.</u></p>	<p><u>Performed by the BM-SC. No UE activation of the broadcast service.</u></p>	<p><u>No explicit activation signaling required for broadcast mode. Service reception is carried out locally on UE by the user</u></p>
<u>User Mobility</u> <ul style="list-style-type: none"> <li>• <u>Core Network user Mobility.</u></li> </ul>	<ul style="list-style-type: none"> <li>• <u>MBMS users are in idle mode from the Core Network point of view. If user change between</u></li> </ul>		<p><u>Both core-network and access-network user mobility is supported.</u></p>	<p><u>The user receive MBMS broadcast service in the broadcast area.</u></p>	<p><u>Service is available over entire broadcast area independent of user mobility or location.</u></p>

<p><u>The user shall be able to continue to receive service in Broadcast area even when SGSN change. occurs.</u></p> <ul style="list-style-type: none"> <li><u>Access Network user mobility</u></li> </ul>	<p><u>SGSNs they get from the RAN the parameter for the new MBMS radio bearer.</u></p> <ul style="list-style-type: none"> <li><u>Within the RAN the UEs perform a kind of network assisted cell change to find the MBMS radio bearer in the new cell; details in RAN2.</u></li> </ul>			<p><u>Access network receives broadcast data and limit the distribution area to the broadcast service area.</u></p>	<p><u>mobility or location.</u></p>
<p><u>MBMS Paging</u></p>	<p><u>The MBMS RABs may be released. If MBMS data arrive in the SGSN, the SGSN pages within the MBMS service area to establish MBMS RABs</u></p>		<p><u>Supported</u></p>	<p><u>No NAS paging as broadcast data is broadcasted without taking into account Ues in the CN.</u></p> <p><u>3GPP RAN groups need to decide on details.</u></p>	<p><u>In order to account for discontinuous broadcasts with idle periods, this option supports a paging mechanism in order to avoid the UE/MS having to monitor the broadcast channel at all times and hence conserve battery power.</u></p> <p><u>NAS initiated paging (for PMM IDLE users) and RNC initiated paging is triggered by the “MBMS data notification” message</u></p> <p><u>To help mitigate the potential loss of data transmission to UEs during paging, a service preamble is used at the start of multicast transmissions.</u></p>
<p><u>Resource Efficiency</u></p> <ul style="list-style-type: none"> <li><u>Iu user plane</u></li> <li><u>Gn</u></li> <li><u>Radio</u></li> </ul>	<p><u>Only shared RABs are used for data transfer. RABs (radio and Iu bearers) are released when there are no more data to transfer. Separation into multiple components/layers results in resource usage/reservation only for components/layers which are</u></p>		<p><u>Single bearer is used over Gn, Iu, and Radio interface. No preference as to Iu-flex solution.</u></p>	<p><u>same as for Multicast service</u></p>	<p><u>Broadcast transmissions share a common RAB and a common GTP-U tunnel (over IP unicast).</u></p> <p><u>Single Control Plane for common multicast messages, e.g. RAB establishment message for a</u></p>

	<p><u>in the actual session.</u></p> <p><u>On Gn resources are only used when data are transferred.</u></p>				<p><u>multicast channel.</u></p> <p><u>Possibility to set-up bearers only when there is data to be sent.</u></p> <p><u>Since RNC is aware of start and end points of data streams, (using notification messages), RAN is able to make better use of radio resources.</u></p>
<p><u>Deactivation of service</u></p> <ul style="list-style-type: none"> <li>• <u>By user</u></li> <li>• <u>By operator</u></li> </ul>	<p><u>The service deactivation is performed locally on the UE or in the network, respectively.</u></p>		<p><u>Deactivation by user only.</u></p>	<p><u>UE deactivate the service without informing the network.</u></p> <p><u>Operator can deactivate the service through BM-SC.</u></p>	<p><u>The display of broadcast services may be stopped by user by local interaction with terminal. No signaling is required to the network.</u></p> <p><u>Since operator has no "knowledge" of users for broadcast data, deactivation of individual users is not possible. Service termination by operator is performed when the MBMS data session stops.</u></p>
<p><u>Joining of Broadcast group by home environment</u></p>	<p><u>No requirement but activation based on the SIM would be possible.</u></p>		<p><u>Not possible for broadcast.</u></p>	<p><u>FFS</u></p>	<p><u>Broadcast services are normally characterized by geographical area. Users may receive broadcast data as a result of being in a particular broadcast area not as a result of joining a group</u></p>
<p><u>User Selectivity</u></p> <ul style="list-style-type: none"> <li>• <u>User shall be able to discover service available.</u></li> <li>• <u>User shall also be able to select between different Broadcast services provided to the user and can receive simultaneously more than one service.</u></li> </ul>	<p><u>The user receives service announcements preferably on a well known MBMS broadcast service. The procedures support per user multiple active MBMS services in parallel. The mechanisms to transfer data from multiple services in parallel is RAN functionality</u></p>		<p><u>Supported</u></p>	<p><u>Services can be discovered by UE through announcement and notification before data transfer.</u></p> <p><u>UE capabilities will indicate whether the UE is able to select between different broadcast services available, and can receive simultaneously more than one service</u></p>	<p><u>Service announcement / discovery of broadcast services may be possible either at subscription or through CBS or MBMS broadcast capabilities itself. Architecture is not tied to any particular service announcement or discovery method for broadcast.</u></p>

<a href="#">than one service.</a>	<a href="#">and under study in RAN. The number of parallel transmissions will depend on RAN and UE capabilities.</a>			<a href="#">than one service</a>	<a href="#">method for broadcast.</a> <a href="#">Reception of multiple simultaneous broadcast services is dependent on UE capability.</a>
<a href="#">Notification of arrival of data.</a>	<a href="#">The paging by TMGI is used to notify UEs that the MBMS radio bearer is setup. If the bearer is established no further notification is needed.</a>		<a href="#">Yes.</a>	<a href="#">Yes</a>	<a href="#">“MBMS data notification” message to indicate the imminent arrival of broadcast data is sent to all SGSNs (appropriate to the broadcast area) and subsequently to the appropriate RNCs.</a> <a href="#">This message is used is for example the broadcast service is streamed video</a>
<a href="#">O&amp;M (related data storage)</a>	<a href="#">MBMS contexts are configured in the SGSN for broadcast and multicast services.</a>		<a href="#">Mostly in BM-SC. User permissions in HLR/HSS.</a>	<a href="#">Data storage per service (instead of per user)</a>	<a href="#">Service related OA&amp;M data is to be configured only in the BM-SC.</a>
<a href="#">Bearer release</a>	<a href="#">MBMS RAB release may be initiated by the RAN or by the SGSN when there are no more data to transfer.</a>		<a href="#">Yes.</a>	<a href="#">Bearer release at end of service.</a>	<a href="#">GGSN initiated release at service termination.</a>
<a href="#">User charging</a>	<a href="#">User charging is not required.</a>		<a href="#">Not supported for broadcast.</a>	<a href="#">Charging in principle for content provider.</a>	<a href="#">CDRs for volume of data transferred per session can be generated at the SGSN.</a>
<a href="#">Content provider charging</a>	<a href="#">The BM-SC generates CDRs for the content providers.</a>		<a href="#">At BM-SC.</a>	<a href="#">Through BM-SC</a>	<a href="#">Content provider charging will be performed at the GGSN/BMSC.</a>
<a href="#">Support of roaming</a>	<a href="#">The UEs may receive any broadcast service the visited network provides at the UE's location.</a>		<a href="#">Supported.</a>	<a href="#">FFS</a>	<a href="#">Roaming is supported using existing roaming procedures</a>



## Annex B:

# Comparison of MBMS Multicast Service Activation Alternatives

Two main alternatives for the MBMS Multicast Service Activation have been identified in this study of the MBMS architecture:

- 1) MBMS-specific signalling initiated by the UE, possibly triggered by an IGMP/MLD message terminated in the MT.  
Hereafter referred to as “MBMS-specific activation” for simplicity.
- 2) IGMP/MLD messages sent over a previously activated PDP context up to the GGSN, followed by a network-initiated MBMS Context set-up.  
Hereafter referred to as “Transparent IGMP/MLD” for simplicity.

One major requirement in terms of MBMS multicast service activation is the interoperability with IP multicast as defined in the IETF, i.e. IGMP (for IPv4) and MLD (for IPv6), and is the base for the short comparison between the two alternatives in Table 1.

**Table 1: MBMS-specific multicast activation vs. transparent IGMP/MLD**

	<u>MBMS-specific activation</u>	<u>Transparent IGMP/MLD</u>
<u>MT functionality in split terminal case</u>	<u>IGMP/MLD terminated in MT, which therefore must implement multicast router functionality.</u>	<u>IGMP/MLD terminated in GGSN, completely transparent to MT, i.e. no IGMP/MLD specific functionality in MT.</u>
<u>Co-existence with transparent IP multicast</u>	<u>In split terminal configuration, TE sending Join request to a non-MBMS IP multicast group would always initiate MBMS Context Activation from the MT, even if it will eventually fail.</u>  <u>Note: This might preclude supporting transparent IP multicast in parallel with MBMS.</u>	<u>GGSN receives Join request and determines whether MBMS or non-MBMS multicast group. If non-MBMS multicast group, then GGSN acts as standard IP multicast router.</u>
<u>Coupling between 3GPP and IETF standards</u>	<u>To support future extensions of IGMP/MLD would require updating 3GPP standards and upgrading UE (at least in split terminal case), SGSN, GGSN and possibly BM-SC.</u>	<u>To support future extensions of IGMP/MLD would require upgrading UE (MT not impacted in split terminal case), GGSN and possibly BM-SC. The SGSN may have to be upgraded as well, but very unlikely<sup>1</sup>. Minimum or no changes to 3GPP standards.</u>
<u>IGMP/MLD periodic queries</u>	<u>Not applicable.</u>	<u>IGMP/MLD periodic queries sent over the air, but frequency is configured in GGSN and can be set to high value.</u>  <u>Only a few UEs will have to reply</u>

		<a href="#"><u>and only needs a few replies.</u></a>
<a href="#"><u>Acknowledgment of Join/Leave request</u></a>	<p><a href="#"><u>MBMS Context Activation/Deactivation will be acknowledged at UMTS level, but IGMP/MLD has no acknowledgment defined, hence MT cannot forward acknowledgements to TE.</u></a></p> <p><a href="#"><u>Extension of IGMP/MLD in IETF to introduce acknowledgement mechanism would be required.</u></a></p>	<p><a href="#"><u>IGMP/MLD has no acknowledgement defined.</u></a></p> <p><a href="#"><u>Extension of IGMP/MLD in IETF to introduce acknowledgement mechanism would be required.</u></a></p>
<a href="#"><u>Dependency on established PDP context</u></a>	<p><a href="#"><u>Not dependent on established PDP context.</u></a></p> <p><a href="#"><u>Note: In split terminal case, it is expected that a PDP context will anyway be established.</u></a></p>	<a href="#"><u>Requires pre-established PDP context.</u></a>

[Note 1: IGMP/MLD is an IP layer protocol, hence extensions to IGMP/MLD are expected to relate to IP layer functionality. Since the SGSN treats the user IP layer transparently, any extensions to IGMP/MLD will very likely not affect the SGSN when IGMP/MLD is transported transparently through the GPRS network.](#)

---

## Annex C

This section contains text for information

### C.1 Decision process for selection of point-to-point or point-to-multipoint configuration

For GSM, one way to achieve this would be for the paging messages which carry the TMGI to also specify the value to be included by the mobile into any subsequent (Packet) Channel Request message. After receiving a page with their TMGI, each mobile sends one (Packet) Channel Request message with the value specified in the page message. The BSS then counts the number of (Packet) Channel Request messages containing the specified contents received in each cell. This method seems likely to give an accurate measure of either (a) how many mobiles belonging to that group are in the cell (if there are less than, say, 10 mobiles in the cell), or (b) whether there are more than, say, 10 mobiles belonging to that group in the cell.

For UMTS: the method is FFS

### C.2 One Tunnel vs. Multiple Tunnels

When only one GTP tunnel exists between the GGSN and the SGSN, the SGSN must

- Be able to create multiple GTP tunnels between itself and the RNCs serving MBMS receivers.
- Be able to duplicate MBMS data packets to these tunnels (between the SGSN and the RNCs) coming from the GGSN.

The other alternative of having only one GTP tunnel between the GGSN and the SGSN is to have multiple tunnels between these elements, i.e. one GTP tunnel for each RNC serving the MBMS receivers. These approaches are illustrated in .

By having multiple tunnels, several benefits can be gained:

- There is no need to make changes to the current packet relaying in the SGSN. The SGSN does not have to duplicate packets from a Gn/Gp GTP tunnel to multiple Iu GTP tunnels.
- QoS handling does not require changes to the SGSN. With this approach RNCs may be able to provide different QoS, even though these RNCs would reside below the same SGSN. In the "one GTP tunnel between the GGSN and the SGSN" approach new logic is required in the SGSN to determine the QoS for the Gn/Gp tunnel.
- RAB release and Iu release do not require changes to the SGSN. Again, in the "one GTP tunnel between the GGSN and the SGSN" approach new logic is required in the SGSN to carry out these procedures.
- According to TS 22.146 (Chapters 5.1.1 and 5.2.1) and TR 23.846 (Chapter 6.1.2), it should be possible to send different data to different service areas for the same service (e.g. regional news). When multiple tunnels are used, different data can be flexibly sent to different RNCs (serving different service areas).

Thus, the approach of having multiple tunnels reuses the existing mechanisms and minimizes the changes to the existing infrastructure (architecture principle 4, in TR 23.846), but the expense is that the same data is delivered between the GGSN and the SGSN multiple times. When compared to the approach of having one tunnel, the situation is the opposite: in the solution utilizing one Gn/Gp tunnel new complicated logic is required, but the data is delivered only once between the GGSN and the SGSN.

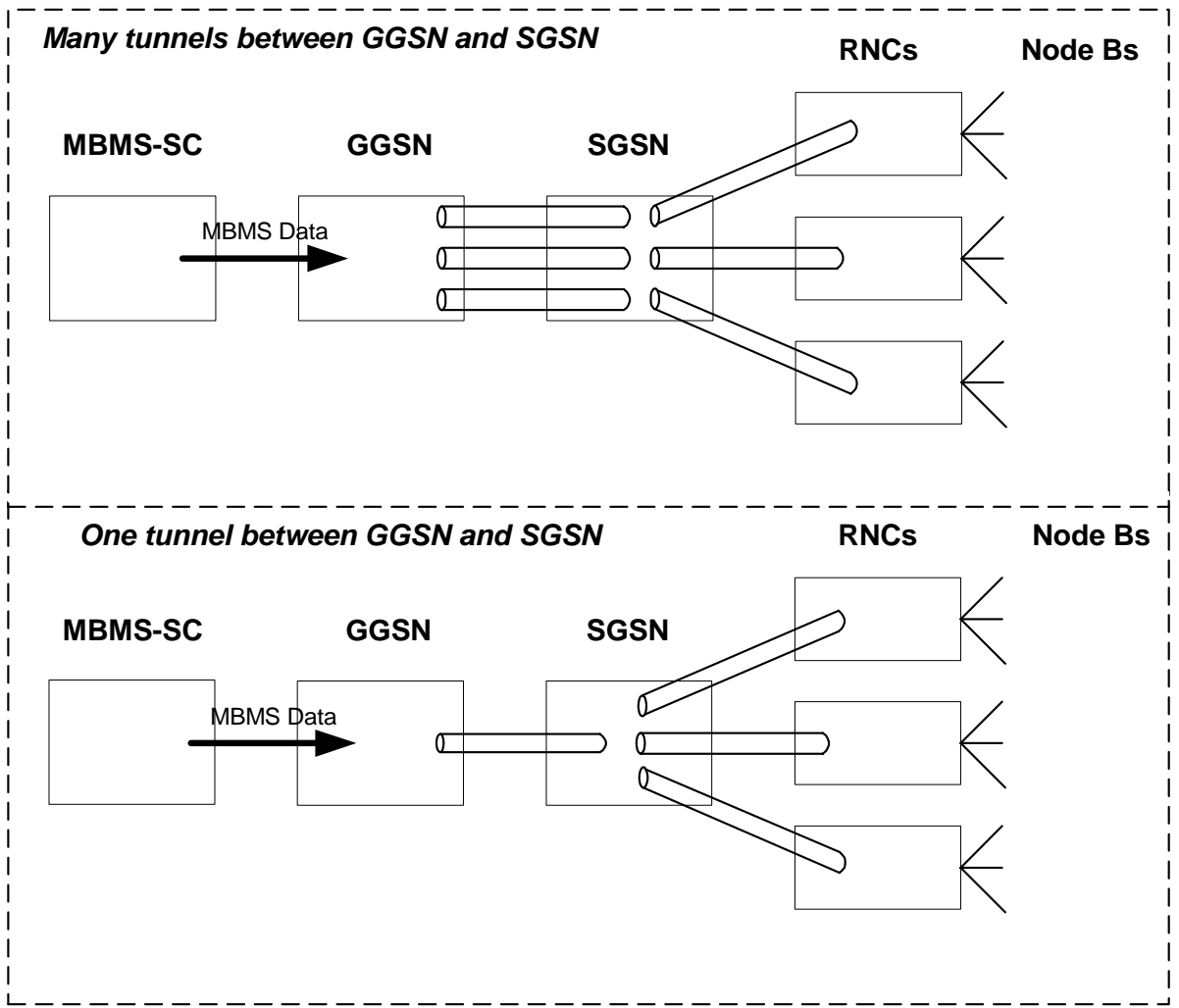

[Figure 78. Many tunnels between GGSN and SGSN vs. One tunnel between GGSN and SGSN.](#)

## Annex D

This section contains text for information

The following other options have been studied for Iu Flexibility:

1. Use of a Default SGSN
2. Bypassing SGSN
3. RNC initiates only required number of RABs

### Option 1: Default SGSN

1. As a result of activation or relocation, the RNC has to decide whether a multicast stream has to be established for that user or whether he can be added to an existing stream (this is assuming the network is using a point to multipoint link).
2. In order to ensure only one source of data to the RNC, the RNC has to have a known “default SGSN”, which it uses to establish a pre-configured path for the multicast stream.
3. A control RAB will be established between the RNC and the SGSN the user is registered in.
4. Volume based charging will be restricted.

In this option, SGSN 1 is the “default SGSN”. Only one RAB is established across the Iu interface.

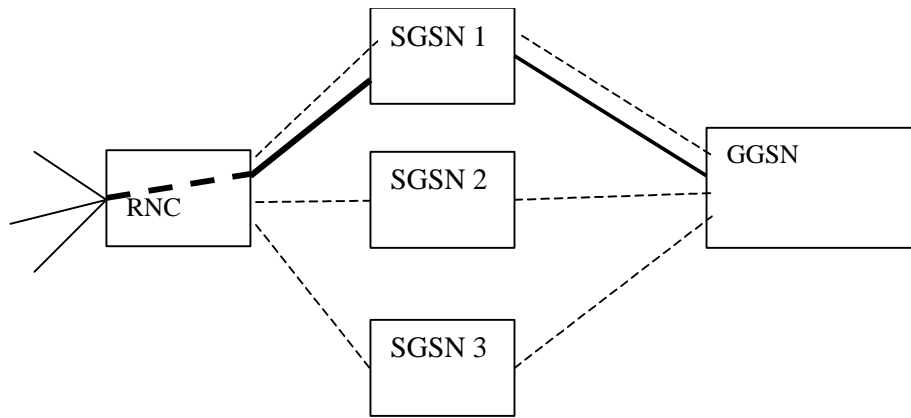

Figure 79.

### Option 2 “SGSN Bypass”:

This option would require GTP tunnel establishment and release for the user plane between the GGSN and RNC, without the SGSN being involved. Control plane information remains via the SGSN. Removing the SGSN from the data path would remove the inter-operator exposure available between SGSN and GGSN for roaming. Volume based charging would be restricted.

Signalling      - - - - -

Data path      ————

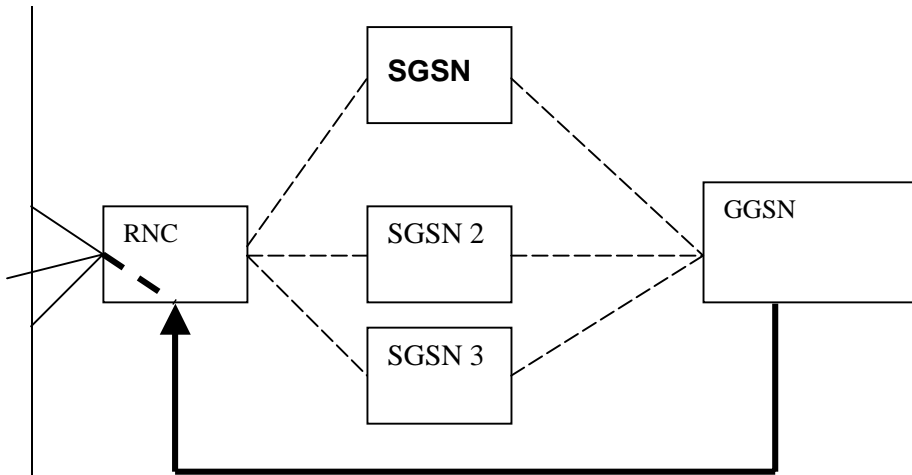

Figure 80.

Option 3 “RNC initiates only required number of RABs”

1 When the data transfer starts for an MBMS multicast the RNC detects that multiple SGSN send notifications to establish the same service. The RNC establishes the multicast RAB with only one SGSN. The other SGSNs establish no RABs for the MBMS multicast. But, the other SGSN receive the MBMS multicast data from the GGSN and generate volume charging information for the attached UEs.

2 If IU-Flex is employed, it is possible for users within a multicast group to be served by the same RNC but different SGSN. In this situation some of the MBMS IE must be the same even though different SGSNs may be involved.

It is FFS how this is done but the following solutions could be considered :

- a) These IE can be assigned by the same network element
- b) A consistent rule is applied unlike the random generation as used in the TMSI
- c) Synchronization between different SGSNs.

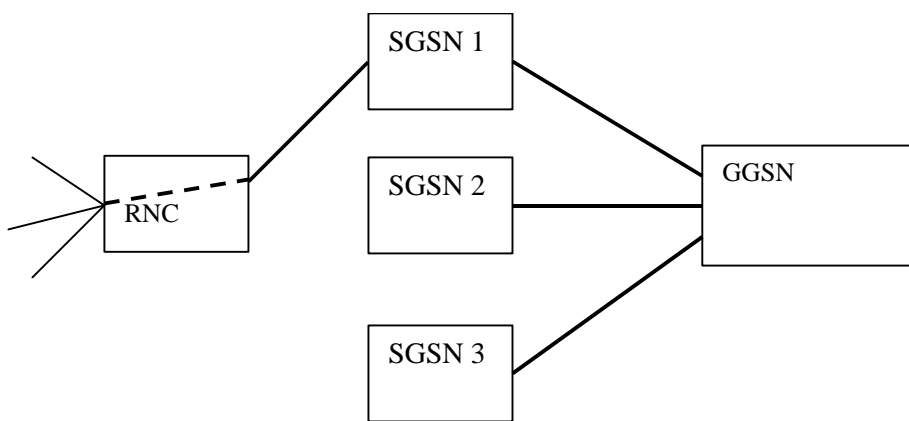

Figure 81.

|