

---

**Source:** SA5 (Telecom Management)  
**Title:** 2 Rel-4/5 CRs 32.200 (Service Charging): "Correction of interface descriptions"  
**Document for:** Approval  
**Agenda Item:** 7.5.3

---

Doc-1st-	Spec	CR	R	Phase	Subject	Cat	Version	Doc-2nd-	Workitem
SP-020740	32.200	015	-	Rel-4	Correction of interface descriptions	F	4.2.0	S5-024468	OAM-CH
SP-020740	32.200	016	-	Rel-5	Correction of interface descriptions	A	5.1.0	S5-024608	OAM-CH

CR-Form-v7

## CHANGE REQUEST

# 32.200 CR 015 # rev - # Current version: 4.2.0 #

For **HELP** on using this form, see bottom of this page or look at the pop-up text over the # symbols.

**Proposed change affects:** UICC apps#  ME  Radio Access Network  Core Network

<b>Title:</b>	# Correction of interface descriptions		
<b>Source:</b>	# SA5		
<b>Work item code:</b>	# OAM-CH	<b>Date:</b>	# 09/10/2002
<b>Category:</b>	# <b>F</b>	<b>Release:</b>	# Rel-4
	<i>Use one of the following categories:</i> <b>F</b> (correction) <b>A</b> (corresponds to a correction in an earlier release) <b>B</b> (addition of feature), <b>C</b> (functional modification of feature) <b>D</b> (editorial modification) Detailed explanations of the above categories can be found in 3GPP <a href="#">TR 21.900</a> .		<i>Use one of the following releases:</i> <b>2</b> (GSM Phase 2) <b>R96</b> (Release 1996) <b>R97</b> (Release 1997) <b>R98</b> (Release 1998) <b>R99</b> (Release 1999) <b>Rel-4</b> (Release 4) <b>Rel-5</b> (Release 5) <b>Rel-6</b> (Release 6)

<b>Reason for change:</b>	# The SSF and its interfaces are not in the charging architecture. The connection between the CS domain and the MMS R/S is currently missing in the charging architecture
<b>Summary of change:</b>	# Addition of the missing entities and interfaces listed above.
<b>Consequences if not approved:</b>	# The specification will contain incomplete charging logical architecture.

<b>Clauses affected:</b>	# 4.1		
<b>Other specs affected:</b>	#	#	Other core specifications # Test specifications # O&M Specifications # Rel-5 32.200
	#	#	
	#	#	
<b>Other comments:</b>	# Rel-5 Mirror CR in 32200CR016.		

## 4 Architecture

### 4.1 3G logical and charging logical architecture

Figure 2 shows the 3G logical architecture for Release 4 as described in TS 23.002 [21].

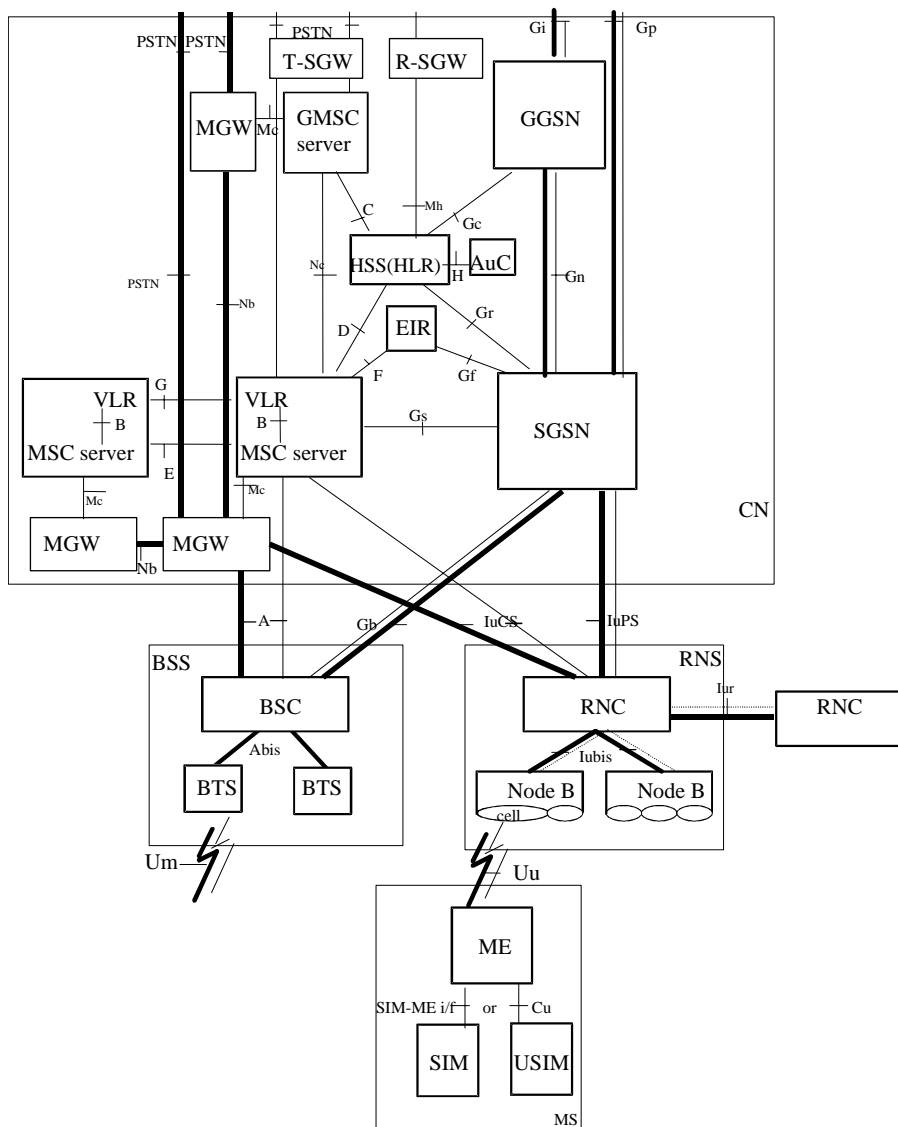

**Figure 2: Overview of the 3G Logical Architecture**

The 3<sup>rd</sup> Generation Mobile system is logically implemented on the GSM/GPRS structure through the addition of a new air interface supported by two network nodes, the RNC and the Node B. No inference should be drawn about the physical configuration on an interface from figure 2.

The CAMEL entities are not shown in figure 2. For the relationship ship of the CAMEL entities to the core network entities illustrated above, refer to TS 23.002 [21].

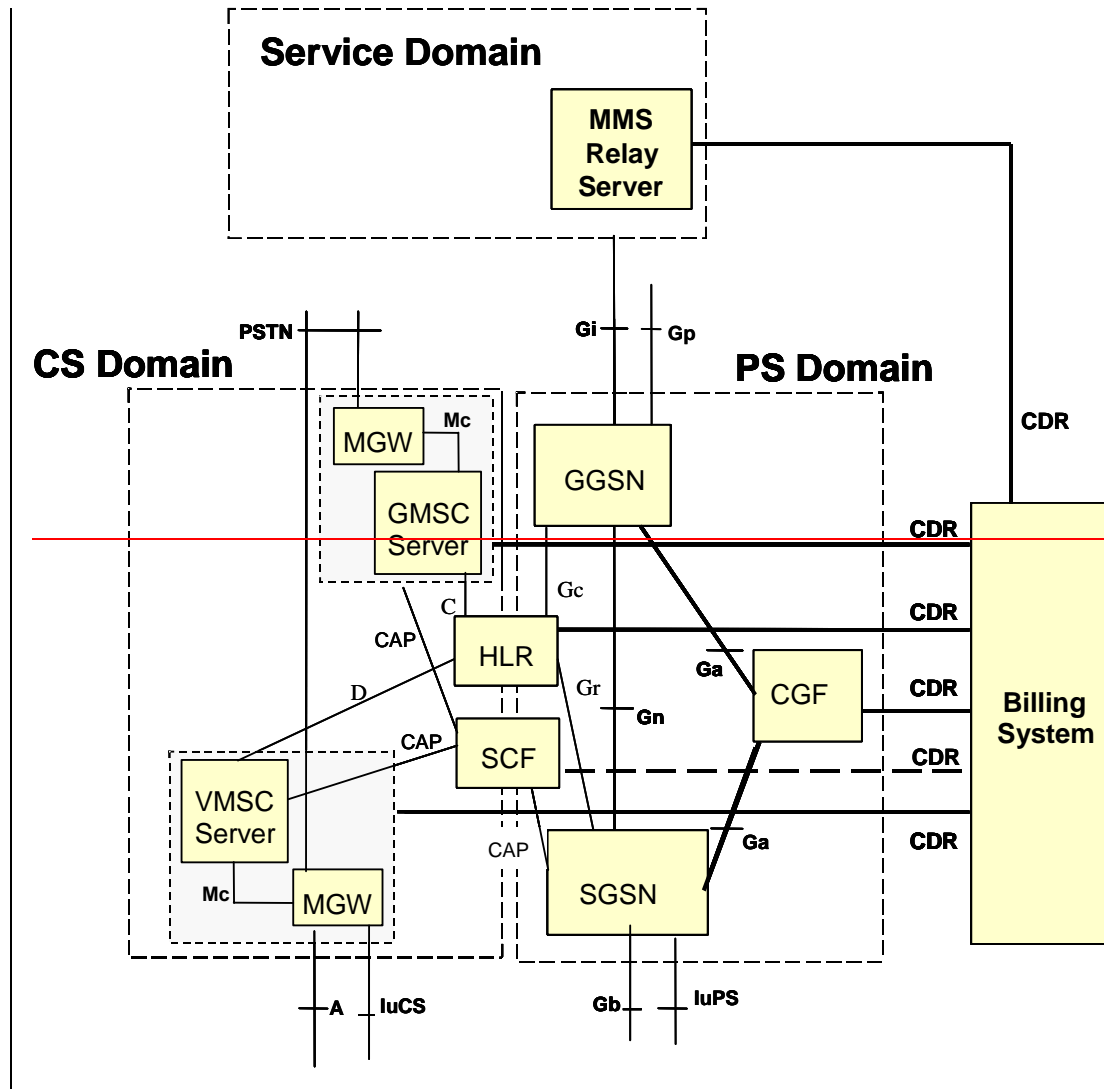

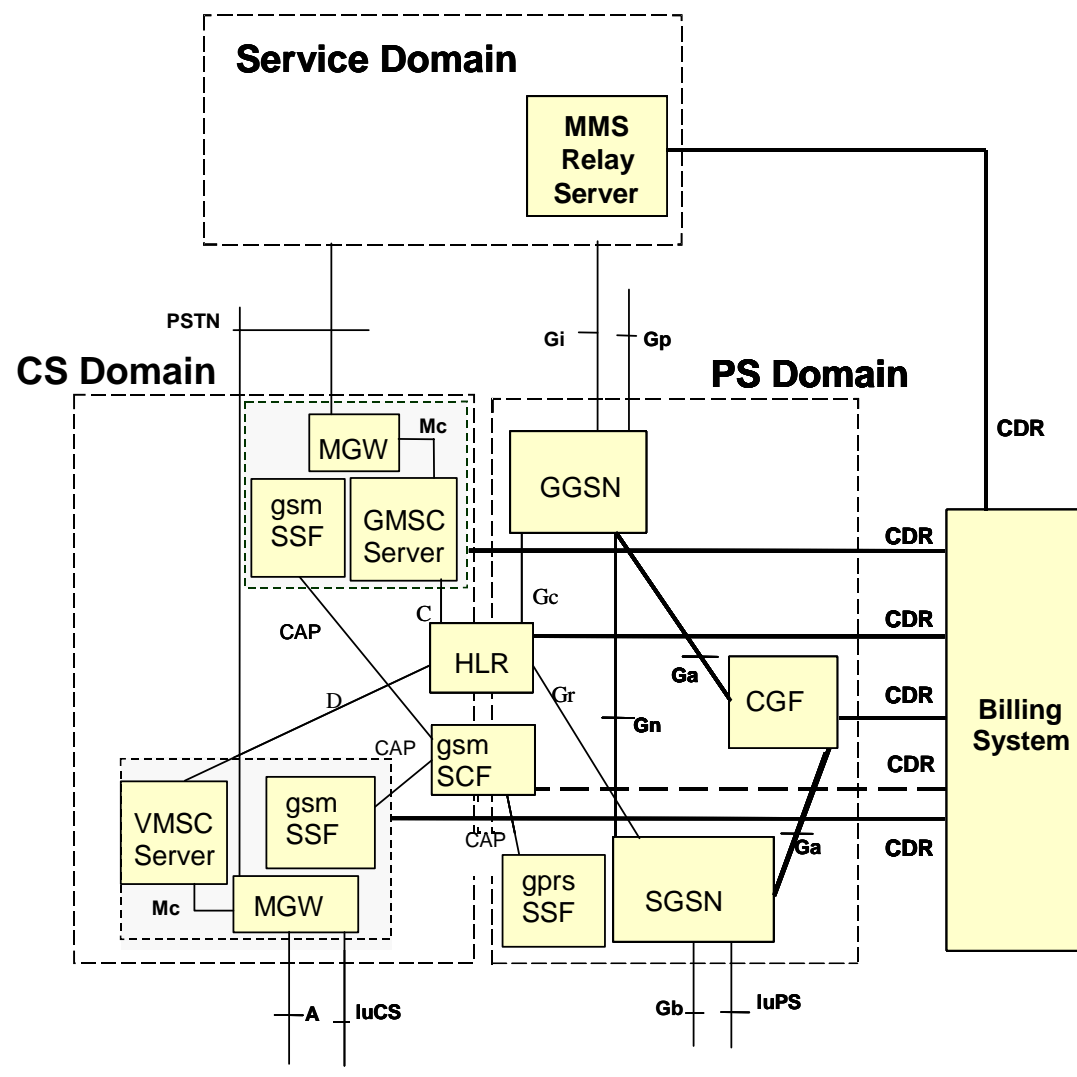

Figure 3: 3G charging logical architecture

Figure 3 illustrates the 3<sup>rd</sup> Generation charging logical architecture, which is subdivided by the two transmission planes, the Circuit Switched (CS) domain and the Packet Switched (PS) domain. The CDRs generated by the serving nodes (SGSN, GGSN) for the appropriate domain are forwarded via the Charging Gateway Function (CGF) entities to the Billing System for processing. Note that the SCF may also transfer CDRs directly to the Billing System. However, the current specifications do not include any CDR descriptions for the SCF. (While not shown explicitly in this figure, the VLR may also generate CDRs.) CDRs for the Multimedia Messaging Service (MMS) are delivered by the MMS Relay/Server when receiving or delivering multimedia messages to the MMS User Agent or to another Multimedia Messaging Service Environment (MMSE). CDRs from the MMS Relay/Server are transferred direct. The CGF has a significant role in the PS domain and is elaborated on in the subclause 4.2.

[The details of the connectivity from the CS/PS domain to the Service domain is out of scope for this document. For more information about possible implementations for MMS see TS 23.140 \[19\].](#)

CR-Form-v7
<b>CHANGE REQUEST</b>
⌘ <b>32.200 CR 016</b> ⌘ rev <b>-</b> ⌘ Current version: <b>5.1.0</b> ⌘

For **HELP** on using this form, see bottom of this page or look at the pop-up text over the ⌘ symbols.

**Proposed change affects:** UICC apps  ME  Radio Access Network  Core Network

<b>Title:</b>	⌘	Correction of interface descriptions
<b>Source:</b>	⌘	SA5
<b>Work item code:</b>	⌘	OAM-CH
		<b>Date:</b> ⌘ 22/12/2002
<b>Category:</b>	⌘	<b>A</b>
		Use <u>one</u> of the following categories: <i>F</i> (correction) <i>A</i> (corresponds to a correction in an earlier release) <i>B</i> (addition of feature), <i>C</i> (functional modification of feature) <i>D</i> (editorial modification) Detailed explanations of the above categories can be found in 3GPP <a href="#">TR 21.900</a> .
		<b>Release:</b> ⌘ Rel-5 Use <u>one</u> of the following releases: 2 (GSM Phase 2) R96 (Release 1996) R97 (Release 1997) R98 (Release 1998) R99 (Release 1999) Rel-4 (Release 4) Rel-5 (Release 5) Rel-6 (Release 6)

<b>Reason for change:</b>	⌘	The SSF and its interfaces are not in the charging architecture. The connection between the CS domain and the MMS R/S is currently missing in the charging architecture
<b>Summary of change:</b>	⌘	Addition of the missing entities and interfaces listed above.
<b>Consequences if not approved:</b>	⌘	The specification will contain incomplete charging logical architecture.

<b>Clauses affected:</b>	⌘	4.1				
<b>Other specs affected:</b>	⌘	<table border="1" style="display: inline-table; border-collapse: collapse;"> <tr> <td style="padding: 2px;">Y</td> <td style="padding: 2px;">N</td> </tr> <tr> <td style="text-align: center; padding: 2px;"><input type="checkbox"/></td> <td style="text-align: center; padding: 2px;"><input checked="" type="checkbox"/></td> </tr> </table> Other core specifications	Y	N	<input type="checkbox"/>	<input checked="" type="checkbox"/>
		Y	N			
		<input type="checkbox"/>	<input checked="" type="checkbox"/>			
<table border="1" style="display: inline-table; border-collapse: collapse;"> <tr> <td style="padding: 2px;">Y</td> <td style="padding: 2px;">N</td> </tr> <tr> <td style="text-align: center; padding: 2px;"><input type="checkbox"/></td> <td style="text-align: center; padding: 2px;"><input checked="" type="checkbox"/></td> </tr> </table> Test specifications	Y	N	<input type="checkbox"/>	<input checked="" type="checkbox"/>		
Y	N					
<input type="checkbox"/>	<input checked="" type="checkbox"/>					
<table border="1" style="display: inline-table; border-collapse: collapse;"> <tr> <td style="padding: 2px;">Y</td> <td style="padding: 2px;">N</td> </tr> <tr> <td style="text-align: center; padding: 2px;"><input type="checkbox"/></td> <td style="text-align: center; padding: 2px;"><input checked="" type="checkbox"/></td> </tr> </table> O&M Specifications	Y	N	<input type="checkbox"/>	<input checked="" type="checkbox"/>		
Y	N					
<input type="checkbox"/>	<input checked="" type="checkbox"/>					
<b>Other comments:</b>	⌘	Mirror CR of 32200CR015.				

# 4 Architecture

## 4.1 3G logical and charging logical architecture

Figure 2 shows the 3G logical architecture for Release 4 as described in TS 23.002 [21].

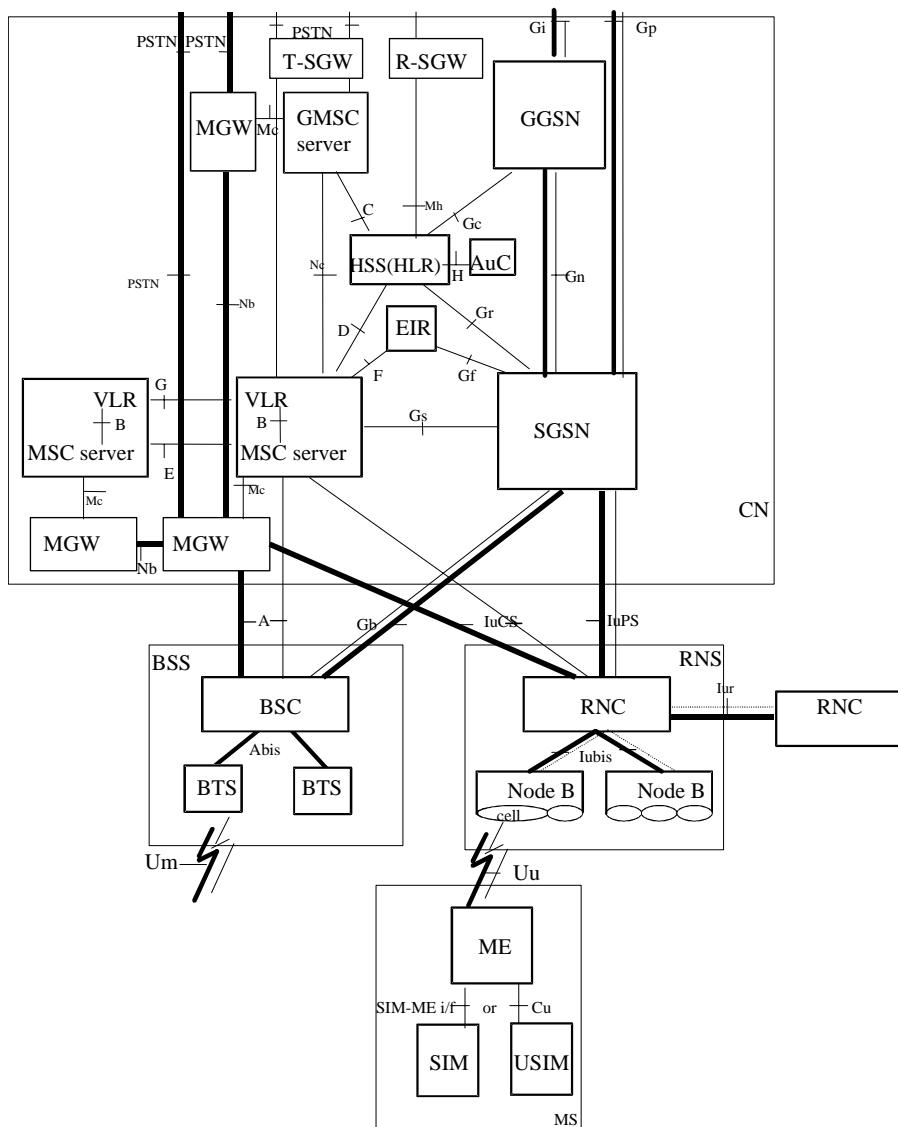

**Figure 2: Overview of the 3G Logical Architecture**

The 3<sup>rd</sup> Generation Mobile system is logically implemented on the GSM/GPRS structure through the addition of a new air interface supported by two network nodes, the RNC and the Node B. No inference should be drawn about the physical configuration on an interface from figure 2.

The CAMEL entities are not shown in figure 2. For the relationship ship of the CAMEL entities to the core network entities illustrated above, refer to TS 23.002 [21].

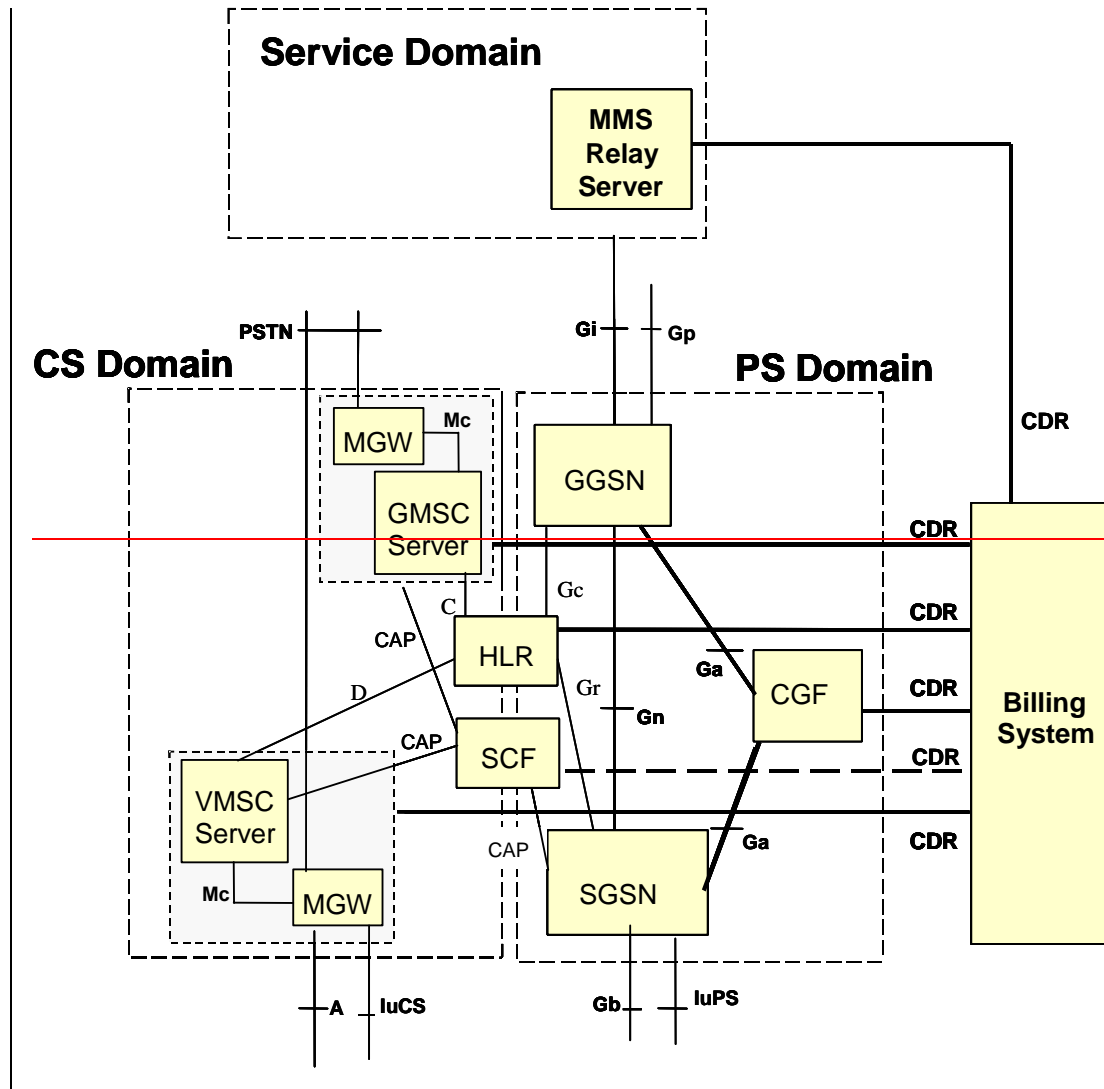



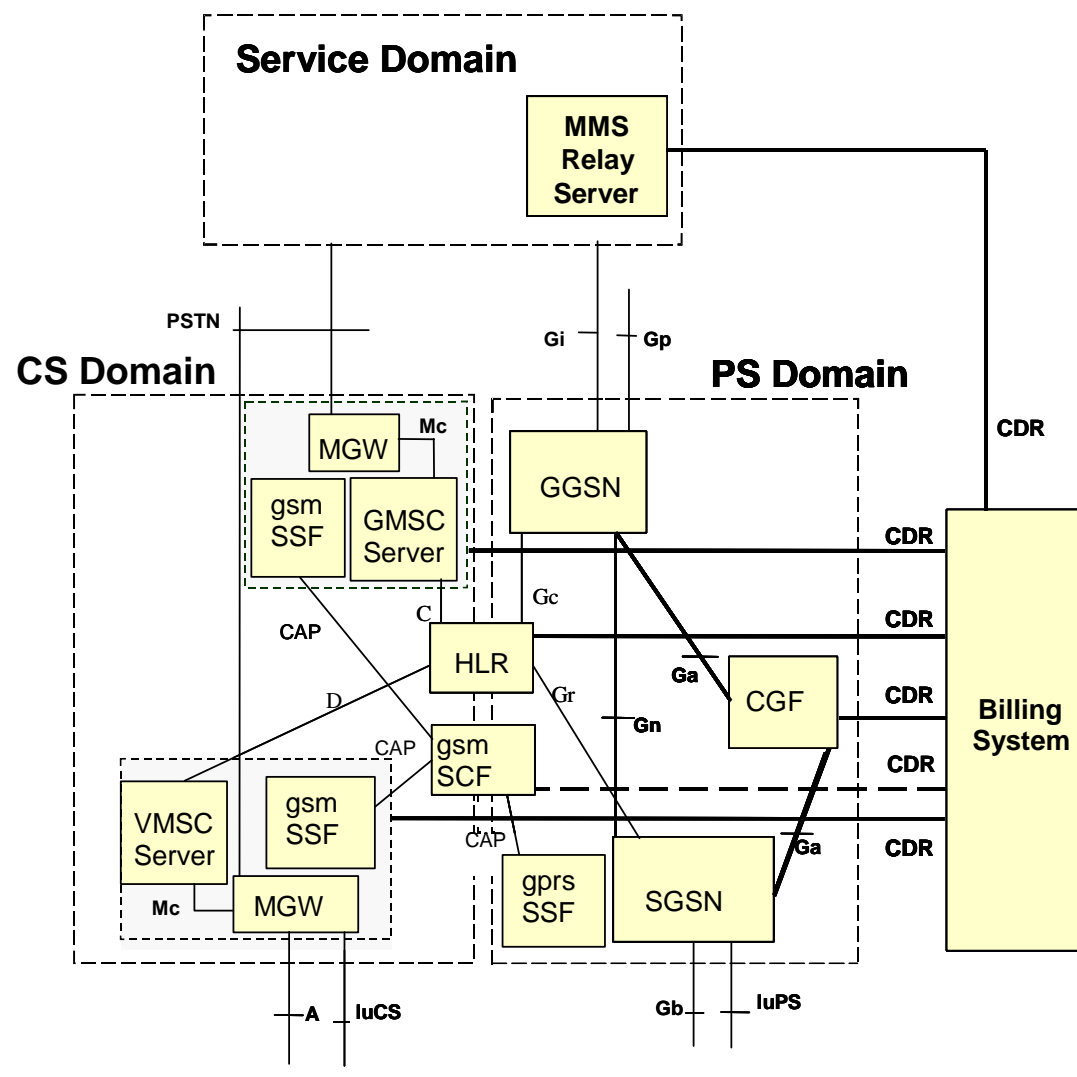

**Figure 3: 3G charging logical architecture**

Figure 3 illustrates the 3<sup>rd</sup> Generation charging logical architecture, which is subdivided by the two transmission planes, the Circuit Switched (CS) domain and the Packet Switched (PS) domain. The CDRs generated by the serving nodes (SGSN, GGSN) for the appropriate domain are forwarded via the Charging Gateway Function (CGF) entities to the Billing System for processing. Note that the SCF may also transfer CDRs directly to the Billing System. However, the current specifications do not include any CDR descriptions for the SCF. (While not shown explicitly in this figure, the VLR may also generate CDRs.) CDRs for the Multimedia Messaging Service (MMS) are delivered by the MMS Relay/Server when receiving or delivering multimedia messages to the MMS User Agent or to another Multimedia Messaging Service Environment (MMSE). CDRs from the MMS Relay/Server are transferred direct. The CGF has a significant role in the PS domain and is elaborated on in the subclause 4.2.

[The details of the connectivity from the CS/PS domain to the Service domain is out of scope for this document. For more information about possible implementations for MMS see TS 23.140 \[19\].](#)