

**Source:** TruePosition  
**Title:** Uplink TDOA location method in UMTS networks  
**Document for:** DISCUSSION

---

The marketplace in the United States has shown that the Uplink TDOA location method is a feasible location method for IS-136 TDMA networks. Uplink TDOA also has proven to be highly accurate for location of wireless subscribers in CDMA based systems. Additionally, uplink TDOA may have application to UMTS networks and is something that the SA needs to be informed about.

A recent proposal in the 3GPP TSG RAN Plenary meeting to explore the feasibility of uplink TDOA for UMTS networks was rejected.

With the goal of demonstrating the feasibility of uplink TDOA location method for UMTS networks, TruePosition would like to inform the TSG SA about this location method and get advice regarding the procedure required to standardize uplink TDOA for UMTS networks.

# A PROPOSAL TO ADD UPLINK TDOA TO THE UTRAN

## Abstract

The Uplink TDOA methodology has proven to be highly accurate for location of wireless subscribers in CDMA based systems. The wide bandwidth coupled with significant processing gain available in Network Based location systems provide a high level of accuracy in environments where other techniques are not appropriate. This gain in accuracy and simplicity has less overall complexity than equivalent implementations of Downlink OTDOA and A-GPS. The Uplink TDOA method also provides significant flexibility for implementation of future Location Service enhancements.

This document discusses these advantages and describes the functionality to be added to the Stage 2 Functional Specification of UE Positioning in UTRAN (TS 25.305) that is required to include Uplink TDOA. Similar modifications will be proposed to the Stage 2 LCS Architecture for UTRAN documents (23.271 and others).

## Advantages of Uplink TDOA in the UTRAN environment

TruePosition has spent over nine years investigating potential location technologies and has selected Uplink TDOA as the method that supplies the best performance in the widest possible set of circumstances, at the lowest overall complexity and with the least impact on the wireless infrastructure. The following list summarizes the features that make Uplink TDOA the technique of choice:

- The primary difference between Uplink TDOA and Downlink OTDOA is the processing capacity available to analyze signal information and calculate subscriber locations. Handsets have a limited amount of processing power to apply to location determination. Network based location systems combine the DSP power from many LMUs for the location of a single mobile station and, as a result, are capable of significantly more processing applied over much longer periods of time. This increased processing power provides:
  - 20 to 30 dB greater processing gain than a DL-OTDOA solution through very long integration times. In the DL-OTDOA system, the MS must make measurements of pilot signals from several sites, one by one, while still providing the other MS functions, the DSP processors of many LMUs work simultaneously to locate a single MS.
  - Sophisticated multipath mitigation techniques
  - Simultaneous location of many subscriber units
  - Acquisition of location information from many more distant location receivers (LMU)
- For User Equipment in the Cell\_DCH state, there is no additional interference contribution for location determination. The Uplink TDOA technique locates the UE using the energy associated with the existing bearer and control information, when the signal is transmitted at the normal power level. No power-up is needed, due to the long integration time.
- For User Equipment in the idle mode, there is no more contribution to interference than normal subscriber traffic and for a much shorter period of time (100-500 mSec), which is

comparable to the amount of data transferred in the assistance and measurement data. Additionally, the interference contribution is relatively low for Uplink TDOA using control channel activity because of the relatively large spreading factors associated with the Signaling Radio Bearers (SRB).

- There are techniques that could further limit the interference contribution associated with the location of idle mobile. These functionalities could also be used as a trade for QoS accuracy requirements versus interference contribution.
- The Uplink TDOA methodology requires no modification to the Node B or User Equipment, based on current specifications.
- Extensive testing of Uplink TDOA in New York City, New York, USA (Manhattan) has demonstrated that it is superior to A-GPS in environments with limited visibility of the GPS satellites and, more importantly, the high levels of RF attenuation prevalent in urban environments, and building interiors.
- Uplink TDOA is based upon the solution for IS-95 CDMA, which has been tested in rural, suburban, and urban environments, with a demonstrated accuracy of 50m-70m (67%, see table below). A downlink OTDOA solution for CDMA has not demonstrated this level of accuracy. The solution proposed for WCDMA has the advantage of wider bandwidth, which is expected to reduce location errors by 30%.
- Uplink TDOA provides protection against obsolescence. It is far easier and less complex to upgrade the software in RNCs and LMUs than it is to upgrade millions of UEs.
- Additional benefits:
  - Uplink TDOA does not require implementation of the Idle Period, Down-Link (IPDL) functionality. IPDL prevents communication in the DL while allowing the MS to make timing measurements spanning only 256-1025 chips.
  - Uplink TDOA can operate in FDD and TDD networks.
  - The Uplink TDOA solution, when integrated with the Node B will have a very low incremental cost.

## The Uplink TDOA Approach for CDMA in UTRAN

TruePosition proposes to enhance the UTRAN Location Services as defined in TS 25.305 to include an Uplink TDOA capability by expanding the definition and functionality of the SMLC.

The following diagram illustrates the proposed topology:

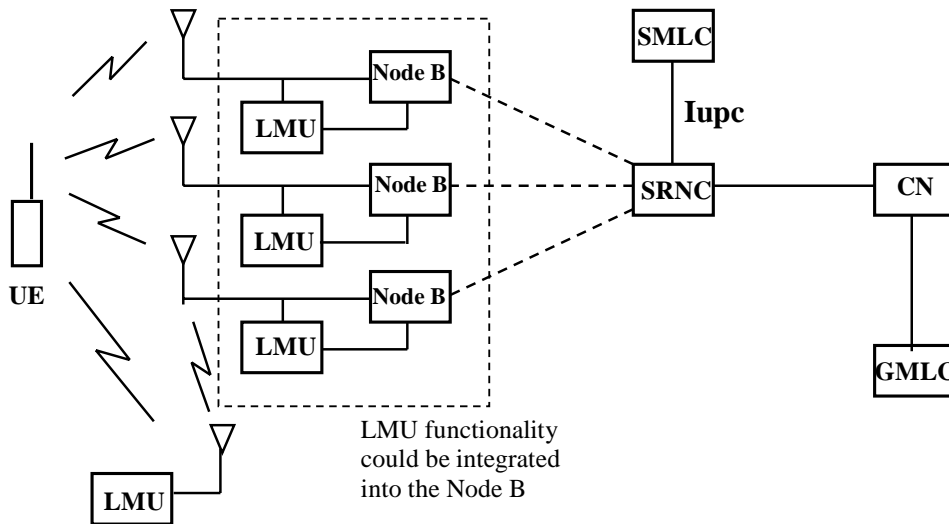

The general procedures associated with UE location using Uplink TDOA are:

- The RNC receives a LOCATION\_REQUEST message from the GMLC via the CN
- The RNC establishes whether the requested UE is in the idle mode or Cell\_DCH state
  - If the UE is in the Cell\_DCH state, Node B identity, scrambling code and all other information necessary to identify the UE's RF energy are passed to the SMLC
  - If the UE is in idle mode, the RNC will cause the UE to transmit for a fixed period of time and pass the Node B identity, scrambling code and all other information necessary to identify the UE's RF energy for that transmission to the SMLC.
- The SMLC will task the Primary LMU (typically associated with the UE's current Node B) with capturing and possibly demodulating a defined amount of the target UE's transmission. The SMLC will also task the Secondary LMUs (those LMU that have the potential to receive the transmission) with capturing the target UE's transmission.
- The Primary and Secondary LMU will time stamp this data and return it to the SMLC
- The SMLC will inform the RNC that, in the case of idle mobile location, the UE can stop transmitting
- The RNC will inform the UE to stop transmitting and resume idle mode activity
- The SMLC will use the information from the Primary and Secondary LMU's to perform a TDOA calculation of the UE location
- The UE location will be provided to the GMLC for distribution to the client application.

The following section of this document provides a high level description of the changes that are required to implement Uplink TDOA into the UTRAN:

- Include Uplink TDOA functionality in the SMLC and expand the Iupc protocol to include the required TDOA messaging
- Modify RNC functionality to provide the information to the SMLC which will identify the time and coding of a particular subscriber's (UE) RF energy (Cell\_DCH state)
- Modify the RNC to turn target UE on, transmit information and turn the target UE off when informed to do so by the SMLC (idle mode)
  - This may also include, initially, transmission for fixed periods of time but may be eventually enhanced to include variable transmission periods
  - Protection mechanisms must be included to avoid prolonged UE transmission
  - Generically, a dedicated channel could be assigned by the RNC. A combination of the time this channel is assigned, and the target  $E_b/N_0$ , will control the amount of energy transmitted by the MS. The total energy (combination of the number of bits and target requested  $E_b/N_0$ ) should be provided to the RNC by the SMLC. The amount of energy requested should be a function of the QoS required for the position. The RNC will assign the appropriate dedicated channel, and control the target  $E_b/N_0$  to obtain the appropriate energy, per the constraints of the system capacity, and the request of the SMLC. The RNC should report the effective data rate and  $E_b/N_0$  for the given time period.
- Modify the RNC to transparently transport LMU to SMLC signaling traffic
  - The previously defined LMU LCS Protocol (LLP) as defined in ETSI TS 101 725 (GSM 04.71) may be a candidate to provide the basis for this functionality

#### Solution of the CDMA "Near-Far" problem

As has been widely discussed, there are challenges in using Uplink TDOA location systems in the CDMA environment when the subscriber equipment (UE) is in close proximity to the serving Node B; i.e., the "near-far" problem. However, there are techniques that enable reasonably accurate Uplink TDOA location determination even when the subscriber equipment is transmitting with very little power. The following presentation will define the dimension of this problem and then solutions will be discussed.

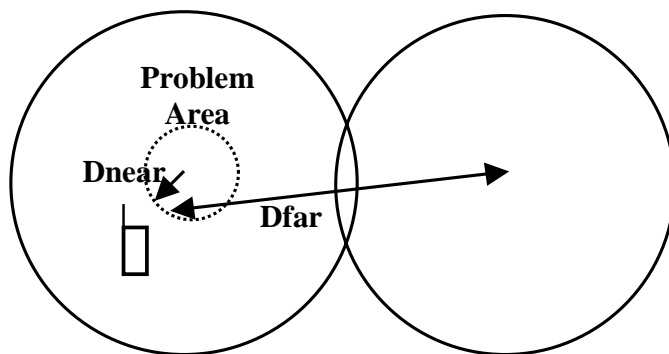

**Dnear** is the distance from the MS to the serving Node B antenna. **Dfar** is the distance from the MS to a distant Node B antenna. The near/far ratio is the ratio of **Dfar:Dnear** at which a distant Node B is a distance of Dfar from the MS and can **just** detect the signal from the MS. This ratio is a function of the propagation environment, MS transmit power and the processing gain from integration time.

The Uplink TDOA solution will use integration times covering up to 10,000 user data bits to maximize the near/far ratio. At a spreading ratio of 256, an integration over 2.5 million chips will be computed, compared to the 256-1024 chip integration as suggested for DL-OTDOA. This long integration time, made possible by the powerful DSPs in the LMUs, will allow any Node B site, which is cooperating in the location solution, to detect this signal at a level which is 40 dB below the level received by the serving Node B.

Assuming a suburban propagation law, where the signal attenuation is proportional to  $1/r^{3.5}$ , a near/far ratio of 14 is achieved. Therefore, as long as the MS is more than 1/14 of the distance of the cell site spacing from the serving Node B, some surrounding Node B sites can detect the MS. This is equivalent to 1/7 of the cell site radius, and hence 1/49 or about 2 % of the cell site area. Therefore the near/far problem only affects the inner 2% of the coverage area.

For example, if in a suburban environment where cell site spacing is 3 km, any mobile that cannot be detected by the adjacent sites must be within 512 m of the serving site. The use of round trip delay measurements have been demonstrated in IS-95 to provide to provide range accuracy of 100 m, while power measurements across multiple sectors has demonstrated a direction measurement with an accuracy of 30 degrees. These combined techniques are expected to provide an accuracy of 162 m in this near region, which is only 2% of the coverage area, while the accuracy is much better over the remaining 98 % of the coverage area where normal Uplink TDOA techniques are applied. More sophisticated Angle Of Arrival (AOA) techniques will significantly improve these numbers.

The table below shows the results of this analysis in urban, suburban and rural scenarios.

Environment	Cell Site Spacing (m)	Power law	Near/far ratio	Expected Accuracy in the near region (m)	Near Percentage (cell area)
Urban	1000	4.0	10	75	4.00
Suburban	3000	3.5	14	160	2.07
Rural	15000	3.0	22	250	0.86

Note that even in the rural environment, where the cell site spacing is very large, excellent accuracy is achieved over 99 % of the coverage area.

In the implemented IS-95 solution, which locates a MS using the Access Channel signal, the integration spans only 576 data bits. However, these Access Channel signals are typically transmitted at power level 8 dB higher than traffic channel signals, yielding an effective 3634 user data bits. The MS is located using only the energy already transmitted on the Access Channel, at the power level normally used on the Access Channel. No additional energy is need, and hence no additional interference is created. Traffic channel location has also been

demonstrated in IS-95 systems, again computed only using the energy already transmitted by the MS for voice communication, at the normal power level, creating no additional interference.

For WCDMA, the use of 3000 or more bits is expected to provide accuracy superior to that demonstrated in IS-95 CDMA systems, because the increased bandwidth of the signal.

### Uplink TDOA Performance and Test Results

A test bed system with over 170 sites has been implemented on major North American carrier's systems. These include dense urban (Manhattan Island, New York, New York, USA), suburban, rural and open water environments. Hundreds of thousands of location events over an area of several thousand square kilometers have been analyzed and used to continuously improve system performance.

The following table summarizes the results of this testing for IS-95 CDMA in an urban, suburban and rural environment. Test calls were made from many scenarios including indoor, out-door pedestrian, in-vehicle stationary, and in-vehicle moving at various speeds. Calls were placed at various distances from the serving cell site to characterize the effect of the near far problem. Our calculations indicate that the wider bandwidth associated with W-CDMA will provide a location accuracy improvement of 30% over the performance achieved in IS-95.

Environment	67%	95%
Urban	70m	153m
Suburban	62.5m	183m
Rural	49m	275m

### Uplink TDOA Location Capacity

Uplink TDOA locations supports a high location rate for active calls, while having no impact on overall system capacity, as the energy already transmitted by the UE can be used for location.

For idle mobiles, a single location consumes the equivalent air interface capacity of 1 full rate voice circuit for 150 milliseconds, on average. Assuming a high location rate of 1 per second per 5MHz carrier, 1 Mb/s total cell throughput and an average value of 3000 user bits for location purposes, this amounts to a 0.30 % consumption of system capacity.