

# 3GPP TS 33.203 V1.0.0 (2001-12)

---

*Technical Specification*

**3rd Generation Partnership Project;  
Technical Specification Group SA3;  
Access security for IP-based services  
(Release 5)**

---



The present document has been developed within the 3<sup>rd</sup> Generation Partnership Project (3GPP™) and may be further elaborated for the purposes of 3GPP.

The present document has not been subject to any approval process by the 3GPP Organisational Partners and shall not be implemented. This Specification is provided for future development work within 3GPP only. The Organisational Partners accept no liability for any use of this Specification. Specifications and reports for implementation of the 3GPP™ system should be obtained via the 3GPP Organisational Partners' Publications Offices.

---

Keywords

---

Access security, IP Multimedia, SIP

**3GPP**

Postal address

---

3GPP support office address

---

650 Route des Lucioles - Sophia Antipolis  
Valbonne - FRANCE  
Tel.: +33 4 92 94 42 00 Fax: +33 4 93 65 47 16

Internet

---

<http://www.3gpp.org>

---

**Copyright Notification**

---

No part may be reproduced except as authorized by written permission.  
The copyright and the foregoing restriction extend to reproduction in all media.

© 2000, 3GPP Organizational Partners (ARIB, CWTS, ETSI, T1, TTA, TTC).  
All rights reserved.

# Contents

Foreword.....	5
1 Scope .....	6
2 References .....	6
3 Definitions, symbols and abbreviations.....	7
3.1 Definitions.....	7
3.3 Abbreviations .....	7
4 Overview of the security architecture.....	7
5 Security features .....	10
5.1 Secure access to IMS .....	10
5.1.1 Authentication of the subscriber and the network .....	10
5.1.2 Re-Authentication of the subscriber .....	11
5.1.3 Confidentiality protection.....	11
5.1.4 Integrity protection .....	11
5.2 Network topology hiding .....	12
6 Security mechanisms .....	12
6.1 Authentication and key agreement.....	12
6.1.1 Registration of an IM-subscriber .....	13
6.1.2 Authentication failures .....	15
6.1.2.1 User authentication failure.....	16
6.1.2.2 Network authentication failure .....	16
6.1.4 Synchronization failure .....	17
6.2 Confidentiality mechanisms .....	18
6.3 Integrity mechanisms .....	19
6.4 Hiding mechanisms .....	19
7 Security association set-up procedure .....	19
7.1 Security association parameters .....	19
7.2 Set-up of security associations (successful case) .....	20
7.3 Error cases in the set-up of security associations .....	21
7.3.1 Error cases related to IMS AKA.....	21
7.3.1.1 User authentication failure.....	21
7.3.1.2 Network authentication failure .....	22
7.3.1.3 Synchronisation failure.....	22
7.3.2 Error cases related to the Security-Set-up.....	22
7.3.2.1 Unacceptable proposal set .....	22
7.3.2.2 Unacceptable algorithm choice .....	22
7.3.2.3 Failed consistency check of Security-Set-up lines .....	22
7.3.3 Authenticated re-registration .....	23
7.3.3.1 Handling of security associations in authenticated re-registrations (successful case) .....	23
7.3.3.2 Error cases related to authenticated re-registration.....	24
7.3.3.3 Error cases related to IMS AKA.....	24
7.3.3.4 Error cases related to the Security-Setup.....	24
8 ISIM.....	25
<b>Annex &lt;A&gt; (normative): &lt;Normative annex title&gt;.....</b>	<b>27</b>
<b>Annex B (Informative): Mechanisms for IPSec based solution .....</b>	<b>28</b>
B.1 6.2 Confidentiality mechanisms .....	28
B.2 6.3 Integrity mechanisms .....	28
<b>Annex C (Informative): Mechanisms for SIP-level solution .....</b>	<b>29</b>
C.1 6.2 Confidentiality mechanisms .....	29
C.2 6.3 Integrity mechanisms .....	29

**Annex D (Informative): Set-up procedures for IPSec based solution ..... 32**  
D.1 Security association parameters .....32  
D.2 Security mode setup for IPsec ESP .....33  
D.2.1 General procedures specific to the ESP protection mechanism.....33  
D.2.2 Handling of user authentication failure .....33  
D.2.3 Authenticated re-registration procedures specific to the ESP protection mechanism.....33

**Annex E (Informative): Set-up procedures for SIP level based solution..... 34**

**Annex F (Informative): Open issues in SA3 tailored to CN1..... 35**

**Annex X (informative): Change history ..... 37**

---

# Foreword

This Technical Specification has been produced by the 3<sup>rd</sup> Generation Partnership Project (3GPP).

The contents of the present document are subject to continuing work within the TSG and may change following formal TSG approval. Should the TSG modify the contents of the present document, it will be re-released by the TSG with an identifying change of release date and an increase in version number as follows:

Version x.y.z

where:

- x the first digit:
  - 1 presented to TSG for information;
  - 2 presented to TSG for approval;
  - 3 or greater indicates TSG approved document under change control.
- y the second digit is incremented for all changes of substance, i.e. technical enhancements, corrections, updates, etc.
- z the third digit is incremented when editorial only changes have been incorporated in the document.

---

# 1 Scope

The scope for this technical specification is to specify the security features and mechanisms for secure access to the IM subsystem (IMS) for the 3G mobile telecommunication system.

The IMS in UMTS will support IP Multimedia applications such as video, audio and multimedia conferences. 3GPP has chosen SIP, Session Initiation Protocol, as the signaling protocol for creating and terminating Multimedia sessions, cf. TS 33.102 [6]. This specification only deals with how the SIP signaling is protected, how the subscriber is authenticated and how the subscriber authenticates the IMS.

---

# 2 References

The following documents contain provisions which, through reference in this text, constitute provisions of the present document.

- [1] 3GPP TS 33.102: "3rd Generation Partnership Project; Technical Specification Group Services and System Aspects; 3G Security; Security Architecture".
- [2] 3GPP TS 23.228: "3rd Generation Partnership Project; Technical Specification Group Services and System Aspects; IP multimedia subsystem; Stage 1".
- [3] 3GPP TS 23.228: "3rd Generation Partnership Project; Technical Specification Group Services and System Aspects; IP Multimedia Subsystem (IMS); Stage 2".
- [4] 3GPP TS 21.133: "3rd Generation Partnership Project; Technical Specification Group Services and System Aspects; 3G Security; Security Threats and Requirements".
- [5] 3GPP TS 33.210: "3rd Generation Partnership Project; Technical Specification Group Services and System Aspects; 3G Security; Network Domain Security; IP network layer security".
- [6] IETF RFC 2543bis-04 (2001): "SIP: Session Initiation Protocol".
- [7] IETF RFC 2284 (1998): "PPP Extensible Authentication Protocol (EAP)".
- [8] IETF Draft (2001): "draft-arkko-pppext-eap-aka-01.txt".
- [9] IETF Draft (2001): "draft-torvinen-http-eap-01.txt".
- [10] IETF RFC 2716 (1999): "PPP EAP TLS Authentication Protocol".
- [11] IETF Draft (2001): "draft-haverinen-pppext-eap-sim-01.txt".
- [12] 3GPP TS 21.905: "3rd Generation Partnership Project; Technical Specification Group Services and System Aspects; Vocabulary for 3GPP Specifications".
- [13] 3GPP TS 24.229: "3rd Generation Partnership Project; Technical Specification Group (TSG) Core Network; IP Multimedia Call Control Protocol based on SIP and SDP; stage 3".
- [14] 3GPP TS 23.002: "3rd Generation Partnership Project; Technical Specification Group Services and Systems Aspects; Network architecture".
- [15] 3GPP TS 23.060: "3rd Generation Partnership Project; Technical Specification Group Services and System Aspects; General Packet Radio Service (GPRS); Service description; Stage 2".

---

## 3 Definitions, symbols and abbreviations

### 3.1 Definitions

For the purposes of the present document, the following terms and definitions apply.

**Confidentiality:** The property that information is not made available or disclosed to unauthorised individuals, entities or processes.

**Data integrity:** The property that data has not been altered in an unauthorised manner.

**Data origin authentication:** The corroboration that the source of data received is as claimed.

**Entity authentication:** The provision of assurance of the claimed identity of an entity.

**Key freshness:** A key is fresh if it can be guaranteed to be new, as opposed to an old key being reused through actions of either an adversary or authorised party.

**USIM – User Services Identity Module.** In a security context, this module is responsible for performing UMTS subscriber and network authentication and key agreement. It should also be capable of performing GSM authentication and key agreement to enable the subscriber to roam easily into a GSM Radio Access Network.

**ISIM – IM Services Identity Module.** In a security context, this module is responsible for performing subscriber and network authentication and key agreement in IMS. The ISIM resides on the UICC.

### 3.3 Abbreviations

For the purposes of the present document, the following abbreviations apply. TS 21.905 [12] contains additional applicable abbreviations:

AAA	Authentication Authorisation Accounting
AKA	Authentication and key agreement
CSCF	Call Session Control Function
HSS	Home Subscriber Server
IM	IP Multimedia
IMPI	IM Private Identity
IMPU	IM Public Identity
IMS	IP Multimedia Core Network Subsystem
ISIM	IM Services Identity Module
MAC	Message Authentication Code
ME	Mobile Equipment
SA	Security Association
SEG	Security Gateway
SDP	Session Description Protocol
SIP	Session Initiation Protocol
UA	User Agent

---

## 4 Overview of the security architecture

In the PS domain, the service is not provided until a security association is established between the mobile equipment and the network. IMS is essentially an overlay to the PS-Domain and has a low dependency of the PS-domain. Consequently a separate security association is required between the multimedia client and the IMS before access is granted to multimedia services. The IMS Security Architecture is shown in the following figure. The ISIM is responsible for the handling of keys, SQN etc that are tailored to IMS. The security parameters handled by the ISIM are independent of the similar security parameters that exist in the USIM.

Although ISIM and USIM are logically independent, all the following cases are possible for implementation:

- ISIM and USIM are implemented as a single application inside one UICC

- ISIM and USIM are implemented as two distinct applications inside one UICC
- ISIM and USIM are implemented inside two distinct UICCs.

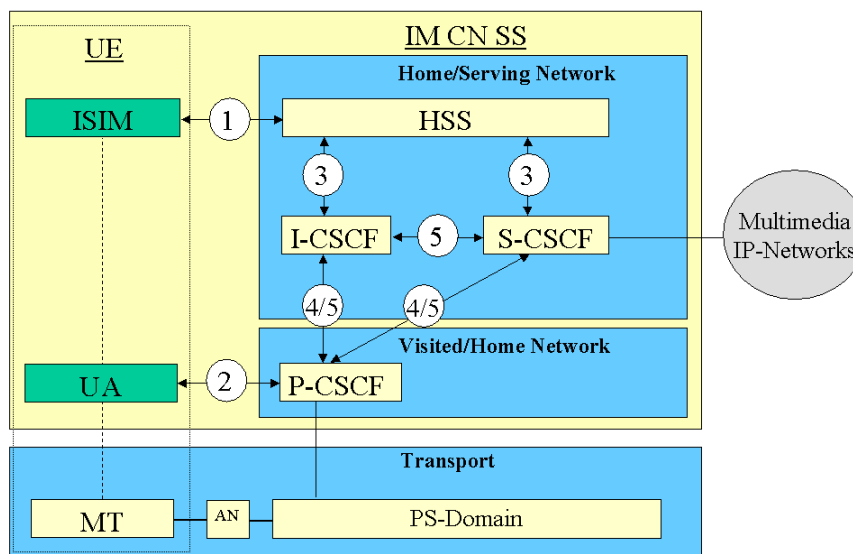

**Figure 1: The IMS security architecture**

[Editors Note: This figure indicates that the UA i.e. session control resides in the TE. This should be updated when the work on the TR on Service Requirements for UE Functionality Split for Release 5 is stable.]

There are five different security associations and different needs for security protection for IMS and they are numbered 1,2, 3, 4 and 5 in figure 1, where:

1. Provides mutual authentication. The HSS delegates the performance of subscriber authentication to the S-CSCF. However the HSS is responsible for generating keys and challenges. The long-term key in the ISIM and the HSS is associated with the IMPI. The subscriber will have several IMS identities i.e. the IMPI and at least one IMPU. The HN authenticates the IMPI.
2. Provides a secure link and a security association between the UE and a P-CSCF for protection of the Gm reference point. For the definition of the Gm reference point cf. TS23.002 [14].
3. Provides security within the network domain internally for the Cx-interface. This security association is covered by TS 33.210 [5]. For the definition of the Cx-interface cf. TS 23.002 [14].
4. Provides security between different networks for SIP capable nodes. This security association is covered by TS 33.210 [5]. Note that the P-CSCF may reside in the HN and in that case bullet point number five applies, cf. also Figure 2 and Figure 3.
5. Provides security within the network internally between SIP capable nodes. This security association is covered by TS 33.210 [5].

There exist other interfaces and reference points in IMS, which has not been addressed above. Those interfaces and reference points reside within the IMS within the same security domain or between different security domains. The protection of all such interfaces and reference points apart from the Gm reference point are protected as specified in TS 33.210 [5].

Mutual authentication is required between the UE and the HN.

The mechanisms specified in this technical specification are independent of the mechanisms defined for the CS- and PS-domain.



An independent IMS security mechanism provides additional protection against security breaches. For example, if the PS-Domain security is breached the IMS would continue to be protected by its own security mechanism. As indicated in Figure 1 the P-CSCF may be located either in the Visited or the Home Network. The P-CSCF shall be co-located with the GGSN, which may reside in either the VPLMN or the HPLMN, cf. TS 23.060 [15].

**P-CSCF in the Visited Network**

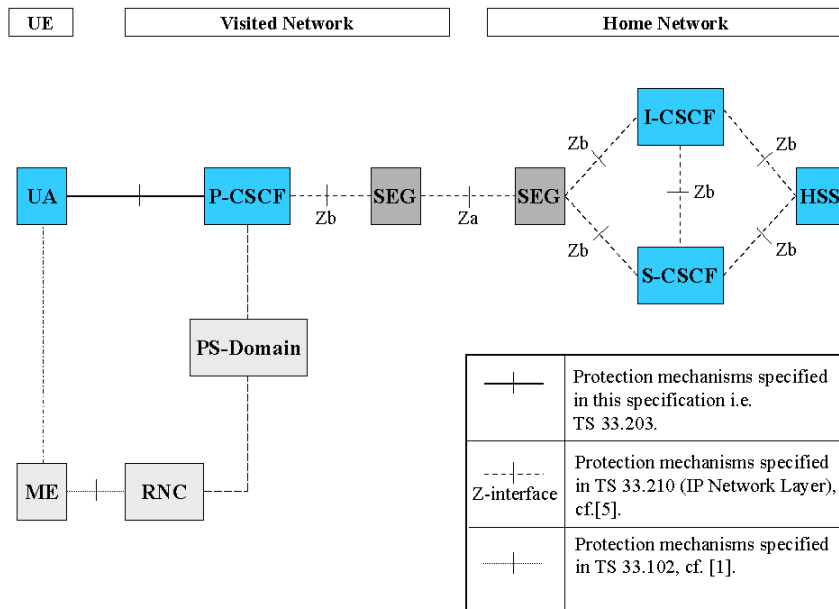

**Figure 2: This figure gives an overview of the security architecture for IMS and the relation with Network Domain security, cf. TS 33.210 [5], when the P-CSCF resides in the VN**

**P-CSCF in the Home Network**

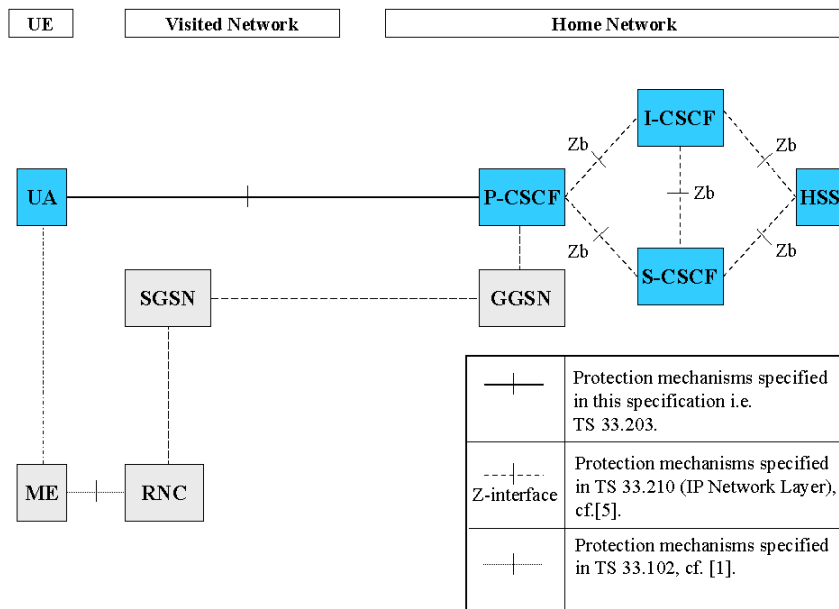

**Figure 3: This figure gives an overview of the security architecture for IMS and the relation with Network Domain security, cf. TS 33.210 [5], when the P-CSCF resides in the HN**

The confidentiality and integrity protection for SIP-signaling is provided in a hop-by-hop fashion, cf. Figure 2 and Figure 3. The first hop i.e. between the UE and the P-CSCF is specified in this technical specification. The other hops, inter-domain and intra-domain are specified in TS 33.210 [5].

[Editors Note The UE Functional split security architecture is FFS e.g. if a section “security for the local interface between the TE and the MT in UE functional split scenarios” would be added to this specification. In this section, it would be pointed out what security features are required on this local interface. Security mechanisms would not be specified, as they would depend on the particular nature of this interface. The new section would also not attempt to assess security mechanisms available for technologies, which may be used to realise this interface (e.g. Bluetooth, Wireless LAN).]

---

## 5 Security features

### 5.1 Secure access to IMS

#### 5.1.1 Authentication of the subscriber and the network

An IM-subscriber will have its subscriber profile located in the HSS in the Home Network. The subscriber profile will contain information on the subscriber that may not be revealed to an external partner, cf. TS 23.228 [3]. At registration an S-CSCF is assigned to the subscriber by the I-CSCF. The subscriber profile will be downloaded to the S-CSCF over the Cx-reference point from the HSS (Cx-Pull). When a subscriber requests an IM-service the S-CSCF will check, by matching the request with the subscriber profile, if the subscriber is allowed to continue with the request or not i.e. Home Control (Authorization of IM-services).

All SIP-signaling will take place over the PS-domain in the user plane i.e. IM-services are essentially an overlay to the PS-domain. Hence the Visited Network will have control of all the subscribers in the PS-domain i.e. Visited Control (Authorization of bearer resources) since the Visited Network provides with a transport service and QoS.

For IM-services a new security association is required between the mobile and the IMS before access is granted to IM-services. The Home Network or a 3rd party even (which does not have to be an UMTS operator) provides the user with the IM-services.

The mechanism for mutual authentication in UMTS is called UMTS AKA. It is a challenge response protocol and the AuC in the Home Stratum derives the challenge. A Quintet containing the challenge is sent from the Home Stratum to the Serving Network. The Quintet contains the expected response XRES and also a message authentication code MAC. The Serving Network compares the response from the UE with the XRES and if they match the UE has been authenticated. The UE calculates an expected MAC, XMAC, and compares this with the received MAC and if they match the UE has authenticated the Serving Network.

The AKA-protocol is a secure protocol developed for UMTS and the same concept/principles will be reused for IM-services and then called IMS AKA.

The Home Network authenticates the subscriber via registrations or re-registrations only.

### 5.1.2 Re-Authentication of the subscriber

The S-CSCF shall be able to initiate an authenticated re-registration of a user at any time, independent of previous registrations, see figure below which defines this requirement.

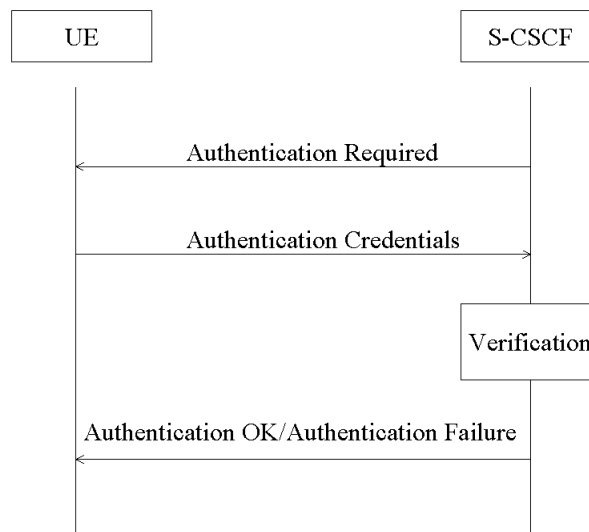

[Editors Note: Solutions for the initiation of network initiated authenticated re-registration shall be elaborated by CN1. The stage 2 information flows shall be included in this specification.]

### 5.1.3 Confidentiality protection

Confidentiality protection shall optionally be used between the UE and the P-CSCF. If it is provided, then it shall be as specified in section 6.2. The UE and P-CSCF shall negotiate what confidentiality algorithm shall be used for the session and shall agree on a confidentiality key  $CK_{IM}$ . The security for SIP-signalling, which is the control plane for IMS, cannot rely on confidentiality being provided in the access network.

Confidentiality between CSCFs, and between CSCFs and the HSS shall rely on mechanisms specified by Network Domain Security in TS 33.210 [5].

[Editor's note: At this stage both Annex B and Annex C provides with potential measures for confidentiality protection. One of these solutions will be the normative solution. Note that for R5 confidentiality measures are optional.]

### 5.1.4 Integrity protection

Integrity protection shall be used end-to-end between the UE and the P-CSCF for protecting the SIP signaling, as specified in section 6.3. The following mechanisms are provided.

- The UE and the P-CSCF shall negotiate what integrity algorithm that shall be used for the session, specified in chapter 7.
- The UE and the P-CSCF shall agree on an integrity key, IK that shall be used for the integrity protection. The mechanism is based on IMS AKA and specified in chapter 6.1.
- The UE and the P-CSCF shall both verify that the data received originates from a node, which has the agreed session key, IK. This verification is also used to detect if the data has been tampered with.

[Editor's note: At this stage both Annex B and Annex C provides with potential measures for integrity protection. One of these solutions will be the normative solution.]

## 5.2 Network topology hiding

The operational details of an operator's network are sensitive business information that operators are reluctant to share with their competitors. While there may be situations (partnerships or other business relations) where the sharing of such information is appropriate, the possibility should exist for an operator to determine whether or not the internals of its network need to be hidden.

It shall be possible to hide the network topology from other operators, which includes the hiding of the number of S-CSCFs, the capabilities of the S-CSCFs and the capability of the network.

The I-CSCF shall have the capability to encrypt the address of an S-CSCF in SIP Via, Record-Route, Route and Path headers and then decrypt the address when handling the response to a request. The P-CSCF may receive routing information that is encrypted but the P-CSCF will not have the key to decrypt this information.

The mechanism shall support the scenario that different I-CSCFs in the HN may encrypt and decrypt the address of the S-CSCFs.

---

# 6 Security mechanisms

## 6.1 Authentication and key agreement

The scheme for authentication and key agreement in the IMS is called IMS AKA. The IMS AKA achieves mutual authentication between the ISIM and the HN, cf. Figure 3. The identity used for authenticating a subscriber is the private identity, IMPI, which has the form of a NAI, cf. TS 23.228 [3]. The HSS and the ISIM share a long-term key associated with the IMPI.

For the IMS the ISIM and the HSS keeps track of the counters  $SQN_{ISIM}$  and  $SQN_{HSS}$ . The handling of the SQN can be as in TS 33.102 [1]. The HN shall choose the IMS AKA scheme for authenticating an IM subscriber accessing through UMTS. The security parameters e.g. keys generated by the IMS AKA scheme are transported by SIP and embedded in EAP, cf. RFC 2284 [7], "draft-arkko-pppext-eap-aka-01" [8] and "draft-torvinen-http-eap-01" [9].

[Editors Note: Shall the HN choose EAP AKA for 3GPP-access or is it to be an option for the HN to choose either EAP AKA or perhaps any other mechanism e.g. HTTP digest depending on policy?]

The generation of the authentication vector AV that includes RAND, XRES, CK, IK and AUTN shall be done in the same way as specified in TS 33.102 [1]. For each user it is the HSS that keeps track of the counter  $SQN_{HSS}$ . The requirements on the SQN handling both in the Home Network i.e. the HSS and the ISIM are specified in TS 33.102 [1]. The AMF field can be used in the same way as in TS 33.102 [1].

Furthermore a security association is established between the UE and the P-CSCF. The subscriber may have several IMPUs associated with one IMPI and belong to the same or different service profiles. Only one SA shall be active between the UE and the P-CSCF. This single SA shall be updated when a new successful authenticated re-registration has occurred, cf. section 7.3.3. It is the policy of the HN that decides if an authentication shall take place for the registration of different IMPUs e.g. belonging to same or different service profiles.

### 6.1.1 Registration of an IM-subscriber

Before a user can get access to the IM services at least one IMPU needs to be registered and the IMPI authenticated in the IMS at application level. In order to get registered the UE sends a SIP REGISTER message towards the SIP registrar server i.e. the S-CSCF, cf. Figure 3, which will perform the authentication of the user.

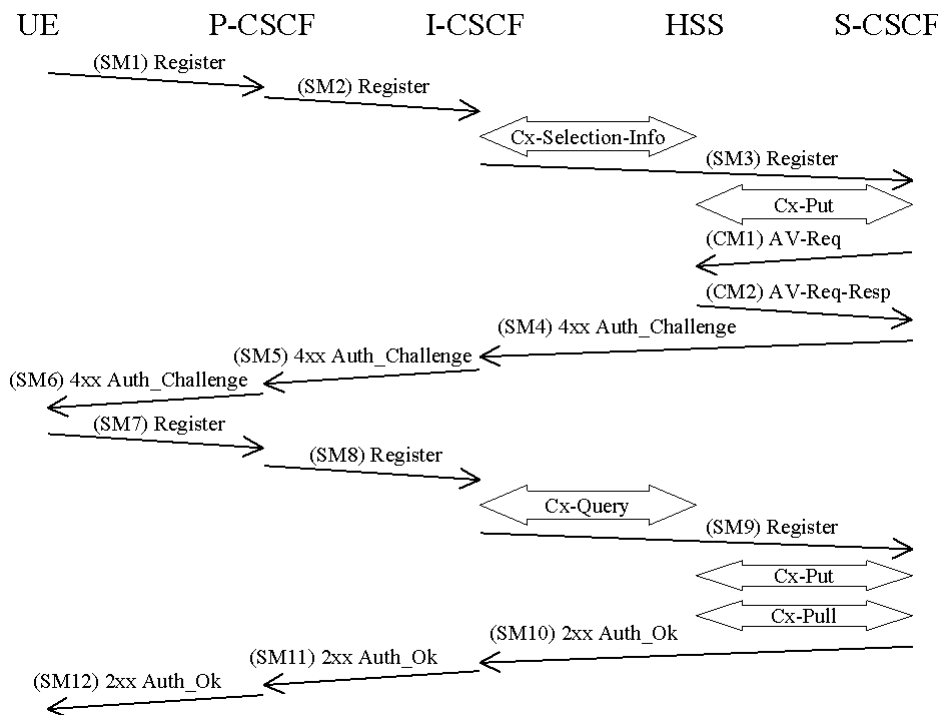

**Figure 3: The IMS Authentication and Key Agreement for an unregistered IM subscriber and successful mutual authentication with no synchronization error**

The flows in more detail (for clarification: TS 24.229, cf. TS 24.229 [13], specifies complete registration flows)

SMn stands for SIP Message n and CMm stands for Cx message m which has a relation to the authentication process:

SM1:  
REGISTER sip: ----

Authorization-EAP(IMPI)
-------------------------

[Editor’s note: This example covers the case when only one public identity is registered. It is still FFS how to treat the case when the subscriber registers several public identities or those IMPUs are implicitly registered.]

The P-CSCF and the I-CSCF forwards the SIP REGISTER towards the S-CSCF and adds a Via header with their addresses included, i.e. SM2 and SM3.

In order to handle mobile terminated calls while the initial registration is in progress and not successfully completed the S-CSCF shall send a registration flag to the HSS. The registration flag shall be stored in the HSS together with the S-CSCF name. The aim of the registration flag is to indicate whether a particular IMPU of the user is unregistered or registered at a particular S-CSCF or if the initial registration at a particular S-CSCF is pending. The HSS receives the information about this state (together with the S-CSCF name and the user identity) from the S-CSCF with which (re-) registration of the user is carried out only when a Cx-Put message is sent from the S-CSCF to the HSS. The registration flag shall be set to *initial registration pending* at the Cx-Put procedure after SM3 has been received by the S-CSCF.

Upon receiving the SIP REGISTER the S-CSCF will need one AV which includes the challenge. As an option the S-CSCF can require more than one AVs. If the S-CSCF has no valid AV then the S-CSCF shall send a request for the AV(s) to the HSS in CM1 together with the number n of AVs wanted where n is at least one but less than or equal to nmax.

[Editor's note: The maximum value of n i.e. nmax has not been defined.]

[Editor's note: Potential failure scenarios and potential extra requirements needed for the handling several AV(s) in the S-CSCF are left FFS.]

CM1:

Cx-AV-Req(IMPI, IMPU, n)

If the HSS has no pre-computed AVs the HSS creates the needed AVs on demand for that user and sends it to the S-CSCF in CM2.

CM2:

Cx-AV-Req-Resp(IMPI, IMPU,n,RAND<sub>1</sub>||AUTN<sub>1</sub>||XRES<sub>1</sub>||CK<sub>1</sub>||IK<sub>1</sub>,...,RAND<sub>n</sub>||AUTN<sub>n</sub>||XRES<sub>n</sub>||CK<sub>n</sub>||IK<sub>n</sub>)

The S-CSCF sends a SIP 4xx Auth\_Challenge i.e. an authentication challenge to the UE including the challenge RAND, the authentication token AUTN in SM4 and the integrity key IK and optionally the cipher key CK.

[Editor's note: It is FFS if re-use and re-transmission of RAND and AUTN is allowed. If allowed the mechanisms have to be defined.]

SM4:

SIP/2.0 4xx Auth\_Challenge

<p><b>WWW-Authenticate-EAP(IMPI, RAND, AUTN)</b> Key parameters(IK, (CK))</p>
---

[Editor's note: The use of KSI i.e. Key Set Identifier for IMS is FFS.]

When the P-CSCF receives SM5 it shall store the key(s) and remove that information and forward the rest of the message to the UE i.e.

SM6:

SIP/2.0 4xx Auth\_Challenge

<p>WWW-Authenticate-EAP(IMPI, RAND, AUTN)</p>
---

Upon receiving the challenge, SM6, the UE takes the AUTN, which includes a MAC and the SQN. The UE calculates the XMAC and checks that XMAC=MAC and that the SQN is in the correct range as in TS 33.102 [1]. If both these checks are successful the UE calculates the response, RES, puts it into the Authorization header and sends it back to the registrar in SM7. It should be noted that the UE at this stage also computes the session keys CK and IK.

SM7:  
REGISTER sip: ----

Authorization-EAP(*IMPI, RES*)

The P-CSCF forwards the RES in SM8 to the I-CSCF, which queries the HSS to find the address of the S-CSCF. In SM9 the I-CSCF forwards the RES to the S-CSCF.

Upon receiving the response, RES, the S-CSCF retrieves the active XRES for that user and checks if XRES=RES. If the check is successful then the user has been authenticated and the IMPU is registered in the S-CSCF. To ensure that the S-CSCF is able to take the decision whether a subsequent registration shall trigger a new authentication and to be able to check that all INVITE messages will be sent to/from an authorized subscriber it shall be possible to implicitly register IMPU(s). The implicitly registered IMPU(s) all belong to the same Service Profile. All the IMPU(s) being implicitly registered shall be delivered by the HSS to the S-CSCF. The S-CSCF shall regard all implicitly registered IMPU(s) as registered IMPU(s).

[Editor's note: Since implicitly registered IMPUs are not available in the P-CSCF this functionality opens up a weakness in the IMS security architecture. Requirements that closes this weakness needs to be defined and is left FFS.]

At this stage the S-CSCF shall send in the Cx-Put after receiving SM9 an update of the registration-flag. If the authentication of the subscriber is successful the registration flag shall take the value *registered*. When the authentication is unsuccessful the registration flag shall be set to *unregistered*.

When a subscriber has been registered this registration will be valid for some period of time. Both the UE and the S-CSCF will keep track on a timer for this purpose but the expiration time in the UE is smaller than the one in the S-CSCF in order to make it possible for the UE to be registered and reachable without interruptions. The UE initiated re-registration opens up a potential denial-of-service attack in the sense that an attacker could re-register a subscriber and respond with the wrong RES and the HN could then de-register the subscriber. It shall be defined by the policy of the operator when successfully registered IMPU(s) are to be de-registered.

The authenticated re-registration looks the same as the initial registration except that CM1 and CM2 can be omitted as long as the S-CSCF has valid AV(s). At a re-registration the registration flag has already the value *registered*. The policy of the home provider states whether the flag shall be changed at a re-registration. There are two cases:

- The IMS subscriber is de-registered after unsuccessful registration. In this case the registration flag shall be set to *unregistered* and an error message shall be sent to from the S-CSCF to the HSS.
- The IMS subscriber remains registered after unsuccessful re-registration. In this case the registration flag is kept in the HSS to the value *registered* even if the authentication was unsuccessful.

The lengths of the IMS AKA parameters are specified in section 6.3.7 of TS 33.102 [1].

## 6.1.2 Authentication failures

[Editor's note: This subsection shall deal with the requirements for network and user authentication failures.]

### 6.1.2.1 User authentication failure

When the check of the RES in the S-CSCF fails the user can not be authenticated and hence registration fails. The flow is identical as for the successful registration in 6.1.1 up to SM9.

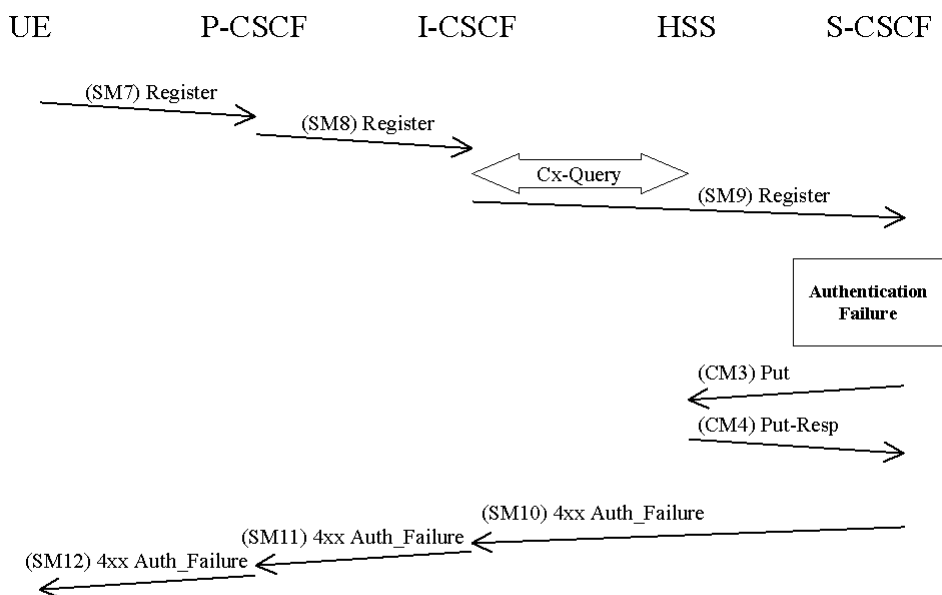

CM3:

Cx-AV-Put(IMPI, IMPU, Clear S-CSCF name)

The S-CSCF sends a Cx-Put (CM3) to the HSS, which indicates that authentication failed and that, the S-CSCF should be cleared for that particular IMPU. The HSS responds with a Cx-Put-Resp in CM4. In SM10 the S-CSCF sends a 4xx Auth\_Failure towards the UE indicating that the authentication failed, no security parameters shall be included in this message.

SM10:

SIP/2.0 4xx Auth\_Failure

Upon receiving SM10 the I-CSCF shall clear any registration information related to the IMPU.

[Editors Note: It is FFS if the IMPI shall be included in SM10.]

### 6.1.2.2 Network authentication failure

In this section the case when the authentication of the network is not successful is specified. When the check of the MAC in the UE fails the network can not be authenticated and hence registration fails. The flow is identical as for the successful registration in 6.1.1 up to SM6.



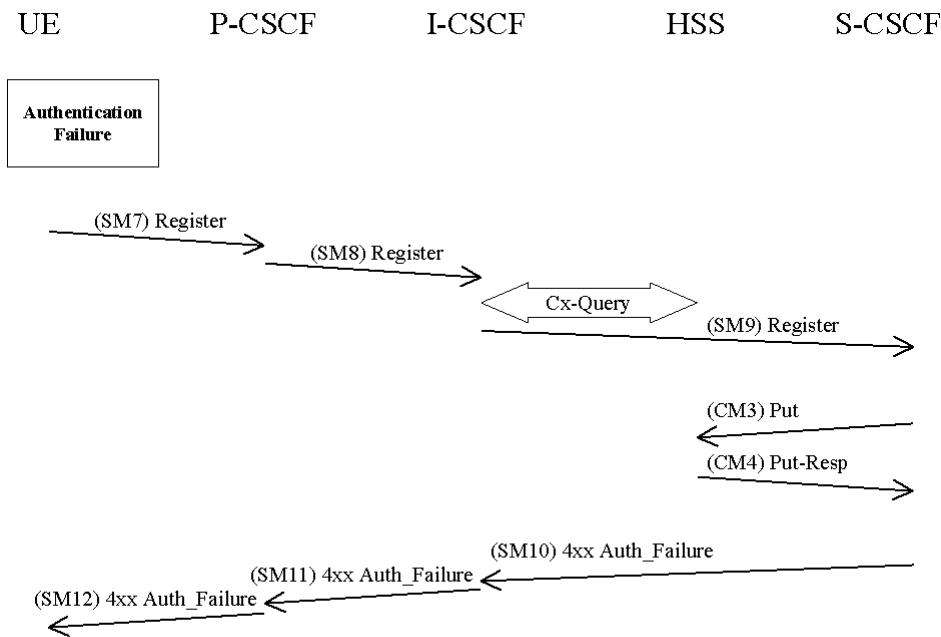

The UE shall send a Register message towards the HN including an indication of the cause of failure in SM7. The P-CSCF and the I-CSCF forward this message to the S-CSCF.

SM7:  
REGISTER sip: ----

Failure(AuthenticationFailure, IMPI)

Upon receiving SM9, which includes the cause of authentication failure, the S-CSCF sends a Cx-Put in CM3 and receives a Cx-Put-Resp in CM4. The S-CSCF sends a 4xx Auth\_Failure towards the UE. The messages CM3, CM4 and SM10-SM12 shall be the same as in 6.1.2.1.

[Editor’s note: It is FFS if same header i.e. 4xx Auth\_Failure shall be used for both UE and network authentication failure.]

### 6.1.4 Synchronization failure

[Editor’s note: This subsection shall deal with the requirements for the case when the SQNs in the ISIM and the HSS are not in synch.]

In this section the case of an authenticated registration with synchronization failure is described. After re-synchronization, authentication may be successfully completed, but it may also happen that in subsequent attempts other failure conditions (i.e. user authentication failure, network authentication failure) occur. In below only the case of synchronization failure with subsequent successful authentication is shown. The other cases can be derived by combination with the flows for the other failure conditions.

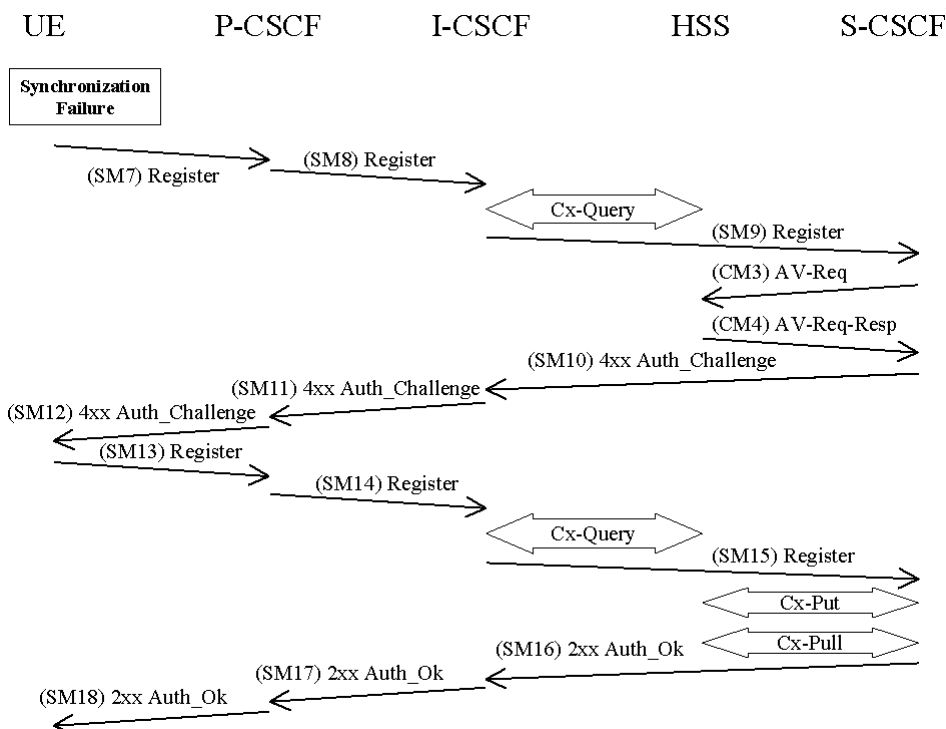

The flow equals the flow in 6.1.3.1 up to SM6. When the UE receives SM6 it detects that the SQN is out of range and sends a synchronization failure back to the S-CSCF in SM7.

SM7:  
REGISTER sip: ----

Failure(*Synchronization Failure, AUTS, IMPI*)

Upon receiving the *Synchronization Failure* and the AUTS the S-CSCF sends an Av-Req to the HSS in CM3 including the required number of Avs, n.

CM3:  
Cx-AV-Req(IMPI, IMPU, RAND,AUTS, n)

The HSS checks the AUTS as in section 6.3.5 in TS 33.102 [1]. If the check is successful and potentially after updating the SQN the HSS creates and sends new AVs to the S-CSCF in CM4.

CM4:  
Cx-AV-Req-Resp(IMPI, IMPU,n,RAND<sub>1</sub>||AUTN<sub>1</sub>||XRES<sub>1</sub>||CK<sub>1</sub>||IK<sub>1</sub>,...,RAND<sub>n</sub>||AUTN<sub>n</sub>||XRES<sub>n</sub>||CK<sub>n</sub>||IK<sub>n</sub>)

The rest of the messages i.e. SM10-SM18 including the Cx messages are exactly the same as SM4-SM12 and the corresponding Cx messages in 6.1.1.

## 6.2 Confidentiality mechanisms

[Editor’s note: This section shall deal with cipher algorithms used between the UE and the P-CSCF]

[Editor’s note: At this stage both Annex B and Annex C provides with potential measures for confidentiality protection. One of these solutions will be the normative solution. Note that for R5 confidentiality measures are optional.]

## 6.3 Integrity mechanisms

[Editor's note: At this stage both Annex B and Annex C provides with potential measures for integrity protection. One of these solutions will be the normative solution.]

## 6.4 Hiding mechanisms

The Hiding Mechanism is optional for implementation. All I-CSCFs in the HN shall share the same encryption and decryption key  $K_v$ . If the mechanism is used and the operator policy states that the topology shall be hidden the I-CSCF shall encrypt the hiding information elements when the I-CSCF forwards SIP Request or Response messages outside the hiding network's domain. The hiding information elements are entries in SIP headers, such as Via, Record-Route, Route and Path, which contain addresses of SIP proxies in hiding network. When I-CSCF receives a SIP Request or Response message from outside the hiding network's domain, the I-CSCF shall decrypt those information elements that were encrypted by I-CSCF in this hiding network domain.

The purpose of encryption in network hiding is to protect the identities of the SIP proxies and the topology of the hiding network. Therefore, an encryption algorithm in confidentiality mode shall be used. The network hiding mechanism will not address the issues of authentication and integrity protection of SIP headers. The AES in CBC mode with 128-bit block and 128-bit key shall be used as the encryption algorithm for network hiding. In the CBC mode under a given key, if a fixed IV is used to encrypt two same plaintexts, then the ciphertext blocks will also be equal. This is undesirable for network hiding. Therefore, random IV shall be used for each encryption. The same IV is required to decrypt the information. The IV shall be included in the same SIP header that includes the encrypted information.

[Editor's note: The following open issues are still to be resolved:

- use of a key identifier for the support of multiple encryption secret keys
- possible use of a MAC to protect integrity of the resulting cipher text
- impact on compressibility of incoming SIP messages
- key management and distribution amongst I-CSCFs
- implications on development of SIP are to be considered

]

---

# 7 Security association set-up procedure

The security association set-up procedure is necessary in order to decide what security services that apply and when the security services start. In the IMS authentication of users is performed during registration as in Section 6.1. Subsequent signaling communications in this session will be integrity and optionally confidentiality protected based on the keys derived during the authentication process.

## 7.1 Security association parameters

For protecting IMS signaling between the UE and the P-CSCF it is necessary to agree on shared keys provided by IMS AKA, on certain protection methods (e.g. an integrity protection method) and a set of parameters specific to a protection method, e.g. the cryptographic algorithm to be used. The parameters negotiated are typically part of the security association to be used for a protection method.

The security mode setup shall support the negotiation of different protection mechanisms. It shall be able to negotiate or exchange the SA parameters required for these different protection mechanisms. Although the supported protection mechanisms could be quite different, there is a common set of parameters that have to be negotiated for each of them. This set of parameters includes:

- Authentication (integrity) algorithm, and optionally encryption algorithm
- SA\_ID that is used to uniquely identify the SA at the receiving side.
- Key length: the length of encryption and authentication (integrity) keys is 128 bits.

Parameters specifically related to certain protection methods are kept in the annexes describing the protection methods.

The SA between the UE and the P-CSCF will have a limited lifetime. The lifetime timer shall be the same as the registration timer, which is defined per contact address. When the UE registers the registration timer will be negotiated between the UE, the P-CSCF and the S-CSCF. The S-CSCF will be able to accept, decrease or increase the proposed expiration time from the UE and the final value is sent in the response to the UE. The expiry time in the UE will be shorter than the expiry time in the S-CSCF, such that the UE is able to re-register. For each new successful authentication the SA shall be updated. The S-CSCF shall align the expiration of subsequent registrations with any existing registration timer. The SA is deleted if the registration timers expires in the P-CSCF or in the S-CSCF.

[Editors Note: The support of different mechanisms is FFS.]

## 7.2 Set-up of security associations (successful case)

In this section the normal case is specified i.e. when no failures occurs. Note that for simplicity some of the nodes and messages have been omitted.

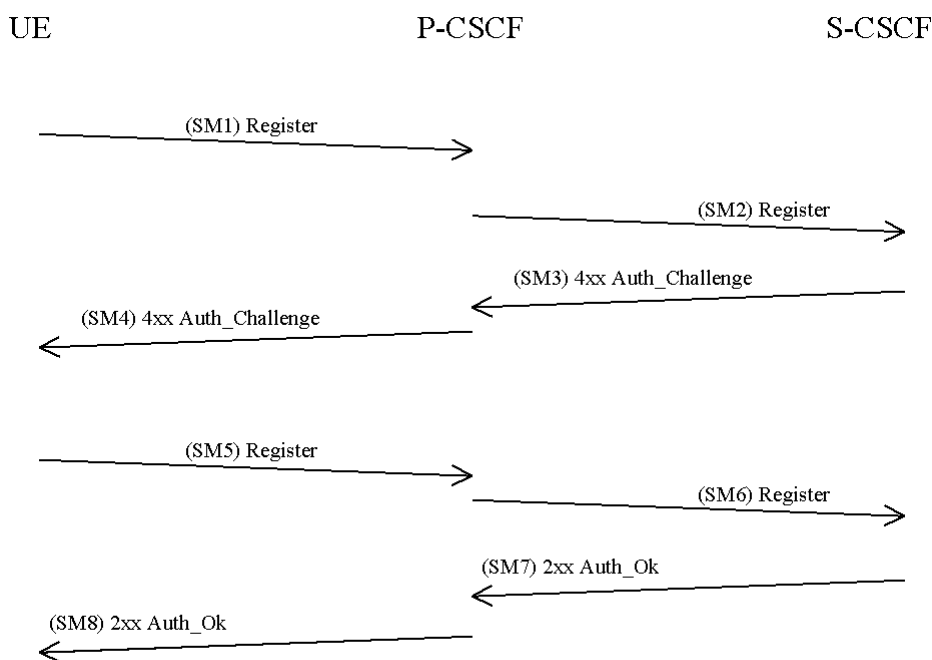

The UE sends a Register message towards the S-CSCF to register the location of the UE and to set-up the security mode. This has been described in 6.1. In order to start security mode setup the UE shall include a *Security-setup*: line in this message, including the protection method, the proposed set of integrity algorithms, the proposed set of confidentiality algorithms (optional), the SA\_ID and an optional *info* field. The *info* field is reserved for method specific use, so any method supported by the security mode set-up must specify whether and how to use the *info* field. The SA\_ID\_U shall be chosen in such a way that it uniquely identify the (unidirectional) inbound SA at the UE side, within the UE.

Elements in [...] are optional.

SM1:  
REGISTER sip: ---

Security-setup(*integrity mechanisms list*, [*confidentiality mechanisms list*], *integrity algorithms list*, [*confidentiality algorithms list*], SA\_ID\_U, [*info*])  
Authorization-EAP(IMPI)

The P-CSCF shall choose exactly one of the proposed mechanisms respectively and exactly one of the proposed algorithms respectively based on the policies that applies and send the selected mechanisms and algorithms to the UE in SM4.

The SA\_ID\_P shall be chosen in such a way that it uniquely identifies the (unidirectional) inbound SA at the P-CSCF side, within the P-CSCF.

[Editors Note: It is FFS if the HN shall take part in the negotiation of algorithms.]

SM4:

SIP/2.0 4xx Auth\_Challenge

Security-setup(*integrity mechanisms list*, [*confidentiality mechanisms list*], *integrity algorithms list*, [*confidentiality algorithms list*], SA\_ID\_P, [*info*])  
Authorization-EAP(*IMPI*)

The UE shall in SM5 start the integrity protection – and optionally the confidentiality protection – of the whole SIP-message by setting up security associations according to mechanisms and the parameters negotiated in SM1 and SM4, and applying the corresponding protection to the SIP-message. Furthermore the Security-setup: line sent in SM1 shall be included:

SM5:

REGISTER sip: ----

Security-setup(*integrity mechanisms list*, [*confidentiality mechanisms list*], *integrity algorithms list*, [*confidentiality algorithms list*], SA\_ID\_U, [*info*])  
Authorization-EAP(*IMPI*)

After receiving SM5 from the UE, the P-CSCF shall compare the Security-Setup line of this message with the Security-Setup line received in SM1.

The P-CSCF finally sends SM8 to the UE. SM8 does not contain information specific to security mode setup (i.e. a Security-setup line), but with sending SM8 not indicating an error the P-CSCF confirms that security mode setup has been successful. After receiving SM8 not indicating an error, the UE can assume the successful completion of the security-mode setup.

[Editors Note: It is FFS if the HN shall take part in the negotiation process.]

## 7.3 Error cases in the set-up of security associations

Whenever an expected message is not received after a time-out the receiving entity considers the registration to have failed.

[Editor's note: Clarify, how SIP registration handles the inconsistent state that is created by a lost SM8 message]

### 7.3.1 Error cases related to IMS AKA

Errors related to IMS AKA failures are specified in section 6.1. However, this section additionally describes how these shall be treated, related to security setup.

[Editors Note: It is FFS if this is appropriate taking DoS attacks into account.]

#### 7.3.1.1 User authentication failure

In this case the authentication of the user fails in the network due an incorrect RES. The S-CSCF will send a 4xx Auth\_Failure message SM7, which will pass through the already established SA to the UE as SM8.

Note, that this failure will already occur in SM5, when the UE does not use the correct integrity key IK. In this situation, the P-CSCF will receive protected packets that cannot be verified.

It may seem from the above discussion that there is no requirement to check the RES at the S-CSCF since a false RES sent by a UE will never reach the S-CSCF. However, it is still necessary to check RES at the S-CSCF since this prevents a P-CSCF from registering a UE without performing user authentication. It therefore reduces S-CSCF trust in the P-CSCF.

### 7.3.1.2 Network authentication failure

If the UE is not able to successfully authenticate the network, the UE is not able to create the key IK and therefore the SA with the P-CSCF, such that it is not possible to send SM5 in a protected way. Since the P-CSCF already expects SIP messages from the UE to be protected, and is not already aware of any errors, the P-CSCF shall accept such REGISTER messages indicating network authentication failure in the clear.

So the UE sends a new register message SM5, indicating a network authentication failure, to the P-CSCF, without protection. SM5 should not contain the security-setup line of the first message.

### 7.3.1.3 Synchronisation failure

In this situation, the UE observes that the AUTN sent by the network in SM4 contains an out-of-range sequence number. The UE shall send a new register message SM5 to the P-CSCF in the clear, indicating the synchronization failure. SM5 should not contain the Security-Setup line of the first message, and the P-CSCF shall keep the security-setup state created after receiving SM1 from the UE.

## 7.3.2 Error cases related to the Security-Set-up

### 7.3.2.1 Unacceptable proposal set

In this case the P-CSCF cannot accept the proposal set sent by the UE in the Security-Set-up command of SM1. SM4 shall respond to SM1 with indicating a failure, by sending a 4xx Unacceptable\_Proposal.

The P-CSCF therefore shall modify the message SM2 such that the S-CSCF sends a 4xx Unacceptable\_Proposal message back to the UE in SM3/4 and the registration process is finished.

SM2:

REGISTER sip: ----

Security-setup( <i>integrity mechanisms list</i> , [ <i>confidentiality mechanisms list</i> ], <i>integrity algorithms list</i> , [ <i>confidentiality algorithms list</i> ], <i>SA_ID_U</i> , [ <i>info</i> ]) Authorization-EAP( <i>IMPI</i> ) Failure( <i>NoCommonIntegrityAlgorithm</i> )
---

[Editors Note: It is FFS how the exact mechanism shall be for the Unacceptable proposal set case. The editor believes that the S-CSCF is the registrar and hence the P-CSCF should only be able to modify the headers and not send back responses. The failure response should be sent by the S-CSCF. This however has not been agreed.]

### 7.3.2.2 Unacceptable algorithm choice

If the P-CSCF sends in the security-setup line of SM4 an algorithm that is not acceptable for the UE (i.e. has not been proposed), the UE shall not continue to create a security association with the P-CSCF and shall terminate the registration procedure.

### 7.3.2.3 Failed consistency check of Security-Set-up lines

This is the case if the Security-Setup line in SM5 from the UE to the P-CSCF cannot be verified, so the Security-Setup line of the unprotected SM1 and the Security-Setup line of the protected SM5 do not match. The P-CSCF shall respond to the UE by sending a 4xx Unacceptable\_Proposal message in SM8. The P-CSCF therefore shall modify the message SM6 such that the S-CSCF sends a 4xx Unacceptable\_Proposal message back to the UE in SM7/8 and the registration process is finished.

SM6:

REGISTER sip: ----

Security-setup(*integrity mechanisms list*, [*confidentiality mechanisms list*], *integrity algorithms list*, [*confidentiality algorithms list*], SA\_ID\_U, [*info*])

Authorization-EAP(*IMPI*)

Failure(*NoCommonIntegrityAlgorithm*)

[Editors Note: It is FFS how the exact mechanism shall be for the Unacceptable proposal set case. The editor believes that the S-CSCF is the registrar and hence the P-CSCF should only be able to modify the headers and not send back responses. The failure response should be sent by the S-CSCF. This however has not been agreed.]

### 7.3.3 Authenticated re-registration

If the registration is a re-registration, a pair of security associations between UE and P-CSCF is already active.

[Editors Note: It is FFS if these SAs shall protect the first two messages of the authenticated re-registration, i.e. SM1 and SM4.]

Before SM5 is sent by the UE, both peers shall replace the existing SA by the new SA negotiated during these first two messages.

#### 7.3.3.1 Handling of security associations in authenticated re-registrations (successful case)

Before re-registration begins the following SAs exist:

- SA1 from UE to P-CSCF
- SA2 from P-CSCF to UE

The re-registration then is as follows:

- 1) The UE sends SM1 to re-register with the IMS, using the existing SA1 to the P-CSCF. As in the case of a new registration, a list of parameters to be negotiated in a security association set-up is included.

[Editors Note: It is FFS if the SA1 shall be used for SM1 or not]

- 2) The P-CSCF waits for the response SM3 from the S-CSCF and then sends SM4 to the UE, using SA2. As in the case of a new registration, the parameters selected for the new security associations are included. The P-CSCF then creates two new security associations, in parallel to the existing ones, in its database:

- - SA11 from UE to P-CSCF
- - SA12 from P-CSCF to UE

- 3) If SM4 could be successfully processed by the UE, the UE also creates the new SAs SA11 and SA12 in its database. The UE then sends SM5 to the P-CSCF. As in the case of a new registration, the authentication response and the list of parameters repeated from message 1 are included. SM5 is protected with the new SA11.
- 4) The P-CSCF waits for the response SM7 from the S-CSCF and then sends SM8 to the UE, using the new SA 12.
- 5) After the reception of SM8 by the UE, the re-registration is complete.

The UE now uses the new SAs for all subsequent messages. The old (outbound) SA1 is deleted. The old (inbound) SA2 must be kept until a further SIP message protected with the new inbound SA12 is successfully received from the P-CSCF.

The P-CSCF keeps all four SAs with the UE active until a further SIP message protected with the new inbound SA11 is successfully received from the UE. In the meantime, the P-CSCF continues to use the old SA2 for outbound traffic to the UE.

### 7.3.3.2 Error cases related to authenticated re-registration

Whenever an expected message is not received after a time-out the receiving entity considers the registration to have failed. The receiving entity then deletes any new security associations it may have established and continues to use the old ones if they have not yet expired.

If the registration protocol goes well up to the last message SM8, and SM8 is sent by the P-CSCF, but not received by the UE, then the UE has only the old SAs available (after the time-out), but the P-CSCF cannot know this. Therefore, the P-CSCF continues to use the old SA2 for outbound traffic to the UE, but keeps both, old and new SAs. The new SAs are deleted when a message is received from the UE which is protected with the old SA, or if a REGISTER message is received on the port where the P-CSCF accepts specific unprotected messages.

### 7.3.3.3 Error cases related to IMS AKA

#### User authentication failure

The S-CSCF will send a 4xx Auth\_Failure message SM7, which will pass through the already established SA to the UE as SM8. Afterwards, both, the UE and the P-CSCF delete the new SAs.

#### Network authentication failure

If the UE is not able to successfully authenticate the network, it does not establish a new SA. The UE sends a REGISTER message SM5 indicating a network authentication failure to the P-CSCF, using the already established SA. The P-CSCF deletes the new SAs after receiving this message.

#### Synchronisation failure

If the UE notices a synchronisation failure it does not establish a new SA. The UE sends a message SM5, indicating the synchronisation failure, to the P-CSCF, using the already established SA. The P-CSCF deletes the new SA after receiving this message.

### 7.3.3.4 Error cases related to the Security-Setup

#### Unacceptable proposal set

The message SM4 shall respond to the first REGISTER message SM1 with a 4xx Unacceptable\_Proposal, using the already established SA. Neither side establishes a new SA.

The P-CSCF therefore shall modify the message SM2 such that the S-CSCF sends the 4xx Unacceptable\_Proposal message back to the UE in SM3/4 and the registration process is finished.

#### SM2:

REGISTER sip: ----

Security-setup( <i>integrity mechanisms list</i> , [ <i>confidentiality mechanisms list</i> ], <i>integrity algorithms list</i> , [ <i>confidentiality algorithms list</i> ], SA_ID_U, [ <i>info</i> ]) Authorization-EAP(IMPI) Failure( <i>NoCommonIntegrityAlgorithm</i> )
--

[Editors Note: It is FFS how the exact mechanism shall be for the Unacceptable proposal set case. The editor believes that the S-CSCF is the registrar and hence the P-CSCF should only be able to modify the headers and not send back responses. The failure response should be sent by the S-CSCF. This however has not been agreed.]



### Failed consistency check of Security-Set-up lines

This is the case if the Security-Setup line in SM5 from the UE to the P-CSCF cannot be verified, so the Security-Setup line of the unprotected SM1 and the Security-Setup line of the protected SM5 do not match. In this case the P-CSCF shall respond to the UE by sending a 4xx Unacceptable\_Proposal message in SM8 using the already established SA. Both sides delete the new SAs.

The P-CSCF therefore shall modify the message SM6 such that the S-CSCF sends the 4xx Unacceptable\_Proposal message back to the UE in SM7/8 and the registration process is finished.

SM6:

REGISTER sip: ----

Security-setup( <i>integrity mechanisms list</i> , [ <i>confidentiality mechanisms list</i> ], <i>integrity algorithms list</i> , [ <i>confidentiality algorithms list</i> ], SA_ID_U, [ <i>info</i> ]) Authorization-EAP(IMPI) Failure( <i>NoCommonIntegrityAlgorithm</i> )
--

[Editors Note: It is FFS how the exact mechanism shall be for the Unacceptable proposal set case. The editor believes that the S-CSCF is the registrar and hence the P-CSCF should only be able to modify the headers and not send back responses. The failure response should be sent by the S-CSCF. This however has not been agreed.]

---

## 8 ISIM

The ISIM is logically independent from the USIM to represent the IMS subscription and its associated data. It is necessary for this subscription information to be independent of the corresponding USIM data to support access network independence. Furthermore the IMPI, the Home Network Domain Name and at least one IMPU shall be securely stored on the UICC i.e. the logically separate ISIM. The ISIM and USIM may be implemented on the same UICC, and may be provisioned by the same provider. Although ISIM and USIM are logically independent, all the following cases are possible for implementation:

- ISIM and USIM are implemented as a single application inside one UICC
- ISIM and USIM are implemented as two distinct applications inside one UICC
- ISIM and USIM are implemented inside two distinct UICCs.

[Editors Note: It is FFS if and how a R'99 and R'4 USIM can be reused for IMS. Open issues related to this are:

- Increased signaling load due to re-synchronization's
- Derivation of the IMPI from the IMSI
- Protection of IMSI from eavesdropping i.e. user identity confidentiality
- Derivation of IMPUs. Note that MSISDN is not compulsory in the USIM so the IMPU can not always be derived from that
- Which scenario to support i.e. R'99 USIM and no IMS data is stored on the UICC or R'5 USIM and IMS data is stored on the UICC and IMS security parameters are derived with existing R'99 AKA sequence]

There shall only be one ISIM for each IMPI. The USIM and the ISIM may share the same algorithms and the same long-term key. It is an operator choice if the long-term key and the algorithms are different. The IMS subscriber shall not be able to modify or enter the IMPI. The IMS subscriber shall not be able to modify or enter the Home Domain Name.

The ISIM shall include:

- The IMPI
- At least one IMPU
- Home Network Domain Name
- Support for SQN used in the context of the IMS Domain
- The same framework for algorithms as specified for the USIM applies for the ISIM
- Authentication Key

The ISIM shall deliver the CK to the UE although it is not required that SIP signaling is confidentiality protected.

[Editors Note: It is FFS if a KSI, data equivalent to the START parameter, AMF related data, storage for CK and IK is needed or not.]

[Editors Note: It is FFS if an IMS subscriber shall be de-registered at power off]

Annexes are only to be used where appropriate:

---

Annex <A> (normative):  
<Normative annex title>

---

## Annex B (Informative): Mechanisms for IPsec based solution

[Editors Note: If the IPsec solution is finally chosen the chapters below shall be moved into the main body of this TS in the corresponding sections.]

### B.1 6.2 Confidentiality mechanisms

IPsec ESP may optionally be implemented for providing confidentiality of SIP signalling between the UE and the P-CSCF, protecting all SIP signalling messages at the IP level. If ESP confidentiality is used, it shall be applied in transport mode between UE and P-CSCF. If ESP confidentiality is provided, it is always provided in addition to ESP integrity protection.

The SAs that are required for ESP shall be derived from the 128-bit integrity key  $CK_{IM}$  generated through IMS AKA, as specified in chapter 6.1.

If confidentiality is required, for each direction, there is one ESP SA for both confidentiality and integrity that shall be used between the UE and the P-CSCF. The encryption transform is identical for the two SAs in either direction. The encryption key for the SA inbound from the P-CSCF is CK.

The encryption key for the SA inbound from the P-CSCF is  $CK_{IM\_in}$ . The encryption key for the SA outbound from the P-CSCF is  $CK_{IM\_out}$ .

The encryption keys are derived as  $CK_{IM\_in} = h1(CK_{IM})$  and  $CK_{IM\_out} = h2(CK_{IM})$  using suitable key derivation functions h1 and h2.

The encryption key derivation on the user side is done in the ISIM. The encryption key derivation on the network side is done in the P-CSCF.

The method to set up ESP security associations during the SIP registration procedure is specified in chapter 7.

### B.2 6.3 Integrity mechanisms

IPsec ESP shall provide integrity protection of SIP signalling between the UE and the P-CSCF, protecting all SIP signalling messages at the IP level. ESP integrity shall be applied in transport mode between UE and P-CSCF.

The SAs that are required for ESP shall be derived from the 128-bit integrity key IK generated through IMS AKA, as specified in chapter 6.1. The transform used for the ESP SA shall be negotiated as specified in chapter 7. ESP shall use two unidirectional SAs between the UE and the P-CSCF, one in each direction. The integrity algorithm is identical for both SAs.

The integrity key for the SA inbound from the P-CSCF is  $IK_{IM\_in}$ . The integrity key for the SA outbound from the P-CSCF is  $IK_{IM\_out}$ .

The integrity keys are derived as  $IK_{IM\_in} = h1(IK_{IM})$  and  $IK_{IM\_out} = h2(IK_{IM})$  using suitable key derivation functions h1 and h2. (They may be the same as those in section 6.2.)

The integrity key derivation on the user side is done in the ISIM. The integrity key derivation on the network side is done in the P-CSCF.

The method to set up ESP security associations during the SIP registration procedure is specified in chapter 7.

---

## Annex C (Informative): Mechanisms for SIP-level solution

[Editors Note: If the SIP-level solution is finally chosen the chapters below shall be moved into the main body of this TS in the corresponding sections.]

### C.1 6.2 Confidentiality mechanisms

[Editor's note: This section shall deal with cipher algorithms]

### C.2 6.3 Integrity mechanisms

[Editors note: There seems to be an unexpected shortcoming in the way SIP provides integrity protection on messages between UE and Proxies. In current SIP, HTTP Digest can be used to partially integrity protect the messages originated by an UE. However, SIP fails to provide integrity for Proxy to UE communication, i.e. for terminating INVITEs, for example. Proxies are not able to add Authorization headers on these messages, thus leaving the messages unprotected.

For the reason above, the headers and field names used in this section may not be final. However, the found inconsistency will probably make it easier for 3GPP to discuss about new SIP level integrity protection schemes with IETF.]

HTTP Digest shall provide integrity protection of SIP signalling between the UE and the P-CSCF, protecting all SIP signalling messages at the SIP level.

The SA that is required for Digest integrity protection shall use the 128-bit integrity key IK generated through IMS AKA, as specified in section 6.1. The integrity algorithm and key are identical for integrity protection applied to messages travelling in either direction. Negotiation of the integrity algorithm to use occurs in the following way: The UE communicates the set of integrity algorithms that it supports to the P-CSCF through the Security-setup header field of the REGISTER message, as described in section 7.2. The P-CSCF selects an algorithm to use from the set of algorithm capabilities common to both the UE and the P-CSCF. The P-CSCF indicates the algorithm to use in the "algorithm" directive of the Digest challenge that is subsequently issued to the UE.

**Digest supports integrity protection of the SIP message body (not the headers) when the "qop-options" directive within the Digest challenge is set to the value "int". Digest supports integrity protection of the entire SIP message when the "qop-options" directive within the Digest challenge is set to the value "extended-int".** (Use of either of these values of "qop-options" assumes that a context of client authentication has been previously established.) To provide for protection of the entire SIP message, the P-CSCF shall issue a Digest challenge to the UE specifying the value "extended-int" for the "qop-options" directive.

The message 'digest', or message authentication code, is conveyed in the "response" directive of the Digest response. The rules for computing "response" are as described in TS 33.102 [1] with the following consideration: if the UE receives a Digest challenge with the "qop-options" directive set to either "int" or "extended-int", and the associated authentication challenge was an IMS AKA challenge, then the UE substitutes IK for the "password" component of A1 when computing "response=" in the Digest response. The UE sets the "username" component of A1 to a fixed value (e.g., "ims-user"). When sending messages to the UE that are to be integrity protected, the P-CSCF applies the same rules when computing "response". In this manner, the whole SIP message is always protected.

The Digest framework specifies that a server-initiated nonce is to be used by the client as a random number input to the production of the message digest. This nonce, along with a counter that is incremented by either endpoint when sending a message that is to be protected, facilitate anti-replay protection.

In the 3GPP IMS, then, normal operation of the Digest challenge-response mechanism for integrity protection is as follows:

Per RFC 2617, the Digest challenge-related directives are carried in either the WWW-Authenticate or Proxy-Authenticate header fields. The P-CSCF adds a Proxy-Authenticate header field to the 4xx Auth\_Challenge that is sent by the S-CSCF (SIP registrar) toward the UE; the Proxy-Authenticate contains the Digest challenge that has been constructed by the P-CSCF.

Per RFC 2617, the Digest response-related directives are carried in either the Authorization or Proxy-Authorization header fields, depending upon which header field carried the corresponding Digest challenge. These directives contain the credentials for the message integrity check. In the IMS context, the UE responds to the initial Digest challenge by adding a Proxy-Authorization header field to the REGISTER toward the S-CSCF (registrar). The UE pre-emptively adds a Proxy-Authorization header field to all subsequent UE-initiated SIP requests. The UE and the P-CSCF add the Authentication-Info header to all SIP responses. **Finally, the P-CSCF adds an Integrity header field to all SIP requests sent toward the UE.** The simplified message flow shown below illustrates the relevant header fields and contents for the SIP-level integrity protection mechanism. Please note that the message flow contains three cases: a registration (1-3), and two SIP sessions: one UE initiated (4-5) and one UE terminated (6-7).

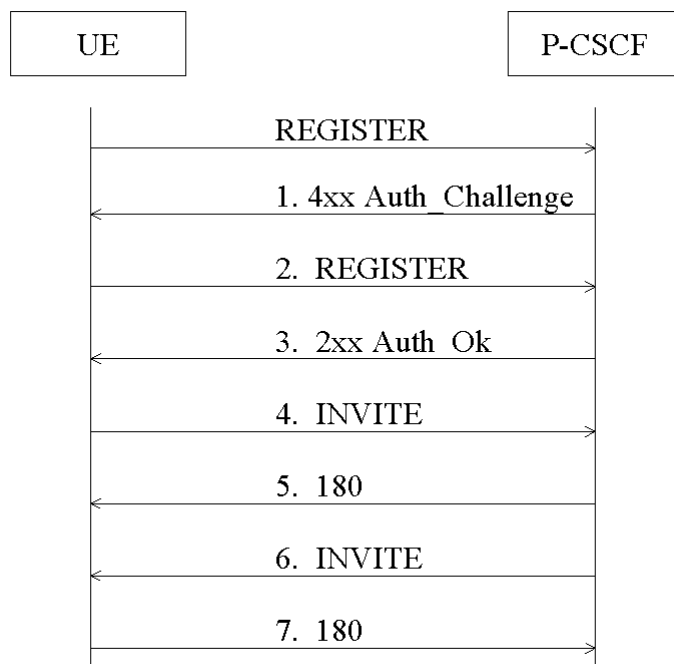

- 1. 4xx response – this carries both the IMS AKA challenge (from the registrar) and the Digest challenge for integrity protection (from the P-CSCF):**

SIP/2.0 4xx Auth\_Challenge

WWW-Authenticate: EAP <RAND AUTN>

Proxy-Authenticate: Digest realm=3GPP-IMS nonce=<random-number> algorithm=MD5 qop=extended-int

- 2. Integrity protection is turned on with the next REGISTER – the integrity credentials are placed in the Digest response:**

REGISTER sip: ... SIP/2.0

Authorization: EAP <RES>

Proxy-Authorization: Digest username=ims-user, realm=3GPP-IMS, nonce=<echo-random-number>, uri=<SIP-URI>, response=<message-digest>, cnonce=<value>, nc=1, qop=extended-int

- 3. The 2xx response is also integrity protected – the P-CSCF adds the Authentication-Info header to carry the message digest:**

SIP/2.0 2xx Auth\_Ok

Authentication-Info: qop=extended-int, rspauth=<message-digest>, nc=2

- 4. A subsequent INVITE request must also be integrity protected – the UE pre-emptively adds the Proxy-Authorization header:**

INVITE sip: ... SIP/2.0

Proxy-Authorization: Digest username=ims-user, realm=3GPP-IMS, nonce=<echo-random-number>, uri=<SIP-URI>, response=<message-digest>, cnonce=<value>, nc=3, qop=extended-int

**5. The 180 is integrity protected in the same fashion was the 2xx response (message #3):**

SIP/2.0 180 Ringing

Authentication-Info: qop=extended-int, rspauth=<message-digest>, nc=4

**6. An incoming INVITE must also be integrity protected – the P-CSCF adds the Integrity header, which has the same syntax as Proxy-Authorization:**

INVITE sip: ... SIP/2.0

Integrity: Digest username=ims-user, realm=3GPP-IMS, nonce=<echo-random-number>, uri=<SIP-URI>, response=<message-digest>, cnonce=<value>, nc=5, qop=extended-int

**7. The UE protects the 180 response by adding Authentication-Info:**

SIP/2.0 180 Ringing

Authentication-Info: qop=extended-int, rspauth=<message-digest>, nc=6

[Editors Note: Further details will be provided on how replay protection is accomplished. It has been identified that the scheme above needs to be enhanced since otherwise unnecessary loss of calls can occur. The reason for that is that both originating and terminating calls can occur and the counters in the P-CSCF and in the UE are not independent.]

[Editors Note: A description of the security mode setup headers shall be included in this Annex. Furthermore the message flows need to be enhanced.]

---

## Annex D (Informative): Set-up procedures for IPSec based solution

[Editors Note: If the IPSec solution is finally chosen the chapters below shall be moved into the main body of this TS in the corresponding sections.]

This chapter is based on chapter 7 and provides additional specification for the support of IPsec ESP.

### D.1 Security association parameters

The SA parameters, identifiers and attributes that shall be negotiated between UE and P-CSCF, are:

- ESP transform identifier
- Authentication (integrity) algorithm
- SPI

**Further parameters:**

- Life type: the life type is always seconds
- SA duration: the SA duration has a fixed length of  $2^{32}-1$ .
- Key length: the length of encryption and authentication (integrity) keys is 128 bits.

**Selectors:**

The security associations have to be bound to specific parameters (selectors) of the SIP flows between UE and P-CSCF, i.e. IP addresses and ports. Both sides have to use the same policy here, but since the required selectors will be known from the SIP messages, there is no need to negotiate them. The only parameter that shall be negotiated, is a port for specific unprotected SIP messages at the P-CSCF:

1. For the inbound SA at the P-CSCF (outbound for the UE) the P-CSCF shall use a fixed port. This may be port 5060 as the standard SIP port, or any other fixed port where the server accepts SIP messages from the UE. In addition, another port for specific unprotected SIP messages from the UE to the server is fixed. For the outbound SA at the P-CSCF (inbound for the UE) ANY port number shall be allowed at the P-CSCF.
2. On the UE side, the SIP UAs shall use the same port for both sending and receiving SIP signalling to the P-CSCF.
3. If there are multiple SIP UAs belonging to different ISIMs in one UE they shall use different SAs and bind them to different ports on the UE side.
4. The UE may send only the following messages to the fixed port for unprotected messages:
  - initial REGISTER message
  - REGISTER message with network authentication failure indication
  - REGISTER message with synchronization failure indication

All other messages incoming on this port must be discarded by the SIP application on the P-CSCF.

[Note: It is ffs whether case 3 can actually occur.]

For each incoming message the SIP application must verify that the correct inbound SA associated with the public ID (IMPU) given in the SIP message has been used. This shall be done by verifying that the correct source IP address and source port bound to the public ID (IMPU) of the SIP message have been used for sending the message.



## D.2 Security mode setup for IPsec ESP

This section describes how the security mode setup described in chapter 7 shall be used for negotiating ESP as protection mechanism and setting up the parameters required by ESP.

### D.2.1 General procedures specific to the ESP protection mechanism

The integrity and encryption mechanisms both have the value "esp". The fields SA\_ID\_U and SA\_ID\_P carry the SPI values to be exchanged, to identify the ESP SAs.

The P-CSCF shall use an unprotected port to be able to receive specific unprotected messages. This unprotected port has to be communicated to the UE, by using the *info* field of message SM4. This unprotected port is required, when an IPsec SA is already in place at the P-CSCF, but the UE due to any reason is not able to use this SA. In this case, the UE shall send error messages or a new REGISTER message in the clear to the P-CSCF port received in the *info* field within SM4. Otherwise at the P-CSCF side, ESP would simply drop all IP packets from the UE that fail the integrity check.

The error messages that shall be sent in the clear from the UE to the P-CSCF are these for network authentication failures (sections 7.3.1.2) and synchronization failures (section 7.3.1.3).

### D.2.2 Handling of user authentication failure

(This extends the content of chapter 7.3.1.1 and 7.3.3.3 for IPsec ESP)

In the case of a user authentication failure, the user will usually not be able to use a security association with the correct key material. Therefore, when using ESP for integrity protection and encryption, this will cause SM5 to be dropped at the P-CSCF IP(sec) layer due to a failed integrity check within ESP processing.

As SM5 will not reach the P-CSCF IMS application, the P-CSCF shall implement a timer for the authentication process. When a message is received that passes the integrity-check and successfully completes the authentication, it is immediately processed. However, if during the registration timer the P-CSCF receives packets that cannot be verified, it discards them. At the end of the registration timer, it reports an authentication failure back to the home network.

### D.2.3 Authenticated re-registration procedures specific to the ESP protection mechanism

The new security associations SA11 and SA12 shall be bound to a new port on the UE side. This new port shall be communicated by the UE in the *info* field of the first REGISTER message SM1.

---

## Annex E (Informative): Set-up procedures for SIP level based solution

[Editors Note: If the SIP level solution is chosen the chapters below shall be moved into the main body of this TS in the corresponding sections.] This chapter is based on chapter 7 and provides additional specification for the support of SIP level integrity protection].

For each incoming message the SIP application must verify that the correct inbound SA associated with the public ID (IMPU) given in the SIP message has been used.

## Annex F (Informative): Open issues in SA3 tailored to CN1

This annex contains issues that need discussion and resolution related to the work performed by SA3 and CN1. When the technical content is stable and the TS33.203 is going for approval to SA this Annex will be removed.

The issues in the issue column are issues defined by CN1 or SA3 for clarification. In the Status/Answer column the status is given.

Issue ID	Issue description	Source	Date	Answer from SA3	Status
S3#19-1	Security work for the ISC interface	S3-010404	SA3#19/July	Contribution S3-010660 was agreed and will be incorporated in TS33.210.	Closed/SA3#21/Novemb
S3#19-2	Security needed for OSA API interface between HN and 3rd party providers	S3-010404	SA3#19/July	Contribution S3-010660 was agreed and will be incorporated in TS33.210.	Closed/SA3#21/Novemb
S3#19-3	Can a call be terminated towards an IMPU that has not been registered?	S3-010404	SA3#19/July	Current understanding of SA3 is no. However this requirement should be stated by SA2 not SA3.	Closed/SA3#20/October
S3#19-4	Is it necessary to transport the KSI or similar in SIP-register messages.	S3-010404	SA3#19/July	This is FFS.	Open
S3#19-5	What SIP messages shall be authenticated?	S3-010404	SA3#19/July	(Re-)Registrations.	Closed/SA3#20/October
S3#19-6	Network hiding performed by the I-CSCF.	S3-010404	SA3#19/July	Contribution S3-010702 was agreed.	Closed/SA3#21/Novemb
S3#19-7	Questions related to session transfer.	S3-010404	SA3#19/July	SA3 has sent an LS to GSM association, S3-010383. Work has started.	Open
S3#19-8	Discrepancy in time plans between CN1 and SA3	S3-010404	SA3#19/July	TS33.203 shall be ready March 2002.	Closed/SA3#20/October
S3#19-9	What is the due date for the WI on hiding?	S3-010339	SA3#19/July	Included in TS33.203 section 6.4. The TS stage 2 will be ready March 2002.	Closed/SA3#20/October
S3#19-10	Should the system be able to authenticate e.g. INVITEs and not be bound to the Registration procedure?	S3-010339	SA3#19/July	Authentication shall only take place at (re-)registrations	Closed/SA3#20/October

S3#19-11	At what layer does encryption take place?	S3-010339	SA3#19/July	Encryption is optional to implement. If used it shall be at the same layer as integrity protection. It is still open if SIP-level or IP-level.	Closed/SA3#20/October
S3#19-12	Hiding the callers IP-address: anonymity	S3-010339	SA3#19/July	It was concluded that this should not be for R'5.	Closed/SA3#21/Novemb
S3#21-1	According to CN1 requirement to generalize the flows e.g. 401(vs 407 discussion) and 403 have been changed to 4xx. SA3 wants to take part of the decision on which response shall be chosen.	S3-010410	SA3#20/October	For further study	Open
S3#21-2	How is IK and optionally CK transported?	S3-010644	SA3#21/November	An LS was sent at SA3#21 to CN1 in S3-010699	Open

## Annex X (informative): Change history

Change history							
Date	TSG #	TSG Doc.	CR	Rev	Subject/Comment	Old	New
2000-10	SA3#15bis	33.2xx		0.1.0	Initial version of the specification		
2000-11	SA3#16			0.1.1	Input from AdHoc meeting		
2001-03	SA3#17	33.203		0.2.0	Input from the SA3#17 meeting in Göteborg		
2001-04		33.203		0.2.1	Termination of confidentiality in the P-CSCF moved to an editors note. Kept the R'99 mechanism in the main document. Where to terminate is FFS.		
2001-05	SA3#17bis	33.203		0.3.0	Input from the SA3#17bis meeting in Madrid.		
2001-06	SA3#18	33.203		0.4.0	Input from the SA3#18 meeting in Phoenix.		
2001-08	SA3#19	33.203		0.5.0	Input from the SA3#19 meeting in Newbury.		
2001-09	SA3#19bis	33.203		0.6.0	Input from the SA3#19bis meeting in Nice		
2001-11	SA3#20	33.203		0.7.0	Input from the SA3#20 meeting in Sydney		
2001-12	SA3#21	33.203		0.8.0	Input from the SA3#21 meeting in Sophia Antipolis		
2001-12	EmailApproval	33.203		0.8.1	Editorial comments on v.080 included		
2001-12	-	33.203		1.0.0	Updated only the version of the doc from 081 to 100, the TOC and added this text. <b>For presentation to TSG SA#14 for information.</b>		
Editor Krister Boman, Ericsson Email: <a href="mailto:krister.boman@emw.ericsson.se">krister.boman@emw.ericsson.se</a> Telephone: +46 31 747 6045 (Office) +46 70 987 6045 (Mobile)							