

Presentation of Specification to TSG or WG

Presentation to: TSG SA Meeting # 13
Document for presentation: TR 22.944, Version 1.0.0 on UE Functionality Split
Presented for: Information

Abstract of document:

This report identifies scenarios and requirements for UEs with functionality split over multiple devices. Scenarios that are required to be supported in the standard are defined in detail.

This report is not intended to identify all possible or permitted functionality splits. However it is intended to identify a minimum set of scenarios which shall be supported in the standard.

Certain splits of functionality may be prohibited for security or other reasons. This report does not identify all prohibited scenarios. However requirements stated here may implicitly prohibit some scenarios.

Changes since last presentation:

Not previously presented.

Outstanding Issues:

TE-MT split and speech codecs:

Some issues raised by T2 with header removal and it's impact on UE functionality split work. This has been raised in the joint ad hoc in Cancun. Expected completion date is February 2002.

There is also a possible issue with the delivery of speech to the codec.

Contentious Issues:

None at this time.



**3rd Generation Partners
Technical Specification Group Services and System
Aspects;
Report on Service Requirements for UE Functionality Split;
(Release 5)**

The present document has been developed within the 3rd Generation Partnership Project (3GPP™) and may be further elaborated for the purposes of 3GPP.

The present document has not been subject to any approval process by the 3GPP Organizational Partners and shall not be implemented.

This Specification is provided for future development work within 3GPP only. The Organizational Partners accept no liability for any use of this Specification.

~~Specifications and reports for implementation of the 3GPP™ system should be obtained via the 3GPP Organizational Partners' Publications Offices~~

Keywords

<keyword[, keyword]>

3GPP

Postal address

3GPP support office address

650 Route des Lucioles - Sophia Antipolis
Valbonne - FRANCE
Tel.: +33 4 92 94 42 00 Fax: +33 4 93 65 47 16

Internet

<http://www.3gpp.org>

Copyright Notification

No part may be reproduced except as authorized by written permission.
The copyright and the foregoing restriction extend to reproduction in all media.

© 2001, 3GPP Organizational Partners (ARIB, CWTS, ETSI, T1, TTA, TTC).
All rights reserved.

Contents

Foreword Introduction	5
1 Scope	6
2 References	6
3 Definitions, symbols and abbreviations.....	6
3.1 Definitions.....	6
3.2 Abbreviations	7
4 General Aspects.....	7
4.1 Overview of User Equipment.....	7
4.2 Background to Requirements	7
4.3 Assumptions	8
5 Possible Scenarios	8
5.1 Scenario 1.....	8
6 Requirements.....	9
6.1 General	9
6.2 Security	10
6.3 Functionality split.....	10
6.3.1 MT Functions	10
6.3.2 TE Functions	10
7 Conclusions	10
Annex A: Example Scenarios	11
Annex B: Scenarios for possible functionality split for the Circuit domain.....	13
Annex C: Change history	17

Foreword Introduction

The future environment will be characterised by features such as multimedia services and the convergence of 3GPP systems and the Internet. In this environment the total User Equipment used to access 3GPP services may be implemented over a number of physical devices. For example the User Equipment may include a PC or PDA with appropriate client software as well as a separate module containing radio protocols and other elements. These cases are referred to under the term “UE Functionality Split” or just “UE Split”.

This report identifies scenarios and requirements for UE Functionality Split.

1 Scope

This report identifies scenarios and requirements for UEs with functionality split over multiple devices. Scenarios that are required to be supported in the standard are defined in detail. For the scenarios in this report the 3GPP standard shall enable interoperability between user equipment components from different vendors. This report is not intended to identify all possible or permitted functionality splits. However it is intended to identify a minimum set of scenarios which shall be supported in the standard.

Certain splits of functionality may be prohibited for security or other reasons. This report does not identify all prohibited scenarios. However requirements stated here may implicitly prohibit some scenarios.

2 References

The following documents contain provisions which, through reference in this text, constitute provisions of the present document.

The following documents contain provisions which, through reference in this text, constitute provisions of the present document.

- References are either specific (identified by date of publication, edition number, version number, etc.) or non-specific.
- For a specific reference, subsequent revisions do not apply.
- For a non-specific reference, the latest version applies. In the case of a reference to a 3GPP document (including a GSM document), a non-specific reference implicitly refers to the latest version of that document *in the same Release as the present document*.

- [1] 3GPP TS 21.905: 3rd Generation Partnership Project; Technical Specification Group Services and System Aspects; Vocabulary for 3GPP Specifications.
- [2] 3GPP TS 22.060: 3rd Generation Partnership Project; Technical Specification Group Services and System Aspects; General Packet Radio Service (GPRS); Service Description, Stage 1
- [3] 3GPP TS 22.228: 3rd Generation Partnership Project; Technical Specification Group Services and System Aspects; Service Requirements for the IP Multimedia; Core Network Subsystem (Stage 1)
- [4] 23.101 General UMTS Architecture
- [5] 24.002 GSM-UMTS Public Land Mobile Network (PLMN) access reference configuration

3 Definitions, symbols and abbreviations

3.1 Definitions

User Equipment Combination: All the user equipment that is connected and used together in a particular scenario. For example a user equipment combination may consist of an MT and all the TEs that are connected to that MT.

User Equipment Component: Any one of a number of separate components of user equipment. User equipment components include MTs and TEs.

[Editors note: Other terms e.g. MT, TE should be defined in 21.905. However the current definitions may not be sufficiently clear for a detailed discussion of UE-split. The current definitions date back to ISDN models from the 1980s.]

3.2 Abbreviations

For the purposes of the present document, the following abbreviations apply:

MT	Mobile Terminal
PC	Personal Computer
PDA	Personal Digital Assistant
TE	Terminal Equipment
UE	User Equipment

[Editors note: Complete list is to be provided]

4 General Aspects

4.1 Overview of User Equipment

3GPP user equipment may take many forms. One case is that all the user equipment is integrated in to a single physical device. This report deals with cases where several different components make up the whole user equipment combination. An example is illustrated below. This illustration is only meant to introduce concepts and not imply any limitations or physical form for user equipment.

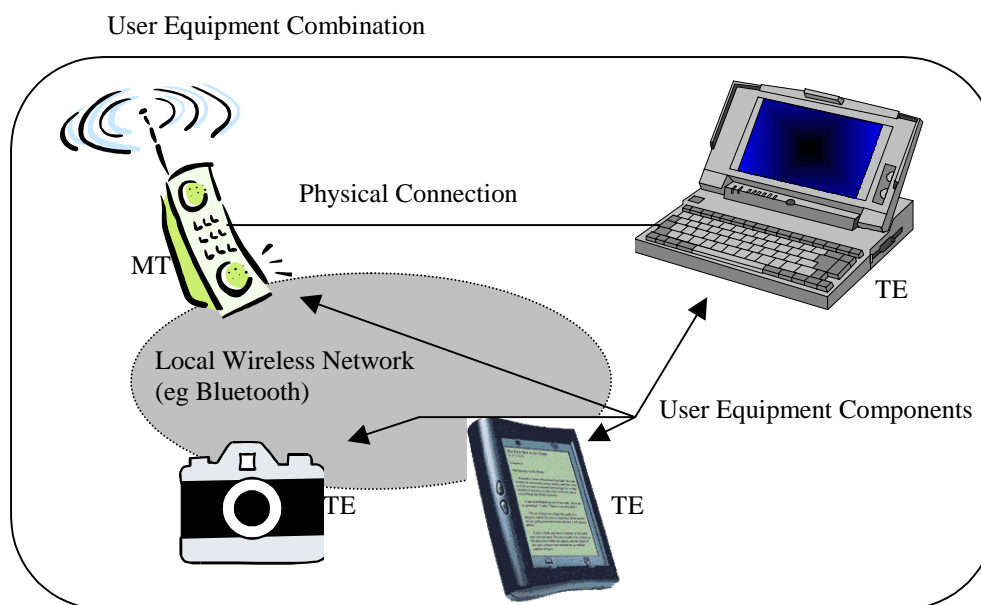

The user equipment combination shall contain at least one MT and may also contain one or more TEs.

4.2 Background to Requirements

The support of UE-functionality split in 3GPP should aim to exploit technology trends and to promote the convergence of 3GPP technologies with Internet and computing technologies. The objective of this report is to identify a small number of scenarios which are seen as being particularly important for the success of the 3GPP system. These scenarios should:

- correspond to likely physical scenarios for available equipment
- offer attractive commercial opportunities
- be simple enough to allow requirements capture and technical specifications to be completed
- align with other standards (e.g. Bluetooth, PC-Card) and common industry practice (e.g. major operating systems) where appropriate

Allowing some 3GPP related applications to be implemented on TEs separate from the MT offers advantages such as:

- Ability for applications to evolve without changing hardware or firmware. This will improve service velocity.
- Ability of 3GPP applications to integrate with a user's other business, entertainment and communications tools.
- Allowing 3GPP applications to take advantage of the physical characteristics of computer (e.g. large display, memory, processing power)
- Ability to use hardware built into the TE (eg speaker, microphone) for input and output.
- Integration of emerging wireless LAN technologies (e.g. Bluetooth, 802.11b) with 3GPP networks

4.3 Assumptions

In identifying the requirements and scenarios for UE-split functionality, the following assumptions are made:

- a The transport link between the TE and MT functions of the UE is not necessarily secure.
- b A USIM application resident on a UICC is required to access the 3G network. Only a single USIM on a UICC can be active at any time (multiple USIMs can be located on a UICC).
- c Charging is linked to one particular USIM.
- d The secret key and the authentication algorithm cannot be transferred out from the USIM.
- e The SIM/USIM must be present during the entire duration of the call. Periodic UICC presence detection is mandatory during a call.

5 Possible Scenarios

The following scenarios have been found to be interesting and relevant. The Appendix A lists scenarios that were discussed and either found to be (a) enabled by one or more of the scenarios listed in this Chapter or (b) not relevant or (c) not possible to support given the current system architecture.

5.1 Scenario 1

In this case, multiple independent applications that are possibly being used by independent users employ one subscription and its information is stored in one SIM/USIM/ as shown in Fig. 1. The user(s) identity is possibly different from the subscribers' identity.

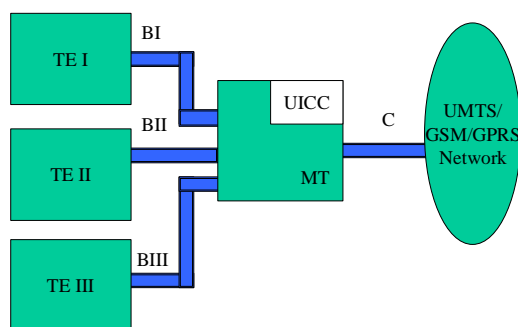

Figure 1: Multiple applications and/or users with one subscriber identity.

Note: The single TE associated with a single MT scenario is a special case of this scenario.

Examples of where scenario 1 is useful include:

- A PC or PDA contains a 3GPP defined radio module to allow it to access 3GPP services. The module may be a (semi)permanent part of the PC or PDA (similar to an embedded modem) or a removable module such as a PC card.
- A 3GPP defined radio module provides access to multiple computing/communication resources in a local environment (for instance, a camera, a computer, phone).

[Editor's Note: The following seems more appropriate for a stage 2 description. It is recommended that this be incorporated into an appropriate document at a later stage.]

The functionality split required in this case corresponds to generic way computers treat other types of network interface cards. In this configuration the basic 3GPP protocols are implemented in the 3GPP defined radio module (see figure below). The computer contains the following elements:

- driver software to control the 3GPP radio module and interface it to the computer operating system
- software applications using network protocols (such as IP) which are routed to other computers via the card.

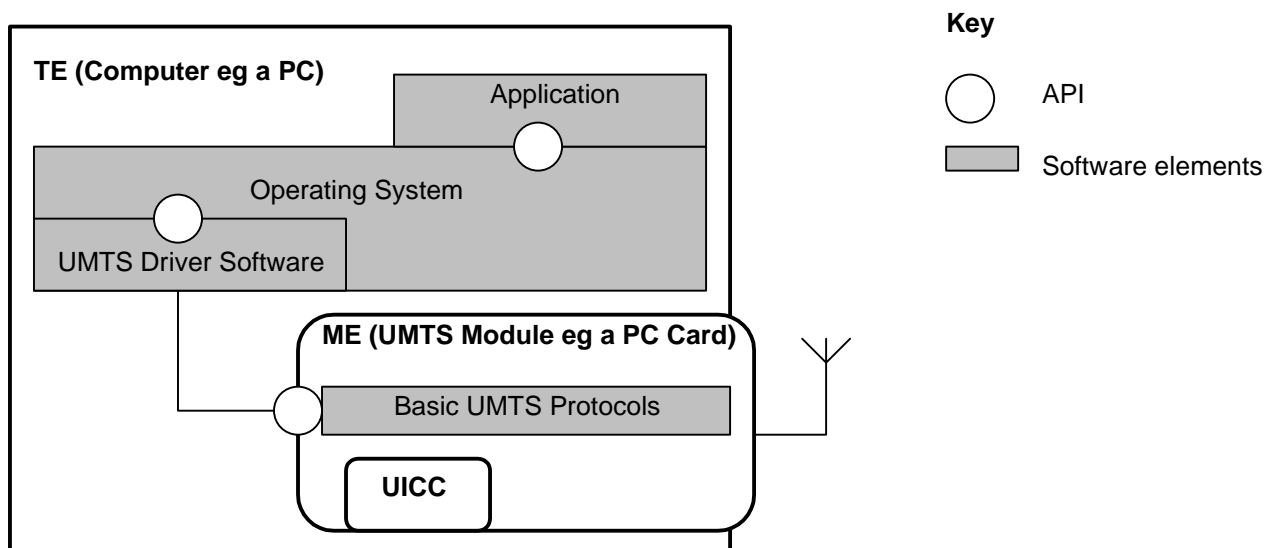

6 Requirements

Requirements are identified for only the single active subscription for each TE-MT combination case. Requirements for the other more general cases may be added in later releases.

6.1 General

- 1 The functionality split proposed shall apply to Circuit Switched (CS) domain.
- 2 The functionality split proposed shall apply to the Packet Switched (PS) domain.
- 3 The user shall be able to control which MTs and TEs are part of their user equipment combination.
- 4 A generic way of describing an API for access to capabilities provided by an MT (TE) towards a TE (MT) across Operating Systems must be provided.

- 5 It shall be possible to develop applications in the TE that use 3GPP services independently of the specific 3GPP defined radio module being used. For example the application developer should not need to write different applications for 3GPP defined radio modules made by different companies.
- 6 Control over radio aspects, other than the functionality available today with AT commands should not be provided to the TE.
- 7 Call control signalling (e.g. IMS SIP signalling) must not be run transparently through the MT by the TE in this Release.

6.2 Security

MEI shall be collocated with Mobility Management functions.

Note: Given that Mobility management function (see section 6.3.1) must be located on the MT all relevant security-related identities (IMEI, IMSI, TMSI, etc.) must be located on the MT.

6.3 Functionality split

The MT shall contain at a minimum, a set of 3GPP protocols which assure system integrity and security.

- a The USIM/SIM application is part of the MT.

The application environment in the TE may need to be extended to support any required 3GPP-specific elements (eg communication between the application and the UICC).

6.3.1 MT Functions

- 1 Radio attachment to the 3GPP network.
- 2 Authenticating subscription(s) (including IMS subscription).
- 3 Communicating with the UICC & SIM/USIM on behalf of the TE.
- 4 Creation/activation/deactivation of additional PDP contexts on demand from a TE.
- 5 Transceiving PS data across the appropriate Radio Access Bearers with the RAN
- 6 Security
- 7 Call control (including call control for IMS)
- 8 Mobility Management function
- 9 Storing IMEI

6.3.2 TE Functions

- 1 Control of hardware in the TE (speaker, microphones, video cameras, displays, etc.)
- 2 Access services and capabilities provided by the MT.

7 Conclusions

The scenarios identified in clause 5 and the requirements identified in clause 6 shall be supported in 3GPP.

It is important that access is not given freely to any parts of the network by unauthorised software entities and therefore it is recommend that the interface between a TE and an MT uses the 27.007 and 27.005 AT command set.

Annex A: Example Scenarios

Scenario 2

In this case, multiple SIM/USIM applications are stored on the MT on a single UICC. Each application (that may be associated with its own unique user) has its own unique SIM/USIM associated with it. The billing is associated with the subscriber's identity stored in the SIM/USIM.

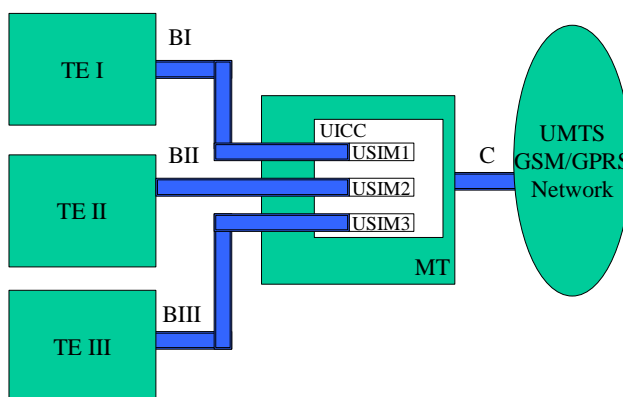

Figure 2 - Multiple users, multiple “borrowed” subscriber identities.

Editors Note: Release 99 allows multiple USIMs stored to be stored on a UICC but they cannot be all active at the same time. In Release 4, the support of logical channels on the UICC enables multiple USIM activation. However, for any registered UICC it is assumed that only one SIM/USIM can be active at any given time.

The scenarios discussed above can be divided into two categories based on the number of simultaneously active subscriptions per user equipment configuration. Scenario 1 and Scenario 2 are examples of cases where there is a single active subscription per UE. This implies that for these scenarios:

- 1) The user equipment combination shall contain only one active SIM/USIM.
- 2) The user equipment combination shall contain only one active MT.
- 3) All MTs and TEs in a particular user equipment combination shall be treated by the 3GPP system as being under the responsibility of the subscription identified by the active SIM/USIM. All charges made by 3GPP shall be directed to the subscriber identified by the SIM/USIM.

Note: It is possible that charges that are not related to the 3GPP subscription may be treated differently for different TEs in the same user equipment combination. For example a user on a TE may access an Internet service which charges them based on a credit-card or a subscription that is not associated with 3GPP.

Note: If a 3GPP subscriber permits a TE to be connected to their user equipment combination they shall be willing to accept any charges as a result of this. This is similar to the situation where you lend your phone to another person to allow them to make a call.

Scenario 3

In this case, every user uses subscription per device and each device (e.g. PC, PDA) have a UICC. The MT does not use an UICC, even if an UICC is physically present. In this case, each TE is independent and billed for separately. The MT in this case is used as transmitter with multiplexing capabilities and the CK and the IK are handled by the TEs

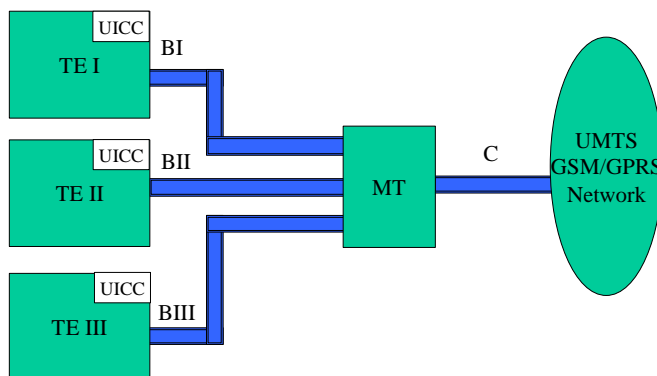

Figure 3 - Multiple users, multiple “owned” subscriber identities.

Due to security concerns this case is not possible, since USIM/SIM applications must be collocated with the Mobility Management on the MT. (It is assumed that the Mobility Management functions are located on the MT).

Scenario 4

In this scenario, every user has a subscription i.e. each user has one UICC that resides in a device (TE + MT) such as the mobile phone (like in case 3). However, the user may be able to transition (henceforth, handoff) into using a different MT (which has a UICC with a SIM/USIM application resident) as shown in the figure below.

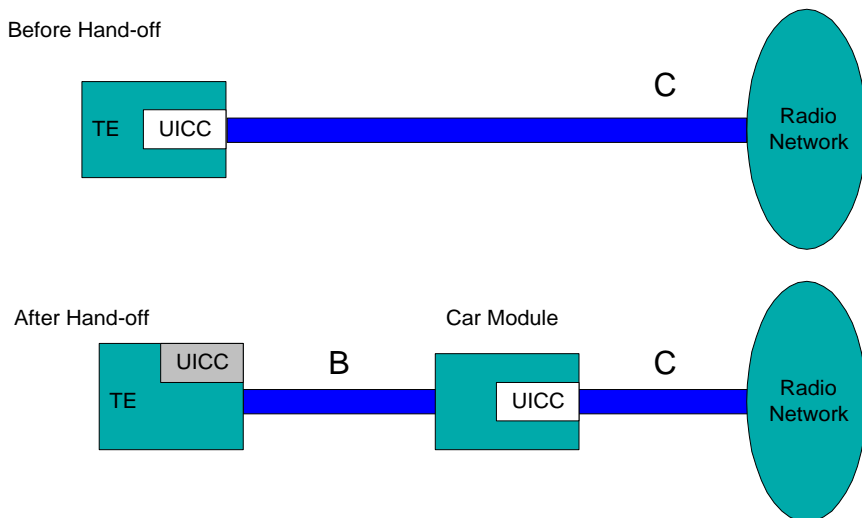

Figure 3: Hand-off to a “borrowed” subscriber identity.

Comments: Hand-off during “IDLE” state may be possible for CS/PS domains using existing services offered by each domain. Significant issues arise if this must be accomplished during “active” state. The assumption is that the handoff is accomplished using existing supplementary services (call forwarding, explicit call transfer etc). This is under the assumption that after the handoff the functional split will be the same as the TE and MT split case discussed earlier.

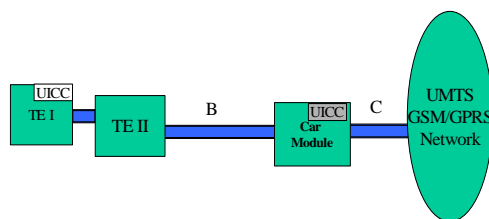

Figure 4: Hand-off, but retain and lend “own” subscriber identity.

In a variation of the scenario under consideration, it may conceivably be possible to use the UICC on the TE while using a borrowed MT. However, this is not possible since the USIM/SIM application and the MM function should be collocated and on the MT.

Annex B: Scenarios for possible functionality split for the Circuit domain

This annex identifies scenarios for possible functionality split for the Circuit domain. It is expected that these scenarios will aid in deciding the functionality splits to be supported. Note that the scenarios enumerated here may not be exhaustive yet and others may be added.

B.1 Telephony

This section deals with circuit-switched voice Telephony (TS11).

B.1.1 Functional Elements

The following functional elements are identified as being applicable to the Telephony service:

B.1.1.1 Call Control and Mobility Management (CC&MM)

The Call Control and Mobility Management entity is a C-plane function which supports the signalling for call control and mobility management. The actions of the CC&MM may be initiated directly by the user using a local HMI, or by a Call Control Client on a remote device.

B.1.1.2 Call Control Client (CCC)

The Call Control Client is a client that interfaces to the CC&MM to provide service. The protocol between the CCC and the CC&MM is an intermediate protocol that allows the CCC to signal its call setup and release requirements.

B.1.1.3 Codec

The codec is a U-plane entity responsible for applying the radio-interface voice coding to a PCM or analogue signal.

B.1.1.4 Transducer

The transducer is a U-plane entity responsible for converting between physical sound waves and electrical signals.

B.1.1.5 Radio Resource Layers (RR)

The Radio Resource Layers cover the C-plane and the U-plane. They are responsible for all low-level protocols on the radio interface – including the MAC and physical layers.

B.1.2 Telephony Scenarios

B.1.2.1 Telephony Scenario 1 - Headsets

Telephony scenario 1 corresponds to the use of a headset to access the telephony service. Though a headset is not normally considered to be a TE, from a formal point of view it is an external device connected to the MT and therefore should strictly be included in the discussion. As the question of support for wireless headsets has frequently been mentioned in conjunction with UE-split it is felt necessary to include this scenario for completeness. The model presented is applicable to both wired and wireless headsets.

In Telephony Scenario 1 the TE only contains the transducer. All other functions are included in the MT.

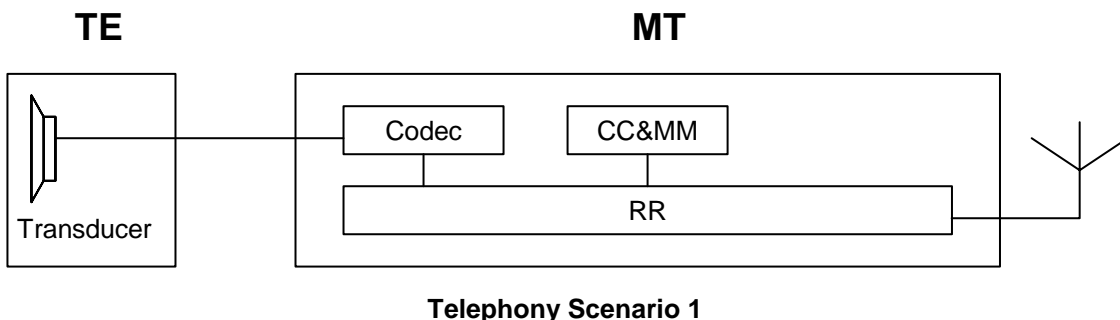

B.1.2.2 Telephony Scenario 2 – Telephony Control Application in TE

This scenario corresponds to the use of a TE (a PC or a PDA) which contains a function to control telephony calls on behalf of the user. This might be a telephone dialler application linked to a contacts database. APIs like “TAPI” are typically used to provide this interface to applications. On the R-interface the AT-command set provides some of the required functionality. In this scenario the user’s voice is still handled only in the MT.

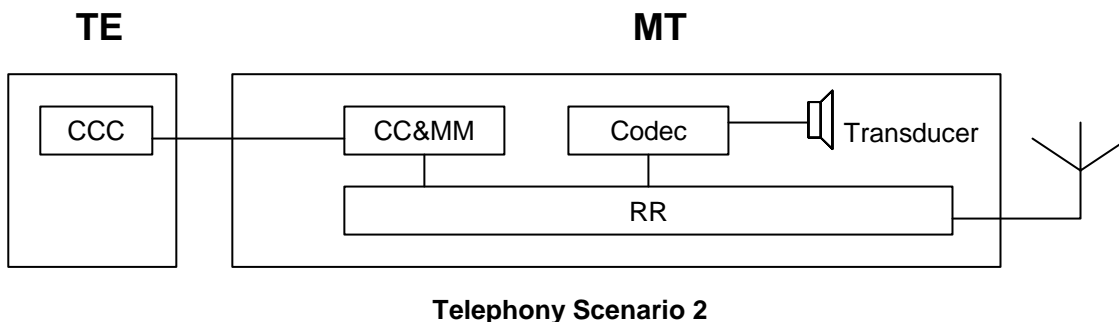

B.1.2.3 Telephony Scenario 3 – Telephony Supported in TE

In this scenario the HMI for the Telephony teleservice is supported in the TE. This may correspond to a user who uses their PC or PDA to initiate calls (the above scenario), but also wants to multiplex the audio component of their calls on to their PCs sound-channel so they can also use the PC’s MP3 or CD player via the same transducer.

The U-plane interface between the TE and the MT is assumed to be PCM or a similar light-weight encoding.

NOTE: This scenario raises the interesting question of TE-split! In this case it is likely the transducer is not physically integrated with the TE, but is in fact a headset connected to the TE. At this level of modelling it is assumed that the internal structure of the TE (even if it is itself made up of several components) is not important provided this doesn’t change the TE-MT interface.

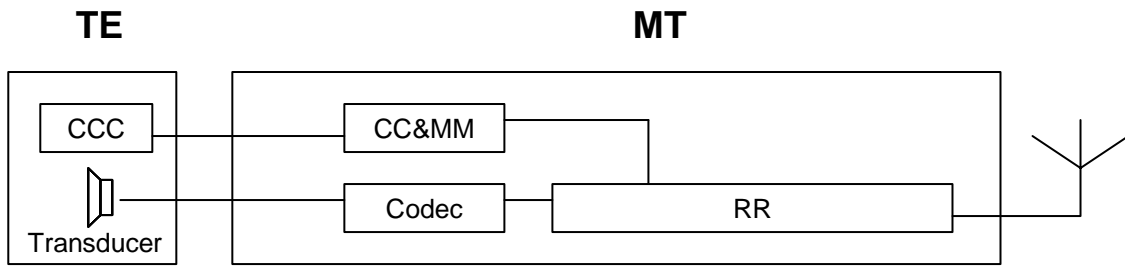

Telephony Scenario 3

B.2 Circuit Bearer Services

This section deals with the circuit-mode data bearer services

B.2.1 Functional Elements

The following functional elements are identified as being applicable to the Circuit Bearer Services:

B.2.1.1 Call Control and Mobility Management (CC&MM)

As for telephony.

B.2.1.2 Call Control Client (CCC)

As for Telephony

B.2.1.3 Terminal Adaptation Function (TAF)

The TAF maps the data format on the R-interface in to the format needed for the bearer.

B.2.1.4 Data Termination (DT)

The data termination is the end-point in the user-equipment for the bearer service. The DT is outside the scope of the 3GPP standard.

B.2.1.5 Radio Resource Layers (RR)

As for Telephony

B.2.2 Circuit Bearer Scenarios

B.2.2.1 Circuit Bearer Scenario 1 – PC or PDA Access

This scenario corresponds to a PC or PDA that uses the circuit bearer service. This scenario is supported by the existing R-interface standards.

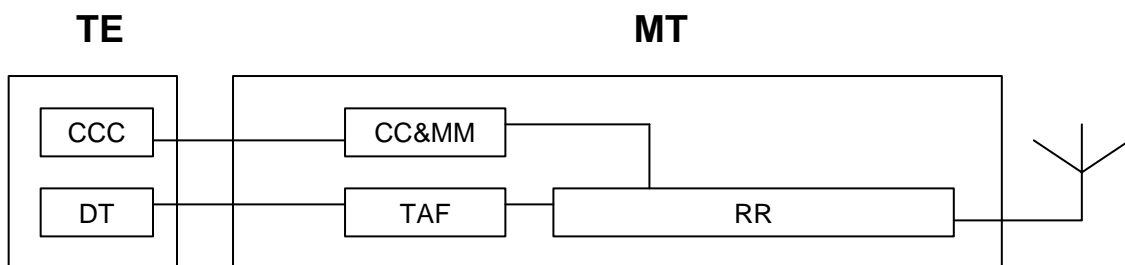

Circuit Bearer Scenario 1

B.4. Packet-Based Data Scenarios

This scenario deals with packet-based data services using the capabilities of the PS-domain. It does not deal with the release 5 IMS (which is covered in a separate paper).

B.4.1 Functional Elements

B.4.1.1 Session Management and Mobility Management (SM &MM)

The Session Management and Mobility Management entity is a C-plane function which supports the signalling for session management and mobility management. Session management includes the establishment, management and release of PDP contexts. The actions of the SM&MM may be initiated directly by the user using a local HMI, or by a Session Management Client on a remote device.

B.4.1.2 Session Management Client (SMC)

The Session Management Client is a client that interfaces to the SM&MM to provide service. The protocol between the SMC and the SM&MM is an intermediate protocol that allows the SMC to signal its session setup and release requirements.

B.4.1.3 IP Adaptation Function (IPAF)

The IPAF is a U-plane function that does the high-level mapping of IP data in to the UMTS bearer.

B.4.1.4 IP Data Termination (IPDT)

The IP Data Termination is the end-point in the user-equipment for the IP bearer service provided by the PS-domain. The IPDT is the entity addressed by the IP address assigned at the user level to the primary PDP context.

B.4.1.5 Radio Resource Layers (RR)

As for telephony.

B.4.2 Packet-Based Data Scenarios

B.4.2.1 Packed-Based Data Scenario 1 – PC or PDA Access

This scenario corresponds to a PC or PDA that uses the packet bearer service. This scenario is partially supported by the existing R-interface standards.

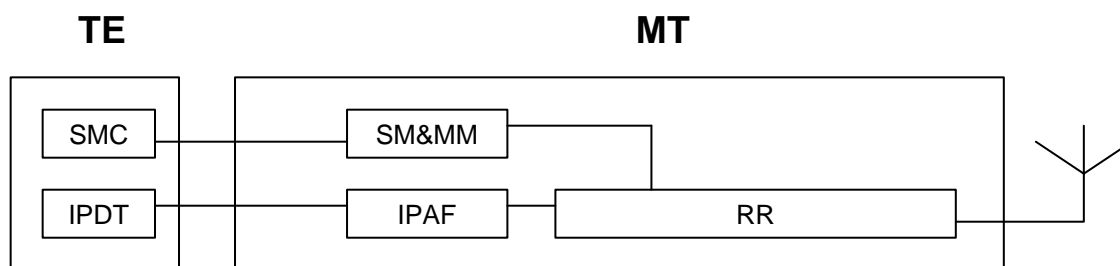

Packet Based Data Scenario

Annex C: Change history

Change history								
Date	TSG #	TSG Doc.	CR	Rev	Subject/Comment	Old	New	
10/08/01					Initial draft		0.0.0	
5/09/01					Revised at the joint T2-S1 meeting		0.0.1	
13/09/01					Addition of Appendix B, agreed at the joint T2-S1 meeting		0.0.2	
31/10/01					Editorial corrections		0.0.3	
07/11/01					Discussion at TSG S1 # 14 UE-split adhoc		0.5.0	
09/11/01					Raised to version 1.0.0 for presentation to SA #14		1.0.0	

--	--	--	--	--	--	--	--