

Title: Report from LCS Workshop, London, UK, 11-12  
Source: QUALCOMM Europe SARL  
Date: 19 March 2001  
Status: For information

## 1 Opening

The chairman, Armin Toepfer (Mannesmann Mobilfunk) explained the background to the workshop, saying that it was set up by TSG-SA#10. See SP-000677.

The workshop was, despite low number of registrations, very well attended: 76 participants.

Due to the absence of anyone from ETSI MCC, David Williams (Qualcomm) and Kirk Burroughs (Qualcomm) volunteered to do the meeting report jointly. The meeting agreed.

## 2 Registration of Documents and approval of agenda

The agenda in **Tdoc 1** was agreed but with the addition of a new item 2 "Registration of Documents and approval of agenda" and with the addition under item 6 (new numbering) "What are the requirements in terms of functions outside of the existing nodes". This report is based on the structure of the revised agenda.

## 3 GSM LCS Overview

### a. Service Level Requirements

**Tdoc 15** from the SA1 vice chairman Randolph Wohlert (SBC) was presented by Brendan Ludden (Vodafone). It gives an overview of TS 22.071. The intent of this presentation was to provide an overview of the Stage 1 requirements for LCS. Although the presentation was only for 3GPP, it was discussed in the context of both GSM and 3GPP (GSM 02.71 and TS 22.22.071) as service requirements could be considered as system independent.

It was pointed out that it could be beneficial to go through requirements and see what is achievable at what point of time. Others pointed out that the requirements should not be phased but rather that implementations should be phased. It was suggest that SA1 should consider providing some prioritization, but no explicit action was taken.

### b. Architecture

**Tdoc 3** was presented by Kirk Burroughs (Qualcomm). It gives an overview of the GSM LCS specifications. Specifically it gives a detailed overview of the network reference model, the interfaces and protocols and, the call flows as they pertain to MS-Assisted and MS-Based Assisted GPS. While the presentation focused on A-GPS, other than the RRLP level call flows; it is equally relevant to E-OTD. Lastly the presentation showed the details of the open interface between the NSS/BBS and the SMLC highlighting the low number of messages and parameters.

**Tdoc 19** was presented by Yillin Zhao (Motorola) giving a further overall overview of LCS standards work.

**Tdoc 14** was presented by Margaret Livingston (Nokia). It gives an overview of LCS standardization activities in 3GPP TSG GERAN. It was noted that a stand-alone SMLC was supported in GERAN. GERAN LCS is concerned with changes to the overall LCS architecture for Release 4. There are two major projects ongoing within GERAN; LCS support in GRPS and the Lu interface.

#### Discussion

Cell id and timing advance still under study in GERAN LCS.

#### **c. Positioning Technologies**

**Cell Sector + TA – No presentation was given.**

**TOA – No presentation was given.**

**EOTD – No presentation was given.**

#### **GPS**

**Tdoc 4** was presented by Len Sheynblat (Qualcomm). It describes wireless assisted GPS which offers benefits of faster time to radio-locate, higher signal sensitivity and better performance in hostile environments. Performance is measured by location accuracy and service availability (yield).

#### Discussion

- Discussion about what is mandatory in the network and MS. clarified that everything is optional.
- Can a roaming subscriber take roaming assistance data from home or visited network? How is charging handled?
- For roaming the home and visiting networks must support assisted GPS
- Clarified that there are different types of assistance data, which are valid for different periods of time.
- In practice there will be different SLMCs for each network. Roaming not an issue - different quality of service in each network.

## **4 3GPP LCS Overview**

### **a. Service Level Requirements – Addressed by agenda item 3a.**

### **b. Architecture**

#### **LCS System Aspects GERAN**

**Tdoc 17** was presented by Jan Kall (Nokia) giving a quick overview of the current LCS architecture in UMTS and opened the discussion on the topic of a stand alone SMLC. It illustrates benefits of integrating the SMLC functionality in the SRNC and offers arguments against the NSS based SMLC within 3GPP. This document also offers arguments for a BSS based SMLC within 3GPP. The paper suggests that the SMLC could be separated from the SRNC in several ways and further study is needed to find the optimum solutions.

#### Discussion

- Only low chip rate TDD planning to use position information for handover.
- Discussion of beam forming techniques.
- Why position information not available to radio access network?

- Service continuity going from GSM to UMTS is essential.
- Different approach in Release 4 and Release 5 may be undesirable.
- The issue of backwards compatibility with GSM LCS service is important.

### **LCS System Aspects UTRAN**

**Tdoc 21** was presented by Mark Beckmann (Siemens). It is an overview of work in TSG RAN WG2 on UE positioning.

#### **c. Positioning Technologies**

**Cell Sector + RTT- No Presentation was given.**

**OTDOA – No Presentation was given.**

**Tdoc 18** from Panasonic gives an overview of Observed Time Difference of Arrival utilizing Position Elements method. First introduced to RAN WG2 in R2-001718. It was presented for information.

#### Discussion

- Several PEs are required per base station.
- Need to assess the load and impact on the network capacity.
- Further study is required.

**GPS – Covered under agenda item 3c.**

### **5 Comparison of LCS Architectures and Options between GSM LCS and 3GPP**

#### **a. White Papers (S1-LCS000015, S2-001440)**

**Tdoc 6 and Tdoc 7** were presented by Kirk Burroughs (Qualcomm). They describe changes that have occurred to the LCS specifications as they have migrated from GSM to UMTS. Concerns were raised that flexibility has been reduced and that restorative actions are required. The concerns can be categorized as follows:

- Open interface within the UTRAN between the SMLC and SRNC
- CN based SMLCs
- CBC interaction with LCS

#### Discussion

- RAN / CN separation decision has been in place for some time and CN based SMLC are difficult to pursue.
- Which radio location technologies were considered when the decision was made in 1997 for closed interface? None – considerations only at architectural level.
- In 1997 GPS measurements were not envisaged.
- Multiple arguments were given for the pros and cons between a stand alone SMLC and an integrated SMLC.

**Tdoc 16** was presented by Tomas Brannlund (Ericsson). Ericsson does not support LCS open interfaces because it adds complexity and may introduce delays. Calls flows were presented that show the signaling on the new interface would be unnecessarily complex. Ericsson proposed that three options were available: Options are:

1. Keep current architecture
2. intelligence in SMLC

### 3. non-intelligent SMLC.

#### Discussion

- The SRNC-SMLC interface described in the contribution was supported by some companies.
- It was pointed out that the call flows described were unduly complicated and that it should be possible to create an open face much like in GSM LCS today, i.e. 4 flows only.
- Solution with minimum impact on RNC development desirable. Assisted GPS on non-integrated SMLC seems desirable.
- Some suppliers seem to be complicating the issue. Open interface needed. Supports previous comment.
- LCS services will need a separate evolution path then the RNC and separation is a sound idea.
- The types of data exchanged over a private interface is the same as the type of date exchanged over an open interface.
- Should investigate stand alone SMLC but not jeopardize standardization and implementation work.
- Open interface necessary in Release 4
- Assisted GPS is defined in TS 25.331

#### **b. Liaison Statements (GSM NA, GSMA, SA1, and SA2)**

**Tdoc 8** is the work item that was agreed in TSG-SA.

**Tdoc 9** is a liaison statement from GSM North America requesting open interfaces for SMLC.

#### **c. Work Items (SA1 and SA2)**

**Tdoc 5** is a new work item to concentrate on open interfaces in Release 4. It was withdrawn and later on replaced by Tdoc 22 which is the outcome of discussion (see below).

#### **6 Work Areas:**

Identify comparable open interfaces and protocols in UMTS and GERAN which correspondent to GSM LCS interfaces and protocols

**Tdoc 20** was presented by Denis Fauconnier (Nortel Networks). It addresses the support of LCS in GERAN Release 4 in lu mode.

#### Discussion

- GERAN is closer to UTRAN than GSM in terms of BSS functionality
- **Working assumption** - keep logical split. SMLC independent entity but part of RAN.

**Tdoc 2** was presented by Rick Bailey (Orange). This paper emphasizes the requirements for a standalone SMLC.

#### Discussion

- Orange agrees with the working assumption above.
- Migration path issues associated with the working assumption.
- SMLC as stand alone entity could support multiple interfaces thus enabling migration.
- Interface has to be defined and this takes time.

#### **7 Path Forward**

The chairman adjourned the meeting at 6pm on Thursday and a drafting session was convened by Kirk Burroughs with the task to test the working assumption and to elaborate a proposal for a modified work item. This new work item was drafted in **Tdoc 22** and presented by Kirk Burroughs when the meeting reconvened on Friday morning.

**Tdoc 22** – This document presented a work item for RAN that addressed the issue of an open interface between the SMLC and SRNC within in the UTRAN. It was presented as a compromise position from the LCS Workshop only focusing on the UTRAN issues.

#### Discussion

- Decision taken to avoid duplication of functionality.
- There were request to keep the work item open to methods other than A-GPS, with support from multiple operators. Perhaps this can be handled as another work item at the RAN level.
- Nothing here prevents other positioning methods being used such as OTDOA.
- No other option is precluded.
- Focus on this work item and independently discuss next phases.
- Open for discussion in LCS workshops what kind of info provided to SMLC to support A-GPS.
- Concern was expressed that only supporting A-GPS in a stand alone SMLC would preclude the possibility of combining GPS with OTDOA in the future.
- A desire was expressed to allow for the support of other positioning methods in a stand alone SMLC mode.

The work item in Tdoc 22 was amended slightly with the addition of a sentence “The addition of this interface does not preclude the A-GPS to be supported in the SRNC” and other slight modifications. It was agreed that the goal of the work item is to develop the open interface for Release 4. Additional ideas may be sent to the RAN workshop on UTRAN Evolution 5-6 February. It was also agreed that the path is left open for discussions of the architectural evolutions and of other positioning methods.

**Tdoc 23** contains the final version of the work item.

#### **Result of the LCS Workshop:**

- 1. A proposal will be made to TSG-SA to withdraw the work item agreed in TSG-SA#10 in SP-000685.**
- 2. A proposal will be made to TSG RAN to endorse the new work item as described in Tdoc 23. This new WI covers R4.**
- 3. The workshop recommends to GERAN that lu mode should follow the same principle as UTRAN, but take into consideration that the final decision will be made in GERAN.**

#### **a. Overall LCS Work Item Management**

Included in the above text.

#### **b. Individual LCS Work Items**

Included in the above text.

#### **c. Refinement of LCS Open Interface Work Item**

Included in the above text.

## **8 Closing**

The chairman closed the meeting at 1115 GMT on Friday 12 January and thanked the host Vodafone.

**Annex 1: Result of the LCS Workshop – Proposed new Work Item**

Technical Specification Group Services and System Aspects  
LCS Workshop, London, UK, 11-12 January 2001

**LCS(01)0023**

**Source:** LCS Workshop  
**Title:** Work Item Description for an Open SMLC-SRNC Interface within the UTRAN to support A-GPS Positioning  
**Document for:** Approval  
**Agenda Item:** 7

**Work Item Description**

**Title: Open interface between the SMLC and the SRNC within the UTRAN to support A-GPS Positioning**

**1 3GPP Work Area**

X	Radio Access
	Core Network
	Services

**2 Linked work items**

None identified.

**3 Justification**

At the 3GPP LCS Work Shop held in London on 1/11/01 and 1/12/01 it was agreed that for A-GPS positioning, sufficient functional separation existed with RNC functions to justify the opening the interface towards a standalone SMLC.

**4 Objective**

The objective of this work item is to provide for support of an open interface between the SMLC and the SRNC within the UTRAN for the support of A-GPS positioning. This new interface would be analogous to the Lb interface defined in the GSM LCS specifications with the exceptions that the positioning messages are terminated at the SRNC and mapped to release 99 RRC messages and that the positioning messages also support broadcast of LCS assistance data in support of the RRC broadcast messages.

The addition of the interface should be compatible the release 99 Iu, Iur and Iub and radio interfaces. The addition of this interface does not preclude the A-GPS to be supported in the SRNC.

**5 Service Aspects**

None identified.

**6 MMI-Aspects**

None identified.

**7 Charging Aspects**

None identified.

**8 Security Aspects**

None identified.

**9 Impacts**

Affects :	USIM	ME	AN	CN	Others
Yes			X		
No	X	X		X	
Don't know					

**10 Expected Output and Time scale (to be updated at each plenary)**

This is a Release 4 Work Item

New specifications						
Spec No.	Title	Prime rsp. WG	2ndary rsp. WG(s)	Presented for information at plenary#	Approved at plenary#	Comments
3GPP TS XX.YYY	SRNC – SMLC Location Protocol	RAN 2	RAN 3	RAN #11	RAN #11	See Note 1.
Affected existing specifications						
Spec No.	CR	Subject		Approved at plenary#		Comments
25.401		UTRAN architecture description; Stage 2		RAN #11		Add new lux interface and new A GPS SMLC network entity.
25.305		UTRAN Stage 2		RAN #11		Modify Network Reference Model to show stand alone SMLC and add stage 2 call flows for A-GPS positioning.

**Note 1 :** From a service invocation perspective this interface would be analogous to the Lb interface as defined in GSM 09.31 and GSM 08.71. From a positioning message perspective new messages need to be defined to align with the release 99 RRC messages. The Lux messages are



terminated at the SRNC and mapped into the existing RRC messages. The new Iux messages are based on both the RRLP messages as defined in GSM 04.31 and the release 99 RRC messages themselves.

To allow for a stand alone SMLC, a new interface is required between the SMLC and the SRNC. The new stage 2 network architecture is shown below:

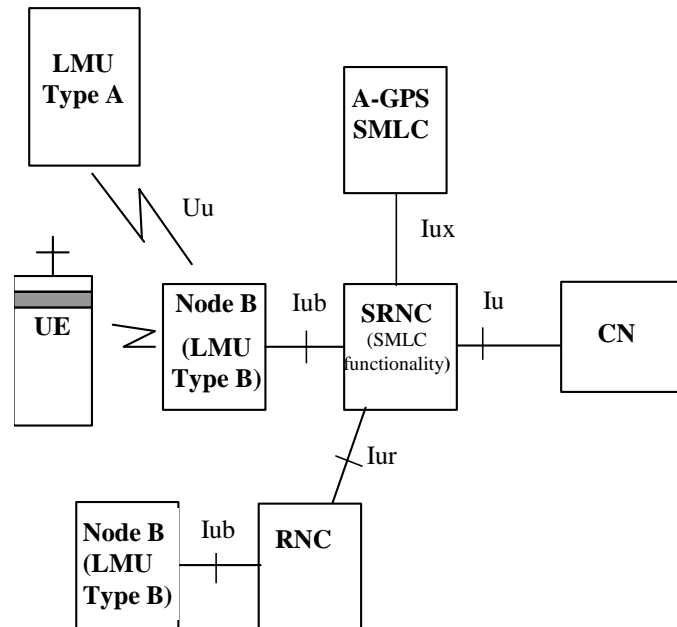

The new interface will need to support two types of messages; service invocation messages and positioning messages. The service invocation messages can be based on the Lb interface as defined in GSM 09.31 and GSM 08.71. The service invocation messages will provide for a request/response message exchange such that the SRNC can query the SMLC for the position of the UE.

The newly defined positioning messages can be based on the positioning messages currently specified in RRC and/or RRLP. In GSM LCS the positioning messages are passed transparently through the BSC over the Um interface. However for this new interface the positioning messages will be terminated at the SRNC and mapped to the corresponding RRC messages. Within the positioning messages there are three sets of messages. The first set of messages is equivalent to the RRLP Measure Position Request / Response message in GSM LCS and the RRC Measurement Control / Report message in UTRAN. The second set of messages is equivalent to the RRLP Assistance Data / Ack message in GSM LCS and the RRC Assistance Data Delivery / Ack message in UTRAN. The third set of messages is equivalent to the RRC LCS related SIB messages in UTRAN.

A sample call flow for a location estimate (either MO or MT) is shown below:

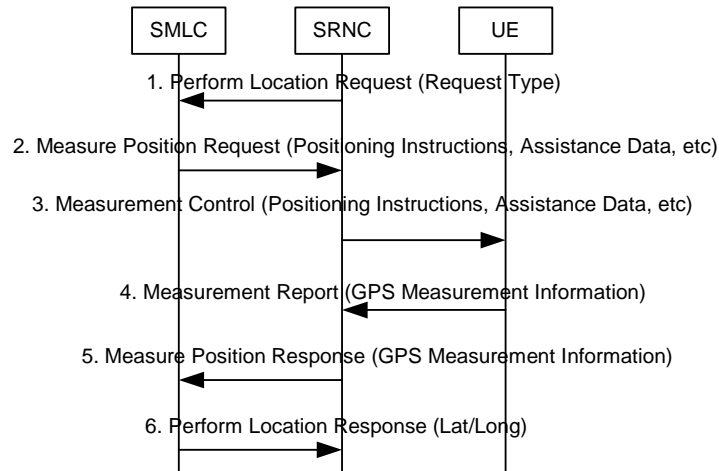

In the case of incomplete assistance data in the “measurement command”, RRC allows for an UP error message to be returned to the SRNC with an explicit request for assistance data that will be provided to the SMLC. This would result in the steps 2 through 5 being repeated.

In the case of an MO request for assistance data, the call flow is basically the same. The only difference would be that the “assistance data” messages would be used.

The application layer messages defined on the interface between the SMLC and the SRNC will use Iups based transport mechanisms.

## 11 Work item reporters

Kirk Burroughs, Qualcomm, San Jose, California, USA

## 12 Work item leadership

RAN 2

## 13 Supporting Companies

LCS Workshop

## 14 Classification of the WI (if known)

	Feature (go to 14a)
X	Building Block (go to 14b)
	Work Task (go to 14c)

14a The WI is a Feature: List of building blocks under this feature

14b The WI is a Building Block: parent Feature UE positioning

xxx1 Provision of SRNC - SMLC Open Interface

14c The WI is a Work Task: parent Building Block

## Annex 2: List of participants

Name	First Name	Company	Phone	Email
Akram	Ammad	Panasonic	+44 1635 58 7766	<a href="mailto:Ammad.akram@mci.co.uk">Ammad.akram@mci.co.uk</a>
Alfert	Burkhard	T-Mobil	+49 251 977 3926	<a href="mailto:Burkhard.alfert@t-mobil.de">Burkhard.alfert@t-mobil.de</a>
Babut	George	Rogers Wireless	+1 416 935 6027	<a href="mailto:Gbabut@rci.rogers.com">Gbabut@rci.rogers.com</a>
Bailey	Ric	Orange	+44 7973 994477	<a href="mailto:Ric.bailey@orange.co.uk">Ric.bailey@orange.co.uk</a>
Bakaimis	Byron	Samsung UK	+44 77 9989 7759	<a href="mailto:Byronbak@aol.com">Byronbak@aol.com</a>
Beckmann	Mark	Siemens AG	+49 5341 906 1814	<a href="mailto:Mark.beckmann@sal.siemens.de">Mark.beckmann@sal.siemens.de</a>
Beeson	Bob	Lucent Tech	+1 623 572 4715	<a href="mailto:Rbeeson@lucent.com">Rbeeson@lucent.com</a>
Bogani	Elena	Omnitel	+39 347 227 0032	<a href="mailto:Elena.bogani@omnitel.it">Elena.bogani@omnitel.it</a>
Brannlund	Tomas	Ericsson	+46 8 585 33576	<a href="mailto:Tomas.brannlund@era.ericsson.se">Tomas.brannlund@era.ericsson.se</a>
Buresta	Alessandro	Cself Telecom Italia Spa	+39 011 228 5548	<a href="mailto:Alessandro.buresta@cself.it">Alessandro.buresta@cself.it</a>
Burroughs	Kirk	Snaptrack / Qualcomm	+1 408 556 0400	<a href="mailto:Kirkb@qualcomm.com">Kirkb@qualcomm.com</a>
Cameron	Ewan	Signalsoft	+44 1292 667 551	<a href="mailto:Ecameron@signalsoft.com">Ecameron@signalsoft.com</a>
Carlsson	Hans	Ericsson	+1 919 472 1471	<a href="mailto:Hans.carlsson@ericsson.com">Hans.carlsson@ericsson.com</a>
Carpenter	Paul	Lucent Technologies	+44 1793 883 818	<a href="mailto:Pcarpenter@lucent.com">Pcarpenter@lucent.com</a>
Clop	Oscar	BT Cellnet	+44 1735 565 568	<a href="mailto:Oscar.clop@btcellnet.net">Oscar.clop@btcellnet.net</a>
Coles	Adrian	BT Cellnet	+44 1753 280 445	<a href="mailto:Adrian.coles@btcellnet.net">Adrian.coles@btcellnet.net</a>
Corre	Laurence	Alcatel	+33 1 30 77 33 72	<a href="mailto:Laurence.corre@alcatel.fr">Laurence.corre@alcatel.fr</a>
Courau	Francois	Alcatel SA	+33 60 882 2022	<a href="mailto:Francois.courau@alcatel.fr">Francois.courau@alcatel.fr</a>
Crisp	Graham	Marconi	+44 115 906 4635	<a href="mailto:Graham.crisp@marconi.com">Graham.crisp@marconi.com</a>
Daryanani	Hiro	INVISIX / Motorola	+44 208 622 3530	<a href="mailto:Hiro.daryanani@invisix.com">Hiro.daryanani@invisix.com</a>
Davidian	J.J.	DoCoMo Europe	+33 1 56 88 30 30	<a href="mailto:Davidian@docomo.fr">Davidian@docomo.fr</a>
Davies	Rob	One2One	+44 7958 312 757	<a href="mailto:Robert.davies@one2one.co.uk">Robert.davies@one2one.co.uk</a>
Deluca	Enrico	Ericsson	+39 081 51 47 629	<a href="mailto:Enrico.deluca@ericsson.com">Enrico.deluca@ericsson.com</a>
Deshmukh	Sanjay	Motorola Inc.	+1 847 632 6935	<a href="mailto:Sanjay.deshmukh@motorola.com">Sanjay.deshmukh@motorola.com</a>
Devaney	David	Lucent Technologies	+1 409 862 2875	<a href="mailto:Dbdevaney@msn.com">Dbdevaney@msn.com</a>
Edge	Stephen	Siemens	+1 561 923 6574	<a href="mailto:Stepehn.edge@icn.siemens.com">Stepehn.edge@icn.siemens.com</a>
Fauconnier	Denis	Nortel Networks	+33 1 39 44 52 87	<a href="mailto:Dfauconn@nortelnetworks.com">Dfauconn@nortelnetworks.com</a>
Fernandes	Luis	BT Cellnet	+44 1753 565 397	<a href="mailto:Luis.fernandes@btcell.net">Luis.fernandes@btcell.net</a>
Gireau	Simon	Bouygues Telecom	+33 1 55 63 45 37	<a href="mailto:Sgireau@bouyguestelecom.gr">Sgireau@bouyguestelecom.gr</a>
Grilli	Francesco	Qualcomm	+1 858 845 3742	<a href="mailto:Fgrilli@qualcomm.com">Fgrilli@qualcomm.com</a>
Gu	Y. Jay	Mobisphere / Siemens	+44 118 986 5738	<a href="mailto:Jay.gu@mobishere.com">Jay.gu@mobishere.com</a>
Ishii	Kenichi	NEC	+81 44 856 2255	<a href="mailto:Ishii@bc.jp.nec.com">Ishii@bc.jp.nec.com</a>
Kall	Jan	Nokia	+358 40 040 0056	<a href="mailto:Jan.kall@nokia.com">Jan.kall@nokia.com</a>
Kangas	Ari	Ericsson	+46 8 404 4299	<a href="mailto:Ari.kangas@era.ericsson.se">Ari.kangas@era.ericsson.se</a>
Kastein	John	Motorola	+1 847 632 6911	<a href="mailto:John.kastein@motorola.com">John.kastein@motorola.com</a>
Kisler	Drit	Comverse Network System	+972 54 453 400	<a href="mailto:Drit_kisler@comverse.com">Drit_kisler@comverse.com</a>
Kunczier	Harald	Ftw	+43 1 505 2830 24	<a href="mailto:Kunczier@ftw.at">Kunczier@ftw.at</a>
Lautier	Laurence	Nortel Networks	+33 1 39 44 32 26	<a href="mailto:Laurierl@nortelnetworks.com">Laurierl@nortelnetworks.com</a>
Lazaro	Carlos	Telefonica Moviles Espana	+34 630 00 32 01	<a href="mailto:Lazaro_c@tsm.es">Lazaro_c@tsm.es</a>
Livingston	Margaret	Nokia	+1 972 894 9740	<a href="mailto:Margaret.livingston@nokia.com">Margaret.livingston@nokia.com</a>
Lombardo	Rosa	Omnitel	+39 348 999 9919	<a href="mailto:Rosa.lombardo@omnitel.it">Rosa.lombardo@omnitel.it</a>
Looyestijn	John	Libertel-Vodafone	+31 43 355 7068	<a href="mailto:John.looyestijn@libertel.nl">John.looyestijn@libertel.nl</a>
Lu	Sze-Ching	ICO Global Comms	+44 208 600 1064	<a href="mailto:Sze-ching.lu@ico.com">Sze-ching.lu@ico.com</a>
Ludden	Brendan	Vodafone	+44 1635 684 765	<a href="mailto:Brendan.ludden@vf.vodafone.co.uk">Brendan.ludden@vf.vodafone.co.uk</a>
Maanoja	Markus	Nokia	+358 40 538 5804	<a href="mailto:Markus.maanoja@nokia.com">Markus.maanoja@nokia.com</a>

Madads	Hashem	Hutchinson 3G	+44 20 7499 1886	<a href="mailto:Hmadadi@attglobal.net">Hmadadi@attglobal.net</a>
Martin	Ron	Lucent	+1 630 979 8818	<a href="mailto:Ronaldmartin@lucent.com">Ronaldmartin@lucent.com</a>
Mattlener	Stefan	T-Mobil	+49 228 936 4832	<a href="mailto:Stefan.mattlener@t-mobil.de">Stefan.mattlener@t-mobil.de</a>
Maueille	Caroline	France Telecom	+33 1 45 29 57 71	<a href="mailto:Caroline.maueille@francetelecom.com">Caroline.maueille@francetelecom.com</a>
Mecrow	Steve	BT	+44 1394 380 694	<a href="mailto:Steve.mecrow@bk.com">Steve.mecrow@bk.com</a>
Mirabile	Fabio	Maroni Mobile	+33 010 600 3728	<a href="mailto:Fabio.mirabile@marconi.com">Fabio.mirabile@marconi.com</a>
Morris	Paul	Cambridge Positioning	+44 1223 326 945	<a href="mailto:Paul.morris@cursor-systems.com">Paul.morris@cursor-systems.com</a>
Movtier	Philippe	Alcatel	+33 609 28 16 73	<a href="mailto:Philippe.movtier@alcatel.fr">Philippe.movtier@alcatel.fr</a>
Mueller	Justin	Voicestream	+1 425 444 1483	<a href="mailto:Justin.mueller@voicestream.com">Justin.mueller@voicestream.com</a>
Müller	Wilhelm	Siemens AG	+49 89 722 31626	<a href="mailto:Wilhelm.mueller@icn.siemens.de">Wilhelm.mueller@icn.siemens.de</a>
Paint	Frederic	Telenor AS	+47 63 84 88 76	<a href="mailto:Frederic.paint@telenor.nu">Frederic.paint@telenor.nu</a>
Primo	Avi	Celltick	+972 54 386 747	<a href="mailto:Aprimo@celltick.com">Aprimo@celltick.com</a>
Probasco	Scott	Nokia	+1 817 307 4579	<a href="mailto:Scott.probasco@nokia.com">Scott.probasco@nokia.com</a>
Pudney	Chris	Vodafone	+44 1635 673 397	<a href="mailto:Chris.pudney@vf.vodafone.co.uk">Chris.pudney@vf.vodafone.co.uk</a>
Sahnoun	Rym	France Telecom	+1 33 55 22 1887	<a href="mailto:Rym.sahnoun@francetelecom.com">Rym.sahnoun@francetelecom.com</a>
Sarlet-Harper		Microsoft	+33 614 54 1226	<a href="mailto:lsarh@microsoft.com">lsarh@microsoft.com</a>
Schmidt	Kurt	SiRF Technology	+1 310 643 1322	<a href="mailto:Kurt@sirf.com">Kurt@sirf.com</a>
Sharar	Tzvika	Comverse Network System	+972 3 766 3424	<a href="mailto:Tzaika.shahar@comverse.com">Tzaika.shahar@comverse.com</a>
Sheynblat	Len	Snaptrack / Qualcomm	+1 408 556 0400	<a href="mailto:Lens@qualcomm.com">Lens@qualcomm.com</a>
Stanbridge	Iain	Orange	+44 1454 206 377	<a href="mailto:Iain.stanbridge@orange.co.uk">Iain.stanbridge@orange.co.uk</a>
Stonor	Robert	Mobisphere	+44 118 986 5725	<a href="mailto:Robert.stonor@mobisphere.com">Robert.stonor@mobisphere.com</a>
Sugiyama	Katsumasa	Fujitsu, Japan	+81 44 740 8159	<a href="mailto:Ksuguyama@jp.fujitsu.com">Ksuguyama@jp.fujitsu.com</a>
Sundberg	Erik	Telia Mobile	+46 8 601 7396	<a href="mailto:Erik.g.sundberg@telia.se">Erik.g.sundberg@telia.se</a>
Sundresh	Bok	Motorola Ltd.	+44 1256 790 790	<a href="mailto:B.sundresh@motorola.com">B.sundresh@motorola.com</a>
Toepfer	Armin	Mannesmann Mobilfunk	+49 211 533 2838	<a href="mailto:armin.toepfer@d2vodafone.de">armin.toepfer@d2vodafone.de</a>
Vänttinen	Veijo	Nokia	+358 40 703 8140	<a href="mailto:Veijo.vanttinen@nokia.com">Veijo.vanttinen@nokia.com</a>
Vayanos	Hector	Qualcomm	+1 858 845 3011	<a href="mailto:Avayanos@qualcomm.com">Avayanos@qualcomm.com</a>
Williams	David	Qualcomm Europe	+33 492 38 82 33	<a href="mailto:Dwilliams@qualcomm.com">Dwilliams@qualcomm.com</a>
Wilson	Jon	Snaptrack / Qualcomm	+1 408 556 1137	<a href="mailto:Jr.wilson@qualcomm.com">Jr.wilson@qualcomm.com</a>
Zarri	Michele	One2One Personal Comms. Ltd.	+44 79 3200 2114	<a href="mailto:Michele.zarri@one2one.co.uk">Michele.zarri@one2one.co.uk</a>
Zhao	Yilin	Motorola	+1 847 523 3291	<a href="mailto:Yilin.zhao@motorola.com">Yilin.zhao@motorola.com</a>

### Annex 3: List of documents

TD No.	TITLE	SOURCE	Agenda Item	Replaced by
001	Agenda	Chairman	2	
002	Requirements for open interfaces in LCS	Orange	6	
003	GSM LCS Overview Assisted GPS Perspective	Qualcomm	3b	
004	Wireless Assisted GPS: Personal Location for GSM and GSM Evolution	Qualcomm	3c	
005	Proposed RAN Work Item for Open Interface	Qualcomm	7b	22
006	SA1 White Paper on LCS Changes	Qualcomm	5a	
007	SA2 White Paper on Open Interface within UTRAN	Qualcomm	5a	
008	SA LCS Work Item	MCC	7a	
009	LS from GSM NA: Location Services Functionality in 3GPP Specifications	MCC	5b	
010	Draft Change Request against TS 25.305 to support Open Interface	Qualcomm	6b	
011	withdrawn			
012	Not allocated			
013	Not allocated			
014	GERAN LCS Standardization : LCS Workshop January 11-12, 2001	Chairperson GERAN LCS Workshop	4b	
015	Location Service Requirements	3GPP SA1 Vice-chair	3a/4a	
016	LCS Architecture	Ericsson	5a	
017	Current LCS architecture in UMTS and standalone SMLC	Nokia	4b	
018	OTDOA-PE UP Method: LCS overview discussion and formulation of overall LCS work programme	Panasonic	4c	
019	Overview of 2G LCS Technologies and Standards	Motorola	3a	
020	Support for LCS in GERAN release 4 in lu mode	Nortel	6	
021	RAN2 status on LCS	Chairman 3GPP RAN2	4b	
022	Work Item Description for an Open SMLC-SRNC Interface within the UTRAN to support A-GPS Positioning	Qualcomm	7	
023	Work Item Description for an Open SMLC-SRNC Interface within the UTRAN to support A-GPS Positioning	LCS Workshop	7	