

3GPP TS 23.221 V2.0.0 (2001-03)

Technical Specification

**3rd Generation Partnership Project;
Technical Specification Group Services and System Aspects;
Architectural requirements;**

(Release 4)



The present document has been developed within the 3rd Generation Partnership Project (3GPP™) and may be further elaborated for the purposes of 3GPP.

The present document has not been subject to any approval process by the 3GPP Organizational Partners and shall not be implemented. This Specification is provided for future development work within 3GPP only. The Organizational Partners accept no liability for any use of this Specification. Specifications and reports for implementation of the 3GPP™ system should be obtained via the 3GPP Organizational Partners' Publications Offices.

Keywords

<keyword[, keyword]>

3GPP

Postal address

3GPP support office address

650 Route des Lucioles – Sophia Antipolis
Valbonne – FRANCE
Tel. : +33 4 92 94 42 00 Fax : +33 4 93 65 47 16

Internet

<http://www.3gpp.org>

Copyright Notification

No part may be reproduced except as authorized by written permission.
The copyright and the foregoing restriction extend to reproduction in all media.

© 2000, 3GPP Organizational Partners (ARIB, CWTS, ETSI, T1, TTA, TTC).
All rights reserved.

Contents

Foreword.....	5
Introduction.....	5
1 Scope	6
2 References	6
3 Definitions, symbols and abbreviations.....	7
3.1 Definitions.....	7
3.2 Symbols.....	7
3.3 Abbreviations	7
4 UMTS/GSM domains and subsystems.....	8
4.1 Allowed network and terminal configurations	8
4.2 Circuit switched (CS) core network domain	9
4.2.1 Iu mode to Iu mode handover for circuit switched services	9
4.2.2 A mode to Iu mode handover for CS services	9
4.2.3 General principles for use of CS-MGW resources	9
4.2.4 Transcoder location	10
4.3 Packet Switched (PS) core network domain	10
4.4 Void.....	10
4.5 Cross Core Network Domain Requirements	10
4.6 UTRAN.....	10
4.7 GERAN.....	10
5 IP addressing	10
5.1 IP version issues.....	10
5.2 Interoperability between IPv4 and IPv6 networks	10
5.2.1 IPv4/IPv6 Mobile connecting to IPv4 and IPv6 networks.....	11
5.2.2 IPv6 only Mobile connecting to IPv4 network.....	11
5.2.3 IPv6 Mobile connected to an IPv6 Device via an IPv4 network	12
6 Mobility management.....	12
6.1 Introduction.....	12
6.2 Location management and mobility management concept overview.....	12
6.2.1 Non-combined procedures.....	12
6.2.2 Use of combined procedures	15
6.3 Description of the location management and mobility management concept - area concepts	15
6.3.1 Introduction	15
6.3.2 Location areas.....	15
6.3.3 Routing areas	16
6.3.4 RAN internal areas	16
6.3.5 Relationship between the different areas	16
6.3.6 Hierarchical tracking concept.....	17
6.4 Relationship between MM and SM states for an UE	17
6.5 Requirement in case of temporarily loss of coverage of packet UE.....	17
6.6 MM functionality in different UE service states	17
6.7 The RRC state machine.....	18
6.8 Relationship between CS and PS service states and RRC state for an UE.....	19
6.9 Service registration and location update.....	20
6.9.1 Introduction	20
6.9.2 Location area update.....	21
6.9.3 Routing area update.....	21
6.9.4 Combined updates	21
6.10 Paging initiated by CN	21
6.11 Signalling connection establishment	21
6.12 Relations between SRNS relocation and location registration.....	22
6.13 Requirements on identifiers for UMTS and GSM	23
6.14 Use of MM system information	24

6.15	Signalling procedures.....	24
6.15.1	Idle mode procedures.....	24
6.15.1.1	Location Area update.....	24
6.15.1.2	Routing Area Update.....	26
6.15.1.3	Periodic registration towards both CN nodes without use of Gs.....	26
6.15.1.4	Periodic registration with use of Gs or combined MSC+SGSN node.....	26
6.15.1.5	UE initiated combined detach procedure when using Gs or combined MSC+SGSN node.....	26
6.15.2	SRNS Relocation.....	26
6.16	RAN coordination.....	26
7	Call control.....	27
7.1	General Aspects.....	27
Annex A (informative): Change history		27

Foreword

This Technical Specification has been produced by the 3rd Generation Partnership Project (3GPP).

The contents of the present document are subject to continuing work within the TSG and may change following formal TSG approval. Should the TSG modify the contents of the present document, it will be re-released by the TSG with an identifying change of release date and an increase in version number as follows:

Version x.y.z

where:

x the first digit:

- 1) presented to TSG for information;
- 1) presented to TSG for approval;
- 1) or greater indicates TSG approved document under change control.

Y the second digit is incremented for all changes of substance, i.e. technical enhancements, corrections, updates, etc.

z the third digit is incremented when editorial only changes have been incorporated in the document.

Introduction

This clause is optional. If it exists, it is always the third unnumbered clause.

1) Scope

This document covers details the architectural requirements for the GSM in Iu mode and UMTS systems. In particular it details the high level requirements for the Circuit Switched (CS) Domain and the stage 2 procedures that span more than one domain/subsystem within UMTS and GSM. The reference model to which these procedures apply can be found within 3G TS 23.002 [1]. In addition, A mode to Iu mode handover for CS services is addressed. Detailed architectural requirements within the subsystems are contained within the remainder of the 23 series of specifications e.g. the requirements for the Packet Switched (PS) domain are contained within 3G TS 23.060 [2] and the requirements for the Bearer Independent CS Core Network are contained in 3G TS 23.205[14].

1) References

The following documents contain provisions which, through reference in this text, constitute provisions of the present document.

- References are either specific (identified by date of publication, edition number, version number, etc.) or non-specific.
- For a specific reference, subsequent revisions do not apply.
- For a non-specific reference, the latest version applies.

This specification may contain references to pre-Release-4 GSM specifications. These references shall be taken to refer to the Release 4 version where that version exists. Conversion from the pre-Release-4 number to the Release 4 (onwards) number is given in subclause 6.1 of 3GPP TR 41.001.

- [1] 3GPP TS 23.002: "Network Architecture".
- [2] 3GPP TS 23.060: "General Packet Radio Service (GPRS) Service description; Stage 2".
- [3] 3GPP TS 23.012: "Location management procedures"
- [5] 3GPP TS 25.331: "Radio Resource Control (RRC) Protocol Specification"
- [6] 3G TS 25.301: "Radio interface protocol architecture"
- [7] 3G TS 25.303: "UE functions and inter-layer procedures in connected mode"
- [8] 3GPP TR 21.905: "3G Vocabulary".
- [9] 3GPP TS 25.413: "UTRAN Iu interface RANAP signalling"
- [10] 3GPP TS 25.410: "UTRAN Iu Interface: General Aspects and Principles"
- [11] void
- [12] 3G TS 43.051 "GERAN Overall Description"
- [13] 3G TS 23.153, "Out of Band Transcoder Control – Stage 2".
- [14] 3G TS 23.205, "Bearer Independent CS Core Network – Stage 2"
- [15] 3G TR 25.931: "UTRAN Functions, examples on signalling procedures"
- [16] RFC2766 "Network Address Translation – Protocol Translation (NAT-PT)", G. Tsirtsis, P. Srisuresh. February 2000.
- [17] RFC2893 "Transition Mechanisms for Ipv6 Hosts and Routers", R. Gilligan, E. Nordmark, August 2000.
- [18] 3G TS 25.401 "UTRAN Overall Description"

1) Definitions, symbols and abbreviations

1)-1. Definitions

For the purposes of the present document, the terms defined in 3GPP TR 21.905 [8] apply:

example: text used to clarify abstract rules by applying them literally.

In Iu mode :

In A/Gb mode:

Editor's Note: The two terms above should be referenced to the definitions defined by CN1. Need to determine if these will be placed in 23.905

RAN: within this document, the term RAN (Radio Access Network) is used to refer to both the UTRAN and GERAN in Iu mode. RAN specific abbreviations such as URA when used with the term RAN, apply to both UTRAN and GERAN in Iu mode, unless otherwise stated.

1). Symbols

For the purposes of the present document, the following symbols apply:

1). Abbreviations

For the purposes of the present document, the following abbreviations apply:

ATM	Aysnchronous Transfer Mode
CM	Connection Management
CN	Core Network
CS	Circuit Switched
CSCF	Call/Session Control Function
CS-MGW	Circuit Switched Media Gateway
DHCP	Dynamic Host Configuration Protocol
GERAN	GSM/EDGE Radio Access Network
GGSN	Gateway GPRS Support Node
GPRS	General Packet Radio Service
GTP	GPRS Tunnelling Protocol
HLR	Home Location Register
IMSI	International Mobile Station Identifier
IMT2000	
IP	Internet Protocol
IPSec	IP Security protocol
LA	Location Area
LAC	Location Area Code
LAN	Local Area Network
LLC	Logical Link Control
LM	Location Management
MAP	Mobile Application Part
MGCF	Media Gateway Control Function
MGW	Media Gateway

MM	Mobility Management
MRF	Media Resource Function
MSC	Mobile Switching Centre
NAT	Network Address Translator
NGN	Next Generation Networks
OoBTC	Out of Band Transcoder Control
PDA	Personal Digital Assistant
PDP	Packet Data Protocol
PLMN	Public Land Mobile Network
PS	Packet Switched
RA	Routing Area
RAC	Routing Area Code
RAI	Routing Area Identifier
RAN	Radio Access Network
RANAP	Radio Access Network Application Part
RLC	Radio Link Control
RNC	Radio Network Controller
RNTI	Radio Network Temporary Identifier
RRC	Radio Resource Control
SGSN	Serving GPRS Support Node
SIP	Session Initiation Protocol
SRNS	Serving Radio Network Subsystem
SS7	Signalling System No. 7
STM	Synchronous Transfer Mode
SGW	Signalling gateway
SRNS	Serving Radio Network Subsystem
TCP	Transmission Control Protocol
TMSI	Temporary Mobile Station Identifier
TrFO	Transcoder Free Operation
UDP	User Datagram Protocol
UE	User Equipment
UMTS	Universal Mobile Telecommunications System
URA	UTRAN Registration Area
UTRAN	UMTS Terrestrial Radio Access Network
VHE	Virtual Home Environment
VLR	Visited Location Register

4 UMTS/GSM domains and subsystems

1)-1. ⊕ Allowed network and terminal configurations

A 3GPP network is divided into a radio AN and a CN, which are connected via an open interface over the Iu reference point. Furthermore, the core network is from a functional point of view divided into a PS Domain and a CS Domain (see 3G TS 23.002 [1]).

The following network configurations shall be allowed:

- 1) networks which provide the functionality of CS Domain and PS Domain;
- 1) networks which only provide the functionality of the CS Domain;
- 1) networks which only provide the functionality of the PS Domain.

The following terminal configurations shall be allowed:

- 1) terminals which are able to access both to the CS Domain and PS Domain;
- 1) terminals which are only able to access to the PS Domain;

- 1) terminals which are only able to access to the CS Domain.

It shall be noted that a terminal which is only able to access to e.g. the PS Domain supports only mobility management, protocols etc. of the that domain. The different configurations given above shall not prevent CS-type services from being delivered over the PS domain.

1)-1. □ **Circuit switched (CS) core network domain**

1).. **Iu mode to Iu mode handover for circuit switched services**

For Iu mode to Iu mode Inter-MSC Hand-Over / SRNS relocation the MAP E interface transporting RANAP messages shall be used. Alternatively, in the case of intra-PLMN handover, the GSM to UMTS inter-system handover or SRNS relocation between two MSC-areas may be executed as intra-MSC inter-system handover or SRNS relocation respectively. In such a case this will be performed by utilising a direct SCCP connection between the target RNC located in the target MSC-area and the MSC server already involved in the call.

For handover of circuit-switched services involving the change of CN equipment (only CS-MGW or CS-MGW and MSC-server) the anchor principle shall be applied.

- The first MSC Server involved in a call will become the Anchor MSC Server for this call during and after handover, and will remain in the call until the call is released. Every subsequent handover (Intra and Inter) will be controlled by this MSC Server.
- The first CS-MGW involved in a call will become the Anchor CS-MGW for this call during and after handover, and will remain in the call until the call is released. The Nc interface is anchored in the CS-MGW, the correlation between CS-MGW to PSTN and the CS-MGW to RAN remain fixed until the call is released.

1).. □ **A mode to Iu mode handover for CS services**

For A mode to Iu mode inter-system Inter-MSC Hand-Over (GSM to UMTS) the MAP E interface transporting BSSMAP messages shall be used. As a network option, in the case of intra-PLMN inter-system handover from A mode to Iu mode, the handover between two MSC-areas may be executed as

- intra-MSC handover, if the serving BSS is connected to the Anchor MSC; or
- subsequent intra-MSC handover or subsequent inter-MSC handover back to the Anchor MSC Server, if the serving BSS is connected to an MSC-B. The decision between these two alternatives is implementation and network configuration dependent.

The procedure will be performed by utilising a direct SCCP connection between the target RNC located in the target MSC-area and the Anchor MSC or MSC-B, respectively.

1).. □ **General principles for use of CS-MGW resources**

The following principles for use of CS-MGW resources apply:

1. it shall not be necessary to have the CS-MGW co-located with the MSC Server;
2. the CS-MGW resources need not be associated with any particular MSC Server (see note 1);
3. it shall be possible for any MSC Server to request resources of any CS-MGW in the network (see note 1);
4. it shall be possible for an RNC to connect to the CS-MGW indicated by the MSC server;

Note 1: For points 2 and 3 above, issues related to O&M procedures such as where notification of restart of a CS-MGW should be sent to, need to be considered. Extensions to H.248 may be required.

The specification of the Bearer Independent CS CN which uses the CS-MGW is in TS 23.205 [14].

1)- 1.. □ Transcoder location

The transcoders are located in the core network. They may be located in the CS-MGW at the border to the RAN (i.e the CS-MGW at the Iu interface) or at the CS-MGW at the edge of the core network (e.g. at the edge towards the PSTN/ISDN) [13].

1). □ Packet Switched (PS) core network domain

The requirements for the PS domain are in 23.060[2].

1). □ Void

1). □ Cross Core Network Domain Requirements

The specifications shall support the option of IP transport for the MAP and CAP based interfaces

1). □ UTRAN

The requirements for the UTRAN are in the 25-series. An overview can be found in 3G TS 25.401 [18].

1). □ GERAN

The requirements for the GERAN are in 3G TS 43.051 [12]

1) IP addressing

1)-1. □ IP version issues

The UMTS/GSM architecture shall support Ipv4 / Ipv6 based on the statements below.

- 1) IP transport between network elements of the IP Connectivity services (between RNC, SGSN and GGSN) and IP transport for the CS Domain: both Ipv4 / Ipv6 are options for IP Connectivity
- 1) Access to existing data services (Intranet, Internet,...):
- 1) The UE can access Ipv4 and Ipv6 based services.

1)-1. □ Interoperability between Ipv4 and Ipv6 networks

Editor's Note: This text needs to be reworded to remove reference to the IM CN Subsystem

As described in TS 23.228 [11] the IM CN Subsystem is based only on Ipv6. Thus, it is needed to describe how these mobiles can connect to legacy Ipv4 services. This section describes three different interworking scenarios: UE is Ipv4 and Ipv6 capable, Ipv6 only UE, and Ipv6 UE connected via Ipv4 network to an Ipv6 device. These scenarios are examples of Ipv6 and Ipv4 interworking. The scenarios presented below only considered cases of a Transition Gateway (TrGW) for generic services and specialist services may require additional functionality at the application level.

1)- 1.. □ Ipv4/Ipv6 Mobile connecting to Ipv4 and Ipv6 networks

An installation where the UE has both Ipv4 and Ipv6 stacks is shown in Figure 5-1. As depicted, the terminal connects to the Ipv4 device directly using an Ipv4 PDP Context. Hence, the UE appears to be a standard Ipv4 node to the external Ipv4 network. This scenario does not need any specific transition support from the network. However, it requires both versions of IP at the UE. The GGSN in this scenario may be different for the Ipv6 and the Ipv4 connections.

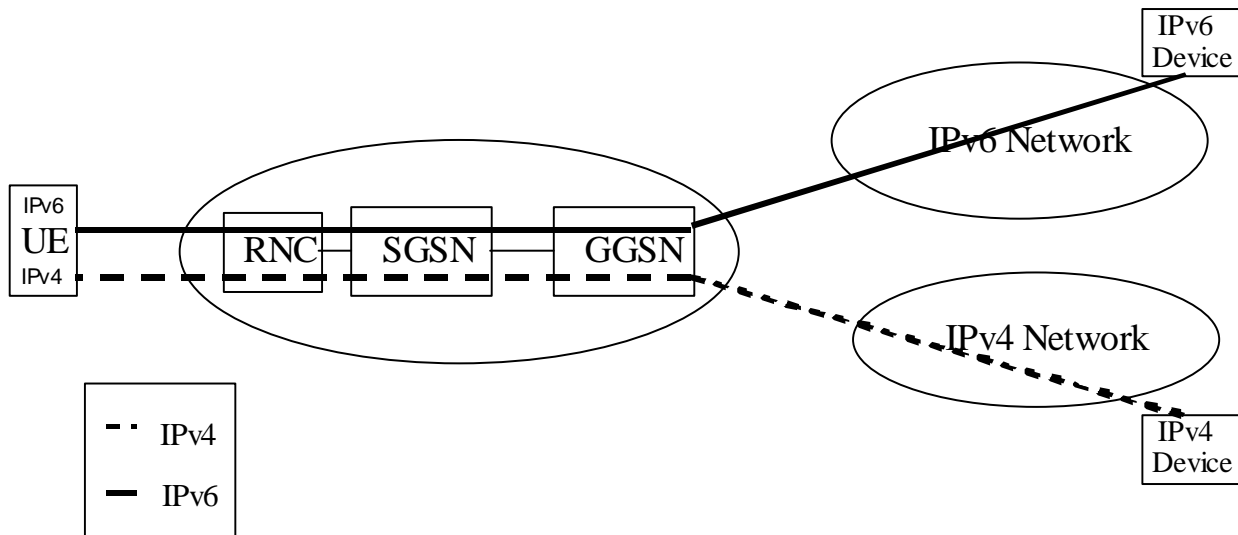

Figure 5-1 UE with Ipv4 and Ipv6 capability connecting to Ipv4 and Ipv6 networks

1)-1.-1. □ Ipv6 only Mobile connecting to Ipv4 network

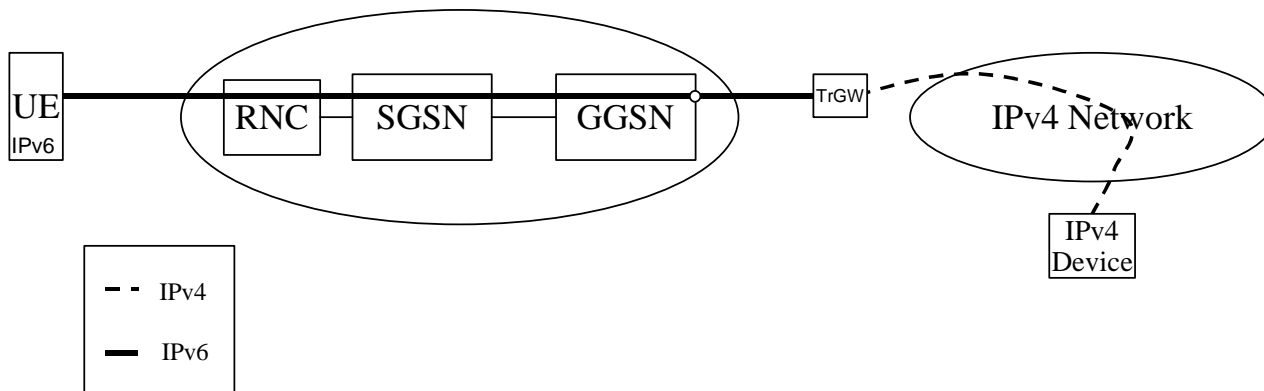

Figure 5-2 Ipv6 only mobile connecting to Ipv4 data services

Figure 5-2 shows an Ipv6 only terminal connected to an Ipv4 device. The UE is using an Ipv6 PDP Context for access to a Transition Gateway (TrGW) that translates the Ipv6 packets to Ipv4 and vice versa. The TrGW may be implemented as a Network Address Translation – Protocol Translation (NAT-PT) [16] to convert Ipv6 traffic coming from the UE to Ipv4 traffic and vice versa.

NAT-PT is a combination of NAT-like address translation and IP header conversion as described in [16]. NAT-PT uses a pool of Ipv4 addresses for assignment to Ipv6 nodes on a dynamic basis as sessions are initiated across v4-v6 boundaries. NAT-PT binds addresses in the v6 network with addresses in the v4 network to provide transparent routing of packets traversing address realms. This requires no changes to end nodes and IP packet routing is completely transparent to them. It does, however, require NAT-PT to track the sessions it supports and mandates that inbound and outbound packets pertaining to a session traverse the same NAT-PT device.

1)- 1.. 隗 Ipv6 Mobile connected to an Ipv6 Device via an Ipv4 network

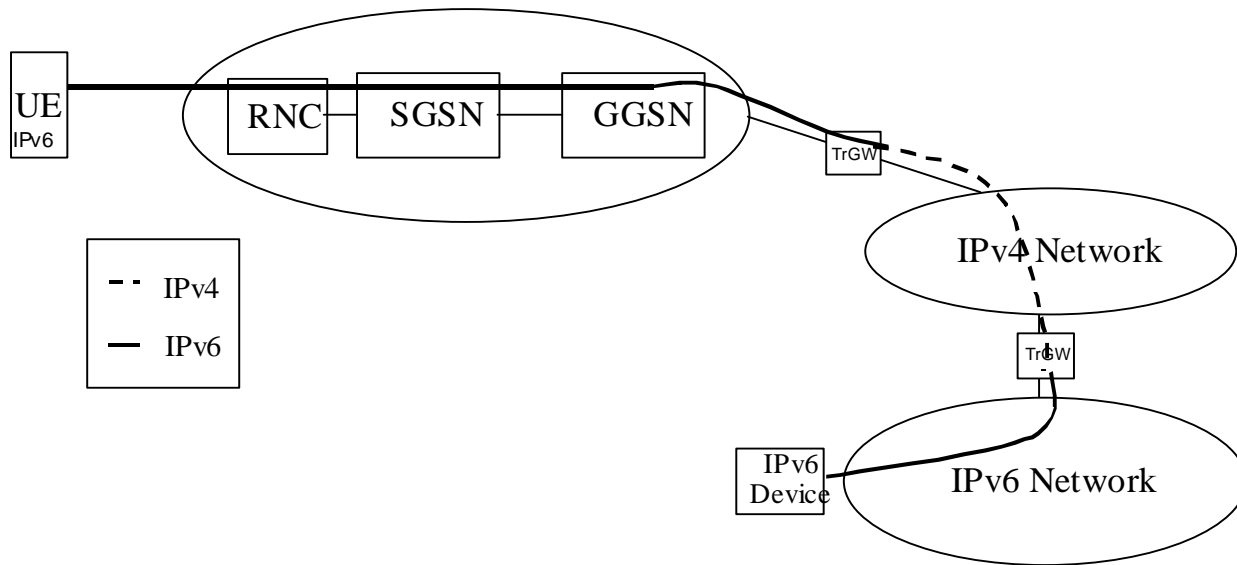

Figure 5-3 Ipv6 mobile connected to an Ipv6 device via an Ipv4 network

Figure 5-3 shows a case where an Ipv4 network lies between two Ipv6 domains. The Ipv6 domains can be interconnected using IETF standard mechanisms such as automatic or configured signalling of Ipv6 over Ipv4 [17].

1) Mobility management

1)-1. Introduction

From a logical point of view, the CN encompasses two domains, a CS domain and a PS domain. The RAN can be connected either to both these CN domains or to one of the CN domains.

A single RRC connection (between RAN and UE) shall carry all user plane and signalling flows to/from a UE. This is regardless of where in the CN they originate/terminate.

The 3GPP specifications for UMTS and GSM in Iu mode shall support compatibility with GSM network in A/Gb mode from the point of view of roaming and handover. For the LM/MM functionality point of view this implies among other things the following:

- 1) IMSI shall be used as the common user identity in the two CN domains;
- 1) common MAP signalling is applied to networks supporting either Iu or A/Gb mode or both.
- 1) radio network parameters and radio resource management should be isolated in the RAN.

The LM/MM techniques used should minimise radio resource usage of the RAN.

1)-1. 隗 Location management and mobility management concept overview

1).. Non-combined procedures

From a logical point of view, the CN consists of two domains, a CS domain and a PS domain or one of these domains.

Each domain has its own service state machine. An UE, that is supporting both CS services and PS services, has a CS service state machine and a PS service state machine. The two peers of the service state machine are working independently to each other, although associated to the same UE. The UE-CN signalling aims to keep the peer entities synchronised.

As an introduction, figure 6.1 and figure 6.2 give an overview of the UE registration and connection principles when the CN consists of two separate PS and CS service nodes or one combined CS and PS service node.

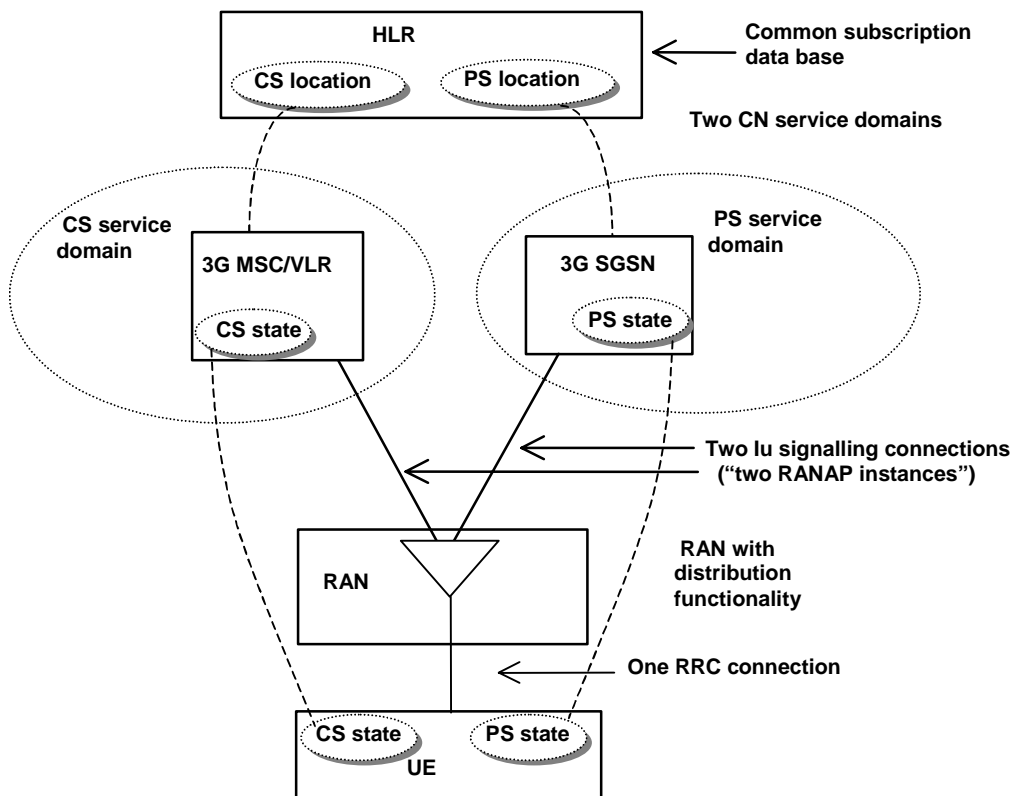

Figure 6.1: Overview of the UE registration and connection principles for the separate CN architecture case

In the separate CN architecture case, the CN consists of both a CS domain with evolved MSC/VLR, 3G_MSC/VLR, as the main serving node and an PS domain with evolved SGSN/GGSN, 3G_SGSN and 3G GGSN, as the main serving nodes.

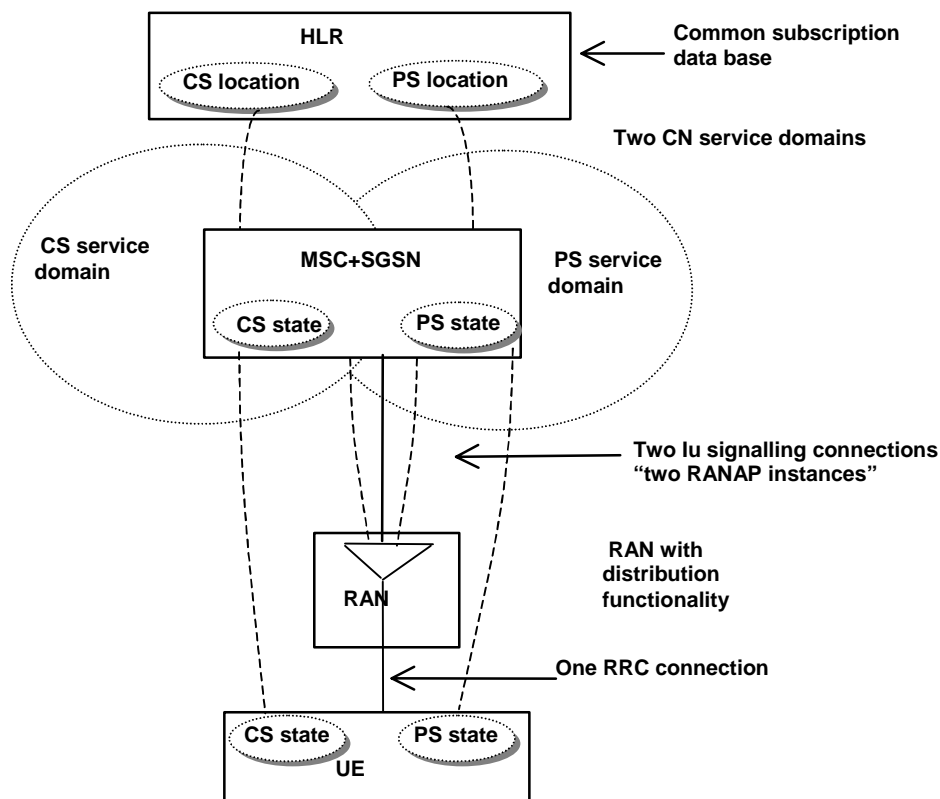

Figure 6.2: Overview of the UE registration and connection principles for the integrated CN architecture case

In the integrated CN architecture case, the CN consists of both a CS domain and an PS domain with an combined MSC and SGSN as the main serving node.

The main PS service states are PS-DETACHED, PS-IDLE and PS-CONNECTED. The main CS service states are CS-DETACHED, CS-IDLE and CS-CONNECTED. For the respective domain there are specific related MM system information controlling the MM functionality of the UE.

The aim of the RAN is to offer one unified set of radio bearers which can be used for bursty packet traffic and for traditional telephony traffic. Therefore, only one logical control channel structure is used for all kind of traffic. The radio resource handling is RAN internal functionality and the CN does not define the type of radio resource allocated.

The Radio Resource Control (RRC) has two modes, RRC Connected mode and RRC Idle mode. The RRC mode describes which identity is used to identify the UE. In RRC Idle mode the UE is identified by a CN associated identity. In RRC Connected mode the UE is assigned a Radio Network Temporary Identity to be used as UE identity on common transport channels. When the UE is allocated dedicated transport channels, it uses the inherent addressing provided by these transport channels.

In PS-CONNECTED state the UE is in RRC Connected mode. In CS-CONNECTED state the UE is in RRC Connected mode.

For the mobility functionality, four different area concepts are used. Location Areas (Las) and Routing Areas (Ras) are used in the CN. UTRAN Registration Areas and Cell Areas are used in the RAN. Las are related to CS services. Ras are related to PS services.

One LA is handled by one CN node. For an UE that is registered in a LA, this implies that the UE is registered in the specific CN node handling this specific LA. One RA is handled by one CN node. For an UE that is registered in a RA, this implies that the UE is registered in the specific CN node handling this specific RA. LA is used by the 3G_MSC/VLR for paging the UE. RA is used by the 3G_SGSN for paging the UE. UTRAN Registration Areas and Cell Areas are only visible in the RAN and used in RRC-Connected mode.

For the relations between LA and RA is described in subclause 4.3.2.

In RRC Idle mode it is the broadcast MM system information (e.g. information about the present LA and present RA) that determines when the UE initiates a location registration procedure towards the CN. An UE crossing an LA border,

in state CS-IDLE and RRC Idle mode, shall initiate LA update towards the CN. An UE crossing an RA border, in state PS-IDLE and RRC Idle mode, shall initiate RA update towards the CN.

In RRC Connected mode, the UE receives the MM system information on the established RRC connection. (I.e. the broadcast MM system information is not used by the UE in the RRC connected mode.) An UE receiving information indicating a new LA, in state CS-IDLE and RRC Connected mode, shall initiate LA update towards the CN. An UE receiving information indicating a new RA, in state PS-IDLE and RRC Connected mode, shall initiate RA update towards the CN. An UE in state CS-CONNECTED and RRC Connected mode, shall not initiate LA update towards the CN. An UE in state PS-CONNECTED and RRC Connected mode, shall not initiate RA update towards the CN.

In CS-DETACHED mode the UE shall not initiate any LA update and this independent of the RRC mode. In PS-DETACHED mode the UE shall not initiate any RA update and this independent of the RRC mode.

In addition to normal location registration when changing registration area, the UE may (network options) perform CS periodic registration when in CS-IDLE state and PS periodic registration when in PS-IDLE state. The respective periodic registration may be on/off on LA respective RA level.

On the MM level, IMSI and CS related TMSI are used as UE identities in the CS domain, and IMSI and PS related TMSI are used as UE identities in the PS domain. The IMSI is the common UE identity for the two CN domains (CS and PS).

A signalling connection between the UE and the CN refers to a logical connection consisting of an RRC connection between UE and RAN and an Iu signalling connection (“one RANAP instance”) between the RAN and the CN node. The CS domain related signalling and PS domain related signalling uses one common RRC connection and two Iu signalling connections (“two RANAP instances”), i.e. one Iu signalling connection for the CS domain and one Iu signalling connection for the PS domain.

1) - 民 Use of combined procedures

The use of separated PS and CS mobility mechanisms within the UE and within the CN can lead to non-optimal usage of the radio resource (for example a UE in PS idle and CS idle state would perform both LA updates (for the CS mechanism) and RA updates (for PS mechanisms)).

To offer flexibility in the provision of MM, combined mechanisms can be used for LM purposes as well as for attach/detach status purposes.

A UE can perform combined update mechanisms. A CN should allow combined update operations (operator option). UEs should support the use of both combined and separate mechanisms.

NOTE: The support of this feature by all UEs will also ease evolution of MM in the future.

The RAN does not co-ordinate MM procedures that are logically between the CN and the MS. This includes: LM, authentication, temporary identity management and equipment identity check.

1). 濂 Description of the location management and mobility management concept – area concepts

1).-1. 澤 Introduction

For the mobility functionality four different area concepts are used. LA and RA in the CN as well as UTRAN Registration Area and Cell areas in the RAN.

1).. 炊 Location areas

For CS services, the CN uses LA. LA is used e.g. at CN initiated paging related to CS services. A CS service related temporary identity, CS –TMSI, may be allocated to the UE. This temporary identity is then unique within a LA.

1)- 1.. 爐 Routing areas

For PS services, the CN uses RA. RA is used e.g. at CN initiated paging related to PS services. A PS service related temporary identity, PS-TMSI, may be allocated to the UE. This temporary identity is then unique within a RA.

1).. 犁 RAN internal areas

RAN internal areas are used when the terminal is in RRC-Connected mode (see clause 6.7). The areas are used at e.g. RAN initiated paging. RAN internal area updating is a radio network procedure and the RAN internal area structure should not be visible outside the RAN. In RRC connected mode, the UE position is known on cell level or on URA level. RNTI is used as a temporary UE identifier used within the RAN and allocated at RRC connection establishment.

1).. 璩 Relationship between the different areas

The following area relations exist (see figure 6.3):

- there need not be any relation between URA and LA respectively between URA and RA. The URA concept is defined in 3G TS 25.331 [5];
- one RA consists of a number of cells belonging to RNCs that are connected to the same CN node;
- one LA consists of a number of cells belonging to RNCs that are connected to the same CN node;
- one RA is handled by only one CN serving node, i.e. one combined MSC+SGSN or one 3G_SGSN;
- one LA is handled by only one CN serving node, i.e. one combined MSC + SGSN or one 3G_MSC/VLR.

The GSM defined relations between LA and RA applies i.e. the following relations between LA and RA are possible:

- 1) RA and LA is equal;
- 1) one RA is a subset of one, and only one, LA, meaning that a RA do not span more than one LA.

The mapping between one LA and RNCs is handled within the MSC/VLR owning this LA. The mapping between one RA and RNCs is handled within the SGSN owning this RA. The mapping between LA and cells respective between RA and cells is handled within RNC.

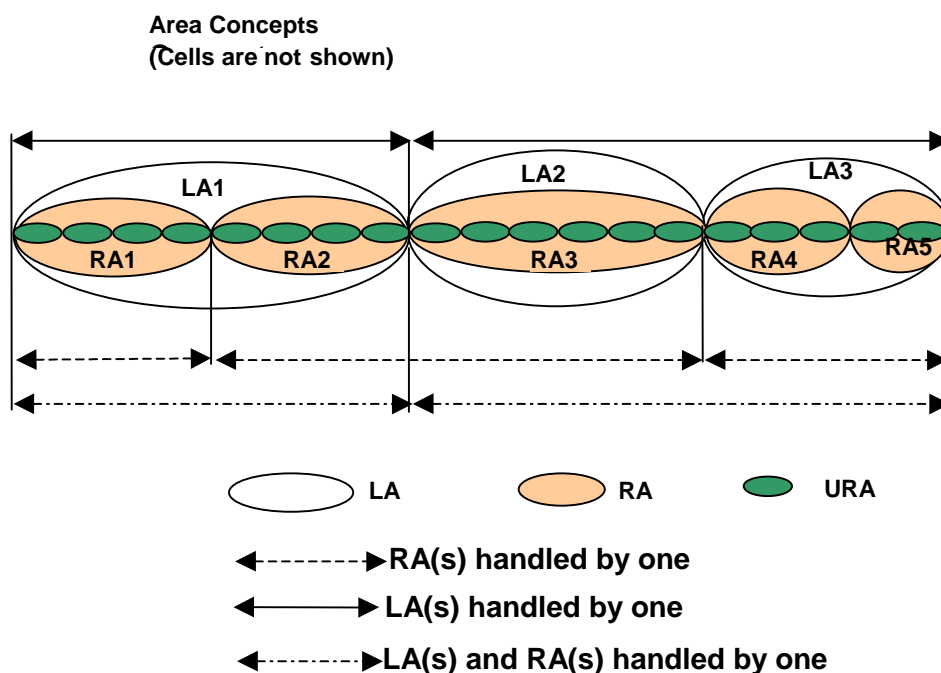

Figure 6.3: Relationship between different areas

1) 0.. 磯 Hierarchical tracking concept

A packet UE (in RRC connected mode) is tracked at the cell level by RNC during an active connection.

A packet UE (in RRC connected mode) is tracked at the URA level by RNC when no data are actively transfer, and the probability of data transfer is quite high.

A packet UE (in PS-Idle state) is tracked at the RA level by SGSN when no data is actively transferred and the probability of data transfer is quite low. The network operator can optimise paging and updating load by controlling the size of the different areas and the probability of data transfer (controlled by the RRC_connection_release timer). For example, one operator can decide that URA are small, and that RRC connection are released after a relatively short time of inactivity, so that most attached packet UE are tracked in the RA level (optimum for packet UE mainly using client-server type of service).

Another operator can decide that URA are large, and that RRC connection are released only if RRC connection is lost, so that most attached packet UE are tracked at the URA level.

The procedure for the releasing of the RRC connection can be found in 3G TS 23.060 [2] under the Iu release procedure. The URA update procedures can be found in 3G TS 25.331 [5].

1). 編 Relationship between MM and SM states for an UE

When a UE is attached to PS service, it may have, but need not have, some PDP context established.

If the UE has no PDP context established (SM-Inactive), no radio access bearer are established for PS service. The UE is in RRC connected mode, only if the state is CS-CONNECTED state or PS-CONNECTED state (i.e. only a PS signalling connection is established).

If the UE has at least one PDP context established (SM-Active), the UE can be in PS-CONNECTED state or in PS-IDLE state.

NOTE: The PDP context status is not modified by the release of the RRC connection, except if the release of the connection is due to an RRC failure which do not permit to maintain the negotiated QoS (e.g. a real time connection).

1). 脊 Requirement in case of temporarily loss of coverage of packet UE

A packet attached UE using non-real time bearer shall not lose its PDP context in case of temporarily loss of coverage. A UE specific Mobile Reachable Timer monitors how long PDP context(s) are kept after a UE has lost coverage.

1)0. 般 MM functionality in different UE service states

Below are the main UE service states and related MM functionality described.

CS service states and related MM functionality:

- 1) CS-DETACHED: The UE is not reachable by the network for CS services. The UE does not initiate LA updates at LA changes and no periodic CS service updates;
- 1) CS-IDLE: The UE is reachable by paging for CS services. The UE initiates LA updates at LA changes. The UE may initiate periodic CS service updates and this depends on the CS periodic update state of the present LA;
- 1) CS-CONNECTED: The UE has a signalling connection for CS services established between the UE and the CN. The UE does not initiate LA update (even not when the present LA changes) and no periodic CS service updates.

PS service states and related MM functionality:

- 1) PS-DETACHED: The UE is not reachable by the network for PS services. The UE does not initiate RA updates at RA changes and no periodic PS service updates;
- 1) PS-IDLE: The UE is reachable by paging for PS services. The UE initiates RA updates at RA changes. The UE may initiate periodic PS service updates and this depends on the PS periodic update state of the present RA;
- 1) PS-CONNECTED: The UE has a signalling connection for PS services established between the UE and the CN. The UE initiates RA update when RAI in MM system information changes. No periodic PS service updates.

There can also be a NULL state. In the UE, this state corresponds to power off or possibly a “no SIM” condition. In the CN, the NULL state correspond to CS-DETACHED and PS-DETACHED.

For each state transition there can be several events that triggers the transition. Some of them are described below.

NOTE: Some of these can coincide, e.g. moving from CS-IDLE to CS-DETACHED and moving from PS-IDLE to PS-DETACHED.

Moving from CS-IDLE to CS-CONNECTED:

The state transition from CS-IDLE to CS-CONNECTED is performed when a signalling connection is established between UE and CN for CS services. In GSM this state transition is triggered by the message CM_SERVICE_REQUEST or PAGE_RESPONSE.

Moving from CS-CONNECTED to CS-IDLE:

The state transition from CS-CONNECTED to CS-IDLE is performed when the signalling connection for CS services is released, e.g. at call release and no other CS service is ongoing. A radio link failure can also trigger this state transition.

Moving from CS-IDLE to CS-DETACHED:

The transition from CS-IDLE to CS-DETACHED can be triggered by some action from the user of the UE but an expiring timer in the network could also trigger it. The UE is marked as CS_DETACHED in the CN and then as a consequence no CS service establishment is possible.

Moving from PS-IDLE to PS-CONNECTED:

The state transition from PS-IDLE to PS-CONNECTED is performed when a signalling connection is established between UE and CN for PS services.

Moving from PS-CONNECTED to PS-IDLE:

The state transition from PS-CONNECTED to PS-IDLE is performed when the signalling connection for PS services is released, e.g. at release of a PS service, no other PS service is ongoing and at release of the RRC connection in case of very low level of activity. A radio link failure can also trigger this state transition.

Moving from PS-IDLE to PS-DETACHED:

The transition from PS-IDLE to PS-DETACHED can be triggered by some action from the user of the UE but an expiring timer in the network could also trigger it. The UE is marked as PS_DETACHED in the CN and then as a consequence no PS service establishment is possible.

1). 迂 The RRC state machine

The RRC state machine is a description model of how the UE and the RAN co-operate regarding RRC functionality. The RRC state describes the state of the UE in the RAN. Here follows a brief description of the RRC state machine, for more information see TS 25.301 [6] and TS 25.303 [7].

NOTE: RRC idle mode and RRC connected mode refer to the UE idle mode and UE connected mode respectively in TS 25.301 [6] and TS 25.303 [7].

The RRC state machine exists as peer entities, one in the UE and one in RAN. Apart from transient situations and error cases they are synchronised. Figure 6.4 illustrates the main modes/states of the RRC state machine.

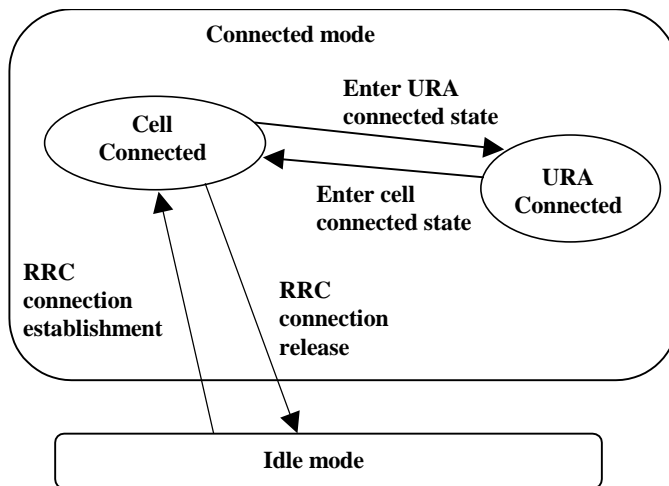

Figure 6.4: RRC modes, main RRC states and main mode/state transitions

RRC-Idle_mode:

In the Idle mode there is no connection established between UE and RAN. There is no signalling between RAN and the UE except for system information that is sent from RAN down link on a Broadcast channel to the UE. The UE can also receive paging messages with a CN identity on the PCH. There is no information on the UE stored in RAN in this state.

RRC-Connected_mode:

In the Connected mode the main states are Cell Connected state and URA connected state. In this mode there is one RNC that is acting as Serving RNC (SRNC), and an RRC connection is established between the UE and this SRNC.

- When the UE position is known on cell level, the UE is in the cell connected state. When in cell connected state, the RRC connection mobility is handled by handover procedures.
- When the UE position is known on URA level, the UE is in the URA connected state. The URA contains a set of cells. URA updating procedures provides the mobility functionality in this state. In URA connected state no dedicated radio resources are used.

1)-1. 雜 **Relationship between CS and PS service states and RRC state for an UE**

During non-transient conditions the following relations are valid between service states and RRC modes for an UE:

- 1) when in either CS-CONNECTED state or PS-CONNECTED state, or in both CS-CONNECTED state and PS-CONNECTED state, then the UE is in RRC connected mode;
- 1) when in neither CS-CONNECTED state nor PS-CONNECTED state, then the UE is in RRC idle mode.

Figure 6.5 and figure 6.6 illustrate two examples on the relations between the RRC states and CS/PS service states. These figures illustrate the separated CN case.

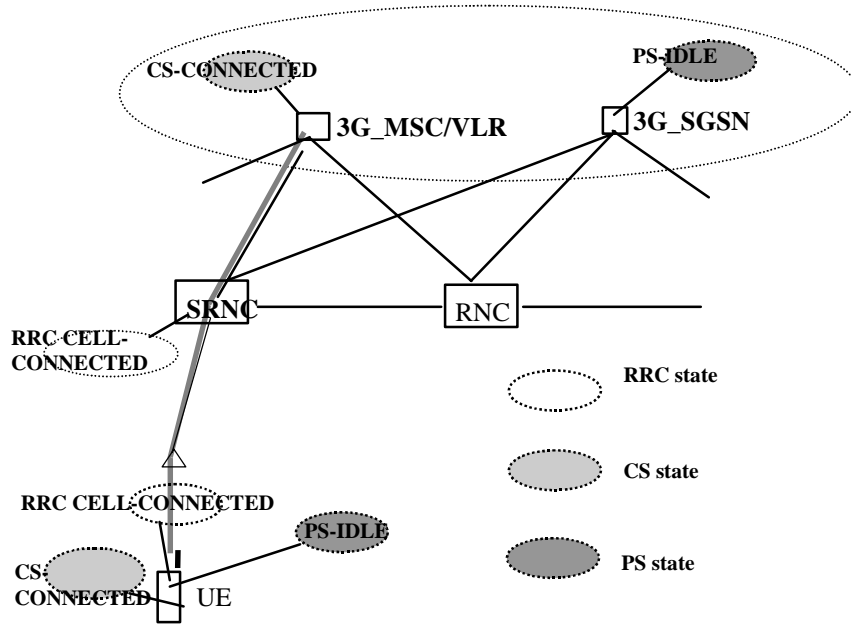

Figure 6.5: UE in CS-CONNECTED state and PS-IDLE state

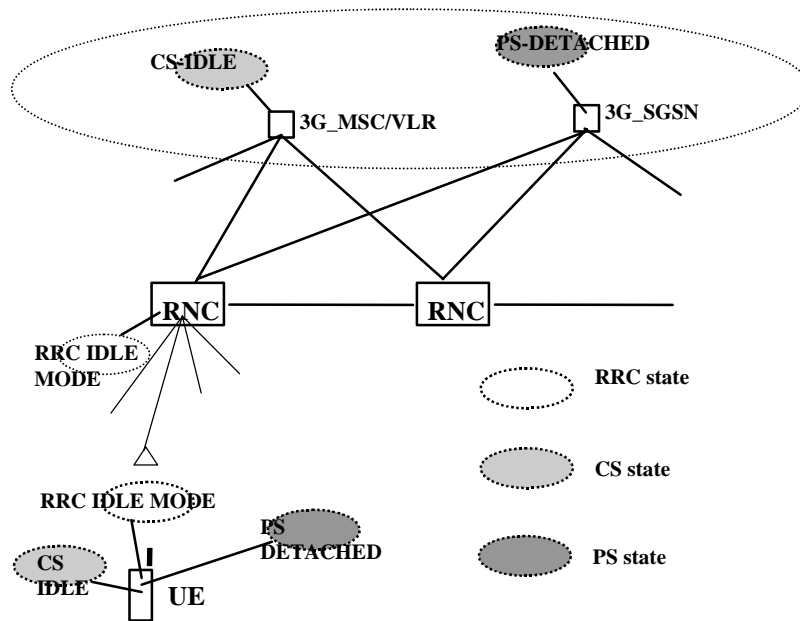

Figure 6.6

1)-1. 徽 Service registration and location update

1).. Introduction

Service registration (attach) in the respective CN domain is done initially (after UE being detached due to e.g. power off). When a registration area is changed a location update is performed. In addition, periodic registration can be performed. Here follows descriptions of when the respective CN registration area is changed.

NOTE: It is not here defined which different registration procedures that are needed.

1) - 1.. 缸 Location area update

Editor's note: Either the section could be removed completely or the first paragraph could be kept (including a reference to 23.012). Maybe the second alternative is the preferred one.

LA update is initiated by the UE to inform the CS domain of the CN that the UE has entered a new LA. In case the new LA is in an area served by another CN node, the LA update also triggers the registration of the subscriber in the new CN node and a location update for CS services towards the HLR.

LA update is only initiated by the UE when the UE is in state CS-IDLE, and this independently of the PS state. If the UE is CS-IDLE but RRC connected, which means that the UE is in PS-CONNECTED state, LA update is initiated by the UE when it receives information indicating a new LA.

1).. 鹹 Routing area update

RA update is initiated by the UE to inform the PS domain of the CN that the UE has entered a new RA. In case the new RA is in an area served by another CN node, the RA update also triggers the registration of the subscriber in the new CN node and a location update for PS services towards the HLR.

RA update is initiated by the UE when the UE is in state PS-IDLE, and this independently of the CS state. If the UE is PS-IDLE but RRC connected, which means that the UE is in CS-CONNECTED state, RA update is initiated by the UE when it receives information indicating a new RA.

When the UE is in PS-CONNECTED state the UE initiates RA update when RAI in MM system information changes.

1).. Combined updates

The GSM radio interface combined procedures and their support via the Gs interface is the starting point for the support of combined updates.

1). Paging initiated by CN

A CN node requests paging only for UE in CS-IDLE state or PS IDLE state. In the separate CN architecture, paging from a CN node is done independent of the service state of the UE in the other CN domain type.

Paging is co-ordinated within the UTRAN. Details on how the co-ordination is achieved and the parameters to be provided by the CN are specified in 3G TS 25.413 [9]. The procedures required between the UTRAN and UE are in 3G TS 25.331 [5].

In case of a single CN element, paging may be co-ordinated at the CN.

1). Signalling connection establishment

A signalling connection between the UE and a CN node refers here to a logical connection consisting of an RRC connection between UE and the RAN and an Iu signalling connection between the RAN and the CN node. The signalling connection is used for transfer of higher layer (MM, CM) information between the UE and the CN node.

At a CM service request to one of the CN domain types and when no such connection exists towards the applicable CN domain type, the UE shall request establishment of a new signalling connection.

If no RRC connection exists, this is established in conjugation with (before) the transfer of the signalling establishment request. At the RRC connection establishment, an UE context is built up in the SRNC.

If an RRC connection is already established, the UE shall send the signalling establishment request using that RRC connection.

At reception of the signalling establishment request, the SRNC will establish an Iu connection towards the CN node indicated by the CN service domain type received from UE.

1). Relations between SRNS relocation and location registration

This clause clarifies the need for separate handling of MM registration area (LA and RA) information in RRC idle mode respective in RRC connected mode. The following example illustrates relations between SRNC relocation, registration area (LA/RA) change and LA/RA updates. As shown in the example, this is equally applicable for a combined MSC + SGSN as well as the 3G-MSC/VLR and 3G-SGSN.

NOTE 1: The example is based on the assumptions that one RNC can set up Iu connections to only one 3G_MSC/VLR (or combined MSC+SGSN) and only one 3G_SGSN (or combined MSC+ SGSN), and that the CN node is configured to only send page to the RNC(s) that is controlling cells within the relevant LA/RA.

Preconditions (see figure 6.7):

- 1) LA1 is handled by 3G_MSC/VLR1 and LA2 is handled by 3G_MSC/VLR2 ;
- 1) RA1 is handled by 3G_SGSN1 and RA2 is handled by 3G_SGSN2 ;
- 1) UE is registered in LA1 in 3G_MSC/VLR1 and in RA1 in 3G_SGSN1;
- 1) the UE is in PS-CONNECTED state and a signalling connection exists between UE and 3G_SGSN1;
- 1) the UE is in CS-IDLE state and no signalling connection exists between UE and 3G_MSC/VLR1;
- 1) RNC1 is acting as SRNC and RNC2 is acting as DRNC;
- 1) UE is in RRC cell connected state and with dedicated channels established to cells within both RNC1 and RNC2. UE does not listening to the PCH;
- 1) the registration area information sent to the UE indicates LA1 and RA1.

The UE can always (at least in normal working states) identify the present available registration area (LA respective RA) associated with the respective CN domain. The determination of the present area differs depending on the state of the UE. For UE in RRC idle mode (UE with no ongoing communication with the network) it is the cell selection mechanism in the UE that is used. For UE in RRC connected mode it is the RAN that determines the area (although a change can implicit be initiated by the UE).

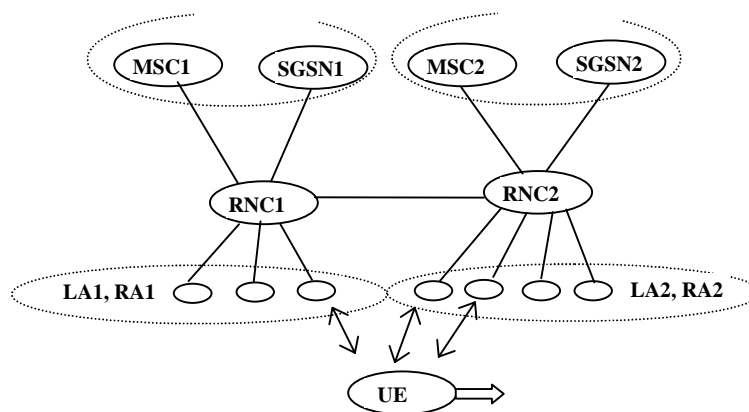

Figure 6.7: Illustration of the preconditions in the described example

In figure 6.7 MSC stands for 3G_MSC/VLR and SGSN for 3G_SGSN.

The UE moves now further towards the right, leaving the coverage area of cells controlled by RNC1, and resulting in that the UE has dedicated channel(s) established to cell(s) within only RNC2. This can result in the following sequence of events:

- 1) the SRNC (RNC1) can decide to perform an SRNC relocation resulting in that the RNC2 becomes SRNC. In this example, the change of SRNC also implies a change of SGSN with an update of the UE location registration for the PS domain;
- 1) after this SRNC relocation or combined with this procedure, the MM registration area information sent to the UE is changed and indicates now LA2 and RA2;

NOTE 2: The MM registration area information need not be sent for every SRNS relocation, nor does it preclude MM registration area information being sent in other occasions.

- 1) the UE initiates a LA update, which results in a registration change from LA1 in 3G_MSC/VLR1 to LA2 in 3G_MSC/VLR2 and results in changed MM registration information.

NOTE 3: The area information can not be changed to indicate LA2 unless SRNC relocation has been performed, because the LA update signalling is sent from the UE, by using the established RRC connection to SRNC, and then to the 3G_MSC/VLR to which the SRNC belongs.

1)-1. ㉞ Requirements on identifiers for UMTS and GSM

Editor's note: Need to be redrafted as requirements on equipment.

- 1a) The format of the UMTS Location Area Identifier and UMTS TMSI shall not prevent a dual mode GSM-UMTS mobile which was last location updated over the GSM radio interface (i.e. has a GSM LAI and GSM TMSI), from performing a location update (or other signalling) over the UMTS radio interface to a UMTS MSC.
- 1b) The format of the UMTS Location Area Identifier and UMTS TMSI shall not prevent a dual mode GSM-UMTS mobile which was last location updated over the UMTS radio interface (i.e. has a UMTS LAI and UMTS TMSI), from performing a location update (or other signalling) over the GSM radio interface to a GSM MSC.
- 1c) The format of the UMTS Routing Area Identifier and UMTS P-TMSI shall not prevent a dual mode GSM-UMTS mobile which was last routing area updated over the GSM radio interface (i.e. has a GSM RAI and GSM P-TMSI), from performing a routing area update (or other signalling) over the UMTS radio interface to a UMTS SGSN.
- 1d) The format of the UMTS Routing Area Identifier and UMTS P-TMSI shall not prevent a dual mode GSM-UMTS mobile which was last routing area updated over the UMTS radio interface (i.e. has a UMTS RAI and UMTS P-TMSI), from performing a routing area update (or other signalling) over the GSM radio interface to a GSM SGSN.
- 1) The standard shall support means by which an operator can configure GSM and UMTS cells to be members of the same registration area (i.e. the mobile can receive paging from whichever cell it is camped on and does not need to location update (or routing update) just because the mobile has changed from a UMTS to a GSM cell).
- 3a) The standard shall support means by which an operator can allocate GSM and UMTS LAIs which enable GSM MSCs to be able to contact UMTS MSCs and vice versa.
- 3b) The standard shall support means by which an operator can allocate GSM and UMTS RAIs which enable GSM SGSNs to be able to contact UMTS SGSNs and vice versa.
 - 1) The standard shall support means by which an operator can ensure that the IMSI does not need to be sent over the radio interface when the mobile station moves from a GSM cell to a UMTS cell (and vice-versa).
 - 1) The standard shall support means by which an operator can ensure that the IMSI does not need to be sent over the radio interface when a USIM is moved from a UMTS mobile station to a GSM mobile station (and vice-versa).
- 1) The standard need not support means by which an operator can ensure that the IMSI is not sent over the radio interface when a GSM SIM is moved from a GSM mobile station to a UMTS mobile station (and vice-versa).

1). Use of MM system information

In each cell the network broadcasts MM system information on the broadcast channel. . The “current MM system information” is used by the MM functionality in the UE respecting the rules for the UE service state of the respective MM state machine, see subclause 6.6. The “current MM system information” is identified as follows:

- 1) In RRC idle mode, when the UE camps on one cell, it receives all MM system information valid for this cell on the broadcast channel of the cell. The received MM system information is then the “current MM system information”;
- 1) In RRC connected mode, the SRNS shall control the current MM system information valid for the UE. E.g. at SRNS relocation, the new SRNS may send applicable MM system information to the UE. The established RRC connection shall be used for transferring any new MM system information to the UE. The UE shall use any new MM system information received from the SRNC on the established RRC connection as the “current MM system information”;

NOTE: The MM system information need not necessarily be sent for every SRNSs relocation, nor does it prelude MM system information being sent on other occasions.

- 1) At the RRC connection establishment, the UE uses the broadcasted MM system information of the cell where the establishment is made as the “current MM system information”;
- 1) When the UE leaves the RRC connected mode and enters RRC idle mode, the UE uses the broadcasted MM system information of the chosen cell, which is determined by the UE idle mode cell selection/re-selection process that is then performed, as the “current MM system information”;

1)-1. Signalling procedures

1).. Idle mode procedures

The signalling procedures shown in the following clauses do not represent the complete set of possibilities, nor do they mandate this kind of operation. This document specifies a set of elementary procedures for each interface, which can be combined in different ways in an implementation. Therefore these sequences are merely examples of a typical implementation. By default the combined procedures as defined in TS 23.060 [2] are also applicable when using Gs.

The list of parameters should be regarded as examples of possible information carried by the messages and not as a complete list.

1).-1.. . .□ Location Area update

Figure 6.8 shows location registration when changing LA including change of 3G-MSC/VLR and when the UE is in MM idle state towards the 3G_MSC/VLR.

The illustrated transfer of MM signalling to/from the UE uses an established RRC connection. This RRC connection can have been established beforehand due to ongoing interwork between UE and 3G-SGSN or be established only for this location registration procedure towards the 3G_MSC/VLR.

For each indicated MM message sent in this case to/from UE, the CN discriminator indicates 3G_MSC/VLR.

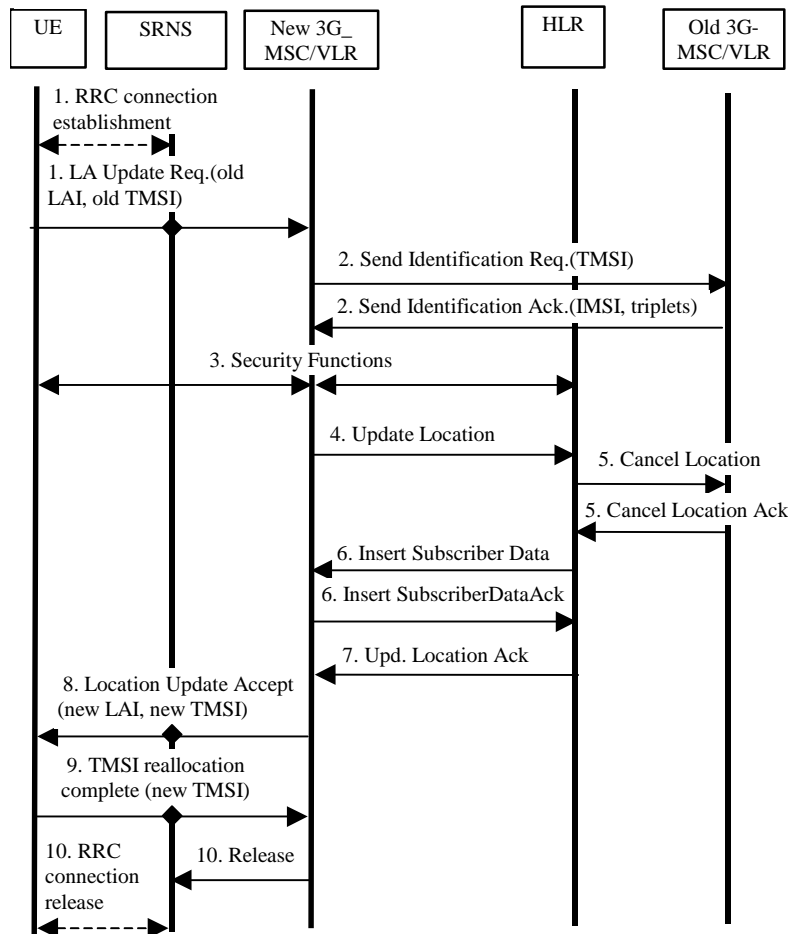

Figure 6.8: Interface information transfer for location update when changing VLR area

- 1) The RRC connection is established, if not already done. The UE sends the initial message LA Update Request (old TMSI, old LAI, etc.) to the new 3G_MSC/VLR. The old TMSI and the old LAI are assigned data in UMTS. The SRNS transfers the message to the 3G_MSC/VLR

Editor's Note: The sentence "The old TMSI and the old LAI are assigned data in UMTS." Is meaningless..

NOTE: The sending of this message to 3G_MSC/VLR also implies establishment of a signalling connection between SRNS and 3G_MSC/VLR for the concerned UE.

The RAN shall add the RAC and the LAC of the cell where the message was received before passing the message to the MSC.

- 1) The new 3G_MSC/VLR sends an Send Identification Request (old TMSI) to the old 3G_MSC/VLR to get the IMSI for the UE. (The old LAI received from UE is used to derive the old 3G_MSC/VLR identity/address.) The old 3G_MSC/VLR responds with Send Identification Ack. (IMSI and Authentication triplets).
- 1) Security functions may be executed.
- 1) The new 3G_MSC/VLR inform the HLR of the change of 3G_MSC/VLR by sending Update Location (IMSI, MSC address, VLR number) to the HLR.
- 1) The HLR cancels the context in the old 3G_MSC/VLR by sending Cancel Location (IMSI). The old 3G_MSC/VLR removes the context and acknowledges with Cancel Location Ack.
- 1) The HLR sends Insert Subscriber Data (IMSI, subscription data) to the new 3G_MSC/VLR. The new 3G_MSC/VLR acknowledges with Insert Subscriber Data Ack.
- 1) The HLR acknowledges the Update Location by sending Update Location Ack. To the new 3G_MSC/VLR.

- 1) The new 3G_MSC/VLR validates the UE presence in the new LA. If due to regional, national or international restrictions the UE is not allowed to attach in the LA or subscription checking fails, then the new 3G_MSC/VLR rejects the LA update with an appropriate cause. If all checks are successful, then the new 3G_MSC/VLR responds to the UE with LA Update Accept (new TMSI, new LAI).
- 1) The UE acknowledges the new TMSI with a TMSI reallocation Complete. (TMSI can optionally be reallocated with the TMSI reallocation procedure).
- 1) When the location registration procedure is finished, the 3G_MSC/VLR can release the signalling connection towards the SRNS for the concerned UE. The SRNS shall then release the RRC connection if there is no signalling connection between 3G_SGSN and SRNS for the UE.

1)... . □ 품 Routing Area Update

The routing area update procedure is detailed in 3G TS 23.060[2].

1).-1.. . □ 품 Periodic registration towards both CN nodes without use of Gs

Periodic registration for the CS domain is specified in 3G TS 23.012 [3]. Periodic registration for the PS domain is covered in 3G TS 23.060 [2]. In the case of a combined node, this procedure does not apply.

1).-1.. . □ 형 Periodic registration with use of Gs or combined MSC+SGSN node

Periodic registration for the PS domain is covered in 3G TS 23.060 [2]. Only RA Update req. registration is required from the UE to the 3G-3G-SGSN. This procedure applies for a combined 3G-MSC/3G-SGSN.

1).-1.. . □ 획 UE initiated combined detach procedure when using Gs or combined MSC+SGSN node

UE initiated Combined Detach Procedure when using Gs or combined MSC+SGSN node is specified in 3G 23.060 [2]. The UE specifies which form of detach is required, i.e., PS Detach only, CS Detach only or combined Detach..

1).. . . . SRNS Relocation

SRNS relocation is covered in 25.413 [9] and 3G TS 23.060 [2].

NOTE: Examples of RAN signalling are given in TR 25.931 [15].

1). RAN coordination

The RAN coordinates the resource allocation of an UE attached to both PS and CS services. The UTRAN shall reject or downgrade a connection which cannot be granted, see 3G TS 23.060 [2]. The cause might be congestion on the radio interface, or the existence of other connections between this UE and the other CN.

The RAN uses the IMSI to identify a UE. The IMSI is transferred from the CN to the RAN with the common ID procedure. When an Iu connection is established, the CN shall perform the RANAP common ID procedure toward RAN as soon as the UE is identified (IMSI). The IMSI is only stored in the RAN for the duration of the RRC Connection.

There are two functions that are co-ordinated.

- 1) Paging coordination is described in 5.9.1 of 25.410 [10]; and
- 1) Relocation coordination that is described in 8.7.5 in 25.413 [9].

1) Call control

1)-1. General Aspects

The following technical requirements are applied to support multimedia in GSM/UMTS.

- 1) GSM/UMTS shall enable the provisioning of multimedia services and multivendor interworking between UE and network.
- 1) Handover and roaming to and from GSM shall be supported provided GSM is capable of supporting the ongoing media service.
- 1) For multimedia services the standardized multimedia protocol shall be run transparently via a PDP-context or a CS connection established using GSM SM/CC . This allows transparent hand-over and roaming between GSM and UMTS provided that GSM supports the QoS requirements.
- 1) SIP from the IETF shall be the multimedia call control supported over the PS domain, where the network functional entities for multimedia support are within the PLMN.

NOTE: Other multimedia protocols can be supported e.g. H.323 transparently over the PS domain . In these cases, the multimedia functional entities shall be outside of the PLMN. Support of terminating calls for these protocols are outside the scope of these specifications.

- 1) H.324M shall be supported within the CS domain.

Figure 7.1 illustrates the realisation of the multimedia service based on requirement 3. ‘Multimedia Protocol’ indicates the functionality either inside the communicating user’s terminal or a server (e.g. SIP server). It is essentially a control function both for user plane and control plane for the multimedia communication.

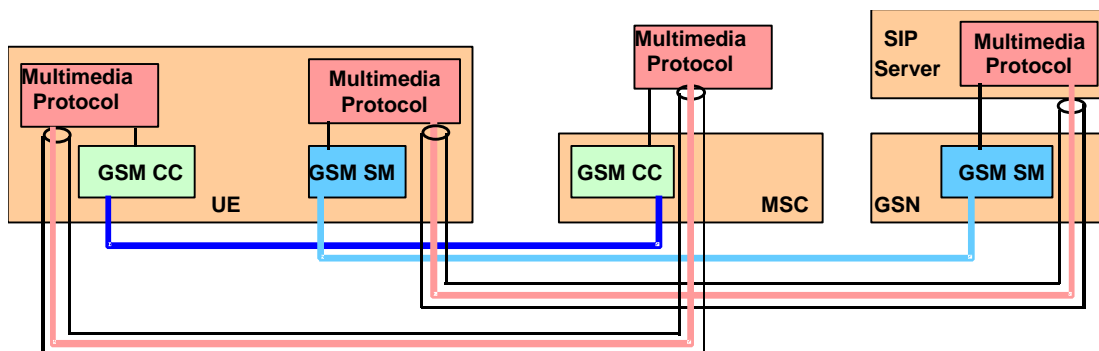

Figure 7.1: Support of multimedia making use of GSM SM/CC

Annex A (informative): Change history

Change history							
Date	TSG #	TSG Doc.	CR	Rev	Subject/Comment	Old	New
					Version 0.0.1 Is version 3.4.0 of 23.121 incorporated into the new document template but reflecting changes to the document number and title. This version therefore also incorporates approved CR060 to 23.121		
					Version 0.0.2 incorporates approved CR056 to 23.121		
					Version 0.0.3 incorporates additions and deletions according to		

				annex B		
				Version 0.0.4 makes no changes to the V.003 text, but moves the clauses into the new layout. There are therefore no revision marks in this version. Hanging paragraphs have had new clause headers added. Figures have been renumbered.		
				Version 0.0.5 amends the scope, adds references. Ensures all figures are referenced in text. Remaining release 99 references deleted.		
				Version 0.1.0 incorporates the changes agreed at S2#15. a) The scope has been expanded to allow the inclusion of high level CS domain issues.		
Dec 2000	SA#10			Version 1.0.0 produced for presentation to SA#10. Same content as v.0.1.0		1.0.0
Jan2000	SA#16	S2-010159		Version 1.0.1 incorporates changes proposed on mailing list.		1.0.1
Jan2000	SA2#16	S2-010314		Incorporates changes from SA#16		1.1.0
Feb 2000				Creation of a version with Release 4 requirements only	1.1.0	1.1.1
Mar 2000	SA2#17	S2-010733		Incorporation of agreed changes in s2-010741 and s2-010639	1.1.1	1.2.0
Mar 2000	SA #11	SP-010122		Version 2.0.0, same technical content as v.1.2.0	1.2.0	2.0.0