

**3GPP TSG-CN-WG1, Meeting #15
15-19 January 2001, Beijing, China**

Tdoc N1-010211

From: TSG CN WG1

To: TSG CN WG4, TSG SA WG1, TSG GERAN WG2

CC: TSG SA, TSG CN

Title: LS on Problem with GPRS and Roaming

Date: 18-January-2001

Contact: Sophie Aveline, France Telecom [sophie.aveline@francetelecom.fr]

Attachments: N1-010216, (04.08 CR)
N1-010215, N1-010223 (03.22 CRs)

(Please list documents numbers to be attached)

During TSG CN Plenary #10 and during TSG SA Plenary #10, Tdoc NP-00697 and Tdoc SP-00666 respectively raise the same very important problem concerning GPRS and roaming situation. This problem, which has been experienced from the deployment of GPRS in live networks, has been further analysed by TSG CN WG1 and can be summarised as follows:

Operator A has a Roaming agreement with operator B, but only for Circuit Switched services not for GPRS (both networks supporting GPRS).

The customer moves from operator A's coverage to operator B's coverage. Operator B should accept that customer's attach/registration attempts on network B for circuit switched services, but should reject the GPRS attach.

Instead of such behaviour, two different implementations have been identified:

- *According to 3GPP specifications, the customer is denied from the whole operator B's network (CS and PS domains) (error cause #11 "PLMN not allowed" of TS 04.08 R'97)*
- *A manufacturer's specific implementation tries to avoid such problem sending another error cause value (#7 "GPRS service not allowed" of TS 04.08 R'97), but according to the TS 04.08 the MS is not allowed to try anymore to attach to a PS domain of any GSM network unless it is switched off and on.*

Consequently, if there is only a roaming agreement for CS services but not for PS service (GPRS) with the visited network, there does not exist any suitable cause value with which PS attach can be rejected without impact on both the GSM services and the GPRS services in other networks.

In order to solve the problem a **new rejection cause** value "**GPRS services not allowed in this PLMN**"(#14) has been introduced. This new rejection cause can be sent to the MS during GPRS attach, detach and RAU if a visited PLMN does not offer GPRS roaming to that MS. A list of "forbidden PLMNs for GPRS service" has been introduced in 03.22(23.122) which must at least consist of one entry.

**3GPP TSG-CN-WG1, Meeting #15
15-19 January 2001, Beijing, China**

Tdoc N1-010211

Relevant CRs have been agreed by CN1 to 04.08 and 03.22 for all releases from R97 onwards. Attached to this liaison is Tdoc N1-010216 containing the CR on 04.08 Release 97 (the companion CRs are in Tdoc N1-010219, Tdoc N1-010220 and Tdoc N1-010221). The CR on TS 03.22 R97 is attached to this liaison in Tdoc N1-010215 (the companion CRs are in Tdoc N1-010223 and Tdoc N1-010224).

1. TSG CN WG1 would like to ask TSG CN WG4 to proceed with the necessary work under their responsibility to support this solution to solve this GPRS roaming problem.
2. TSG CN WG1 would like to ask TSG SA WG1 to proceed to the relevant modifications, if needed, to TS 02.11 R'97, TS 02.11 R'98, TS 22.011 R'99 and 22.011 R4 as the corresponding stage 3 needed some modifications for the implementation of the solution of this GPRS roaming problem. The relevant CR on TS 03.22 Release 97 is attached to this liaison in Tdoc N1-010215 (the companion CRs are in Tdoc N1-010223 and Tdoc N1-010224).
3. TSG CN WG1 would like to ask TSG GERAN WG2 to endorse the CRs on 03.22 as TSG GERAN WG2 has the prime responsibility for 03.22.

15-19 January 2001, Beijing, China

CR-Form-v3

CHANGE REQUEST⌘ **04.08 CR A1081** ⌘ rev **2** ⌘ Current version: **6.13.0** ⌘For **HELP** on using this form, see bottom of this page or look at the pop-up text over the ⌘ symbols.Proposed change affects: ⌘ (U)SIM ME/UE Radio Access Network Core Network

Title:	⌘ Roaming restrictions for GPRS service		
Source:	⌘ Siemens AG		
Work item code:	⌘ GPRS	Date:	⌘ 2000-01-15
Category:	⌘ F	Release:	⌘ R97
Use <u>one</u> of the following categories: F (essential correction) A (corresponds to a correction in an earlier release) B (Addition of feature), C (Functional modification of feature) D (Editorial modification) Detailed explanations of the above categories can be found in 3GPP TR 21.900.		Use <u>one</u> of the following releases: 2 (GSM Phase 2) R96 (Release 1996) R97 (Release 1997) R98 (Release 1998) R99 (Release 1999) REL-4 (Release 4) REL-5 (Release 5)	

Reason for change:	⌘ Experience from the deployment of GPRS in live networks brought out that some existing roaming scenarios and configurations does not work. In the case when operator has only roaming agreement for CS services but not for PS service (GPRS) there is no suitable cause value with which PS attach can be rejected without impact on both the GSM roaming and the GPRS services in other networks. More detail description of the problem can be found from TSG CN Plenary #14 Tdoc NP-000697 and TSG SA Plenary #10 Tdoc SP-000666.
Summary of change:	⌘ In order to solve the problem it is proposed to introduce a new rejection cause value "GPRS services not allowed in this PLMN" (#14) that could be indicated to the MS during GPRS attach, detach and RAU in a PLMN which does not offer GPRS roaming to that MS. When MS receives this cause code it shall not attempt new GPRS attach before entering a new PLMN on which it hasn't be rejected with the same cause after the last switch on. In order to memorise the PLMNs on which the MS is already rejected with #14, a new PLMN list is introduced, which should be deleted when the MS is switched off. The list is introduced in order to avoid subsequent registration attempts which could occur if either the MS(in class C mode), or the user(in class A/B mode) triggers a PLMN reselection after reception of #14.
Consequences if not approved:	⌘ If no roaming agreement is established for GPRS or the SGSN has no knowledge about the HLR of the roaming subscriber, depending on the SGSN implementation either #11 or #7 will probably send to the MS which disables in minimum the PS until the MS is switched off. The only other possibility would be that the network sends a cause code not listed explicitly, with the consequence that the MS will try to register "forever" (5 re-attempts after each T3302 expiry)

which causes a considerable network load and results in a unacceptable behaviour from the users point of view(long term no service and battery consumption)

Clauses affected:	⌘	4.7.3.1.4; 4.7.3.2.4; 4.7.4.2.2; 4.7.5.1.4; 4.7.5.2.4; 10.5.5.14; G.6	
Other specs affected:	⌘	<input checked="" type="checkbox"/> Other core specifications <input type="checkbox"/> Test specifications <input type="checkbox"/> O&M Specifications	⌘ 03.22 A??? "Roaming restrictions for GPRS service"
Other comments:	⌘		

4.7.3.1.4 GPRS attach not accepted by the network

If the attach request cannot be accepted by the network, an ATTACH REJECT message is transferred to the MS. The MS receiving the ATTACH REJECT message stops timer T3310 and takes one of the following actions depending upon the reject cause:

3 (Illegal MS); or

6 (Illegal ME)

The MS shall set the GPRS update status to GU3 ROAMING NOT ALLOWED (and shall store it according to section 4.1.3.2) and shall delete any P-TMSI, P-TMSI signature, RAI and GPRS ciphering key sequence number. The new GMM state is GMM-DEREGISTERED. The SIM shall be considered as invalid for GPRS services until switching off or the SIM is removed.

If the MS is IMSI attached via MM procedures, the MS shall in addition set the update status to U3 ROAMING NOT ALLOWED, shall delete any TMSI, LAI and ciphering key sequence number. The new MM state is MM IDLE. The SIM shall be considered as invalid also for non-GPRS services until switching off or the SIM is removed.

7 (GPRS services not allowed)

The MS shall set the GPRS update status to GU3 ROAMING NOT ALLOWED (and shall store it according to section 4.1.3.2) and shall delete any P-TMSI, P-TMSI signature, RAI and GPRS ciphering key sequence number. The SIM shall be considered as invalid for GPRS services until switching off or the SIM is removed. The new state is GMM-DEREGISTERED.

8 (GPRS services and non-GPRS services not allowed)

The MS shall set the GPRS update status to GU3 ROAMING NOT ALLOWED (shall store it according to section 4.1.3.2) and shall delete any P-TMSI, P-TMSI signature, RAI and GPRS ciphering key sequence number. The new GMM state is GMM-DEREGISTERED. The new MM state is MM IDLE.

The MS shall set the update status to U3 ROAMING NOT ALLOWED, shall delete any TMSI, LAI and ciphering key sequence number. The SIM shall be considered as invalid for GPRS and non-GPRS services until switching off or the SIM is removed.

11 (PLMN not allowed)

12 (Location area not allowed); or

13 (Roaming not allowed in this location area)

The MS shall delete any RAI, P-TMSI, P-TMSI signature, and GPRS ciphering key sequence number stored, shall set the GPRS update status to GU3 ROAMING NOT ALLOWED (and shall store it according to section 4.1.3.2), shall reset the GPRS attach attempt counter and shall change to state GMM-DEREGISTERED.

If the MS is IMSI attached via MM procedures, the MS shall in addition set the update status to U3 ROAMING NOT ALLOWED, shall delete any TMSI, LAI and ciphering key sequence number and shall reset the location update attempt counter. The new MM state is MM IDLE.

The MS shall store the LAI or the PLMN identity in the appropriate forbidden list, i.e. in the "forbidden PLMN list" for cause #11, in the list of "forbidden location areas for regional provision of service" for cause #12 or in the list of "forbidden location areas for roaming" for cause #13. If cause #11 or #13 was received, the MS shall perform a PLMN selection instead of a cell selection.

14 (GPRS services not allowed in this PLMN)

The MS shall delete any RAI, P-TMSI, P-TMSI signature, and GPRS ciphering key sequence number stored, shall set the GPRS update status to GU3 ROAMING NOT ALLOWED (and shall store it according to section 4.1.3.2) and shall change to state GMM-DEREGISTERED.

The MS shall store the PLMN identity in the "forbidden PLMNs for GPRS service" list. A GPRS MS operating in MS operation mode C shall perform a PLMN selection instead of a cell selection.

A GPRS MS operating in MS operation mode A or B in network operation mode II or III, is still IMSI attached for CS services in the network.

Other values are considered as abnormal cases. The specification of the MS behaviour in those cases is specified in section 4.7.3.1.5.

4.7.3.2.3.2 Combined attach successful for GPRS services only

The description for IMSI attach for GPRS services as specified in section 4.7.3.1.3 shall be followed. In addition, the following description for IMSI attach for non-GPRS services applies.

The MS receiving the ATTACH ACCEPT message takes one of the following actions depending on the reject cause:

2 (IMSI unknown in HLR)

The MS shall set the update status to U3 ROAMING NOT ALLOWED and shall delete any TMSI, LAI and ciphering key sequence number. The new MM state is MM IDLE. The SIM shall be considered as invalid for non-GPRS services until switching off or the SIM is removed.

- # 16 (MSC temporarily not reachable)
- # 17 (Network failure); or
- # 22 (Congestion)

The MS shall change to state GMM-REGISTERED.ATTEMPTING-TO-UPDATE-MM. Timer T3310 shall be stopped if still running. The routing area updating attempt counter shall be incremented.

If the routing area updating attempt counter is less than 5, and the stored RAI is equal to the RAI of the current serving cell and the GMM update status is equal to GU1 UPDATED:

- the MS shall keep the GMM update status GU1 UPDATED and changes state to GMM-REGISTERED.ATTEMPTING-TO-UPDATE-MM. The MS shall start timer T3311. When timer T3311 expires the combined routing area update procedure indicating “combined RA/LA updating with IMSI attach” is triggered again.

If the routing area updating attempt counter is greater than or equal to 5:

- the MS shall start timer T3302 and shall change to state GMM-REGISTERED.ATTEMPTING-TO-UPDATE-MM;
- a GPRS MS operating in MS operation mode A shall then proceed with appropriate MM specific procedure; a GPRS MS operating in MS operation mode B may then proceed with appropriate MM specific procedures. The MM sublayer shall act as in network operation mode II as long as the combined GMM procedures are not successful and no new RA is entered. The new MM state is MM IDLE.

Other values are considered as abnormal cases. The combined attach procedure shall be considered as failed for GPRS and non-GPRS services. The behaviour of the MS in those cases is specified in section 4.7.3.2.5.

4.7.3.2.4 Combined GPRS attach not accepted by the network

If the attach request can neither be accepted by the network for GPRS nor for non-GPRS services, an ATTACH REJECT message is transferred to the MS. The MS receiving the ATTACH REJECT message stops timer T3310 and takes one of the following actions depending upon the reject cause:

- # 3 (Illegal MS);
- # 6 (Illegal ME); or
- # 8 (GPRS services and non-GPRS services not allowed).

The MS shall set the GPRS update status to GU3 ROAMING NOT ALLOWED (shall store it according to section 4.1.3.2) and shall delete any P-TMSI, P-TMSI signature, RAI and GPRS ciphering key sequence number. The new GMM state is GMM-DEREGISTERED. The new MM state is MM IDLE.

The MS shall set the update status to U3 ROAMING NOT ALLOWED, shall delete any TMSI, LAI and ciphering key sequence number. The SIM shall be considered as invalid for GPRS and non-GPRS services until switching off or the SIM is removed.

7 (GPRS services not allowed).

The MS shall set the GPRS update status to GU3 ROAMING NOT ALLOWED (and shall store it according to section 4.1.3.2) and shall delete any P-TMSI, P-TMSI signature, RAI and GPRS ciphering key sequence number. The SIM shall be considered as invalid for GPRS services until switching off or the SIM is removed.

The new GMM state is GMM-DEREGISTERED; the MM state is MM IDLE. A GPRS MS operating in MS operation mode A shall then perform an IMSI attach for non-GPRS services by use of the MM IMSI attach procedure; a GPRS MS operating in MS operation mode B shall then perform an IMSI attach for non-GPRS services by use of the MM IMSI attach procedure.

11 (PLMN not allowed);

12 (Location area not allowed); or

13 (Roaming not allowed in this location area).

The MS shall delete any RAI, P-TMSI, P-TMSI signature and GPRS ciphering key sequence number stored, shall set the GPRS update status to GU3 ROAMING NOT ALLOWED (and shall store it according to section 4.1.3.2), shall reset the routing area updating attempt counter and reset the GPRS attach attempt counter and changes to state GMM-DEREGISTERED. The MS shall set the update status to U3 ROAMING NOT ALLOWED, reset the location update attempt counter and shall delete any TMSI, LAI and ciphering key sequence number. The new MM state is MM IDLE.

The MS shall store the LAI or the PLMN identity in the appropriate forbidden list, i.e. in the “forbidden PLMN list” for cause #11, in the list of “forbidden location areas for regional provision of service” for cause #12 or in the list of “forbidden location areas for roaming” for cause #13. If cause #11 or #13 was received, the MS shall perform a PLMN selection instead of a cell selection.

14 (GPRS services not allowed in this PLMN)

The MS shall delete any RAI, P-TMSI, P-TMSI signature, and GPRS ciphering key sequence number stored, shall set the GPRS update status to GU3 ROAMING NOT ALLOWED (and shall store it according to section 4.1.3.2) and shall change to state GMM-DEREGISTERED.

The MS shall store the PLMN identity in the "forbidden PLMNs for GPRS service" list.

A GPRS MS operating in MS operation mode A or B shall then perform an IMSI attach for non-GPRS services by use of the MM IMSI attach procedure.

Other values are considered as abnormal cases. The specification of the MS behaviour in those cases is specified in section 4.7.3.2.5.

4.7.4.2.2 Network initiated GPRS detach procedure completion by the MS

When receiving the DETACH REQUEST message and the detach type IE indicates “re-attach not required” or “re-attach required”, the MS shall deactivate the PDP contexts and deactivate the logical link(s), if any. The MS shall then send a DETACH ACCEPT message to the network and shall change state to GMM-DEREGISTERED. The MS shall, after the completion of the GPRS detach procedure, initiate a GPRS attach procedure if indicated by the network in the detach type IE.

A GPRS MS operating in MS operation mode A or B in network operation mode I, which receives an DETACH REQUEST message with detach type indicating "re-attach required" or "re-attach not required" and no cause code, is only detached for GPRS services in the network.

When receiving the DETACH REQUEST message and the detach type IE indicates “IMSI detach”, the MS shall not deactivate the PDP contexts. A MS in operation mode A or B in network operation mode I may send a DETACH ACCEPT message to the network., and shall re-attach to non-GPRS service by performing the combined routing area updating procedure, sending a ROUTING AREA UPDATE REQUEST message with Update type IE indicating "combined RA/LA updating with IMSI attach". A MS in operation mode C, or in MS operation mode A or B in network operation mode II or III, shall send a DETACH ACCEPT message to the network.

If the detach type IE indicates “IMSI detach” or “re-attach required”, then the MS shall ignore the cause code if received.

If the detach type information element value indicates "re-attach required" or "re-attach not required" and the MS is attached for GPRS and non-GPRS services and the network operates in network operation mode I, then if in the MS the timer T3212 is not already running, the timer T3212 shall be set to its initial value and restarted.

If the detach type IE indicates "re-attach required", the MS shall perform a new attach procedure. The MS should also activate PDP context(s) to replace any previously active PDP contexts.

NOTE: In some cases, user interaction may be required and then the MS cannot activate the PDP context(s) automatically.

If the detach type IE indicates "re-attach not required", then, depending on the received cause code, the MS shall act as follows:

2 (IMSI unknown in HLR)

The MS shall set the update status to U3 ROAMING NOT ALLOWED and shall delete any TMSI, LAI and ciphering key sequence number. The new MM state is MM IDLE. The SIM shall be considered as invalid for non-GPRS services until switching off or the SIM is removed. A GPRS MS operating in MS operation mode A or B in network operation mode I, is still IMSI attached for GPRS services in the network.

3 (Illegal MS); or

6 (Illegal ME).

The MS shall set the GPRS update status to GU3 ROAMING NOT ALLOWED (and shall store it according to section 4.1.3.2) and shall delete any P-TMSI, P-TMSI signature, RAI and GPRS ciphering key sequence number. The new GMM state is GMM-DEREGISTERED. The SIM shall be considered as invalid for GPRS services until switching off or the SIM is removed.

A GPRS MS operating in MS operation mode A or B shall in addition set the update status to U3 ROAMING NOT ALLOWED, shall delete any TMSI, LAI and ciphering key sequence number. The new MM state is MM idle. The SIM shall be considered as invalid also for non-GPRS services until switching off or the SIM is removed.

7 (GPRS services not allowed)

The MS shall set the GPRS update status to GU3 ROAMING NOT ALLOWED (and shall store it according to section 4.1.3.2) and shall delete any P-TMSI, P-TMSI signature, RAI and GPRS ciphering key sequence number. The SIM shall be considered as invalid for GPRS services until switching off or the SIM is removed. The new state is GMM-DEREGISTERED.

A GPRS MS operating in MS operation mode A or B in network operation mode I shall set the timer T3212 to its initial value and restart it, if it is not already running.

A GPRS MS operating in MS operation mode A or B in network operation mode I, is still IMSI attached for CS services in the network.

8 (GPRS services and non-GPRS services not allowed).

The MS shall set the GPRS update status to GU3 ROAMING NOT ALLOWED and the update status to U3 ROAMING NOT ALLOWED (and shall store it according to section 4.1.3.2). Furthermore, it shall delete any P-TMSI, P-TMSI signature, TMSI, RAI, LAI, ciphering key sequence number and GPRS ciphering key sequence number and shall consider the SIM as invalid for GPRS and non-GPRS services until switching off or the SIM is removed.

11 (PLMN not allowed);

12 (Location area not allowed); or

13 (Roaming not allowed in this location area).

The MS shall delete any RAI or LAI, P-TMSI, P-TMSI signature and GPRS ciphering key sequence number, shall set the GPRS update status to GU3 ROAMING NOT ALLOWED (and shall store it according to section 4.1.3.2).

A GPRS MS operating in MS operation mode A or B shall in addition set the update status to U3 ROAMING NOT ALLOWED and shall delete any TMSI, LAI and ciphering key sequence number. The new MM state is MM IDLE.

The MS shall store the LAI or the PLMN identity in the appropriate forbidden list, i.e. in the “forbidden PLMN list” for cause #11, in the list of “forbidden location areas for regional provision of service” for cause #12 or in the list of “forbidden location areas for roaming” for cause #13. If #11 or #13 was received, the MS shall perform a PLMN selection instead of a cell selection.

14 (GPRS services not allowed in this PLMN)

The MS shall delete any RAI, P-TMSI, P-TMSI signature, and GPRS ciphering key sequence number stored, shall set the GPRS update status to GU3 ROAMING NOT ALLOWED (and shall store it according to section 4.1.3.2) and shall change to state GMM-DEREGISTERED.

The MS shall store the PLMN identity in the "forbidden PLMNs for GPRS service" list.

A GPRS MS operating in MS operation mode A or B in network operation mode I shall set the timer T3212 to its initial value and restart it, if it is not already running.

A GPRS MS operating in MS operation mode A or B, is still IMSI attached for CS services in the network.

Other cause values shall not impact the update status. Further actions of the MS are implementation dependent.

4.7.5.1.4 Normal and periodic routing area updating procedure not accepted by the network

If the routing area updating cannot be accepted, the network sends a ROUTING AREA UPDATE REJECT message to the MS. An MS that receives a ROUTING AREA UPDATE REJECT message stops timer T3330. The MS shall then take different actions depending on the received reject cause value:

3 (Illegal MS); or

6 (Illegal ME).

The MS shall set the GPRS update status to GU3 ROAMING NOT ALLOWED (and shall store it according to section 4.1.3.2) and enter the state GMM-DEREGISTERED. Furthermore, it shall delete any P-TMSI, P-TMSI signature, RAI and GPRS ciphering key sequence number and shall consider the SIM as invalid for GPRS services until switching off or the SIM is removed.

If the MS is IMSI attached via MM procedures, the MS shall in addition set the update status to U3 ROAMING NOT ALLOWED, shall delete any TMSI, LAI and ciphering key sequence number. The new MM state is MM IDLE. The SIM shall be considered as invalid also for non-GPRS services until switching off or the SIM is removed.

7 (GPRS services not allowed).

The MS shall set the GPRS update status to GU3 ROAMING NOT ALLOWED (and shall store it according to section 4.1.3.2.9) and shall delete any P-TMSI, P-TMSI signature, RAI and GPRS ciphering key sequence number. The SIM shall be considered as invalid for GPRS services until switching off or the SIM is removed. The new state is GMM-DEREGISTERED.

If the update type is “periodic updating” a GPRS MS operating in MS operation mode A or B in network operation mode I shall set the timer T3212 to its initial value and restart it, if it is not already running.

9 (MS identity cannot be derived by the network).

The MS shall set the GPRS update status to GU2 NOT UPDATED (and shall store it according to section 4.1.3.2), enter the GMM DEREGISTERED, and shall delete any P-TMSI, P-TMSI signature, RAI and GPRS ciphering key sequence number. Subsequently, the MS may automatically initiate the GPRS attach procedure.

10 (Implicitly detached).

The MS shall change to state GMM-DEREGISTERED.NORMAL-SERVICE. The MS shall then perform a new attach procedure. The MS should also activate PDP context(s) to replace any previously active PDP contexts.

NOTE: In some cases, user interaction may be required and then the MS cannot activate the PDP context(s) automatically.

11 (PLMN not allowed);

12 (Location area not allowed); or

13 (Roaming not allowed in this location area).

The MS shall delete any RAI, P-TMSI, P-TMSI signature and GPRS ciphering key sequence number, shall set the GPRS update status to GU3 ROAMING NOT ALLOWED (and shall store it according to section 4.1.3.2) and enter the state GMM-DEREGISTERED.

If the MS is IMSI attached via MM procedures, the MS shall in addition set the update status to U3 ROAMING NOT ALLOWED and shall delete any TMSI, LAI and ciphering key sequence number and shall reset the location update attempt counter. The new MM state is MM IDLE.

The MS shall store the LAI or the PLMN identity in the appropriate forbidden list, i.e. in the “forbidden PLMN list” for cause #11, in the list of “forbidden location areas for regional provision of service” for cause #12 or in the list of “forbidden location areas for roaming” for cause #13. If #11 or #13 was received, the MS shall perform a PLMN selection instead of a cell selection.

14 (GPRS services not allowed in this PLMN)

The MS shall delete any RAI, P-TMSI, P-TMSI signature, and GPRS ciphering key sequence number stored, shall set the GPRS update status to GU3 ROAMING NOT ALLOWED (and shall store it according to section 4.1.3.2) and shall change to state GMM-DEREGISTERED.

The MS shall store the PLMN identity in the "forbidden PLMNs for GPRS service" list. A GPRS MS operating in MS operation mode C shall perform a PLMN selection instead of a cell selection.

If the update type is "periodic updating" a GPRS MS operating in MS operation mode A or B in network operation mode I shall set the timer T3212 to its initial value and restart it, if it is not already running.

A GPRS MS operating in MS operation mode A or B in network operation mode II or III, is still IMSI attached for CS services in the network.

Other values are considered as abnormal cases. The specification of the MS behaviour in those cases is described in section 4.7.5.1.5.

4.7.5.2.3.2 Combined routing area updating successful for GPRS services only

The description for normal routing area update as specified in section 4.7.5.1.3 shall be followed. In addition, the following description for location area updating applies.

The MS receiving the ROUTING AREA UPDATE ACCEPT message takes one of the following actions depending on the reject cause:

#2 (IMSI unknown in HLR).

The MS shall set the update status to U3 ROAMING NOT ALLOWED and shall delete any TMSI, LAI and ciphering key sequence number. The new MM state is MM IDLE. The SIM shall be considered as invalid for non-GPRS services until switching off or the SIM is removed.

#16 (MSC temporarily not reachable);

#17 (Network failure); or

#22 (Congestion).

The MS shall change to state GMM-REGISTERED.ATTEMPTING-TO-UPDATE-MM. Timer T3330 shall be stopped if still running. The routing area updating attempt counter shall be incremented.

If the routing area updating attempt counter is less than 5, and the stored RAI is equal to the RAI of the current serving cell and the GMM update status is equal to GU1 UPDATED:

- the MS shall keep the GMM update status GU1 UPDATED and changes state to GMM-REGISTERED.ATTEMPTING-TO-UPDATE-MM. The MS shall start timer T3311. When timer T3311 expires the combined routing area update procedure indicating “combined RA/LA updating with IMSI attach” is triggered again.

If the routing area updating attempt counter is greater than or equal to 5:

- the MS shall start timer T3302 and shall change to state GMM-REGISTERED.ATTEMPTING-TO-UPDATE-MM;
- a GPRS MS operating in MS operation mode A shall then proceed with appropriate MM specific procedure; a GPRS MS operating in MS operation mode B may then proceed with appropriate MM specific procedures. The MM sublayer shall act as in network operation mode II as long as the combined GMM procedures are not successful and no new RA is entered. The new MM state is MM IDLE.

Other values are considered as abnormal cases. The combined routing area updating shall be considered as failed for GPRS and non-GPRS services. The specification of the MS behaviour in those cases is specified in section 4.7.5.2.5.

4.7.5.2.4 Combined routing area updating not accepted by the network

If the combined routing area updating cannot be accepted, the network sends a ROUTING AREA UPDATE REJECT message to the MS. An MS that receives a ROUTING AREA UPDATE REJECT message stops timer T3330 and enters state MM IDLE. The MS shall then take different actions depending on the received reject cause:

3 (Illegal MS);

6 (Illegal ME); or

8 (GPRS services and non GPRS services not allowed).

The MS shall set the GPRS update status to GU3 ROAMING NOT ALLOWED and the update status to U3 ROAMING NOT ALLOWED (and shall store it according to section 4.1.3.2) and enter the state GMM-DEREGISTERED. Furthermore, it shall delete any P-TMSI, P-TMSI signature, TMSI, RAI, LAI, ciphering key sequence number and GPRS ciphering key sequence number and shall consider the SIM as invalid for GPRS and non GPRS services until switching off or the SIM is removed.

7 (GPRS services not allowed).

The MS shall set the GPRS update status to GU3 ROAMING NOT ALLOWED (and shall store it according to section 4.1.3.2) and shall delete any P-TMSI, P-TMSI signature, RAI and GPRS ciphering key sequence number. The SIM shall be considered as invalid for GPRS services until switching off or the SIM is removed.

The new state is GMM-DEREGISTERED. If in the MS the timer T3212 is not already running, the timer shall be set to its initial value and restarted.

A GPRS MS operating in MS operation mode A or B in network operation mode I, is still IMSI attached for CS services in the network and shall then proceed with the appropriate MM specific procedure according to the MM service state.

9 (MS identity cannot be derived by the network).

The MS shall set the GPRS update status to GU2 NOT UPDATED (and shall store it according to section 4.1.3.2), enter the state GMM-DEREGISTERED, and shall delete any P-TMSI, P-TMSI signature, RAI and GPRS ciphering key sequence number. Subsequently, the MS may automatically initiate the GPRS attach procedure.

A GPRS MS operating in MS operation mode A or B in network operation mode I, is still IMSI attached for CS services in the network.

10 (Implicitly detached)

A GPRS MS operating in MS operation mode A or B in network operation mode I, is IMSI detached for both GPRS and CS services in the network.

The MS shall change to state GMM-DEREGISTERED.NORMAL-SERVICE. The MS shall then perform a new attach procedure. The MS should also activate PDP context(s) to replace any previously active PDP contexts.

NOTE: In some cases, user interaction may be required and then the MS cannot activate the PDP context(s) automatically.

11 (PLMN not allowed);

12 (Location area not allowed); or

13 (Roaming not allowed in this location area)

The MS shall set the GPRS update status to GU3 ROAMING NOT ALLOWED and the update status to U3 ROAMING NOT ALLOWED (and shall store it according to section 4.1.3.2) and enter the state GMM-DEREGISTERED. Furthermore, it shall delete any P-TMSI, P-TMSI signature, TMSI, RAI, LAI, ciphering key sequence number GPRS ciphering key sequence number and reset the location update attempt counter.

The MS shall store the LAI or the PLMN identity in the appropriate forbidden list, i.e. in the “forbidden PLMN list” for cause #11, in the list of “forbidden location areas for regional provision of service” for cause #12 or in the list of “forbidden location areas for roaming” for cause #13. If #11 or #13 was received, the MS shall then perform a PLMN selection instead of a cell selection.

14 (GPRS services not allowed in this PLMN)

The MS shall delete any RAI, P-TMSI, P-TMSI signature, and GPRS ciphering key sequence number stored, shall set the GPRS update status to GU3 ROAMING NOT ALLOWED (and shall store it according to section 4.1.3.2) and shall change to state GMM-DEREGISTERED. If in the MS the timer T3212 is not already running, the timer shall be set to its initial value and restarted.

The MS shall store the PLMN identity in the "forbidden PLMNs for GPRS service" list.

A GPRS MS operating in MS operation mode A or B in network operation mode I, is still IMSI attached for CS services in the network and shall then proceed with the appropriate MM specific procedure according to the MM service state.

Other values are considered as abnormal cases. The specification of the MS behaviour in those cases is described in section 4.7.5.2.5.

10.5.5.14 GMM cause

The purpose of the GMM cause information element is to indicate the reason why a GMM request from the mobile station is rejected by the network.

The GMM cause information element is coded as shown in figure 10.5.129/GSM 04.08 and table 10.5.147/GSM 04.08.

The GMM cause is a type 3 information element with 2 octets length.

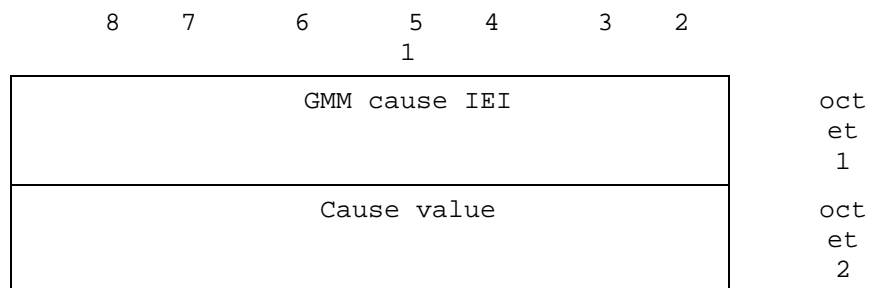

Figure 10.5.129/GSM 04.08: GMM cause information element

Table 10.5.147/GSM 04.08: GMM cause information element

Cause value (octet 2)		
Bits		
8	7 6 5 4 3 2 1	
0 0 0 0 0 0 1 0		IMSI unknown in HLR
0 0 0 0 0 0 1 1		Illegal MS
0 0 0 0 0 1 1 0		Illegal ME
0 0 0 0 0 1 1 1		GPRS services not allowed
0 0 0 0 1 0 0 0		GPRS services and non-GPRS services not allowed
0 0 0 0 1 0 0 1		MS identity cannot be derived by the network
0 0 0 0 1 0 1 0		Implicitly detached
0 0 0 0 1 0 1 1		PLMN not allowed
0 0 0 0 1 1 0 0		Location Area not allowed
0 0 0 0 1 1 0 1		Roaming not allowed in this location area
0 0 0 0 1 1 1 0		GPRS services not allowed in this PLMN
0 0 0 1 0 0 0 0		MSC temporarily not reachable
0 0 0 1 0 0 0 1		Network failure
0 0 0 1 0 1 1 0		Congestion
0 0 1 1 0 0 0 0		} retry upon entry into a new cell
0 0 1 1 1 1 1 1		
0 1 0 1 1 1 1 1		Semantically incorrect message
0 1 1 0 0 0 0 0		Invalid mandatory information
0 1 1 0 0 0 0 1		Message type non-existent or not implemented
0 1 1 0 0 0 1 0		Message type not compatible with the protocol state
0 1 1 0 0 0 1 1		Information element non-existent or not implemented
0 1 1 0 0 1 0 0		Conditional IE error
0 1 1 0 0 1 0 1		Message not compatible with the protocol state
0 1 1 0 1 1 1 1		Protocol error, unspecified

Any other value received by the mobile station shall be treated as 0110 1111, 'Protocol error, unspecified'. Any other value received by the network shall be treated as 0110 1111, 'Protocol error, unspecified'.

NOTE: The listed reject cause values are defined in Annex G.

Annex G (informative): GSM specific cause values for mobility management

This annex is informative. It describes the cause values for the mobility management procedures for non-GPRS services (MM) and GPRS services (GMM). Sections G1 to G5 are valid for both MM and GMM. However, the following codes are applicable for non-GPRS services only:

#38 Call cannot be identified.

Section G.6 applies only for GMM procedures.

G.1 Causes related to MS identification

Cause value = 2 IMSI unknown in HLR.

This cause is sent to the MS if the MS is not known (registered) in the HLR. This cause code does not affect operation of the GPRS service, although it may be used by a GMM procedure.

Cause value = 3 Illegal MS.

This cause is sent to the MS when the network refuses service to the MS either because an identity of the MS is not acceptable to the network or because the MS does not pass the authentication check, i.e. the SRES received from the MS is different from that generated by the network.

Cause value = 4 IMSI unknown in VLR.

This cause is sent to the MS when the given IMSI is not known at the VLR.

Cause value = 5 IMEI not accepted.

This cause is sent to the MS if the network does not accept emergency call establishment using an IMEI.

Cause value = 6 Illegal ME.

This cause is sent to the MS if the ME used is not acceptable to the network, e.g. blacklisted.

G.2 Cause related to subscription options

Cause value = 11 PLMN not allowed.

This cause is sent to the MS if it requests location updating in a PLMN where the MS, by subscription or due to operator determined barring is not allowed to operate.

Cause value = 12 Location Area not allowed.

This cause is sent to the MS if it requests location updating in a location area where the MS, by subscription, is not allowed to operate.

Cause value = 13 Roaming not allowed in this location area.

This cause is sent to an MS which requests location updating in a location area of a PLMN which do not offer roaming to that MS in that Location Area, by subscription.

G.3 Causes related to PLMN specific network failures and congestion

Cause value = 17 Network failure.

This cause is sent to the MS if the MSC cannot service an MS generated request because of PLMN failures, e.g. problems in MAP.

Cause value = 22 Congestion.

This cause is sent if the service request cannot be actioned because of congestion (e.g. no channel, facility busy/congested etc.)

G.4 Causes related to nature of request

Cause value = 32 Service option not supported.

This cause is sent when the MS requests a service/facility in the CM SERVICE REQUEST message which is not supported by the PLMN.

Cause value = 33 Requested service option not subscribed.

This cause is sent when the MS requests a service option for which it has no subscription.

Cause value = 34 Service option temporarily out of order.

This cause is sent when the MSC cannot service the request because of temporary outage of one or more functions required for supporting the service.

Cause value = 38 Call cannot be identified.

This cause is sent when the network cannot identify the call associated with a call re-establishment request.

G.5 Causes related to invalid messages

Cause value = 95 Semantically incorrect message.

See annex H, section H.5.10.

Cause value = 96 Invalid mandatory information.

See annex H, section H.6.1.

Cause value = 97 Message type non-existent or not implemented.

See annex H, section H.6.2.

Cause value = 98 Message not compatible with protocol state.

See annex H, section H.6.3.

Cause value = 99 Information element non-existent or not implemented

See annex H, section H.6.4.

Cause value = 100 Conditional IE error.

See annex H, section H.6.5.

Cause value = 101 Message not compatible with protocol state

See annex H, section H.6.6.

Cause value = 111 Protocol error, unspecified.

See annex H, section H.6.8.

G.6 Additional cause codes for GMM

Cause value = 7 GPRS services not allowed.

This cause is sent to the MS if it requests an IMSI attach for GPRS services, but is not allowed to operate GPRS services.

Cause value = 8 GPRS services and non-GPRS services not allowed.

This cause is sent to the MS if it requests a combined IMSI attach for GPRS and non-GPRS services, but is not allowed to operate either of them.

Cause value = 9 MS identity cannot be derived by the network.

This cause is sent to the MS when the network cannot derive the MS's identity from the P-TMSI in case of inter-SGSN routing area update.

Cause value = 10 Implicitly detached

This cause is sent to the MS either if the network has implicitly detached the MS, e.g. some while after the Mobile reachable timer has expired, or if the GMM context data related to the subscription does not exist in the SGSN e.g. because of a SGSN restart.

Cause value = 16 MSC temporarily not reachable

This cause is sent to the MS if it requests a combined GPRS attach or routing area updating in a PLMN where the MSC is temporarily not reachable via the GPRS part of the GSM network.

Cause value = 14 GPRS services not allowed in this PLMN

This cause is sent to the MS which requests GPRS service in a PLMN which does not offer roaming for GPRS services to that MS.

15-19 January 2001, Beijing, China

CR-Form-v3

CHANGE REQUEST
 ⌘ **03.22** **CR** **A052** ⌘ rev **2** ⌘ Current version: **6.2.0** ⌘

 For **HELP** on using this form, see bottom of this page or look at the pop-up text over the ⌘ symbols.

Proposed change affects: ⌘ (U)SIM ME/UE Radio Access Network Core Network

Title:	⌘ Roaming restrictions for GPRS service		
Source:	⌘ Siemens AG		
Work item code:	⌘ GPRS	Date:	⌘ 2001-01-15
Category:	⌘ F	Release:	⌘ R97
	Use <u>one</u> of the following categories: F (essential correction) A (corresponds to a correction in an earlier release) B (Addition of feature), C (Functional modification of feature) D (Editorial modification) Detailed explanations of the above categories can be found in 3GPP TR 21.900.		Use <u>one</u> of the following releases: 2 (GSM Phase 2) R96 (Release 1996) R97 (Release 1997) R98 (Release 1998) R99 (Release 1999) REL-4 (Release 4) REL-5 (Release 5)

Reason for change:	⌘ Experience from the deployment of GPRS in live networks brought out that some existing roaming scenarios and configurations does not work. In the case when operator has only roaming agreement for CS services but not for PS service (GPRS) there is no suitable cause value with which PS attach can be rejected without impact on both the GSM roaming and the GPRS services in other networks. More detail description of the problem can be found from TSG CN Plenary #14 Tdoc NP-000697 and TSG SA Plenary #10 Tdoc SP-000666.
Summary of change:	⌘ In order to solve the problem it is proposed to introduce a new rejection cause value "GPRS services not allowed in this PLMN" (#14) that could be indicated to the MS during GPRS attach, detach and RAU in a PLMN which does not offer GPRS roaming to that MS. When MS receives this cause code it shall not attempt new GPRS attach before entering a new PLMN on which it hasn't be rejected with the same cause after the last switch on. In order to memorise the PLMNs on which the MS is already rejected with #14, a new PLMN list is introduced, which should be deleted when the MS is switched off. The list is introduced in order to avoid subsequent registration attempts which could occur if either the MS(in class C mode), or the user(in class A/B mode) triggers a PLMN reselection after reception of #14.
Consequences if not approved:	⌘ If no roaming agreement is established for GPRS or the SGSN has no knowledge about the HLR of the roaming subscriber, depending on the SGSN implementation either #11 or #7 will probably send to the MS which disables in minimum the PS until the MS is switched off. The only other possibility would be that the network sends a cause code not listed explicitly, with the consequence that the MS will try to register "forever" (5 re-attempts after each T3302 expiry) which causes a considerable network load and results in a unacceptable behaviour from the users point of view(long term no service and battery

consumption)

Clauses affected: ⌘ 3.1; 3.7; 4.3.4; 4.4.3.1; 4.5; 4.6.2

Other specs affected: ⌘ Other core specifications ⌘
 Test specifications
 O&M Specifications

Other comments: ⌘

1.1 References

The following documents contain provisions which, through reference in this text, constitute provisions of the present document.

- References are either specific (identified by date of publication, edition number, version number, etc.) or non-specific.
- For a specific reference, subsequent revisions do not apply.
- For a non-specific reference, the latest version applies.
- A non-specific reference to an ETS shall also be taken to refer to later versions published as an EN with the same number.
- For this Release 1998 document, references to GSM documents are for Release 1998 versions (version 7.x.y).

- [1] GSM 01.04: "Digital cellular telecommunications system (Phase 2+); Abbreviations and acronyms".
- [2] GSM 02.01: "Digital cellular telecommunications system (Phase 2+); Principles of telecommunications services supported by a GSM Public Land Mobile Network (PLMN)".
- [3] GSM 02.02: "Digital cellular telecommunication system (Phase 2+); Bearer Services (BS) supported by a GSM Public Land Mobile Network (PLMN)".
- [4] GSM 02.03: "Digital cellular telecommunications system (Phase 2+); Teleservices supported by a GSM Public Land Mobile Network (PLMN)".
- [5] GSM 02.04: "Digital cellular telecommunications system (Phase 2+); General on supplementary services".
- [6] GSM 02.06: "Digital cellular telecommunications system (Phase 2+); Types of Mobile Stations (MS)".
- [7] GSM 02.07: "Digital cellular telecommunications system (Phase 2+); Mobile Station (MS) features".
- [8] GSM 02.09: "Digital cellular telecommunications system (Phase 2+); Security aspects".
- [9] GSM 02.11: "Digital cellular telecommunications system (Phase 2+); Service accessibility".
- [10] GSM 02.16: "Digital cellular telecommunications system (Phase 2+); International Mobile station Equipment Identities (IMEI)".
- [11] GSM 02.17: "Digital cellular telecommunications system (Phase 2+); Subscriber identity modules Functional characteristics".
- [12] GSM 02.24: "Digital cellular telecommunications system (Phase 2+); Description of Charge Advice Information (CAI)".
- [13] GSM 02.30: "Digital cellular telecommunications system (Phase 2+); Man-Machine Interface (MMI) of the Mobile Station (MS)".
- [14] GSM 02.40: "Digital cellular telecommunications system (Phase 2+); Procedures for call progress indications".
- [15] GSM 02.41: "Digital cellular telecommunications system (Phase 2+); Operator determined barring".
- [16] GSM 02.81: "Digital cellular telecommunications system (Phase 2+); Line identification supplementary services - Stage 1".
- [17] GSM 02.82: "Digital cellular telecommunications system (Phase 2+); Call Forwarding (CF) supplementary services - Stage 1".

- [18] GSM 02.83: "Digital cellular telecommunications system (Phase 2+); Call Waiting (CW) and Call Hold (HOLD) supplementary services - Stage 1".
- [19] GSM 02.84: "Digital cellular telecommunications system (Phase 2+); MultiParty (MPTY) supplementary services - Stage 1".
- [20] GSM 02.85: "Digital cellular telecommunications system (Phase 2+); Closed User Group (CUG) supplementary services - Stage 1".
- [21] GSM 02.86: "Digital cellular telecommunications system (Phase 2+); Advice of Charge (AoC) supplementary services - Stage 1".
- [22] GSM 02.88: "Digital cellular telecommunications system (Phase 2+); Call Barring (CB) supplementary services - Stage 1".
- [23] GSM 04.08: "Digital cellular telecommunications system (Phase 2+); Mobile radio interface layer 3 specification".
- [24] GSM 05.02: "Digital cellular telecommunications system (Phase 2+); Multiplexing and multiple access on the radio path".
- [25] GSM 05.08: "Digital cellular telecommunications system (Phase 2+); Radio subsystem link control".
- [26] GSM 02.60: "Digital cellular telecommunications system (Phase 2+); General Packet Radio Service (GPRS); Service description Stage 1".
- [27] GSM 03.60: "Digital cellular telecommunications system (Phase 2+); General Packet Radio Service (GPRS); Service description Stage 2".
- [28] GSM 03.64: "Digital cellular telecommunications system (Phase 2+); General Packet Radio Service (GPRS); Overall description of the GPRS Radio Interface; Stage 2".
- [29] GSM 02.56: "Digital cellular telecommunications system (Phase 2+); GSM Cordless Telephony System (CTS); Service Description; Stage 1
- [30] GSM 03.56: "Digital cellular telecommunications system (Phase 2+); GSM Cordless Telephony System (CTS); CTS Architecture Description; Stage 2

1.2 Definitions and abbreviations

Abbreviations used in the present document are listed in GSM 01.04.

Home PLMN	This is a PLMN where the MCC and MNC of the PLMN identity match the MCC and MNC of the IMSI. Matching criteria are defined in Annex A.
Selected PLMN	This is the PLMN that has been selected according to subclause 3.1, either manually or automatically.
Available PLMN	This is a PLMN where the MS has found a cell that satisfies conditions (ii) and (iv) of subclause 3.2.1.
Registered PLMN (RPLMN)	This is the PLMN on which certain LR outcomes have occurred (see table 1).
Allowable PLMN	<u>In the case of a MS operating in MS operation mode A or B, this is a PLMN which is not in the list of forbidden PLMNs in the MS.</u> <u>In the case of a MS operating in MS operation mode C, this is a PLMN which is not in the list of forbidden PLMNs or in the list of "forbidden PLMNs for GPRS service" in the MS</u>
Visited PLMN of home country	This is a PLMN, different from the home PLMN, where the MCC part of the PLMN identity is the same as the MCC of the IMSI.
Registration	This is the process of camping on a cell of the PLMN and doing any necessary LRs.
Camped on a cell	The MS (ME if there is no SIM) has completed the cell selection/reselection process and has chosen a cell from which it plans to receive all available services. Note that the services may be limited, and that the PLMN may not be aware of the existence of the MS (ME) within the chosen cell.
Current serving cell	This is the cell on which the MS is camped.
Suitable Cell	This is a cell on which an MS may camp. It must satisfy criteria (i) to (v) of subclause 3.2.1. For an MS in group receive mode, the suitable cell is determined by the criteria defined in subclause 5.2.3.
Acceptable Cell	This is a cell that the MS may camp on to make emergency calls. It must satisfy criteria (ii) and (iv) of subclause 3.2.1.
Group call	A communication in which several MSs can receive, but at most one may be allowed to transmit on a radio channel. Examples of group calls are those established for the voice group call service (VGCS, see GSM 03.68).
Broadcast call	A communication in which several MSs can receive, but only the originator of the call is allowed to transmit on the radio channel. Examples of the broadcast call are those established for the voice broadcast service (VBS, see GSM 03.69).
Group receive mode	State of the MS when it is engaged in a group or broadcast call as a listener.
GPRS MS	An MS capable of GPRS services is a GPRS MS.
MS operation mode	See GSM 03.60[27]
CTS MS	An MS capable of CTS services is a CTS MS.
Location Registration (LR)	An MS which is IMSI attached to non-GPRS services only performs location registration by the Location Updating procedure. A GPRS MS which is IMSI attached to GPRS services or to GPRS and non-GPRS services performs location registration by the Routing Area Update procedure only when in a network of network operation mode I. Both procedures are performed independently by the GPRS MS when it is IMSI attached to GPRS and non-GPRS services in a network of network operation mode II or III (see GSM 03.60).
Localised Service Area (LSA)	A localised service area consists of a cell or a number of cells. The cells constituting a LSA may not necessarily provide contiguous coverage.
SoLSA exclusive access	Cells on which normal camping is allowed only for MS with Localised Service Area (LSA) subscription.

Registration Area

A registration area is an area in which mobile stations may roam without a need to perform location registration. The registration area corresponds to location area (LA) for performing location updating procedure and it corresponds to routing area for performing the routing area update procedure.

The PLMN to which a cell belongs (PLMN identity) is given in the system information transmitted on the BCCH (MCC + MNC part of LAI).

3.1 PLMN selection and roaming

The MS normally operates on its home PLMN (HPLMN). However a visited PLMN (VPLMN) may be selected, e.g., if the MS loses coverage. There are two modes for PLMN selection:

- i) Automatic mode - This mode utilizes a list of PLMNs in priority order. The highest priority PLMN which is available and allowable is selected.
- ii) Manual mode - Here the MS indicates to the user which PLMNs are available. Only when the user makes a manual selection does the MS try to obtain normal service on the VPLMN.

There are two cases:

- International Roaming - This is where the MS receives service on a PLMN of a different country than that of the HPLMN.
- National Roaming - This is where the MS receives service from a PLMN of the same country as that of the HPLMN, either anywhere or on a regional basis. The MS makes a periodic search for the HPLMN while national roaming.

To prevent repeated attempts to have roaming service on a not allowed LA, when the MS is informed that an LA is forbidden, the LA is added to a list of "forbidden LAs for roaming" which is stored in the MS. This list is deleted when the MS is switched off or when the SIM is removed. Such area restrictions are always valid for complete location areas independent of possible subdivision into GPRS routing areas. The structure of the routing area identifier (GSM 03.03) supports area restriction on LA basis.

If a "PLMN not allowed" message is received by an MS in response to an LR request from a VPLMN, that VPLMN is added to a list of "forbidden PLMNs" in the SIM and thereafter that VPLMN will not be accessed by the MS when in automatic mode. A PLMN is removed from the "forbidden" list if, after a subsequent manual selection of that PLMN, there is a successful LR. This list is retained when the MS is switched off or the SIM is removed. The HPLMN shall not be stored on the list of "forbidden PLMNs".

Optionally the ME may store in its memory an extension of the forbidden PLMN list. The contents of the extension of the list shall be deleted when the MS is switched off or the SIM is removed.

If a "GPRS services not allowed in this PLMN" message is received by an MS in response to an GPRS attach, GPRS detach or routing area update request from a VPLMN, that VPLMN is added to a list of "forbidden PLMNs for GPRS service" which is stored in the MS and thereafter that VPLMN will not be accessed by the MS for GPRS service when in automatic mode. This list is deleted when the MS is switched off or when the SIM is removed. A PLMN is removed from the list of "forbidden PLMNs for GPRS service" if, after a subsequent manual selection of that PLMN, there is a successful GPRS attach. The maximum number of possible entries in this list is implementation dependant, but must be at least one entry. The HPLMN shall not be stored on the list of "forbidden PLMNs for GPRS service".

3.3 Regional provision of service

An MS may have a "regionally restricted service" where it can only obtain service on certain LAs. If such an MS attempts to camp on a cell of an LA for which it does not have service entitlement, when it does an LR request, it will receive an "LA not allowed" message. In this case:

- The MS stores the forbidden LA identity (LAI) in a list of "forbidden LAIs for regional provision of service", to prevent repeated access attempts on a cell of the forbidden LA. This list is deleted when the MS is switched off or the SIM is removed. If the MS cannot find a suitable cell, the MS performs the PLMN selection procedure starting at subclause 4.4.3.1 A or B.

3.4 Borders between registration areas

If the MS is moving in a border area between registration areas, it might repeatedly change between cells of different registration areas. Each change of registration area would require an LR, which would cause a heavy signalling load and increase the risk of a paging message being lost. To prevent this, a "CELL_RESELECT_HYSTERESIS" (CRH) parameter is used. A cell in a different registration area is only selected if it is "better", in terms of the path loss criterion (see subclause 3.6), than all the cells in the current registration area by at least the value of CRH. The CRH parameter is broadcast as system information. As the value of CRH broadcast may be different on different cells, the CRH parameter to be used is that broadcast on the current serving cell. There is also a lower limit on the time interval between reselection of cells on different registration areas. Instead of CRH a GPRS MS uses a "GPRS_CELL_RESELECT_HYSTERESIS" if provided.

3.5 Barred cells and access control

3.5.1 Barred cells

The PLMN operator may decide not to allow MSs to camp on certain cells. (These cells may, for example, only be used for hand over traffic, i.e. calls which need to be handed over to other cells). Barred cell information is broadcast as system information to instruct MSs not to camp on these cells. The barred cell status may in fact change dynamically; hence the MS needs to regularly check the system information for this parameter.

The barred status of a cell depends both on CELL_BAR_ACCESS and on the cell's priority indicated by CELL_BAR_QUALIFY. The effect of these two parameters is further described in GSM 05.08.

If a cell is barred this applies both for cell selection and reselection.

3.5.2 Prioritizing cells

In general, cell prioritization is a means of encouraging MSs to select some suitable cells in preference to others. Since the priority comparison is only between suitable cells, prioritization does not affect coverage. Operators may prefer a certain type of cell not to be selected unless it is the only suitable type. For example, umbrella cells due to their large frequency reuse distance, or microcells because the MS could be travelling too fast for them.

3.5.2.1 For cell selection

During cell selection (see subclause 3.2.1), a cell with low priority indication will only be selected if a suitable cell of normal priority cannot be found.

3.5.2.2 For cell reselection

Cell prioritization can also be achieved during cell reselection by the use of the reselection parameters optionally broadcast. Cells are reselected on the basis of a parameter called C2 and the C2 value for each cell is given a positive or negative offset to encourage or discourage MSs to reselect that cell. A full range of positive and negative offsets is provided to allow the incorporation of this feature into already operational networks. Instead of C2 a GPRS MS uses the GPRS cell reselection parameter if provided.

3.5.3 Access control

Due to problems in certain areas, Network Operators may decide to restrict access from some MSs (e.g., in case of congestion on the AGCH), and for this reason the access control mechanism is provided.

At subscription one or more access control classes are allocated to the subscriber and stored in the SIM. The information providing all authorized classes is broadcast as system information (together with a bit indicating whether emergency calls may be made). This information is modified dynamically and therefore the MS has to check the system information before each attempt to access.

The MS ignores the Access Control information when selecting a cell to camp on, i.e. it shall not reject a cell for camping on because access on that cell is not allowed.

3.5.4 Forbidden LA for regional provision of service

When the MS is camped on a cell, the LA of which belongs to the list of forbidden LA for regional provision of service, the MS is not allowed to initiate establishment of a CM connection except for an emergency call; it may respond to paging. Also, the MS is not allowed to request GPRS services when camped on a cell of a LA of which belongs to the list of forbidden LA.

If the MS has received the cause "LA not allowed", it shall ignore this fact when selecting a cell to camp on, i.e. it shall not reject a cell for camping on because that cell is part of a LA where this cause has been received.

3.7 No suitable cell (limited service state)

There are a number of situations in which the MS is unable to obtain normal service from a PLMN. These include:

- a) Failure to find a suitable cell of the selected PLMN;
- b) No SIM in the MS;
- c) A "PLMN not allowed" response to an LR;
- d) An "illegal MS", "illegal ME" or "IMSI unknown in HLR" response to an LR; (Any SIM in the ME is then considered "invalid".)
- e) A "GPRS not allowed" response to an LR of a GPRS MS operating in MS operation mode ~~Attached to GPRS services only~~. (The cell selection state of GPRS MSs attached to GPRS and non-GPRS depends on the outcome of the location updating.);
- f) A "GPRS services not allowed in this PLMN" response to an LR of a GPRS MS operating in MS operation mode C.

(In automatic PLMN selection mode, events (a), (c) and (e) would normally cause a new PLMN selection, but even here, the situation may arise when no PLMNs are available and allowable for use).

Under any of these conditions, the MS attempts to camp on an acceptable cell, irrespective of its PLMN identity, so that emergency calls can be made if necessary. When in the limited service state with a valid SIM, the MS shall search for available and allowable PLMNs in the manner described in subclause 4.4.3.1. To minimize the time taken to find new available PLMNs while maintaining battery life, discontinuous search schemes may be used, see GSM 02.11. No LR requests are made until a valid SIM is present and either a suitable cell is found or a manual network reselection is performed. In the limited service state the presence of the MS need not be known to the PLMN on whose cell it has camped. Cell reselection takes place as normal, except that a zero dB value of CRH will be used.

There are also other conditions under which only emergency calls may be made. These are shown in table 2.

4.2 States description

Each of the processes of PLMN selection, cell selection and location registration can be described by a set of states. The overall state of the mobile is thus a composite of the states of the three processes. In some cases, an event which causes a change of state in one process may trigger a change of state in another process, e.g., camping on a cell in a new registration area triggers an LR request. The relationship between the processes is illustrated in figure 1.

The states in which the MS may be, for each of the processes, are described below and illustrated in figures 2 to 4. For many of the states, a fuller description can be found in other GSM Technical Specifications, and a reference to the GSM Technical Specification and the relevant section within it, are given after the state description.

In the event of any conflict between the diagrams and the text in the present document, the text takes precedence.

4.3 List of states

4.3.1 List of states for the PLMN selection process

4.3.1.1 List of states for automatic mode (figure 2a)

- A1 Trying RPLMN - The MS is trying to perform a Location Registration on the registered PLMN.
- A2 On PLMN - The MS has successfully registered on a PLMN.
- A3 Trying PLMN - The MS is trying to register on a PLMN in the ordered list of PLMNs.
- A4 Wait for PLMNs to appear - There are no allowable and available PLMNs at present and the MS is waiting for one to appear.
- A5 HPLMN search in progress - The MS is trying to find if the HPLMN is available.
- A6 No SIM - There is no SIM in the MS, or certain LR responses have been received.

4.3.1.2 List of states for manual mode (figure 2b)

- M1 Trying registered PLMN - The MS is trying to perform a Location Registration on the registered PLMN.
- M2 On PLMN - The MS has successfully registered on a PLMN.
- M3 Not on PLMN - The MS has failed to register on the selected PLMN.
- M4 Trying PLMN - The MS is trying to register on a user selected PLMN.
- M5 No SIM - There is no SIM in the MS, or certain LR responses have been received.

4.3.2 List of States for the cell selection process (figure 3)

- C1 Normal Cell Selection - This is the process of initial cell selection, searching all GSM or DCS RF channels.
- C2 Stored List Cell Selection - This is the process of initial cell selection where BCCH carrier information (e.g. a BA list) for the selected PLMN is stored in the MS.
- C3 Camped Normally - This is where the MS is camped on a cell of the selected PLMN and may be able to make and receive calls. (Whether or not the MS can make and receive calls depends on the state within the location registration process). The MS monitors received level and the system information and checks whether cell reselection is needed.
- C4 Normal Cell Reselection - This is where the MS has determined that cell reselection is needed and an attempt is being made to reselect a new cell.

- C5 Choose Cell - This is where the MS has returned to idle mode from "connected mode" and is choosing a suitable cell to camp on.
- C6 Any Cell Selection - This is where the MS is unable to camp normally on any cell of the selected PLMN, or cannot obtain service because of certain responses to a location registration (LR) attempt. It is searching for a cell of any PLMN to camp on (so that emergency calls can be made).
- C7 Camped on any Cell - This is where the MS has camped on a cell irrespective of its PLMN identity, so that emergency calls can be made.
- C8 Any Cell Reselection - This is where the MS is attempting to reselect a cell, irrespective of PLMN identity.
- C9 Choose Any Cell - This is where the MS is returning to idle mode, after having entered "connected mode" from the "camped on any cell" state to make an emergency call. It is attempting to find an acceptable cell to camp on.

For detailed description of the behaviour in the above states see GSM 05.08.

4.3.3 List of states for location updating (figure 4)

The states are entered depending on responses to location update (LU) requests.

4.3.4 List of states for location registration (figure 4)

The states are entered depending on responses to location registration (LR) requests. Independent update states exist for GPRS and for non-GPRS operation in MSs capable of GPRS and non-GPRS services.

- L1 Updated - The MS enters this state if an LR request is accepted. The update status is set to "updated". The GPRS and the non-GPRS update state of a MS may enter "updated" as a result of combined signalling or as a result of individual signalling depending on the capabilities of the network.
- L2 Idle, No IMSI - The MS enters this state if an LR request is rejected with cause:
- a) IMSI unknown in HLR;
 - b) illegal ME;
 - c) illegal MS;
 - d) GPRS not allowed;
- or if there is no SIM. All update states of a MS enter this state regardless whether received by individual or combined signalling for events b) and c). Event a) results in "Roaming not allowed" for the non-GPRS update state only. Event a) has no influence on the GPRS update state. Event d) results in "Roaming not allowed" for the GPRS update state only. Event d) has no influence on the non-GPRS update state.
- If a SIM is present, the non-GPRS update status of the SIM is set to "Roaming not allowed" for events a), b) and c).
- L3 Roaming not allowed - The MS enters this state if it receives an LU reject message with the cause:
- a) PLMN not allowed;
 - b) Location area not allowed;
 - c) Roaming not allowed in this location area.
 - d) GPRS services not allowed in this PLMN

~~Exept from event d) a~~All update states of the MS are set to "Roaming not allowed" regardless whether received by individual or combined signalling. Event d) results in "Roaming not allowed" for the GPRS update state only. Event d) has no influence on the non-GPRS update state. The behaviour of the MS in the roaming not allowed state is dependent on the LR reject cause as shown in table 2. Additionally:

- in automatic mode, "PLMN not allowed" and "roaming not allowed in this location area" cause the Automatic Network Selection procedure of subclause 4.4.3.1A to be started; it is also caused by ~~"GPRS not allowed"~~ "GPRS services not allowed in this PLMN" when received by a GPRS MS operating in MS operation mode Ceapable of GPRS only;
- in manual mode, "PLMN not allowed" and "roaming not allowed in this location area" cause the Manual Network Selection procedure of subclause 4.4.3.1B to be started; it is also caused by ~~"GPRS not allowed"~~ "GPRS services not allowed in this PLMN" when received by a GPRS MS operating in MS operation mode Ceapable of GPRS only.

L4

Not updated - The MS enters this state if any LR failure not specified for states L2 or L3 occurs, in which cases the MS is not certain whether or not the network has received and accepted the LR attempt. The non-GPRS update status on the SIM and/or the GPRS update status are set to "not updated" depending on the specific location registration procedure and their outcome.

4.4.3 PLMN selection

The registration on the selected PLMN and the location registration are only necessary if the MS is capable of services which require registration. Otherwise, the PLMN selection procedures are performed without registration.

4.4.3.1 At switch-on or recovery from lack of coverage

At switch on, the MS selects and attempts to perform a Location Registration on the registered PLMN, if it exists. On recovery from lack of coverage, the MS selects the registered PLMN (if it exists) and, if necessary (see subclause 4.6.2) attempts to perform a Location Registration.

If successful registration is achieved, the MS indicates the selected PLMN.

If there is no registered PLMN, or if registration is not possible due to the PLMN being unavailable or registration failure, the MS follows one of the following two procedures depending on its operating mode.

EXCEPTION: If registration is not possible on recovery from lack of coverage due to the registered PLMN being unavailable, a MS attached to GPRS services may, optionally, continue looking for the registered PLMN for an implementation dependent time.

NOTE: A MS attached to GPRS services should use the above exception only if one or more PDP contexts are currently active.

A) Automatic Network Selection Mode Procedure

The MS selects and attempts registration on other PLMNs, if available and allowable, in all of its bands of operation in the following order:

- i) HPLMN (if not previously selected);
- ii) each PLMN in the "PLMN Selector" data field in the SIM (in priority order);
- iii) other PLMNs with received signal level above -85 dBm in random order;
- iv) all other PLMNs in order of decreasing signal strength.

If successful registration is achieved, the MS indicates the selected PLMN.

If registration cannot be achieved because no PLMNs are available and allowable, the MS indicates "no service" to the user, waits until a new PLMN is available and allowable and then repeats the procedure.

If there were one or more PLMNs which were available and allowable, but an LR failure made registration on those PLMNs unsuccessful or an entry in a forbidden LAI list prevented a registration attempt, the MS selects the first such PLMN again and enters a limited service state.

B) Manual Network Selection Mode Procedure

The MS indicates whether there are any PLMNs, in all of its bands of operation, which are available. This includes "Forbidden PLMNs". Any PLMN shall only be presented once.

If displayed, PLMNs meeting the criteria above are presented in the following order:

- i) HPLMN;
- ii) PLMNs contained in the "PLMN Selector" data field in the SIM (in priority order);
- iii) other PLMNs with received signal level above -85 dBm in random order;
- iv) all other PLMNs in order of decreasing signal strength.

The user may select his desired PLMN and the MS then initiates registration on this PLMN. (This may take place at any time during the presentation of PLMNs). For such a registration, the MS shall ignore the contents of the forbidden LAI lists, "forbidden PLMNs for GPRS service" lists and forbidden PLMN lists.

If the user does not select a PLMN, the selected PLMN shall be the one that was selected before the PLMN selection procedure started. If no such PLMN was selected or that PLMN is no longer available, then the MS shall attempt to camp on any acceptable cell and enter the limited service state

4.5 Cell selection process

Whenever a PLMN is selected, the MS attempts to find a suitable cell of that PLMN to camp on. Two methods of searching for a suitable cell are possible:

- a) Normal cell selection ("Normal cell selection" state) - Here the MS has no prior knowledge of which RF channels are BCCH carriers. It searches at least the number, given in subclause 3.2.1, of the strongest RF channels in descending order of received signal level to see which are BCCH carriers. (If no BCCH carriers have yet been found, searching will continue until at least one BCCH carrier is found.). The first BCCH carrier found which is from a suitable cell and on which there is a normal priority indication is taken and that cell is camped on. If at least the number, given in subclause 3.2.1, of the strongest RF channels have been tried and the only suitable cells found have low priority indication the MS shall camp on the strongest of these cells.
- b) Stored list cell selection (optional) ("Stored list cell selection" state)- Here the MS has a list of the BCCH carriers used by the PLMN. (This list may be derived by the MS from information gathered during previous selections of the PLMN). The BCCH carriers in the list are searched in descending order of received signal level, and the first BCCH carrier found which is from a suitable cell and on which there is a normal priority indication is taken, and that cell is camped on. If an MS decodes BCCH data from a cell of the selected PLMN but is unable to camp on that cell, the BA of that cell shall be examined and any BCCH carriers in the BA which are not in the list of BCCH carriers to be searched shall be added to the list. If all these BCCH carriers have been tried and the only suitable cells found have low priority indication, the MS shall camp on the strongest of these cells.

If no suitable cell is found using method b), method a) is then tried.

While camped on a cell of the selected PLMN ("camped normally"), the MS may need to select a different cell ("normal cell reselection" state). The following events trigger a cell reselection:

- i) The path loss criterion parameter C1 (see subclause 3.6) indicates that the path loss to the cell has become too high;
- ii) There is a downlink signalling failure (subclause 3.6);
- iii) The cell camped on (current serving cell) has become barred;
- iv) There is a better cell (in terms of the path loss criterion C2) in the same registration area, or a much better cell in another registration area of the selected PLMN (using the CRH parameter, subclause 3.4);
- v) A random access attempt is still unsuccessful after "Max retrans" repetitions; "Max retrans" being a parameter broadcast on control channel.

A GPRS MS in Ready state applies the READY_STATE CELL RESELECTION HYSTERESIS together with the path loss criterion when reselecting the cell within the registration area. The GPRS MS in Ready state shall inform the network about cell reselection within the registration area by the cell update procedure. The network may control cell reselection of a GPRS MS in Ready state (GSM 03.64).

Instead of the parameter C2, a GPRS MS applies the corresponding GPRS parameter if provided. If this GPRS parameter is provided the cell shall also broadcast a list BA(GPRS) indicating BCCH carriers to be monitored by GPRS MSs for cell re-selection purpose.

The MS will then reselect a new cell in order to fulfil the process goal (see subclause 4.1).

Before camping on the cell after re-selection, the MS shall attempt to decode the full set of system information. The MS shall check that the parameters affecting cell re-selection are unchanged. If a change is detected the MS shall check if the cell re-selection criterion is still valid using the changed parameters. If the cell selection criteria are still valid, the MS shall camp on the cell. If they are not still valid, the MS shall repeat this process for the cell with the next highest value of C2 or corresponding GPRS parameter, respectively.

Once the MS has re-tuned to the chosen cell, it shall monitor its paging subgroup (if known) for that cell. If the MS and the cell support group or broadcast calls, it shall also monitor the notification channel. A GPRS MS shall monitor the relevant GPRS control channel(s). If the MS receives a page before having decoded the relevant system information for the new cell, the MS shall store the page and respond, if permitted, once the relevant system information has been decoded. If not permitted, no page response shall be made.

When the MS leaves idle mode and enters "connected mode" (e.g., to make a call), on return to idle mode at the end of the call, a cell must be chosen ("choose cell" state) as soon as possible e.g., to allow a new call to be made as soon as possible. The chosen cell will not necessarily be the same cell as the MS was camped on when the call started e.g., if the MS moved a significant distance while the call was in progress. Two cases are distinguished in GSM 05.08, for which the algorithm is slightly different:

- a) Normal case - The call is terminated, either because the user (or network) has terminated the call, or because a radio link failure has occurred and call re-establishment is not being attempted.
- b) Call re-establishment - A radio link failure has occurred and a call re-establishment is being attempted. (The MS returns to idle mode to start the call re-establishment attempt and needs to select a new cell on which to make the attempt as soon as possible in order to minimize the interruption to the call).

If no suitable cell is found by either the stored list cell selection, normal cell reselection, or choose cell tasks (all of which use a limited search), the normal cell selection task (which searches all RF channels for a suitable cell) is entered.

If no suitable cell is found by the normal cell selection task, or if there is no SIM in the MS, the MS attempts to find an "acceptable cell" on which it may camp so that emergency calls may be made ("any cell selection" state). The MS ignores the PLMN information when selecting an acceptable cell, and no attempt at location registration is made. This task is also entered if an LR reject is received with one of the following cause values:

- "IMSI unknown in HLR" (only for non-GPRS MS as this impacts only the non-GPRS update state, MSs capable of GPRS and non-GPRS services take a cell selection state according to the outcome of the routing area update);
- "Illegal MS";
- "illegal ME";
- "PLMN not allowed" (However, this will trigger a new PLMN selection if the MS is in automatic mode);
- ~~"GPRS not allowed"~~ "GPRS services not allowed in this PLMN" (only for GPRS MS operating in MS operation mode C ~~capable of GPRS only~~, where this will trigger a new PLMN selection if the MS is in automatic mode; a GPRS MSs operating in MS operation mode A or B ~~capable of GPRS and non-GPRS services~~ take a cell selection state according to the outcome of location updating as ~~"GPRS not allowed"~~ "GPRS services not allowed in this PLMN" has only impact on the GPRS update status).

If an acceptable cell is found, the MS camps on it ("Camped on any cell" state). If one of the cell reselection trigger events (i) to (v) above occurs, the MS attempts to find a new acceptable cell to camp on ("any cell reselection" state) but using a zero dB value of CRH. If no acceptable cell can be found, the "any cell selection" task is re-entered.

If while camped on an acceptable cell, an emergency call origination is made, the MS enters a connected mode and at the end of the call, chooses an acceptable cell ("choose any cell" state) so that it is ready for the next emergency call origination.

In all cases, if a new PLMN is selected, the MS searches for a suitable cell of that PLMN. However, if the MS has recently searched the strongest RF channels while a previous PLMN was selected, it may already have information about other PLMNs.

The user may request a search of RF channels to determine which PLMNs are available. This search shall be done in such a way as to minimize interruptions to the MS's monitoring of its paging subchannel.

4.6 Location registration process

4.6.1 General

When the MS is switched on and capable of services requiring registration, the action taken by the location registration process is as follows:

- a) SIM present and no LR needed (because of the status of the stored registration area identity and "attach" flag):
The MS is in the update state UPDATED;
- b) SIM present and LR needed: A LR request is made;
- c) No SIM present: The MS enters the update state Idle, NO IMSI.

In case b) above, and subsequently whenever a LR request is made, the MS enters a state depending on the outcome of the LR request, as listed in subclause 4.3.3 above. In case c) the GPRS and the non-GPRS update state enters "IDLE, NO IMSI".

Whenever the MS goes to connected mode and then returns to idle mode again, the MS selects the appropriate state.

4.6.2 Initiation of Location Registration

An LR request indicating Normal Updating is made when, in idle mode,

- the MS changes cell while being in the update state NOT UPDATED; (for MS capable of GPRS and non-GPRS services when at least one of both update states is NOT UPDATED)
- the MS detects that it has entered a new registration area, i.e., when the received registration area identity differs from the one stored in the MS, and the LAI or the PLMN identity is not contained in a list of forbidden LAIs, "forbidden PLMNs for GPRS service" or forbidden PLMN identities respectively, while being in one of the following update states:
 - UPDATED;
 - NOT UPDATED;
 - ROAMING NOT ALLOWED.
- the Periodic Location Updating Timer expires while being in the non-GPRS update state NOT UPDATED (triggers Location Updating);
- the Periodic Routing Area Update timer expires while being in the GPRS update state NOT UPDATED (triggers Routing Area Update);
- a manual network reselection has been performed, an acceptable cell of the selected PLMN is present, and the MS is not in the UPDATED state on the selected PLMN.

An LR request indicating Periodic Location Updating is made when, in idle mode, the Periodic Location Updating timer expires while being in the non-GPRS update state UPDATED.

An LR request indicating Periodic Routing Area Update is made when the Periodic Routing Area Update timer expires while being in the GPRS update state UPDATED.

An LR request indicating IMSI attach is made when the MS is activated in the same location area in which it was deactivated while being in the non-GPRS update state UPDATED, and the system information indicates that IMSI attach/detach shall be used.

A GPRS attach is made by a GPRS MS when activated and capable of services which require registration. A GPRS attach may only performed if the selected PLMN is not contained in the list of "forbidden PLMNs for GPRS service". Depending on system information about GPRS network operation mode MSs operating in MS operation mode A or Beapable of GPRS and non-GPRS services perform combined or non-combined location registration procedures. When the combined routing area update or GPRS attach is accepted with indication "MSC not reachable" or is not answered the MS performs also the corresponding location updating procedure or falls back to a GPRS only MS. When the combined routing area update or GPRS attach is rejected with cause "GPRS not allowed" the GPRS update state is

"IDLE, NO IMSI" and the MS performs the corresponding location updating procedure ~~or falls back to a GPRS only MS.~~

Furthermore, an LR request indicating Normal Location Updating is also made when the response to an outgoing request shows that the MS is unknown in the VLR or SGSN, respectively.

Table 2 summarizes the events in each state that trigger a new LR request. The actions that may be taken while being in the various states are also outlined in table 2.

A GPRS MS which is both IMSI attached for GPRS and non-GPRS services and which is capable of simultaneous operation of GPRS and non-GPRS services shall perform Routing Area Update in connected mode when it has entered a new routing area which is not part of a LA contained in the list of forbidden LAIs.

4.6.4 IMSI attach/detach operation

The system information will contain an indicator indicating whether or not IMSI attach/detach operation is mandatory to use in the cell. The MS shall operate in accordance with the received value of the indicator.

A GPRS MS shall perform GPRS attach/detach procedures independent of the value of the IMSI attach/detach indicator. When a GPRS MS has to perform IMSI attach/detach independent of GPRS procedures (for example GPRS network operation mode 2) the handling described in the paragraph above applies.

When IMSI attach/detach operation applies, a MS shall send the IMSI detach message to the network when the MS is powered down or the SIM is removed while being in the update state UPDATED. The IMSI detach message will not be acknowledged by the network.

When the MS returns to the active state, the MS shall perform an LR request indicating IMSI attach, provided that the MS still is in the same registration area. If the registration area has changed, an LR request indicating Normal Location Updating according to subclause 4.6.2 shall be performed.

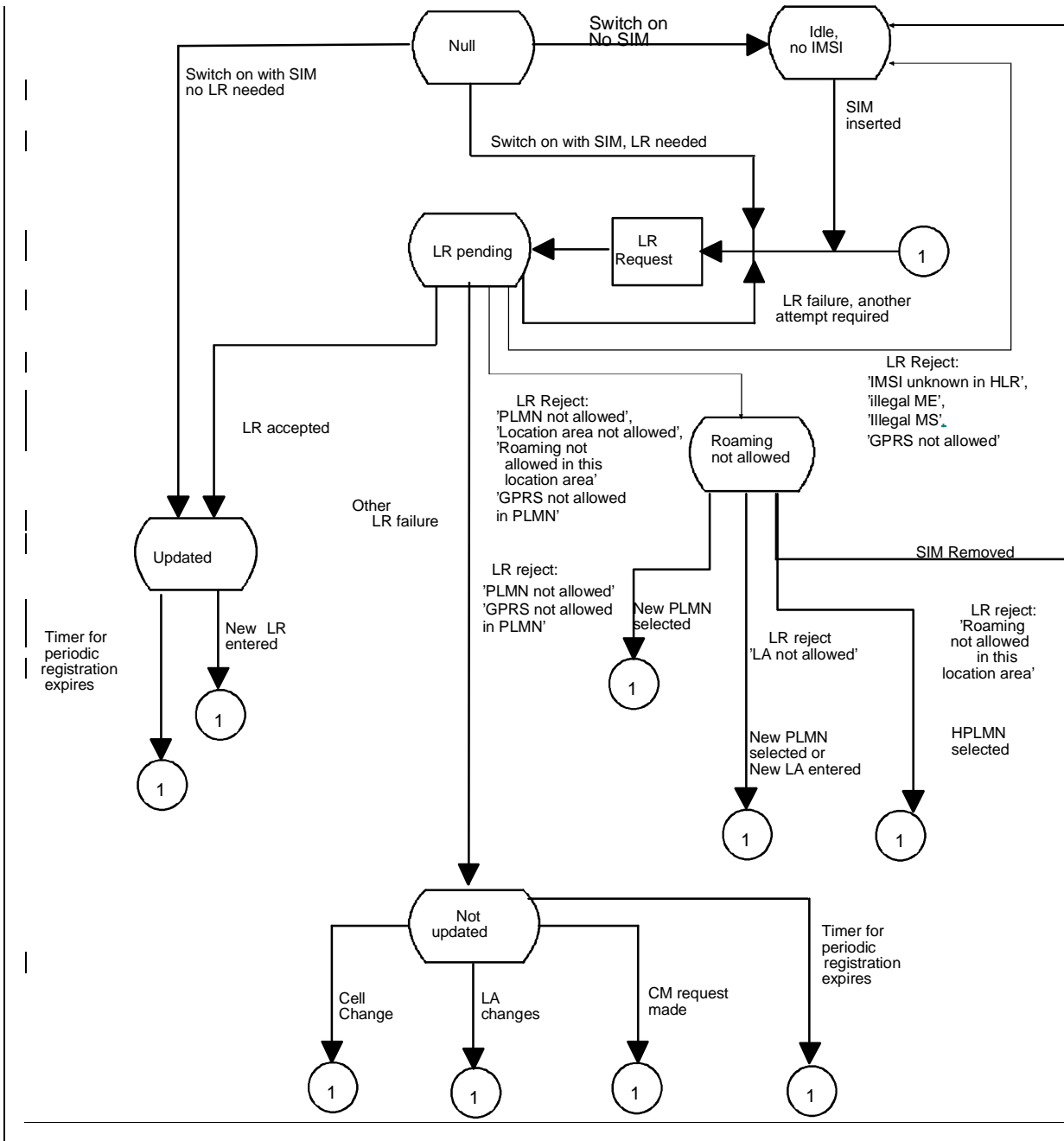

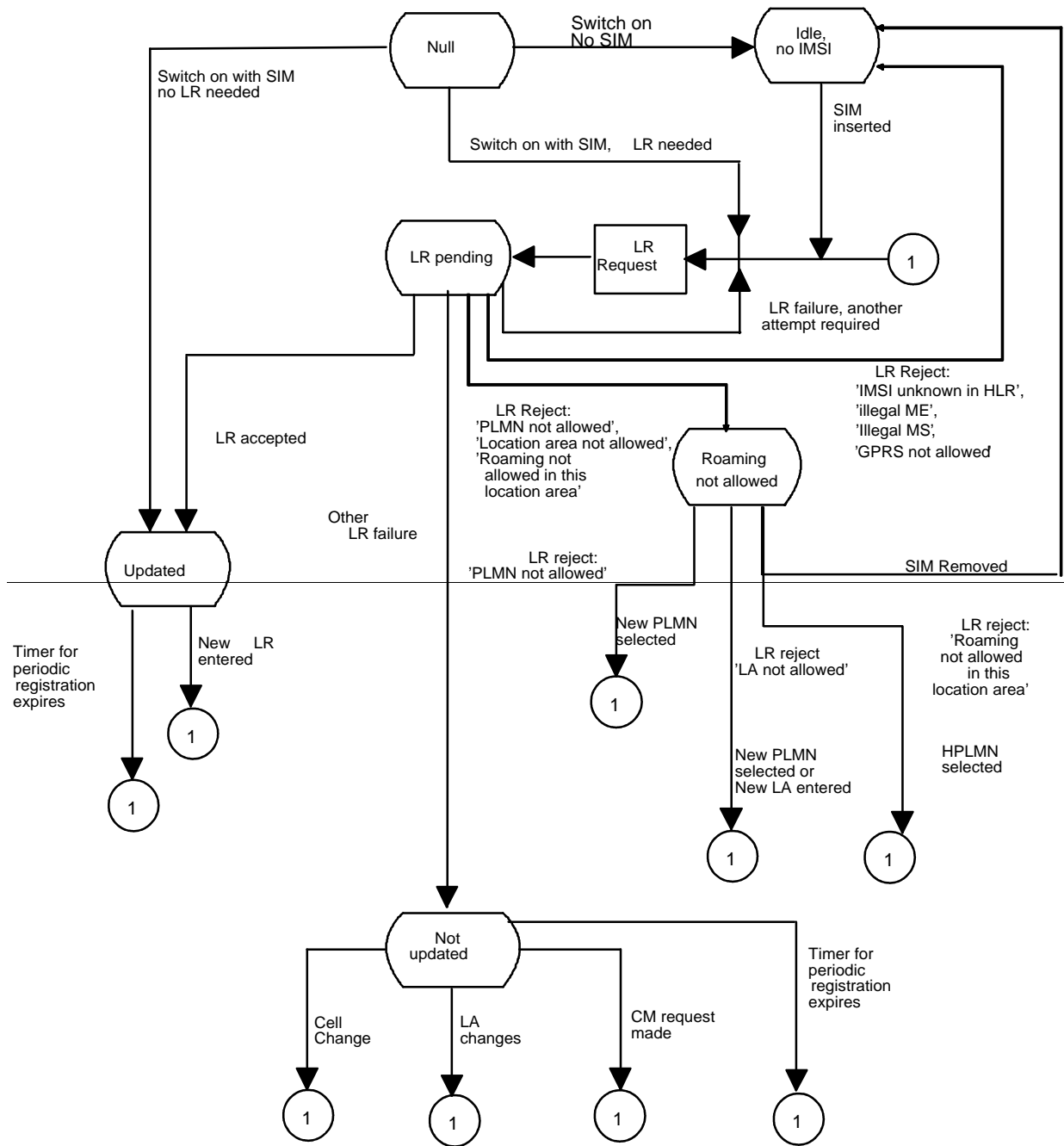

NOTE: Whenever the MS goes to connected mode and then returns to idle mode again the MS selects appropriate state.
 A MS capable of GPRS and non-GPRS services has two Task State machines one for GPRS and one for non-GPRS operation.

Figure 4: Location Registration Task State diagram

15-19 January 2001, Beijing, China

CR-Form-v3

CHANGE REQUEST
 ⌘ **03.22** **CR** **A053** ⌘ rev **1** ⌘ Current version: **7.3.0** ⌘

 For **HELP** on using this form, see bottom of this page or look at the pop-up text over the ⌘ symbols.

Proposed change affects: ⌘ (U)SIM ME/UE Radio Access Network Core Network

Title:	⌘ Roaming restrictions for GPRS service		
Source:	⌘ Siemens AG		
Work item code:	⌘ GPRS	Date:	⌘ 2001-01-15
Category:	⌘ A	Release:	⌘ R98
	Use <u>one</u> of the following categories: F (essential correction) A (corresponds to a correction in an earlier release) B (Addition of feature), C (Functional modification of feature) D (Editorial modification) Detailed explanations of the above categories can be found in 3GPP TR 21.900.		Use <u>one</u> of the following releases: 2 (GSM Phase 2) R96 (Release 1996) R97 (Release 1997) R98 (Release 1998) R99 (Release 1999) REL-4 (Release 4) REL-5 (Release 5)

Reason for change:	⌘ Experience from the deployment of GPRS in live networks brought out that some existing roaming scenarios and configurations does not work. In the case when operator has only roaming agreement for CS services but not for PS service (GPRS) there is no suitable cause value with which PS attach can be rejected without impact on both the GSM roaming and the GPRS services in other networks. More detail description of the problem can be found from TSG CN Plenary #14 Tdoc NP-000697 and TSG SA Plenary #10 Tdoc SP-000666.
Summary of change:	⌘ In order to solve the problem it is proposed to introduce a new rejection cause value "GPRS services not allowed in this PLMN" (#14) that could be indicated to the MS during GPRS attach, detach and RAU in a PLMN which does not offer GPRS roaming to that MS. When MS receives this cause code it shall not attempt new GPRS attach before entering a new PLMN on which it hasn't be rejected with the same cause after the last switch on. In order to memorise the PLMNs on which the MS is already rejected with #14, a new PLMN list is introduced, which should be deleted when the MS is switched off. The list is introduced in order to avoid subsequent registration attempts which could occur if either the MS(in class C mode), or the user(in class A/B mode) triggers a PLMN reselection after reception of #14.
Consequences if not approved:	⌘ If no roaming agreement is established for GPRS or the SGSN has no knowledge about the HLR of the roaming subscriber, depending on the SGSN implementation either #11 or #7 will probably send to the MS which disables in minimum the PS until the MS is switched off. The only other possibility would be that the network sends a cause code not listed explicitly, with the consequence that the MS will try to register "forever" (5 re-attempts after each T3302 expiry) which causes a considerable network load and results in a unacceptable behaviour from the users point of view(long term no service and battery

consumption)

Clauses affected: ⌘ 3.1; 3.7; 4.3.4; 4.4.3.1; 4.5; 4.6.2

Other specs affected: ⌘ Other core specifications ⌘
 Test specifications
 O&M Specifications

Other comments: ⌘

1.1 References

The following documents contain provisions which, through reference in this text, constitute provisions of the present document.

- References are either specific (identified by date of publication, edition number, version number, etc.) or non-specific.
- For a specific reference, subsequent revisions do not apply.
- For a non-specific reference, the latest version applies.
- A non-specific reference to an ETS shall also be taken to refer to later versions published as an EN with the same number.
- For this Release 1998 document, references to GSM documents are for Release 1998 versions (version 7.x.y).

- [1] GSM 01.04: "Digital cellular telecommunications system (Phase 2+); Abbreviations and acronyms".
- [2] GSM 02.01: "Digital cellular telecommunications system (Phase 2+); Principles of telecommunications services supported by a GSM Public Land Mobile Network (PLMN)".
- [3] GSM 02.02: "Digital cellular telecommunication system (Phase 2+); Bearer Services (BS) supported by a GSM Public Land Mobile Network (PLMN)".
- [4] GSM 02.03: "Digital cellular telecommunications system (Phase 2+); Teleservices supported by a GSM Public Land Mobile Network (PLMN)".
- [5] GSM 02.04: "Digital cellular telecommunications system (Phase 2+); General on supplementary services".
- [6] GSM 02.06: "Digital cellular telecommunications system (Phase 2+); Types of Mobile Stations (MS)".
- [7] GSM 02.07: "Digital cellular telecommunications system (Phase 2+); Mobile Station (MS) features".
- [8] GSM 02.09: "Digital cellular telecommunications system (Phase 2+); Security aspects".
- [9] GSM 02.11: "Digital cellular telecommunications system (Phase 2+); Service accessibility".
- [10] GSM 02.16: "Digital cellular telecommunications system (Phase 2+); International Mobile station Equipment Identities (IMEI)".
- [11] GSM 02.17: "Digital cellular telecommunications system (Phase 2+); Subscriber identity modules Functional characteristics".
- [12] GSM 02.24: "Digital cellular telecommunications system (Phase 2+); Description of Charge Advice Information (CAI)".
- [13] GSM 02.30: "Digital cellular telecommunications system (Phase 2+); Man-Machine Interface (MMI) of the Mobile Station (MS)".
- [14] GSM 02.40: "Digital cellular telecommunications system (Phase 2+); Procedures for call progress indications".
- [15] GSM 02.41: "Digital cellular telecommunications system (Phase 2+); Operator determined barring".
- [16] GSM 02.81: "Digital cellular telecommunications system (Phase 2+); Line identification supplementary services - Stage 1".
- [17] GSM 02.82: "Digital cellular telecommunications system (Phase 2+); Call Forwarding (CF) supplementary services - Stage 1".

- [18] GSM 02.83: "Digital cellular telecommunications system (Phase 2+); Call Waiting (CW) and Call Hold (HOLD) supplementary services - Stage 1".
- [19] GSM 02.84: "Digital cellular telecommunications system (Phase 2+); MultiParty (MPTY) supplementary services - Stage 1".
- [20] GSM 02.85: "Digital cellular telecommunications system (Phase 2+); Closed User Group (CUG) supplementary services - Stage 1".
- [21] GSM 02.86: "Digital cellular telecommunications system (Phase 2+); Advice of Charge (AoC) supplementary services - Stage 1".
- [22] GSM 02.88: "Digital cellular telecommunications system (Phase 2+); Call Barring (CB) supplementary services - Stage 1".
- [23] GSM 04.08: "Digital cellular telecommunications system (Phase 2+); Mobile radio interface layer 3 specification".
- [24] GSM 05.02: "Digital cellular telecommunications system (Phase 2+); Multiplexing and multiple access on the radio path".
- [25] GSM 05.08: "Digital cellular telecommunications system (Phase 2+); Radio subsystem link control".
- [26] GSM 02.60: "Digital cellular telecommunications system (Phase 2+); General Packet Radio Service (GPRS); Service description Stage 1".
- [27] GSM 03.60: "Digital cellular telecommunications system (Phase 2+); General Packet Radio Service (GPRS); Service description Stage 2".
- [28] GSM 03.64: "Digital cellular telecommunications system (Phase 2+); General Packet Radio Service (GPRS); Overall description of the GPRS Radio Interface; Stage 2".
- [29] GSM 02.56: "Digital cellular telecommunications system (Phase 2+); GSM Cordless Telephony System (CTS); Service Description; Stage 1
- [30] GSM 03.56: "Digital cellular telecommunications system (Phase 2+); GSM Cordless Telephony System (CTS); CTS Architecture Description; Stage 2

1.2 Definitions and abbreviations

Abbreviations used in the present document are listed in GSM 01.04.

Home PLMN	This is a PLMN where the MCC and MNC of the PLMN identity match the MCC and MNC of the IMSI. Matching criteria are defined in Annex A.
Selected PLMN	This is the PLMN that has been selected according to subclause 3.1, either manually or automatically.
Available PLMN	<u>In the case of a MS operating in MS operation mode A or B, this is a PLMN where the MS has found a cell that satisfies conditions (ii) and (iv) of subclause 3.2.1.</u> <u>In the case of a MS operating in MS operation mode C, this is a PLMN which is not in the list of forbidden PLMNs or in the list of "forbidden PLMNs for GPRS service" in the MS</u>
Registered PLMN (RPLMN)	This is the PLMN on which certain LR outcomes have occurred (see table 1).
Allowable PLMN	This is a PLMN which is not in the list of forbidden PLMNs in the MS.
Visited PLMN of home country	This is a PLMN, different from the home PLMN, where the MCC part of the PLMN identity is the same as the MCC of the IMSI.
Registration	This is the process of camping on a cell of the PLMN and doing any necessary LRs.
Camped on a cell	The MS (ME if there is no SIM) has completed the cell selection/reselection process and has chosen a cell from which it plans to receive all available services. Note that the services may be limited, and that the PLMN may not be aware of the existence of the MS (ME) within the chosen cell.
Current serving cell	This is the cell on which the MS is camped.
Suitable Cell	This is a cell on which an MS may camp. It must satisfy criteria (i) to (v) of subclause 3.2.1. For an MS in group receive mode, the suitable cell is determined by the criteria defined in subclause 5.2.3.
Acceptable Cell	This is a cell that the MS may camp on to make emergency calls. It must satisfy criteria (ii) and (iv) of subclause 3.2.1.
Group call	A communication in which several MSs can receive, but at most one may be allowed to transmit on a radio channel. Examples of group calls are those established for the voice group call service (VGCS, see GSM 03.68).
Broadcast call	A communication in which several MSs can receive, but only the originator of the call is allowed to transmit on the radio channel. Examples of the broadcast call are those established for the voice broadcast service (VBS, see GSM 03.69).
Group receive mode	State of the MS when it is engaged in a group or broadcast call as a listener.
GPRS MS	An MS capable of GPRS services is a GPRS MS.
MS operation mode	See GSM 03.60[27].
CTS MS	An MS capable of CTS services is a CTS MS.
Location Registration (LR)	An MS which is IMSI attached to non-GPRS services only performs location registration by the Location Updating procedure. A GPRS MS which is IMSI attached to GPRS services or to GPRS and non-GPRS services performs location registration by the Routing Area Update procedure only when in a network of network operation mode I. Both procedures are performed independently by the GPRS MS when it is IMSI attached to GPRS and non-GPRS services in a network of network operation mode II or III (see GSM 03.60).
Localised Service Area (LSA)	A localised service area consists of a cell or a number of cells. The cells constituting a LSA may not necessarily provide contiguous coverage.
SoLSA exclusive access	Cells on which normal camping is allowed only for MS with Localised Service Area (LSA) subscription.

Registration Area

A registration area is an area in which mobile stations may roam without a need to perform location registration. The registration area corresponds to location area (LA) for performing location updating procedure and it corresponds to routing area for performing the routing area update procedure.

The PLMN to which a cell belongs (PLMN identity) is given in the system information transmitted on the BCCH (MCC + MNC part of LAI).

3.1 PLMN selection and roaming

The MS normally operates on its home PLMN (HPLMN). However a visited PLMN (VPLMN) may be selected, e.g., if the MS loses coverage. There are two modes for PLMN selection:

- i) Automatic mode - This mode utilizes a list of PLMNs in priority order. The highest priority PLMN which is available and allowable is selected.
- ii) Manual mode - Here the MS indicates to the user which PLMNs are available. Only when the user makes a manual selection does the MS try to obtain normal service on the VPLMN.

There are two cases:

- International Roaming - This is where the MS receives service on a PLMN of a different country than that of the HPLMN.
- National Roaming - This is where the MS receives service from a PLMN of the same country as that of the HPLMN, either anywhere or on a regional basis. The MS makes a periodic search for the HPLMN while national roaming.

To prevent repeated attempts to have roaming service on a not allowed LA, when the MS is informed that an LA is forbidden, the LA is added to a list of "forbidden LAs for roaming" which is stored in the MS. This list is deleted when the MS is switched off or when the SIM is removed. Such area restrictions are always valid for complete location areas independent of possible subdivision into GPRS routing areas. The structure of the routing area identifier (GSM 03.03) supports area restriction on LA basis.

If a "PLMN not allowed" message is received by an MS in response to an LR request from a VPLMN, that VPLMN is added to a list of "forbidden PLMNs" in the SIM and thereafter that VPLMN will not be accessed by the MS when in automatic mode. A PLMN is removed from the "forbidden" list if, after a subsequent manual selection of that PLMN, there is a successful LR. This list is retained when the MS is switched off or the SIM is removed. The HPLMN shall not be stored on the list of "forbidden PLMNs".

A ME not supporting SoLSA may consider a cell with the escape PLMN code (see GSM 03.73) to be a part of a PLMN belonging to the list of "forbidden PLMNs".

Optionally the ME may store in its memory an extension of the forbidden PLMN list. The contents of the extension of the list shall be deleted when the MS is switched off or the SIM is removed.

If a "GPRS services not allowed in this PLMN" message is received by an MS in response to an GPRS attach, GPRS detach or routing area update request from a VPLMN, that VPLMN is added to a list of "forbidden PLMNs for GPRS service" which is stored in the MS and thereafter that VPLMN will not be accessed by the MS for GPRS service when in automatic mode. This list is deleted when the MS is switched off or when the SIM is removed. A PLMN is removed from the list of "forbidden PLMNs for GPRS service" if, after a subsequent manual selection of that PLMN, there is a successful GPRS attach. The maximum number of possible entries in this list is implementation dependant, but must be at least one entry. The HPLMN shall not be stored on the list of "forbidden PLMNs for GPRS service".

3.7 No suitable cell (limited service state)

There are a number of situations in which the MS is unable to obtain normal service from a PLMN. These include:

- a) Failure to find a suitable cell of the selected PLMN;
- b) No SIM in the MS;
- c) A "PLMN not allowed" response to an LR;
- d) An "illegal MS", "illegal ME" or "IMSI unknown in HLR" response to an LR; (Any SIM in the ME is then considered "invalid".)
- e) A "GPRS not allowed" response to an LR of a GPRS MS operating in MS operation mode ~~Attached to GPRS services only~~. (The cell selection state of GPRS MSs attached to GPRS and non-GPRS depends on the outcome of the location updating.)
- f) A "GPRS services not allowed in this PLMN" response to an LR of a GPRS MS operating in MS operation mode C.

(In automatic PLMN selection mode, events (a), (c) and (e) would normally cause a new PLMN selection, but even here, the situation may arise when no PLMNs are available and allowable for use).

Under any of these conditions, the MS attempts to camp on an acceptable cell, irrespective of its PLMN identity, so that emergency calls can be made if necessary. When in the limited service state with a valid SIM, the MS shall search for available and allowable PLMNs in the manner described in subclause 4.4.3.1. To minimize the time taken to find new available PLMNs while maintaining battery life, discontinuous search schemes may be used, see GSM 02.11. No LR requests are made until a valid SIM is present and either a suitable cell is found or a manual network reselection is performed. In the limited service state the presence of the MS need not be known to the PLMN on whose cell it has camped. Cell reselection takes place as normal, except that a zero dB value of CRH will be used.

There are also other conditions under which only emergency calls may be made. These are shown in table 2.

4.3.4 List of states for location registration (figure 4)

The states are entered depending on responses to location registration (LR) requests. Independent update states exist for GPRS and for non-GPRS operation in MSs capable of GPRS and non-GPRS services.

- L1 Updated - The MS enters this state if an LR request is accepted. The update status is set to "updated". The GPRS and the non-GPRS update state of a MS may enter "updated" as a result of combined signalling or as a result of individual signalling depending on the capabilities of the network.
- L2 Idle, No IMSI - The MS enters this state if an LR request is rejected with cause:
- a) IMSI unknown in HLR;
 - b) illegal ME;
 - c) illegal MS;
 - d) GPRS not allowed;
- or if there is no SIM. All update states of a MS enter this state regardless whether received by individual or combined signalling for events b) and c). Event a) results in "Roaming not allowed" for the non-GPRS update state only. Event a) has no influence on the GPRS update state. Event d) results in "Roaming not allowed" for the GPRS update state only. Event d) has no influence on the non-GPRS update state.
- If a SIM is present, the non-GPRS update status of the SIM is set to "Roaming not allowed" for events a), b) and c).
- L3 Roaming not allowed - The MS enters this state if it receives an LU reject message with the cause:
- a) PLMN not allowed;
 - b) Location area not allowed;
 - c) Roaming not allowed in this location area.
 - d) GPRS services not allowed in this PLMN
-
- Exept from event d) aAll update states of the MS are set to "Roaming not allowed" regardless whether received by individual or combined signalling. Event d) results in "Roaming not allowed" for the GPRS update state only. Event d) has no influence on the non-GPRS update state. The behaviour of the MS in the roaming not allowed state is dependent on the LR reject cause as shown in table 2. Additionally:
- in automatic mode, "PLMN not allowed" and "roaming not allowed in this location area" cause the Automatic Network Selection procedure of subclause 4.4.3.1A to be started; it is also caused by ~~"GPRS not allowed"~~"GPRS services not allowed in this PLMN" when received by a GPRS MS operating in MS operation mode Ceapable of GPRS only;
 - in manual mode, "PLMN not allowed" and "roaming not allowed in this location area" cause the Manual Network Selection procedure of subclause 4.4.3.1B to be started; it is also caused by ~~"GPRS not allowed"~~"GPRS services not allowed in this PLMN" when received by a GPRS MS operating in MS operation mode Ceapable of GPRS only.
- L4 Not updated - The MS enters this state if any LR failure not specified for states L2 or L3 occurs, in which cases the MS is not certain whether or not the network has received and accepted the LR attempt. The non-GPRS update status on the SIM and/or the GPRS update status are set to "not updated" depending on the specific location registration procedure and their outcome.

4.4.3 PLMN selection

The registration on the selected PLMN and the location registration are only necessary if the MS is capable of services which require registration. Otherwise, the PLMN selection procedures are performed without registration.

4.4.3.1 At switch-on or recovery from lack of coverage

At switch on, the MS selects and attempts to perform a Location Registration on the registered PLMN, if it exists. On recovery from lack of coverage, the MS selects the registered PLMN (if it exists) and, if necessary (see subclause 4.6.2) attempts to perform a Location Registration.

If successful registration is achieved, the MS indicates the selected PLMN.

If there is no registered PLMN, or if registration is not possible due to the PLMN being unavailable or registration failure, the MS follows one of the following two procedures depending on its operating mode.

EXCEPTION: If registration is not possible on recovery from lack of coverage due to the registered PLMN being unavailable, a MS attached to GPRS services may, optionally, continue looking for the registered PLMN for an implementation dependent time.

NOTE: A MS attached to GPRS services should use the above exception only if one or more PDP contexts are currently active.

A) Automatic Network Selection Mode Procedure

The MS selects and attempts registration on other PLMNs, if available and allowable, in all of its bands of operation in the following order:

- i) HPLMN (if not previously selected);
- ii) each PLMN in the "PLMN Selector" data field in the SIM (in priority order);
- iii) other PLMNs with received signal level above -85 dBm in random order;
- iv) all other PLMNs in order of decreasing signal strength.

If successful registration is achieved, the MS indicates the selected PLMN.

If registration cannot be achieved because no PLMNs are available and allowable, the MS indicates "no service" to the user, waits until a new PLMN is available and allowable and then repeats the procedure.

If there were one or more PLMNs which were available and allowable, but an LR failure made registration on those PLMNs unsuccessful or an entry in a forbidden LAI list prevented a registration attempt, the MS selects the first such PLMN again and enters a limited service state.

B) Manual Network Selection Mode Procedure

The MS indicates whether there are any PLMNs, in all of its bands of operation, which are available. This includes "Forbidden PLMNs". Any PLMN shall only be presented once.

If displayed, PLMNs meeting the criteria above are presented in the following order:

- i) HPLMN;
- ii) PLMNs contained in the "PLMN Selector" data field in the SIM (in priority order);
- iii) other PLMNs with received signal level above -85 dBm in random order;
- iv) all other PLMNs in order of decreasing signal strength.

The user may select his desired PLMN and the MS then initiates registration on this PLMN. (This may take place at any time during the presentation of PLMNs). For such a registration, the MS shall ignore the contents of the forbidden LAI lists, "forbidden PLMNs for GPRS service" lists and forbidden PLMN lists.

If the user does not select a PLMN, the selected PLMN shall be the one that was selected before the PLMN selection procedure started. If no such PLMN was selected or that PLMN is no longer available, then the MS shall attempt to camp on any acceptable cell and enter the limited service state.

4.5 Cell selection process

Whenever a PLMN is selected, the MS attempts to find a suitable cell of that PLMN to camp on. Two methods of searching for a suitable cell are possible:

- a) Normal cell selection ("Normal cell selection" state) - Here the MS has no prior knowledge of which RF channels are BCCH carriers. It searches at least the number, given in subclause 3.2.1, of the strongest RF channels in descending order of received signal level to see which are BCCH carriers. (If no BCCH carriers have yet been found, searching will continue until at least one BCCH carrier is found.). The first BCCH carrier found which is from a suitable cell and on which there is a normal priority indication is taken and that cell is camped on. If at least the number, given in subclause 3.2.1, of the strongest RF channels have been tried and the only suitable cells found have low priority indication the MS shall camp on the strongest of these cells.
- b) Stored list cell selection (optional) ("Stored list cell selection" state) - Here the MS has a list of the BCCH carriers used by the PLMN. (This list may be derived by the MS from information gathered during previous selections of the PLMN). The BCCH carriers in the list are searched in descending order of received signal level, and the first BCCH carrier found which is from a suitable cell and on which there is a normal priority indication is taken, and that cell is camped on. If an MS decodes BCCH data from a cell of the selected PLMN but is unable to camp on that cell, the BA of that cell shall be examined and any BCCH carriers in the BA which are not in the list of BCCH carriers to be searched shall be added to the list. If all these BCCH carriers have been tried and the only suitable cells found have low priority indication, the MS shall camp on the strongest of these cells.

If no suitable cell is found using method b), method a) is then tried.

While camped on a cell of the selected PLMN ("camped normally"), the MS may need to select a different cell ("normal cell reselection" state). The following events trigger a cell reselection:

- i) The path loss criterion parameter C1 (see subclause 3.6) indicates that the path loss to the cell has become too high;
- ii) There is a downlink signalling failure (subclause 3.6);
- iii) The cell camped on (current serving cell) has become barred;
- iv) There is a better cell (in terms of the path loss criterion C2) in the same registration area, or a much better cell in another registration area of the selected PLMN (using the CRH parameter, subclause 3.4);
- v) A random access attempt is still unsuccessful after "Max retrans" repetitions; "Max retrans" being a parameter broadcast on control channel.

A GPRS MS in Ready state applies the READY_STATE CELL RESELECTION HYSTERESIS together with the path loss criterion when reselecting the cell within the registration area. The GPRS MS in Ready state shall inform the network about cell reselection within the registration area by the cell update procedure. The network may control cell reselection of a GPRS MS in Ready state (GSM 03.64).

Instead of the parameter C2, a GPRS MS applies the corresponding GPRS parameter if provided. If this GPRS parameter is provided the cell shall also broadcast a list BA(GPRS) indicating BCCH carriers to be monitored by GPRS MSs for cell re-selection purpose.

An MS supporting SoLSA with SoLSA subscription shall use the SoLSA cell re-selection parameters.

The MS will then reselect a new cell in order to fulfil the process goal (see subclause 4.1).

Before camping on the cell after re-selection, the MS shall attempt to decode the full set of system information. The MS shall check that the parameters affecting cell re-selection are unchanged. If a change is detected the MS shall check if the cell re-selection criterion is still valid using the changed parameters. If the cell selection criteria are still valid, the MS shall camp on the cell. If they are not still valid, the MS shall repeat this process for the cell with the next highest value of C2 or corresponding GPRS parameter or SoLSA parameters, respectively.

Once the MS has re-tuned to the chosen cell, it shall monitor its paging subgroup (if known) for that cell. If the MS and the cell support group or broadcast calls, it shall also monitor the notification channel. A GPRS MS shall monitor the relevant GPRS control channel(s). If the MS receives a page before having decoded the relevant system information for the new cell, the MS shall store the page and respond, if permitted, once the relevant system information has been decoded. If not permitted, no page response shall be made.

When the MS leaves idle mode and enters "connected mode" (e.g., to make a call), on return to idle mode at the end of the call, a cell must be chosen ("choose cell" state) as soon as possible e.g., to allow a new call to be made as soon as possible. The chosen cell will not necessarily be the same cell as the MS was camped on when the call started e.g., if the MS moved a significant distance while the call was in progress. Two cases are distinguished in GSM 05.08, for which the algorithm is slightly different:

- a) Normal case - The call is terminated, either because the user (or network) has terminated the call, or because a radio link failure has occurred and call re-establishment is not being attempted.
- b) Call re-establishment - A radio link failure has occurred and a call re-establishment is being attempted. (The MS returns to idle mode to start the call re-establishment attempt and needs to select a new cell on which to make the attempt as soon as possible in order to minimize the interruption to the call).

If no suitable cell is found by either the stored list cell selection, normal cell reselection, or choose cell tasks (all of which use a limited search), the normal cell selection task (which searches all RF channels for a suitable cell) is entered.

If no suitable cell is found by the normal cell selection task, or if there is no SIM in the MS, the MS attempts to find an "acceptable cell" on which it may camp so that emergency calls may be made ("any cell selection" state). The MS ignores the PLMN information when selecting an acceptable cell, and no attempt at location registration is made. This task is also entered if an LR reject is received with one of the following cause values:

- "IMSI unknown in HLR" (only for non-GPRS MS as this impacts only the non-GPRS update state, MSs capable of GPRS and non-GPRS services take a cell selection state according to the outcome of the routing area update);
- "Illegal MS";
- "illegal ME";
- "PLMN not allowed" (However, this will trigger a new PLMN selection if the MS is in automatic mode);
- "GPRS not allowed"/"GPRS services not allowed in this PLMN" (only for GPRS MS operating in MS operation mode C capable of GPRS only, where this will trigger a new PLMN selection if the MS is in automatic mode; a GPRS MSs operating in MS operation mode A or B capable of GPRS and non-GPRS services take a cell selection state according to the outcome of location updating as "GPRS not allowed"/"GPRS services not allowed in this PLMN" has only impact on the GPRS update status).

If an acceptable cell is found, the MS camps on it ("Camped on any cell" state). If one of the cell reselection trigger events (i) to (v) above occurs, the MS attempts to find a new acceptable cell to camp on ("any cell reselection" state) but using a zero dB value of CRH. If no acceptable cell can be found, the "any cell selection" task is re-entered.

If while camped on an acceptable cell, an emergency call origination is made, the MS enters a connected mode and at the end of the call, chooses an acceptable cell ("choose any cell" state) so that it is ready for the next emergency call origination.

In all cases, if a new PLMN is selected, the MS searches for a suitable cell of that PLMN. However, if the MS has recently searched the strongest RF channels while a previous PLMN was selected, it may already have information about other PLMNs.

The user may request a search of RF channels to determine which PLMNs are available. This search shall be done in such a way as to minimize interruptions to the MS's monitoring of its paging subchannel.

4.6 Location registration process

4.6.1 General

When the MS is switched on and capable of services requiring registration, the action taken by the location registration process is as follows:

- a) SIM present and no LR needed (because of the status of the stored registration area identity and "attach" flag):
The MS is in the update state UPDATED;
- b) SIM present and LR needed: A LR request is made;
- c) No SIM present: The MS enters the update state Idle, NO IMSI.

In case b) above, and subsequently whenever a LR request is made, the MS enters a state depending on the outcome of the LR request, as listed in subclause 4.3.3 above. In case c) the GPRS and the non-GPRS update state enters "IDLE, NO IMSI".

Whenever the MS goes to connected mode and then returns to idle mode again, the MS selects the appropriate state.

4.6.2 Initiation of Location Registration

An LR request indicating Normal Updating is made when, in idle mode,

- the MS changes cell while being in the update state NOT UPDATED; (for MS capable of GPRS and non-GPRS services when at least one of both update states is NOT UPDATED)
- the MS detects that it has entered a new registration area, i.e., when the received registration area identity differs from the one stored in the MS, and the LAI or the PLMN identity is not contained in a list of forbidden LAIs, "forbidden PLMNs for GPRS service" or forbidden PLMN identities respectively, while being in one of the following update states:
 - UPDATED;
 - NOT UPDATED;
 - ROAMING NOT ALLOWED.
- the Periodic Location Updating Timer expires while being in the non-GPRS update state NOT UPDATED (triggers Location Updating);
- the Periodic Routing Area Update timer expires while being in the GPRS update state NOT UPDATED (triggers Routing Area Update);
- a manual network reselection has been performed, an acceptable cell of the selected PLMN is present, and the MS is not in the UPDATED state on the selected PLMN.

An LR request indicating Periodic Location Updating is made when, in idle mode, the Periodic Location Updating timer expires while being in the non-GPRS update state UPDATED.

An LR request indicating Periodic Routing Area Update is made when the Periodic Routing Area Update timer expires while being in the GPRS update state UPDATED.

An LR request indicating IMSI attach is made when the MS is activated in the same location area in which it was deactivated while being in the non-GPRS update state UPDATED, and the system information indicates that IMSI attach/detach shall be used.

A GPRS attach is made by a GPRS MS when activated and capable of services which require registration. A GPRS attach may only performed if the selected PLMN is not contained in the list of "forbidden PLMNs for GPRS service". Depending on system information about GPRS network operation mode MSs operating in MS operation mode A or Beapable of GPRS and non-GPRS services perform combined or non-combined location registration procedures. When the combined routing area update or GPRS attach is accepted with indication "MSC not reachable" or is not answered the MS performs also the corresponding location updating procedure or falls back to a GPRS only MS. When the combined routing area update or GPRS attach is rejected with cause "GPRS not allowed" the GPRS update state is

"IDLE, NO IMSI" and the MS performs the corresponding location updating procedure or falls back to a GPRS-only MS.

Furthermore, an LR request indicating Normal Location Updating is also made when the response to an outgoing request shows that the MS is unknown in the VLR or SGSN, respectively.

Table 2 summarizes the events in each state that trigger a new LR request. The actions that may be taken while being in the various states are also outlined in table 2.

Table 2: LR Process States and Allowed Actions

Location registration task state	New LR request when				Normal Calls Supported (1)	Paging responded to
	Changing Cell	Changing registration area	Changing PLMN	Other		
Null (4)	No	Yes	Yes	No	No	No
Updated, (5)	No	Yes	Yes	(2)	Yes	Yes
Idle, No IMSI (7)	No	No	No	No	No	No
Roaming not allowed:						
a) Idle, PLMN not allowed	No	No	Yes	No	No	Optional if with IMSI
b) Idle, LA not allowed	No	Yes(6)	Yes	No	No	Optional if with IMSI
c) Idle, Roaming not allowed in this LA	No	Yes(6)	Yes	No	No	Optional if with IMSI
Not updated	Yes	Yes	Yes	(2)&(3)	(3)	Yes if with IMSI

- 1): Emergency calls may always be made, subject to access control permitting it.
- 2): A new LR is made when the periodic registration timer expires.
- 3): If a normal call request is made, an LR request is made. If successful the updated state is entered and the call may be made.
- 4): The MS is in the null state from switch on until it has camped on a cell and either made an LR attempt or decided that no LR attempt is needed.
- 5): In this state, IMSI detach is performed if the MS is deactivated and the BCCH indicates that IMSI attach/detach shall be used. An LR request indicating IMSI attach is performed if the MS is activated in the same registration area in which it was deactivated while being in this state.
- 6): A GPRS MS shall not perform a new LR when the new routing area is part of a LA contained in a list of forbidden LA.
- 7): The GPRS registration status "Idle, no IMSI" is entered when LR is rejected with cause "GPRS not allowed". The non-GPRS registration status „Idle, no IMSI" is entered when the cause "IMSI unknown in HLR" is received.

A GPRS MS which is both IMSI attached for GPRS and non-GPRS services and which is capable of simultaneous operation of GPRS and non-GPRS services shall perform Routing Area Update in connected mode when it has entered a new routing area which is not part of a LA contained in the list of forbidden LAIs.

4.6.4 IMSI attach/detach operation

The system information will contain an indicator indicating whether or not IMSI attach/detach operation is mandatory to use in the cell. The MS shall operate in accordance with the received value of the indicator.

A GPRS MS shall perform GPRS attach/detach procedures independent of the value of the IMSI attach/detach indicator. When a GPRS MS has to perform IMSI attach/detach independent of GPRS procedures (for example GPRS network operation mode 2) the handling described in the paragraph above applies.

When IMSI attach/detach operation applies, a MS shall send the IMSI detach message to the network when the MS is powered down or the SIM is removed while being in the update state UPDATED. The IMSI detach message will not be acknowledged by the network.

When the MS returns to the active state, the MS shall perform an LR request indicating IMSI attach, provided that the MS still is in the same registration area. If the registration area has changed, an LR request indicating Normal Location Updating according to subclause 4.6.2 shall be performed.

