

3G TS 26.091 V1.0.0 (1999-04)

Technical Specification

**3rd Generation Partnership Project (3GPP)
TSG-SA Codec Working Group
Mandatory Speech Codec speech processing functions
AMR speech codec; Error concealment of lost frames**

3GPP

Reference

TSG-SA4-W1 (<Shortfilename>.PDF)

Keywords

Adaptive Multi-Rate, Mandatory speech coder

3GPP

Postal address

Office address

Internet

secretariat@3gpp.org
Individual copies of this deliverable
can be downloaded from
<http://www.3gpp.org>

Copyright Notification

No part may be reproduced except as authorized by written permission.
The copyright and the foregoing restriction extend to reproduction in all media.

©
All rights reserved.

Contents

Intellectual Property Rights.....	4
Foreword.....	4
1 Scope.....	5
2 Normative references	5
3 Definitions and abbreviations	5
3.1 Definitions	5
3.2 Abbreviations.....	6
4 General.....	6
5 Requirements.....	6
5.1 Error detection	6
5.2 Lost speech frames.....	6
5.3 First lost SID frame	7
5.4 Subsequent lost SID frames.....	7
6 Example ECU/BFH Solution 1.....	7
6.1 State Machine	7
6.2 Assumed Active Speech Frame Error Concealment Unit Actions	8
6.2.1 BFI = 0, prevBFI = 0, State = 0.....	8
6.2.2 BFI = 0, prevBFI = 1, State = 0 or 5	9
6.2.3 BFI = 1, prevBFI = 0 or 1, State = 1...6.....	9
6.2.3.2 Innovation sequence	10
6.3 Assumed Non-Active Speech Signal Error Concealment Unit Actions.....	10
6.3.1 General	10
6.3.2 Detectors	10
6.3.3 Background ECU Actions.....	10
6.4 Substitution and muting of lost SID frames.....	11
7 Example ECU/BFH Solution 2.....	11
7.1 State Machine	11
7.2 Substitution and muting of lost speech frames	11
7.2.1 BFI = 0, prevBFI = 0, State = 0.....	11
7.2.2 BFI = 0, prevBFI = 1, State = 0 or 5	11
7.2.3 BFI = 1, prevBFI = 0 or 1, State = 1...6.....	12
7.2.4 Innovation sequence	12
7.3 Substitution and muting of lost SID frames.....	13
History.....	14

Intellectual Property Rights

Foreword

This Technical Specification has been produced by the 3rd Generation Partnership Project, Technical Specification Group Services and System Aspects, Working Group 4 (Codec).

The contents of this informal TS may be subject to continuing work within the 3GPP and may change following formal TSG-S4 approval. Should TSG-S4 modify the contents of this TS, it will be re-released with an identifying change of release date and an increase in version number as follows:

Version m.t.e

where:

- m indicates [major version number]
- x the second digit is incremented for all changes of substance, i.e. technical enhancements, corrections, updates, etc.
- y the third digit is incremented when editorial only changes have been incorporated into the specification.

1 Scope

This specification defines an error concealment procedure, also termed frame substitution and muting procedure, which shall be used by the AMR speech codec receiving end when one or more lost speech or lost Silence Descriptor (SID) frames are received.

The requirements of this document are mandatory for implementation in all networks and User Equipment (UE)s capable of supporting the AMR speech codec. It is not mandatory to follow the bit exact implementation outlined in this document and the corresponding C source code.

2 Normative references

This document incorporates, by dated and undated reference, provisions from other publications. These normative references are cited in the appropriate places in the text and the publications are listed hereafter. For dated references, subsequent amendments to or revisions of any of these publications apply to this document only when incorporated in it by amendment or revision. For undated references, the latest edition of the publication referred to applies.

- [1] 3G TS 26.102 "AMR Speech Codec; Interface to RAN".
- [2] 3G TS 26.090 "AMR Speech Codec; Transcoding functions".
- [3] 3G TS 26.093 "AMR Speech Codec; Source Controlled Rate operation".
- [4] 3G TS 26.101 "AMR Speech Codec; Frame structure".

3 Definitions and abbreviations

3.1 Definitions

For the purposes of this document, the following definition applies:

N-point median operation: Consists of sorting the N elements belonging to the set for which the median operation is to be performed in an ascending order according to their values, and selecting the $(\text{int}(N/2) + 1)$ -th largest value of the sorted set as the median value.

Further definitions of terms used in this document can be found in the references.

3.2 Abbreviations

For the purposes of this document, the following abbreviations apply:

AN	Access Network
BFI	Bad Frame Indication from AN
BSI_netw	Bad Sub-block Indication obtained from AN interface CRC checks
prevBFI	Bad Frame Indication of previous frame
PDFI	Potentially Degraded Frame Indication
RX	Receive
SCR	Source Controlled Rate (operation)
SID	Silence Descriptor frame (Background descriptor)
CRC	Cyclic Redundancy Check
ECU	Error Concealment Unit
BFH	Bad Frame Handling
medianN	N-point median operation

4 General

The purpose of the error concealment procedure is to conceal the effect of lost AMR speech frames. The purpose of muting the output in the case of several lost frames is to indicate the breakdown of the channel to the user and to avoid generating possible annoying sounds as a result from the error concealment procedure.

The network shall indicate lost speech or lost SID frames by setting the RX_TYPE values [3] to SPEECH_BAD or SID_BAD. If these flags are set, the speech decoder shall perform parameter substitution to conceal errors.

The network should also indicate potentially degraded frames using the flag RX_TYPE value SPEECH_PROBABLY_DEGRADED. This flag may be derived from channel quality indicators. It may be used by the speech decoder selectively depending on the estimated signal type.

The example solutions provided in paragraphs 6 and 7 apply only to bad frame handling on a complete speech frame basis. Sub-frame based error concealment may be derived using similar methods.

5 Requirements

5.1 Error detection

If the most sensitive bits of the AMR speech data (class A in [4]) are received in error, the network shall indicate RX_TYPE = SPEECH_BAD in which case the BFI flag is set. If a SID frame is received in error, the network shall indicate RX_TYPE = SID_BAD in which case the BFI flag is also set. The RX_TYPE = SPEECH_PROBABLY_DEGRADED flag should be set appropriately using quality information from the channel decoder, in which case the PDFI flag is set.

5.2 Lost speech frames

Normal decoding of lost speech frames would result in very unpleasant noise effects. In order to improve the subjective quality, lost speech frames shall be substituted with either a repetition or an extrapolation of the previous good speech frame(s). This substitution is done so that it gradually will decrease the output level, resulting in silence at the output. Subclauses 6, and 7 provide example solutions.

5.3 First lost SID frame

A lost SID frame shall be substituted by using the SID information from earlier received valid SID frames and the procedure for valid SID frames be applied as described in [3].

5.4 Subsequent lost SID frames

For many subsequent lost SID frames, a muting technique shall be applied to the comfort noise that will gradually decrease the output level. For subsequent lost SID frames, the muting of the output shall be maintained. Subclauses 6 and 7 provide example solutions.

6 Example ECU/BFH Solution 1

The C code of the following example is embedded in the bit exact software of the codec. In the code the ECU is designed to allow subframe-by-subframe synthesis, thereby reducing the speech synthesis delay to a minimum.

6.1 State Machine

This example solution for substitution and muting is based on a state machine with seven states (Figure 1).

The system starts in state 0. Each time a bad frame is detected, the state counter is incremented by one and is saturated when it reaches 6. Each time a good speech frame is detected, the state counter is reset to zero, except when we are in state 6, where we set the state counter to 5. The state indicates the quality of the channel: the larger the value of the state counter, the worse the channel quality is. The control flow of the state machine can be described by the following C code (**BFI** = bad frame indicator, **State** = state variable):

```
if(BFI != 0 )
    State = State + 1;
else if(State == 6)
    State = 5;
else
    State = 0;
if(State > 6 )
    State = 6;
```

In addition to this state machine, the **Bad Frame Flag** from the previous frame is checked (**prevBFI**). The processing depends on the value of the **State**-variable. In states 0 and 5, the processing depends also on the two flags **BFI** and **prevBFI**.

The procedure can be described as follows:

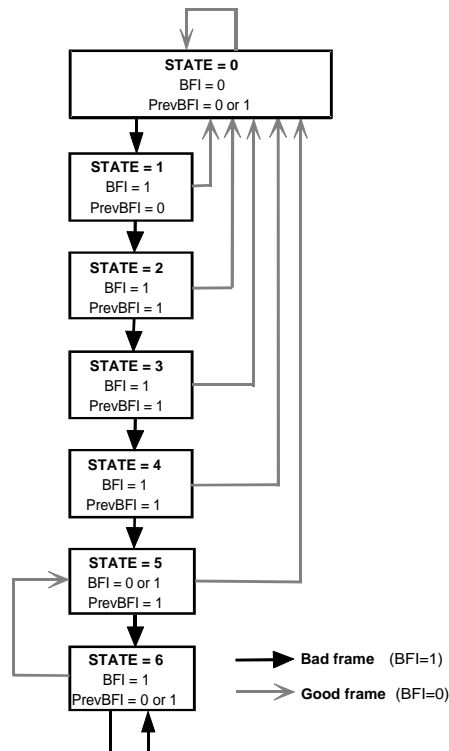

Figure 1: State machine for controlling the bad frame substitution

6.2 Assumed Active Speech Frame Error Concealment Unit Actions

6.2.1 BFI = 0, prevBFI = 0, State = 0

No error is detected in the received or in the previous received speech frame. The received speech parameters are used in the normal way in the speech synthesis. The current frame of speech parameters is saved.

6.2.2 BFI = 0, prevBFI = 1, State = 0 or 5

No error is detected in the received speech frame, but the previous received speech frame was bad. The LTP gain and fixed codebook gain are limited below the values used for the last received good

$$\text{subframe: } g^p = \begin{cases} g^p, & g^p \leq g^p(-1) \\ g^p(-1), & g^p > g^p(-1) \end{cases} \quad (1)$$

where g^p = current decoded LTP gain, $g^p(-1)$ = LTP gain used for the last good subframe (BFI = 0), and

$$g^c = \begin{cases} g^c, & g^c \leq g^c(-1) \\ g^c(-1), & g^c > g^c(-1) \end{cases} \quad (2)$$

where g^c = current decoded fixed codebook gain and $g^c(-1)$ = fixed codebook gain used for the last good subframe (BFI = 0).

The rest of the received speech parameters are used normally in the speech synthesis. The current frame of speech parameters is saved.

6.2.3 BFI = 1, prevBFI = 0 or 1, State = 1...6

An error is detected in the received speech frame and the substitution and muting procedure is started. The LTP gain and fixed codebook gain are replaced by attenuated values from the previous subframes:

$$g^p = \begin{cases} P(\text{state}) g^p(-1), & g^p(-1) \leq \text{median5}(g^p(-1), \dots, g^p(-5)) \\ P(\text{state}) \text{median5}(g^p(-1), \dots, g^p(-5)), & g^p(-1) > \text{median5}(g^p(-1), \dots, g^p(-5)) \end{cases} \quad (3)$$

where g^p = current decoded LTP gain, $g^p(-1), \dots, g^p(-n)$ = LTP gains used for the last n subframes, $\text{median5}()$ = 5-point median operation, $P(\text{state})$ = attenuation factor ($P(1) = 0.98$, $P(2) = 0.98$, $P(3) = 0.8$, $P(4) = 0.3$, $P(5) = 0.2$, $P(6) = 0.2$), state = state number, and

$$g^c = \begin{cases} C(\text{state}) g^c(-1), & g^c(-1) \leq \text{median5}(g^c(-1), \dots, g^c(-5)) \\ C(\text{state}) \text{median5}(g^c(-1), \dots, g^c(-5)), & g^c(-1) > \text{median5}(g^c(-1), \dots, g^c(-5)) \end{cases} \quad (4)$$

where g^c = current decoded fixed codebook gain, $g^c(-1), \dots, g^c(-n)$ = fixed codebook gains used for the last n subframes, $\text{median5}()$ = 5-point median operation, $C(\text{state})$ = attenuation factor ($C(1) = 0.98$, $C(2) = 0.98$, $C(3) = 0.98$, $C(4) = 0.98$, $C(5) = 0.98$, $C(6) = 0.7$), and state = state number.

The higher the state value is, the more the gains are attenuated. Also the memory of the predictive fixed codebook gain is updated by using the average value of the past four values in the memory:

$$\text{ener}(0) = \frac{1}{4} \sum_{i=1}^4 \text{ener}(-i) \quad (5)$$

The past LSFs are shifted towards their mean:

$$\text{lsf_q1}(i) = \text{lsf_q2}(i) = \alpha \text{past_lsf_q}(i) + (1 - \alpha) \text{mean_lsf}(i), \quad i = 0..9 \quad (6)$$

where $\alpha = 0.95$, lsf_q1 and lsf_q2 are two sets of LSF-vectors for current frame, past_lsf_q is lsf_q2 from the previous frame, and mean_lsf is the average LSF-vector. Note that two sets of LSFs are available only in the 12.2 mode.

6.2.3.1 LTP-lag update

The LTP-lag values are replaced by the past value from the 4th subframe of the previous frame (12.2 mode) or slightly modified values based on the last correctly received value (all other modes).

6.2.3.2 Innovation sequence

The received fixed codebook innovation pulses from the erroneous frame are always used in the state in which they were received.

6.3 Assumed Non-Active Speech Signal Error Concealment Unit Actions

6.3.1 General

The Non-Active Speech ECU is used to reduce the negative impact of amplitude variations and tonal artifacts when using the conventional Active Speech ECU in non-voiced signals such as background noise and unvoiced speech. The background ECU actions are only used for the lower rate Speech Coding modes.

The Non-Active Speech ECU actions are done as postprocessing actions of the Active Speech ECU, actions thus ensuring that the Active Speech ECU states are continuously updated. This will guarantee instant and seamless switching to the Active Speech ECU. The detectors and state updates have to be running continuously for all speech coding modes to avoid switching problems.

Only the differences to the Active Speech ECU are stated below.

6.3.2 Detectors

6.3.2.1 Background detector

An energy level and energy change detector is used to monitor the signal. If the signal is considered to contain background noise and only shows minor energy level changes, a flag is set. The resulting indicator is the **inBackgroundNoise** flag which indicates the signal state of the previous frame.

6.3.2.2 Voicing detector

The received LTP gain is monitored and used to prevent the use of the background ECU actions in possibly voiced segments. A median filtered LTP gain value with a varying filter memory length is thresholded to provide the correct voicing decision. Additionally, a counter **voicedHangover** is used to monitor the time since a frame was presumedly voiced.

6.3.3 Background ECU Actions

The BFI, and DFI indications are used together with the flag **inBackgroundNoise** and the counter **voicedHangover** to adjust the LTP part and the innovation part of the excitation. The actions are only taken if the previous frame has been classified as background noise and sufficient time has passed since the last voiced frame was detected.

The background ECU actions are: energy control of the excitation signal, relaxed LTP lag control, stronger limitation of the LTP gain, adjusted adaptation of the Gain-Contour-Smoothing algorithm and modified adaptation of the Anti-Sparseness Procedure.

6.4 Substitution and muting of lost SID frames

In the speech decoder a single frame classified as SID_BAD shall be substituted by the last valid SID frame information and the procedure for valid SID frames be applied. If the time between SID information updates (updates are specified by SID_UPDATE arrivals and occasionally by SID_FIRST arrivals see 06.92) is greater than one second this shall lead to attenuation.

7 Example ECU/BFH Solution 2

This is an alternative example solution which is a simplified version of Example ECU/BFH Solution 1.

7.1 State Machine

This example solution for substitution and muting is based on a state machine with seven states (Figure 1, same state machine as in Example 1).

The system starts in state 0. Each time a bad frame is detected, the state counter is incremented by one and is saturated when it reaches 6. Each time a good speech frame is detected, the state counter is reset to zero, except when we are in state 6, where we set the state counter to 5. The state indicates the quality of the channel: the larger the state counter, the worse the channel quality is. The control flow of the state machine can be described by the following C code (**BFI** = bad frame indicator, **State** = state variable):

```

if(BFI != 0 )
    State = State + 1;
else if(State == 6)
    State = 5;
else
    State = 0;
if(State > 6 )
    State = 6;

```

In addition to this state machine, the **Bad Frame Flag** from the previous frame is checked (**prevBFI**). The processing depends on the value of the **State**-variable. In states 0 and 5, the processing depends also on the two flags **BFI** and **prevBFI**.

7.2 Substitution and muting of lost speech frames

7.2.1 BFI = 0, prevBFI = 0, State = 0

No error is detected in the received or in the previous received speech frame. The received speech parameters are used normally in the speech synthesis. The current frame of speech parameters is saved.

7.2.2 BFI = 0, prevBFI = 1, State = 0 or 5

No error is detected in the received speech frame but the previous received speech frame was bad. The LTP gain and fixed codebook gain are limited below the values used for the last received good subframe:

$$g^p = \begin{cases} g^p, & g^p \leq g^p(-1) \\ g^p(-1), & g^p > g^p(-1) \end{cases} \quad (7)$$

where g^p = current decoded LTP gain, $g^p(-1)$ = LTP gain used for the last good subframe (BFI = 0), and

$$g^c = \begin{cases} g^c, & g^c \leq g^c(-1) \\ g^c(-1), & g^c > g^c(-1) \end{cases} \quad (8)$$

where g^c = current decoded fixed codebook-gain and $g^c(-1)$ = fixed codebook gain used for the last good subframe (BFI = 0).

The rest of the received speech parameters are used normally in the speech synthesis. The current frame of speech parameters is saved.

7.2.3 BFI = 1, prevBFI = 0 or 1, State = 1...6

An error is detected in the received speech frame and the substitution and muting procedure is started. The LTP gain and fixed codebook gain are replaced by attenuated values from the previous subframes:

$$g^p = \begin{cases} P(state) g^p(-1), & g^p(-1) \leq \text{median5}(g^p(-1), \dots, g^p(-5)) \\ P(state) \text{median5}(g^p(-1), \dots, g^p(-5)), & g^p(-1) > \text{median5}(g^p(-1), \dots, g^p(-5)) \end{cases} \quad (9)$$

where g^p = current decoded LTP gain, $g^p(-1), \dots, g^p(-n)$ = LTP gains used for the last n subframes, $\text{median5}()$ = 5-point median operation, $P(state)$ = attenuation factor ($P(1) = 0.98$, $P(2) = 0.98$, $P(3) = 0.8$, $P(4) = 0.3$, $P(5) = 0.2$, $P(6) = 0.2$), $state$ = state number, and

$$g^c = \begin{cases} C(state) g^c(-1), & g^c(-1) \leq \text{median5}(g^c(-1), \dots, g^c(-5)) \\ C(state) \text{median5}(g^c(-1), \dots, g^c(-5)), & g^c(-1) > \text{median5}(g^c(-1), \dots, g^c(-5)) \end{cases} \quad (10)$$

where g^c = current decoded fixed codebook gain, $g^c(-1), \dots, g^c(-n)$ = fixed codebook gains used for the last n subframes, $\text{median5}()$ = 5-point median operation, $C(state)$ = attenuation factor ($C(1) = 0.98$, $C(2) = 0.98$, $C(3) = 0.98$, $C(4) = 0.98$, $C(5) = 0.98$, $C(6) = 0.7$), and $state$ = state number.

The higher the state value is, the more the gains are attenuated. Also the memory of the predictive fixed codebook gain is updated by using the average value of the past four values in the memory:

$$\text{ener}(0) = \frac{1}{4} \sum_{i=1}^4 \text{ener}(-i) \quad (11)$$

The past LSFs are used by shifting their values towards their mean:

$$\text{lsf}_q1(i) = \text{lsf}_q2(i) = \alpha \text{past_lsf}_q(i) + (1 - \alpha) \text{mean_lsf}(i), \quad i = 0..9 \quad (12)$$

where $\alpha = 0.95$, lsf_q1 and lsf_q2 are two sets of LSF-vectors for current frame, past_lsf_q is lsf_q2 from the previous frame, and mean_lsf is the average LSF-vector. Note that two sets of LSFs are available only in the 12.2 mode.

7.2.3.1 LTP-lag update

The LTP-lag values are replaced by the past value from the 4th subframe of the previous frame (12.2 mode) or slightly modified values based on the last correctly received value (all other modes).

7.2.4 Innovation sequence

The received fixed codebook innovation pulses from the erroneous frame are always used in the state in which they were received.

7.3 Substitution and muting of lost SID frames

In the speech decoder a single frame classified as SID_BAD shall be substituted by the last valid SID frame information and the procedure for valid SID frames be applied. If the time between SID information updates (updates are specified by SID_UPDATE arrivals and occasionally by SID_FIRST arrivals) is greater than one second this shall lead to attenuation.

History

Document history		
V. 0.1.0	March 1999	First Draft, based on GSM 06.91 2.0.0, BSI_abis -> BSI_netw
V. 0.1.1	April 1999	References changed , RAN changed to AN
V. 1.0.0	April 22, 1999	Minor editorial changes