

**Agenda item:** AH 16  
**Source:** Ericsson  
**Title:** CR 25.215-007: Ranges and resolution of timing measurements  
**Document for:** Decision

## 1. Introduction

The aim of this document is to define ranges for some timing measurements in TS 25.215.

## 2. UE Rx-Tx time difference and Round trip time

In figure 1 the internal timing in the UE is shown. The UE is in soft handover with 3 radio links in the active set, indexed i, j and k in the figure.

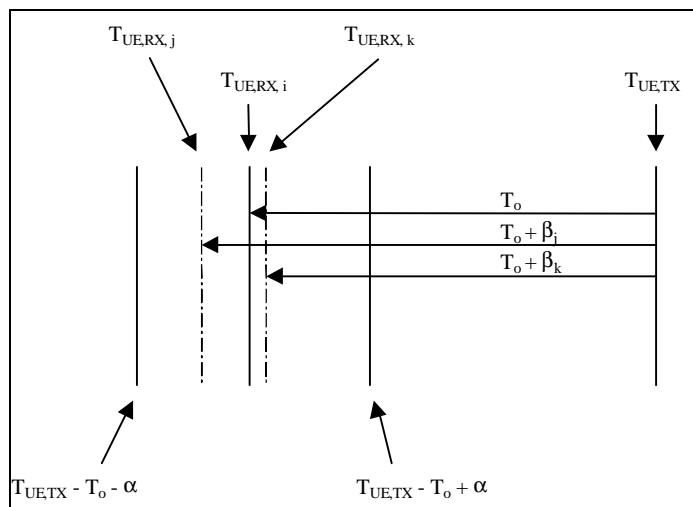

**Figure 1 UE internal timing**

The receiving window in the UE is set to  $2\alpha$  where  $\alpha=(128+20)=148$  chips, see TS 25.214 section 4.3.3. The UE Rx-Tx timing is defined as the difference in time between the  $T_{UE,TX}$  and the time for reception of the downlink frame from the cells in the active set, e.g.:  $T_{UE,TX} - T_{UE,RX}$ , where:

$T_{UE,TX}$  is the time when the UE transmits an uplink DPCCH/DPDCH frame.

$T_{UE,RX}$  is the time when the first significant path of the downlink DPCH frame from the measured radio link is received in the UE.

$T_0$  is defined in TS 25.211 section 7.1.3 and equals 1024 chips.

The UE Rx-Tx time difference will therefore always be within the interval  $T_0 \pm \alpha$ .

As the UE Rx-Tx time difference is intended to be used for positioning applications and taking into account that the SFN-SFN observed time difference type 2 has a resolution of  $\frac{1}{2}$  chip, it is proposed that this is valid also for the UE Rx-Tx time difference measurement.

- The UE Rx-Tx time difference is given with the resolution of  $\frac{1}{2}$  chip with the range [876

### 3. Observed time difference to GSM cell

The measurement of “Observed time difference to GSM cell” is shown in figure 1.

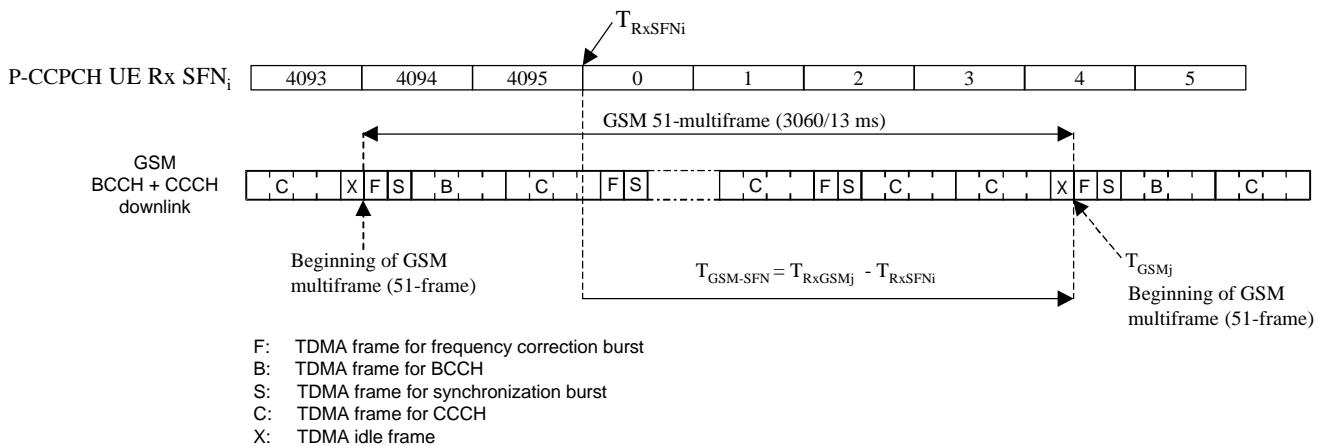

**Figure 2 Measuring the Observed time difference to GSM cell**

As the GSM 51-multiframe structure is repeated every 51 GSM frames, the upper range for the measurement is one multiframe, e.g. 3060/13 ms. One possible usage of the measurement is to position the CM-pattern for measuring on GSM cells. As positioning is made in entire slots an upper limit of the resolution could be something like half a slot ~ 1/3 ms. There could be gain by being able to schedule the measurements with a finer resolution if several GSM-cells shall be measured within a TGL. A resolution of  $1/13\text{ms} \approx 76.9 \mu\text{s}$  (approx. 0.13 GSM slots) will give 3060 values of the timing measurement, requiring 12 bits. With 12 bits 4096 values can be represented and therefore it is proposed to divide the range of the measurement into 4096 intervals corresponding to a resolution of  $3060/(4096*13) \text{ms} \approx 57.5 \mu\text{s}$  (approx. 0.1 GSM-slot).

The Observed time difference to GSM cell is given with the resolution of  $3060/(4096*13) \text{ms}$  with the range  $[0, \dots, 3060/13-3060/(4096*13)] \text{ms}$ .

# CHANGE REQUEST

Please see embedded help file at the bottom of this page for instructions on how to fill in this form correctly.

**25.215 CR 007**

Current Version: **3.0.0**

GSM (AA.BB) or 3G (AA.BBB) specification number ↑

↑ CR number as allocated by MCC support team

For submission to: **TSG-RAN #6** for approval   
 list expected approval meeting # here ↑ for information

strategic  (for SMG use only)  
 non-strategic

Form: CR cover sheet, version 2 for 3GPP and SMG The latest version of this form is available from: <ftp://ftp.3gpp.org/Information/CR-Form-v2.doc>

**Proposed change affects:** (U)SIM  ME  UTRAN / Radio  Core Network   
 (at least one should be marked with an X)

**Source:** Ericsson **Date:** 1999-10-25

**Subject:** Ranges and resolution of timing measurements

**Work item:**

**Category:** F Correction  **Release:** Phase 2   
 A Corresponds to a correction in an earlier release  Release 96   
 (only one category shall be marked with an X) B Addition of feature  Release 97   
 C Functional modification of feature  Release 98   
 D Editorial modification  Release 99   
 Release 00

**Reason for change:** Define range and resolution for three timing measurements in TS 25.215, namely UE Rx-Tx time difference, Round trip time and Observed time difference to GSM cell.

**Clauses affected:** 5.1 UE measurement abilities  
 5.2.7 Round trip time

**Other specs affected:** Other 3G core specifications  → List of CRs:  
 Other GSM core specifications  → List of CRs:  
 MS test specifications  → List of CRs:  
 BSS test specifications  → List of CRs:  
 O&M specifications  → List of CRs:

**Other comments:**



help.doc

<----- double-click here for help and instructions on how to create a CR.

### 5.1.11 CFN-SFN observed time difference

Definition	<p>The CFN-SFN observed time difference to cell is defined as: <math>OFF \times 38400 + T_m</math>, where:</p> <p><math>T_m = T_{RxSFN} - (T_{UETx} - T_0)</math>, given in chip units with the range [0, 1, ..., 38399] chips</p> <p><math>T_{UETx}</math> is the time when the UE transmits an uplink DPCCCH/DPDCH frame.</p> <p><math>T_0</math> is defined in TS 25.211 section 7.1.3.</p> <p><math>T_{RxSFN}</math> is time at the beginning of the next received neighbouring P-CCPCH frame after the time instant <math>T_{UETx} - T_0</math> in the UE. If the next neighbouring P-CCPCH frame is received exactly at <math>T_{UETx} - T_0</math> then <math>T_{RxSFN} = T_{UETx} - T_0</math> (which leads to <math>T_m = 0</math>).</p> <p>and</p> <p><math>OFF = (CFN_{Tx} - SFN) \bmod 256</math>, given in number of frames with the range [0, 1, ..., 255] frames</p> <p><math>CFN_{Tx}</math> is the connection frame number for the UE transmission of an uplink DPCCCH/DPDCH frame at the time <math>T_{UETx}</math>.</p> <p><math>SFN</math> = the system frame number for the neighbouring P-CCPCH frame received in the UE at the time <math>T_{RxSFN}</math>.</p>
Applicable for	Connected Inter, Connected Intra
Range/mapping	Time difference is given with the resolution of one chip with the range [0, ..., 9830399] chips.

### 5.1.12 SFN-SFN observed time difference

Definition	<p><b>Type 1:</b></p> <p>The SFN-SFN observed time difference to cell is defined as: <math>OFF \times 38400 + T_m</math>, where:</p> <p><math>T_m = T_{RxSFNj} - T_{RxSFNi}</math>, given in chip units with the range [0, 1, ..., 38399] chips</p> <p><math>T_{RxSFNj}</math> is the time at the beginning of a received neighbouring P-CCPCH frame from cell j.</p> <p><math>T_{RxSFNi}</math> is time at the beginning of the next received neighbouring P-CCPCH frame from cell i after the time instant <math>T_{RxSFNj}</math> in the UE. If the next neighbouring P-CCPCH frame is received exactly at <math>T_{RxSFNj}</math> then <math>T_{RxSFNj} = T_{RxSFNi}</math> (which leads to <math>T_m = 0</math>).</p> <p>and</p> <p><math>OFF = (SFN_j - SFN_i) \bmod 256</math>, given in number of frames with the range [0, 1, ..., 255] frames</p> <p><math>SFN_j</math> = the system frame number for downlink P-CCPCH frame from cell j in the UE at the time <math>T_{RxSFNj}</math>.</p> <p><math>SFN_i</math> = the system frame number for the P-CCPCH frame from cell i received in the UE at the time <math>T_{RxSFNi}</math>.</p> <p><b>Type 2:</b></p> <p>The relative timing difference between cell j and cell i, defined as <math>T_{CPICHRxj} - T_{CPICHRxi}</math>, where:</p> <p><math>T_{CPICHRxj}</math> is the time when the UE receives one CPICH slot from cell j</p> <p><math>T_{CPICHRxi}</math> is the time when the UE receives the CPICH slot from cell i that is closest in time to the CPICH slot received from cell j</p>
Applicable for	<p><b>Type 1:</b> Idle, Connected Intra</p> <p><b>Type 2:</b> Idle, Connected Intra, Connected Inter</p>
Range/mapping	<p><b>Type 1:</b> Time difference is given with a resolution of one chip with the range [0, ..., 9830399] chips.</p> <p><b>Type 2:</b> Time difference is given with a resolution of 0.5 chip with the range [-1279, ..., 1280] chips.</p>

### 5.1.13 UE Rx-Tx time difference

Definition	<p>The difference in time between the UE uplink DPCCCH/DPDCH frame transmission and the first significant path, of the downlink DPCH frame from the measured radio link. Measurement shall be made for each cell included in the active set.</p> <p>Note: The definition of "first significant path" needs further elaboration.</p>
Applicable for	Connected Intra
Range/mapping	<del>Always positive.</del> The UE Rx-Tx time difference is given with the resolution of 1 chip with the range [876, ..., 1172] chips.

### 5.1.15 Observed time difference to GSM cell

<b>Definition</b>	The Observed time difference to GSM cell is defined as: $T_{RxGSMj} - T_{RxSFNi}$ , where: $T_{RxSFNi}$ is the time at the beginning of the P-CCPCH frame with SFN=0 from cell i. $T_{RxGSMj}$ is the time at the beginning of the GSM BCCH 51-multiframe from GSM cell j received closest in time after the time $T_{RxSFNi}$ . If the next GSM multiframe is received exactly at $T_{RxSFNi}$ then $T_{RxGSMj} = T_{RxSFNi}$ (which leads to $T_{RxGSMj} - T_{RxSFNi} = 0$ ). GSM cell j is defined by the BCCH frequency and the BSIC used in the cell.
<b>Applicable for</b>	Idle, Connected Inter
<b>Range/mapping</b>	The Observed time difference to GSM cell is given with the resolution of $3060/(4096*13)$ ms with the range $[0, \dots, 3060/13 - 3060/(4096*13)]$ ms.

## 5.2 UTRAN measurement abilities

The structure of the table defining a UTRAN measurement quantity is shown below:

Column field	Comment
<b>Definition</b>	Contains the definition of the measurement.
<b>Range/mapping</b>	Gives the range and mapping to bits for the measurements quantity.

### 5.2.1 RSSI

<b>Definition</b>	Received Signal Strength Indicator, the wide-band received power within the UTRAN uplink carrier channel bandwidth in an UTRAN access point. The reference point for the RSSI measurements shall be the antenna connector.
<b>Range/mapping</b>	

### 5.2.2 SIR

<b>Definition</b>	Signal to Interference Ratio, is defined as the RSCP divided by the ISCP. Measurement shall be performed on the DPCCH after RL combination in Node B. The reference point for the SIR measurements shall be the antenna connector.
<b>Range/mapping</b>	

### 5.2.3 Transmitted carrier power

<b>Definition</b>	Transmitted carrier power, is the total transmitted power on one carrier from one UTRAN access point. Measurement shall be possible on any carrier transmitted from the UTRAN access point. The reference point for the total transmitted power measurement shall be the antenna connector. In case of Tx diversity the total transmitted power for each branch shall be measured.
<b>Range/mapping</b>	

### 5.2.4 Transmitted code power

<b>Definition</b>	Transmitted code power, is the transmitted power on one carrier, one scrambling code and one channelisation code. Measurement shall be possible on any channelisation code transmitted from the UTRAN access point. The reference point for the transmitted code power measurement shall be the antenna connector. In case of Tx diversity the transmitted code power for each branch shall be measured.
<b>Range/mapping</b>	

## 5.2.5 Transport channel BLER

Definition	Estimation of the transport channel block error rate (BLER). The BLER estimation shall be based on evaluating the CRC on each transport block. Measurement shall be possible to perform on any transport channel after RL combination in Node B. BLER estimation is only required for transport channels containing CRC.
Range/mapping	

## 5.2.6 Physical channel BER

Definition	The physical channel BER is an estimation of the average bit error rate (BER) before channel decoding of the DPDCH data after RL combination in Node B. It shall be possible to report a physical channel BER estimate at the end of each TTI for the transferred TrCh's, e.g. for TrCh's with a TTI of x ms a x ms averaged physical channel BER shall be possible to report every x ms.
Range/mapping	

## 5.2.7 Round trip time

**Note: The relation between this measurement and the TOA measurement defined by WG2 needs clarification.**

Definition	<p>Round trip time (RTT), is defined as</p> $RTT = T_{RX} - T_{TX},$ <p>where</p> <p><math>T_{TX}</math> = The time of transmission of the beginning of a downlink DPCH frame to a UE.</p> <p><math>T_{RX}</math> = The time of reception of the beginning (the first significant path) of the corresponding uplink DPCCH/DPDCH frame from the UE.</p> <p>Note: The definition of "first significant path" needs further elaboration.</p> <p>Measurement shall be possible on DPCH for each RL transmitted from an UTRAN access point and DPDCH/DPCCH for each RL received in the same UTRAN access point.</p>
Range/mapping	<u>The Round trip time is given with the resolution of 1/6chip with the range [876 ..., 2923.5] chips.</u>