

CHANGE REQUEST

25.415 CR 124 rev 3 Current version: 6.1.0

For **HELP** on using this form, see bottom of this page or look at the pop-up text over the symbols.

Proposed change affects: | UICC apps ME Radio Access Network Core Network

Title:	Clarification of Initialisation and Rate Control for lu user plane version one		
Source:	Ericsson, NEC, Siemens		
Work item code:	TEI6	Date:	07/03/2005
Category:	F	Release:	Rel-6
	<p>Use <u>one</u> of the following categories:</p> <p>F (correction)</p> <p>A (corresponds to a correction in an earlier release)</p> <p>B (addition of feature),</p> <p>C (functional modification of feature)</p> <p>D (editorial modification)</p> <p>Detailed explanations of the above categories can be found in 3GPP TR 21.900.</p>		<p>Use <u>one</u> of the following releases:</p> <p>Ph2 (GSM Phase 2)</p> <p>R96 (Release 1996)</p> <p>R97 (Release 1997)</p> <p>R98 (Release 1998)</p> <p>R99 (Release 1999)</p> <p>Rel-4 (Release 4)</p> <p>Rel-5 (Release 5)</p> <p>Rel-6 (Release 6)</p> <p>Rel-7 (Release 7)</p>

Reason for change:	<p>In case of user plane version one it is allowed to <i>initialise just a subset of the requested RAB sub-Flow Combinations</i>. However, the rate control procedure specifies that only rates above the guaranteed bitrate can be rate controlled / forbidden and that the lowest speech rate cannot be controlled (i.e. cannot be forbidden) by the SRNC. This could lead to the interpretation, that in case a RNC decides to initiate UP version 1 the guaranteed bit rate has to be allowed in any case, even if the RNC intends to allow only a single DL rate above the guaranteed bit rate.</p>
Summary of change:	<p>It is clarified that for UP version 1 at least one of the requested RAB sub-Flow Combinations equal or above the guaranteed bitrate shall be initialised. Further it is clarified in the rate control procedure, that the procedure text regarding the guaranteed bitrate does not hold in UP version 1.</p> <p><u>Impact assessment towards the previous version of the specification (same release):</u></p> <p>This CR has isolated impact on the previous version of the specification (same release).</p> <p>This CR has an impact under protocol point of view.</p> <p>The impact can be considered as isolated as it clarifies only rate control and initialisation constraints.</p>
Consequences if	<p>Potential IOT issues for rate control in case lu UP V1 is used.</p>

not approved:

Clauses affected:	⌘	7.5.2.1, 7.5.3.1										
Other specs affected:	⌘	<table border="1"> <tr> <td>Y</td> <td>N</td> </tr> <tr> <td></td> <td>X</td> </tr> <tr> <td></td> <td>X</td> </tr> <tr> <td></td> <td>X</td> </tr> </table>	Y	N		X		X		X	Other core specifications	⌘
		Y	N									
			X									
	X											
	X											
			Test specifications									
			O&M Specifications									
Other comments:	⌘											

How to create CRs using this form:

Comprehensive information and tips about how to create CRs can be found at <http://www.3gpp.org/specs/CR.htm>. Below is a brief summary:

- 1) Fill out the above form. The symbols above marked ⌘ contain pop-up help information about the field that they are closest to.
- 2) Obtain the latest version for the release of the specification to which the change is proposed. Use the MS Word "revision marks" feature (also known as "track changes") when making the changes. All 3GPP specifications can be downloaded from the 3GPP server under <ftp://ftp.3gpp.org/specs/>. For the latest version, look for the directory name with the latest date e.g. 2001-03 contains the specifications resulting from the March 2001 TSG meetings.
- 3) With "track changes" disabled, paste the entire CR form (use CTRL-A to select it) into the specification just in front of the clause containing the first piece of changed text. Delete those parts of the specification which are not relevant to the change request.

6.5.2 Initialisation procedure

6.5.2.1 Successful operation

This procedure is mandatory for RABs using the support mode for predefined SDU size. The purpose of the Initialisation procedure is to configure both termination points of the Iu UP with RAB Subflows Combinations, RFCIs, and associated RAB Sub Flows SDU sizes necessary to be supported during the transfer of user data phase.

Additional parameters may also be passed, such as the Inter PDU Timing Interval (IPTI) information.

The Initialisation procedure may be controlled at both end of the Iu access point, i.e. the CN and UTRAN.

The Initialisation procedure is invoked whenever indicated by the Iu UP Procedure Control function e.g. as a result of a relocation of SRNS or at RAB establishment over Iu or if the CN decides to resolve RFCI mismatch in case of TrFO (see [13]). The Initialisation procedure shall not be re-invoked by the SRNC for the RAB without a RAB modification requested via RANAP [3].

When this procedure is invoked all other Iu UP procedures are suspended until termination of the Initialisation procedure.

The Iu UP protocol entity invoking this procedure shall indicate the Iu UP Mode version it uses for the initialisation as well as the Iu UP Mode versions it supports for the related RAB among the versions the CN requested for the related RAB. The sender should use the lowest version for the initialisation that has enough information to initialise the highest proposed protocol version.

The invoking entity allocates a RAB sub-Flow Combination indicator (RFCI) to each RAB sub-Flow Combination it initialises. One requirement on which RAB sub-Flow Combinations to initialise, is that all requested compound RAB sub-Flow Combination SDU sizes shall be configured, except in the case when also version 1 of the user plane mode was included as an alternative in the request over RANAP. In that case, it is allowed to initialise just a subset of the requested RAB sub-Flow Combinations, [however at least one of the requested RAB sub-Flow Combinations equal or above the guaranteed bitrate shall be initialised](#). The association of indicators to RAB Flow Combinations is valid for both the uplink and downlink direction in the Iu UP until a new Initialisation procedure is performed or the connection is terminated.

The Procedure Control function may also generate additional Iu UP protocol parameters necessary for the RAB service to operate properly over Iu.

To each RAB sub-Flow combination indicator is associated the size of each RAB sub-Flow SDU of that combination. The list of RAB sub-Flow Combination Indicators and their respective SDU sizes constitutes the RAB sub-Flow Combination set passed over the Iu UP in the INITIALISATION control frame i.e. into an appropriate Iu UP PDU Type.

The first RAB Sub-flow Combination proposed in the list of RAB Sub-Flow Combinations corresponds to the maximum bit rate allowed to be used when starting the communication phase i.e. until the first RATE CONTROL control frame occurs. The RAB Sub-flow Combinations for rates below the guaranteed bit rate as specified in the RAB parameters (indicated to the Iu-UP at the RNC) shall not be used as the first RAB Sub-flow Combination in the proposed list of RAB Sub-Flow Combinations.

Any RAB Sub-Flow Combination of the set that is initialised shall be supported by the two Iu UP termination points and may optionally be used by the sender (except for the first in the list that shall be used when starting). In particular, the use by the sender of the RFC "NO_DATA" is optional even when it is included in the Initialisation procedure.

Conversely, any RAB Sub-Flow Combination that is not part of the initialised set shall not be used even if supported. In particular, the two Iu UP termination points shall be capable of operating without the use of the RFC "NO_DATA".

The complete set of information is framed by the Iu UP Frame Handler function and transferred in an Iu UP INITIALISATION control frame. If needed, the INITIALISATION control frame CRC is calculated and set accordingly in the respective frame field.

A supervision timer T_{INT} is started after sending the Iu UP INITIALISATION control frame. This timer supervises the reception of the initialisation acknowledgement frame.

Upon reception of a frame indicating that an Initialisation procedure is active in the peer Iu UP entity, the Iu UP protocol layer forwards the whole protocol information contained in the INITIALISATION control frame to the upper layers. It also stores the RAB sub-Flow Combination set (and thus replaces a possible previous set) in order to control during the transfer of user data, that the Iu UP payload is correctly formatted (e.g. RFCI matches the expected Iu UP frame payload total length). The peer Iu UP entity receiving the INITIALISATION control frame shall choose a version that it supports, which is among a set of required versions and for which the peer Iu UP entity has enough initialisation information.

If the INITIALISATION control frame is correctly formatted and treated by the receiving Iu UP protocol layer, this latter sends an initialisation acknowledgement frame using the version of the Iu UP Mode that is chosen.

Upon reception of an initialisation acknowledgement frame, the Iu UP protocol layer in the SRNC stops the supervision timer T_{INIT} .

If the Initialisation procedure requires that several frames are to be sent, each frame shall be acknowledged individually (i.e. any frame to be sent shall wait for the acknowledgement of the previous sent frame to be received before being sent). The supervision timer shall be used individually for each frame being sent.

The successful operation of the Initialisation procedure may require that one or several chained frames are positively acknowledged. The number of INITIALISATION control frames in such a chain shall not exceed 4. Each chained frame shall be positively acknowledged before the one with the next frame number can be sent.

The *Frame Number* IE of an INITIALISATION control frame shall always be set to "0" when the chain has only one frame. When several INITIALISATION control frames are used in a chain the *Frame Number* IE shall be set to "0" for the first one and incremented by one in the sending direction for each new frame in the chain. The positive acknowledgement or negative acknowledgement shall carry the frame number of the frame being acknowledged.

Upon reception of an INITIALISATION NEGATIVE ACKNOWLEDGEMENT control frame, an erroneous acknowledgement or at timer T_{INIT} expiry, the Iu UP protocol entity controlling the Initialisation procedure shall reset and restart the T_{INIT} supervision timer and repeat one INITIALISATION control frame with the same frame number. The repetition shall be performed up to N_{INIT} times, N_{INIT} being chosen by the operator (default $N_{INIT} = 3$). The N_{INIT} (maximum number of allowed repetition) is the aggregate count for each frame in the chain and is restart each time a frame is positively acknowledged.

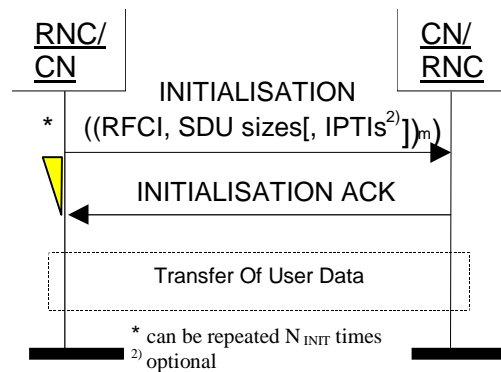

Figure 9: Successful Initialisation of Iu UP for m RFCIs

6.5.2.2 Unsuccessful operation

If the INITIALISATION control frame is incorrectly formatted and cannot be correctly treated by the receiving Iu UP protocol layer, this latter sends an INITIALISATION NEGATIVE ACKNOWLEDGEMENT control frame.

If the receiver does not support the Iu UP Mode version for the Initialisation procedure, it shall send a negative acknowledgement using the highest version it supports among the versions proposed by the sender. If none of the proposed versions are supported, the receiver shall respond with a negative acknowledgement using the highest version it supports.

After N_{INIT} successive negative acknowledgment, erroneous acknowledgment or T_{INIT} expiry for INITIALISATION control frames having the same frame number, the Initialisation procedure is unsuccessfully terminated and the Iu UP protocol layers in RNC take appropriate local actions.

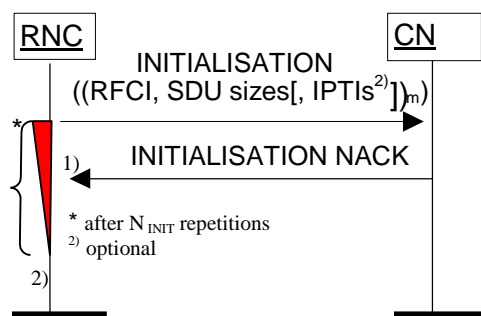

Figure 10: Unsuccessful initialisation of Iu UP: 1) N_{INIT} negative acknowledgement or 2) N_{INIT} expiries of timer T_{INIT}

6.5.3 Iu Rate Control procedure

6.5.3.1 Successful operation

The purpose of the Iu Rate Control procedure is to signal to the peer Iu UP protocol layer the maximum rate over Iu in the reverse direction of the sent RATE CONTROL control frame.

The Rate Control procedure over Iu UP is normally controlled by the entity controlling the rate control over UTRAN i.e. the SRNC. The Iu Rate Control procedure is invoked whenever the SRNC decides that the maximum rate permitted downlink over Iu shall be modified, or when a RATE CONTROL control frame is received from the CN. Within the context of TrFO the SRNC may also receive RATE CONTROL control frames from the TrFO partner.

The rates that can be controlled by the SRNC are all the rates that are defined by the Iu-Initialisation procedure and which are above the guaranteed bitrate specified in the RAB parameters (indicated to the Iu UP at the RNC). Rates below or equal to the guaranteed bitrate, e.g. the lowest speech rate or the SID frames, cannot be controlled (i.e. cannot be forbidden) by the SRNC ([exceptionally, in case of version 1 any of the initialised rates equal to or above the guaranteed bitrate can be controlled](#)).

The procedure can be signalled at any time when Transfer of User Data procedure is not suspended by another Procedure Control function. When the user plane was initiated due to SRNS relocation reasons no rate control shall be signalled before the reception of the relocation execution trigger (see [3]). At the reception of the relocation execution trigger the RNC shall start the Iu Rate Control procedure. This enables both TrFO partners to exchange current maximum rates and proceed user data transport based on latest rate decisions.

The Procedure Control function upon request of upper layer prepares the RATE CONTROL control frame payload containing the maximum rate of the reverse direction of the RATE CONTROL control frame. To align the Iu Rate Control procedure with version 1 of the Iu UP protocol the permitted maximum rate is given as a set of RFCI indicators, that shall contain the maximum rate and all rates below the maximum rate, i.e. all rate controllable and non rate controllable rates. In the context of TrFO and TFO the Iu Rate Control procedure may also be controlled by a remote peer.

The Frame Handler function calculates the frame CRC, formats the frame header into the appropriate PDU Type and sends the Iu UP frame PDU to the lower layers for transfer across the Iu interface.

A supervision timer T_{RC} is started after sending the Iu UP RATE CONTROL control frame. This timer supervises the reception of the rate control acknowledgement frame. Upon reception of a rate control acknowledgement frame, the Iu UP protocol layer in the SRNC stops the supervision timer T_{RC} .

Upon reception of a RATE CONTROL control frame, the Iu UP protocol layer checks the consistency of the Iu UP frame as follows:

- The Frame Handler function checks the consistency of the frame header and associated CRC. If correct, the Frame Handler function passes Procedure Control part to the procedure control functions;

- The Procedure Control functions check that all RFCIs in the initial RFCI set are indicated as either allowed or barred. If the whole rate control information is correct, the Procedure Control functions passes the rate control information to the NAS Data Streams specific functions;
- The NAS Data Streams specific functions forward to the upper layers the complete protocol data in a Iu-UP-Status indication primitive;
- Upon reception of the Iu-UP-Status request primitive, the Procedure Control functions shall acknowledge the RATE CONTROL control frame by including it's own maximum rate control information.

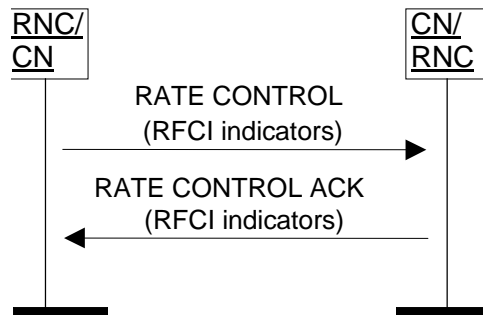

Figure 11: Successful Rate Control

Figure 12: Void