

TSG-RAN Meeting #27
Tokyo, Japan, 09-11 March 2005

RP-050115
Agenda item 9.6

Source: TSG-RAN WG2

Title: 25.309 CR to Rel-6 on Enhanced Uplink

Spec	CR	Rev	Phase	Subject	Cat	Version-Current	Version-New	Doc-2nd-Level	Workitem
25.309	005	-	Rel-6	Introduction of Details for the scheduling operation, non-scheduled transmission and E-TFC selection	B	6.1.0	6.2.0	R2-050716	EUDCH-L23

CHANGE REQUEST

25.309 CR 005 rev - Current version: 6.1.0

For **HELP** on using this form, see bottom of this page or look at the pop-up text over the ☞ symbols.

Proposed change affects: | UICC apps ME Radio Access Network Core Network

Title:	☞ Introduction of details for the scheduling operation, non-scheduled transmission and E-TFC selection		
Source:	☞ RAN WG2		
Work item code:	☞ EDCH-L23	Date:	☞ 02/03/2005
Category:	☞ B	Release:	☞ REL-6
	Use <u>one</u> of the following categories:		Use <u>one</u> of the following releases:
	F (correction)		2 (GSM Phase 2)
	A (corresponds to a correction in an earlier release)		R96 (Release 1996)
	B (addition of feature),		R97 (Release 1997)
	C (functional modification of feature)		R98 (Release 1998)
	D (editorial modification)		R99 (Release 1999)
	Detailed explanations of the above categories can be found in 3GPP TR 21.900 .		Rel-4 (Release 4)
			Rel-5 (Release 5)
			Rel-6 (Release 6)

Reason for change:	☞
Summary of change:	☞ Introduction of details for the scheduling operation, non-scheduled transmission and E-TFC selection agreed at RAN2#45bis and RAN2#46.
Consequences if not approved:	☞

Clauses affected:	☞								
Other specs affected:	<table border="1" style="display: inline-table; border-collapse: collapse; text-align: center;"> <tr> <td style="width: 20px;">Y</td> <td style="width: 20px;">N</td> </tr> <tr> <td style="width: 20px;"> </td> <td style="width: 20px;"> </td> </tr> <tr> <td style="width: 20px;"> </td> <td style="width: 20px;"> </td> </tr> </table>	Y	N					Other core specifications	☞
Y	N								
		Test specifications							
		O&M Specifications							
Other comments:	☞								

How to create CRs using this form:

Comprehensive information and tips about how to create CRs can be found at <http://www.3gpp.org/specs/CR.htm>. Below is a brief summary:

- 1) Fill out the above form. The symbols above marked ☞ contain pop-up help information about the field that they are closest to.
- 2) Obtain the latest version for the release of the specification to which the change is proposed. Use the MS Word "revision marks" feature (also known as "track changes") when making the changes. All 3GPP specifications can be downloaded from the 3GPP server under <ftp://ftp.3gpp.org/specs/>. For the latest version, look for the directory name with the latest date e.g. 2001-03 contains the specifications resulting from the March 2001 TSG meetings.
- 3) With "track changes" disabled, paste the entire CR form (use CTRL-A to select it) into the specification just in front of the clause containing the first piece of changed text. Delete those parts of the specification which are not relevant to the change request.

3GPP TS 25.309 V6.24.0 (2005-032004-12)

Technical Specification

**3rd Generation Partnership Project;
Technical Specification Group Radio Access Network;
FDD Enhanced Uplink;
Overall description;
Stage 2
(Release 6)**



The present document has been developed within the 3rd Generation Partnership Project (3GPPTM) and may be further elaborated for the purposes of 3GPP.

The present document has not been subject to any approval process by the 3GPP Organizational Partners and shall not be implemented. This Specification is provided for future development work within 3GPP only. The Organizational Partners accept no liability for any use of this Specification. Specifications and reports for implementation of the 3GPPTM system should be obtained via the 3GPP Organizational Partners' Publications Offices.

Keywords

UMTS, data, stage 2

3GPP

Postal address

3GPP support office address

650 Route des Lucioles – Sophia Antipolis
Valbonne - France
Tel.: +33 4 92 94 42 00 Fax: +33 4 93 65 47 16

Internet

<http://www.3gpp.org>

Copyright Notification

No part may be reproduced except as authorized by written permission.
The copyright and the foregoing restriction extend to reproduction in all media.

© 2004, 3GPP Organizational Partners (ARIB, ATIS, CCSA, ETSI, TTA, TTC).
All rights reserved.

Contents

Foreword.....	9
1 Scope.....	10
2 References.....	10
3 Definitions and abbreviations.....	10
3.1 Definitions.....	10
3.2 Abbreviations.....	10
4 Background and Introduction.....	11
5 Requirements.....	11
6 Overall architecture of enhanced uplink DCH.....	12
6.1 Protocol architecture.....	12
6.2 Transport channel attributes.....	12
6.3 Basic physical structure.....	13
6.3.1 UL Physical layer model.....	13
6.3.2 DL Physical layer model.....	13
7 MAC architecture.....	14
7.1 General Principle.....	14
7.1.1 MAC multiplexing.....	14
7.1.2 Reordering entity.....	15
7.2 MAC architecture – UE side.....	15
7.2.1 Overall architecture.....	15
7.2.2 Details of MAC-d.....	18
7.2.3 Details of MAC-c/sh.....	19
7.2.4 Details of MAC-hs.....	19
7.2.5 Details of MAC-es/MAC-e.....	20
7.3 MAC architecture – UTRAN side.....	20
7.3.1 Overall architecture.....	20
7.3.2 Details of MAC-d.....	24
7.3.3 Details of MAC-c/sh.....	25
7.3.4 Details of MAC-hs.....	25
7.3.5 Details of MAC-es.....	26
7.3.6 Details of MAC-e.....	26
8 HARQ protocol.....	27
8.1 General Principle.....	27
8.2 Error handling.....	28
8.3 Signalling.....	28
8.3.1 Uplink.....	28
8.3.2 Downlink.....	28
9 Node B controlled scheduling.....	29
9.1 General Principle.....	29
9.2 UE scheduling operation.....	30
9.2.1 Grants from the Serving RLS.....	30
9.2.2 Grants from the Non-serving RLS.....	32
9.2.3 Reception of Grants from both the Serving and Non-serving RLS.....	32
9.3 Signalling.....	32
9.3.1 Uplink.....	32
9.3.2 Downlink.....	34
10 Non-scheduled transmissions.....	34
11 QoS control.....	35
11.1 General Principle.....	35
11.1.1 QoS configuration principles.....	35

11.2	TFC and E-TFC selection	36
11.3	Setting of Power offset attributes of MAC-d flows	37
12	Signalling parameters	37
12.1	Uplink signalling parameters	37
12.1.1	Transport block size	37
12.2	Downlink signalling parameters	37
13	Mobility procedures	38
1	Scope	6
2	References	6
3	Definitions and abbreviations	6
3.1	Definitions	6
3.2	Abbreviations	6
4	Background and Introduction	7
5	Requirements	7
6	Overall architecture of enhanced uplink DCH	8
6.1	Protocol architecture	8
6.2	Transport channel attributes	8
6.3	Basic physical structure	9
6.3.1	UL Physical layer model	9
6.3.2	DL Physical layer model	9
7	MAC architecture	10
7.1	General Principle	10
7.1.1	MAC multiplexing	10
7.1.2	Reordering entity	11
7.2	MAC architecture – UE side	11
7.2.1	Overall architecture	11
7.2.2	Details of MAC d	12
7.2.3	Details of MAC e/sh	13
7.2.4	Details of MAC hs	13
7.2.5	Details of MAC es/MAC e	13
7.3	MAC architecture – UTRAN side	14
7.3.1	Overall architecture	14
7.3.2	Details of MAC d	16
7.3.3	Details of MAC e/sh	17
7.3.4	Details of MAC hs	17
7.3.5	Details of MAC es	17
7.3.6	Details of MAC e	18
8	HARQ protocol	19
8.1	General Principle	19
8.2	Error handling	20

8.3	Signalling	20
8.3.1	Uplink	20
8.3.2	Downlink	20
9	Node B controlled scheduling	20
9.1	General Principle	20
9.2	UE scheduling operation	21
9.2.1	Grants from the Serving RLS	21
9.2.2	Grants from the Non-serving RLS	22
9.3	Signalling	22
9.3.1	Uplink	22
9.3.2	Downlink	22
10	QoS control	23
10.1	General Principle	23
10.1.1	QoS configuration principles	23
10.2	TFC and E-TFC selection	23
10.3	Setting of Power offset attributes of MAC-d flows	24
11	Signalling parameters	24
11.1	Uplink signalling parameters	24
11.2	Downlink signalling parameters	24
12	Mobility procedures	25
Annex A (informative):	Change history	26

Foreword

This Technical Specification has been produced by the 3rd Generation Partnership Project (3GPP).

The contents of the present document are subject to continuing work within the TSG and may change following formal TSG approval. Should the TSG modify the contents of the present document, it will be re-released by the TSG with an identifying change of release date and an increase in version number as follows:

Version x.y.z

where:

- x the first digit:
 - 1 presented to TSG for information;
 - 2 presented to TSG for approval;
 - 3 or greater indicates TSG approved document under change control.
- y the second digit is incremented for all changes of substance, i.e. technical enhancements, corrections, updates, etc.
- z the third digit is incremented when editorial only changes have been incorporated in the document.

1 Scope

The present document is a technical specification of the overall support of FDD Enhanced Uplink in UTRA.

2 References

The following documents contain provisions which, through reference in this text, constitute provisions of the present document.

- References are either specific (identified by date of publication, edition number, version number, etc.) or non-specific.
- For a specific reference, subsequent revisions do not apply.
- For a non-specific reference, the latest version applies. In the case of a reference to a 3GPP document (including a GSM document), a non-specific reference implicitly refers to the latest version of that document *in the same Release as the present document*.

[1] 3GPP TR 25.896: "Feasibility Study for Enhanced Uplink for UTRA FDD".

[2] 3GPP TR 21.905: "Vocabulary for 3GPP Specifications".

3 Definitions and abbreviations

3.1 Definitions

For the purposes of the present document, the terms and definitions given in 3GPP TR 21.905 [2] and the following apply:

Data Description Indicator (DDI): MAC-e header field used to identify the logical channel, MAC-d flow and the size of the MAC-d PDUs concatenated into a MAC-es PDU.

E-DCH: Enhanced DCH, a new dedicated transport channel type or enhancements to an existing dedicated transport channel type.

E-DCH active set: The set of cells which carry the E-DCH for one UE.

HARQ profile: One HARQ profile consists of a power offset attribute and maximum number of transmissions.

Power offset attribute: Represents the power offset between E-DPDCH(s) and reference E-DPDCH power level for a given E-TFC. This power offset attribute is set to achieve the required QoS in this MAC-d flow when carried alone in a MAC-e PDU and subsequently in the corresponding CCTrCh of E-DCH type. Details on the mapping on Beta factors can be found in RAN WG1 specifications. The reference E-DPDCH power level for a given E-TFC is derived from the beta factor signaled to the UE for a reference E-TFC (see details in subclause ~~11.10~~.1).

Serving E-DCH cell: -Cell from which the UE receives Absolute Grants from the Node-B scheduler. A UE has one Serving E-DCH cell.

Serving E-DCH RLS or Serving RLS: Set of cells which contains at least the Serving E-DCH cell and from which the UE can receive and combine one Relative Grant. The UE has only one Serving E-DCH RLS.

Non-serving E-DCH RLS or Non-serving RLS: Set of cells which does not contain the Serving E-DCH cell and from which the UE can receive and combine one Relative Grant. The UE can have zero, one or several Non-serving E-DCH RLS.

3.2 Abbreviations

For the purposes of the present document, the abbreviations given in 3GPP TR 21.905 [2] and the following apply:

AG	Absolute Grant
E-AGCH	E-DCH Absolute Grant Channel
E-DPCCH	E-DCH Dedicated Physical Control Channel
E-DPDCH	E-DCH Dedicated Physical Data Channel
E-HICH	E-DCH HARQ Acknowledgement Indicator Channel
E-RGCH	E-DCH Relative Grant Channel
E-RNTI	E-DCH Radio Network Temporary Identifier
E-TFC	E-DCH Transport Format Combination
HARQ	Hybrid Automatic Repeat Request
HSDPA	High Speed Downlink Packet Access
RG	Relative Grant
RLS	Radio Link Set
RSN	Retransmission Sequence Number
SG	Serving Grant
TSN	Transmission Sequence Number

4 Background and Introduction

The technical objective of the FDD Enhanced Uplink work item is to improve the performance of uplink dedicated transport channels, i.e. to increase capacity and throughput and reduce delay. This work item is applicable for UTRA FDD only.

Among the techniques considered in [1], the following techniques are part of the work item:

- Node B controlled scheduling: possibility for the Node B to control, within the limits set by the RNC, the set of TFCs from which the UE may choose a suitable TFC,
- Hybrid ARQ: rapid retransmissions of erroneously received data packets between UE and Node B,
- Shorter TTI: possibility of introducing a 2 ms TTI.

5 Requirements

- The Enhanced Uplink feature shall aim at providing significant enhancements in terms of user experience (throughput and delay) and/or capacity. The coverage is an important aspect of the user experience and that it is desirable to allow an operator to provide for consistency of performance across the whole cell area.
- The focus shall be on urban, sub-urban and rural deployment scenarios.
- Full mobility shall be supported, i.e., mobility should be supported for high-speed cases also, but optimisation should be for low-speed to medium-speed scenarios.
- The study shall investigate the possibilities to enhance the uplink performance on the dedicated transport channels in general, with priority to streaming, interactive and background services. Relevant QoS mechanisms shall allow the support of streaming, interactive and background PS services.
- It is highly desirable to keep the Enhanced Uplink as simple as possible. New techniques or group of techniques shall therefore provide significant incremental gain for an acceptable complexity. The value added per feature/technique should be considered in the evaluation. It is also desirable to avoid unnecessary options in the specification of the feature.
- The UE and network complexity shall be minimised for a given level of system performance.
- The impact on current releases in terms of both protocol and hardware perspectives shall be taken into account.
- It shall be possible to introduce the Enhanced Uplink feature in a network which has terminals from Release'99, Release 4 and Release 5. The Enhanced Uplink feature shall enable to achieve significant improvements in overall system performance when operated together with HSDPA. Emphasis shall be given on the potential

impact the new feature may have on the downlink capacity. Likewise it shall be possible to deploy the Enhanced Uplink feature without any dependency on the deployment of the HSDPA feature. However, a terminal supporting the Enhanced Uplink feature must support HSDPA.

6 Overall architecture of enhanced uplink DCH

6.1 Protocol architecture

The following modifications to the existing nodes are needed to support enhanced uplink DCH:

UE

A new MAC entity (MAC-es/MAC-e) is added in the UE located below MAC-d. MAC-es/MAC-e in the UE handles HARQ retransmissions, scheduling and MAC-e multiplexing, E-DCH TFC selection.

Node B

A new MAC entity (MAC-e) is added in Node B which handles HARQ retransmissions, scheduling and MAC-e demultiplexing.

S-RNC

A new MAC entity (MAC-es) is added in the SRNC to provide in-sequence delivery (reordering) and to handle combining of data from different Node Bs in case of soft handover.

The resulting protocol architecture is shown in Figure 6.1-1:

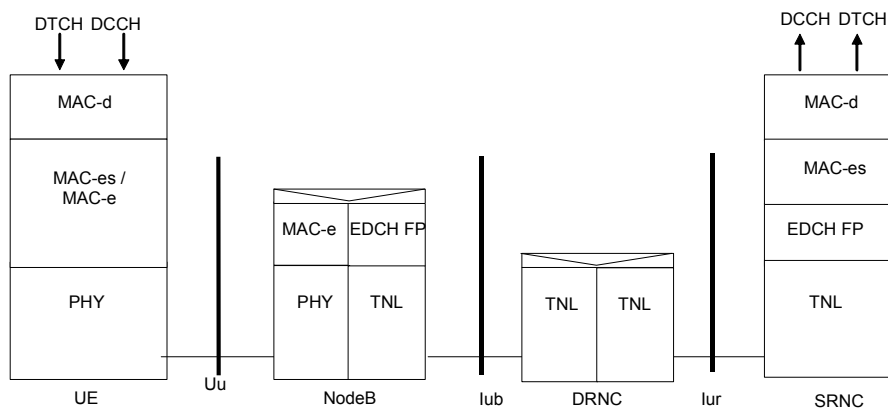

Figure 6.1-1: Protocol Architecture of E-DCH

The need for an E-DCH FP in the DRNC has to be discussed (this is under the scope of RAN WG3).

6.2 Transport channel attributes

The E-DCH transport channel has the following characteristics:

- E-DCH and DCH are using separate CCTrCHs
- There is only one CCTrCH of E-DCH type per UE;

- There is only one E-DCH per CCTrCH of E-DCH type;
- There is only one transport block per TTI;
- Both 2 ms TTI and 10 ms TTI are supported by the E-DCH. The support of 10 ms TTI is mandatory for all UEs. The support of the 2 ms TTI by the UEs is only FFS (always optional or mandatory for certain high UE categories);
- For all UE categories, the uplink DCH CCTrCH data rate is limited to 64kbps when E-DCH is configured for the radio link.

6.3 Basic physical structure

6.3.1 UL Physical layer model

E-DCH model with DCH and HS-DSCH

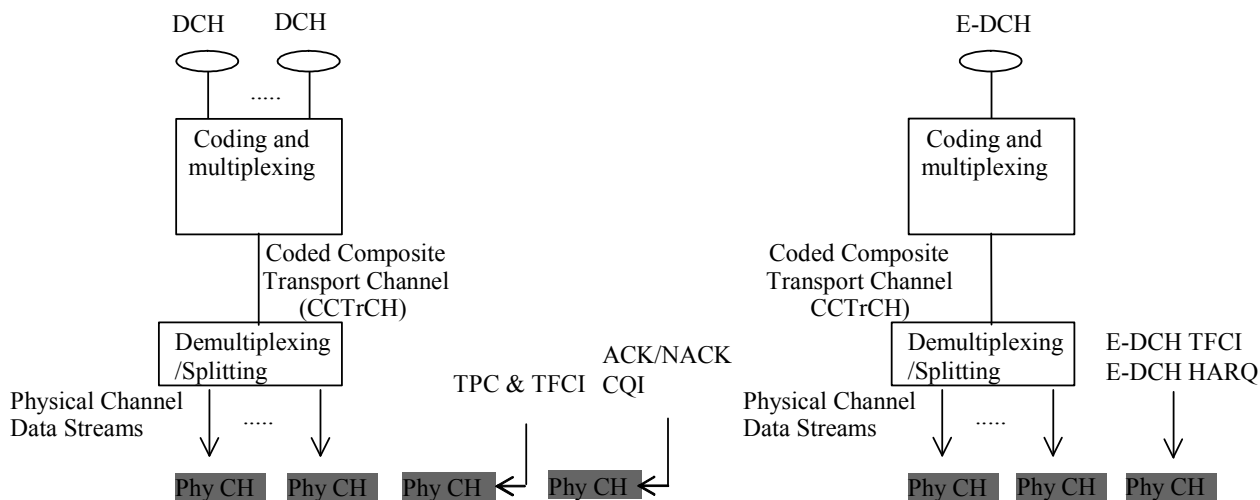

Figure 6.3.1-1: Model of the UE's Uplink physical layer

There is only one E-DCH per CCTrCh of E-DCH type.

For both 2 ms and 10 ms TTI, the information carried on the E-DPCCH consists of 10 bits in total: the E-TFI (7 bits) and the RSN (2 bits). And it is FFS, whether the last) and the 'happy' bit should be used for a scheduling request or something else (see in subclause 9.3.1.2).

The E-DPCCH is sent with a power offset relative to the DPCCH. The power offset is signalled by RRC.

6.3.2 DL Physical layer model

E-DCH model with DCH and HS-DSCH

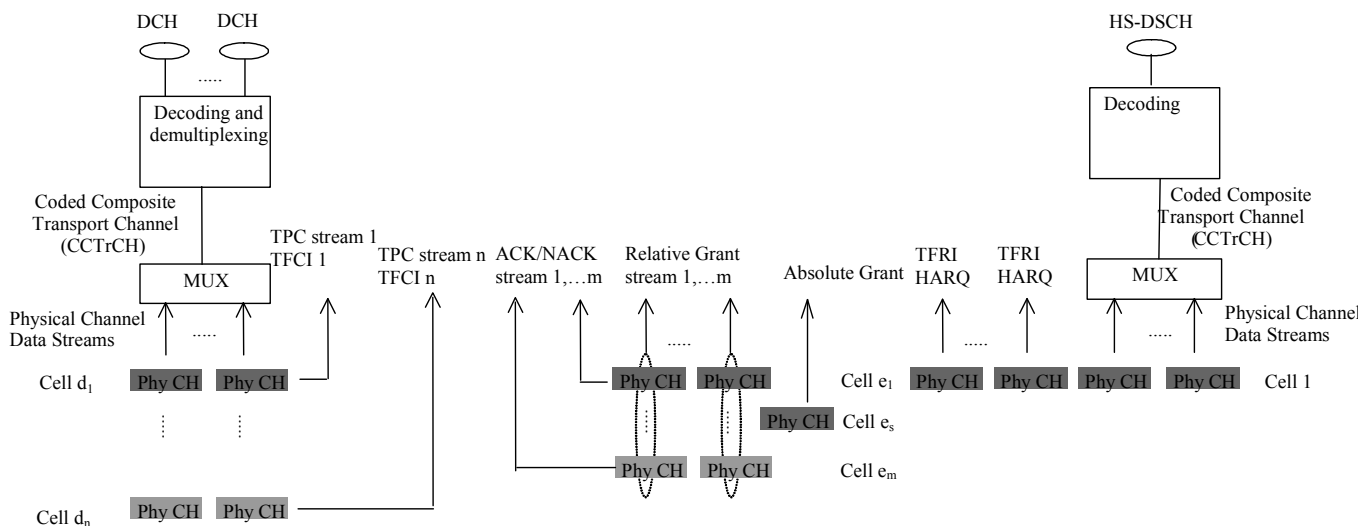

Figure 6.3.2-1: Model of the UE's Downlink physical layer. HS-DSCH serving cell is cell 1 in this figure

The DPCCH active set contains cells d_1, \dots, d_n .

The E-DCH active set can be identical or a subset of the DCH active set. The E-DCH active set is decided by the SRNC.

The E-DCH ACK/NACKs are transmitted by each cell of the E-DCH active set on a physical channel called E-HICH. The E-HICHs of the cells belonging to the same RLS (same MAC-e entity i.e. same Node B) shall have the same content and modulation and be combined by the UE.

NOTE: The set of cells transmitting identical ACK/NACK information is the same as the set of cells sending identical TPC bits (excluding the cells which are not in the E-DCH active set).

The E-DCH Absolute Grant is transmitted by a single cell, the Serving E-DCH cell (Cell e_s on figure 6.3.2-1) on a physical channel called E-AGCH.

NOTE: The relationship between the Serving E-DCH cell and the HS-DSCH Serving cell is FFS. The RRC signalling will however be independent and allow for both to be separate.

The E-DCH Relative Grants can be transmitted by each cell of the E-DCH active set on a physical channel called E-RGCH. The E-RGCHs of the cells belonging to the same RLS shall have the same content and be combined by the UE. These RLS are signalled from the SRNC to the UE in RRC: optionally (see subclause 9.2.1 where E-RGCH physical channels are allocated or not) one Serving E-DCH RLS (containing the Serving E-DCH cell) and optionally one or several Non-serving E-DCH RLS.

The ACK/NACKs received from UTRAN after combining (see Note above), the Absolute Grant information received from UTRAN (from the Serving E-DCH cell), and the Relative Grants received from UTRAN after combining (optionally one from the Serving E-DCH RLS, and optionally one from each Non-serving RLS(s)), are all sent to MAC by L1.

7 MAC architecture

7.1 General Principle

7.1.1 MAC multiplexing

The E-DCH MAC multiplexing has the following characteristics:

- Logical channel MAC-d multiplexing is supported at MAC-e level;
- Multiple MAC-d flows can be configured for one UE;
- The multiplexing of different MAC-d flows within the same MAC-e PDU is supported. But not all the combinations may be allowed for one UE. The allowed combinations are under the control of the SRNC. (See in clause 11.40)
- There can be up to 8 MAC-d flows for a UE.
- Up to 16 logical channels can be multiplexed on an E-DCH transport channel

7.1.2 Reordering entity

The re-ordering entity is part of a separate MAC sub-layer, MAC-es, in the SRNC. Data coming from different MAC-d flows are reordered in different reordering queues. There is one reordering queue per logical channel.

The reordering is based on a specific TSN included in the MAC-es PDU and on Node-B tagging with a (CFN, subframe number). For each MAC-es PDU, the SRNC receives the TSN originating from the UE, as well as the (CFN, subframe number) originating from the Node-B to perform the re-ordering. Additional mechanisms (e.g. timer-based and/or window-based) are up to SRNC implementation and will not be standardised. Furthermore, the reordering entity detects and removes duplicated received MAC-es PDUs.

7.2 MAC architecture – UE side

7.2.1 Overall architecture

The overall UE MAC architecture, which is shown in Figure 7.2.1-1, includes a new MAC-es/MAC-e entity which controls access to the E-DCH. A new connection from MAC-d to MAC-es/MAC-e is added to the architecture, as well as a connection between MAC-es/MAC-e and the MAC Control SAP.

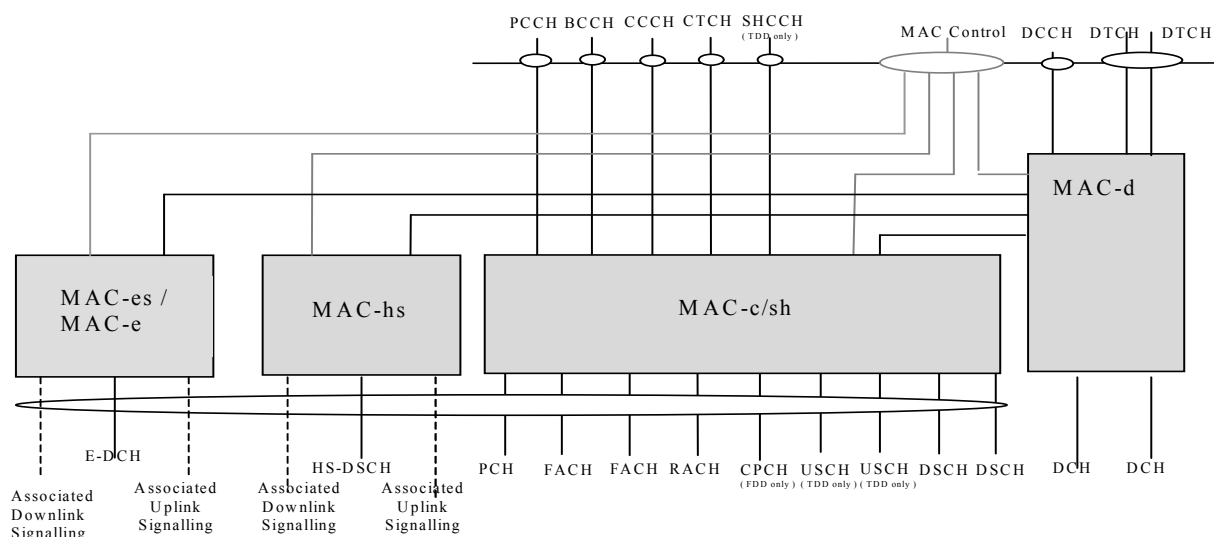
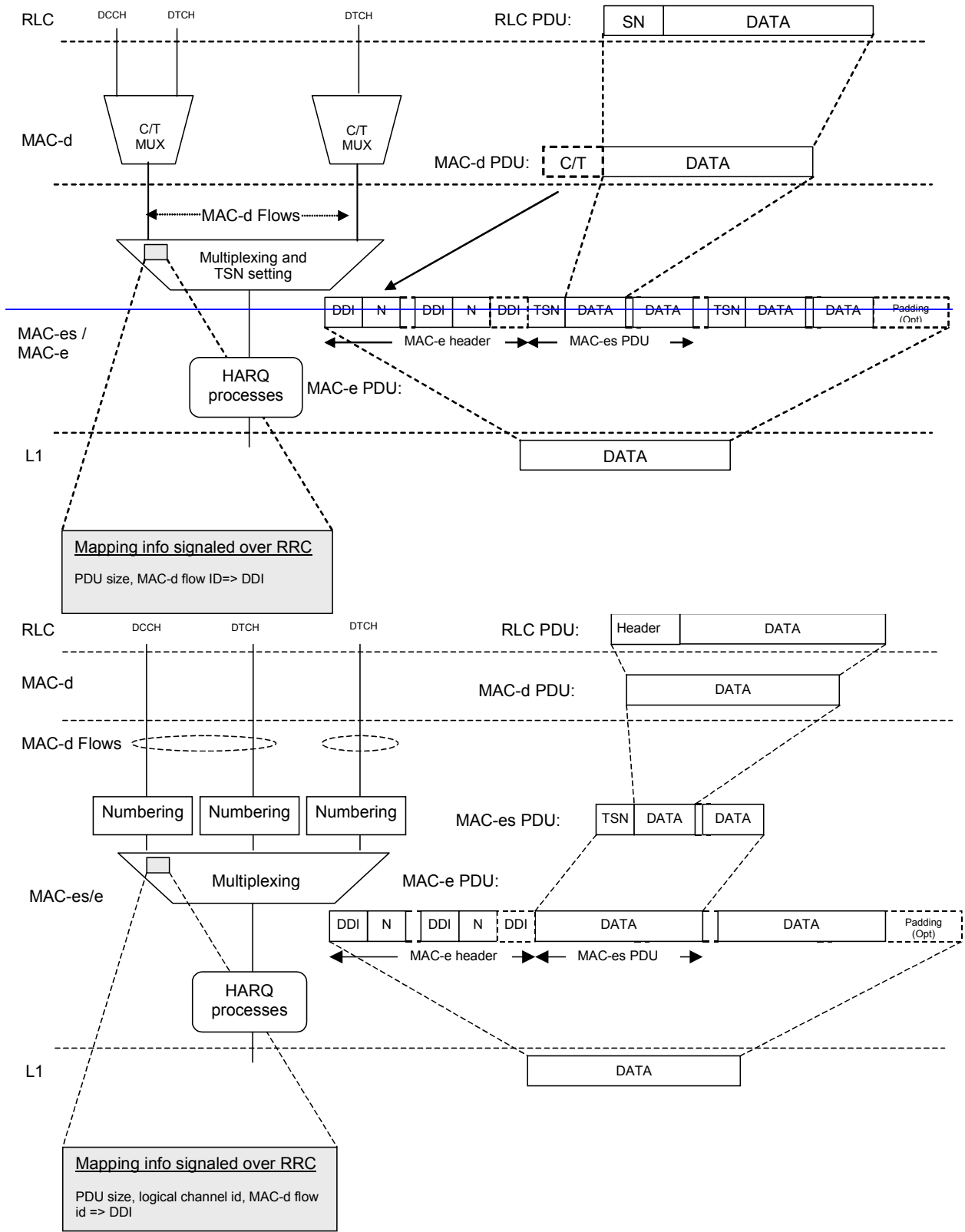

Figure 7.2.1-1: UE side MAC architecture

As shown in Figure 7.2.1-2, a RLC PDU enters MAC-d on a logical channel. The MAC-d C/T multiplexing is bypassed. RLC PDUs from one or more logical channels are C/T multiplexed on a MAC-e PDU. In the MAC-e header, the DDI (Data Description Indicator) field (6 bits) identifies logical channel, MAC-d flow and MAC-d PDU size. A mapping table is signalled over RRC, to allow the UE to set DDI values. The N field (fixed size of 6 bits) indicates the

number of consecutive MAC-d PDUs corresponding to the same DDI value. A special value of the DDI field indicates that no more data is contained in the remaining part of the MAC-e PDU. The TSN field (6 bits) provides the transmission sequence number on the E-DCH. The MAC-e PDU is forwarded to a Hybrid ARQ entity, which then forwards the MAC-e PDU to layer 1 for transmission in one TTI.

~~NOTE: It is possible to bypass the MAC-d C/T multiplexing. The DDI field is then directly used to identify the logical channel(s) mapped on the same MAC-d flow. This is up to UE implementation.~~



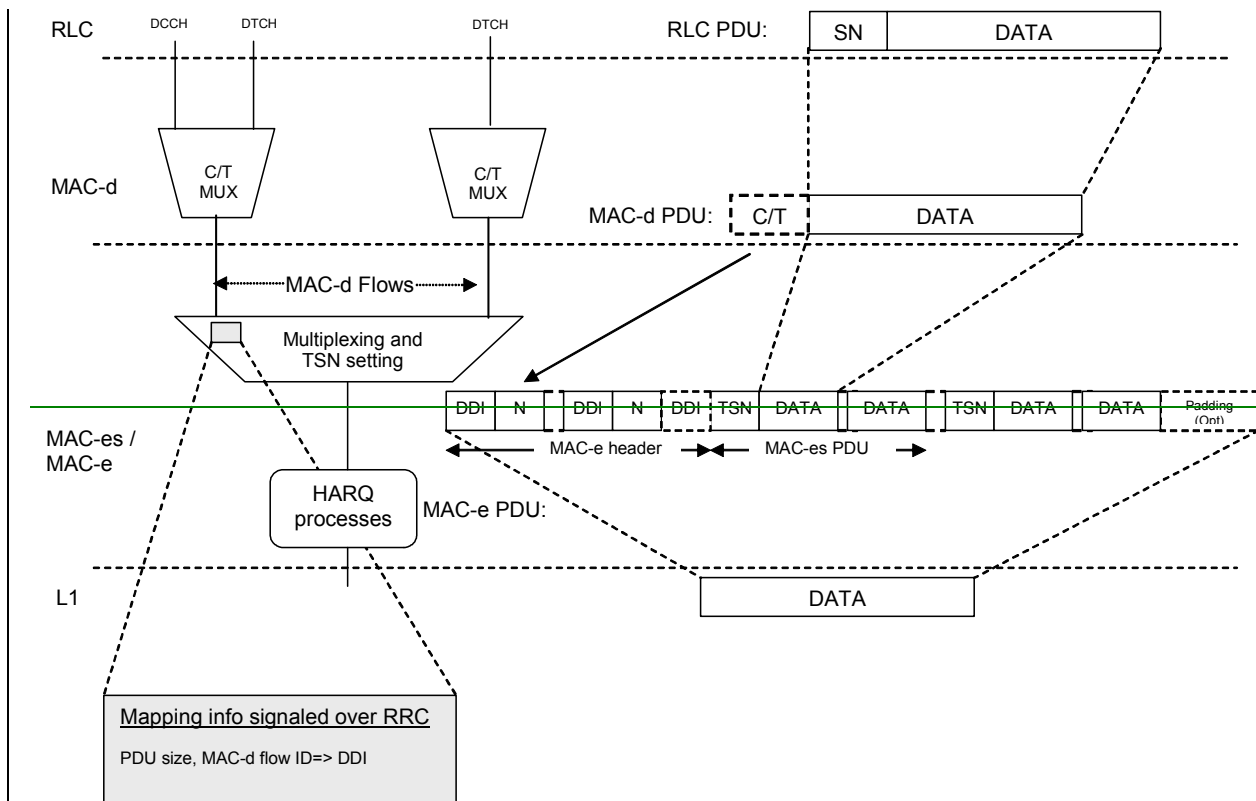

Figure 7.2.1-2: Simplified architecture showing MAC inter-working in UE. The left part shows the functional split while the right part shows PDU construction.

7.2.2 Details of MAC-d

For support of E-DCH a new connection to MAC-es is added.

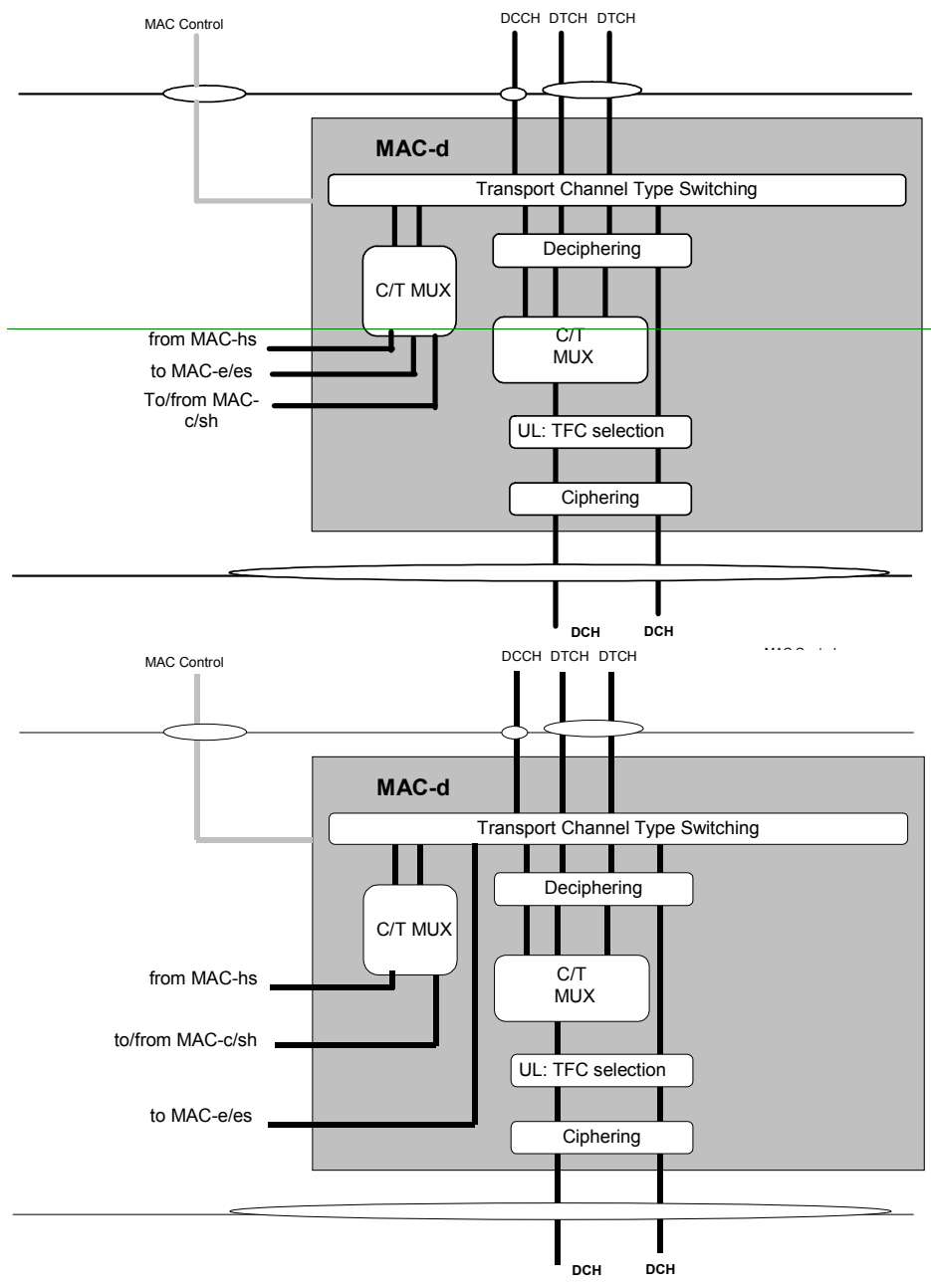

Figure 7.2.2-1: UE side MAC architecture/ MAC-d details

7.2.3 Details of MAC-c/sh

The support of E-DCH implies no change to the UE MAC-c/sh entity.

7.2.4 Details of MAC-hs

The support of E-DCH implies no change to the UE MAC-hs entity.

7.2.5 Details of MAC-es/MAC-e

The MAC-es/e handles the E-DCH specific functions. The split between MAC-e and MAC-es in the UE is not detailed. In the model below the MAC-e/es comprises the following entities:

- HARQ:

The HARQ entity is responsible for handling the MAC functions relating to the HARQ protocol. It is responsible for storing MAC-e payloads and re-transmitting them. The detailed configuration of the hybrid ARQ protocol is provided by RRC over the MAC-Control SAP. The HARQ entity provides the E-TFC, the retransmission sequence number (RSN), and the power offset to be used by L1. Redundancy version (RV) of the HARQ transmission is derived by L1 from RSN, CFN and in case of 2 ms TTI from the sub-frame number. RRC signalling can also configure the HARQ entity to use RV=0 for every transmission.
- Multiplexing:

The multiplexing entity is responsible for concatenating multiple MAC-d PDUs into MAC-es PDUs, and to multiplex one or multiple MAC-es PDUs into a single MAC-e PDU, to be transmitted at the next TTI, and as instructed by the E-TFC selection function. It is also responsible for managing and setting the TSN per logical channel for each MAC-es PDU.
- E-TFC selection:

This entity is responsible for E-TFC selection according to the scheduling information (Relative Grants and Absolute Grants) received from UTRAN via L1, and for arbitration among the different flows mapped on the E-DCH. The detailed configuration of the E-TFC entity is provided by RRC over the MAC-Control SAP. The E-TFC selection function controls the multiplexing function.

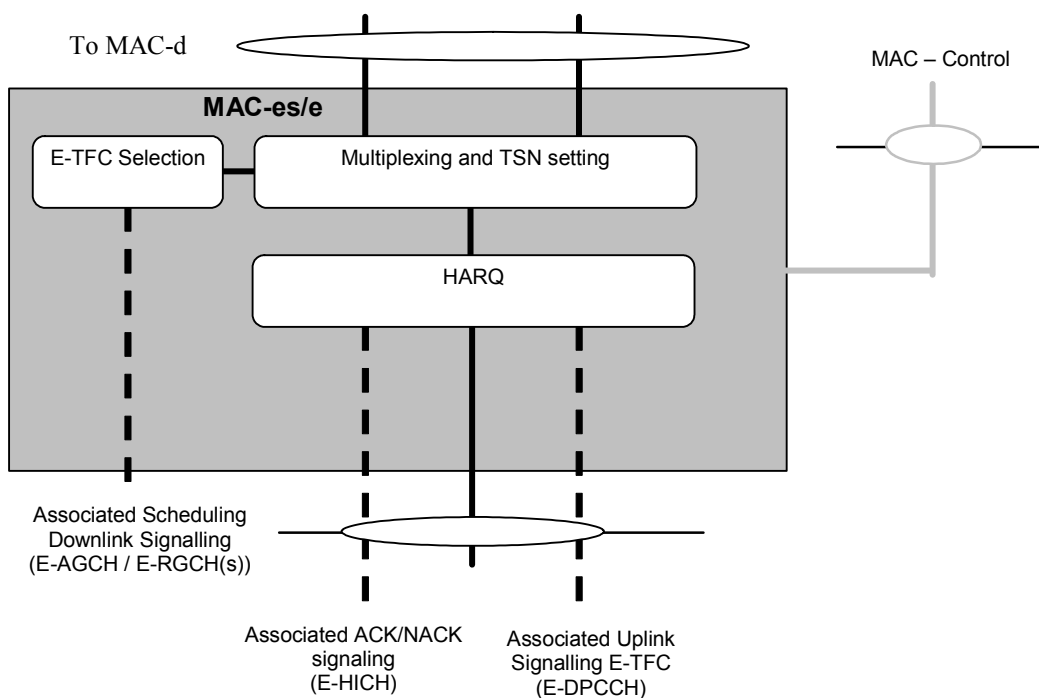

Figure 7.2.5-1: UE side MAC architecture / MAC-es/e details

7.3 MAC architecture – UTRAN side

7.3.1 Overall architecture

The overall UTRAN MAC architecture, which is shown in Figure 7.3.1-1, includes a new MAC-e entity and a new MAC-es entity. For each UE that uses E-DCH, one MAC-e entity per Node-B and one MAC-es entity in the SRNC are configured. MAC-e, located in the Node B, controls access to the E-DCH and is connected to MAC-es, located in the SRNC. MAC-es is further connected to MAC-d. For control information, new connections are defined between MAC-e and a MAC Control SAP in the Node B, and between MAC-es and the MAC Control SAP in the SRNC.

There is one Iub transport bearer per MAC-d flow (i.e. MAC-es PDUs carrying MAC-d PDUs from the same MAC-d flow).

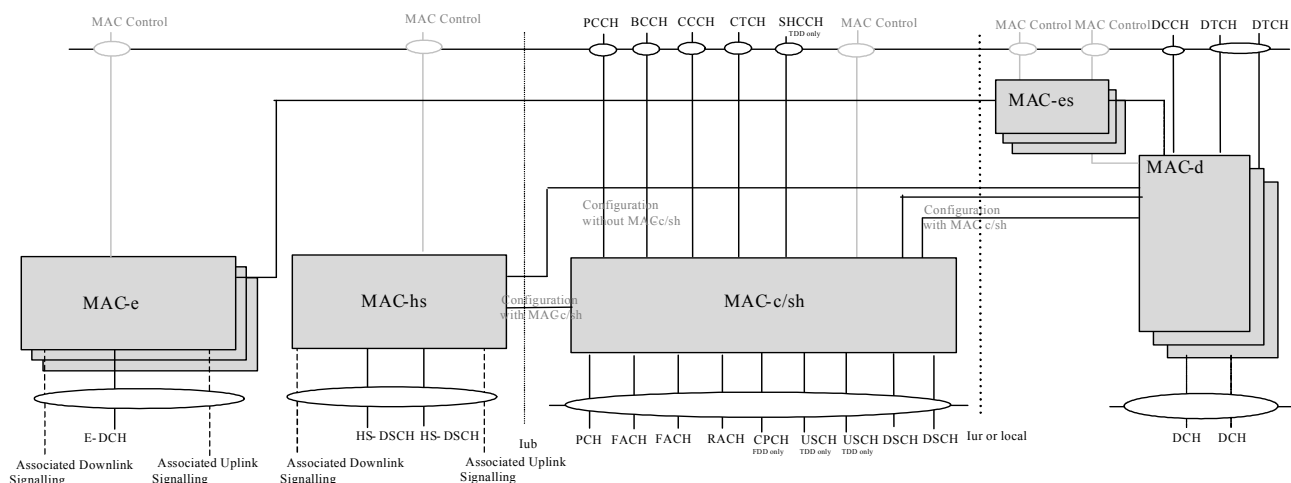
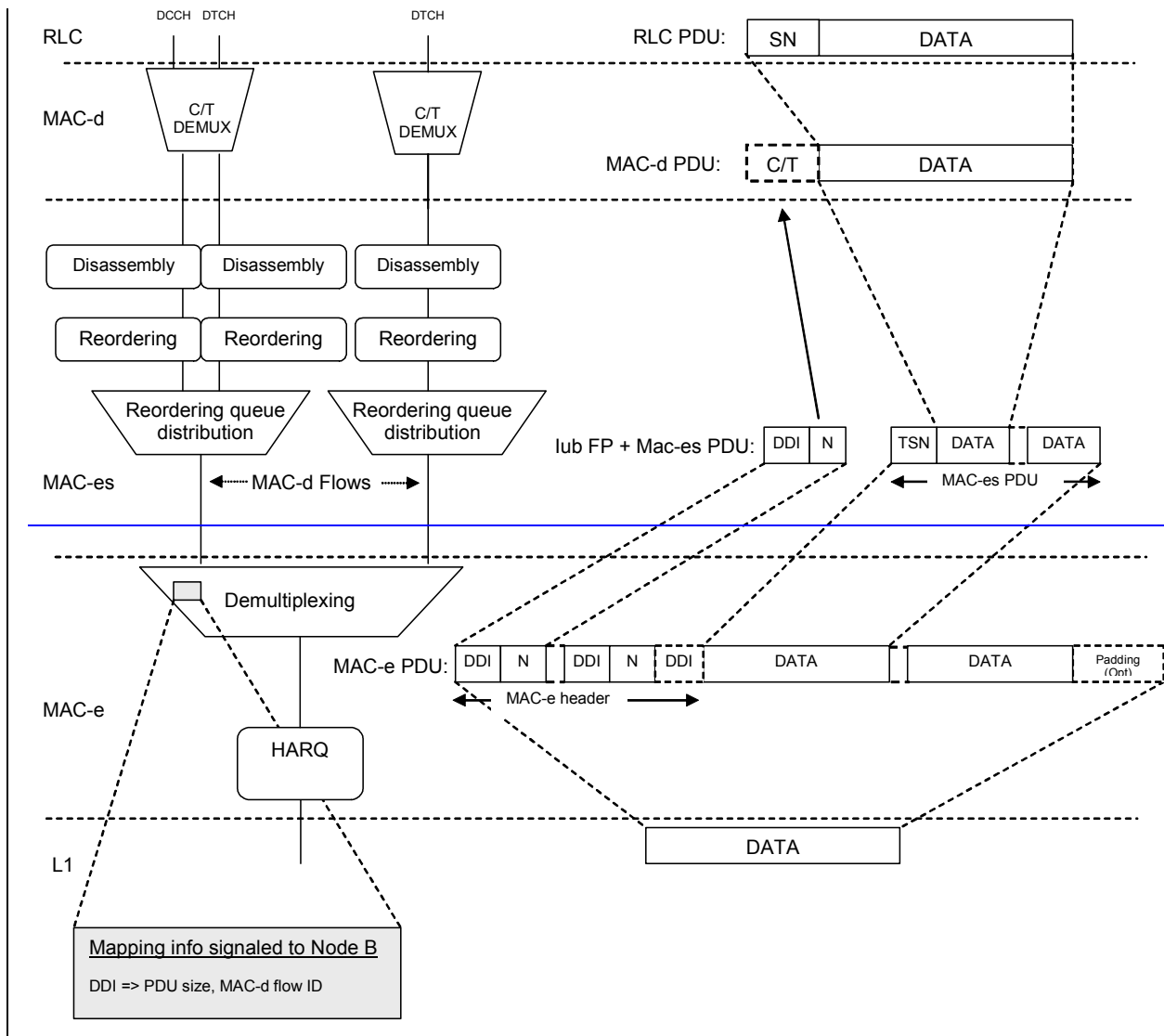
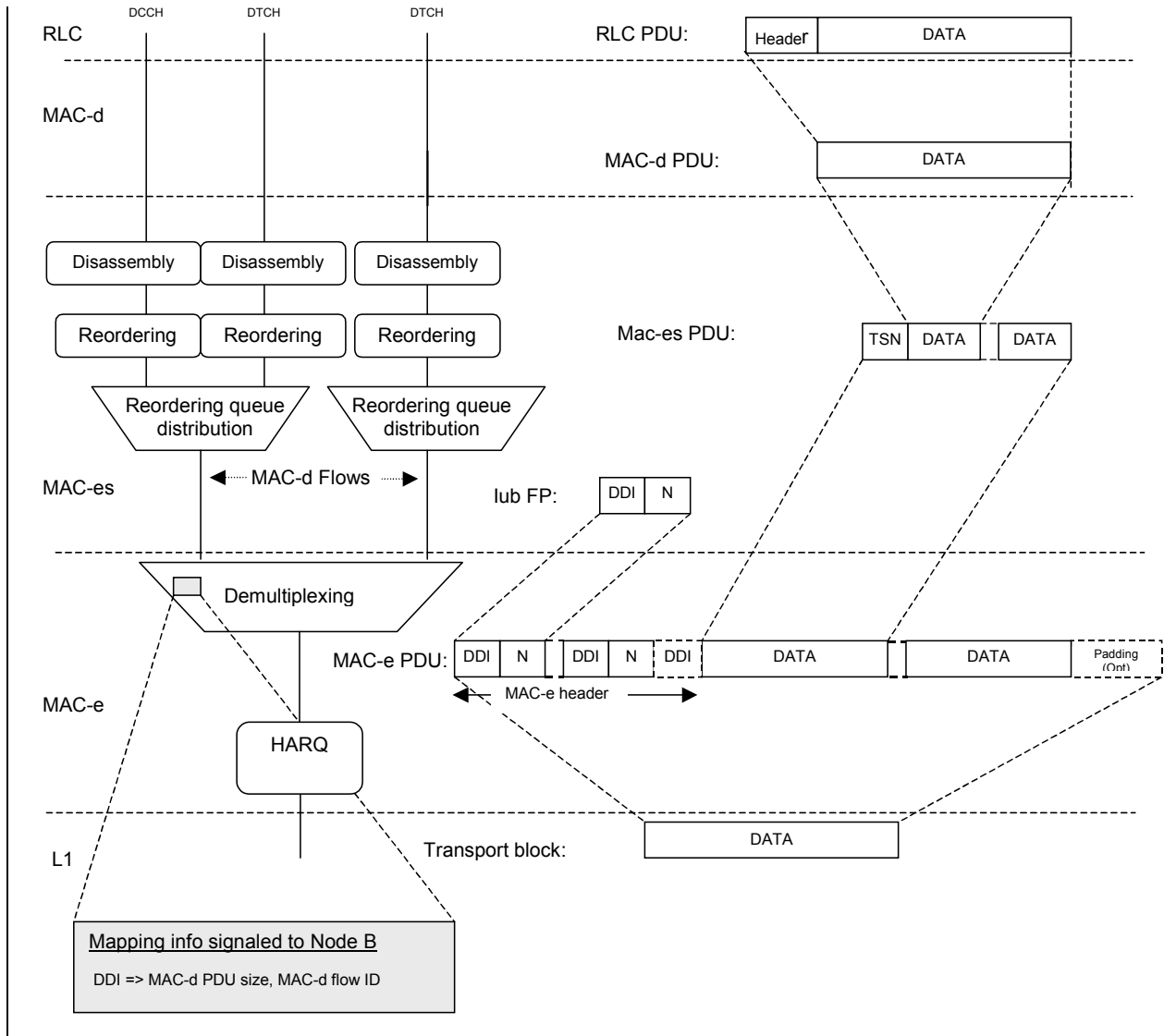

Figure 7.3.1-1: UTRAN side MAC architecture (SHO not shown)

As shown in Figure 7.3.1-2, a MAC-e PDU enters MAC from layer 1. After Hybrid ARQ handling, the MAC-e PDU is demultiplexed to form MAC-es PDUs aimed for one or more MAC-d flows. The mapping between the DDI (Data Description Indicator) fields (6 bits) and the MAC-d flow and MAC-d PDU size is provided to the Node B by the SRNC. The mapping of the MAC-d flow into its Iub bearer is defined by the SRNC. A special value of the DDI field indicates that no more data is contained in the remaining part of the MAC-e PDU. The MAC-es PDUs are sent over Iub to MAC-es, where they are distributed by the reordering queue of each logical channel. After re-ordering, the in-sequence data units are disassembled. The resulting MAC-d PDUs are forwarded to MAC-d and finally, C/T demultiplexing enables delivery of each RLC PDU on the correct logical channel.

NOTE: It is possible to bypass the MAC-d C/T multiplexing. The DDI field is then directly used to identify the logical channel(s) mapped on the same MAC-d flow. This is up to UTRAN implementation.





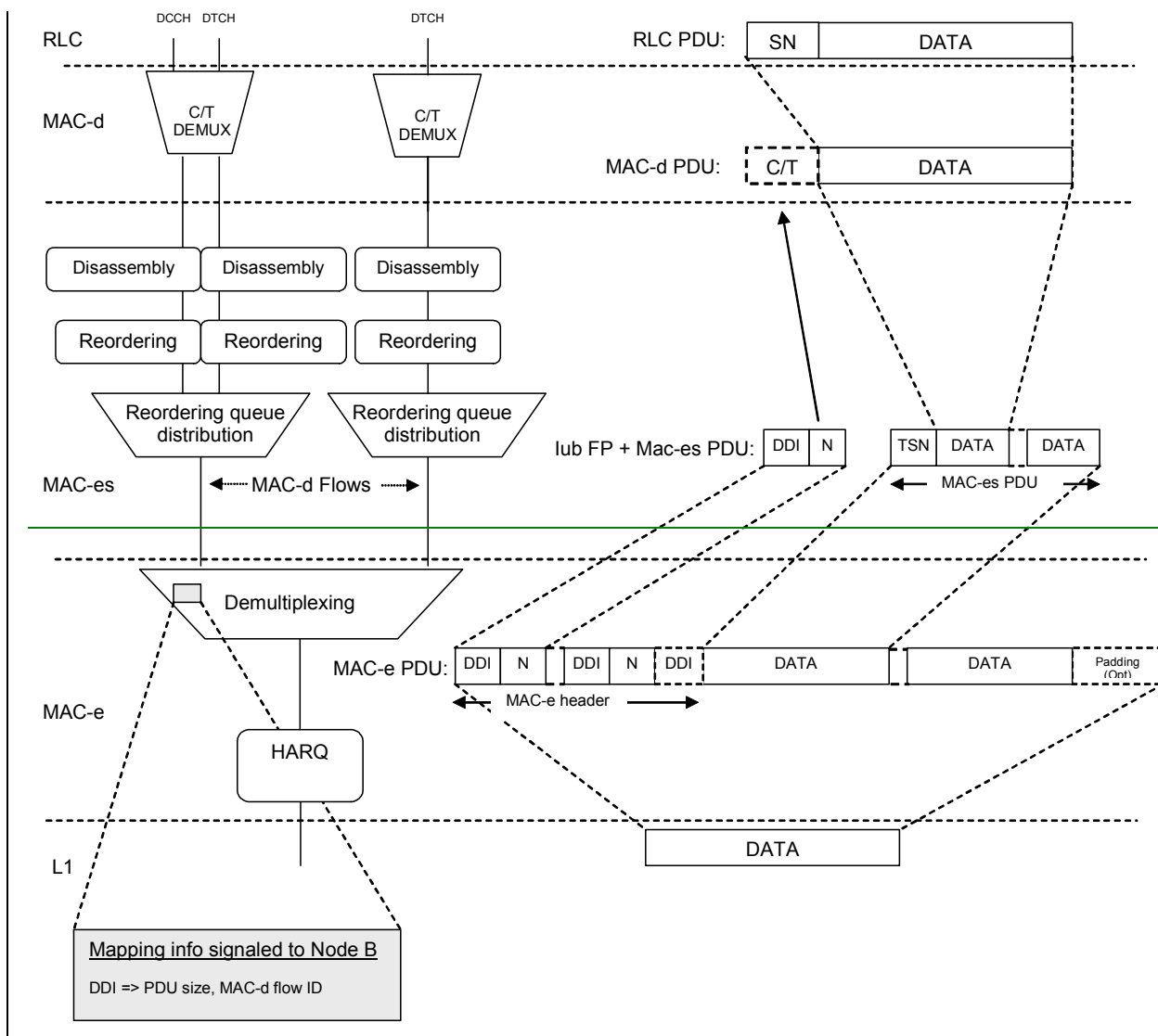

Figure 7.3.1-2: Simplified architecture showing MAC inter-working in UTRAN. The left part shows the functional split while the right part shows PDU decomposition.

7.3.2 Details of MAC-d

For support of E-DCH a new connection to MAC-es is added.

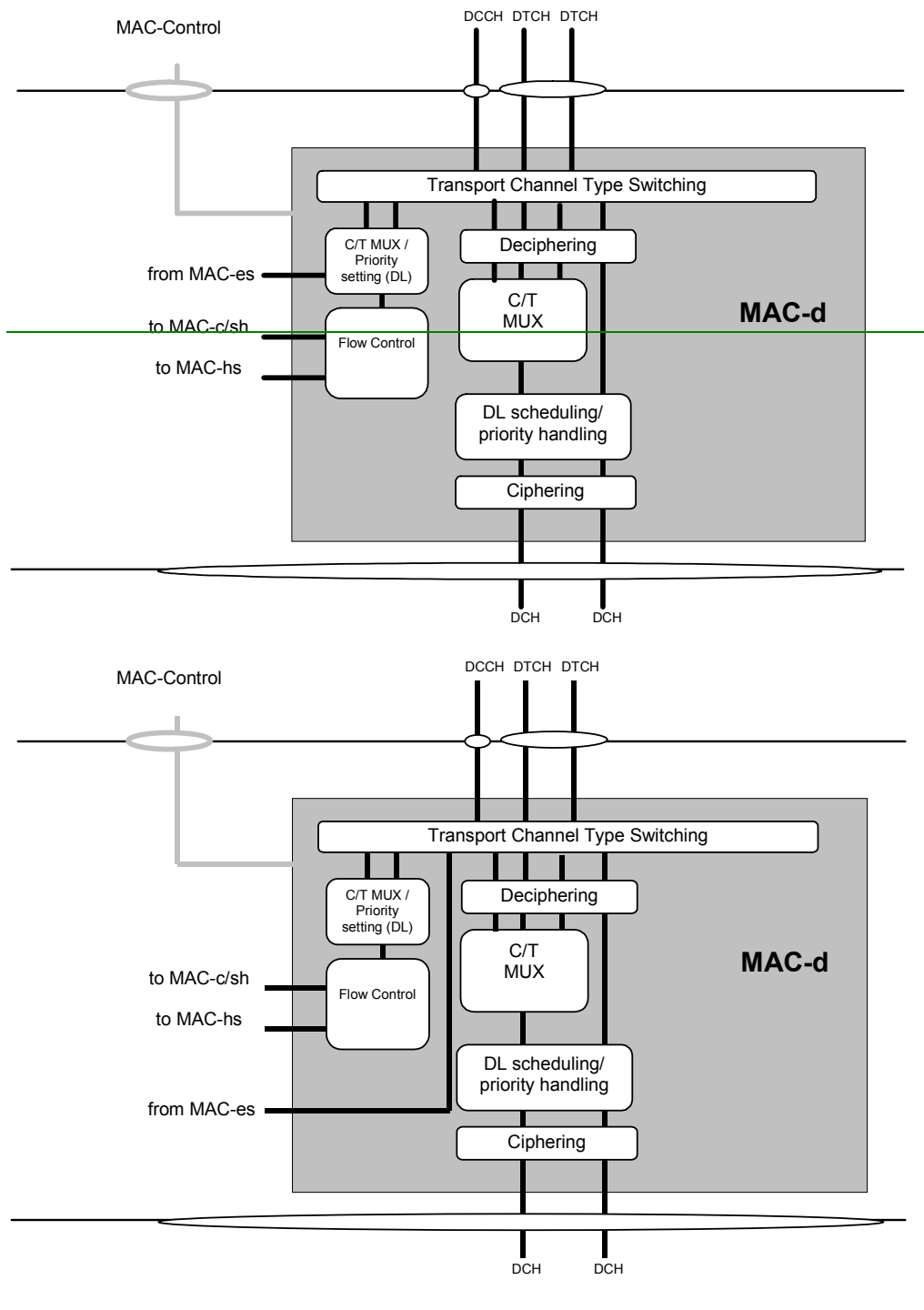

Figure 7.3.2-1: UTRAN side MAC architecture / MAC-d details

7.3.3 Details of MAC-c/sh

The support of E-DCH implies no change to the UTRAN MAC-c/sh entity

7.3.4 Details of MAC-hs

The support of E-DCH implies no change to the UTRAN MAC-hs entity

7.3.5 Details of MAC-es

For each UE, there is one MAC-es entity in the SRNC. The MAC-es sublayer handles E-DCH specific functionality, which is not covered in the MAC-e entity in Node B. In the model below, the MAC-es comprises the following entities:

- Reordering Queue Distribution:
The reordering queue distribution function routes the MAC-es PDUs to the correct reordering buffer based the SRNC configuration.
- Reordering:
This function reorders received MAC-es PDUs according to the received TSN and Node-B tagging i.e. (CFN, subframe number). MAC-es PDUs with consecutive TSNs are delivered to the disassembly function upon reception. PDUs are not delivered to the disassembly function if PDUs with a lower TSN are missing. The number of reordering entities is controlled by the SRNC. There is one Reordering Queue per logical channel.
- Macro diversity selection:
The function is performed in the MAC-es, in case of soft handover with multiple Node-Bs (The soft combining for all the cells of a Node-B takes place in the Node-B). This means that the reordering function receives MAC-es PDUs from each Node-B in the E-DCH active set. The exact implementation is not specified. However the model below is based on one Reordering Queue Distribution entity receiving all the MAC-d flow from all the Node-Bs, and one MAC-es entity per UE.
- Disassembly:
The disassembly function is responsible for disassembly of MAC-es PDUs. When a MAC-es PDU is disassembled the MAC-es header is removed, the MAC-d PDU's are extracted and delivered to MAC-d.

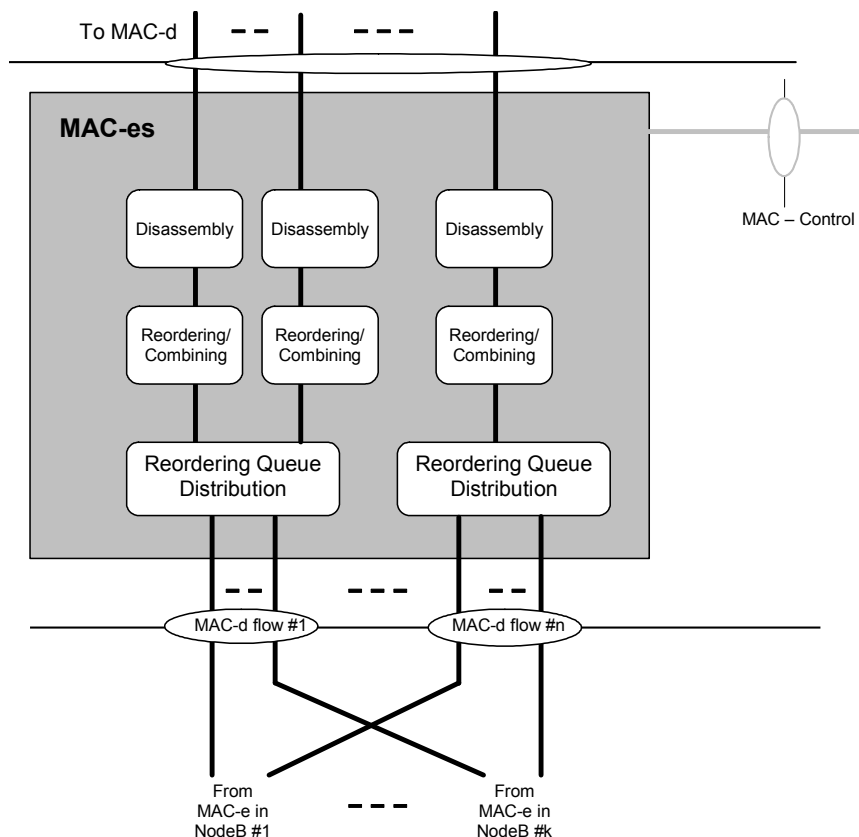

Figure 7.3.5-1: UTRAN side MAC architecture / MAC-es details (SHO case)

7.3.6 Details of MAC-e

There is one MAC-e entity in Node B for each UE and one E-DCH scheduler function in the Node-B. The MAC-e and E-DCH scheduler handle HSUPA specific functions in Node B. In the model below, the MAC-e and E-DCH scheduler comprises the following entities:

- E-DCH Scheduling :
This function manages E-DCH cell resources between UEs. Based on scheduling requests, scheduling assignments are determined and transmitted. The general principles of the E-DCH scheduling are described in subclause 9.1 below. However implementation is not specified (i.e. depends on RRM strategy).
- E-DCH Control :
The E-DCH control entity is responsible for reception of scheduling requests and transmission of scheduling assignments. The general principles of the E-DCH scheduling are described in subclause 9.1 below.
- De-multiplexing:
This function provides de-multiplexing of MAC-e PDUs. MAC-es PDUs are forwarded to the associated MAC-d flow.
- HARQ:
One HARQ entity is capable of supporting multiple instances (HARQ process) of stop and wait HARQ protocols. Each process is responsible for generating ACKs or NACKs indicating delivery status of E-DCH transmissions. The HARQ entity handles all tasks that are required for the HARQ protocol.

The associated signalling shown in the figure illustrates the exchange of information between layer 1 and layer 2 provided by primitives.

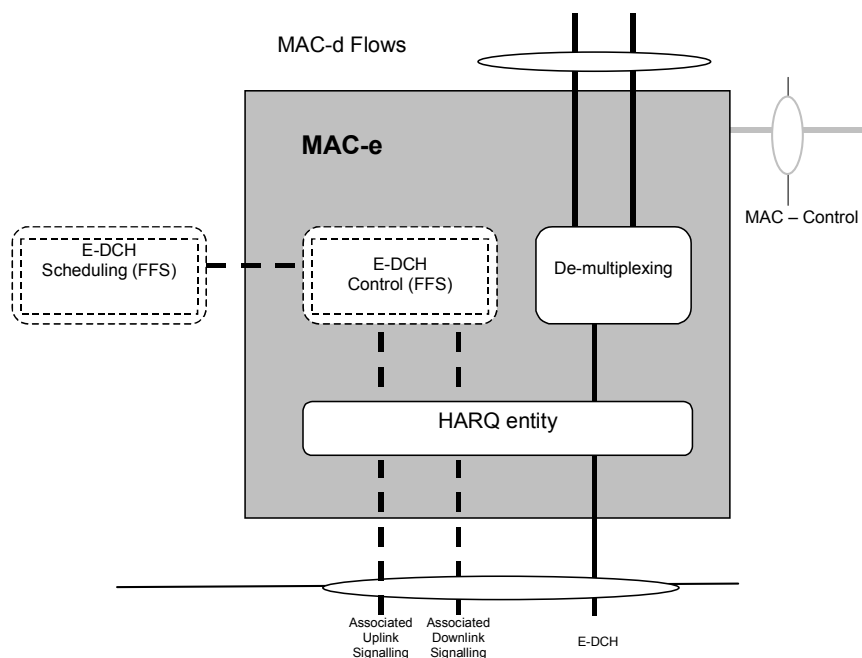

Figure 7.3.6-1: UTRAN side MAC architecture / MAC-e details

8 HARQ protocol

8.1 General Principle

The HARQ protocol has the following characteristics:

- Stop and wait HARQ is used;
- The HARQ is based on synchronous downlink ACK/NACKs;

- The HARQ is based on synchronous retransmissions in the uplink:
 - The number of ~~processes~~ ~~process numbers~~ depends on the TTI: 8 processes for the (i.e. 2ms TTI and 4 processes for the 10ms). The target is to have one value per TTI. The exact numbers are FFS;
 - There will be an upper limit to the number of retransmissions. The UE decides on a maximum number of transmissions for a MAC-e PDU based on the maximum number of transmissions attribute (see subclause ~~11.4.1.1~~ 11.4.1.1), according to the following principles:
 - The UE selects highest maximum number of transmissions among all the considered HARQ profiles associated to the MAC-d flows in the MAC-e PDU;
 - Further optimisations such as explicit rules set by the SRNC are FFS.
 - Pre-emption will not be supported by E-DCH;
 - In case of TTI reconfiguration, the MAC-e HARQ processes are flushed and no special mechanism is defined to lower SDU losses
- Intra Node B macro-diversity and Inter Node B macro-diversity should be supported for the E-DCH with HARQ;
- Incremental redundancy shall be supported by the specifications with Chase combining as a subcase:
 - The first transmission shall be self decodable;
 - The UTRAN configures the UE to either use the same incremental redundancy version (RV) for all transmissions, or to set the RV according to set of rules based on E-TF, Retransmission Sequence Number (RSN) and the transmission timing;
 - There shall be no need, from the H-ARQ operation point of view, to reconfigure the Node B from upper layers when moving in or out soft handover situations. However, the Node-B may be aware of the soft handover status via a soft handover indicator.

8.2 Error handling

The most frequent error cases to be handled are the following:

- NACK is detected as an ACK: the UE starts afresh with new data in the HARQ process. The previously transmitted data block is discarded in the UE and lost. Retransmission is left up to higher layers;
- ACK is detected as a NACK: if the UE retransmits the data block, the NW will re-send an ACK to the UE. If in this case the transmitter at the UE sends the RSN set to zero, the receiver at the NW will continue to process the data block as in the normal case;
- Error cases have been identified regarding the HARQ operation during soft handover:
 - o In case the HARQ control information transmitted on the E-DPCCH could not be detected RSN_max times in a row for one HARQ process, a soft buffer corruption might occur. Each HARQ process uses RSN and the transmission time (CFN, sub-frame) elapsed since storing data in the associated soft buffer in order to flush the soft buffer and to avoid a wrong combining of data blocks.
 - o Duplication of data blocks may occur at the RNC during soft handover. The reordering protocol needs to handle the detected duplications of data blocks.

8.3 Signalling

8.3.1 Uplink

8.3.2 Downlink

In the downlink, a report is used to indicate either ACK (positive acknowledgement) or NACK (negative acknowledgement).

9 Node B controlled scheduling

9.1 General Principle

The Node B controlled scheduling is based on uplink and downlink control together with a set of rules on how the UE shall behave with respect to this signaling.

In the downlink, a resource indication (Scheduling Grant) is required to indicate to the UE the maximum amount of uplink resources it may use. When issuing Scheduling Grants, the Node B may use QoS-related information provided by the SRNC (see subclause [11.4.1.1](#)) and from the UE in [a-Scheduling Request](#) (see subclause 9.3.1)

The Scheduling Grants have the following characteristics:

- Scheduling Grants are only to be used for the E-DCH TFC selection algorithm (i.e. they do not influence the TFC selection for the DCHs);
- Scheduling Grants control the maximum allowed E-DPDCH/DPCCH power ratio;
- All grants are deterministic;
- Scheduling Grants can be sent once per TTI or slower;
- There are two types of grants:
 - The Absolute Grants provide an absolute limitation of the maximum amount of UL resources the UE may use;
 - The Relative Grants increase or decrease the resource limitation compared to the previously used value;
- Absolute Grants are sent by the Serving E-DCH cell:
 - They are valid for one UE, for a group of UEs or for all UEs;
 - They can have an associated duration (FFS);
 - The Absolute Grant contains:
 - ~~at least~~ the identity (E-RNTI) of the UE (or group of UEs) for which the grant is intended;
 - ~~and~~ the maximum power ratioresources the UE is allowed to(s) may use;
 - a flag indicating if the Absolute Grant is applicable to a single process or to all processes, in case of 2ms TTI (Note: the per-process approach is only possible for the "RG" based mode). For the 10ms TTI, the use of the bit encoding the flag is FFS.
 - Group identities or dedicated identities are not distinguished by the UE (i.e. the UE behaviour is exactly the same). It is up to the UTRAN to allocate the same identity to a group of UEs;
 - One identity (E-RNTI) is allocated to a UE at a time. The allocation is done by the Node-B and sent by the SRNC in RRC.
 - The identity consists of 16 bits (16 bits CRC at layer 1);
 - In case of 2ms TTI, an Absolute Grant can be associated to a single process (only for the "RG" based mode), or to all processes (for both "RG" and "Non RG" modes);
 - In case of 10ms TTI, an Absolute Grant is associated to all processes (for both "RG and "Non RG" modes);
- Relative Grants (updates) are sent by the Serving and Non-Serving Node-Bs as a complement to Absolute Grants:

- The UE behaviour is exactly the same for Relative Grants for one UE, for a group of UEs and for all UEs;
- The Relative Grant from the Serving E-DCH RLS can take one of the three values: “UP”, “HOLD” or “DOWN”;
- The Relative Grant from the Non-serving E-DCH RLS can take one of the two values: “HOLD” or “DOWN”. The “HOLD” command is sent as DTX. The “DOWN” command corresponds to an “overload indicator”;
- For each UE, the non-serving Node-B operation is as follows:
 - If the Node-B could not decode the E-DPCCH/E-DPDCH for the last n_1 TTIs (where n_1 is TBD) because of processing issue, it shall notify the SRNC;
 - The non-serving Node-B is allowed to send a “DOWN” command only for RoT reasons (maximum allocated uplink RoT in the cell is exceeded) and not because of lack of internal processing resources.

9.2 UE scheduling operation

9.2.1 Grants from the Serving RLS

The UE shall be able to receive Absolute Grant from the Serving E-DCH cell and Relative Grant from the Serving E-DCH RLS.

Two UE scheduling mode of operation are defined (“RG” based and “Non RG” based).

~~NOTE:—The description below is generic. It currently makes reference to the rate but it may have to be translated into the power dimension.~~

If E-RGCH physical channels are allocated for the cells of the Serving E-DCH RLS, the UE shall follow the “RG” based mode of operation and handle the ~~grant~~Grant from the Serving E-DCH RLS as follows:

- The UE maintains a “Serving Grant” (SG_i) for each HARQ process i ;
- The ~~SG~~ SG_i is used in the E-TFC selection algorithm as the maximum allowed ~~rate~~E-DPDCH/DPCCH power ratio for the transmission of the HARQ process it refers to;
- ~~—The SG is set equal to the “Absolute Grant” value when one is received from the Serving E-DCH cell;~~
- ~~—If no “Absolute Grant” is received by the UE, then the UE will follow the “Relative Grant” of the Serving E-DCH RLS;~~
- ~~—The SG is not modified when the UE receives a “HOLD” from the Serving E-DCH RLS;~~
- The SG_i is updated according to the following algorithm, regardless of the transmission/retransmission status of the HARQ process. The SG_i is not used for the E-TFC selection algorithm if the HARQ process is in retransmission;
- When receiving an “Absolute Grant” on the E-AGCH of the serving E-DCH cell:
 - In case of 10ms TTI, SG_i is set to the received value for all HARQ processes;
 - In case of 2ms TTI, SG_i is set to the received value either for all HARQ processes or for one process only depending on the *SingleProcess* flag of the E-AGCH.
- If no “Absolute Grant” is received by the UE, then the UE shall follow the “Relative Grant” of the Serving E-DCH RLS:
 - A Serving Relative Grant is interpreted relative to the UE power ratio in the previous TTI for the same hybrid ARQ process as the transmission which the Relative Grant will affect (see figure 9.2.1-1);

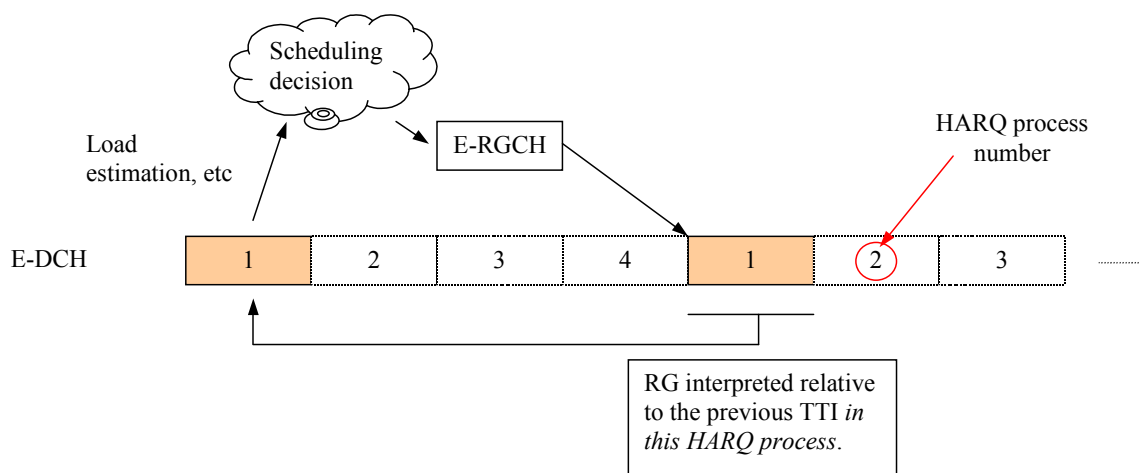

Figure 9.2.1-1: Timing relation for Relative Grant

- When the UE receives an “UP” from Serving E-DCH RLS:
 - New $SG_i = \text{Last used bit rate power ratio } (i) + \text{Delta}$;
- When the UE receives a “DOWN” from Serving E-DCH RLS:
 - New $SG_i = \text{Last used bit rate power ratio } (i) - \text{Delta}$;

If no E-RGCH physical channels are allocated for the cells of the Serving E-DCH RLS, the UE shall follow the “Non RG” based mode of operation and handle the grant. When the UE receives a “HOLD” (i.e. DTX) from the Serving E-DCH RLS as follows:

- In case of 2ms TTI, SG_i remains unchanged (per process approach);
- In case of 10ms TTI: SG_i in the immediate preceeding TTI is reused for the current TTI: new $SG_i = SG_{i-1}$ (per UE approach).

If no E-RGCH physical channels are allocated for the cells of the Serving E-DCH RLS, the UE shall follow the “Non RG” based mode of operation and handle the grants from the Serving E-DCH RLS as follows:

- The UE maintains a “Serving Grant” (SG);
- The SG is used in the E-TFC selection algorithm as the maximum allowed $\text{rate E-DPDCH/DPCCH power ratio for the transmission of the HARQ process it refers to}$;
- The UE sets the “MAX Serving Grant” (MAX SG) to the last received “Absolute Grant” (AG) for all processes when the UE is not in the hysteresis period;
- The UE sets the “MAX Serving Grant” (MAX SG) to the minimum of “Current MAX SG” and “the last received Absolute Grant (AG)” when the UE is in the hysteresis period;
- If the UE has data to transmit and the SG is below the MAX SG, the SG is increased over time by configurable steps (autonomous ramp-up) until SG is equal to MAX SG;
- If the SG is above the MAX SG (due to reception of a new AG lowering the MAX SG), then the SG is immediately set equal to MAX SG;
- If the UE transmitted at a given rate power ratio below the current SG for more than n TTIs (where n is a configurable parameter that can be set to an infinite value), then the SG is set equal to this given rate power ratio . This in effect forces the UE to use autonomous ramp-up after some continuous activity below SG.

It is FFS whether or not the “per process” approach can be used for the “Non RG” based mode of operation, i.e. whether the *SingleProcess* flag of the E-AGCH can be set for 2ms TTI.

9.2.2 Grants from the Non-serving RLS

Node-B from the Non-serving E-DCH RLS will only send Relative Grants to the UE. The UE shall handle the RG from the Non-serving E-DCH RLS as follows:

- When the UE receives a "DOWN" from at least one Non-serving E-DCH RLS;
 - ~~— New SG = —For all HARQ processes (for all i):~~
 - ~~— For the "RG" mode of operation: new $SG_i =$ Last used ~~bit rate~~power ratio (i) – Delta;~~
 - ~~— For the "Non RG" mode of operation: new MAX SG = MAX SG – Delta;~~
- The Delta may be dependant on the bit rate;
 - The option to use a calculated offset is FFS (e.g. the offset may be function of the measured CPICH power on the overloaded cells in relation to the measured CPICH power on the serving cell);
- ~~— Stability may be obtained via a configurable hysteresishysteresis after "DOWN" commands are received. Details are FFS.~~
- When the UE does not receive a "DOWN" from any Non-serving E-DCH RLSs;
 - The UE shall follow the Serving E-DCH RLS's Scheduling Grants.

9.2.3 Reception of Grants from both the Serving and Non-serving RLS

In the case of a UE receiving grants from both the Serving and Non-Serving RLS, the UE behaviour is the following:

- ~~— When the UE receives a scheduling grant from the Serving E-DCH RLS and a "DOWN" command from at least one Non-Serving E-DCH RLS:~~
 - ~~— For every HARQ process (for every i):~~
 - ~~— For the "RG" mode of operation: new SG_i is set to the minimum between the Last used power ratio minus Delta and the received AG/RG from serving RLS;~~
 - ~~— For the "non-RG" mode of operation: new MAX SG is set to the minimum between MAX-SG minus Delta and the received AG/RG from serving RLS.~~

9.3 Signalling

9.3.1 Uplink

For the UE to request resources from the Node B(s), Scheduling Requests will be transmitted in the uplink-

in the form of Scheduling Information and Happy Bit. The Scheduling Request contains the following type of information will be transmitted for the logical channels for which RRC configured that reporting needs to be made, while the Happy Bit shall be transmitted on the E-DPCCH always.

- ~~— UE Buffer occupaney;~~
- ~~— Estimation of the available or needed power/rate;~~
- ~~— Further information needed and details are FFS;~~

~~In the case where the UE's "Serving Grant" (SG) equals to zero and it has data to send, a Scheduling Request shall be sent to the Serving E-DCH RLS in a MAC-e PDU. The transmission shall be non-scheduled.~~

~~In the case where the UE's "Serving Grant" (SG) is above zero, it shall send has a scheduling grant, the Scheduling Request to the Serving E-DCH RLS along with the data in the MAC-e PDU. The details on when and how Scheduling Requests are included in the MAC-e PDU are FFS. In addition, it is FFS whether an additional request bit will be sent in the E-DPCCH. This bit would indicate whether or not the UE is satisfied with the current SG (details are FFS).~~

~~It is FFS if the Scheduling Request content and size depend on whether the UE simultaneously transmits data or not.~~

9.3.1.1 Scheduling Information

9.3.1.1.1 Content

The UE includes the following in the Scheduling Information (only taking into account the logical channels for which RRC configured that reporting was required):

- Logical channel ID of the highest priority channel (which is configured by RRC as needing reporting) with data in buffer;
- UE Buffer occupancy (in Bytes):
 - Buffer status for the highest priority logical channel with data in buffer;
 - Total buffer status;
- Estimation of the available power ratio versus DPCCH (taking into account HS-DPCCH). UE shall not take backoff and DCH power into account when performing the estimation. Whether the backoff is taken into account or not is FFS;

9.3.1.1.2 Triggers

In the case where the UE's "Serving Grant" (SG) equals to zero (i.e. UE has no Scheduling Grant) and it has Scheduled data to send on a logical channel for which Scheduling Information must be reported:

- Scheduling Information shall be sent to the Serving E-DCH RLS in a MAC-e PDU;
- Periodic reporting to protect against NACK-to-ACK misinterpretation;
- Scheduling Information could be sent alone, or with non-scheduled data, if such exist.

In the case where the UE's "Serving Grant" (SG) is above zero (i.e. UE has a scheduling grant):

- it shall send the Scheduling Information to the Serving E-DCH RLS in the MAC-e PDU;
 - the Scheduling Information is sent periodically (period defined by RRC);
 - use of events to trigger Scheduling Information is FFS.

The details on how Scheduling Information is included in the MAC-e PDU are FFS.

9.3.1.1.3 Transmission and Reliability scheme

Two transmission mechanisms are defined, depending on whether the Scheduling Information is transmitted alone, or with data (scheduled or non-scheduled):

1. When the Scheduling Information is sent alone (i.e. the UE has no Scheduling Grant or it has a Scheduling Grant but no data to transmit):
 - HARQ (re)transmissions are performed until ACK from serving cell is received or until the max number of re-transmissions is reached;
 - The power offset is configured by RRC;

- The max number of re-transmissions is defined by the standard.
- 2. When Scheduling Information is sent with scheduled data:
 - Use the HARQ profile of the data for the MAC-e PDU for transmission;
 - Transmission reliability mechanism is FFS.
- 3. In case Scheduling Information is sent with non-scheduled data, the use of a special rule for setting the power offset is FFS.

9.3.1.2 Happy bit of E-DPCCH

One bit of the E-DPCCH is used to indicate whether or not the UE is satisfied ('happy') with the current Serving Grant. This bit shall always be present during uplink transmission.

The UE shall indicate that it is 'unhappy' if both of the following criteria are met:

- 1) UE has Power available to send at higher data rates (E-TFCs) (link to E-TFC selection/elimination over recent past is FFS, filtering is FFS), and
- 2) Total buffer status would require more than X TTIs with the current Grants (where X is configurable). Details are FFS.

Otherwise, the UE shall indicate that it is 'happy'.

9.3.2 Downlink

For each UE, there is only one Absolute Grant transmitted by the serving E-DCH cell using the E-AGCH.

For each UE, there is in one Relative Grant transmitted per Serving and Non-serving RLS from the E-DCH active set cells. The channel(s) (one per cell) on which the Relative Grant is transmitted is(are) signalled separately to each UE (this allows for the same channel to be monitored by multiple UEs if it is UTRAN decision).

10 Non-scheduled transmissions

When non-scheduled transmission is configured by the SRNC, the UE is allowed to send E-DCH data at any time, up to a configured bitrate, without receiving any scheduling command from the Node B. Thus, signalling overhead and scheduling delay are minimized.

Typical examples of data that may use non-scheduled transmission are the SRBs and GBR services.

Non-scheduled transmissions have the following characteristics:

- Non-scheduled transmissions are defined per MAC-d flow;
- The resource for non-scheduled transmission is given in terms of bit rate by the SRNC, and is called non-scheduled granted rate;
 - Scheduled logical channels cannot use the non-scheduled granted rate;
- UTRAN can restrict a non-scheduled MAC-d flow to use a limited number of HARQ processes in case of 2ms TTI. The same restriction for the 10ms TTI is FFS;
- UTRAN can reserve some HARQ processes for non-scheduled transmission (i.e. scheduled data cannot be sent using these processes) in case of 2ms TTI. The same reservation scheme for the 10ms TTI is FFS;
- Multiple non-scheduled MAC-d flows may be configured in parallel by the SRNC;
 - The UE is then allowed to transmit non-scheduled transmissions up to the sum of the non-scheduled granted rates if multiplexed in the same TTI;

- Scheduled grants will be considered on top of non-scheduled transmissions;
- Logical channels mapped on a non-scheduled MAC-d flow cannot transmit data using a Scheduling Grant;
- Logical channels mapped on a non-scheduled MAC-d flow can only transmit up to the non-scheduled granted rate configured for that MAC-d flow;
- The multiplexing list restricting the set of HARQ profiles that can be used by a given logical channel will apply both for scheduled and non-scheduled logical channels;
- Logical channels will be served in the order of their priorities until the non-scheduled granted rate and scheduled grants are full, or the maximum transmit power is reached;
 - When multiple logical channels are assigned the highest priority, the selection of the HARQ profile for these logical channels is not specified;

110 QoS control

110.1 General Principle

The QoS of ongoing flows mapped on E-DCH for a UE is maintained by the serving Node B and by the UE. The Node B controls the resources allocated to a UE versus other UEs by means of scheduling as specified in clause 9. The UE controls the QoS of all its logical channels mapped on E-DCH by means of E-TFC selection as specified in subclause 11.2, and by HARQ operation, specified in clause 8.

In addition to these mechanisms, guaranteed bit rate services for MAC-d flows are also supported through non-scheduled transmission. A flow using non-scheduled transmission is defined by the SRNC and provided in the UE and in the Node B. ~~The UE can transmit data belonging to such flow without first receiving any scheduling grant.~~ Details on non-scheduled transmission can be found in section 10.

110.1.1 QoS configuration principles

RAB attributes are available in the SRNC according to R'99 principles. To enable QoS control for the E-DCH, QoS-related information is made available in the UE and in the Node B as outlined below.

To the UE, the following QoS-related information is provided from the SRNC to enable QoS-based E-TFC selection, multiplexing of logical channels in MAC-e PDUs, and HARQ operation:

- Logical channel priority for each logical channel (as in Rel-5);
- Mapping between logical channel(s) and MAC-d flow(s) (as in Rel-5);
- Allowed MAC-d flow combinations in one MAC-e PDU;
- Reference power offset for a pre-defined E-TFC. The UE then calculates reference power offsets for its other E-TFCs [FFS, RAN WG1 confirmation needed] so that the quality (protection of MAC-e PDU) when using any of the E-TFCs is identical to that of the reference E-TFC;
- HARQ profile per MAC-d flow. One HARQ profile consists of a power offset attribute and a maximum number of transmissions attribute. The power offset attribute is used in E-TFC selection to regulate the BLER operating point for the transmission. The maximum number of transmissions attribute is used in the HARQ operation to regulate maximal latency and residual BLER of MAC-d flows.
- ~~Number of bits per TTI corresponding to the guaranteed~~ The non-scheduled granted bit rate (only for MAC-d flows /logical channels (FFS) that carry are configured for non-scheduled transmission guaranteed bit rate services).

To the Node B, the following QoS-related parameters are provided by the SRNC to enable scheduling and resource reservation:

- Power offset or E-TFC (FFS) that corresponds to the guaranteed bit rate (only for MAC-d flows /logical channels that carry guaranteed bit rate services). For scheduled transmission, it is used to allocate grants to UEs. For non-scheduled transmission, it is used for the Node B to reserve sufficient amount of resources. The need for additional mechanisms to optimize the Node-B hardware is FFS (e.g. the UE may tell the Node-B ahead that a non-scheduled transmission is coming);

1140.2 TFC and E-TFC selection

Logical channels mapped on the DCHs are always prioritised over those mapped on E-DCHs.

The principle of the TFC selection across E-DCH and DCH is the following:

- The UE performs TFC restriction~~maintains a list of allowed TFCs~~ for the CCTrCH of DCH type;
- The UE performs the TFC selection for the DCHs;
- E-TFC restriction is performed with the following characteristics:
 - The E-TFC restriction mechanism is independent of the existing TFC restriction;
 - The E-TFC states defined per MAC-d flow are managed independently of the TFC states;
 - The HS-DPCCH and DPCCH are taken into account;
- Every E-DCH TTI, the UE shall estimate the remaining power versus DPCCH (taking into account HS-DPCCH);
- Then it performs the TFC selection for the E-DCH, with the estimated remaining power, taking into account DCH power and the following rules:
 - The E-TFC selection is based on logical channel priorities like in the Release '99, i.e. the UE shall maximise the transmission of higher priority data;
 - The UE shall respect the allowed combinations of MAC-d flows in the same MAC-e PDU;
 - The UE shall use the multiplexing list of the different MAC-d flows to see if a certain MAC-d flow can use the power offset of the highest priority MAC-d flow to be transmitted;
 - The power offset of E-DPDCH(s) relative to DPCCH associated to a MAC-e PDU including MAC-d PDUs coming from one or several MAC-d flows is set as follows:
 - The UE selects the power offset of the HARQ profile associated to the MAC-d flows with the highest priority logical channel in the MAC-e PDU;
 - The UE adds the resulting power offset for the MAC-e PDU to the previously calculated reference power offsets for different E-TFCs. It then selects the E-TFC, taking into account the obtained power offsets, the required E-TFC-dependent power back-off, the UE's remaining power and the amount of data to be transmitted.
 - For each transmission, the MAC-e entity gives the selected power offset of E-DPDCH(s) relative to DPCCH to the L1 in addition to the E-TFC;
 - ~~What should be done when this exceeds the L1 maximum transmission power is FFS.~~
 - In case the maximum UE transmit power is exceeded, the UE shall scale down the E-DPDCH only on TTI level for retransmissions. At slot level all uplink physical channels are equally compressed. The scaling down of only E-DPDCH at slot level remains FFS.
- In addition, the UE may need not to go below a minimum rate for the E-DCH. In some case, this means that the UE may have to power scale down all physical channels present;
- An E-DCH minimum set because of power limitation is needed. Details are FFS.

1140.3 Setting of Power offset attributes of MAC-d flows

Power offset attributes of MAC-d flows are part of the HARQ profiles of the MAC-d flow. They are provided by the UTRAN to the UE according to the following principles:

- The DPCCH transmission power is controlled the same way as in Release '99;
- In case where there is no need for a DCH (i.e. the SRBs are mapped on the E-DCH), a size 0 TrBck may be required (FFS);
- With each MAC-es PDU transmitted to the SRNC, the Node-B includes the number of transmissions that have been required to correctly decode the PDU;
- Using the information provided by the Node B, the SRNC may maintain up to date power offsets;
- The SRNC may decide to signal to the UE new values for the power offset attributes for one (or several) MAC-d flows.
- No other power management/control mechanism is needed for E-DCH.

1244 Signalling parameters

1244.1 Uplink signalling parameters

4412.1.1 Transport block size

This defines what transport block size is used in the corresponding E-DCH TTI. The signalled parameter is an index to a pre-defined set of available transport block sizes. Four different sets of transport block sizes are defined:

- Exponentially distributed TB sizes over the corresponding dynamic range for both 2 and 10ms TTI;
- Optimized TB sizes for 336 bit RLC PDU size for both 2 and 10ms TTI.

4412.2 Downlink signalling parameters

With RRC signalling, the UE will in addition be informed about:

- The E-HICH configuration
 - Including signature sequence number and channelisation code;
- The E-RGCH configuration
 - Including signature sequence number, channelisation code and Serving/Non-serving E-DCH RLS ID;
- The E-AGCH configuration
 - Including E-RNTI and channelisation code;
- The E-DPCCH configuration
 - Including E-DPCCH/DPCCH Power Offset;
- The E-DPDCH configuration:

- A number (how many is TBD) of tables are defined by the standard, each defining a set of E-TFC (or E-TFCS). A UE is allocated one and only one E-TFCS table by RRC.
- For each E-TFC a (nominal) beta factor is calculated based on reference power offset signalled for reference E-TFCs by RRC (number of reference E-TFCs is FFS);
- HARQ Incremental Redundancy Version configuration. Always use RV=0 or use the RV table;
- Maximum number of E-DPDCH channelisation code;
- Minimum SF;
- It is FFS whether in addition puncturing limits will need to be signalled by RRC or not;
- E-DCH Scheduling Information parameters:
 - Logical channels for which Scheduling Information is expected to be reported by the UE;
 - Period for sending Scheduling Information (applicable when no Scheduling Grant has been received);
 - Period for sending Scheduling Information (applicable once a Scheduling Grant has been received);
 - Power offset to use when sending Scheduling Information alone;
 - Threshold (in TTIs) used by the UE when evaluating the time needed to completely empty its buffers. Used as a conditions for setting the 'happy' bit in E_DPCCH.

RRC will signal the mapping between logical channel, MAC-d PDU size, MAC-d flow ID and Data Description Indicator (see clause 7).

RRC will signal for each MACd-flow, the MAC-d flow specific power offset, the maximum number of transmissions, and the multiplexing list (indicating with which other MAC-d flows, MAC-d PDU's of this flow can be multiplexed in the same MAC-e PDU).

1312 Mobility procedures

Annex A (informative): Change history

Change history							
Date	TSG #	TSG Doc.	CR	Rev	Subject/Comment	Old	New
09/2004	RP-25	RP-040358	-		Approved at TSG-RAN #25 and placed under Change Control.	1.0.0	6.0.0
12/2004	RP-26	RP-040486	001	3	Inclusion of e.g. physical layer model, MAC architecture, detail Node B scheduler mechanism and QoS Control principles	6.0.0	6.1.0
	RP-26	RP-040487	002	2	Scheduling Grants as E-DPDCH/DPCCH power ratio	6.0.0	6.1.0
	RP-26	RP-040486	003	1	Proposed rewording on scheduler sections compared to CR 001r3	6.0.0	6.1.0