

Presentation of Specification to TSG or WG

Presentation to: TSG RAN Meeting #20

Document for presentation: TR 25.889, Version 2.0.0

Presented for: Approval

Abstract of document:

This document is a Technical Report on Release 6 Study Item "Feasibility Study considering the viable deployment of UTRA in additional and diverse spectrum arrangements".

Changes since last presentation to TSG RAN Meeting #18:

RAN WG4 has held 1 meeting since the status was lastly presented to TSG RAN #19.

The Conclusion Chapter has been completed and included in the report version 1.4.0, which was presented again during RAN4#27. This version was approved to be presented to RAN as Version 2.0.0.

Outstanding Issues:

None.

Contentious Issues:

None .

3GPP TR 25.889 V2.0.0 (2003-05)

Technical Report

**3rd Generation Partnership Project;
Technical Specification Group Radio Access Network;
Feasibility Study considering the viable deployment of UTRA
in additional and diverse spectrum arrangements
(Release 6)**



The present document has been developed within the 3rd Generation Partnership Project (3GPP™) and may be further elaborated for the purposes of 3GPP.

The present document has not been subject to any approval process by the 3GPP Organizational Partners and shall not be implemented. This Specification is provided for future development work within 3GPP only. The Organizational Partners accept no liability for any use of this Specification. Specifications and reports for implementation of the 3GPP™ system should be obtained via the 3GPP Organizational Partners' Publications Offices.

Select keywords from list provided in specs database.

Keywords

<keyword[, keyword]>

3GPP

Postal address

3GPP support office address

650 Route des Lucioles - Sophia Antipolis
Valbonne - FRANCE
Tel.: +33 4 92 94 42 00 Fax: +33 4 93 65 47 16

Internet

<http://www.3gpp.org>

Copyright Notification

No part may be reproduced except as authorized by written permission.
The copyright and the foregoing restriction extend to reproduction in all media.

© 2002, 3GPP Organizational Partners (ARIB, CWTS, ETSI, T1, TTA, TTC).
All rights reserved.

Contents

Foreword.....	6
Introduction.....	6
1 Scope.....	7
2 References.....	7
3 Definitions, symbols and abbreviations.....	8
3.1 Definitions.....	8
3.2 Symbols.....	8
3.3 Abbreviations.....	8
4 Background and Introduction.....	9
4.1 Scope and Objective of work.....	9
4.1.1 General considerations.....	9
4.1.2 UTRA FDD.....	9
4.1.3 UTRA TDD.....	10
4.1.4 Caveat/Notice.....	10
5 Description of the spectrum arrangements.....	11
6 Enabling technologies for operation of UTRA FDD in the new bands.....	12
6.1 Solutions for implementing variable duplex separation in one terminal.....	12
6.1.1 Status in 3GPP specifications for accommodating variable duplex separation in one terminal.....	12
6.1.1.1 Signalling and control of the UE (RAN2).....	12
6.1.1.1.1 Common channel aspects.....	12
6.1.1.1.2 Dedicated channel aspects.....	13
6.1.1.1.3 UE capability aspects.....	13
6.1.1.1.4 Signalling summary.....	13
6.1.1.2 Frequency bands and hardware issues (RAN4).....	14
6.1.1.2.1 Frequency bands.....	14
6.1.1.2.2 RF performance.....	14
6.1.2 Examples of Implementation of variable duplex separation in one terminal.....	14
6.1.3 VDT Conclusion.....	16
6.2 Solutions for having a terminal accommodating frequency band asymmetry.....	16
7 Examples for viable implementations of spectrum arrangements for UTRA FDD.....	17
7.1 DL usage of the new band 2500 – 2690 MHz in conjunction with the Band I for UTRA FDD.....	17
7.1.1 Radio Network Performance Aspects regarding utilization of the 2500 – 2690 MHz Band.....	17
7.1.1.1 Relevant Propagation Aspects for 2.5 GHz Band.....	17
7.1.1.2 Impact of increased PL in the 2.5 GHz band on UTRA UL/DL Cell Coverage.....	17
7.1.2 Towards an UTRA Standard for supporting DL optimised utilisation of the 2500 – 2690 MHz band.....	18
7.1.2.1 Overall Objectives for UTRA 3GPP standards development to support DL optimised utilisation of the 2500 – 2690 MHz band.....	19
7.1.2.2 Towards a technical framework for extending UTRA to support DL optimised utilisation of the 2500 – 2690 MHz band.....	19
7.1.3 Radio Resource Management (RRM) aspects with extension DL carriers in 2500 – 2690 MHz.....	21
7.1.3.1 UL interference scenario.....	21
7.1.3.2 Interference detection and avoidance.....	21
7.1.4 Needed Additions to the UTRA Standard for supporting DL optimised utilisation of the 2500 – 2690 MHz band.....	23
7.1.5 Summary of section 7.1 for usage of the new band in 2500 – 2690 MHz in conjunction with the Band I for UTRA.....	23
7.2 Use of VDT for deployment of public indoor systems.....	24
7.2.1 Introduction to the scenario.....	24
7.2.2 Assumptions for the scenario.....	24
7.2.3 UL interference from increased traffic in indoor system.....	25
7.2.4 Controlling the UL interference with the use of VDT.....	26
7.2.5 Summary of the use of VDT for deployment for public indoor systems.....	28

7.2.6	Handover between cells with different duplex spacing	28
7.3	UL/DL usage of the new band in 2500 – 2690 MHz in conjunction with the Band I for UTRA FDD	28
7.3.1	Introduction.....	28
7.3.2	General aspects regarding “Alternative B” within 2500 – 2690 MHz.....	29
7.3.3	Interference mechanisms relevant for “Alternative B” within 2500 – 2690 MHz.....	29
7.3.4	RF Performance requirements for supporting “Alternative B” within 2500 – 2690 MHz.....	30
7.3.5	Summary.....	31
7.4	UL/DL plus additional DL usage of the new band in 2500 – 2690 MHz in conjunction with the Band I for UTRA FDD	31
7.4.1	Introduction.....	31
7.4.2	General aspects regarding “Alternative C” within 2500 – 2690 MHz.....	32
7.4.3	Interference mechanisms relevant for “Alternative C” within 2500 – 2690 MHz.....	34
7.4.4	RF Performance requirements for supporting “Alternative C” within 2500 – 2690 MHz.....	35
7.4.5	Summary.....	38
8	Feasibility of UTRA TDD in the band 2500-2690 MHz	38
8.1	Introduction.....	38
8.2	New Aspects regarding TDD operation in the band 2500-2690 MHz compared to the UTRA TDD core band.....	39
8.3	Enabling technologies.....	40
8.4	Requirements for updating 3GPP specifications	40
8.4.1	Physical layer of the radio interface (RAN WG1).....	40
8.4.2	Radio interface architecture and protocols (RAN WG2)	40
8.4.2.1	UE Radio Access capabilities	40
8.4.3	Overall UTRAN architecture and protocols of the Iu interfaces (RAN WG3).....	41
8.4.4	Frequency bands and RF parameters (RAN WG4)	41
8.4.4.1	Frequency bands.....	41
8.4.4.2	RF parameter.....	41
8.4.4.3	Relevant Interference mechanisms for use of UTRA TDD within the band 2500 – 2690 MHz	42
8.4.4.3.1	General.....	42
8.4.4.3.2	Node B – Node B Interference mechanisms in the band 2500-2690 MHz.....	42
8.4.4.3.3	UE – UE related Interference mechanisms in the band 2500-2690 MHz.....	42
8.4.4.4	Specific RF performance requirements to support deployment of UTRA TDD within the band 2500 – 2690 MHz	43
8.4.4.4.1	General.....	43
8.4.4.4.2	Support for unsynchronised TDD in case of BS - BS co-location	44
8.4.4.4.3	Support for unsynchronised TDD BS – BS co-existence within the same geographical area.....	45
8.4.4.4.4	Support for unsynchronised TDD UE–UE co-existence within the same geographical area.....	45
8.5	Summary.....	46
9	Conclusions	46
Annex A:	Impact of increased PL in the 2.5 GHz band on UTRA FDD UL/DL Cell Coverage	49
Annex B:	TDD UE-UE Interference Simulations.....	51
B.1	Introduction.....	51
B.2	Simulation Assumption.....	51
B.2.1	System scenario.....	51
B.2.1.1	Frequency allocation	51
B.2.1.2	Frame structure and timing between operators.....	51
B.2.1.3	Cell structure.....	52
B.2.1.4	UE distribution.....	52
B.2.2	Simulation parameters	52
B.2.3	Description of the propagation model	54
B.2.3.1	BS-to-UE and UE-to-BS propagation model	54
B.2.3.2	UE-to-UE propagation model	55
B.2.4	DCA	55
B.3	Simulation Procedure.....	55
B.4	Simulation results	56
B.5	Summary.....	57
B.6	Possible Future Study Areas.....	57
B.7	Reference	58

Annex C: Change history58

Foreword

This Technical Report has been produced by the 3rd Generation Partnership Project (3GPP).

The contents of the present document are subject to continuing work within the TSG and may change following formal TSG approval. Should the TSG modify the contents of the present document, it will be re-released by the TSG with an identifying change of release date and an increase in version number as follows:

Version x.y.z

where:

- x the first digit:
 - 1 presented to TSG for information;
 - 2 presented to TSG for approval;
 - 3 or greater indicates TSG approved document under change control.
- y the second digit is incremented for all changes of substance, i.e. technical enhancements, corrections, updates, etc.
- z the third digit is incremented when editorial only changes have been incorporated in the document.

Introduction

This clause is optional. If it exists, it is always the second unnumbered clause.

1 Scope

The present document summarises results from the Study Item “Feasibility Study considering the viable deployment of UTRA in additional and diverse spectrum arrangements”. Both UTRA FDD and UTRA TDD are considered. For UTRA FDD, the spectrum arrangements include the present FDD frequency bands as defined in Release 5 of the relevant 3GPP specifications as well as the additional bands identified for IMT-2000 by ITU-R WRC-2000, in particular the band 2500-2690 MHz. For UTRA TDD, the study focuses on the use of the additional band 2500-2690 MHz.

2 References

The following documents contain provisions which, through reference in this text, constitute provisions of the present document.

- References are either specific (identified by date of publication, edition number, version number, etc.) or non-specific.
- For a specific reference, subsequent revisions do not apply.
- For a non-specific reference, the latest version applies. In the case of a reference to a 3GPP document (including a GSM document), a non-specific reference implicitly refers to the latest version of that document *in the same Release as the present document*.

[<seq>] <doctype> <#>[([up to and including]{yyyy[-mm]}V<a[.b[.c]]>}[onwards]): "<Title>".

- [1] 3GPP TR 41.001: "GSM Release specifications".
- [2] 3GPP TR 21 912 (V3.1.0): "Example 2, using fixed text".
- [3] ITU-R 8F/623, “REPORT OF THE SEVENTH MEETING OF WORKING PARTY 8F (Queenstown, 27 February – 5 March 2002)”; ATTACHMENT 7.2, “Working document on preferred options for frequency arrangements for IMT-2000 systems in bands identified by WARC-92 and WRC-2000 (Revision to Att. 8.2 of Doc. 8F/489)”
- [4] 3GPP TS 25.331 v 3.9.0 (2001-12)“Radio Resource Control (RRC); Protocol Specification (Release 1999)”
- [5] R2-011087 Proposed CR 776 on Missing UARFCN uplink info, Nokia.
- [6] R2-011511 Approved Report of the 21st TSG-RAN WG2 meeting, Secretary.
- [7] 3GPP TS 25.101 v 3.9.0 (2001-12) “UE Radio Transmission and Reception (FDD) (Release 1999)”
- [8] 3GPP TS 25.104 v 3.9.0 (2001-12) “UTRA (BS) FDD; Radio transmission and Reception (Release 1999)”
- [9] 3GPP TR 25.931 V3.6.0 (2002-03), “3rd Generation Partnership Project; Technical Specification Group RAN; UTRAN Functions, Examples on Signalling Procedures (Release 1999).
- [10] UMTS Forum Report #9: “The UMTS Third Generation Market – Structuring the Service Revenues Opportunities”
- [11] UMTS Forum Report #13: “The UMTS Third Generation Market – Phase II, Structuring the Service Revenues Opportunities”
- [12] SAG 34/4, 12-14 Sept 2001
- [13] SAG 35/2, 3-5 Dec 2001
- [14] UMTS Forum SAG Doc SAG 36/3, 11-12 April 2002

- [15] Holma, Toskala, "WCDMA for UMTS", Wiley
- [16] Wacker, Laiho, Novosad, "Radio Network Planning and Optimisation for UMTS", Wiley
- [17] ITU-R 8/112-E; 17 October 2002.
DRAFT REVISION OF RECOMMENDATION ITU-R M.1036-1;
Frequency arrangements for implementation of the terrestrial component of International Mobile Telecommunications-2000 (IMT-2000) in the bands 806-960 MHz, 1 710-2 025 MHz, 2 110-2 200 MHz and 2 500-2 690 MHz.
- [18] Document 8F/TEMP/262; "Working document on preferred options for frequency arrangements for IMT-2000 systems in bands identified by WARC-92 and WRC-2000"
- [19] 3GPP TS 25.102: "UE Radio Transmission and Reception (TDD)".
- [20] 3GPP TS 25.105: "Base Station (BS) radio transmission and reception (TDD)".
- [21] 3GPP TS 25.306: "UE Radio Access capabilities".
- [22] 3GPP TS 25.307: "Requirements on UEs supporting a Release Independent Frequency Band".
- [23] 3GPP TR 25.942: "Radio Frequency (RF) system scenarios".
- [24] 3GPP TR 25.952: "TDD Base Station Classification".
- [25] R4-99640: "UTRA FDD to FDD Inter-frequency handover as an escape mechanism"; 3GPP TSG RAN WG4 #8, Nokia

3 Definitions, symbols and abbreviations

Delete from the above heading those words which are not applicable.

Subclause numbering depends on applicability and should be renumbered accordingly.

3.1 Definitions

For the purposes of the present document, the [following] terms and definitions [given in ... and the following] apply.

Definition format

<defined term>: <definition>.

example: text used to clarify abstract rules by applying them literally.

3.2 Symbols

For the purposes of the present document, the following symbols apply:

Symbol format

<symbol> <Explanation>

3.3 Abbreviations

For the purposes of the present document, the following abbreviations apply:

Abbreviation format

<ACRONYM> <Explanation>

4 Background and Introduction

The present 3GPP specifications cover the IMT-2000 2 GHz band (Band I and II), in accordance with ITU-R Radio Regulations Article S5 Footnote S5.388, in R99 and Rel4 and the work is continuing with the UMTS1900 Band II improvements and UMTS 1800 Band III.

ITU-R WRC-2000 identified additional extension bands for IMT-2000 that requires further studies for the subsequent future deployment of UTRA in the whole or parts of the bands as indicated below:

- 806 - 960 MHz (The whole band 806 - 960 MHz is not identified on a global basis for IMT-2000 due to variation in the primary Mobile Service allocation across the three ITU Regions)
- 1710 - 1885 MHz, where the work is progressing under UMTS1800 WI.
- 2500 - 2690 MHz (In ITU Region 1 the bands 2500 - 2520 MHz and 2670 - 2690 MHz is also allocated on a co-primary basis to the Mobile Satellite Service subject to market demand)

4.1 Scope and Objective of work

4.1.1 General considerations

The viable deployment of both UTRA modes FDD and TDD in additional and diverse spectrum arrangements should be assessed. Due to the difference in their duplex scheme, these modes have unequal intrinsic characteristics. It seems therefore appropriate to treat both UTRA modes separately from each other.

For the purpose of this feasibility study, it is assumed that additional spectrum, and in particular the frequency band 2500-2690 MHz, will be used exclusively by either UTRA FDD or UTRA TDD, respectively. Thus, co-existence between UTRA FDD and UTRA TDD is not considered, and corresponding compatibility studies between these modes are not considered in this report. It is however acknowledged that the combination of FDD and TDD in new bands is a valid option, as already discussed in ITU-R WP 8F.

Several different scenarios are possible of which seven are shown in the figure below, as taken from [17].

6.1.4.3 Scenarios for the Band 2 500 – 2690 MHz			
MHz	2500		2690
Scenario 1	FDD UL (internal)	↔ TDD ↔	FDD DL (internal)
Scenario 2	FDD UL (internal)	↔ FDD DL (external) ↔	FDD DL (internal)
Scenario 3	FDD UL (internal)	↔ TDD ↔	↔ FDD DL (external) ↔ FDD DL (internal)
Scenario 4	↔ FDD DL (external) ↔		TDD
Scenario 5	TDD		↔ FDD DL (external) ↔
Scenario 6	TDD		
Scenario 7	FDD DL (external)		

4.1.2 UTRA FDD

In case of UTRA FDD, the assessment includes

- Duplex spacing arrangements other than for Bands I, II and III.
- Arbitrary selectable or variable duplex spacing methods.

- Use of asymmetric spectrum arrangements considering the need for additional downlink traffic capacity
- Impacts on equipment performance requirements due to new frequency bands and operating bandwidths.
- Terminal capabilities and signalling
- Possible interface impacts

Spectrum bands to study in an initial phase are

Present bands:

- 1920 - 1980 MHz paired with 2110 – 2170 MHz Band I (core band)
- 1850 - 1910 MHz paired with 1930 – 1990 MHz Band II (PCS1900 band)
- 1710 - 1785 MHz paired with 1805 – 1880 MHz Band III (GSM1800 band)

Implementations to study for new bands and combinations of bands:

- 1) 1710 - 1770 MHz paired with 2110 - 2170 MHz
- 2a) 1710 - 1800 MHz paired with 2110 - 2200 MHz
- 2b) 1920 - 2010 MHz paired with 2110 - 2200 MHz
- 3) 1755 - [1805] MHz paired with 2110 - [2160] MHz
- 4) 1710 - [1755] MHz paired with 1805 – [1850] MHz
- 5) 2500 - 2690 MHz:

(Alt A) Entire band as additional DL to other bands used for technologies within scope & objective of 3GPP.

(Alt B) DL and UL in this band.

(Alt C) DL and UL in this band, and additional DL to other bands used for technologies within scope & objective of 3GPP.

The technology study should describe a possible technical implementation of a Variable Duplex technology (VDT) solution to satisfy the addressed new spectrum arrangements but also considering the existing spectrum arrangements. Enabling technologies for operating of UTRA FDD in the new bands are examined in clause 6. Examples for viable implementations of spectrum arrangements for UTRA FDD are described in clause 7.

4.1.3 UTRA TDD

In case of UTRA TDD, the same frequency channel is used sequentially for transmission in the uplink and downlink direction. Therefore, the duplex arrangement is independent of the spectrum arrangement. Other technical issues and assessments to consider are:

- Impacts on equipment performance requirements due to new frequency bands and operating bandwidths.
- Terminal capabilities and signalling.
- Possible interface impacts.

4.1.4 Caveat/Notice

The information in this TR is partly based on text from RAN4 meeting documents that also contained information in areas outside of the RAN4 mandate. Examples are paragraphs containing information on how the split of uplink versus downlink traffic will develop with time, as well as suggestions on how to develop a specification assuming certain decisions are taken in e.g. regulatory bodies on how the new spectrum is to be used. As this information is useful in helping understanding of the technical feasibility assessment and related conclusions in these sections, this information has been kept. RAN4 has refrained from discussing the text parts outside of its mandate for this TR, and thus conclusions should not be drawn from these parts.

The part related to the technical feasibility, and especially the text in the conclusion clause, have been agreed by RAN WG4.

5 Description of the spectrum arrangements

Document 8F/623 [3] lists several options for paired and unpaired frequency arrangements for IMT-2000 systems in bands identified by WARC-92 and WRC-2000.

For UTRA FDD, the options for paired frequency arrangements are applicable. Table 1 provides a selection of these options and additionally proposes some further opportunities based on VDT.

Table 1: FDD Frequency Arrangements

Arrangements	UE Tx (MHz)	Duplex Centre Gap (MHz)	BS Tx (MHz)	Duplex separation (MHz)	Remarks
Band I	1920 - 1980	130	2110 - 2170	190	Option 1 in 6.1.2 and [3]
Band II	1850 - 1910	20	1930 - 1990	80	Option 3 in 6.1.2 and [3]
Band III	1710 - 1785	20	1805 - 1880	95	Option 2 in 6.1.2 and [3]
(*)	1710 - 1755	50	1805 - 1850	95	
(*)	1755 - 1805	305	2110 - 2160	355	Option 4 in 6.1.2 and [3]
(*)	1710 - 1770	240	2110 - 2170	400	Option 5 in 6.1.2 and [3]
(*)	1920 - 1980	520	2500 - 2690	Variable	
(*)	1850 - 1910	590	2500 - 2690	Variable	
(*)	1710 - 1785	715	2500 - 2690	Variable	
(*)	1710 - 1770	730	2500 - 2690	Variable	
(**)	2500 (2520) - x	$y \geq 20$	$z - (2670) 2690$	Variable	x, y and z to be defined
(**)	$z - (2670) 2690$	$y \geq 20$	2500 (2520) - x	Variable	x, y and z to be defined. (Reversed duplex direction)

Note 1: Combination of Bands (*) and Bands (**) may be required to be considered in the future work.

Note 2: ITU-R Resolution 225 from the World Radio Communication Conference 2000 (WRC-2000) states that the bands 2500 - 2520 MHz and 2670 - 2690 MHz (as identified for IMT-2000 in the footnote S5.384A of the RR, and allocated to the mobile-satellite service (MSS)) may be used for the satellite component of IMT-2000. However, depending on market developments it may be possible in the longer term for bands 2500 - 2520 MHz and 2670 - 2690 MHz to be used by the terrestrial component of IMT-2000.

For UTRA TDD, the options for unpaired frequency arrangements are applicable. For the purpose of the present study, however, the only option of consideration is the use of UTRA TDD in the new band 2500-2690 MHz.

Although some of the general trends of traffic and spectrum development may be understood, there is still considerable uncertainty on the detailed market development. Therefore, regulators will decide on the use of additional spectrum for UMTS not until actual market demand will become clearer. CEPT ECC, for example, has stated in its Draft Decision on the designation of frequency band 2500 - 2690 MHz for UMTS/IMT-2000 [ECC/DEC/(02)FF], that the "detailed spectrum arrangements for the band 2500-2690 MHz will be decided by the end of year 2004". Furthermore, the draft states that "the frequency band 2500 - 2690 MHz should be made available for use by UMTS/IMT-2000 systems by 1 January 2008, subject to market demand and national licensing schemes".

6 Enabling technologies for operation of UTRA FDD in the new bands

6.1 Solutions for implementing variable duplex separation in one terminal

Enabling terminals to operate with a variable duplex separation will facilitate roaming between different countries or regions. In addition, for operators with multiple band pairings, such terminals will be able to handoff from one band to another.

It is to be noted that, at this stage, the variable duplex separation may be understood as a variable duplex separation on a frequency block basis or a variable duplex separation on a frequency channel basis. Both are already supported by channel numbering and frequency band concept in 3GPP specifications. There are aspects on signalling and control of the UE, and hardware impact, which are shown in the following sub-chapters.

6.1.1 Status in 3GPP specifications for accommodating variable duplex separation in one terminal

Several technical specifications allow the possibility of accommodating variable duplex separation in one terminal. Mainly affected are the specifications in RAN WG2 regarding the signalling and RAN WG4 regarding the Radio Transmission and Reception, but also test specifications in TSG-T1.

6.1.1.1 Signalling and control of the UE (RAN2)

Affected specifications in RAN WG2 are TS 25.306 and TS 25.331. TS 25.306 specify the UE capabilities, which includes supported frequency bands and Tx/Rx frequency separation. TS 25.331 specify the UE signalling and some UE behaviour related to random access and utilisation of the common channels. For the signalling two main cases are seen; signalling related to a UE using common channels and signalling related to a UE using dedicated channels.

6.1.1.1.1 Common channel aspects

In Rel'99, Rel-4 and Rel-5 when a UE sends its first access to a UMTS network, the UE will after it has found a cell on a certain downlink frequency, read the system information sent in that cell. This system information will give the channel parameters for the uplink random access channel in system information block (SIB) number 5 (see TS 25.331 [4] section 8.1.1.6.5). SIB 5 contain all configuration for common channels, both uplink and downlink. It should be noted that uplink frequency or duplex spacing is not included in the random access channel parameters. The UE will then send an access attempt on an uplink frequency that is according to the default duplex of the downlink frequency that the UE have selected and have been using to read system information (see TS 25.331 [4] section 8.5.17). This means that for 2100 MHz the uplink frequency will be 190 MHz below the downlink, for 1900 MHz the uplink will be 80 MHz below the downlink and for 1800 the uplink will be 95 MHz below the downlink.

Since a Rel'99, Rel-4 and Rel-5 UE always assumes that the uplink frequency is according to the default duplex distance, there is a risk that the UE transmits on an uplink frequency that is erroneous according to the assigned band. This could be a problem in option 1, 2a and 3 according to section 4.1 if default duplex is used or in any option (including also the core band) if the network only supports a non default duplex. Solutions to this potential problem were discussed at 3GPP RAN2 meeting #21 related to document R2-011087 [5]. The discussions are captured in the minutes in R2-011511 [6].

The solution that was discussed could in short be described as; that SIB 5 should only be used in networks where the default duplex distance is used and with the 2100, 1900 or 1800 MHz bands . In a network where another duplex distance or a new band allocation is used, a new SIB 5 should be introduced, "SIB 5 bis". This "SIB 5 bis" should be sent instead of the Rel'99, Rel-4 or Rel-5 SIB 5 and may then also contain the uplink frequency or an indication of the non default duplex distance.

According to the current specifications a Rel'99, Rel-4 or Rel-5 UE that enters a network (e.g. cell) that do not send SIB 5 will be barred from access (see TS 25.331 [4] section 8.1.1.5). The UE will not be able to transmit on the uplink neither for normal access nor emergency calls. This is also the desired behaviour since, the UE do not have the correct frequency support .

The result of sending "SIB 5 bis" will be that only UEs that understand this new SIB and have the correct frequency support can access that network. This could be captured in a future Release of the 3GPP specifications when the new frequency bands or duplex distances are introduced for common channels.

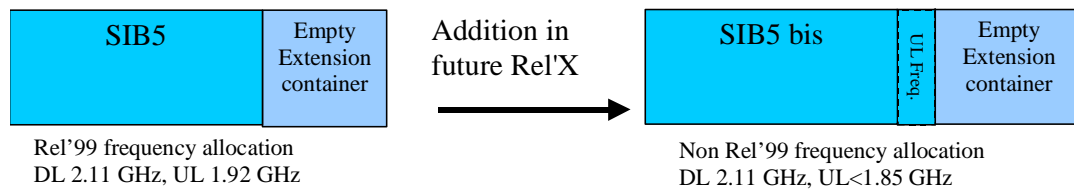

Figure 1. Possible solution in RAN2 specifications for accommodating several band pairings in one terminal.

6.1.1.1.2 Dedicated channel aspects

For dedicated channels UTRAN is in control of what frequencies the UE shall use, both for uplink and downlink. When the UE is moved from one frequency to another, signalling includes the downlink frequency and in case a non default duplex is to be used also the uplink frequency is included (see TS 25.331 [4] section 10.3.6.36). This means that the current Rel'99, Rel-4 and Rel-5 specifications support variable duplex distance or any of the new frequency allocations described in section 4.

However, in order for UTRAN to only signal a frequency allocation that is supported by the UE, capabilities need to be extended with new frequency bands and duplex spacing configurations.

6.1.1.1.3 UE capability aspects

The RF capabilities are specified in TS 25.306. These UE capabilities are sent to UTRAN during the initial RRC signalling. Alternatively if the UE does an access via e.g. GSM the capabilities are sent over the GSM air interface and transferred to UTRAN at the GSM to UMTS handover in a network container.

The RF capabilities are necessary for UTRAN to be able to know in advance which bands and duplex spacing that the UE supports prior to assignment of frequencies on a dedicated channel.

In Rel'99 and Rel-4 signalling specifications the UE is able to indicate support of the core bands 2100 MHz and the additional band 1900 MHz. It is also possible to indicate a duplex distance support that is only the default 190 MHz, 174.8 to 205.2 MHz or 134.8 to 245.2 MHz.

In Rel-5 signalling specifications the UE is able to indicate support of the 2100, 1900 and 1800 MHz bands.

In addition, a UE that is of one release (Rel'99 or Rel-4) can indicate support of additional frequency bands as specified in 25.307 "Requirements on UEs supporting a Release Independent Frequency Band" for that release. So with this addition it is possible for a Rel'99 or Rel-4 UE to also indicate support of the 1800 MHz band (or if extended any new future bands).

6.1.1.1.4 Signalling summary

The following table summarises the status on signalling support in the Rel'99, Rel-4 and Rel-5 specifications for the existing bands.

Table 2: Summary of signalling aspects for existing bands

Signalling aspect	Band I (2100 MHz)	Band II (1900 MHz)	Band III (1800 MHz)
Common channels Rel'99, Rel-4, Rel-5	Duplex distance = 190 MHz	Duplex distance = 80 MHz	Duplex distance = 95 MHz
Common channels with a SIB 5 bis	Duplex distance flexible	Duplex distance flexible	Duplex distance flexible
Dedicated channels Rel'99, Rel-4, Rel-5	Duplex distance flexible	Duplex distance flexible	Duplex distance flexible
UE Capability Rel'99, Rel-4	Signalling supported	Signalling supported (Note 1)	Signalling supported only with additions according to TS 25.307 (Note 1)
UE Capability Rel-5	Signalling supported	Signalling supported (Note 1)	Signalling supported (Note 1)

Note 1. Signalling is currently not complete when it comes to signalling of degree of UE support of variable Tx/Rx frequency separation for 1800 and 1900.

6.1.1.2 Frequency bands and hardware issues (RAN4)

6.1.1.2.1 Frequency bands

In TS 25.101 [7] (see section 5.3) the TX-RX frequency separation is specified for fixed separation of 190 MHz and 80 MHz depending on the frequency band. Further it states that UTRA/FDD can support both fixed and variable transmit to receive frequency separation. And it also states that the use of other transmit to receive frequency separations in existing or other frequency bands shall not be precluded. Similar text can be found in TS 25.104 [8] regarding the Base Station.

When other frequency arrangements are introduced in 3GPP this section would be updated to list the TX-RX frequency separation for those frequency arrangements. Depending on the frequency arrangements there would also be other additions to RAN WG4 specifications, including that section 5.2 in 3GPP TS 25.101 [7] would be expanded by the relevant frequency bands.

The number of bands implemented in the UE is left to the manufacturers in agreement with operator partners.

6.1.1.2.2 RF performance

The impact to RF performance, firstly sensitivity, transmitter power and current drain, and secondly additional interference requirements, may require a change in the specifications. The variety of band combinations and the need for non-compressed as well as compressed mode terminals leads to a high number of possibilities that must be taken into account. It must be considered that RF performance specifications may be negatively affected, especially as the complexity in modes/bands increases.

It is therefore recommended to further study Rx and Tx RF performance before specifications can be finalised for UEs supporting multiple duplex spacings.

6.1.2 Examples of Implementation of variable duplex separation in one terminal

The Table 1 in chapter 5 lists several band pairing options in 1710 – 2200 MHz.

The UMTS core band is according to option 1 with 190 MHz fixed duplex separation as specified in 3GPP. Since not all options will be available in every region there will be a need to support more than one option in one terminal if global roaming is envisaged. Based on the assumption that the UMTS core band will be used in several regions and will be available first on the market, one scenario is to combine option 1 with one or several other options. The following scenarios have been chosen for further evaluation:

- Options 1 + 5 (+4)
- Options 1 + 2

The combination Options 1 + 3 has similar design impacts as Options 1 + 2.

Any of the proposed additional bands to the existing UMTS core band (Option 1) will require variable duplex separation. The simplest configuration to consider is Option 1 + Option 5 configured in a compressed mode with DCS1800 or PCS1900.

- Options 1+5 (+4):

Adding Option 5 leaves the core RX band (Option 1) untouched, so the complete receiver can be reused. The added TX band is at a larger duplex gap making it potentially relatively straightforward to implement. An example of a compressed mode implementation is shown in Figure 2. The duplex filter in Figure 2 is a new component, but it is assumed it can be based on existing technology.

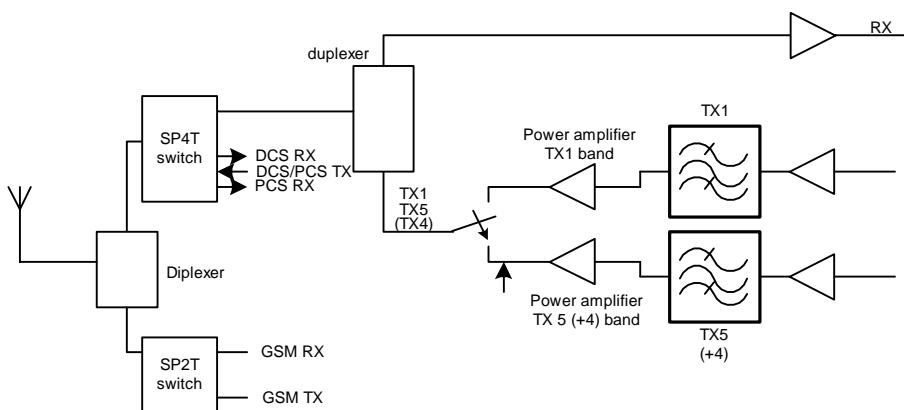

Figure 2. Example of compressed mode implementation for Option 1+5.

In Figure 3, another example of a compressed mode implementation is shown, which is more readily realizable, as multiple RF filters are used instead of one single duplexer.

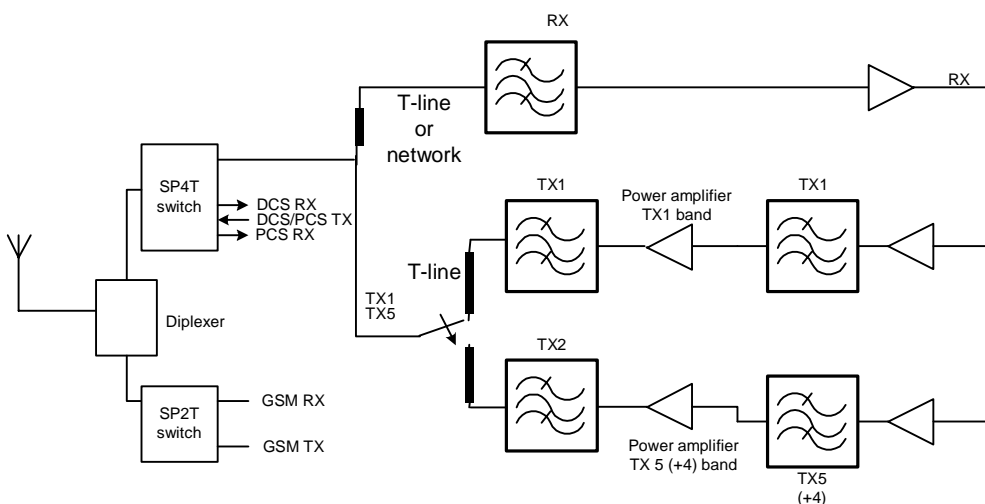

Figure 3. Example of compressed mode implementation for Option 1+5.

Having an additional duplex mode results in additional losses to both the Tx and Rx sides of the WCDMA system. As the number of bands increases, the losses can be expected to increase even more. Furthermore if a non-compressed mode implementation is chosen for associating DCS1800 or PCS1900 to WCDMA, then the losses are likely to be even more important. In any case, these losses are likely to be bounded by [2] dB on either Tx or Rx side. Further studies are needed so as to clearly evaluate the additional losses induced before specifications can be finalised.

- Options 1+2:

As duplexers and duplexers are carefully designed for specific frequencies, a classical implementation is to have one duplexer for each band pairing supported by the terminal. This combination will thus require 2 duplexers with very different requirements. Two complete receivers are needed for this combination. The general transceiver requirements from GSM 1800 are different, so reuse of GSM 1800 RF components for UMTS on 1800 is not possible. Further studies are needed before specifications can be finalised.

Note: The coexistence of Option 2 with the PCS1900 band is an open issue. The closeness of the bands will further complicate the RF filter requirements and/or require large guard bands.

6.1.3 VDT Conclusion

Having terminals able to operate over several band pairings will facilitate roaming and will also enable operators to provide service in multiple bands. Any vendor-specific implementation is suitable as long as RF performance are carefully studied and specified. A choice is to be made between having the terminals implementing variable duplex separation on a frequency block basis or on a frequency channel basis. It is however recommended not to have this variable duplex spacing capability mandatory in terminals.

6.2 Solutions for having a terminal accommodating frequency band asymmetry

Chapter 4.1.2 introduces three alternatives for using the band 2500-2690 MHz for FDD. Alternative A assumes that the band is used as an additional downlink to other paired bands . Chapter 7.1 contains a description and discussion on how to use the band 2500 – 2690 MHz in conjunction with operation of UTRA FDD within the 1920 - 1980 / 2110 – 2170 Band I (UTRA FDD core band).

Adding the receiver band 2500-2690 MHz in the terminal leaves the core TX band (Option 1) untouched, so the complete transmitter can be reused. The added RX band is at a much larger duplex gap making it potentially relatively straightforward to implement. An example of an implementation where it is possible to select between the receiver bands is shown in Figure 4. This solution is based on the same concept as in Fig. 3.

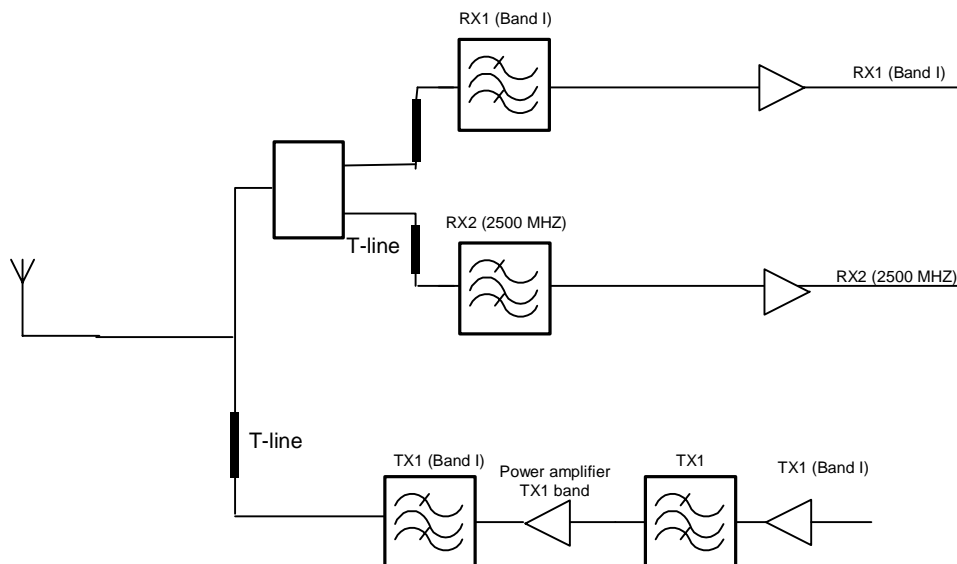

Figure 4. Example of UE using the combination of the 1920 - 1980 / 2110 – 2170 Band I UL/DL and the 2500-2690 MHz band DL.

7 Examples for viable implementations of spectrum arrangements for UTRA FDD

Table 1 in chapter 5 list several band pairing options in the 1710 – 2200 MHz range. The implementation aspects of these were treated in chapter 6. The usage and implementation of the band 2500 – 2690 MHz will be discussed further in this chapter 7. And additional use of VDT for deployment for public indoor systems is shown in chapter 7.2.

7.1 DL usage of the new band 2500 – 2690 MHz in conjunction with the Band I for UTRA FDD

This clause discusses the usage of the 2500 - 2690 MHz spectrum on the assumption that it is used for for UTRA FDD DL in conjunction with an assumed operation of UTRA FDD within the 1920 - 1980 / 2110 – 2170 Band I (UTRA FDD core band). The following aspects shall be covered:

- Relevant radio network propagation and performance aspects for UL/DL operation within the 2.5 GHz band
- UTRA system requirements for efficiently supporting the 2500 – 2690 MHz band for asymmetric DL operation
- Required changes of current UTRA specifications in order to support efficient operation within the 2.5 GHz band

7.1.1 Radio Network Performance Aspects regarding utilization of the 2500 – 2690 MHz Band

In this clause we consider propagation and radio performance aspects related to the UTRA operating efficiency in the 2.1, respective, 2.5 GHz bands.

7.1.1.1 Relevant Propagation Aspects for 2.5 GHz Band

There are no significant differences in the basic physical mechanisms of radio propagation in 2.5 GHz compared with 2 GHz. All effects (PL, diffraction losses, building/wall penetration losses, etc) are understood to scale as a continuous function of frequency and thus the basic modeling assumptions concerning radio propagation developed for the 2 GHz band can be re-used without much loss of accuracy.

However, and this is significant for the following discussion, there will be a larger path loss (PL) for the 2.5 GHz bands compared to the 2 GHz . Assuming that the Okumura-Hata (OH) model (see e.g. [5]) is still valid around 2.5 GHz, we can estimate the additional PL from the frequency dependent term in the OH model, $B \cdot \log_{10}(f)$, where $B = 33.9$ ¹:

$$\Delta PL = B \cdot \log_{10}(2.5 / 2.1) = 2.57 \text{ dB}$$

Compared to operation in the 2 GHz bands, also additional cable losses for the 2.5 GHz signal relative to the one around 2 GHz will occur at Node B sites - these are typically in the order of 1 ... 3 dB/100 m, depending on the cable type and size. Thus, for cable length of up to 20 m (typical for rooftop installations) the additional cable losses in 2.5 GHz will be in the order of 0.3 ... 0.6 dB – these are the values used in the following calculations.

7.1.1.2 Impact of increased PL in the 2.5 GHz band on UTRA UL/DL Cell Coverage

Currently deployed urban UMTS cells are frequently co-sited with existing GSM cells and are typically designed for a coverage target on UL of about 64 – 144 kbps data and for DL of up to 384 kbps data, thus matching the GSM cell footprint with typical PLs of some 150 – 155 dB. Typically an UL load factor of 0.3 ... 0.6 is assumed resulting in an equivalent noise rise of some 1.5 ... 4 dB. For DL larger load factors of up to 0.8 are frequently assumed. Under these (typical) conditions *the UTRA UL becomes coverage and the DL capacity (or interference) limited*, for a more detailed discussion see e.g. references [15,16].

¹ This value for B is expected to be larger for 2.5 GHz, thus in here we may underestimate the increase of the PL compared to 2.1 GHz

It is important to note now that the increased PL in the 2.5 GHz band of approximately 3 dB effects the UTRA UL/DL cell coverage limitations. In fact, an additional PL will not affect *an interference limited link* such as the UTRA DL typically is. However, the UTRA coverage limited UL (data coverage being essentially limited by the limited UE Tx power) would be adversely affected by the increased PL if deployed within the new 2.5 GHz band. In order to retain the same cell coverage as in the 2 GHz Band I, additional and costly means to recover this 3 dB PL loss would need to be deployed (e.g. UE with higher power class, smart antenna solutions in Node B, etc).

A more detailed case study analysis has been conducted to illustrate this dynamics and the results are presented in Appendix A. When introducing additional carriers in the 2.5 GHz band to share the DL traffic with the Band I carriers the following observations can be made (see also to Fig.1 in the Appendix A):

- at each DL throughput point, the fractional DL load value is equal for 2.1 / 2.5 GHz carriers, in particular for the pole capacity (DL load = 1). No DL capacity is lost due to the extra PL. This is a consequence from the fact that the DL load equation (see [15], p. 159) does *not* depend on the path loss.
- The introduction of each additional DL 2.5 GHz carrier adds the same DL capacity as a corresponding Band I carrier would do
- The introduction of each additional DL 2.5 GHz carriers increases the achievable DL / UL throughput asymmetry of the system
- There appears to be no need for power compensating the additional 3 dB PL on the 2.5 GHz carrier for *coverage reasons* as there is ample margin for DL coverage available
- As long as the DL / UL throughput asymmetry is high enough, the UL can carry the additional traffic to support the 2.5 GHz carrier with no adverse effect on the cell size / coverage
- Significant DL capacity gains (and thus the DL / UL throughput asymmetry ratios) could be effectively gained by introducing additional carriers in 2.5 GHz. The maximum achievable capacity asymmetry ratio is essentially limited by the amount of spectrum available for DL operation. E.g. the case of deploying the full 2500 – 2690 MHz band for DL operation a ratio of up to 4:1 for DL / UL throughput could be obtained for UTRA (now considering operation in 3G spectrum allocations only).

•

7.1.2 Towards an UTRA Standard for supporting DL optimised utilisation of the 2500 – 2690 MHz band

A number of conceptual UTRA system design decisions will need to be made, in order to establish detailed requirements for enhancing the (evolving) 3GPP standards to support DL optimised utilisation of the 2.5 GHz band. On a high level a number of system design issues have been identified, including but not limited to:

- How will the operation of DL physical channels / TrCHs on 2.5 GHz carriers be linked to those residing on UL Band I carriers ?
- What are the supported DL physical channels / TrCHs on 2.5 GHz carriers, in particular CCCHs ?
- What are the supported cell topologies / hierarchy (ie macro/micro/pico cells) when using 2.5 GHz DL carriers in addition to those within the Band I?
- Should a UE be prepared to use *simultaneously* or *alternatively* use a 2.5 GHz DL carrier with/to a DL carrier active in the Band I?
- Should a UE support the same RRC states and state transitions as in the current Band I standard as well in the 2.5 GHz band?
- What additional RRM measurements and RRC procedures are needed for extending existing IFHO mechanisms to include inter-band handovers (IBHO) between the core and 2.5 GHz bands?

7.1.2.1 Overall Objectives for UTRA 3GPP standards development to support DL optimised utilisation of the 2500 – 2690 MHz band

The following overall objectives may be taken into account when developing the 3GPP UTRA specifications for supporting DL optimised utilisation of the 2500 – 2690 MHz band:

- No or minimum restrictions in the utilization of services and features available from the (evolving) 3GPP UTRA Band I specifications, including those currently under development (such as e.g. HSDPA). There shall be full flexibility in locating services and features between the core and 2.5 GHz bands primarily limited by the basic capability of UE and Node B to operate in the 2500 – 2690 MHz band (in addition to the Band I).
- Reuse of all standard UTRA TrCH and physical channels in 2.5 GHz DL carriers, including those currently under development (such as e.g. HSDPA). The goal shall be that the required capabilities and mechanisms for UTRA to operate in the 2500 – 2690 MHz band are *orthogonal* to the features developed for the UTRA Band I specifications, in order to simplify UTRA standards development and minimise adverse affects from feature interactions.
- Possibility to implement the 2.5 GHz DL capability into UE and UTRAN Band I product families at low cost and with comparably small development effort. In particular, it shall be possible for the UE to retain low cost single-receiver architectures (as supported by today's Band I UTRA standard) also for the 2.5 GHz DL enhancement. This is seen as important to migrate mass-market data traffic into the 2.5 GHz band.
- Support for flexible range of achievable DL-UL traffic asymmetry, limited by the available spectrum (up to 1:4 ratio) only
- - No or minimal negative impact (other than the required traffic handling capacity) on the operation and performance of the utilized UL carriers in the Band I
- Smooth evolution of operational Band I UTRANs and operational and network planning practices when utilizing additional 2.5 GHz DL carriers. Adding a 2.5 GHz DL carriers to a deployed UTRAN should be an effort comparable to adding an additional carrier in the Band I.

7.1.2.2 Towards a technical framework for extending UTRA to support DL optimised utilisation of the 2500 – 2690 MHz band

The above overall objectives for development of the 3GPP UTRA standard for supporting DL optimised utilisation of the 2500 – 2690 MHz band can be met when making the following *technical working assumptions* the starting point for further concept development:

- 1) Each additional 2.5 GHz DL carrier should be seen simply as an additional “other-frequency layer” for DL capacity addition, *matched* to one of the corresponding layers already existing within the Band I. The additional layer(s) within the 2.5 GHz band could thus “mirror” either a macro, micro, or indoor/pico layer implemented in the Band I in a certain geographical area. This concept does *not* support eg a 2.5 GHz DL micro cell matched with a Band I macro cell UL², however, there could be a 2.5 GHz micro cell layer coverage-matched to a Band I micro cell layer. Mirroring an existing Band I UL/DL cell footprint/layer in 2.5 GHz, is the key for the simplicity in the areas of
 - Re-using to maximum extent existing UTRA procedures and mechanisms (cell reselection, IFHO, RRM measurements and control); minimal impact on the UTRA standard
 - Ease of radio network evolution; utilization of the additional 2.5 GHz cells is then building on known cell designs / concepts / cell coverage plans and operational practices already available within the Band I UTRAN
 -
- 2) VDT is utilized to flexibly pair a carrier within the 2.5 GHz band with a Band I UL carrier; this pairing can be determined by UTRAN based on e.g. UE capabilities, UL/DL load reasons, etc. The UE should not be required to receive at the same time the associated Band I DL carrier other than occasionally monitor eg the CPICH Ec/Io

² this is for following reason: for soft HO detection UL and DL cell coverage should be similar, in particular we should be able to derive the need for soft HO from the UL perspective (for interference avoidance) from measurements of CPICH Ec/Io measurements obtained from 2.5 GHz carriers

for inter-band HO (IBHO) purposes when instructed so by the UTRAN, in a similar fashion as UTRA currently manages IFHO procedures.

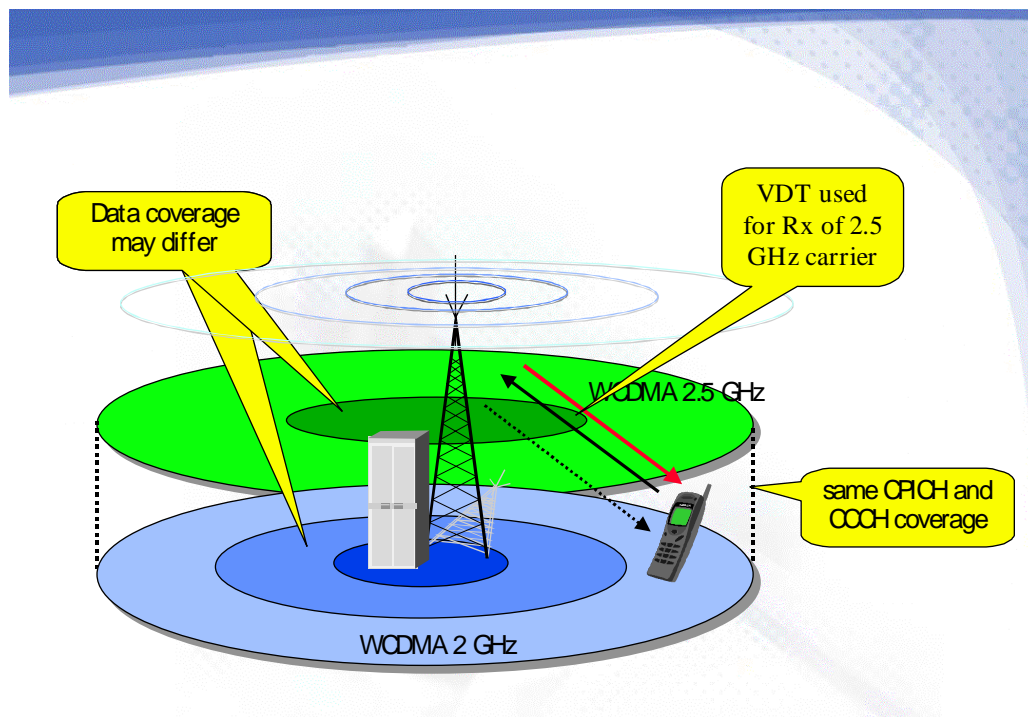

Figure 4

- 3) The DL 2.5 GHz DL coverage³ (for the various service bit rates) shall be the same as the coverage of the associated Band I DL. Thus also the Band I coverage of the used UL carrier will be matched and we are able to rely on all the standard UE RRM measurements (CPICH Ec/Io, RSCP, etc) for cell reselection and soft handover purposes.
- 4) It is assumed that all standard UTRA DL physical and TrCHs (CPICH, SCH, AICH, ...; BCH, PCH, FACH, DCH, DSCH, HS-DSCH, etc) can be made available within the 2.5 GHz carriers. Consequently, one is able able to offer
 - The same services and bit rates, whether RT or NRT
 - The same performance enhancing features (eg TxDiv, BF)
 as in the Band I. Also load sharing and trunking gains across the DL bands can be achieved according to the network operators needs.
- 5) UEs currently camped or active on 2.5 GHz carriers should be able to perform all RRC state transitions (e.g. Cell_FACH <-> cell_DCH) as would be the case on a Band I carrier. This again minimizes the need for additional procedures to distribute traffic between the bands and allows flexible UTRAN controlled distribution of the UE population during RRC connection setup.

The additional 2.5 GHz DL carriers shall be co-located with the associated matching UL / DL carriers within one node B. Thus, one can use all the standard UTRA fast L1 related processing (fast closed PC, any form of L1 related feedback signaling typically carried on DPCCHs) between UL-DL⁴. The philosophy is to treat the additional 2.5 GHz DL carrier just as any other additional Band I carrier, except for the obvious items related to the different carrier frequency.

³ here and in the following with *DL coverage* we mainly refer to the *CPICH Ec/Io* coverage, ie we don't assume the necessarily that the *user bit rate* coverage is the same between the bands. Thus it shall be feasible to offer in either DL band better data coverage than in the other (eg by deploying more efficient schemes such as HS-DSCH).

⁴ Otherwise there is either a large impact on 3GPP standard or one would need some RF-over-fiber type of concept for remote RF heads, however, then still all the DL BB processing would be in same Node B as the UL BB.

Certainly this list of technical assumptions is neither complete but an indication of the kind of items 3GPP would be required to study further.

7.1.3 Radio Resource Management (RRM) aspects with extension DL carriers in 2500 – 2690 MHz

7.1.3.1 UL interference scenario

The DL extension carriers in the 2.5 GHz band can be used on a cell-by-cell basis. DL capacity can be enhanced either for the whole layer mirroring the coverage of the associated core band carrier or for some hot spot areas. RRM procedures are applied the same way as in the core band bearing in mind that one UL carrier is associated with multiple DL carriers, i.e. one DL carrier in the core band and one or more in the extension band. Balancing of DL load as an example can therefore be achieved by an inter-band handover (UL, DL1 => UL, DL2) while balancing of UL load requires an inter-frequency (UL1, DL1 => UL2, DL2) or inter-system handover.

Intra-frequency measurements within the 2.5 GHz band e.g. for soft handover purposes are performed the same way as in the core band. At the coverage edge, however, a pre-emptive coverage reason handover is needed in order to avoid the risk of extensive UL interference to the intra-frequency neighbour(s) of the associated core cell. Since the coverage edge of the 2.5 GHz cell does not necessarily coincide with the border to the neighbour of the associated core cell as illustrated in the figure below, the pre-emptive coverage reason handover is likely to be required a bit earlier than it would occur by typical coverage triggers e.g. UL/DL power limitation. The area where UL interference can happen is somewhat the core band soft handover (SHO) area that is not mirrored in the 2.5 GHz band (i.e. some of the cells on the core band do not exist on the 2.5 GHz band).

In the following the term "SHO area" will be used to describe this geographical area of potential UL interference although the UE itself is not in SHO. Also, significant interference does not occur yet when the UE is just entering the core band SHO area but only when the core band neighbour becomes the strongest cell in the core band. For simplicity, we still use the term "SHO area" because the area of UL interference geographically strongly correlates with the SHO area in the core band that is un-mirrored in 2.5 GHz.

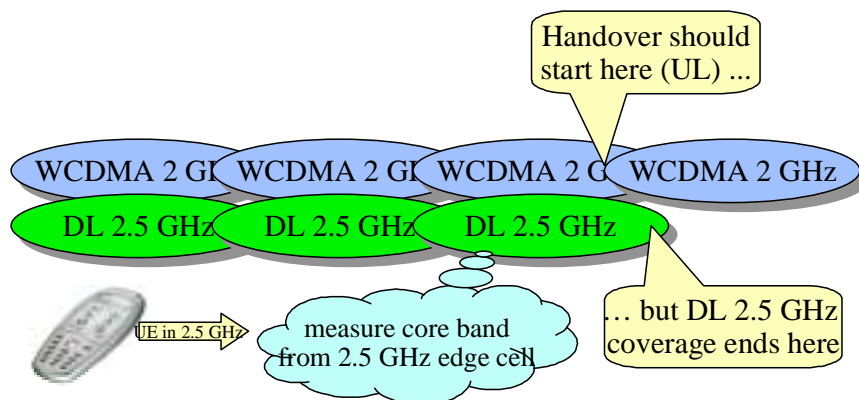

7.1.3.2 Interference detection and avoidance

With the current 3GPP measurements, the UE in the 2.5 GHz band cannot recognize when it is entering an UL interference area.

One way to solve this issue is to apply **tight coverage reason triggers** that enable the escape handover before the UE reaches the interference area. This is a valuable option for cells where the un-mirrored core band SHO area is far from the Node B location and thus tighter handover triggers will not extensively reduce the coverage of that cell.

In case the un-mirrored core band SHO area is relatively close to the Node B location - close in terms of pathloss - that cell would however have significant part of the coverage unused. Also, if it is as close as or even closer than other mirrored SHO areas (left hand side of the 2.5 GHz edge cell in the figure above), the SHO to other 2.5 GHz neighbours would not be possible. Instead an inter-band handover would take place even though not necessary. For those cells, an alternative method is provided by **additional core band measurements** to detect un-mirrored SHO areas in the

associated core band. As UL interference arises only in 2.5 GHz border cells also measurements can be limited to these cells.

In the following measurements in different RRC service states are considered. Although in principle UL interference does not occur in every RRC state, measurements are still recommended in all states to allow a fast transition between the states. This means that also measurements in idle mode are considered to avoid extensive delay during call initiation.

CELL_DCH

To minimize UE inter-band measurements in CELL_DCH state, core band measurements for interference area detection can be split into 2 steps

- (a) periodic RSSI measurements of the associated core carrier
- (b) event (i.e. need) based inter-band neighbour measurements of the core band neighbours using e.g. compressed mode

While (a) gives an indication of increased other cell interference when comparing it with the 2.5 GHz RSSI value, (b) verifies that the increased RSSI value is due to an un-mirrored core band neighbour. The first light measurement (a) should be on for all UEs all the time in that cell as in principle, SHO areas can be at any distance from the Node B location while the more extensive inter-band measurements (b) are triggered only for UEs close to the interference area. The split of core band measurements into 2 steps reduces UE measurement time, which furthermore reduces necessary compressed mode time.

Idle mode, CELL_PCH, URA_PCH

To allow camping in all 2.5 GHz cells without the risk of UL interference at RACH transmission, potential interference areas must be detected by inter-band measurements. In order to maintain reasonable activity in paging modes the measurements can be controlled by measurement rules and criteria, which are based on e.g. CPICH Ec/Io level. By comparing the 1:1 co-siting in both bands, the UE notices an un-mirrored SHO area in the core band and autonomously initiates a cell re-selection to the core band.

In cells with distant SHO areas, again tighter cell re-selection triggers are an alternative to the additional UE measurements. Then, cell re-selection will be initiated before the UE can enter the potential interference area.

CELL_FACH

In CELL_FACH state the UE can use the measurement occasions to perform interference area detection in the core band.

Interference avoidance

Interference is effectively avoided by an escape inter-band handover to the core band (pre-emptive coverage handover). In idle mode, CELL_FACH, CELL_PCH, and URA_PCH state, when entering an interference area the UE initiates cell re-selection to the core band to prevent UL interference at RACH transmission.

When camping in the core band, a directed RRC connection setup to the 2.5 GHz band must be avoided from an un-mirrored SHO area.

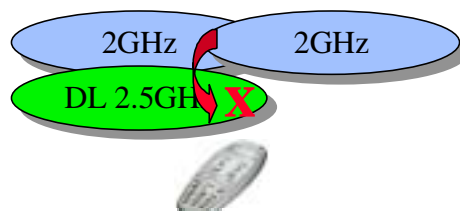

Compressed mode (CM) usage

Identifying the core band neighbours during CELL_DCH state requires compressed mode (CM) measurements or a dual-receiver in the terminal. The additional CM UE measurements replace CM measurements performed for the preparation of coverage reason handover. Considering the effect of CM usage on network capacity, which relates

directly to the number of mobiles simultaneously in CM, it can be expected that in total the effect is not likely to increase and it can even decrease due to the following facts.

- The interference escaping handover is pre-empting the coverage reason handover. So, additional UE measurements are replacing measurements to prepare coverage reason handovers. In addition, as co-sited DL carriers in the core and extension band are synchronized, CM measurements for inter-band handovers can be made more efficiently i.e. in shorter time by utilizing the synchronization information.
- The main load balancing in this concept can be achieved already at call setup by directing the RRC connection to another carrier. This does not require CM measurements at all. It almost completely substitutes load reason handovers and thus also CM measurements as preparation for load reason handovers.
- Inter-band handovers for any reason (service, load etc.) can utilise the synchronisation of the co-sited DLs. CM usage is required less if necessary at all for inter-band handovers.

7.1.4 Needed Additions to the UTRA Standard for supporting DL optimised utilisation of the 2500 – 2690 MHz band

It is perhaps premature to list the precise impact on the 3GPP UTRA specifications, before the overall system concept has been agreed and stabilized.

However, assuming the UTRAN support for DL optimised utilisation of the 2500 – 2690 MHz band would be build within the framework of Sect. 3.3, the most significant revisions are believed to be required for the following TSs:

TS 25.101 UE Radio Transmission and Reception (FDD)

UE RF requirements for 2.5 GHz band

TS 25.133 Requirements for Support of Radio Resource Management (FDD),

Additional RRM measurements for IBHO

TS 25.104 UTRA (BS) FDD; Base station Radio Transmission and Reception,

Node B RF requirements for 2.5 GHz band

TS 25.304 UE Procedures in Idle Mode,

Extending the cell selection/reselection procedures for to support the 2.5 GHz band

TS 25.331 Radio Resource Control (RRC) Protocol Specification,

“cleaning up” some of the missing parameters in RRC signalling required to fully utilize VDT, e.g. currently only fixed distance duplexing for UL/DL CCCHs is supported

As can be seen from the list, this SI will also impact other WG's than TSG RAN WG4 alone.

7.1.5 Summary of section 7.1 for usage of the new band in 2500 – 2690 MHz in conjunction with the Band I for UTRA

The section 7.1 has presented key system considerations and requirements for 3GPP UTRA standard development towards supporting DL optimised utilisation of the 2500 – 2690 MHz band with the goal to obtain a capacity enhancing complement for UTRA operating in the Band I.

The main findings presented in this section were:

-
- It appears feasible to augment the existing UTRA Band I standard in order to support DL optimised utilisation of the 2500 – 2690 MHz band with reasonable work effort effecting the specifications only in a few localized areas (RRM measurements, RRC procedures)

- Use of VDT is an essential technological element in providing this solution
- Such an enhanced UTRA standard would be able to offer a large degree of DL / UL traffic handling asymmetry at reasonable complexity and cost

7.2 Use of VDT for deployment of public indoor systems

7.2.1 Introduction to the scenario

Figure 5 below shows an example where an indoor system with general public access is deployed in a building within the coverage area of a macro site. When entering the building, handover is provided from the macro cell to the indoor system.

Indoor systems may be required also in the early deployment of WCDMA to improve indoor coverage and/or off-load the macro cells at local hot spots.

Spectrum is a scarce resource. Available spectrum is often needed to serve the wanted wide area traffic. Therefore the indoor cells will normally reuse all spectrum or parts of the spectrum used by the macro site.

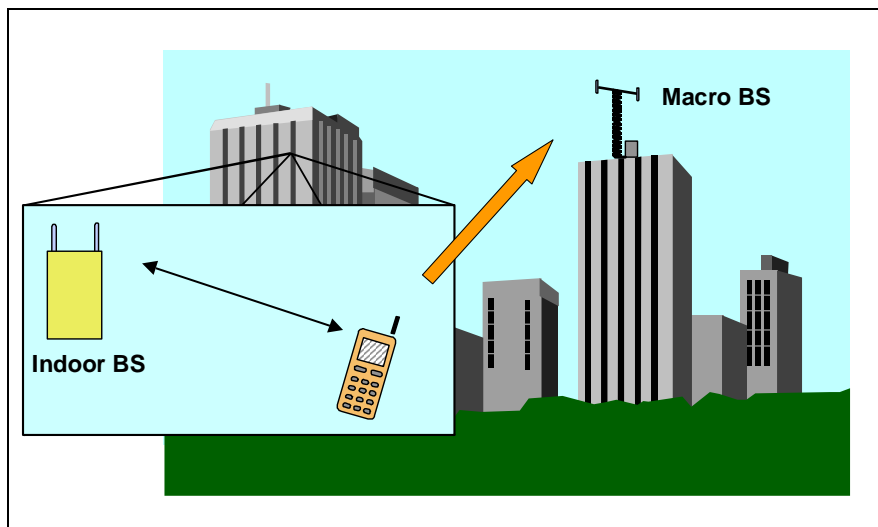

Figure 5: Indoor system for public access within the coverage area of a macro site.

7.2.2 Assumptions for the scenario

The example used in this report is operators with at least a 2x10 MHz license block, enabling 2 UTRA FDD carrier pairs.

For the indoor BSs, each operator will use at least one of the WCDMA carrier pairs that are used by the outdoor macro system, thus providing soft handover between the macro and indoor cells on this carrier. Indoor systems are expected to be mainly deployed in urban areas, but could be introduced also in hot spots surrounded by medium and low traffic areas (e.g. airports and shopping centres located outside of city centres). In an initial phase the deployment of WCDMA is expected to take place as macro sites for coverage, complemented by some limited indoor systems. When traffic increases within the area covered by the macro site, further deployment of indoor systems may be expected to further off-load the macro sites. Once indoor systems are installed, they will not only be able to off-load present indoor users from the macro site, but may manifold multiply the total traffic supported within the area covered by the macro site. Each indoor cell (each building or each floor of a building) is well isolated compared to outdoor macro cells. Therefore the capacity per carrier pair of each indoor cell will be equal to the macro site capacity per carrier pair, if the capacity is code limited, else it may be e.g. twice as high as for the macro site.

This above application of indoor cells is straightforward in non line-of-sight cases, but off-loading will be limited in indoor areas (floors) in line-of-sight from the macro site, since the macro site field strength is dominating there. Designing the indoor system for full off-loading in line-of-sight areas and additionally using the full indoor system

capacity in line-of-sight areas may cause increased up-link interference for the macro site. This interference can be eliminated by the use of Variable Duplex Technology.

A scenario without VDT is described in Table 2. The table indicates columns for areas with different average traffic densities from high to low. In each type of area there could be hot spots where an indoor system is beneficial. Dx and Uy are notations for downlink and up-link carriers. Dx-Ux indicates a coupled pair with the standard duplex separation (190 MHz for band I). The terminology Initial Phase means that providing coverage is most important. Carrier pairs within parenthesis indicate possible application, but the traffic requirements do not require any special measures to protect the macro cell from up-link interference. In the Second Phase traffic requirements increases also for indoor systems. This may lead to increased up-link interference to the macro site. See next section.

Table 2: Scenario without VDT. Dx-Ux are coupled Downlink/Uplink carrier pairs. Pairs in brackets are with limited or no traffic.

Phase	High traffic areas		Medium traffic areas		Low traffic areas		Comment
	Indoor Systems	Macro	Indoor Systems	Macro	Indoor Systems	Macro	
Initial	(D1-U1)	D1-U1 (D2-U2)	(D1-U1)	D1-U1	(D1-U1)	D1-U1	Coverage only. Mainly D1/U1.
Second	D1-U1	D1-U1 D2-U2	(D1-U1)	D1-U1	(D1-U1)	D1-U1	Traffic increases. Indoor Systems are introduced. D2/U2 is added.

7.2.3 UL interference from increased traffic in indoor system

When assessing the impact of additional up-link, UL, interference, it is important to note that the WCDMA macro site capacity normally is downlink, DL, limited for symmetric (speech) traffic. We could furthermore assume that there could substantial asymmetric (internet) traffic as well. This would make the WCDMA capacity even more DL limited when using a symmetric DL/UL spectrum allocation. Thus we could assume that the macro site could stand additional interference on the UL before the macro site capacity is affected.

In the example of Figure 6 below we assume that the macro base station UL could be degraded to about 2/3 of its available capacity before the macro cell capacity is degraded. The figure indicates how the macro site will have full U1 capacity, but when the indoor traffic increases, the U1 capacity in the same macro site may be reduced due to interference. The U1 capacity may for this example be reduced to 1/3 before the macro cell capacity is affected.

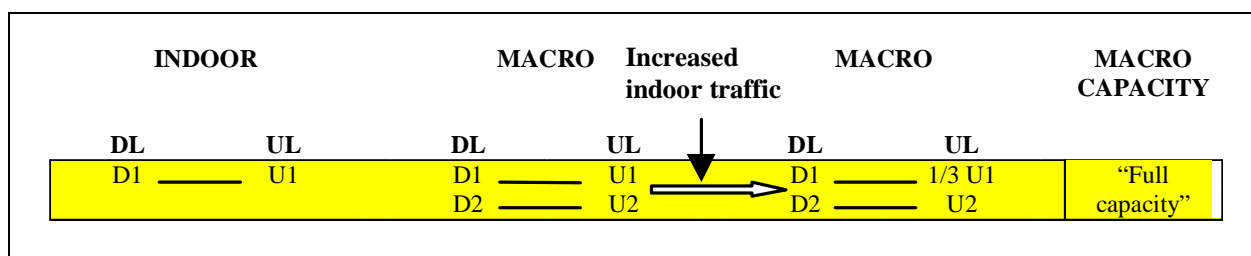

Figure 6: Indoor system for public access within the coverage area of a macro site.

When continuously increased Indoor System traffic degrades the macro cell UL capacity below e.g. 1/3 UL capacity, the remaining U1 capacity may be very small. This is indicated in Figure 7 below. The D1-U1 carrier pair cannot carry much traffic any longer, and the resulting total macro cell capacity may approach 1/2 of its original capacity (in case of two carrier pairs).

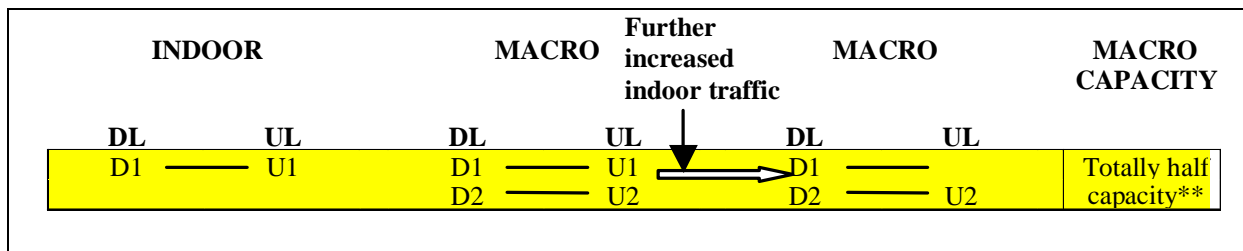

Figure 7: Indoor system for public access within the coverage area of a macro site.

7.2.4 Controlling the UL interference with the use of VDT

A suggested migration path to full utilization of both Indoor Systems and macro cell traffic capabilities is to de-coupling of the macro base station DL/UL frequency associations using VDT as indicated in Figure 4. The D1 carrier is allowed to be associated with U1 and U2.

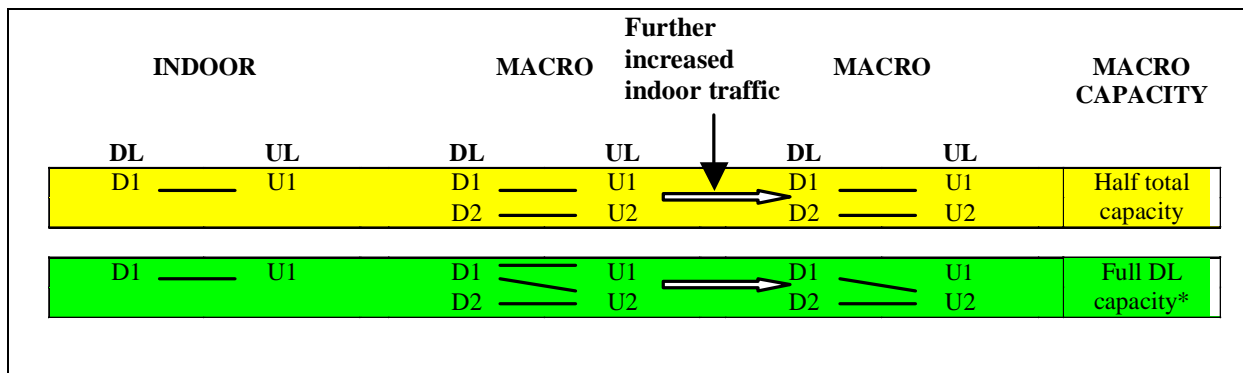

Figure 8: Indoor system for public access within the coverage area of a macro site.

Further increased aggregated indoor traffic may almost block U1. In this case carrier pairs D1-U2 and D2-U2 will carry the macro site traffic. Full macro site capacity equals full total capacity if DL traffic > 2 times the UL traffic, which may be a typical case.

This migration path requires mobiles that can perform handover between cells with different duplex distances. Such functionality is supported by the WCDMA standard.

The concept provides for a mix of handsets with and without VDT during a transition period. Handsets without VDT will in the macro site mainly use D2-U2. (VDT could additionally if wanted also be applied for the indoor system by adding D2-U1).

This solution provides full Indoor Systems and macro cell capacity. The capacity of the indoor systems can be increased as much as wanted by adding equipment (e.g. cell splitting) without damaging the planned macro site coverage.

Table 3 below is an extension of Table 2. The Third Phase with de-coupling of the macro base station DL/UL frequency associations, where macro base stations using carriers D1-U1 and D2-U2 to also support D1-U2, has been added. This phase is relevant when the indoor system traffic (aggregated traffic over the coverage area of a macro site) has further increased, so that the U1 carrier at the macro site is substantially interfered.

Table 3. Scenario with VDT. Dx-Ux are coupled Downlink/Uplink carrier pairs. Pairs in brackets are with limited or no traffic.

Phase	High traffic areas		Medium traffic areas		Low traffic areas		Comment
	Indoor Systems	Macro	Indoor Systems	Macro	Indoor Systems	Macro	
Initial	(D1-U1)	D1-U1 (D2-U2)	(D1-U1)	D1-U1	(D1-U1)	D1-U1	Coverage only. D1/U1 only. Full macro capacity/coverage.
Second	D1-U1	D1-U1 D2-U2	(D1-U1)	D1-U1	(D1-U1)	D1-U1	Traffic increases, need for Indoor Systems. D2/U2 added. Full macro capacity/coverage.
Third	D1-U1	D1-U1 D2-U2	D1-U1	D1-U1 D2-U2	D1-U1	D1-U1	Aggregated indoor traffic increases further, add D1-U2 association. Full macro capacity/coverage.

Figure 9 below gives an example of a graphic representation of the three phases of evolution for the macro site traffic on carrier pair D1-U1 shown in Table 3 and Figure 8.

N is the maximum traffic on D1-U1 in the macro site, supposing no limiting interference on U1.

An indoor cell (a building or e.g each floor of a building) is well isolated compared to outdoor macro cells.

Therefore the maximum capacity on D1-U1 is supposed to be between N and 2N at each indoor cell, depending on whether the capacity is code limited or not. In the example of Figure 9 the total aggregated indoor traffic reaches about 6N before the macro site capacity becomes UL limited. At further increase of indoor traffic the D1-U1 macro site traffic would approach zero, unless the D1 is de-coupled to allow D1-U2 pairing as shown in figure 8 and table 3.

The 6N break point is arbitrary. It could be much higher when all indoor systems are designed without trying to "force" off-loading the LOS parts of the building. NLOS areas could carry e.g. 20 N or higher aggregated traffic from several systems, without affecting the macro site. However, a single indoor system close to the macro site, where users on LOS floors are "forced" to connect to the indoor system, and the full indoor system capacity is utilized, could severely affect the macro site UL.

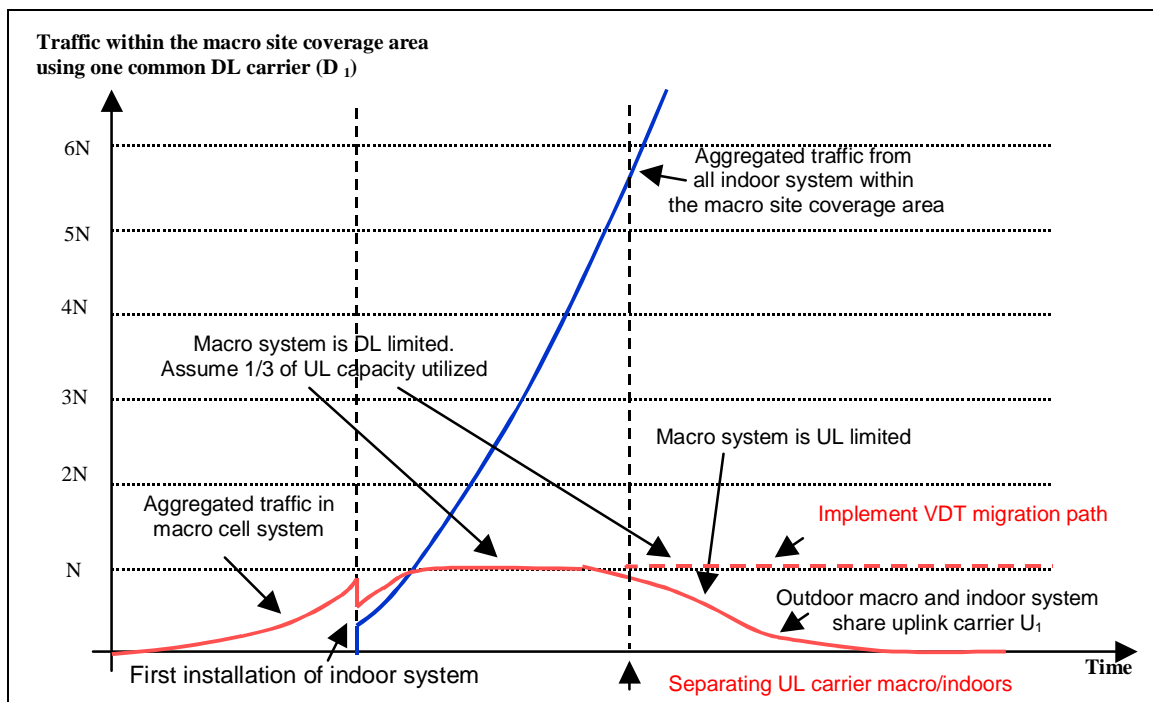

Figure 9. Example of traffic evolution for the macro site and the indoor systems within the coverage area of a macro site.

7.2.5 Summary of the use of VDT for deployment for public indoor systems

This section 7.2 describes one opportunity for using VDT in a scenario with macro and indoor cells using a common set of carrier frequencies. A prerequisite for the method to be implemented is that the Variable Duplex Technology has been developed and ready to be used in commercially available terminals.

The method suggests a de-coupling of the nominal up-link and down-link carrier associations, to provide full off-loading of macro cells and utilising the full additional capacity provided by indoor cells. VDT is implemented allowing for two downlink carriers to be coupled to one up-link. As a result, a serving macro base station can be capable of manifold multiplying the total traffic within a WCDMA macro cell area.

As a summary, the main objectives of the proposed method using VDT is to:

- give improved spectrum utilisation
- provide capacity of the indoor systems, that can be increased as much as wanted by adding equipment (e.g. cell splitting) without damaging the planned macro site coverage
- admit for a smooth transition of cellular network when traffic increases

7.2.6 Handover between cells with different duplex spacing

In the proposed scheme for use of VDT in public indoor systems, we have macro cells where two downlink carriers are coupled to one uplink carrier. Depending on the downlink carrier used, the duplex distance will be different. We will thus get handover situations where the target cell for handover will have the same downlink frequency available, but not the same uplink frequency. A normal soft handover procedure cannot be used in this case.

In the WCDMA handover procedures there exists a procedure called "Physical channel reconfiguration". This procedure indicates both the UL and DL frequencies to which the handover shall be made. Just taking the WCDMA standard as it is means that handover between cells with different duplex distances will be executed as hard handover using the "Physical channel reconfiguration" procedure as described in [9]. The situation can thus be handled with existing procedures.

It is possible (but not necessary) to define an improved handover procedure for this case and add it to the specifications. This would be a new "quasi-soft" handover, which implies that the handset is staying in soft-handover mode for the DL but changes frequency for the UL. In this way full resynchronisation is not required for the mobile.

7.3 UL/DL usage of the new band in 2500 – 2690 MHz in conjunction with the Band I for UTRA FDD

7.3.1 Introduction

Fig. 1 (adapted from ref [17]) shows a graphical representation of "Alt B" for utilizing the additional frequencies from 2500 - 2690 MHz for UTRA FDD. In here, both FDD UL and FDD DL carriers are located in the 2.5 GHz band. By using VDT, the width of the UL and DL band can be equal or one of them can be wider depending on the traffic requirements.

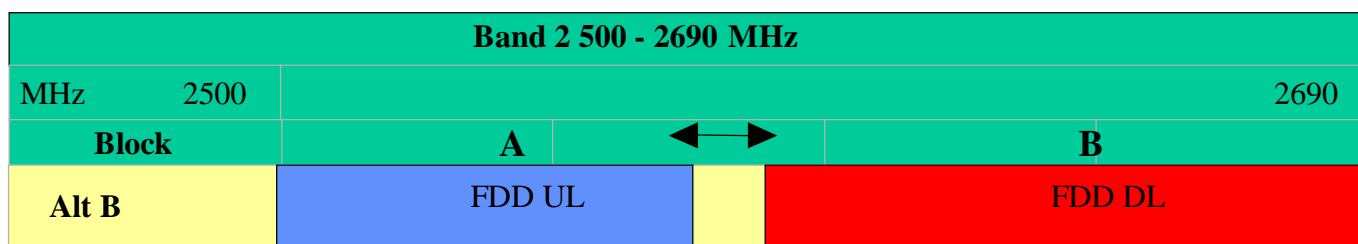

Figure 1. ITU 8F Draft Scenarios for WRC-2000 band use (adapted from [1])

“Alternative B” will support a number of important ways in utilizing the 2500 - 2690 MHz band including (but not limited to):

- Provision of a wide range of symmetric or asymmetric capacity
- Provision of additional UL/DL spectrum to support new, as well as existing operators

However, the trade-off between duplexer complexity and minimizing the duplexing gap between A ↔ B is the main issue for “Alt B”. This applies to the Node B as well as to the UE. When comparing “Alt B” with the “DL only” operation of “Alt A” (please refer to Sect 7.1) it appears that the former supports a wider range of spectrum usage patterns, but at the price of some part of the spectrum (approximately 15 %) being not usable for FDD operation due to the unavoidable duplexing gap.

7.3.2 General aspects regarding “Alternative B” within 2500 – 2690 MHz

This sub clause deals with a number of general aspects related to the “Alt B” arrangement for the 2.5 GHz band.

Sizes of the frequency blocks (A, B) within 2500 – 2690 MHz

The sizes of the blocks A and B within the new band from 2500 - 2690 MHz, as well as any possible use of guard bands between them are to be specified by regulatory bodies and are not within the scope of this TR. However, in this section we discuss areas, which need to be taken into account when making these decisions.

One of the most important aspect to achieve widespread UE roaming and low cost manufacture of UE, respectively, Node B is, that the partitioning A / B of the 2.5 GHz band is fixed and uniform across all markets (e.g. same partitioning across CEPT countries as well as all other countries utilizing the 2.5 GHz band). If this is done on a global basis this would reduce difficult design requirements for duplexing and linearity of the RX / TX chains and thus lead to a economy of scale that would be beneficial for the entire wireless industry.

Without fixed and uniform partitioning, in particular, the *roaming* capabilities of UEs would be restricted since it is not possible/feasible to design receivers with variable transition point of A and B. In addition the network searching may become complex due to different frequency planning of the UL and DL transition point.

Propagation Aspects, Impact of increased Propagation Loss

Please refer to Sect 7.1.2.1., Sect. 7.1.2.2, and Appendix A regarding the coverage/capacity impact of the increased propagation loss (PL) within the 2.5 GHz band on UTRA UL, respectively, DL operation. Based on this analysis, the UL operation in portion “A” of the 2.5 GHz band will suffer from an approximately 3 dB increased PL with a corresponding reduction of coverage, whereas the impact on the DL coverage/capacity in portion “B” is negligible.

Due to the expected stringent requirements for the duplexer, it is expected that the NF of the UE will increase approximately by 3 dB compared to Band I operation. But as noted above, the system is not DL coverage (noise) limited, so this would not be the limiting factor for operation.

In context with the 3 dB increased PL on the UE UL, it will then be important to keep the insertion loss (IL) of the Node B RX duplexer filter low in order to prevent an increase in the NF and further desensitisation of the receiver. This then points into the direction of providing a sufficiently large duplexing gap at the band transition point A ↔ B, in order to facilitate low-loss RX filter design at reasonable cost.

For the UE this implies approx. 3 dB higher transmitter output power requirements in order to compensate the propagation loss e.g. to meet same coverage as Band I with power class 4 (21 dBm) terminal, one needs to design for power class 3 (24 dBm) terminal. Additionally more losses are expected for TX, due to the narrow UL/DL separation, which will further increase the current consumption, resulting in significantly higher currents compared to Band I UL operation. This indicates that some lower power classes should be considered as well; otherwise it is not possible to design similarly performing terminals in terms of operation time and size as for Band I.

7.3.3 Interference mechanisms relevant for “Alternative B” within 2500 – 2690 MHz

The frequency arrangement of UL and DL in “Alt B” is similar to the one in the existing bands II and III, thus leading to identical interference mechanisms, for both UE and Node B. Characteristic for this band allocation is that UL and DL are close to each other and duplex gap is narrower than UL and DL bands.

7.3.4 RF Performance requirements for supporting “Alternative B” within 2500 – 2690 MHz

This sub clause discusses those RF performance requirements for the 2500 – 2690 MHz band that have a direct impact on the required duplexing gap from practical implementation point of view.

Requirements relevant for Node B

Spurious emission requirements to support FDD-FDD co-location

Based on the philosophy in [3], Sect 6.6.3.2 “Protection of the BS receiver”, a suitable starting point for a requirement for spurious emission levels at the transmit antenna port for a Node B to be co-located with another FDD system’s Node B’s is -80 dBm/3.84 MHz. With a 30 dB MCL, this leads to a maximum interference level of -110 dBm/3.84 MHz at the RX antenna port of a co-located other FDD system’s Node B, resulting in only negligible desensitisation.

The same requirement is also appropriate for the 2500 - 2690 MHz band.

Blocking requirements

Based on the philosophy in [3], Sect 7.5.2 “Co-location with GSM900, DCS1800, PCS1900 and/or UTRA”, a suitable starting point for a requirement for the interferer (blocker) levels due to a co-located “FDD external” system’s Node B at the antenna port of the “FDD internal” system’s Node B is $+16$ dBm/3.84 MHz in conjunction with a desensitisation of 6 dB.

The same requirement is also appropriate for the 2500 - 2690 MHz band.

Node B Duplexed Operation

This is the most limiting case for Node B implementation: here the spurious emissions from the own TX need to be attenuated to levels of < -110 dBm/3.84 MHz across the own RX band which requires larger TX filter attenuation as in above case, as no antenna-antenna CL of 30 dB is available.

Likewise, the RX filters must now suppress the leakage of the own TX to such low levels, as e.g. not to cause desensitisation by IMD with in-band blockers @ -40 dBm. Again, this leads to more stringent RX filter requirement as above blocking case.

Node B Implementation

Depending on the actual partition of the 2500 - 2690 MHz band into RX/TX blocks A, B, the filter selectivity requirements may be higher for the TX and/or RX filter, compared to the Band II situation. Also the higher operating frequency may increase the IL, unless e.g. resonators with higher Q-value are used. In order to achieve the required attenuation, a trade-off between cost and carrier separation has to be made. However, with presently available RF filtering technology and assuming a FDD duplexing gap of 20 MHz, it is expected that Node B duplexed operation is feasible at a cost and complexity comparable to that of a Band II Node B also for the 2500 - 2690 MHz band.

Note from the following section, that the requirements for a minimum duplexing gap are anyway dominated by the UE.

Requirements relevant for UE

From UE implementation point of view protection of own receiver from own transmitter sets the requirements for the duplex filter performance and width of needed duplex gap at the block adjacency A \leftrightarrow B in order to produce sufficient attenuation to own transmission and spurious emissions in the DL band. Opposed to “alternative C” (see Sect. 7.4), this interference situation is internal to the UE and fully deterministic; hence Monte-Carlo simulations to assess the impact are not suggested here.

A benchmark of the duplexer performance can be taken from the FDD Band II requirements. Extrapolating these into the 2.5 GHz band by considering the fraction of frequency indicates, that the minimum frequency offset between interfering UL and DL carriers needs to be in the order of 35 MHz.

The following critical aspects of UE design need to be considered for creating requirements feasible for a mass-market device:

- Duplex filter design: Sufficient attenuation needs to be achieved from TX to own RX in all conditions to avoid receiver desensitisation and maintain receiver linearity.

- Sensitivity: NF will be higher compared to Band I due to higher operating frequency and stringent duplex filter requirements (expected to be in the same order as for the Band II and Band III).
- Selectivity: Higher propagation losses will suppress also the interfering signals accordingly. It is still possible to consider increasing node B TX powers to compensate propagation loss, and we can consider that existing ACS requirements are sufficient for most of the cases.
- RX linearity: IMD3 and blocking requirements should be derived from Band II requirements. However, there is no need to introduce requirements for protection against narrowband systems.
- Transmitter output power: TX design becomes very challenging if higher propagation loss is compensated with increased UE output power. Higher output power would increase UE TX current consumption and further tighten the requirements for duplex filter. It would be worth of considering lower output power class for this band to reduce current consumption for terminals.

However, designing “Alt B” capable UE does not require development of any new or risky implementation concepts as such.

7.3.5 Summary

- Use of UTRA FDD according to “Alt B” frequency arrangement within 2500 – 2690 MHz is viable and will support flexible band usage, including (but not limited to):
 - Provision of a wide range of symmetric or asymmetric capacity
 - Provision of additional UL/DL spectrum to support new, as well as existing operators (with no impact on existing frequency arrangements)
 - Un-coordinated operation across all cell types/layers
- From UE roaming and design point of view, it would be beneficial if the partitioning A/ B of the 2.5 GHz band could be made fixed on an as global basis as possible.
- Implementing UEs or Node B’s according to the “Alt B” frequency arrangement does not require development of any new or risky implementation concepts as such
- Propagation loss in 2.5 GHz is higher and therefore cell sizes will be smaller with current UE power classes
- From terminal duplex filter feasibility point of view, in the order of 30 MHz duplex gap between FDD UL and FDD DL bands is desirable if the stringent interference protection levels present in current specifications are to be achieved.
- UE front-end design in “Alt B” will be more complex compared to “Alt A” and this will increase the losses in RX and TX paths. The losses will have impact on the UE receiver sensitivity, transmitter design and current consumption.
- UE TX current consumption will further increase, if higher maximum power levels are required to compensate link losses.

7.4 UL/DL plus additional DL usage of the new band in 2500 – 2690 MHz in conjunction with the Band I for UTRA FDD

7.4.1 Introduction

Fig. 1 (adapted from ref [18]) shows a graphical representation of “Alt C” for utilizing the additional frequencies from 2500 - 2690 MHz for UTRA FDD. In here, UTRA FDD is proposed to be operated in a “sandwiched” manner: UTRA FDD UL carriers located in portion “A” are paired with DL carriers residing in portion “D”, enclosing thereby FDD

carriers in portions⁵ “B+C” which are assumed to be paired with FDD UL carriers located within Band I. Thus, two distinct frequency arrangements for FDD operation within the new 2.5 GHz band would exist here which we will call “*FDD internal*”, respectively “*FDD external*” throughout this Section.

Band 2 500 - 2690 MHz				
MHz	2500	2690		
Block	A	B	C	D
Alt C	FDD UL (internal)	FDD DL (external)		FDD DL (internal)

Figure 1. ITU 8F Draft Scenarios for WRC-2000 band use (adapted from [1])

The combination of the “*FDD internal*” with the “*FDD external*” frequency arrangement according to “Alternative C” will support a number of important ways in utilizing the 2500 - 2690 MHz band including (but not limited to):

- Provision of a wide range of asymmetric capacity
- Provision of additional UL/DL spectrum to support new, as well as existing operators
- Provision of a DL capacity extension for existing Band I operators
- By virtue of FDD, inherently un-coordinated operation across all cell types/layers; no specific restrictions regarding the co-location of Node B’s

However, the *mutual co-existence* of these 2 frequency arrangements at the block adjacency A ↔ B within the same geographical area, or even more stringently for Node B’s, at the same location/site, are expected to be of concern for developing suitable RF performance requirements catering for “Alt C”. This applies to the Node B as well as to the UE. The dominating interference mechanisms for “Alternative C” relevant for the Node B, respectively, UE and suitable RF performance requirements are considered in the subsequent sub clauses.

When comparing “Alt C” with the “DL only” operation of “Alt A” (please refer to Sect 7.1) it appears that the former supports a wider range of spectrum usage patterns, but at the price of specific RF requirements, which is mainly due to the close proximity (spectrally as well as geographically) of the RX and TX at the block adjacency A ↔ B.

7.4.2 General aspects regarding “Alternative C” within 2500 – 2690 MHz

This sub clause deals with a number of general aspects related to the “Alt C” arrangement for the 2.5 GHz band.

General Aspects of the “Alt C” frequency arrangement within 2500 – 2690 MHz

The combination of the “*FDD internal*” with the “*FDD external*” frequency arrangement according to “Alternative C” will support a number of specific ways in utilizing the 2500 - 2690 MHz band.

The “*FDD internal*” frequency arrangement could support:

- Generally, an asymmetric DL-UL mode of operation, i.e. multiple DL carriers residing in allocation “D” may be paired with one and the same UL carrier from allocation “A”; therefore the size of (A) may differ from size of (D). This could be accomplished by use of VDT and similar concepts for asymmetric DL-UL operation as outlined in Section 7.1 of this TR.
- A number of new operator entrants with either a symmetric or asymmetric frequency allocation
- A number of existing operators with either a symmetric or asymmetric capacity extension (with no impact on existing frequency arrangements)

⁵ The designations “B”, “C” for the block intended for “DL external” operation originates from the ITU ref [1]. The subdivision of this block into B and C is immaterial for the following analysis.

The “FDD external” frequency arrangement could provide in addition:

- A number of existing operators with an asymmetric capacity extension (with no impact on existing frequency arrangements).

Sizes of the frequency blocks (A, B+C, D) within 2500 – 2690 MHz

The sizes of the blocks A-D within the new band from 2500 - 2690 MHz, as well as any possible use of guard bands between them are to be specified by regulatory bodies and are not within the scope of this TR. However, in this section we discuss areas, which need to be taken into account when making these decisions.

One of the most important aspect to achieve widespread UE roaming and low cost manufacture of UE, respectively, Node B is, that the partitioning A / B+C / D of the 2.5 GHz band is fixed and uniform across all markets (e.g. same partitioning across CEPT countries as well as all other countries utilizing the 2.5 GHz band). If this is done on a global basis this would reduce difficult design requirements for duplexing and linearity of the RX / TX chains and thus lead to a economy of scale that would be beneficial for the entire wireless industry.

Without fixed and uniform partitioning, in particular, the *roaming* capabilities of UEs would be restricted since it is not possible/feasible to design receivers with variable transition point of A and B. In addition the network searching may become complex due to different frequency planning of the UL and DL transition point.

For the following technical analysis we make the assumptions that the duplexing gap size(B+C) of the “FDD internal” system is sufficiently large [e.g. > 30 MHz] so that the RF requirements (and the required underlying RF technology such as duplexers, receiver/transmitter linearity, etc) for the “FDD internal” operation will be mainly driven by the requirements for co-existence/location with the “FDD external” mode, rather than “internal” frequency-duplex operation.

Propagation Aspects, Impact of increased Propagation Loss

Please refer to Sect 7.1.2.1., Sect. 7.1.2.2, and Appendix A regarding the coverage/capacity impact of the increased propagation loss (PL) within the 2.5 GHz band on UTRA UL, respectively, DL operation. Based on this analysis, the UL operation of the “FDD internal” system in portion “A” of the 2.5 GHz band will suffer from an approximately 3 dB increased PL with a corresponding reduction of coverage, whereas the impact on the DL coverage/capacity of the “FDD external” as well as “FDD internal” system is negligible.

Due to stringent requirements for the duplexer, it is expected that the NF of the UE’s will increase approximately by 3 dB compared to Band I operation. But as noted above, the system is not DL coverage (noise) limited, so this would not be the limiting factor for operation.

In context with the 3 dB increased PL on the UL for "FDD internal", it will then be important to keep the insertion loss (IL) of the Node B RX duplexer filter low in order to prevent an increase in the NF and further desensitisation of the receiver. This then points into the direction of avoiding excessive Node B receiver blocking/IMD3 requirements at the band transition point A ↔ B.

For the UE this implies approx. 3 dB higher transmitter output power requirements in order to compensate the propagation loss e.g. to meet same coverage as Band I with power class 4 (21 dBm) terminal, one needs to design for power class 3 (24 dBm) terminal. Additionally more losses are expected for TX, due to the narrow UL/DL separation. This will increase the current consumption, resulting in significantly higher currents compared to Band I UL operation. This indicates that some lower power classes should be considered as well; otherwise it is not possible to design similarly performing terminals in terms of operation time and size as for Band I.

System aspects and trade-offs

As already mentioned in 0, co-existence/location of the “FDD external” with the “FDD internal” system at the band transition point A ↔ B will be a challenge from Node B / UE duplex filtering point of view. When crafting the RF performance requirements for supporting co-existence/location of the “FDD external” with the “FDD internal” system, considerations regarding the following items need to be made by RAN WG4:

1. Handling of band transition point A ↔ B
2. Handling of band transition in point C ↔ D between “external” and “internal” DL.
3. Assumptions regarding the minimum coupling loss (MCL) between the systems in case of co-existence
4. RF performance of Node B and UE (ACLR, ACS, IMD3, blocking, etc)

5. Possibly lower Node B TX output powers; operation of one or both systems in micro/pico cell layers only, etc.

7.4.3 Interference mechanisms relevant for “Alternative C” within 2500 – 2690 MHz

This sub clause lists and identifies the significant interference mechanisms, which exist for “Alternative C”. It is anticipated that most of these will need to be reflected by appropriate UTRA FDD RF performance requirements for the 2500 – 2690 MHz band as well as by evolving existing UTRA FDD Band I/III and GSM specifications. Appropriate RF performance requirements dealing with these interference mechanisms will be presented in the subsequent sub clause, as far as they are new and specific for the 2500 – 2690 MHz band operation and not just a repetition of analogous Band I/II/III requirements.

Interference mechanisms impacting Node B

1) Interference from Node B of the “FDD external” system → Node B of the “FDD internal” system at the block adjacency A ↔ B, in particular under co-location conditions, leading to desensitisation of the victim Node B

- A. ACLR and spurious emissions from the TX of a Node B of the “FDD external” system falling into the RX band (portion “A”) of a Node B of the “FDD internal” system
- B. ACS interference appearing within the RX path of a Node B of the “FDD internal” system due to the TX of a Node B of the “FDD external” system
- C. Blocking of the RX path of a Node B of the “FDD internal” system due to the TX of a Node B of the “FDD external” system
- D. 3rd-order non-linearity interference appearing within the RX path of a Node B of the “FDD internal” system due to the TX of a Node B of the “FDD external” system

There are several mechanisms, some of them actually not possible in either Band I or Band II, by which IMD3 interference may appear:

- 1. IMD3 due to mixing of two received Node B carriers operating in the adjacent portion “B+C”
- 2. IMD3 due to mixing of an in-band blocker (i.e. located in block “A”) and a received Node B carrier operating in the adjacent portion “B+C”
- 3. IMD3 due to mixing of leakage from the “own” TX in block “D” and a received Node B carrier operating in the adjacent portion “B+C”

2) Interference from “Legacy” GSM900/1800 BTS → Node B of the “FDD internal” system, in particular under co-location conditions, leading to desensitisation of the victim Node B

- A. Spurious emissions from a GSM BTS system falling into the RX band (block “A”) of a Node B of the “FDD internal” system

3) Interference from “Legacy” UTRA FDD Node B operating in Band I or Band III → Node B of the “FDD internal” system, in particular under co-location conditions, leading to desensitisation of the victim Node B

- A. Spurious emissions from a UTRA FDD Node B operating in Band I falling into the RX band (block “A”) of a Node B of the “FDD internal” system
- B. Spurious emissions from a UTRA FDD Node B operating in Band III falling into the RX band (block “A”) of a Node B of the “FDD internal” system

Interference mechanisms 1), A – D) are assumed to be the dominating ones for the Node B and appropriate RF requirements need to be established.

Interference mechanisms impacting UE

4) Interference from the UE of the “FDD internal” system → UE of the “FDD external” system at the block adjacency A ↔ B, leading to desensitisation of the victim UE around the interfering UE

- A. Spurious emissions of an UE operating in close proximity on “FDD internal” band, degrading the performance of the victim UE operating on “FDD external” downlink band
- 5) Interference due to a UTRA FDD Node B operating on the “FDD external” band → RX path of UE of either the “FDD internal” or “FDD external” system**
- A. TX leakage from the uplink of the victim UE operating on the “FDD internal” band and a strong downlink signal of an interfering Node B operating on the “FDD external” band can generate an IMD product that falls into the RX path of the victim UE
- B. Uplink interference from an UE operating in close proximity on the “FDD internal” band and a strong downlink signal of an interfering Node B operating on “FDD external” band can generate an IMD product that falls into the RX path of a victim UE operating on the “FDD external” or “FDD internal” band.

From UE implementation point of view points 4) and 5) set the requirements for the duplex filter performance to reduce spurious into the DL band of the “FDD external” system, as well as to produce sufficient attenuation to own transmission. In case 5) interference mechanisms set to the UE receiver are already comparable to the requirements in the current specifications. Hence these are not discussed further in this document.

6) Interference due to Node B of the “FDD external” system → UE of the “FDD internal” system at the block adjacency C ↔ D.

- A. ACLR and spurious emissions from Node B of the “FDD external” system, falling into the RX band (block “D”) of a victim UE of the “FDD internal” system.

This mechanism is not considered as dominant, since the UE selectivity is the limiting factor.

- B. 3rd order non-linearity interference appearing within the RX path of a victim UE of the “FDD internal” system due to TX of Node B(s) of the “FDD external” or “FDD internal” system.

The latter mechanism one is normal blocking and IMD3 case as present in all band variants.

Points 6) A, B are dealt with in the current specifications and as such do not require further considerations in this context. Naturally, in terms of allocated frequency blocks, future requirements need to be aligned to reflect the new band and its concrete partition.

7.4.4 RF Performance requirements for supporting “Alternative C” within 2500 – 2690 MHz

This sub clause discusses possible RF performance requirements dealing with the interference mechanisms listed in sub clause 0 , as they are specific for the 2500 – 2690 MHz band operation and not already covered by corresponding requirements of the UTRA FDD Band I/II/III specifications.

Requirements relevant for Node B

The following general assumptions are used for the considerations of this Section:

1. Only requirements applicable for Wide Area (WA) Node B are considered. Considerations for other FDD Node B classes (Medium range, Local area) are FFS.

As RF requirements for WA Node B’s are typically the most stringent ones, this assumption then means, that we do not restrict FDD operation according to “Alt C” to e.g. micro / pico (or hot spot) cells only. Having the capability to build macro (Wide area) coverage in an economic fashion will be essential for any prospective new operator wishing to utilize the “FDD internal” system.

2. For brevity, requirements are discussed only for the case of *co-location* (as opposed to mere “co-existence in same geographical area”) of Node B’s of the “FDD internal”, respectively, “FDD external” system.

Again, the specific RF requirements for Node B co-location are typically the most stringent ones, so this means that sites could be shared among operators of the “FDD internal”, respectively, “FDD external” system in order to reduce cost of network deployment within 2500 – 2690 MHz. Note also that an operator of the “*FDD external*” system must, by definition, co-locate it with the corresponding Band I equipment. Having the possibility of co-location with a “FDD internal” installation is important here, should the latter one be already present at the targeted Band I site providing the corresponding UL part.

3. Minimum coupling loss (MCL) between the systems is 30 dB (co-location case, see [3])
4. Node B TX power is assumed to be 43 dBm
5. Additional RF filtering by means of external filters as suggested e.g. in [5], Sect. 8.4 (“Site Engineering solutions”) is not considered here

These assumptions lead to the most stringent RF requirements for Node B equipment (i.e. worst case), however, this assumes then that no operational constraints for UTRA FDD deployment within 2500 – 2690 MHz according to “Alternative C” are assumed, nor that any co-ordination among operators would be required. As already mentioned in Sect. 0, there exist various trade-offs between e.g. ACL, supported cell sizes, Node B TX powers, guard bands and RF performance requirements.

Regarding Node B equipment feasibility in mitigating interference due to 0 1), A – D, the following areas of RF design will be most impacted:

- Duplexer TX filter response
- Duplexer RX filter response
- Linearity of the TX chain (in particular the linearity of the PA device)
- Linearity of the RX chain (e.g. IIP3, ICP, etc)

From the perspective of achieving a cost of prospective Node B’s targeted for 2500 - 2690 MHz comparable to that of equipment for Band I/II, it is important that the re-use of existing RF modules and designs related to the UMTS2100/1900 standards is maximised and that the duplex filtering requirements can be met with comparable assumptions about size / complexity / performance and technology. However, building the support for “Alt C” does not require development of any new implementation concepts as such for the Node B.

ACLR, spurious emission requirements for Node B of “FDD external” system (related to 0 1) A)

Based on the philosophy in [3], Sect 6.6.3.2 “Protection of the BS receiver”, a suitable starting point for a requirement for maximum adjacent channel interference and spurious emissions levels for a “FDD external” system’s Node B at the transmit antenna port is –80 dBm/3.84 MHz. With a 30 dB MCL, this leads to a maximum interference level of –110 dBm/3.84 MHz at the RX antenna port of a co-located “FDD internal” system’s Node B, resulting in only negligible desensitisation.

In order to obtain some indication⁶ for the required additional TX filtering for the Node B of the “FDD external” system, Table 1 assumes for the TX leakage levels (i.e. PA linearity) the corresponding ACLR_{1/2} and “close-in” spurious levels according to [3]:

Table 1. Estimate of required additional TX filtering for Node B of the “FDD external” system

Carrier offset	5	10	>=15	MHz
Tx power "ext" BS	43.00	43.00		dBm/3.84 MHz
ACLR "ext" BS	45.00	50.00		dB
Tx interference level @ BS "ext" antenna	-2.00	-7.00	-9.16	dBm/3.84 MHz
FDD "ext" <-> FDD "int" antenna CL	30.00	30.00	30.00	dB
max interference level @ BS "int" antenna	-110.00	-110.00	-110.00	dBm/3.84 MHz
Req. additional Tx filtering	78.00	73.00	70.84	dB

In order to achieve the required attenuation, a trade-off between cost and carrier separation has to be taken. E. g. with 20 MHz carrier separation an attenuation of 70 dB can be achieved at a cost and complexity comparable to that of a Band I/II Node B with presently available RF filtering technology.

ACS, Blocking, IMD3 requirements for Node B of the “FDD internal” system (related to 0 1) B,C,D)

⁶ Partitioning of PA linearity vs. TX filtering will be ultimately Node B implementation dependent, i.e. this is not expected to be a Node B requirement

Based on the philosophy in [3], Sect 7.5.2 “Co-location with GSM900, DCS1800, PCS1900 and/or UTRA”, a suitable starting point for a requirement for the interferer (blocker) levels due to a co-located “FDD external” system’s Node B at the antenna port of the “FDD internal” system’s Node B is +16 dBm/3.84 MHz in conjunction with a desensitisation of 6 dB. No additional IMD3 requirement for multiple, co-located Node B interferers are formulated in the Band I/II/III specifications⁷; these are understood to be covered by these blocking performance requirement; the same approach could be taken for 2500 - 2690 MHz band.

The highest levels for Node B in-band blockers are specified in [3], Table 7.4 as –40 dBm, so the duplexer RX filter has to provide a significant amount of attenuation (depending on Node B implementation). For obtaining the desired amount of RX filter attenuation, a trade off between carrier spacing and cost will have to be made. With presently available RF filtering technology, sufficient attenuation to meet the above +16 dBm/3.84 MHz blocker requirement can be achieved with 20 MHz carrier separation at a cost and complexity comparable to that of a Band I/II Node B. Meeting such a blocking requirement on the adjacent channel is not feasible.

Spurious emissions requirement for GSM900/1800 BTS (related to 0 2) A)

Specification [4] currently mandates for the spurious emissions from the GSM900/1800 BTS onto 2500 - 2690 MHz band a limit of –36 dBm / 3 MHz. However, to support co-location with UTRA FDD/Band I, the limit for the spurious emissions is specified as –96 dBm / 100 kHz, i.e. a value approximately 45 dB smaller. Most likely, a corresponding requirement would need to be introduced in order to support co-location with the “FDD internal” system on the portion “A” of the 2500 - 2690 MHz band.

Spurious emissions requirements for UTRA FDD Node B operating in Bands I/III (related to 0 3) A, B)

Specification [3] currently mandates for the spurious emissions from a FDD/Band I/III Node B onto the 2500 - 2690 MHz band a limit of –30 dBm / 1 MHz. However, to protect a co-located FDD receiver, the limit for the spurious emissions needs to be specified as –96 dBm / 100 kHz, i.e. a value approximately 56 dB smaller. Most likely, a corresponding requirement would need to be introduced in order to support co-location with the “FDD internal” system on the portion “A” of the 2500 - 2690 MHz band.

Requirements relevant for UE

Spurious emission requirements for UE of “FDD internal” system (related to 0 4) A)

From [2], we find UE RX spurious response requirement from Table 7.11: the UE spurious emissions to the UMTS receive band 2110-2170 MHz are specified as –60 dBm/3.84 MHz. Adding 40 dB coupling between UE’s, we can conclude that the interference is at most –100 dBm/3.84 MHz at any victim UE. A corresponding requirement would need to be introduced also for the spurious emissions from the “FDD internal” system towards the UE receive bands of the “FDD external/internal” systems.

Meeting such a requirement will be dominated by the duplexer performance in the UE. A benchmark of the duplexer performance can be taken from the FDD Band II requirements. Extrapolating these into the 2.5 GHz band by considering the fraction of frequency indicates, that the minimum frequency offset between interfering UL and DL carriers needs to be in the order of 35 MHz.

Further UE-UE interference analysis (e.g. Monte-Carlo-type of statistical analysis) may be needed to be able to assess the actual system level impact (e.g. DL capacity / coverage) of this interference mechanism as a function of the UE spurious emission levels, in order to establish the eventual UE RF requirements. In particular, it may be relevant to study the impact from non-uniformly distributed UEs (e.g. UEs clustered in proximity like in rooms, inside buildings) on these requirements.

Additionally, the UE internal TX to RX attenuation needs to be sufficient to meet in-band blocking requirements.

The following critical aspects of UE design need to be considered for creating requirements feasible for a mass-market device:

- Duplex filter design. Sufficient attenuation needs to be achieved from TX to own RX in all conditions to maintain receiver linearity.
- NF will be higher (expected to be in the same order as for the Band II)

⁷ to cover cases 1) D

- IMD3 and blocking requirements are a mixture of Band I and Band II requirements. However, there is no need to introduce requirements for protection against narrowband systems.
- TX design may be need to be changed due to higher propagation loss, which is setting tight requirements for duplexers. It would be worth of considering lower output power class for this band to reduce current consumption for terminals.
- Higher propagation losses will suppress also the interfering signals accordingly. It is still possible to consider increasing node B TX powers to compensate propagation loss, and we can consider that existing ACS requirements are sufficient for most of the cases.

However, designing “Alt C” capable UE does not require development of any new or risky implementation concepts as such.

7.4.5 Summary

- Use of UTRA FDD according to “Alt C” frequency arrangement within 2500 – 2690 MHz is viable and will support flexible band usage, including (but not limited to):
 - Provision of a wide range of asymmetric capacity, in particular, the UL and DL bands of the “FDD internal” system can be asymmetric
 - Provision of additional UL/DL spectrum to support new, as well as existing operators (with no impact on existing frequency arrangements)
 - Provision of a DL capacity extension for existing Band I operators (with no impact on existing Band I frequency arrangements)
 - Un-coordinated operation across all cell types/layers
- In order to support the co-existence/location of the “FDD internal” with the “FDD external” system suitable RF requirements need to be introduced
- From UE roaming and design point of view, it would be beneficial if the partitioning A / B+C / D of the 2.5 GHz band could be made fixed on an as global basis as possible.
- Implementing UEs or Node B’s according to the “Alt C” frequency arrangement does not require development of any new or risky implementation concepts as such
- Propagation loss in 2.5 GHz is higher and therefore cell sizes will be smaller with current UE power classes
- From terminal duplex filter feasibility point of view, in the order of 35 MHz carrier separation between FDD UL internal and FDD DL external bands is desirable if the stringent interference protection levels present in current specifications are to be achieved. Further studies (e.g. Monte-Carlo-type of statistical analysis) regarding the actual system level impact of the UE-UE interference are needed in order to determine the appropriate RF requirements and carrier separation.
- UE front-end design in Alt C will be more complex compared to Alt A and this will increase the losses in RX and TX paths. The losses will have impact on the receiver sensitivity and output power which can further decrease the cell sizes
- UE TX current consumption will further increase at maximum power, if higher maximum power levels are required to compensate link losses.

8 Feasibility of UTRA TDD in the band 2500-2690 MHz

8.1 Introduction

As already indicated in clause 5 of this TR, ITU-R has investigated frequency arrangements for the terrestrial component of IMT-2000 in bands identified by WARC-92 and WRC-2000. As part of these investigations, ITU-R has considered the use of the band 2500-2690 MHz. Three basic frequency arrangements and combinations of them are

recommended in order to meet the demand for additional traffic; see [17]. One of these basic arrangements is the operation of TDD using exclusively the complete band 2500-2690 MHz. In line with this recommendation, clause 8 of this TR investigates the feasibility of UTRA TDD in this band.

Any prospective UTRA TDD deployment could comprise macro-, micro-, or pico-cells, or any combination of these cell types. There may be multiple operators of different types: established operators already providing UMTS services within the UMTS core bands, or new operators without spectrum in the core bands. These operators then would need to share the 2500-2690 MHz band for deploying UTRA TDD. As an illustrative example, in Fig. 8.1 frequency blocks A, B, C and D could be considered as frequency allocations for multiple TDD operators (the actual number of TDD licensees is not within the scope of this report, this is merely an illustrative example). Hence, it will be important for the flexible and efficient use of the band 2500-2690 MHz that no undue interference occurs across such operator assigned frequency blocks, which could degrade prospective UTRA TDD services. This then in turn would need to be reflected by appropriate RF requirements for TDD operation within the 2500-2690 MHz band, or by invocation of operational constraints on TDD spectrum usage within the 2500-2690 MHz band, or a suitable combination of these two means.

Band 2500 – 2690 MHz				
2500 MHz	2690 MHz			
Block /sub-band	A	B	C	D
	TDD			

Figure 8.1: Draft scenario for the use of UTRA TDD within the band 2500 – 2690 MHz (as developed by ITU-R in [17], subclause 6.1.4.3, Scenario 6)

In accordance with the general considerations stated in subclause 4.1.1 of this TR, only intra-TDD related interference mechanisms and suitable RF requirements will be considered. Considerations regarding the co-existence of UTRA TDD with other RAT (such as UTRA FDD) within the band 2500 – 2690 MHz are outside the scope of this TR.

8.2 New Aspects regarding TDD operation in the band 2500-2690 MHz compared to the UTRA TDD core band

As already pointed out before, clause 8 of the present study is written under the assumption that the complete band 2500-2690 MHz is used exclusively for UTRA TDD. This “TDD only” frequency arrangement equally exists in the UTRA TDD core band which has previously been subject to diverse coexistence and compatibility studies. These studies are captured in [23] and have resulted in requirements for coexistence of UTRA TDD systems as given in the relevant 3GPP specifications.

In spite of the obvious similarities with respect to the frequency arrangement in the UTRA TDD core band, the use of the band 2500-2690 MHz is associated with three new aspects which may require additional considerations:

Aspect 1:

The total bandwidth of the additional band is 190 MHz. This is significantly higher than the bandwidth of 15 to 20 MHz of the UTRA TDD core band(s). As a consequence, the coexistence analysis has to take into account a higher number of frequency channels used by potential TDD aggressor and victim carriers, in particular for mechanisms related to spurious emissions and blocking for both UE and Node B.

Aspect 2:

Due to the limited bandwidth of the current UTRA TDD core band, each operator will typically be in control of one 5 MHz block only. In the additional band 2500-2690 MHz, however, the spectrum assigned to each operator will typically consist of several 5 MHz frequency blocks. This gives rise to the following aspects:

- Possibility of synchronised TDD operation within one operator’s frequency block to reduce interference.
- Possibility of a frequency-reuse other than 1.

- Possibility of additional escape mechanisms in frequency domain beside escape mechanisms in the time domain.

Aspect 3:

Increased de-coupling between victim and interferer due to increase of path loss at higher carrier frequency.

Basic radio propagation effects such as path loss are dependent on the frequency of the signal under consideration, but independent from the detailed characteristics of this signal. Therefore, the discussion of propagation aspects for the 2.5 GHz band in subclause 7.1.2.1 of this TR is equally applicable for UTRA TDD when operated in this band. In particular, also UTRA TDD will experience an increased path loss compared to the operation at the UMTS core band. Depending on which of the two UMTS core bands for TDD is considered as reference for comparison, the increase of path loss calculated according to the equation given in 7.1.2.1 is in the range from 3.1 dB (for reference frequency equal to 2025 MHz) to 4 dB (for reference frequency equal to 1900 MHz). Taking into account additional cable losses, the increase of path loss may reach values in the order of 4.5 dB.

In UTRA TDD, this increase of path loss will affect both DL and UL in the same way, as DL and UL transmissions takes place on the same carrier frequency; thus retaining the symmetry of the link budget. Therefore, assuming that Node B and UE are capable of providing the same output power as in the UTRA TDD core band, the use of the 2.5 GHz band will mainly result in smaller cell sizes, but no changes in available traffic capacities.

The impact of the increased path loss on interference/blocker/spurious levels, etc. will be discussed in subclause 8.4.4.

8.3 Enabling technologies

The duplex arrangement of UTRA TDD is independent of the spectrum arrangement, as only one frequency channel is needed for uplink and downlink transmission. Therefore, UTRA TDD may be deployed in the band 2500-2690 MHz (as in every other new band) without the need for developing, introducing and applying new technology concepts. The only new technology required is related to the RF front-end in the transmitter and the receiver of both the UE and the Node B which has to be capable of operating in the new band 2500-2690 MHz. As this band is not significantly higher than the UMTS core band and as it is expected that the RF requirements will be similar to the requirements for the core band, it may be safely assumed that UE and Node B vendors will face no major difficulties in providing the required components.

8.4 Requirements for updating 3GPP specifications

In case the new frequency band 2500-2690 MHz will be designated to UTRA TDD, some update of the current 3GPP specifications will be necessary. The following subclauses consider all four RAN Working Groups and list those specifications where the need for an update is identified.

8.4.1 Physical layer of the radio interface (RAN WG1)

The 3GPP specifications developed under the responsibility of RAN WG1 deal with the physical layer of the radio interface between UE and UTRAN and includes the specification of physical channel structures, the mapping of transport channels to physical channels, spreading, modulation, physical layer multiplexing, channel coding and error detection. All these specifications describe physical layer procedures that are independent from the actual carrier frequency; therefore, they will be equally applicable in case of operation of UTRA TDD in the band 2500-2690 MHz. As a consequence, no requirements for updating of these specifications are identified.

8.4.2 Radio interface architecture and protocols (RAN WG2)

8.4.2.1 UE Radio Access capabilities

It has already been explained in the context of UTRA FDD in subclause 6.1.1.1.3, that UTRAN needs to be aware of the frequency bands that a given UE is able to support. Therefore, information on supported frequency bands is

included in the UE radio access capabilities which are sent to UTRAN during the initial RRC signalling. Obviously, the same is also true for UTRA TDD.

The UE radio access capabilities for both UTRA FDD and UTRA TDD are specified in [21]. According to all current versions of [21], i.e. R99, Rel-4 and Rel-5, the TDD UE is able to indicate the support of the following frequency bands as defined in subclause 5.2 of [19]:

- a) 1900-1920 MHz and 2010-2025 MHz
- b) 1850-1910 MHz and 1930-1990 MHz
- c) 1910-1930 MHz

The signalling possibilities include the indication of one of the alternatives a), b) or c) given above or of any combination of these alternatives. If the new band 2500-2690 MHz would be designated to UTRA TDD in a new release, it would be adequate to amend [21] by introducing a further signalling possibility indicating the UE support for this band.

In addition, as already mentioned in subclause 6.1.1.1.3, [22] may be used to specify requirements for UEs supporting a frequency band that is independent of a specific release. Therefore, [22] may be amended in future to enable UEs of release R99, Rel-4 or Rel-5 to also indicate support of any new band, in particular the band 2500-2690 MHz.

8.4.3 Overall UTRAN architecture and protocols of the lu interfaces (RAN WG3)

The 3GPP specifications developed under the responsibility of RAN WG3 deal with the overall UTRA architecture and the protocols of the Iub, Iur and Iub interfaces. These specifications are independent from the actual carrier frequency; therefore, they will be equally applicable in case of operation of UTRA TDD in the band 2500-2690 MHz. As a consequence, no requirements for updating of these specifications are identified.

8.4.4 Frequency bands and RF parameters (RAN WG4)

8.4.4.1 Frequency bands

Currently, subclauses 5.2 of both [19] and [20] define operation of UTRA TDD within three alternative frequency arrangements; see also subclause 8.6.2.1 above. Furthermore, these specifications state that "Deployment in existing or other frequency bands is not precluded."

In case additional frequency bands for UTRA TDD will be introduced into the 3GPP specifications, the corresponding sections in [19] and [20] have to be amended accordingly.

8.4.4.2 RF parameter

Generally, the RF parameters of Node B and UE are specified in such a way that the system built according to these specifications will be enabled to exhibit the intended system characteristics (e.g. cell size, data rate to be transported). Two further issues have to be taken into account when developing the specifications:

- a) Technology issues, related primarily to the technical feasibility of achieving the required RF parameter values in an economical way.
- b) Compatibility issues, related primarily to the coexistence with other systems.

The transition of the operating frequency from the UTRA TDD core band to the band 2500-2690 MHz may have an impact on both issues a) and b) mentioned above:

a) Technology issues: The frequency transition is associated with an increase in absolute carrier frequency and the resulting decrease in relative channel bandwidth. This may make it more difficult to achieve the same values for some basic RF parameters such as Rx sensitivity, Tx power and ACLR as currently specified for the UTRA TDD core band. In case of the UE, additional degradations may occur if the UE should be made capable of operation in more than one of the spectrum arrangements. In any case, however, it is expected that the impact of this transition on the feasibility and complexity of URA TDD equipment (Node B and UE) is minor.

b) Compatibility issues: Compatibility refers to the coexistence with other systems which may use either the same band 2500-2690 MHz or a separate band. Compatibility with other systems operating in the same band will be further discussed in the following subclauses 8.4.4.3 and 8.4.4.4. Compatibility with other systems operating in separate bands essentially refers to the interference from BS of “legacy systems” experienced by victim UTRA TDD Node B, in particular under co-location conditions, leading to desensitisation of the UTRA TDD Node B. “Legacy systems” are systems already operational prior to potential introduction of UTRA TDD within the 2500 – 2690 MHz band, and which need to be taken into account. Examples are:

- o GSM900/1800
- o UTRA/FDD in Band I or III
- o UTRA/TDD in Band I or II

Interference to/from “legacy systems” will not be considered further in this TR, since it is assumed that the related requirements will not restrict TDD deployment within the 2500 – 2690 MHz band in any significant manner. However, these mechanisms do need to be reflected in all the involved system’s RF requirements.

8.4.4.3 Relevant Interference mechanisms for use of UTRA TDD within the band 2500 – 2690 MHz

8.4.4.3.1 General

[23] provides a summary of previous studies in RAN WG4 regarding TDD-TDD interference and co-existence in the UTRA TDD core band. From these studies it is evident that the BS-BS and UE-UE interference mechanisms are dominant, which is primarily due to the possibility of low MCL values between interferer and victim prevalent in these mechanisms. It can well be assumed that the same mechanisms will be the dominant mechanisms also for operation of UTRA TDD equipment in the band 2500-2690 MHz. However, due to the enlarged bandwidth of up to 190 MHz (see Aspect 1 in subclause 8.2), the potential for interference increases, in particular for mechanisms related to spurious emissions and blocking. Hence, some of the relevant studies performed in [23] may need to be revisited in this respect, before corresponding conclusions regarding the impact of these interference mechanisms in the 2500 – 2690 MHz band can be drawn.

The subsequent subclauses 8.4.4.3.2 and 8.4.4.3.3 list BS–BS and UE–UE interference mechanisms, respectively. Appropriate RF requirements to deal with these interference mechanisms will be discussed in the following subclause 8.4.4.4.

8.4.4.3.2 Node B – Node B Interference mechanisms in the band 2500-2690 MHz

Interfering TDD Node B → interfered TDD Node B, in particular under co-location conditions, leading to desensitisation of the victim Node B receiver.

- E. ACLR from an interfering TDD Node B TX, falling into the RX of a victim TDD Node B.
- F. Spurious emissions from an interfering TDD Node B TX, falling into the RX of a victim TDD Node B.
- G. ACS interference appearing within the RX path of a victim TDD Node B due to the TX of an interfering TDD Node B.
- H. Blocking of the RX path of a victim TDD Node B due to the TX of an interfering TDD Node B.
- I. 3rd-order non-linearity interference appearing within the RX path of a victim TDD Node B due to the TX of one or more interfering TDD Node B(s).

8.4.4.3.3 UE – UE related Interference mechanisms in the band 2500-2690 MHz

Interfering TDD UE → interfered TDD UE, leading to desensitisation around the interfering TDD UE(s)

- A. ACLR from a TDD UE falling into the RX path of a victim TDD UE located on adjacent channels in close geographical proximity.
- B. Spurious emissions from a TDD UE falling into the RX path of a victim TDD UE in close geographical proximity.

- C. ACS interference appearing within the RX path of a victim TDD UE due to the TX of an interfering TDD UE located on adjacent channels in close geographical proximity.
- D. Blocking of the RX path of a victim TDD UE due to the TX of an interfering TDD UE in close geographical proximity.

8.4.4.4 Specific RF performance requirements to support deployment of UTRA TDD within the band 2500 – 2690 MHz

8.4.4.4.1 General

In order to address the interference mechanisms presented in the previous subclause 8.4.4.3, suitable RF requirements for operation of UTRA TDD within the band 2500 – 2690 MHz need to be established. As a starting point, one may consider to re-use the structure and possibly as well the numerical values of the current UTRA TDD core band RF requirements as specified in [19] and [20] for UE and Node B, respectively, with the obvious modifications to reflect the new operating band's frequency. Hence, these already existing requirements will be reviewed and additional requirements may then be identified as needed. The emphasis here will be on discussing the potential additional requirements specific for the band 2500 – 2690 MHz.

UTRA TDD systems in the band 2500-2690 deployed by different operators may be operated either in a synchronised mode or in an unsynchronised mode. The synchronised mode of operation will be discussed shortly below, while the unsynchronised mode of operation is more deeply evaluated in the following subclauses 8.4.4.4.2 to 8.4.4.4.4.

In case of **synchronised operation**, the interference mechanism Node B to UE and UE to Node B occur. As the transmission direction is aligned on all carriers and the unwanted emission performance and blocking performance improves with increasing carrier separation, it is not expected that aspect 1 mentioned in subclause 8.2 (increase of the total bandwidth of additional band) will impact the coexistence. Aspect 2 (increase of frequency block per operator) will ease the coexistence as interference scenarios can be escaped additionally in the frequency domain. However, escape mechanisms have not been taken into account in the coexistence simulations so far. The effect of escape in the frequency domain was only investigated for FDD in [25]. As the interference mechanism is similar for TDD, a similar gain can be expected here as well. The increase in de-coupling (aspect 3) between UE and Node B will be in the range from 2-4 dB depending on the assumed path loss model. This may as well ease the coexistence, but it is not expected that this will have a significant impact as the interferer has to increase its output power to cope with the increase in path loss.

As a consequence, there seems to be evidence that coexistence considerations performed for the UTRA TDD core band in synchronised operation are equally applicable for the additional band 2500-2690 MHz. Thus, synchronised operation is not further evaluated in this TR.

The examination of **unsynchronised operation** as performed in the subclauses below is based on the following assumptions:

- Wide Area BS (i.e. macro-cells) are considered as this implies the least restrictions regarding TDD deployment (e.g. regarding economic provision of basic TDD coverage within the 2500 – 2690 MHz for new operators).
- No specific assumptions are made regarding the partitioning of the 2500–2690 MHz band into operator license blocks.
- Frequency re-use equal to 1 should be supported to enable high spectral efficiency.
- Unsynchronised TDD operation among all operators within the 2500 – 2690 MHz band (in order to minimize the need for coordination among operators). This includes the freedom to choose the UL/DL capacity allocation independently and hence supporting a flexible TDD deployment matched to each operator's individual service offering.
- Co-existence of BS – BS as well as UE – UE within the same geographical area should be supported (in order to minimize coordination among operators).
- Co-location of BS – BS should be supported (to be able to take advantage of already existing sites and to share sites for TDD deployment within the 2500 – 2690 MHz band).

- Additional isolation by means of external RF filters as suggested e.g. in [23], Sect. 8.4 (“Site Engineering solutions”) is not considered here as these would not be covered by RF requirements as defined in the relevant 3GPP specifications.

8.4.4.4.2 Support for unsynchronised TDD in case of BS - BS co-location

In case of unsynchronised operation, the transmission directions will be partly the same and partly reversed. For the time periods with the same transmission directions, the same considerations as for the synchronised operation apply. For the periods with reverse transmission direction, the interference mechanism BS to BS and UE to UE interference occur.

Specifications in [8] and [20] for BS-BS co-location (co-siting) in current 3GPP bands were derived assuming a MCL of 30 dB; see also [23]. The same value will also be assumed for operation in other frequency bands, in particular in the band 2500-2690 MHz (although aspect 3 mentioned in subclause 8.2 might suggest a slightly higher value).

In subclause 8.4.4.3.2, the BS-BS interference mechanisms A-E have been identified. These mechanisms may be divided into two groups: mechanisms A and B which are associated with the BS TX and the related unwanted emissions specifications, and mechanisms C, D and E which are associated with the BS RX and the related specifications for ACS and blocking characteristics.

With respect to the interference mechanisms A and B and the related unwanted emissions specifications, [20] supports the BS-BS co-location in case of unsynchronised UTRA TDD in current 3GPP bands with two requirements: ACLR related leakage power limits are specified at -73 dBm/3.84 MHz for adjacent channel offsets of 5 MHz and 10 MHz, and spurious emissions limits – applicable at distances larger than 12.5 MHz – are specified at -76 dBm/3.84 MHz. Note that both requirements are defined in terms of an absolute power level and that the same requirements do apply to multi-carrier operation. That means that these requirements already take into account aspect 2 of subclause 8.2 if applied also for the frequency band 2500-2690 MHz.

According to aspect 1, the number of TDD carriers in the 2.5-2.69 GHz band will be higher than in the current bands. It may nevertheless be assumed that only one base station will be at MCL and the interference is dominated by this base station. In the same way as for protection of the adjacent FDD UL band in the current band allocation, the spurious emission requirements are tighter with respect to the ACLR requirements. That means aspect 1 is already taken into account.

As a consequence, the unwanted emissions requirements as specified in [20] for BS-BS co-location in current bands seem to be sufficient to control the interference mechanisms A and B for the new band 2500-2690 MHz also and are not considered further.

With respect to the additional BS-BS interference mechanisms C and D, [20] currently does not define specific blocking/ACS requirements for co-located TDD BS in unsynchronised operation. This is due to the fact that in TDD the same frequency is used for receive and transmit. A RF-filter, which improves the unwanted emission performance, will also improve the receiver blocking performance. Further, the victim system may synchronise itself to the interfering system or accept a higher interference level in certain timeslots as it can allocate these timeslots to UEs close to the base station. Hence, from the perspective of a general requirement for the receiver, only the requirements for synchronised operation are considered as necessary.

Finally, with respect to the BS-BS interference mechanism E, [8] and [20] currently do not set any particular requirements for protection against IMD3 due to co-located BS(s) (e.g. in the case of GSM1800). The same approach could be used also here for the 2500 – 2690 MHz band, i.e. assuming that the blocking requirements for co-location are sufficient.

From the considerations above it may be concluded that the requirements currently defined in [20] are also adequate to take due account of the identified BS-BS interference mechanisms A-E in case of BS-BS co-location in the frequency band 2500-2690 MHz. A different issue is related to the question to what extent the technical feasibility of meeting these requirements is affected by the frequency band. Further study may be required, even if the corresponding requirements are already existent for the current band. E.g. due to potentially large frequency allocation for prospective TDD operators, multi-carrier Wide Area BS may be desirable which (depending on the BS implementation chosen e.g. regarding the design of the RF front end filters (like passband bandwidth, IL, etc)) may (or may not) make these requirements harder to fulfil in the 2500 – 2690 MHz band compared to the current band. In case the operator uses its carriers in an unsynchronised way (i.e. different switching point on carriers), it is expected that individual RF front end filters would be required for carriers with different switching points. In this case, the passband bandwidth may not differ

from the bandwidth in the current spectrum and a similar filter implementation as for the current spectrum could be used.

8.4.4.4.3 Support for unsynchronised TDD BS – BS co-existence within the same geographical area

The derivation of unwanted emissions requirements for BS-BS co-existence within the same geographical area in current 3GPP TDD frequency bands is based on BS-BS decoupling values (MCL) of 67 – 74 dB. These values are derived from reference scenarios as described in [23]. If deployment in the frequency band 2500-2690 MHz is considered, aspect 3 of subclause 8.2 would lead to an increased de-coupling for the reference scenarios. Assuming the free space path loss model (line-of-sight), the increase of de-coupling would be in the order of about 2 dB.

In case of support for coexistence of unsynchronised TDD BS in the same geographic area, the considerations given above in subclause 8.4.4.2 for co-located BS can be applied accordingly. Thus, it may be concluded that the requirements specified in [20] in support of TDD BS co-existence in the same geographic area for operation in the current 3GPP frequency bands are also sufficient for operation in the band 2500-2690 MHz. Concerning the technical feasibility, the same considerations as for co-location apply.

8.4.4.4.4 Support for unsynchronised TDD UE–UE co-existence within the same geographical area

UE–UE co-existence within the same geographical area is related to the possible impact of interference mechanisms A-D as described in subclause 8.4.4.3.3. These interference mechanisms may lead to severe impairments when the interfering and the victim UE come into very close geographical proximity to each other resulting in a MCL in the order of only 40 dB.

Generally, investigation of interference between radio systems may be performed on a deterministic level or on a statistical level. Investigations on a deterministic level are based on an assumed specific mutual position of stations representing these systems, typically associated with the worst-case MCL value. Such kind of investigations might be performed relatively easy in a straightforward way. In case of mobile systems such as UTRA, it is suggested that deterministic investigations are primarily appropriate for BS-BS interference scenarios only. For UE-UE interference scenarios, however, statistical/Monte Carlo type investigations seem to be better suited to capture the system level impact. Therefore, only statistical investigations based on simulations are considered in this context.

Simulations of TDD UE to TDD UE interference were already performed for operation in the current 3GPP TDD bands; corresponding results can be found in [23]. Configurations considered were Macro-Macro, Micro-Micro, Pico-Pico and Macro-Micro scenarios. In the simulations, one victim carrier and one interfering carrier were taken into account. The user distribution was assumed as uniform. In all simulated scenarios, the capacity loss was below 4%.

The evaluation whether these results are also applicable in case of operation of UTRA TDD in the band 2500-2690 MHz needs the consideration of the new aspects 1 to 3 as defined in subclause 8.2:

Consideration of Aspect 1: As mentioned above, coexistence simulations for operation in the current 3GPP TDD bands were limited up to now to one interfering and one victim system and to uniform UE distributions only. When more than one interfering system is considered, the following aspect may be taking into account:

- It may well be expected that the composition of traffic to be transported will evolve over time from more voice-dominated scenarios to scenarios with higher data rates. Therefore, it is expected that the number of users in the new band will increase slower than the number of carriers.
- As was mentioned earlier, it may be anticipated that the characteristics of the traffic to be transported in the future band 2500-2690 MHz will generally tend towards unsymmetrical behaviour in such a way that DL traffic will dominate. This higher ratio may be of benefit in case of strong interference, because a higher number of DL time slots will be available for victim UEs employing escape mechanisms in the time domain
- The unwanted emissions performance are expected to improve with increasing carrier separation.

Consideration of Aspect 2: If operators have more than one TDD carrier, the escape can take place both in the time domain and in the frequency domain to degrade the impact from unwanted emissions. This should improve the performance of DCA.

Consideration of Aspect 3: In the same way as for the other interference scenarios, the increase in carrier frequency will result in an increase of the de-coupling between victim and interferer. On the other hand, the increased coupling

loss will lead to an increase of the transmit power of the interfering UE. It is expected that these effects will counteract and that there is no additional impact on the capacity loss from this effect.

First Monte-Carlo simulations were performed for the 1.28 Mcps TDD option over a 190 MHz frequency band with all carriers unsynchronised and uniform user distribution. Aim of these simulations was the investigation of **aspect 1** (increased number of aggressing carriers) for the effect of spurious emissions. The simulations were performed with speech users on all carriers and symmetric UL/DL ratio..

These first simulation results indicate that the impact on capacity loss may increase to some extent with respect to a single interfering carrier. However, the simulation also suggests that this capacity impact may be effectively counteracted and compensated by dynamic channel allocation in the time domain. However, in order to assess the impact of UE to UE interference and suitable RF requirements in more detail, further studies may be needed regarding the aspects of impact of larger cell sizes (e.g. 577 m) and impact from non-uniformly distributed UEs.

8.5 Summary

- TDD is a viable option for operating within the 2500 – 2690 MHz band
- UTRA TDD allows the autonomous frequency allocation for new operators, which do not have a frequency block in the core bands
- The following new aspects regarding TDD operation in the band 2500 – 2690 MHz compared to the UTRA TDD core band have been identified:
 - Higher propagation loss within 2500 – 2690 MHz compared to the UTRA TDD core band which may affect the numerical values of some of the RF requirements for UR and/or node B.
 - The large potential bandwidth of up to 190 MHz available for TDD within the band 2500 – 2690 MHz increases the potential for interference, in particular for mechanisms related to spurious emissions and blocking.
 - Possibility for prospective TDD operators within the band 2500 – 2690 MHz to deploy multiple TDD carriers. This will have a positive impact on the potential for escaping interference as well as a negative impact on the equipment (BS, UE) feasibility regarding the projected RF requirements (e.g. ACLR, spurious emissions).
- TDD RF performance requirements as currently formulated for the TDD core band operation if applied to the 2500 – 2690 MHz band may result in a number of TDD/TDD interference cases. First Monte Carlo simulations suggest that UE-UE interference can be counteracted by escape mechanisms such as DCA, however further studies with larger than 280 m cell sizes are needed to assess the impact of UE-UE interference in other deployment scenarios. For BS-BS interference scenarios, the requirements maybe derived in a similar way as for the UTRA TDD core band.
- The study on the use of UTRA TDD in the band 2500 – 2690 MHz does not reveal any general new technical aspects and does not require the development and implementation of new concepts.

9 Conclusions

Within the present study, the viable deployment of UTRA in additional and diverse spectrum arrangements was investigated taking into account both the present UTRA frequency bands and the additional frequency bands identified by WRC-2000, in particular the band 2500-2690 MHz. Both UTRA modes FDD and TDD were considered. The study focussed on the feasibility of such deployments; therefore, no attempt was made to compare different frequency arrangements to each other. Accordingly, no specific frequency arrangement is recommended here. Nevertheless, some general recommendations are provided for each UTRA mode, partly covering required further work.

Co-existence between UTRA FDD and UTRA TDD within 2500 – 2690 MHz has not been considered in this study and the corresponding compatibility studies between these modes are thus left for future studies. It is however acknowledged that the combination of FDD and TDD in new bands is a valid option, as already discussed in ITU-R WP 8F.

6.1.4.3 Scenarios for the Band 2 500 – 2690 MHz		
MHz	2500	2690
Scenario 1	FDD UL (internal) ↔	TDD ↔ FDD DL (internal)
Scenario 2	FDD UL (internal) ↔	FDD DL (external) ↔ FDD DL (internal)
Scenario 3	FDD UL (internal) ↔	TDD ↔ FDD DL (external) ↔ FDD DL (internal)
Scenario 4	FDD DL (external) ↔	TDD
Scenario 5	TDD ↔	FDD DL (external)
Scenario 6	TDD	
Scenario 7	FDD DL (external)	

Figure 9.1. Proposed scenarios for band allocation according to ITU-R [17].

For UTRA FDD, the following has been shown:

- A large number of spectrum arrangements for FDD are presented in Section 5 using either variable duplex per carrier or fixed duplex distances per spectrum arrangement. It is demonstrated in Section 6 that Variable Duplex separation is fully supported by the standard, and some modifications to support variable duplex between spectrum blocks will be needed.
- The technical feasibility of implementing multiple band pairing options using variable duplex between bands is demonstrated in Section 6. Support of multiple band pairings will facilitate roaming and will also enable operators to provide service in multiple bands. It is however recommended not to have this variable duplex spacing capability mandatory in terminals, since some extra hardware is required that may increase the cost and power consumption of the UE.
- The feasibility of using of the band 2500 – 2690 MHz as DL (scenario 7 in above Figure 9.1) in conjunction with Band I is demonstrated in Section 7.1. This arrangement is viable and there is impact on the specifications only in a few localized areas such as RRM measurements, and RRC procedures. Implementing UEs according to DL only frequency arrangements does not require development of any new or risky implementation concepts as such.
- Additional use of variable duplex for deployment in public indoor systems was further discussed in chapter 7.2. It is shown to provide increased flexibility of spectrum utilisation and could in that way give capacity gains. . Such a deployment is described for a generic FDD band pairing that applies to any band.
- Use of UTRA FDD according to “Alt B”, (scenario 1 in Figure 9.1 excluding TDD interference analysis); frequency arrangement within 2500 – 2690 MHz was demonstrated in section 7.3. This arrangement is viable and will support flexible band usage. There is a need to further study the size of the duplex gap, possible guard bands for TDD and other radio requirements for this scenario.
- Use of UTRA FDD according to “Alt C”, (scenario 2 in Figure 9.1) frequency arrangement within 2500 – 2690 MHz was demonstrated in section 7.4. This arrangement is viable and will support flexible band usage. There is a need to further study the amount of guard band and other radio requirements for this scenario.

Following recommendations are made for UTRA FDD:

- 1) The support of band combinations and pairing should be market and technology driven. The accommodation of several band pairings should not be mandatory, this is left to the discretion of the UE manufacturers in consort with the operators. The standard should however enable implementation of several band pairings to allow for efficient spectrum usage depending on the market situation.
- 2) Further studies for Rx and Tx RF performance requirements is required before specifications can be finalised for UEs accommodating several band pairings.
- 3) To develop protocols to allow a UE to declare if it can operate in more than one band and what are the bands in which it can operate.

- 4) From UE roaming and design point of view, it would be beneficial if the scenario for the 2.5GHz band could be aligned on as large global basis as possible, including the possible partitioning A/B in “Alt B” or A/B+C/D in “Alt C”.

For UTRA TDD, the following has been shown:

- The feasibility of using TDD in the band 2500 – 2690 MHz (scenario 6 in above Figure 9.1) is demonstrated in Section 8. This arrangement is viable and allows the frequency allocation for new operators, which do not have a frequency block in the core bands. There is a need to further study the radio requirements for this scenario due to the wider operating bandwidth possible in 2500 – 2690 MHz.

Following recommendations are made for UTRA TDD:

1. The support of TDD in various bands should be market and technology driven. The accommodation of combination of FDD band pairings and TDD should not be mandatory, this is left to the discretion of the UE manufacturers in consort with the operators. The standard should however enable implementation of all options to allow for efficient spectrum usage depending on the market situation.
2. Further studies of Rx and Tx RF performance requirements are required before specifications can be finalised for TDD in the new bands. In case of TDD deployment in 2500-2690 MHz, further studies regarding specific TDD/TDD UE interference cases are needed, which may include non-uniformly distributed UEs.
3. To develop protocols to allow a UE to declare if it can operate in more than one band and what are the bands in which it can operate.

Annex A: Impact of increased PL in the 2.5 GHz band on UTRA FDD UL/DL Cell Coverage

Under typical operating conditions of currently fielded UMTS networks, the UL becomes *coverage* and the DL *capacity* (or interference) limited, for a more detailed analysis please refer to e.g. references [15,16].

This fundamental dynamics can be read off from Fig. A.1 when comparing the load curves marked “Uplink path loss” respectively “Downlink path loss_all_traffic_in_2.1GHz” for a single carrier reference case operating in the Band I. The cell is UL coverage limited at 153 dB PL achieving an UL throughput of 1000 kbps corresponding to a load factor of 0.6. However, the DL capacity limit (here as example: load factor of 0.78, giving 700 kbps throughput) is reached *before* the UL reaches its load limit of 0.6. On the other hand, there is ample margin for DL *coverage* compared to the UL, here approximately 8 dB. Also we note from Fig. A.1, that the *asymmetry ratio* DL / UL throughput is only 0.7, i.e. the DL has only 70% of the UL capacity.

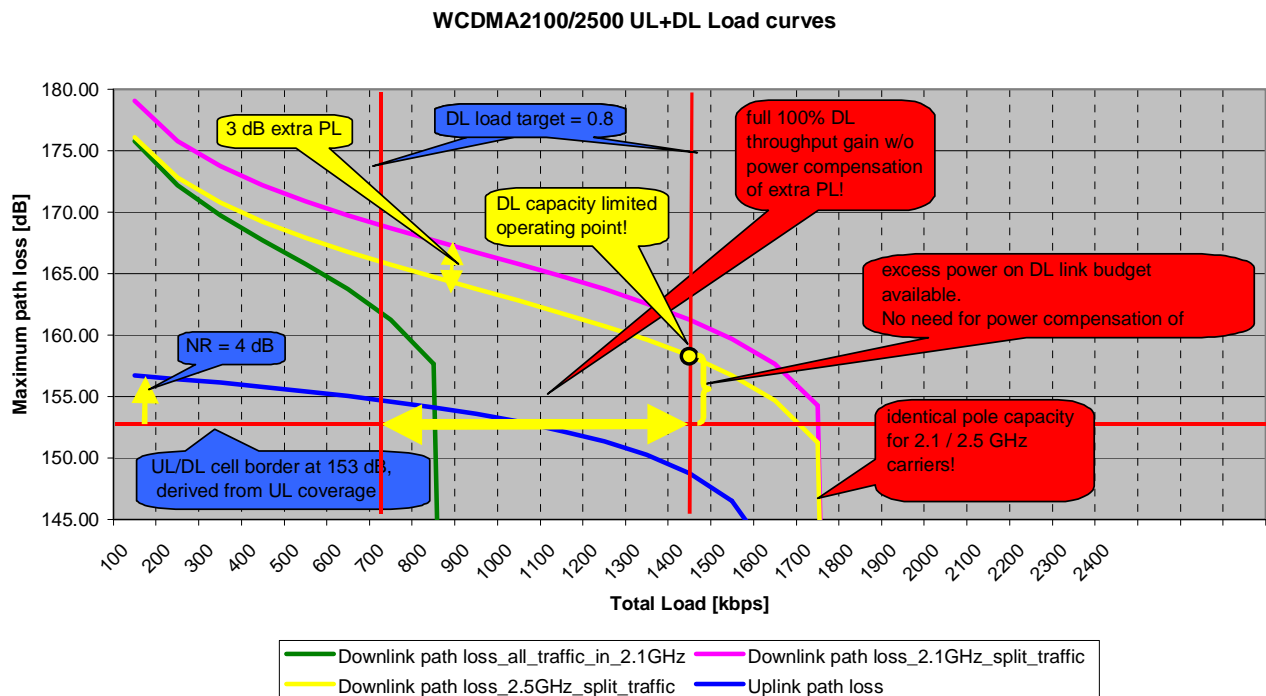

Figure A.1: UL/DL Load Curves for UTRA Operation in 2.1/2.5 GHz band

Figure A.1 also shows how the increased PL in the 2.5 GHz band of approximately 3 dB effects to the UL/DL cell coverage limitations by introducing an additional carrier in the 2.5 GHz band and splitting the DL load equally between these 2 DL carriers. The following observations can be made:

- at each throughput point, the fractional DL load value is equal for 2.1 / 2.5 GHz, in particular for the pole capacity (DL load = 1). No DL capacity is lost due to the extra PL. This is a consequence from the fact that the DL load equation (see [15], p. 159) does *not* depend on the path loss.
- The introduction of the additional DL 2.5 GHz carrier doubles the DL capacity
- The introduction of the additional DL 2.5 GHz carrier doubles the DL / UL throughput asymmetry
- There appears no need for power compensating the additional PL on the 2.5 GHz carrier for coverage reasons as there is ample margin for DL coverage available (5 dB)
- As long as the DL / UL throughput asymmetry is > 1.4 (for this example), the UL can carry the additional traffic to support the 2.5 GHz carrier with no adverse effect on the cell size

The following parameters were assumed in preparing Figure A.1:

Table A.1: Uplink parameters

UL_EbN0_dB	1.5
UL_Cable_loss_dB	2
UL_Other_cell_interference	0.65
UL_load_factor	0.6

Table A.2: Downlink parameters

MS_noise_figure_dB	9
MS_antenna_gain_dBi	0
Peak_to_average_path_loss_dB	6
EbN0_dB	5.0
DL_load_factor	0.78
Orthogonality	0.5
Other_cell_interference	0.65
Antenna_gain_dBi	18
Common_channel_OH	15%
Common_channel_OH_2.5GHz	15%
Cable_loss_dB	2
Body_loss_dB	0

Table A.3: Parameters for 2.5 GHz

additional_Cable_loss_dB	0.4
additional_Path_loss_dB	2.57
additional_Comb_loss_dB	0

Annex B: TDD UE-UE Interference Simulations

B.1 Introduction

TDD-TDD coexistence simulations so far were limited onto one victim system and one interfering system (see TS25.942 for details). In the simulations the interfering system was typically allocated onto the carrier direct adjacent to the victim system. When considering the use of TDD in the complete band 2500-2690 MHz, not only the adjacent channel UE emissions but also the UE spurious emission from unsynchronised TDD operators will contribute to the total interference at the victim UE. Aim of this simulation is the investigation of UE to UE interference with all systems unsynchronised in the complete 2500-2690 MHz band. In the simulation only the 1.28Mcps TDD option is considered.

B.2 Simulation Assumption

B.2.1 System scenario

B.2.1.1 Frequency allocation

In the band 2500-2690 MHz, a total bandwidth of 190MHz is available. Assuming for each operator a frequency block of 10 MHz, 19 operators and totally 114 carriers can be used for 1.28Mcps TDD in this band. The victim operator under investigation is assumed to be located in the centre of the band, as illustrated in Figure B.1. The numbers in the figure indicate different operators.

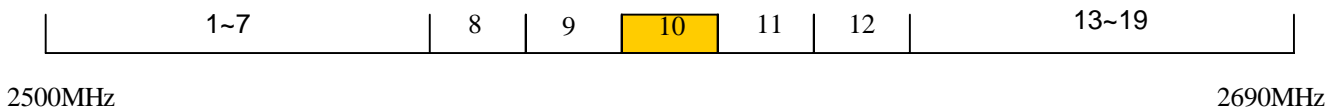

Figure B.1: Frequency allocation assumption for 2.6GHz band

B.2.1.2 Frame structure and timing between operators

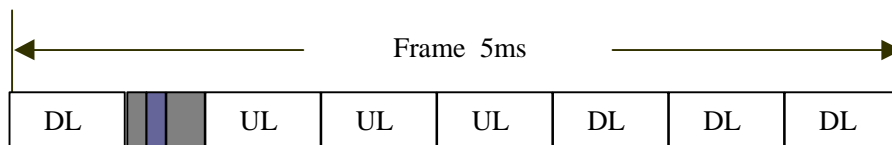

Figure B.2: 1.28Mcps TDD frame structure

Each operator is assumed to have the frame structure as shown in Figure B.2 but has random relative timing to the victim operator (operator 10 in figure B.1). None of the operator is assumed to be synchronised with operator 10. When there is any overlap among operator 10 DL timeslots and the other operators UL timeslots, the interference power from that overlapped time slot is taken into account in the victim system.

In case timeslots overlap partly, the interference is averaged over the timeslot in the victim system. This is considered to be a reasonable assumption due to interleaving and the large number of interfering carriers.

B.2.1.3 Cell structure

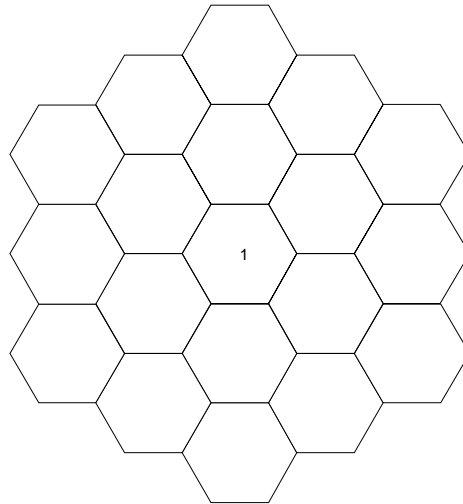

Figure B.3: system cell structure

All operators are assumed to be co-located and have the same cell radius, each operator has three rings cell structure and only the users in the centre cell are investigated, which named 1 in Figure B.3. It should be noted that co-location is considered to be the most critical deployment scenario for UE to UE interference.

B.2.1.4 UE distribution

All users in 2.6GHz band randomly choose its location (uniform distribution), its time slots and carriers.

For each user, the BS with lowest path loss on its carrier is chosen as its serving BS. The load is determined by the 5 % outage criteria for the single operator simulation. The load is considered to be equal for victim and interfering carriers.

B.2.2 Simulation parameters

This section summarises the simulation parameters for the 1.28 Mcps TDD option, which are used to describe the ‘victim system’ and the ‘interferer system’ in the coexistence simulation scenarios. The simulation assumptions partly differ from the assumption as stated in [B.6]. In particular, the cell size is reduced to 280 m in order to increase the user density. In addition the antenna gain is reduced to 8 dBi to increase the transmit output of the interfering UEs. For the victim system, the antenna gain is as well reduced to 8 dBi and the maximum BS output power is reduced to 34 dBm to reduce the power margin in the victim system. The CIR values are taken from reference [B.1]. All simulation parameters are listed in the following tables.

Table B.1: General System Parameters

No.	Parameter		1.28 Mcps TDD	
			UE	BS
P1	Chip rate	Mcps	1.28	
P2	Frame length	ms; chip	10ms; 12800	
P3	Slot length	ms; chip	675 μ s; 864	
P4	Slots per frame	1	14 (+ pilots and guard period)	
P5	Chip length	ns	781.25ns	
P6	Sfmax	1	16	
P9	No. of codes per TS	1	16	
P10	No. of codes used for an 12.2 kbps speech service	1	UL: 1x SF=8 DL: 2x SF=16	
P11	User bandwidth	MHz	1.28	
P12	Channel spacing	MHz	1.6	

Table B.2: Receiver Parameters

No.	Parameter		1.28 Mcps TDD	
			UE	BS
RX2	Noise figure	dB	9	7
RX3	Antenna gain (incl. losses)	dBi	0	8
RX4	ACS	dB	33	45
RX5	Min. CIR ⁸ for 12.2 kbps speech	dB	-3.4	-3.3

Table B.3: Transmitter Parameters

No.	Parameter		1.28 Mcps TDD	
			UE	BS
TX1	Max. TX power	dBm	21	34
TX2	Min. Tx power	dBm	-49	4
TX3	Antenna gain	dB	Same as RX3	
TX4	PC dynamic range (1 code considered)	dB	Max -(-49) = 70	30
TX5	ACLR	dB	33 (43)	40 (45)
TX6	Spurious ⁹	dBm/1.28MHz	Max(-55, UE output power-50dB)	-

Table B.4: Simulation Parameters

Parameter	1.28 Mcps TDD
Simulation Type	Snapshot
Propagation Parameters	
Frequency	2600 MHz
Antenna position over ground	MS: 1.5m BS: antenna height (15m) + average roof top level (12m) =27m
Minimum coupling loss (MCL)	BS-UE: 70, UE-UE: 40
Antenna gain	UE: 0 dBi; BS: 8dBi
Log normal fade margin	10 dB

⁸ See reference [B.1].

⁹ Here, 50dB is used in the calculation of UE spurious emission power. In 3GPP, it is specified for spurious emission, -30dBm/1MHz should be fulfilled, it approximately to -29dBm/1.28MHz, assume the UE maximum output power is 21dBm, then equivalent 3rd onwards adjacent channel leakage power ratio is 50dB.

Step size PC	Perfect PC
PC error	0 %
Margin in respect with C/I	0 dB
Outage condition	C/I target not reached
Satisfied user	C/I less than C/I target – 0.5 dB
Handover modeling	None (UE is allocated to the strongest BS)
Admission control	Not included
User distribution	uniform across the network
Interference reduction	
MUD	on
Non orthogonality factor	0
Deployment scenario	
Macrocell	Hexagonal with BTS in the middle of the cell
BTS type	Omni-directional
Cluster size	1
Cell radius	Macro: 280m
Inter-site distance (single operator)	560m
Intersite shifting	0m

B.2.3 Description of the propagation model

B.2.3.1 BS-to-UE and UE-to-BS propagation model

In accordance with the ETSI 30.03 recommendation COST 231 – Hata Model with small modifications are used in the simulation.

The path loss L depends on the distance d between the base station antenna and the mobile, the frequency f , the heights of the base station antenna H_b and the mobile H_m and the clutter type. The path loss is given by the formula in dB.

It is possible to use the model both for large and small cells where the base station antenna height is above the roof-top levels of buildings adjacent to the base station.

$$L_{pathloss} = 46.3 + \left(33.9 \log \left(\frac{f}{MHz} \right) \right) - \left(13.82 \log \left(\frac{h_{BS}}{m} \right) \right) - a \left(\frac{h_{MS}}{m} \right) + s_i \log \left(\frac{d}{km} \right) + L$$

$$s_i = 44.9 - 6.55 \log \left(\frac{h_{BS}}{m} \right)$$

where the correction factor for the UE antenna height h_{MS} are calculated according to

$$a \left(\frac{h_{MS}}{m} \right) = 3.2 \times \left(\log \left(11.75 \times \frac{h_{MS}}{m} \right) \right)^2 - 4.97$$

The impact of the clutter types is taken into consideration according to the following formulas

$$L = 0$$

The Macro model described above is applied with 10dB log-normal fading.

This path loss differs from the macro cell path loss model as used in [B.3]. The given path loss models leads to an approximately 12 dB higher path loss. With respect to UE-UE interference simulations, it is expected that this path loss model is more critical as the transmit power of the interfering UEs increases and the power margin in the victim is reduced.

B.2.3.2 UE-to-UE propagation model

The propagation model employed in NLOS condition is model for pedestrian test environment as described in [B.2]:

$$L = 40 \log_{10} d / Km + 30 \log_{10} f / MHz + 49$$

This is seen as reasonable approximation of the scenario. The propagation model employed in LOS condition is the free space loss model. For distance above $x_{\max} = 50$ m between UEs the NLOS model is used. For distance below x_{\min} , where at x_{\min} $PL_{\text{LOS}}(x_{\min}) = PL_{\text{NLOS}}(x_{\min})$, the LOS path loss model is used. Between x_{\min} and x_{\max} , the pathloss is randomly chosen, where the probability for LOS decreases linearly with increasing distance. The standard deviation of the log-normal fading is $\sigma = 12$ dB for the NLOS model and 0 dB for the LOS model.

This is in principle the same pathloss model as used in [B.3]. For brevity, a simplified NLOS model is used.

B.2.4 DCA

DCA algorithm in time domain is modelled in the following way. Assume each victim UE is located at TS4, TS5, TS6, separately, then choose the best time slot, which has the smallest total interference power as its activated time slots. That means for each victim UE the best out of the three available time slots is chosen.

Besides the DCA algorithm in time domain, DCA in frequency domain is available in addition, because each operator can use a total of 6 carriers (corresponding to a 10 MHz block). For simplicity in this simulation only the DCA algorithm in time domain is considered.

B.3 Simulation Procedure

For each snapshot, the UE position, carrier and time slot information are randomly generated according to B.2.1. Then according to the operators timing relation in this snapshot, all the UEs of aggressing operators involved in the interference scenarios are collected as interferer and all UEs belong to operator 10 are regarded as victim. BS to BS interference is not considered in the simulations.

The UE in the victim system will encounter three parts of interference in a certain period that is,

$$I_{\text{tot}} = I_{\text{UE,other}} + I_{\text{BS,own}} + \text{thermal_noise}$$

where,

$I_{\text{UE,other}}$ is the total interference power from interfere UEs of other operators

$I_{\text{BS,own}}$ is the interference power from BSs in adjacent cells

Thermal_noise is the noise power of UE receiver

In order to get the interference power from each interfered UE, all UEs belong to aggressing operators are UL power control¹⁰ until a stable state is reached. Then the output power minus the path loss to each victim UE of operator 10 is calculated and all the receiving interference power are accumulated as the interference power from aggressing UEs, which is the first part described above.

Also the interference power from BSs in adjacent channel of operator 10 and thermal noise power are calculated, all these power are added to obtain I_{tot} .

Then the DL power control is simulated for operator 10, after the power control loop reached a stable state, the final C/I value for each victim UE is determined.

After a certain number of snapshots, all the C/I data are statistical analysed to gain the system outage ratio.

According to the definition of system capacity, the system maximum number of users with and without $I_{UE,other}$, are determined based on the same 5% system outage criterion. The system capacity loss due to external UE interference is given by

$$C = 1 - \frac{N_{multi}}{N_{single}}$$

where N_{single} is the capacity for the single operator simulation and N_{multi} is the capacity for the multi operator simulation.

B.4 Simulation results

The capacity loss between single and multi operator simulation was determined for simulations with and without DCA. The capacity loss figures are given in the table below:

Table B.4: Simulation Results

Simulation Type	Capacity Loss
Without DCA	8.6 %
With DCA	1.6 %

As the capacity loss in the victim system was rather independent of the victim carrier within the 10 MHz block, the capacity loss is given as the average over all carriers of the victim operator.

¹⁰ See reference B.3.

B.5 Summary

Aim of the simulations was a first investigation of UE to UE interference in case of multiple unsynchronised TDD carriers in the 2.5 GHz band. The simulations are based on a uniform user distribution and on UE requirements as currently formulated in TS25.102. These first simulation results indicate that the capacity loss is more severe than with only a single interfering carrier, but not excessive. The results further indicate that the capacity loss can be significantly decreased, if dynamic channel allocation in the time domain is used. With DCA, a capacity loss below 2 % was observed.

In order to assess the impact of UE to UE interference and suitable RF requirements in more detail, further studies may be needed regarding the following aspects:

- Impact of larger cells sizes (577 m according to 25.942)
- impact from non-uniformly distributed UEs to the results
- Sensitivity to the relative timing of operators

B.6 Possible Future Study Areas

As mentioned already earlier, for already established operators providing UMTS services with the UMTS core band TDD in the 2500 – 2690 MHz band may be deployed as capacity enhancement. It is expected that the need for enhancements will mainly arise in limited areas such as city centers or hot spots like airports, railway stations or hotels, i.e. environments where UEs have a higher probability to be clustered in close proximity (see Figure B.4).

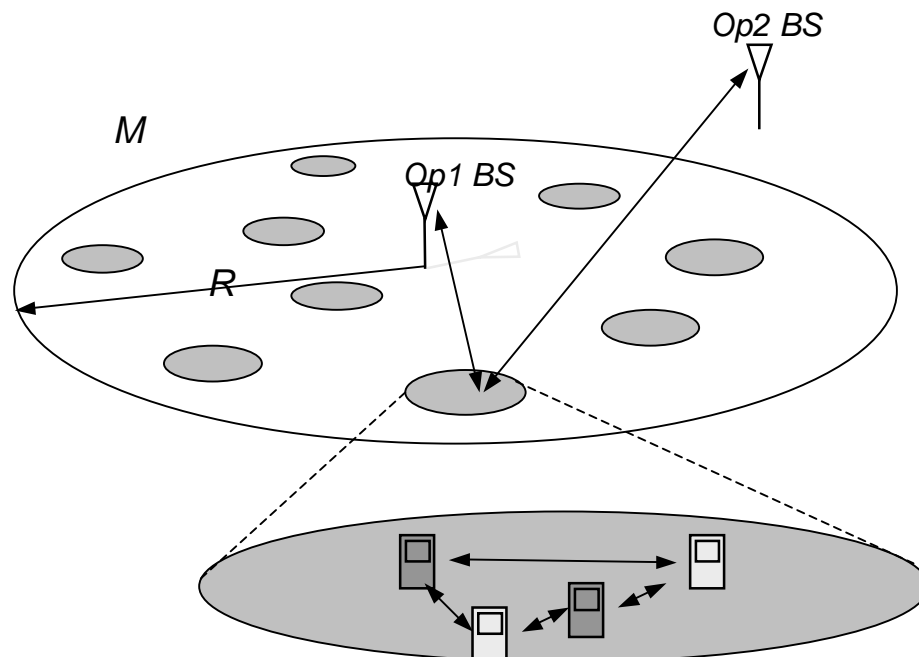

Figure B.4: A potential model for non-uniformly clustered UEs

Therefore, it may be also relevant in future studies to consider the impact from *non-uniformly* distributed UEs. However, before these kind of investigations can be performed, a corresponding model has to be developed in more detail. In particular, it has to be considered to what extent the clusters may be served by pico and micro cells. Further, in case high-density user clusters are taken into account it has to be mentioned that it has to be avoided that unrealistic user densities are simulated.

B.7 Reference

[B.1] Co-existence analysis of TD-SCDMA and WCDMA around 1920MHz-macro to macro scenario, Datang mobile, Dec. 2002, Tdoc for CWTS #14 WG1.

[B.2] Selection procedures for the choice of radio transmission technologies of the UMTS, (UMTS 30.03 version 3.2.0).

[B.3] 3GPP TR 25.942, RF System Scenarios.

[B.4] 3GPP TS 25.102, UE Radio Transmission and Reception (TDD)

[B.5] 3GPP TS 25.105, BS Radio Transmission and Reception (TDD)

[B.6] 3GPP TR 25.945, RF requirements for 1.28 Mcps UTRA TDD option

Annex C: Change history

TSG RAN WG4 #23: Version 1.0.0 approved to be presented to TSG RAN #16

TSG RAN#17: Version 1.1.0 was presented for information to TSG RAN#17 (RP-020657)

TSG RAN#18: Version 1.2.1 was presented for information to TSG RAN#18 (RP-020690)

Change history							
Date	WG #	WG Doc.	CR	Rev	Subject/Comment	Old	New
2002-08	24	R4-021153			Handover between cells with different duplex distances	1.0.0	1.1.0
2002-08	24	R4-021091			Signalling and control of the UE (RAN2) for Variable Duplex Spacing	1.0.0	1.1.0
2002-08	24	R4-021159			Considerations of RRM aspects in TR 25.889 V1.0.0 "Viable deployment of UTRA in additional and diverse spectrum arrangements"	1.0.0	1.1.0
2002-11	25	R4-021440			TR 25.889 v1.1.1	1.1.0	1.2.1
2002-11	25	R4-021509			Proposed amendments to the current draft TR 25.889 v1.1.0 "Feasibility Study considering the viable deployment of UTRA in additional and diverse spectrum arrangements"	1.1.0	1.2.1
2003-02	26	R4-030283			Text proposals for Section 7.1 of TR25.889 v1.2.1	1.2.1	1.3.0
2003-02	26	R4-030238			Scenarios of spectrum arrangements in 2500-2690MHz band	1.2.1	1.3.0
2003-02	26	R4-030190			Proposed new text for draft TR 25.889, clause 8 "Feasibility of UTRA TDD in the band 2500-2690 MHz"	1.2.1	1.3.0
2003-02	26	R4-030107			Text Proposal for Section 7.4 of TR 25.889 V1.1.0 "Viable deployment of UTRA in additional and diverse spectrum arrangements"	1.2.1	1.3.0
2003-02	26	R4-030106			Draft Text Proposal for Section 7.3 of TR 25.889 V1.1.0 "Viable deployment of UTRA in additional and diverse spectrum arrangements"	1.2.1	1.3.0
2003-02	26	R4-030189			TDD UE-UE Interference Simulations	1.2.1	1.3.0
2003-02	26	R4-030332			UE solutions for frequency band asymmetry	1.2.1	1.3.0
2003-05	27	R4-030598			TR 25.889 Conclusion Chapter (revised)	1.3.0	1.4.0