

# 3GPP TR 25.884 V2.0.0(2002-02)

---

*Technical Report*

**3<sup>rd</sup> Generation Partnership Project (3GPP);  
Technical Specification Group (TSG) RAN 3;**

**Iur Neighbouring Cell Reporting Efficiency Optimization  
(Release 5)**



Reference

---

<Workitem> (<Shortfilename>.PDF)

Keywords

---

<keyword[, keyword]>

**3GPP**

Postal address

---

Office address

---

Internet

---

secretariat@3gpp.org  
Individual copies of this deliverable  
can be downloaded from  
<http://www.3gpp.org>

---

**Copyright Notification**

---

No part may be reproduced except as authorized by written permission.  
The copyright and the foregoing restriction extend to reproduction in all media.

©  
All rights reserved.

---

# Contents

<b>1</b>	<b>SCOPE</b> .....	<b>5</b>
<b>2</b>	<b>REFERENCES</b> .....	<b>5</b>
<b>3</b>	<b>DEFINITIONS, SYMBOLS AND ABBREVIATIONS</b> .....	<b>5</b>
3.1	DEFINITIONS .....	5
3.2	SYMBOLS .....	5
3.3	ABBREVIATIONS .....	5
<b>4</b>	<b>INTRODUCTION</b> .....	<b>6</b>
<b>5</b>	<b>REQUIREMENTS</b> .....	<b>6</b>
<b>6</b>	<b>STUDY AREAS</b> .....	<b>6</b>
6.1	GENERAL.....	6
6.2	EFFICIENCY ANALYSIS OF THE CURRENT MECHANISM.....	6
	<i>Cell 'X' (cell where the RL is established)</i> .....	6
	<i>Neighbouring Cell Information</i> .....	7
	<i>Analysis outcome</i> .....	9
6.3	A POSSIBLE SOLUTION: THE CELL CONFIGURATION GENERATION ID-BASED MECHANISM.....	9
	<i>General</i> .....	9
	<i>Introduction of the Cell Configuration Generation Index (CCGI) concept</i> .....	9
	<i>CCGI Performance Analysis</i> .....	11
6.4	ANOTHER POSSIBLE SOLUTION: THE INFORMATION EXCHANGE-BASED MECHANISM.....	18
	<i>Information Exchange solution presentation</i> .....	18
	<i>Technical Details on the Information Exchange solution</i> .....	18
6.5	A THIRD POSSIBLE SOLUTION: THE CELL CAPABILITY CONTAINER APPROACH.....	21
6.6	OPEN ISSUES .....	22
<b>7</b>	<b>AGREEMENTS</b> .....	<b>22</b>
<b>8</b>	<b>SPECIFICATION IMPACT AND ASSOCIATED CHANGE REQUESTS</b> .....	<b>22</b>
<b>9</b>	<b>HISTORY</b> .....	<b>22</b>

---

# Intellectual Property Rights

---

## Foreword

This Technical Report (TR) has been produced by the 3<sup>rd</sup> Generation Partnership Project (3GPP), Technical Specification Group RAN.

The contents of this TR are subject to continuing work within 3GPP and may change following formal TSG approval. Should the TSG modify the contents of this TR, it will be re-released with an identifying change of release date and an increase in version number as follows:

Version m.t.e

where:

- m indicates [major version number]
- x the second digit is incremented for all changes of substance, i.e. technical enhancements, corrections, updates, etc.
- y the third digit is incremented when editorial only changes have been incorporated into the specification.

## 1 Scope

The purpose of the present document is to help the TSG RAN WG3 group to specify the changes to existing specifications, needed for the introduction of the Neighbouring Cells Reporting Optimization worktask., as proposed in [1].

The document describes the agreed requirements related to the worktask, the different areas that were studied, the agreements that were made, and it identifies the affected specifications with related Change Requests. It also describes the schedule of the worktask.

This document is a 'living' document, i.e. it is permanently updated and presented to all TSG-RAN meetings.

---

## 2 References

The following documents contain provisions which, through reference in this text, constitute provisions of the present document.

- References are either specific (identified by date of publication, edition number, version number, etc.) or non-specific.
- For a specific reference, subsequent revisions do not apply.
- For a non-specific reference, the latest version applies.
- A non-specific reference to an ETS shall also be taken to refer to later versions published as an EN with the same number.

[ 1. ] Work Item Description: "Iur Neighbouring Cell Reporting Efficiency Optimization" RP-010474, submitted at TSG RAN#12.

---

## 3 Definitions, symbols and abbreviations

### 3.1 Definitions

For the purposes of the present document, the following terms and definitions apply.

### 3.2 Symbols

### 3.3 Abbreviations

For the purposes of the present document, the following abbreviations apply:

## 4 Introduction

In R99 and R4, every time a new RL is established in a certain cell, the SRNC is provided with information about certain characteristics of cells neighbouring the cell where the radio link is established. However, this information is received by the SRNC regardless of the fact that the SRNC could possibly have received the same information before, i.e. as neighbouring cell information for a previous RL establishment. Therefore a work item was approved in order to study if mechanisms which can improve the reporting efficiency can be found and how to specify them. This technical report incorporates the identified requirements of such optimisation, the investigations carried out within TSG RAN3 and the agreements reached on possible mechanisms to increase the efficiency of the neighbouring cells reporting over Iur.

## 5 Requirements

The following requirements are identified:

- 1) Any solution shall enable a mechanism, by means of which neighbouring cell information is prevented from being signalled from the DRNC repeatedly when it is already known at the SRNC;
- 2) The solution shall have the least possible impact on the previous version of the affected specifications; implementations which support any new feature deriving from the solution of this problem shall be able to interoperate with implementations which don't have such support.

## 6 Study areas

### 6.1 General

This subclause describes the current situation of the Iur interface regarding to the problem presented in subclause 4 and on overview of possible solutions.

### 6.2 Efficiency analysis of the current mechanism

#### *Cell 'X' (cell where the RL is established).*

For FDD, the following information elements are related to the cell where the radio link is established. Beside each information element, an assessment is given on its static or dynamic characteristics, so that it is possible to quantify the gain in case this information, being sufficiently static, is not signalled repeatedly over Iur. The version of TS 25.423 that is assessed is 4.2.0.

CN PS Domain Identifier	O	static
CN CS Domain Identifier	O	static
>URA Information	O	static
>SAI	M	static
>Cell GAI	O	static
>UTRAN Access Point Position	O	static
>Received Total Wide Band Power	M	dynamic
>Secondary CCPCH Info	O	static
>DL Code Information	M	dynamic
>SSDT Support Indicator	M	static
>Maximum Uplink SIR	M	dynamic
>Minimum Uplink SIR	M	dynamic
>Closed Loop Timing Adjustment Mode	O	static
>Maximum Allowed UL Tx Power	M	dynamic
>Maximum DL TX Power	M	dynamic
>Minimum DL TX Power	M	dynamic
>Primary Scrambling Code	O	static
>UL UARFCN	O	static
>DL UARFCN	O	static
>Primary CPICH Power	M	static
>Cell GA Additional Shapes	O	static

For TDD and LCR TDD, in addition to the information already present for FDD, the following elements are specified:

<b>RL Information Response</b>		
>Cell Parameter ID	O	static
>Sync Case	O	static
>SCH Time Slot	C-Case2	static
>Block STTD Indicator	O	static
>PCCPCH Power	M	static
>Timing Advance Applied	M	static
>Alpha Value	M	static
>Secondary CCPCH Info TDD	O	static
<b>RL Information Response LCR</b>		
>UARFCN	O	static
>Cell Parameter ID	O	static
>Block STTD Indicator	O	static
>PCCPCH Power	M	static
>Alpha Value	M	static
>Secondary CCPCH Info TDD LCR	O	static

## Neighbouring Cell Information

### FDD Neighbouring Cell Information

For each RNC with neighbouring cells we have:

>RNC-Id	M	static
>CN PS Domain Identifier	O	static
>CN CS Domain Identifier	O	static

Then, for each neighbouring cell:

>C-Id	M	static
>UL UARFCN	M	static
>DL UARFCN	M	static
>Frame Offset	O	dynamic
>Primary Scrambling Code	M	static
>Primary CPICH Power	O	static
>Cell Individual Offset	O	static
>Tx Diversity Indicator	M	static
>STTD Support Indicator	O	static
>Closed Loop Mode1 Support Indicator	O	static
>Closed Loop Mode2 Support Indicator	O	static
>Restriction State Indicator	O	static

All this information is only related to one neighbouring cell and e.g. not related to the Cell x with one exception: the frame offset.

The frame offset is described as:

Required offset between the dedicated channel downlink transmission frames (CFN, Connection Frame Number) and the broadcast channel frame offset (Cell Frame Number). The Frame\_offset is used in the translation between Connection Frame Number (CFN) on Iub/Iur and least significant 8 bits of SFN (System Frame Number) on Uu. The Frame Offset is UE and cell specific.

As an example, let's take 2 cells in the same Node B. Both cells will have been configured over NBAP with a CELL-SETUP message, putting the start of the cell timing somewhere between 0 and 9 times 256 chips (Tcell) away from the BFN timing. This timing is shown in the following figure:

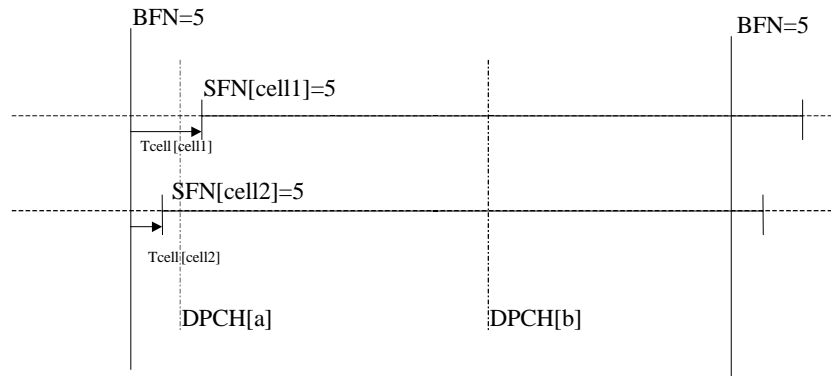

$$\text{BFN}(X+1) - \text{BFN}(X) = 38400 \text{ chips}$$

$$T_{\text{cell}} = 0, 256, 512, \dots, 2304 \text{ chips}$$

Two DPCHs (for 2 different UEs) are shown: DPCH[a] and DPCH[b]. Let's assume that in both cases the first RL is established in cell1, and the frame offset reported in the neighbouring cell info of this first RL concerns cell2; If we first look at DPCH[b], it is clear that at that location, the SFN of both cell 1 and 2 will be equal. As a result the reported frame offset is zero. In order to have two RLs aligned at that timing position, only the chip-offset will differ between cell1 and cell2.

However, if we look at DPCH[a], at that position there is a difference of 1 in the SFN value of cell1 and cell2. Assuming the first cell used a frame-offset of zero in order to calculate the CFN, the frame offset for cell2 will be 255. This means that the frame-offset is not only dependent on the cell relation, but also on the timing of the RL to the concerning UE. Given these dependencies, the frame offset is not a possible candidate for inclusion in a "static" cell configuration parameter set.

**TDD cells**

For each RNC with neighbouring cells we have:

>RNC-Id	M	static
>CN PS Domain Identifier	O	static
>CN CS Domain Identifier	O	static

Then, for each neighbouring cell:

>C-Id	M	static
>UARFCN	M	static
>Frame Offset	O	dynamic
>Cell Parameter ID	M	static
>Sync Case	M	static
>Time Slot	C-Case1	static
>SCH Time Slot	C-Case2	static
>Block STTD Indicator	M	static
>Cell Individual Offset	O	static
>DPCH Constant Value	O	static
>PCCPCH Power	O	static
>Restriction State Indicator	O	static

**LCR TDD cells**

For each RNC with neighbouring cells we have:

>RNC-Id	M	static
>CN PS Domain Identifier	O	static
>CN CS Domain Identifier	O	static

Then, for each neighbouring cell:



>C-Id	M	static
>UARFCN	M	static
>Frame Offset	O	dynamic
>Cell Parameter ID	M	static
>Block STTD Indicator	M	static
>Cell Individual Offset	O	static
>DPCH Constant Value	O	static
>PCCPCH Power	O	static
>Restriction State Indicator	O	static

### GSM cells

For each RNC with neighbouring cells we have:

>RNC-Id	M	static
>CN PS Domain Identifier	O	static
>CN CS Domain Identifier	O	static

Then, for each neighbouring cell:

> <b>CGI</b>		
>> <b>LAI</b>		
>>>PLMN Identity	M	static
>>>LAC	M	static
>>CI	M	static
>Cell Individual Offset	O	static
> <b>BSIC</b>		
>>NCC	M	static
>>BCC	M	static
>BCCH ARFCN	M	static
>Band Indicator	M	static

### Analysis outcome

It can be noticed from the above investigation, that much cell related information that is currently signalled over Iur in each response message at the establishment of a radio link is quite static, and therefore some efficiency optimisation is possible and needed. It has to be also considered that the gain is not really enormous when optimising the information related to Cell X (the one where the radio link is established), but there is still some gain. On the other hand there is a big gain when optimising the signalling of the neighbouring cell information.

A proper solution to this efficiency problem shall take into consideration a way to signal cell related information only when such information has gone through an update. It shall also consider the compatibility to the previous releases, so that the current mechanisms can coexist with the new improved ones.

## 6.3 A possible solution: the Cell Configuration Generation ID-based mechanism.

### General

This subclause discusses the possibility of adopting a smart/efficient mechanism to signal cell-related information over Iur in order to avoid redundant information being transferred to the SRNC.

#### *Introduction of the Cell Configuration Generation Index (CCGI) concept.*

The proposed solution is based on the concept of Cell Configuration Generation Index, an identifier that is associated to cell related information that can be considered sufficiently static.

When the SRNC requests the establishment of a new radio link in a certain cell, it will provide the DRNC with the latest value of the CCGI it is aware of for the concerned cell, or no value if the SRNC has no prior knowledge of configuration information related to that particular cell.

The DRNC can then compare its current CCGI for that cell with the one that was provided by the SRNC in the request message and find out if the SRNC has up-to-date information about that cell or not.

If nothing has changed, no information associated to the CCGI needs to be included in the response message, otherwise CCGI related information can be included together with a new (updated) CCGI value.

The following figures illustrate the mechanism enabled by the introduction of the Cell Configuration Generation Index, without pointing towards a particular implementation. This mechanism gives the possibility to make the cell information related signalling more efficient.

In this solution there would be one Cell Configuration Generation Index (CCGI) for cell attributes of a cell. The attributes covered by the CCGI are:

- The static attributes of the accessed cell (the cell where an RL is being established) that are:
  - a) optional,
  - b) not conditioned by the presence of D-RNTI (RL Setup procedure; in R'99, R4, and R5 attributes normally provided to the SRNC as part of the neighbouring cell information), and
  - c) typically configured and not changed so frequently.
- The attributes of the cells neighbouring the accessed cell except the ones that are typically assigned values based on the current connection with the UE, e.g., Frame Offset for FDD neighbouring cells.

The attributes of the cells neighbouring the accessed cell not covered by the CCGI<sup>1</sup> will be sent in a new IE to avoid sending attributes covered by the CCGI just because they are mandatory parts of the current neighbouring cell information IEs.

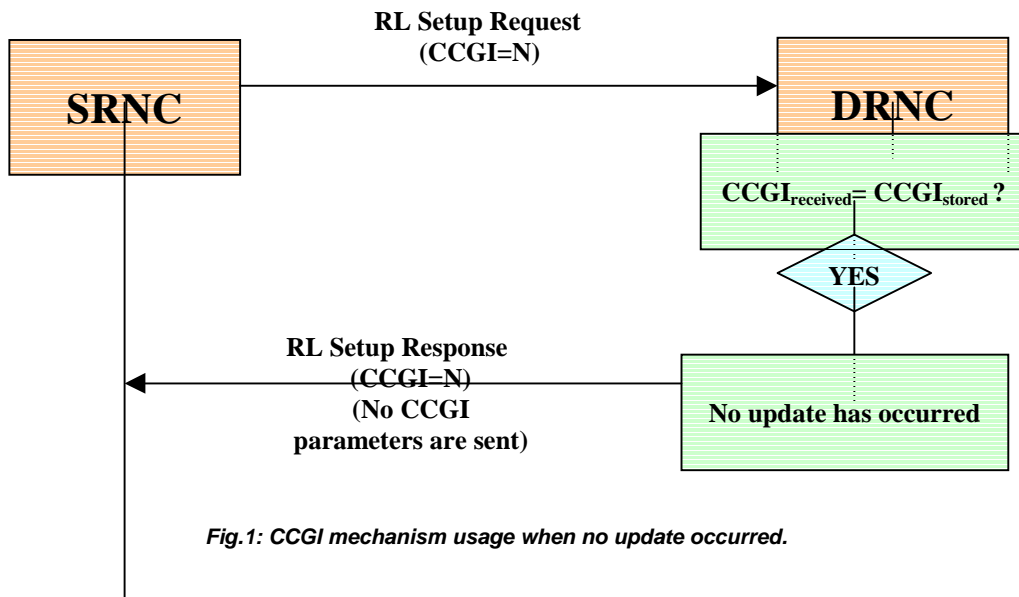

Fig.1: CCGI mechanism usage when no update occurred.

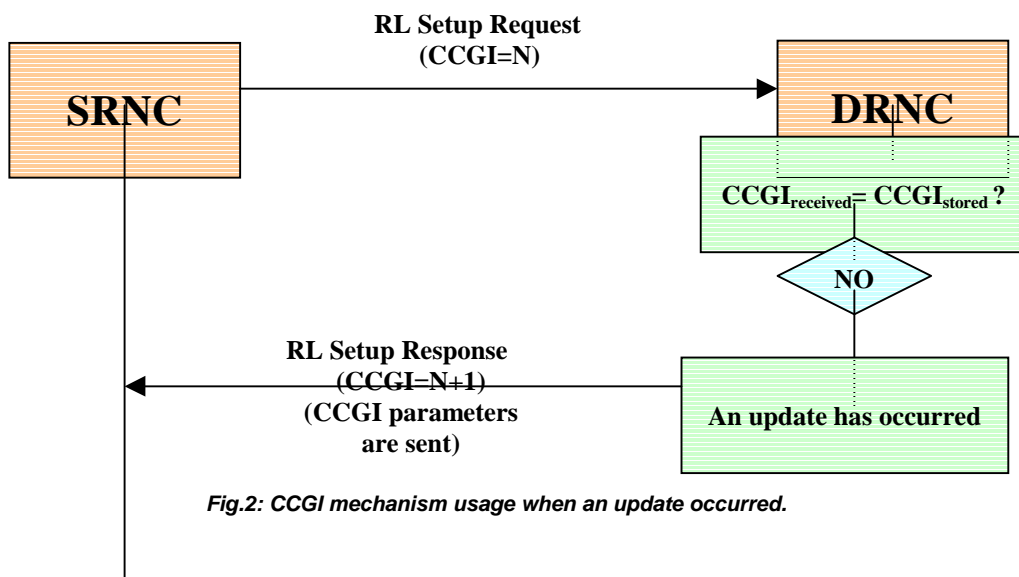

Fig.2: CCGI mechanism usage when an update occurred.

<sup>1</sup> The attributes that are typically assigned values based on the current connection with the UE.

## CCGI Performance Analysis

### 6.3.1.1 CCGI Size

It is considered that the size of the CCGI is not really a critical choice, however it should not be too small, in order to have a sufficient number of values before the counter restarts, and not too big, so that the achieved gain is not impacted. A reasonable length for the CCGI is thus considered to be equal to *1 byte*. The CCGI have to be included in a protocol container since it is a new IE. The total size will then be 5 bytes (4 for the container).

### 6.3.1.2 Comparison between CCGI and replaced information length

#### 6.3.1.2.1 FDD Cell Information

For an accessed FDD cell the CCGI would correspond to the following **optional** cell level parameters, normally provided as cell attributes of a cell where a RL is being established:

Information Element	ASN.1 Type	Size [bytes]
URA Information	INTEGER (65536) + ENUMERATED with 2 values (no extension) + number of RNCs in URA * INTEGER (4096)	$2 \frac{1}{8}^2$
Cell GAI	Number of points * [ENUMERATED with 2 values (no extension) + INTEGER ( $0..2^{23}-1$ ) + INTEGER ( $-2^{23}..2^{23}-1$ )]	$X*[1/8 + 3 \frac{7}{8} + 4] = 24^3$
UTRAN Access Point Position	ENUMERATED with 2 values (no extension) + INTEGER ( $0..2^{23}-1$ ) + INTEGER ( $2^{23}..2^{23}-1$ )	$8 \frac{1}{8}$
Secondary CCPCH Info <sup>4</sup>	? <sup>5</sup>	? <sup>5</sup>
Closed Loop Timing Adjustment Mode	ENUMERATED with 2 values (extensible)	$1/8$ (inside the defined range)

<sup>2</sup> Assuming no other RNC controlling cells in the URA (should be close to a reasonable average).

<sup>3</sup> Assuming 3 points in the Cell GAI (the minimum number of points to describe an area).

<sup>4</sup> Used for DRAC controlled cells.

<sup>5</sup> The ASN.1 type and the actual size largely depend on the configuration of the DRAC function. In this investigation no opinion on what a reasonable or the most commonly used configuration is.

Information Element	ASN.1 Type	Size [bytes]
Cell GAI Additional Shapes	CHOICE (extensible) of : (1) [ENUMERATED with 2 values (no extension) + INTEGER (0..2 <sup>23</sup> -1) + INTEGER (-2 <sup>23</sup> ..2 <sup>23</sup> -1)] + INTEGER (0..127) OR (2) [ENUMERATED with 2 values (no extension) + INTEGER (0..2 <sup>23</sup> -1) + INTEGER (-2 <sup>23</sup> ..2 <sup>23</sup> -1)] + [INTEGER (0..127) + INTEGER (0..127) + INTEGER (0..179)] + INTEGER (0..127) OR (3) [ENUMERATED with 2 values (no extension) + INTEGER (0..2 <sup>23</sup> -1) + INTEGER ((-2 <sup>23</sup> ..2 <sup>23</sup> -1)] + [ENUMERATED with 2 values (no extension) + INTEGER (0..2 <sup>15</sup> -1)] + INTEGER (0..127) OR (4) [ENUMERATED with 2 values (no extension) + INTEGER (0..2 <sup>23</sup> -1) + INTEGER (-2 <sup>23</sup> ..2 <sup>23</sup> -1)] + [ENUMERATED with 2 values (no extension) + INTEGER (0..2 <sup>15</sup> -1)] + [INTEGER (0..127) + INTEGER (0..127) + INTEGER (0..179)] + INTEGER (0..127) + INTEGER (0..127) OR (5) [ENUMERATED with 2 values (no extension) + INTEGER (0..2 <sup>23</sup> -1) + INTEGER (-2 <sup>23</sup> ..2 <sup>23</sup> -1)] + INTEGER (0..2 <sup>16</sup> -1) + INTEGER (0..127) + INTEGER (0..179) + INTEGER (0..179) + INTEGER (0..127)	3/8 + Choice of : 8 7/8 OR 11 5/8 OR 10 OR 14 4/8 OR 13 6/8  (plus 4 bytes due to the extra protocol container needed for this IE)

The above information represents (2.250 bytes + size of Area/point IE):

- 10.375 bytes including UTRAN Access Point Position
- 15.500 bytes (at least<sup>6</sup>) including Cell GAI Additional Shapes
- 26.250 bytes including Cell GAI<sup>3</sup>
- 23.625 bytes (at least<sup>7</sup>) including UTRAN Access Point Position and Cell GAI Additional Shapes
- 34.375 bytes including UTRAN Access Point Position and Cell GAI<sup>3</sup>

Note 1. The Uplink SIR Target (only RL SETUP RESPONSE/FAILURE) would not be represented by the CCGI since it is typically dynamically set for each RL:

Note 2. The following optional parameters (also provided on the cell level) would not be represented by the CCGI since they are normally provided to the SRNC as cell attributes of a neighbouring cell, see further below:

- Primary Scrambling Code
- UL UARFCN
- DL UARFCN

<sup>6</sup> The size depends on the choice of which shape to include in the *Cell GAI Additional Shapes* IE.

<sup>7</sup> The size depends on the choice of which shape to include in the *Cell GAI Additional Shapes* IE. This size corresponds to having a point with uncertainty in the *Cell GAI Additional Shapes* IE. Note that it does not really make sense to have this shape in combination with the UTRAN Access Point Position.

6.3.1.2.2 FDD Neighbouring Cell Information

For the neighbouring cells level of the accessed cell the CCGI would correspond to the following parameters, normally provided as cell attributes of a neighbouring FDD cell (the corresponding list exist for neighbouring TDD cells) where a RL is being established:

Information Element	ASN.1 Type	Size [bytes]
UL UARFCN	INTEGER (0..16383,...)	15/8 (inside the defined range)
DL UARFCN	INTEGER (0..16383,...)	15/8 (inside the defined range)
Primary Scrambling Code	INTEGER (0..511)	9/8
Primary CPICH Power	INTEGER (-100..500)	10/8
Cell Individual Offset	INTEGER (-20..20)	6/8
Tx Diversity Indicator	ENUMERATED with 2 values (no extension)	1/8
STTD Support Indicator	ENUMERATED with 2 values (no extension)	1/8
Closed Loop Mode1 Support Indicator	ENUMERATED with 2 values (no extension)	1/8
Closed Loop Mode2 Support Indicator	ENUMERATED with 2 values (no extension)	1/8
Restriction State Indicator	ENUMERATED with 2 values (extensible)	2/8 (inside the defined range)  (plus 4 bytes due to the extra protocol container needed for this IE)

The above information represents 11.625 bytes.

Note! The Frame Offset (1 byte) would not be represented by the CCGI since it is calculated individually for each UE.

In addition to the cell attributes of a neighbouring cell the following is provided for each RNC (other than the DRNC) with neighbouring cells:

Information Element	ASN.1 Type	Size [bytes]
CN PS Domain Identifier	OCTET STRING (SIZE (3)) + OCTET STRING (SIZE (2))	5
CN CS Domain Identifier	OCTET STRING (SIZE (3)) + OCTET STRING (SIZE (2)) + OCTET STRING (SIZE(1))	6

The above information represents 11 bytes.

6.3.1.2.3 GSM Neighbouring Cell Information

For the GSM neighbouring cells the CCGI would replace all the GSM Neighbouring Cell Information since this is an optional IE containing only static parameters. The GSM Neighbouring Cell Information consists of:

Information Element	ASN.1 Type	Size [bytes]
CGI	OCTET STRING (SIZE(3)) + OCTET STRING (SIZE(2)) + OCTET STRING (SIZE(2))	7
Cell Individual Offset	INTEGER (-20,...,+20)	5/8
BSIC	BIT STRING(3) + BIT STRING(3)	6/8
BCCH ARFCN	INTEGER (0..1023)	10/8
Band Indicator	Enumerated (2 values) extensible	2/8

The above information represents 9.875 bytes. Since the GSM Neighbouring Cell Information is completely replaced by the CCGI also the 4-byte overhead from the protocol container can be omitted when the received CCGI is valid. This means that the total number of bytes represented by the CCGI is 13.875.

6.3.1.2.4 Summary

Assume a one byte CCGI and non-static cell attributes (currently only the Frame Offset) being reported per neighbouring FDD cell (with C-ID). This results in the following increase/reduction of information transferred on the Iur interface:

• RL SETUP/ADDITION REQUEST

In these messages the CCGI of each accessed cell would be sent corresponding to an increase of 5 bytes per cell where an RL is being established.

RL SETUP/ADDITION RESPONSE/FAILURE

When the CCGI received is the current ones there would be a reduction of 34.375 bytes per cell<sup>2-32.3</sup> (assuming that the cell is not DRAC controlled), 11.625 bytes per FDD neighbouring cell, 13.825 bytes per GSM neighbouring cell, and 11 bytes per RNC (other than the DRNC) controlling the FDD neighbouring cells in the response/failure message.

Note! The above estimate does not take into account the full ASN.1 structure, so the effect of i.e. ‘indicators for optional IEs’. The gain would consequently increase somewhat if the full ASN.1 structure is analysed.

6.3.1.3 Gain from the CCGI Mechanism

Given the above results, we can see how the reduction of information transfer on Iur becomes more and more significant with an increasing number of neighbouring cells.

The following notation is used in the diagrams:

- (DRNC) The DRNC controls all neighbouring cells.
- (1 RNC) Some of the neighbouring cells are controlled by another RNC than the DRNC.
- (4 RNCs) Some of the neighbouring cells are controlled by other RNCs (4 in total) than the DRNC.

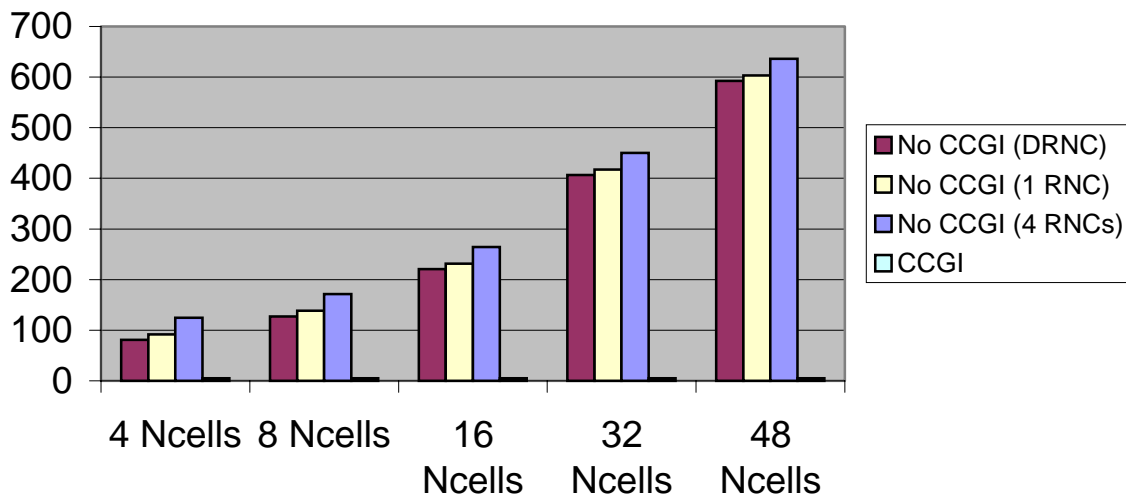

Fig.3: Accessed FDD cell with only FDD N-Cells: Number of bytes transferred of cell and neighbouring cell information on Iur vs. number of neighbouring cells with and without the CCGI mechanism. (note that the column for “CCGI” is barely visible in the diagram)

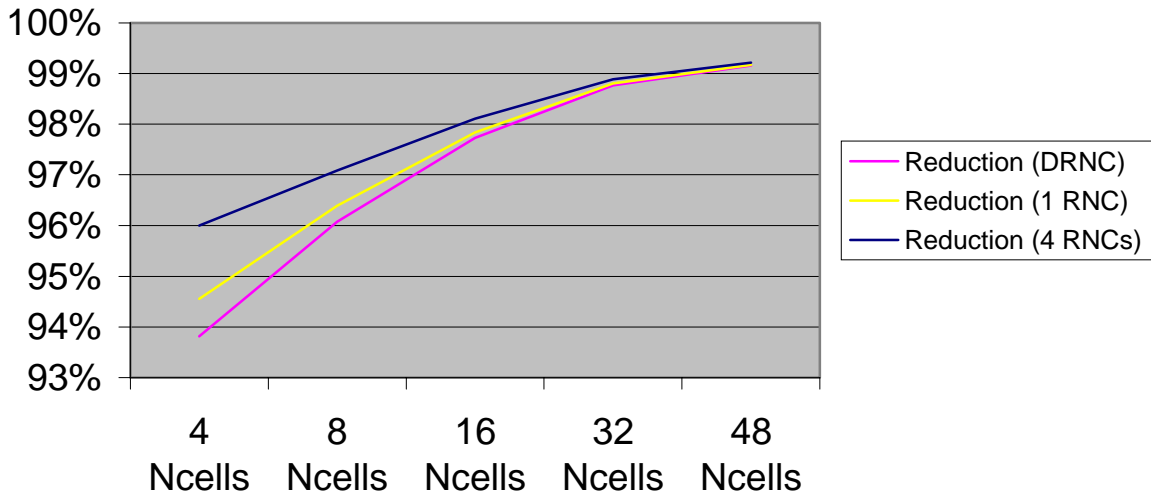

Fig.4: Accessed FDD cell with only FDD N-Cells: Reduction in transfer of cell and neighbouring cell information on Iur using the CCGI mechanism.

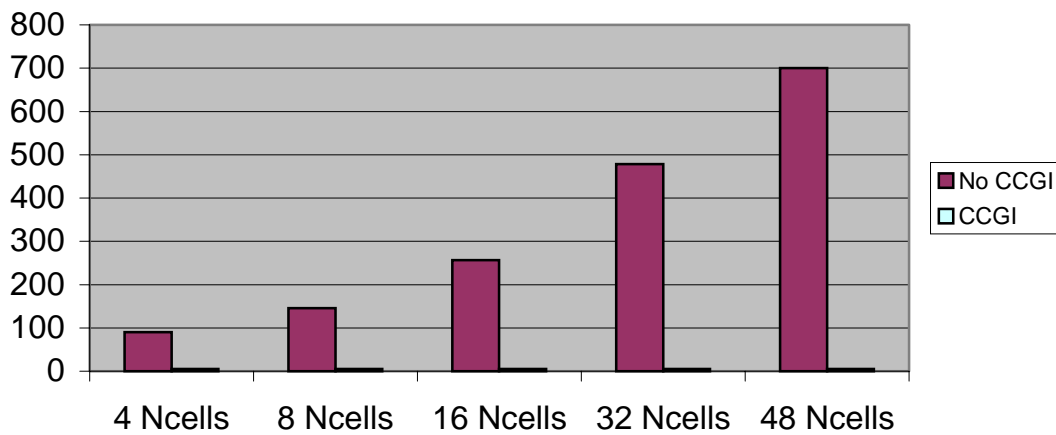
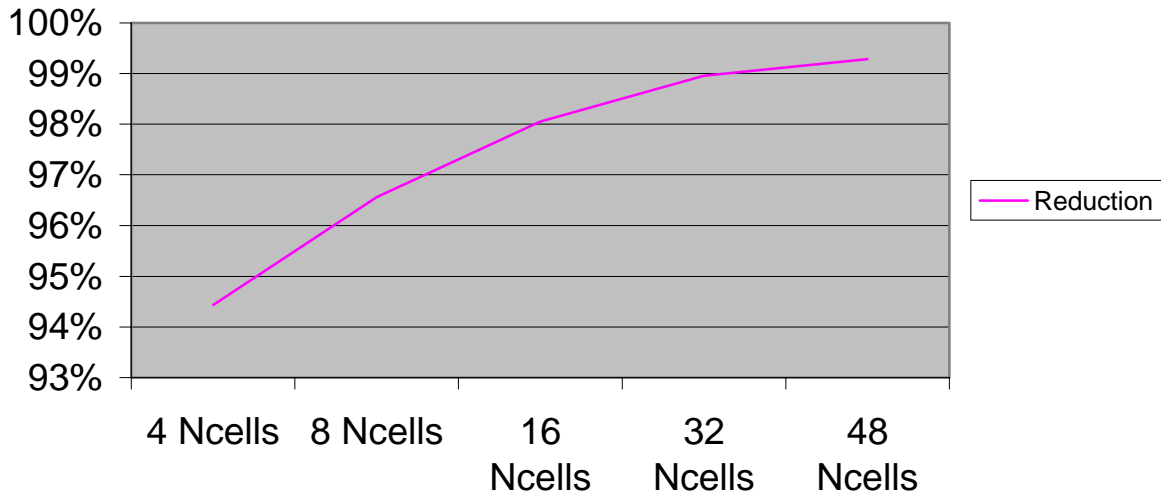

Fig.5: Accessed FDD cell with only GSM N-Cells: Number of bytes transferred of cell and neighbouring cell information on Iur vs. number of neighbouring cells with and without the CCGI mechanism. (note that the column for “CCGI” is barely visible in the diagram).



**Fig.6: Accessed FDD cell with only GSM N-Cells: Reduction in transfer of cell and neighbouring cell information on Iur using the CCGI mechanism.**

The above diagrams show the reduction in information transfer in relation FDD and GSM Neighbouring cells. The amount of information transferred for TDD and LCR TDD neighbouring cells is fairly similar to the FDD information thus a similar gain can be expected.

Putting these numbers into an example with the following configuration:

- 2 FDD frequency layers
- complete overlay of GSM cells (coinciding in coverage)
- each FDD cell has 6 intra-frequency neighbouring cells
- each FDD cell has 7 inter-frequency neighbouring cells
- all the FDD cells are controlled by the same RNC (the DRNC)
- Additional assumptions<sup>8</sup>:
  - no other RNC controlling cells in the URA
  - no cell in the DRNC is controlled by DRAC
  - the UTRAN Access Point Position and Cell GAI are part of the cell attributes with 3 points in the Cell GAI (the minimum number of points to describe an area)
  - the parameters with extensible value ranges are within the initial value range

This gives in total 20 neighbouring cells (6+7 FDD and 7 GSM). With one accessed FDD Cell the reduction in information transferred over Iur due to the accessed cell and these neighbouring cells is 205 bytes<sup>9</sup> corresponding to 97.6% using the CCGI mechanism.

Considering possible deployment scenarios, we can see that for example in case of shared network scenarios with many operators present in the same region, the number of neighbouring cells could be extremely significant.

#### 6.3.1.3.1 Bandwidth Saving

The amount of bandwidth saving is to some extent dependent on network configuration (number of Ncells/cell, number of RNCs controlling the Ncells, number of cells/procedure, etc.), feature support (DRAC, etc.), etc. However, using the example network described in the previous subclause the following bandwidth saving is achieved.

<sup>8</sup> All these assumption reduces the gain somewhat.

<sup>9</sup> 5 bytes transferred in the RL SETUP/ADDITION REQUEST message instead of 210 bytes in the RL SETUP/ADDITION RESPONSE message.



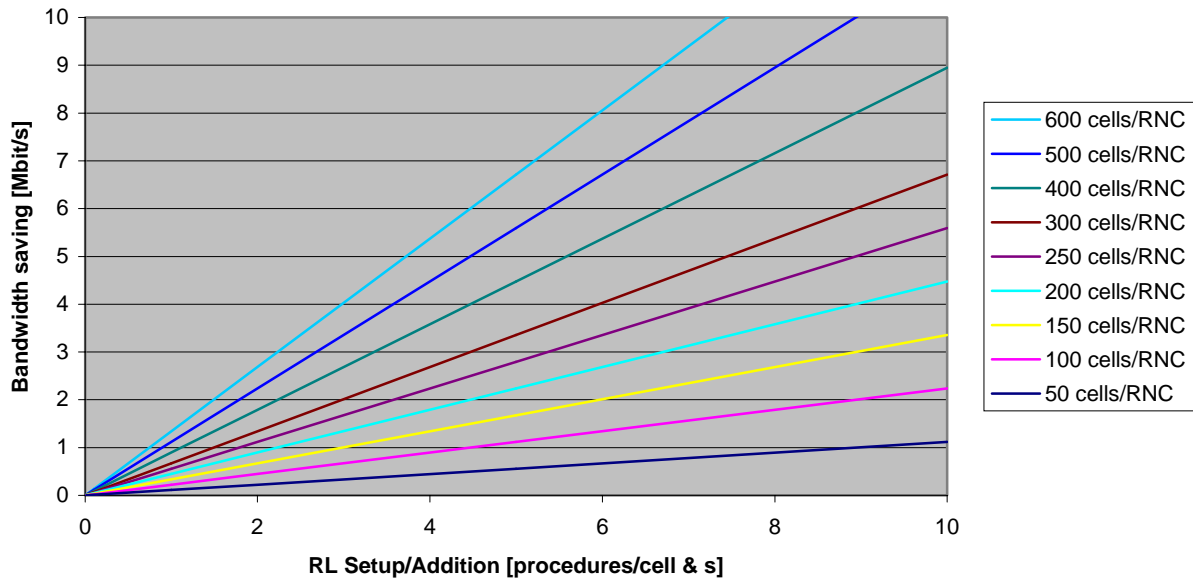

Fig.7: Bandwidth saving on Iur using the CCGI mechanism.

Note! The left part of the figure is assumed to be the most realistic one in actual network configuration (0-2 setups/cells/second). It should also be noted that this figure shows the absolute gain whereas the relative gain can be said to be a more significant aspect.

#### 6.3.1.3.2 Impact on Memory Usage

It has been argued that the CCGI mechanism increases the need for memory in an SRNC. However, this is not true. Some alternative methods of storing the cell/neighbouring cell Information in the SRNC are the following:

1. As currently the cell and “list of” neighbouring cell information is stored for every UE Context in the SRNC (without any CCGI).
2. Each cell and “list of” neighbouring cell information is stored once (per CCGI) in the SRNC and maintained as long as there is at least one active UE Context using the information.
3. Each cell and “list of” neighbouring cell information is stored once (per CCGI) in the SRNC and maintained as long as there is at least one active UE Context using the information. When no active UE Context is using the information a timer is started. At timer expiry the cell and “list of” neighbouring cell information is removed from the SRNC memory.
4. As 3 above but maintaining the 10, 20, 100, ... most commonly accessed cells/Ncells.
5. As 3 above but maintaining the 10, 20, 100, ... most recently accessed cells/Ncells.

Each of the methods 2-5 above can easily be used to reduce the memory usage requirement on the SRNC with the only exception the if there are almost no commonly used cells at all then there is no memory gain and in extreme cases even a slight increase (requires that each cell and “list of” neighbouring cell information stored is only needed by one UE Context) in memory utilisation. The worst case is 1 extra byte (the CCGI) per UE Context and Radio Link.

Assume the configuration example in the previous subclause. In this configuration memory usage reduction is possible using the CCGI mechanism if there are more than (on an average) roughly 1.005 UE Contexts<sup>10</sup> using a cell and “list of” neighbouring cell information represented by a CCGI.

Note! If there were in contrast to this solution one CCGI per neighbouring cell the memory need would be even more reduced.

#### 6.3.1.3.3 Impact on Processing Power

When utilising the advantage of the CCGI mechanism to store the information related to a certain cell and CCGI only once there is also reduction in processing power needed to analyse the received cell and neighbouring cell information. Currently whenever the SRNC receives cell related information, it has to analyse it in order to make decisions, while if the SRNC is provided with an a priori knowledge that nothing has changed it can avoid doing the analysis as long as it considers the CCGI valid. This saves processing power.

<sup>10</sup> The information (not including the bytes for the IE containers transferred on Iur) corresponding to the CCGI is 198 bytes (per RL). The CCGI is 1 byte. This means that stored for one UE Context there would be 199 bytes with the CCGI solution and 198 bytes without it. If there are 1.005 UE Contexts using the information represented by the CCGI then each UE Context will require 198 bytes of memory (199/1.005).

#### 6.3.1.3.4 Possible performance improvement given the current standardisation trend

Lately, in RAN3, we have seen an increasing number of cell related information being added to the Neighbouring Cell Information over Iur, like for example the Restriction State Indicator for the feature 'Cell Reserved for Operator's Use', one of the solutions under discussion for network sharing and the Flexible Hard Split Support Indicator for DSCH Hard Split Mode. It was also discussed in meeting #23 if RAN3 should adopt a cell classmark approach to take this type of information into consideration, showing the increasing amount of static cell related information that is being specified. It can be seen that this is information whose Iur signalling could possibly be optimised with an efficiency improvement mechanism like the CCGI based one. Therefore it can be said that *'the benefits of the CCGI mechanism become more and more important in a future perspective'*.

Note! New cell and neighbouring cell attributes are added in extension containers of the protocol, either individually or grouped together. This further adds to the size of the new attributes. (Each protocol container adds a 4-byte overhead.)

#### 6.3.1.4 Conclusions

It is concluded that the CCGI mechanism outlined in this document provides significant gains with respect to:

- a) reduced memory need in the SRNC,
- b) reduced processing power for message analysis and decisions in the SRNC, and
- c) reduced information transfer.

There are further more some gains with respect to bandwidth utilisation.

However, memory is relatively inexpensive and the gains in processing power are difficult to quantify so these gains may be less important.

Finally, it is concluded that the outlined CCGI mechanism provides a general mechanism that effectively reduces the information transfer on Iur of current and future cell/neighbouring cell attributes that are "static".

## 6.4 Another possible solution: the Information Exchange-based mechanism

### *Information Exchange solution presentation*

In Release 4, the "Information Exchange"-related procedures was introduced over Iur to allow the support of the UE Positioning Release 4 methods (OTDOA and A-GPS). The design of these procedures and the related messages is based on the design of the "Dedicated/Common Measurement"-related procedures. This set of procedures allows to collect information on a given Cell (object of the request) with an Event Type which is "On Demand", "Period" or "On Modification".

It is believed that the existing procedures could be easily enhanced to allow an RNC to provide information on a given Cell such as those available in the *Neighbouring UMTS/FDD/TDD/GSM Cells Information* IEs.

Furthermore, it is believed that enhancing the Information Exchange procedures is sufficient in order to achieve most, if not all, of the signalling gain. In fact, the major part of the signalling gain will be obtained for Cells on which such information is frequently provided (for instance, numerous Radio Links are established on these Cells). As these Cells are well known to the RNC, once the RNC has set up the Information Exchange procedure for a given Cell with the Event Type set to "On Modification", it is assured to have access to the most up-to-date information on the Cell. Thus, all that is needed is a flag in the relevant messages to indicate that "static" information on the Cell is not needed.

### *Technical Details on the Information Exchange solution*

#### *"Simple I-Ex" solution*

The RNC should consider that all the needed information on the Cell is available if it has successfully initiated:

- an Information Exchange procedure with an "On Modification" Event type for the considered Cell in order to obtain the Complete Cell Information.

#### Impacts on the Radio Link Setup/Addition procedures:

It is necessary to include the *Cell Information Already Available* optional IE in the RADIO LINK SETUP/ADDITION REQUEST messages.

If the *Cell Information Already Available* IE is present in the message, then the DRNC does not need to provide the IEs identified in section 6.3.5.

In this case, similar modifications to the concerned procedure texts as those outlined in the section 6.3.7 for the Response messages are needed, except that only the presence of the *Cell Information Already Available* IE acts as a trigger to determine the inclusion or not of such an information (no need for other verifications as for the CCGI).

If the *Cell Information Already Available* IE is not present in the message, then the DRNC shall behave normally (send the identified IEs if specified).

#### Impacts on the Information Exchange procedure:

As the "Cell" Information Exchange Object Type already exists, it is possible to only extend the enumeration in the *Information Type* IE to contain different "Cell Information" values:

**Modifications to TS 25.423 v4.2.0**

9.2.1.31E Information Type

The Information Type indicates which kind of information the RNS shall provide.

IE/Group Name	Presence	Range	IE Type and Reference	Semantics Description
Information Type Item	M		ENUMERATED (UTRAN Access Point Position with Altitude, IPDL Parameters, GPS Information, DGPS Corrections, GPS RX Pos, SFN-SFN Measurement Reference Point Position, ..., Cell Information)	
<b>GPS Information</b>	C-GPS	1..<maxnoofGPSTypes>		
>GPS Information Item			ENUMERATED (GPS Navigation Model and Time Recovery, GPS Ionospheric Model, GPS UTC Model, GPS Almanac, GPS Real-Time Integrity, ...)	
<b>Cell Information</b>	C-Cell	1..<maxnoofCellTypes>		
>Cell Information Item			ENUMERATED (Complete Cell Information, ...)	

Condition	Explanation
GPS	This IE shall be present if the <i>Information Type</i> IE indicates 'GPS Information'
Cell	This IE shall be present if the <i>Information Type</i> IE indicates 'Cell Information'

Range Bound	Explanation
MaxnoofGPSTypes	Maximum number of GPS Information Types supported in one Information Exchange.

The *Requested Data Value* IE can be extended to include the Complete Cell Information, i.e.:

- information usually contained in the Neighbouring Cell Information IEs for the considered Cell
- All the *Neighbouring UMTS/GSM Cells Information* IE for all the neighbouring Cells of the considered Cell.

Impacts on the Uplink Signalling Transfer procedures:

With such a mechanism, it is possible to specify in the DRNC behaviour that if an Information Exchange Initiation procedure has been successfully performed for the concerned Cell with the "On-Modification" event, then there is no need to include all the optional *Indicator* IEs in the UPLINK SIGNALLING TRANSFER message. As the system evolves more and more of these indicators will appear in the signalling and it could be useful to reduce their usage in each message, thus retaining the primary intention for creating such a message.

**"Enhanced I-Ex" solution**

The RNC should consider that all the needed information on the Cell is available if it has successfully initiated:

- an Information Exchange procedure with an "On Modification" Event type for the considered Cell in order to obtain the Cell Information and the Neighbouring Cells List,
- an Information Exchange procedure with an "On Modification" Event type for each UMTS Cell present in the Neighbouring Cells List of the considered Cell in order to obtain their Cell Information.

Impacts on the Radio Link Setup/Addition procedures:

Same as in section 6.4.3.

Impacts on the Information Exchange procedure:

Same as in section 6.4.3, except:

>Cell Information Item			ENUMERATED (Neighbouring UMTS Cells List, Cell Information, ...)	
------------------------	--	--	---	--

The *Requested Data Value* IE can be extended to include:

- the Neighbouring UMTS Cells list
- the Cell Information, i.e.:
  - information usually contained in the *Neighbouring FDD/TDD Cell Information* IEs for the considered Cell,
  - *Neighbouring GSM Cells Information* IE for all the neighbouring GSM Cells of the considered Cell).

Impacts on the Uplink Signalling Transfer procedures:

Same as in section 6.4.3.

Advantage compared to the "Simple I-Ex" solution:

In the "Simple I-Ex" solution as well as in the "CCGI-based" solution, information concerning a given Cell (Cell A) will be provided for each Cell of which Cell A is a neighbour. Furthermore, each time, information about the Cell A changes, the Complete Cell Information (or the CCGI) of all the Cells of which Cell A is a neighbour has changed, which generates also more signalling.

Thus, the "Enhanced I-Ex" solution allows to reduce even more the amount of signalling as information relevant to a given Cell will be provided only once to a given RNC, through an Information Exchange dedicated to that purpose.

Note: For the time being, there is no way to realise such an enhancement for Neighbouring GSM Cells. Perhaps with an Information Exchange over the Iur-g...

*Extensibility of either solution*

It is easy to envisage with such a mechanism the possibility to transfer other useful information about the Cell such as the status of the Cell and objects in this Cell (for instance, the FACH/RACH states, for the SRNC to know if Cell-DCH to Cell-FACH transition is possible in this Cell).

## 6.5 A third possible solution: the Cell Capability Container approach

In this solution a container is added to the relevant messages in order to group capability indicators related to a certain cell or to neighbours of the accessed cell. This container can be used to indicate supported functionality in general. This solution reduces also the size of future “capability indicators” thereby reducing the size increase of the Release 5 and future cell attributes (given that looking at the additions made to neighbouring cell signalling in release-4 and the expected changes for release-5, extensions for indicating cell capabilities seems to be the main area for additions). Below it’s an example of possible inclusion of Cell Capability Container in the Uplink Signalling Transfer message (FDD); the same information would also be included in the Neighbouring FDD, TDD and LCR TDD cell information.

### 9.1.24 UPLINK SIGNALLING TRANSFER INDICATION

#### 9.1.24.1 FDD Message

IE/Group Name	Presence	Range	IE type and reference	Semantics description	Criticality	Assigned Criticality
Message Type	M		9.2.1.40		YES	ignore
Transaction ID	M		9.2.1.59		–	
UC-Id	M		9.2.1.71		YES	ignore
SAI	M		9.2.1.52		YES	ignore
Cell GAI	O		9.2.1.5A		YES	ignore
C-RNTI	M		9.2.1.14		YES	ignore
S-RNTI	M		9.2.1.54		YES	ignore
D-RNTI	O		9.2.1.24		YES	ignore
Propagation Delay	M		9.2.2.33		YES	ignore
STTD Support Indicator	M		9.2.2.45		YES	ignore
Closed Loop Mode1 Support Indicator	M		9.2.2.2		YES	ignore
Closed Loop Mode2 Support Indicator	M		9.2.2.3		YES	ignore
L3 Information	M		9.2.1.32		YES	ignore
CN PS Domain Identifier	O		9.2.1.12		YES	ignore
CN CS Domain Identifier	O		9.2.1.11		YES	ignore
URA Information	O		9.2.1.70B		YES	ignore
Cell GA Additional Shapes	O		9.2.1.5B		YES	ignore
DPC Mode Change Support Indicator	O		9.2.2.56		YES	ignore
Cell Capability Container FDD	O		9.2.2.xx		YES	ignore
Cell Capability Container TDD	O		9.2.3.xx		YES	ignore
Cell Capability Container TDD LCR	O		9.2.3.xx		YES	ignore

The Cell Capability Container is a bitstring type and it is forward compatible by means of assigning undefined bits (representing future capabilities not yet specified) as Spare Bits, with the requirement that such bits be set to zero by the sender and ignored by the receiver.

The impact of this solution to the specifications is extremely limited, given that it consists of a more efficient grouping of capabilities in a container that should anyway be adopted for the introduction of each single capability group in each release.

An example of possible definition of the Cell Capability Container, here illustrated for the TDD case, follows below.

#### 9.2.1.YY CELL CAPABILITY CONTAINER TDD

The Cell Capability Container TDD indicates which functionalities a cell supports.

IE/Group Name	Presence	Range	IE type and reference	Semantics description
Cell Capability Container TDD			BIT STRING (32)	Each bit indicates whether a cell supports a particular functionality or not. The value 1 of a bit indicates that the corresponding functionality is supported in a cell and value 0 indicates that the corresponding functionality is not supported in a cell. Each bit is defined as follows:.... Note that undefined bits are considered as a spare bit and spare bits shall be set to 0 by the transmitter and shall be ignored by the receiver.

## 6.6 Open issues

None.

## 7 Agreements

The following conclusions were agreed:

1. It was agreed to adopt the solution described in subclause 6.5.

## 8 Specification Impact and associated Change Requests

This clause lists places where Change request need to be given in order to enhance Release 4 specification to Release 5 specification for this work task.

**Table 1: Place where Change request is given in order to refer the new procedure**

3G TS	CR	Title	Remarks
25.423	553	Introduction of cell capability container over Iur	

## 9 History

Document history		
V0.0.1	2001-08	First proposed version
V0.1.0	2001-08	Version agreed at RAN3 #23
V.0.1.1	2001-11	Rapporteur's proposal reflecting agreements made at RAN3#24
V.0.2.0	2001-11	Version agreed at RAN3 #25
V.0.2.1	2002-02	Rapporteur's proposal reflecting agreements made at RAN3#26
V.0.3.0	2002-02	Version agreed at RAN3 #27
V.0.3.1	2002-02	Rapporteur's proposal reflecting agreements made at RAN3#27
V.1.0.0	2002-02	Version agreed at RAN3 #27
V.2.0.0	2002-02	Version agreed at RAN3 #27

Rapporteur for 3GPP RAN TR 25.884 is:

Elena Voltolina, Ericsson  
Tel: +46-(0)8-50879417  
Fax: +46-(0)8-4043597  
Elena.Voltolina@era.ericsson.se

This document is written in Microsoft Word version 97 SR-2.