

Presentation of Specification to TSG or WG

Presentation to:	TSG-RAN Meeting #15
Agenda item:	9.10.1 Radio link performance enhancements"
Document for presentation:	TR 25.869 Version 1.0.0 "Tx diversity"
Presented for:	Information

Abstract of document:

This document is the TR 25.869 v1.0.0 based on RAN1 discussion to present RAN#15 meeting for information.

Changes since last presentation to TSG-RAN Meeting #14:

The following sections are included.

Section 1	Scope	
Section 2	References	
Section 3	Definitions, symbols and abbreviations	
Section 4	Background and Introduction	
Section 5	Descriptions of studied concepts	
Section 6	New CPICH Transmission Schemes	
Section 7	Performance	→ No contents
Section 8	Impacts to UE and UTRAN implementation	→ No contents
Section 9	Impacts to physical layer operation	→ No contents
Section 10	Backwards compatibility to R99/R4	
Section 11	Evaluations of the described schemes	→ No contents

Outstanding Issues:

No common agreement in performance results

Contentious Issues:

|

3G TR25.869 V1.0.0(2002-2)

Technical Report



3rd Generation Partnership Project; Technical Specification Group Radio Access Network; Tx diversity solutions for multiple antennas (Release 5)

The present document has been developed within the 3rd Generation Partnership Project (3GPP™) and may be further elaborated for the purposes of 3GPP.

The present document has not been subject to any approval process by the 3GPP Organisational Partners and shall not be implemented. This Specification is provided for future development work within 3GPP only. The Organisational Partners accept no liability for any use of this Specification. Specifications and reports for implementation of the 3GPP™ system should be obtained via the 3GPP Organisational Partners' Publications Offices.

Keywords

<keyword[, keyword]>

3GPP

Postal address

3GPP support office address

650 Route des Lucioles - Sophia Antipolis
Valbonne - FRANCE
Tel.: +33 4 92 94 42 00 Fax: +33 4 93 65 47 16

Internet

<http://www.3gpp.org>

Copyright Notification

No part may be reproduced except as authorized by written permission.
The copyright and the foregoing restriction extend to reproduction in all media.

© 2000, 3GPP Organizational Partners (ARIB, CWTS, ETSI, T1, TTA, TTC).
All rights reserved.

Contents

Foreword.....	5
1 Scope	6
2 References	6
3 Definitions, symbols and abbreviations	7
3.1 Definitions.....	7
3.2 Symbols.....	7
3.3 Abbreviations.....	7
4 Background and Introduction	7
5 Descriptions of studied concepts	8
5.1 Description of the eigenbeamformer concept.....	8
5.1.1 Calculation of the Dominant Eigenvectors	10
5.1.2 Long Term Feedback Scheme	10
5.1.3 Short Term Feedback Scheme	10
5.1.4 Format of Feedback Information.....	11
5.2 Basis selection scheme for > 2 Tx antennas.....	12
5.2.1 Tx antenna weights.....	12
5.2.2 Representation of weight vectors	12
5.2.3 Feedback protocol structure.....	13
5.3 Closed loop mode 1 for > 2 Tx antennas: R2FNTM concept	13
5.4 Tx diversity scheme with beamforming feature.....	14
5.4.1 Description of our solution	14
5.4.2 Example format of feedback information.....	15
5.5 Closed loop transmit diversity mode 2 with reduced states for 4 elements.....	16
5.5.1 Format of Feedback Information.....	17
5.6 Description of the 4-Tx-STTD diversity scheme	17
5.6.1 Channel estimation for the 4-Tx-STTD concept	18
5.6.2 Phase rotation frequency of the 4-Tx-STTD concept.....	19
6 New CPICH Transmission Schemes	19
6.1 New CPICH transmission scheme for > 2 Tx antennas with reduced PAPR and power balancing.....	19
6.1.1 CPICH Transmission Scheme	20
6.1.1.1 CPICH Transmission Scheme	20
6.1.1.2 Receiver Structure of CPICH	21
6.1.1.2.1 Receiver structure of 4-ant diversity UE.....	21
6.1.1.2.2 Receiver structure of 2-ant diversity UE.....	21
6.1.1.2.3 Summary of channel estimation outputs.....	22
6.1.2 Common Physical Channel Tx Scheme	22
6.1.2.1 Common Physical Channel Tx Scheme	22
6.1.2.2 Receiver Structure of Common Physical Channel Tx Scheme	23
6.1.3 Dedicated Physical Channel Tx Scheme	23
6.1.3.1 Dedicated Physical Channel Tx Scheme for R99/R4 UE.....	24
6.1.3.2 Dedicated Physical Channel Transmission Scheme for beyond R99/R4 UE	25
6.2 New pilot scheme for 4-Tx-antennas	25
6.2.1 Description of the proposed pilot transmission scheme	25
6.3 New CPICH Transmission scheme for > 2 Tx antennas.....	27
6.3.1 Definition of new orthogonal pilot sequences	28
6.3.2 Unequal power setting for CPICH.....	28
7 Performance.....	29
8 Impacts to UE and UTRAN implementation	29
9 Impacts to physical layer operation.....	29
10 Backwards compatibility to R99/R4	29
10.1 Eigenbeamformer concept	29
10.2 Basis selection scheme for > 2 Tx antennas.....	29

10.3	New CPICH Transmission scheme for > 2 Tx antennas.....	29
10.4	4-Tx-STTD concept.....	29
10.5	Closed loop mode 1 for > 2 Tx antennas.....	29
11	Evaluations of the described schemes.....	29
	History	30

Foreword

This Technical Specification has been produced by the 3rd Generation Partnership Project (3GPP).

The contents of the present document are subject to continuing work within the TSG and may change following formal TSG approval. Should the TSG modify the contents of the present document, it will be re-released by the TSG with an identifying change of release date and an increase in version number as follows:

Version x.y.z

where:

- x the first digit:
 - 1 presented to TSG for information;
 - 2 presented to TSG for approval;
 - 3 or greater indicates TSG approved document under change control.
- y the second digit is incremented for all changes of substance, i.e. technical enhancements, corrections, updates, etc.
- z the third digit is incremented when editorial only changes have been incorporated in the document.

1 Scope

2 References

The following documents contain provisions which, through reference in this text, constitute provisions of the present document.

- References are either specific (identified by date of publication, edition number, version number, etc.) or non-specific.
- For a specific reference, subsequent revisions do not apply.
- For a non-specific reference, the latest version applies.

[<seq>] <doctype> <#>[([up to and including]{yyyy[-mm]|V<a[b.c]>}[onwards]): "<Title>".

- [1] 3G TS 25.211(V3.5.0): "Physical channels and mapping of transport channels onto physical channels (FDD)".
- [2] 3G TR 25.214 (V3.5.0): "Physical layer procedures (FDD)".
- [3] 3G TS 25.221 (V3.5.0): "Physical channels and mapping of transport channels onto physical channels (TDD)".
- [4] 3G TS 25.224 (V3.5.0): "Physical layer procedures (TDD)".
- [5] Nokia. Recommended simulation parameters for Tx diversity simulations. TSG-R WG1 document, TSGR1#14(00)0867, July 4-7, 2000, Oulu, Finland, 5 pp.
- [6] Siemens. Description of the eigenbeamformer concept (update) and performance evaluation. TSG-R WG 1 document, TSGR1#19(01)0203, February 27 – March 2, 2001, Las Vegas, USA.
- [8] R1-00-0882, "Preliminary version of algorithm and Simulation results for Tx Diversity with more than 2 Tx Antennas," TSG-RAN WG1#14, Oulu, Finland, July 2000
- [9] Nokia, "Backward Compatibility with Tx-Diversity Extensions" 3GPP TSG RAN WG1#19(01)0335, Las Vegas, United States, February 27 – March 2, 2001.
- [10] O. Tirkkonen, A. Boariu and A. Hottinen, "Minimal non-orthogonality rate 1 space-time block code for 3+ Tx antennas", ISSSTA2000, New Jersey, USA, September 2000.
- [11] Nokia, "A simple pilot arrangement for more than two Tx-antennas" TSGR1#20(01)0558, Busan, Korea, May 21-25, 2001.
- [12] Nokia, "Demonstration of a 4-Tx-STTD OL diversity scheme" TSGR1#21(01)0829, Torino, Italy, August 27-31, 2001.
- [13] Siemens, Nokia, "Recommendations on further study on extension of TX Diversity for more than two antennas" TSGR1#20(01)0557, Busan, Korea, May 21-25, 2001.
- [14] 3rd Generation Partnership Project; Technical Specification Group Radio Access Network. Physical Layer Aspects of UTRA High Speed Downlink Packet Access (Release 2000), TR25.848, v. 0.5.0 2000 - 5. In Working Group meeting#18, Boston USA, 15-18, Jan., 2001.
- [15] 3rd Generation Partnership Project; Technical Specification Group Radio Access Network. UE Radio Tx and Rx (FDD) (Release '03), TR25.101, v. 3.3.1 2000 - 6.
- [16] Samsung Electronics Co., Ltd., "New CPICH Transmission scheme for 4-antenna transmit diversity", TSGR1#15(00)1072, TSG-RAN Working Group 1 meeting #15, Berlin, Germany, August 22 - August 25, 2000.

- [17] R1(02)0269, "Text proposal for 4-Tx-pilots (TR25.869)", Espoo, Finland, January 8-11, 2002.
- [18] R1(02)0272, "Text proposal for 4-Tx-pilots (TR25.869)", Orlando, USA, February 18-22, 2002.

3 Definitions, symbols and abbreviations

3.1 Definitions

For the purposes of the present document, the [following] terms and definitions [given in ... and the following] apply.

Definition format

<defined term>: *<definition>*.

example: text used to clarify abstract rules by applying them literally.

3.2 Symbols

For the purposes of the present document, the following symbols apply:

Symbol format

<symbol> <Explanation>

3.3 Abbreviations

For the purposes of the present document, the following abbreviations apply:

Abbreviation format

<ACRONYM> <Explanation>

4 Background and Introduction

The standardization of 3rd generation WCDMA system has been going on in 3rd Generation Partnership Project (3GPP) since the end of 1998. The 3G systems bring a promise of much higher data rates and enhanced services when compared to 2G systems. As many of the proposed services, like wireless web browsing, are expected to be downlink-intensive it was recognized from the very beginning that improvement of downlink capacity is one of the main challenges.

Performance of radio system depends on various issues but one important factor is the available diversity (time, frequency, multipath etc.). Due to wide bandwidth WCDMA systems are especially effective in exploiting the multipath diversity existing in time dispersive radio environments. If little or no multipath diversity is available the performance can degrade quite considerably. One way of improving the situation is to utilize 2 or more receive and/or transmit antennas that effectively speaking introduce additional radio paths and thereby increase the available diversity. As receiver antenna diversity is implementation wise challenging especially for low cost terminals a lot of attention have been paid to various transmit diversity solutions to be employed on radio access network side.

During 1999 a great deal of effort was put on defining transmit diversity solutions for Rel.-99 of 3GPP WCDMA specifications. As a result two open loop techniques, Space Time Transmit Diversity (STTD) and Time Switched Transmit Diversity (TSTD), and closed loop solution based on Transmit Adaptive Array (Tx AA) concept with two different modes were standardized for FDD [1,2]. For TDD, TSTD and Block STTD open loop methods can be used on SCH and P-CCPCH, respectively, and closed loop methods on DPCH [3, 4]. All the Rel.-99 Tx diversity methods assume two transmit antennas.

Already during 1999 it was recognized that further performance improvements could be possible by increasing the number of transmit antennas. Yet, it was agreed that Tx diversity for more than 2 antennas will be studied for possible inclusion to Rel.-5 of 3GPP specifications. The following chapters describe the proposed concepts, present the

performance results, consider the impacts on UE and UTRAN implementation, and physical layer operation, and, finally, present issues related to backwards compatibility to Rel.-99 followed by conclusions.

Note, that the schemes included in this TR are currently for the purpose of description of new schemes only.

5 Descriptions of studied concepts

5.1 Description of the eigenbeamformer concept

With increasing the number of antenna elements by using an extension of the Release-99 TxD modes, the amount of necessary feedback is increased. When keeping the uplink bandwidth the same the antenna weights cannot be adjusted fast enough to account for fast fading. Hence, for higher velocities of the UE the gain due to the additional antenna elements is low.

However there are ways to reduce the necessary feedback bandwidth if the antenna channel paths are correlated. One possible concept to achieve a lower feedback bandwidth is the eigenbeamformer concept which takes advantage of the correlated antenna paths. The general idea behind the eigenbeamformer is a decorrelation of the antenna signal paths to achieve a reduction in dimension of the spatial space. This enables subsequent short term processing at the UE to sufficiently mitigate fast fading.

This decorrelation is performed by exploiting the long term properties of the propagation paths based on an eigenanalysis of its long term spatial covariance matrix. The eigenvectors (in the sequel also called eigenbeams) with the largest eigenvalues (largest average UE receive power) are determined and fed back step by step to the Node B. This process takes place on the same time scale as the physical UE movement. Accordingly, the required operations in the UE as well as required feedback bits are distributed over a very large number of slots.

In addition, a short term selection between the eigenbeams is carried out at the UE to account for fast fading. This information is fed back to the Node B on (almost) every slot.

By this technique it is possible to address a larger number of antenna elements providing large beamforming gains at higher velocities.

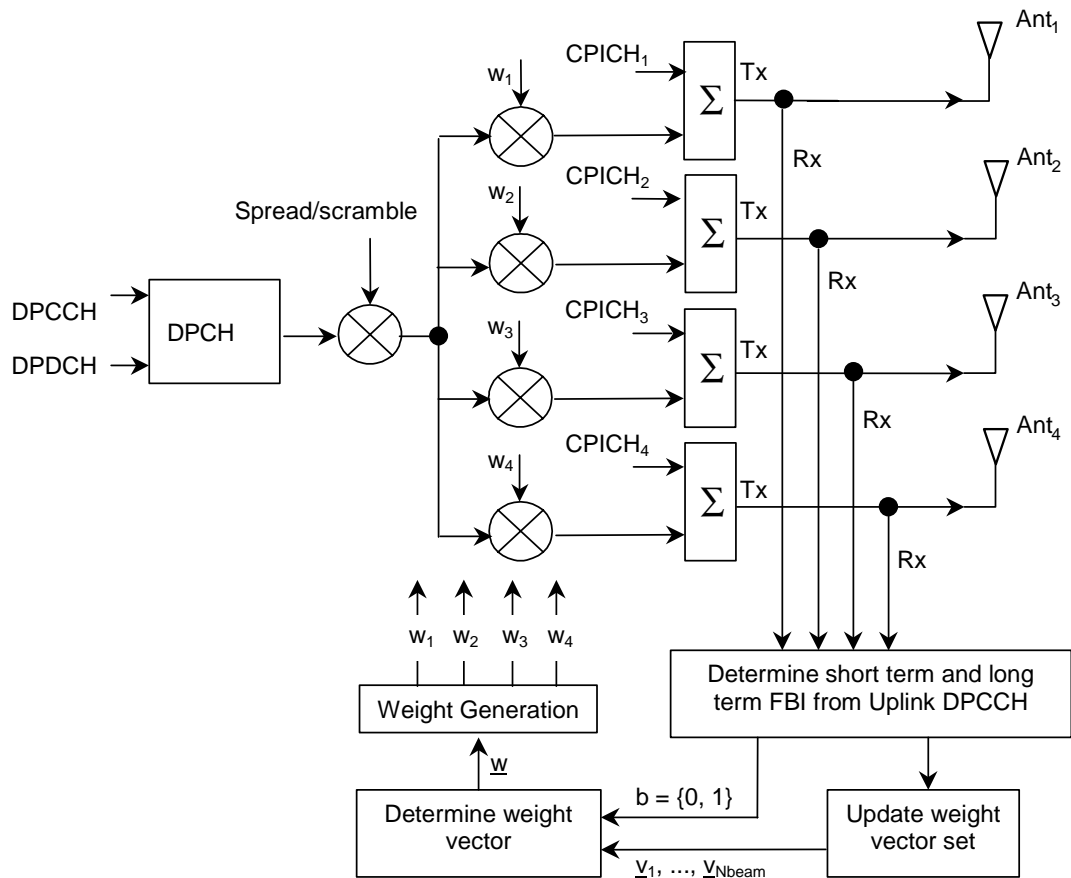

Figure 1. Generic Downlink transmitter at the Node B with $M = 4$ antenna elements

Figure 1 and Figure 2 show the generic architecture of the eigenbeamformer concept at the Node B and the UE. In the following sections the focus is on a system with $M = 4$ antenna elements and $N_{\text{beam}} = 2$ or 4 eigenvectors. However the eigenbeamformer is easily extendable to more antenna elements.

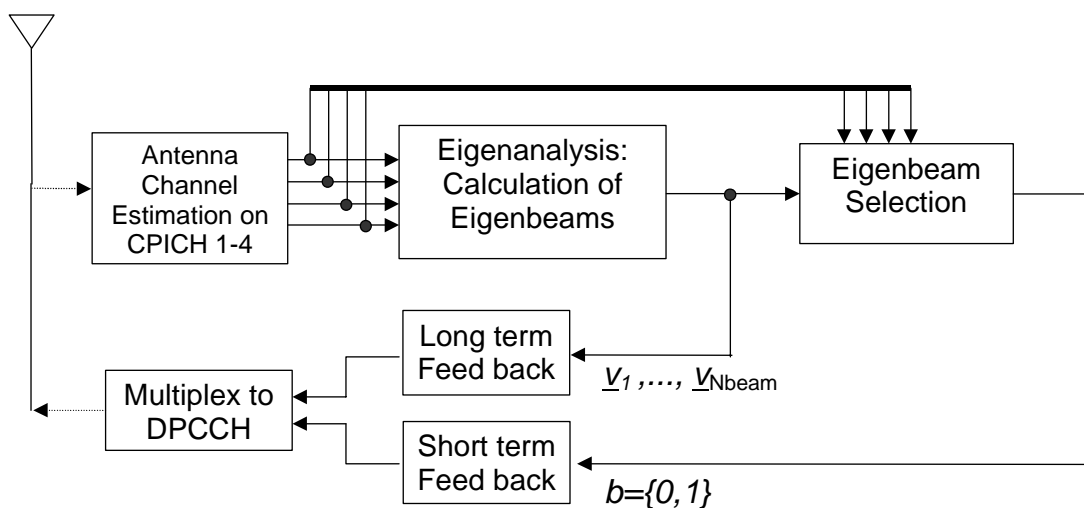

Figure 2. Generic eigenbeamformer structure at the UE for $M = 4$

5.1.1 Calculation of the Dominant Eigenvectors

Using orthogonal pilot sequences transmitted from the Node B antenna elements, the UE estimates the short term spatial covariance matrix averaged over the temporal taps of the channel.

$$\mathbf{R}_{ST} = \sum_{n=1}^N \mathbf{h}_n \mathbf{h}_n^H \quad (1)$$

The column vector $\mathbf{h}_n = (h_{n1}, h_{n2}, \dots, h_{nM})^T$ denotes the channel vector of the n-th temporal tap. The number of taps is denoted by N; M = 4 antenna elements are assumed. The long term spatial covariance matrix is obtained by averaging the short term matrix using a forgetting factor ρ .

$$\mathbf{R}_{LT}(i) = \rho \mathbf{R}_{LT}(i-1) + (1-\rho) \mathbf{R}_{ST}(i) \quad (2)$$

The symbol i denotes the time index. It is sufficient to perform an update once every frame or even in larger intervals.

Decorrelation in space is achieved by an eigenanalysis of the long term spatial covariance matrix according to

$$\mathbf{R}_{LT} \mathbf{V} = \mathbf{V} \mathbf{\Theta} \quad (3)$$

The eigenvectors (eigenbeams) to be found are columns of \mathbf{V} . Since the matrix $\mathbf{\Theta}$ is diagonal by definition, transmission on different eigenbeams leads to uncorrelated fast fading. The diagonal entries indicate the long term UE received power of each beam.

Note that the eigenbeamformer automatically adjusts to various propagation environments (spatially correlated or uncorrelated). If the channel is spatially correlated, the channel can accurately be described by a small number of eigenbeams. If, on the other hand, the channel has a spatial correlation of zero, no long term spatial channel information can be exploited and each eigenvector addresses only one antenna element.

5.1.2 Long Term Feedback Scheme

From the set of M = 4 eigenbeams in \mathbf{V} , Nbeam vectors with the largest eigenvalues will be chosen to be transmitted in the long term feedback.

Each weight vector is a vector of complex numbers. The size of this vector equals the number of antenna elements (M = 4). Each complex vector element is quantized by a number of bits. There are different ways for quantization. For example, the absolute value and the phase can be quantized with 3 and 5 bits respectively. Hereby, the amount of bits can be reduced if the phase of the first vector element is set to zero. Thus, for the transmission of one eigenbeam $4*3+3*5 = 27$ bits are necessary.

This number applies for the direct feedback of the eigenbeams from the UE to the Node B. Also methods with progressive refinement could be used that transmit only the difference to the previously sent vector. This could reduce the subsequent update period and an increased quantization / resolution is possible.

More advanced long term feedback concepts could be used which require less feedback bits.

To ensure good performance of the eigenbeamformer concept it is essential to add redundancy to the long term feedback. Therefore coding is used to be capable of detecting and correcting feedback errors. There are several possibilities to define such a code. One possibility described here is a simple BCH code with code rate of 54/110. For two coded eigenbeams a total of 110 bits are transmitted. The number of bits per eigenbeam roughly doubles and so the code is capable to detect and correct 9 bit errors. In the unlikely event of more than 9 bit errors in one coding block it can be assumed that the Node B detects this incorrect feedback by making a plausibility check, e.g. checking the orthogonality of the eigenbeams. In that case the previously used eigenbeams could be reused once more.

5.1.3 Short Term Feedback Scheme

Scheme 1: Eigenbeamformer using selection

A short term estimate of the UE received power is performed for each eigenbeam by calculating

$$P_m = \mathbf{v}_m^H \mathbf{R}_{ST}^T \mathbf{v}_m = \sum_{n=1}^N \left| \mathbf{v}_m^T \mathbf{h}_n \right|^2 \quad (4)$$

where m characterizes the eigenbeam. The eigenbeam that results in the maximum value for the received power Pm is selected and signalled to the Node B.

For two (four) eigenbeams 1 (2) bit(s) is (are) transmitted to indicate the selection.

The overlaying long term processing makes it possible to switch between eigenbeams instead of antenna elements. An increasing number of antenna elements can be addressed without reducing the UE velocity threshold.

Note that the pilot symbols of the DPCCCH may be used for eigenbeam verification similar to the closed loop modes in Release-99.

Scheme 2: Eigenbeamformer using weighted combining

A short term estimate of the UE received power is performed for each weight vector by calculating

$$P_m = \mathbf{w}_m^H \mathbf{R}_{ST}^T \mathbf{w}_m = \sum_{n=1}^N \left| \mathbf{w}_m^T \mathbf{h}_n \right|^2 \quad (5)$$

where $\mathbf{w}_m = \mathbf{v}_1 + \left(\sqrt{\lambda_2} / \sqrt{\lambda_1} \right) \mathbf{v}_2 \exp(j\theta_m)$, $\theta_m \in \{ \pi/4 \quad 3\pi/4 \quad -3\pi/4 \quad -\pi/4 \}$. m characterizes the degree of the combining phase. Where λ_1 and λ_2 is first and second largest eigenvalue of long term covariance matrix, \mathbf{R}_{LT} , respectably and θ_m is a short term parameter. The weight vector that results in the maximum value for the received power Pm is selected and signalled to the Node B.

For two (four) eigenbeams 2 (4) bits are transmitted to indicate the selection and progressive refine is applied to transmit each bit. The overlaying long term processing makes it possible to co-phase combine two(four) eigenbeams instead of antenna elements.

An increasing number of antenna elements can be addressed without reducing the UE velocity threshold. Note that the pilot symbols of the DPCCCH may be used for eigenbeam verification similar to the closed loop modes in Release-99.

5.1.4 Format of Feedback Information

The feedback rate for the eigenbeamformer is kept at the same rate as in Release-99 and is 1500 bit/s. The long term information bits (for feedback of eigenbeams) and the short term information bits (for feedback of eigenbeam selection) are multiplexed. The following frame format for the feedback information bits is proposed:

Table 1: Multiplexing of long term / short term feedback information

Slot #	1	2	3	4	5	6	7	8	9	10	11	12	13	14	15
short term FB bits	1	1	1	1	1	1	1	1	1	1	1	1	1	1	0
long term FB bits	0	0	0	0	0	0	0	0	0	0	0	0	0	0	1

In this multiplexing format the transmission of two eigenbeams would take $2 \cdot 27 = 54$ frames or 540 ms (see section 5.1.2). The eigenbeam selection of the previous slot is applied in the slots where no short term feedback information is received by the Node B (slot #15).

This format is confined to one radio frame. Thus, no counting over frame boundaries is necessary.

In a later extension with more than 4 antenna elements other formats could be used, e.g. using 3 long term feedback bits within one frame. This is for further study.

Table 2: Multiplexing format of long term / short term information for more than 4 antenna elements

Slot #	1	2	3	4	5	6	7	8	9	10	11	12	13	14	15
short term FB bits	1	1	1	1	0	1	1	1	1	0	1	1	1	1	0
long term FB bits	0	0	0	0	1	0	0	0	0	1	0	0	0	0	1

Since no long term channel information is available at the Node B for a user at the start of transmission, initial weight vectors may, for instance, address only one of the antenna elements, e.g.,

$$\mathbf{v}_1 = \begin{pmatrix} 1 \\ 0 \\ 0 \\ 0 \end{pmatrix}, \quad \mathbf{v}_2 = \begin{pmatrix} 0 \\ 1 \\ 0 \\ 0 \end{pmatrix} \quad \text{for } M = 4 \text{ antenna elements.}$$

5.2 Basis selection scheme for > 2 Tx antennas

5.2.1 Tx antenna weights

In closed loop Tx diversity systems, the weights of transmit antennas are determined at a mobile station and fed back to the base station. These weights should result in as high SNR as possible at the mobile. The set of these weights may be viewed as a vector $\underline{w} = [w_1 \ w_2 \ \dots \ w_i \ \dots \ w_M]^T$, where w_i is a complex weight associated with the i th Tx antenna. For the maximum SNR at the mobile, the weights should maximize P below:

$$P = \underline{w}^H H^H H \underline{w}, \quad (5)$$

when $H = [h_1 \ h_2 \ \dots \ h_i \ \dots \ h_M]$ and M is the number of Tx antennas. The column vector h_i represents an estimated channel impulse response for the i th Tx antenna, and its vector length equals to the number of paths. The weight vector \underline{w} information is periodically fed back to the base station. Note that the amount of feedback information and the implementation complexity increase with the number of Tx antennas. The efficient representation of a weight vector is desired to reduce the amount of feedback data and the implementation complexity. Furthermore, backward compatibility is desirable.

A weight vector with M elements may be represented as a linear sum of basis vectors, which span an M -dimensional space. Examples of basis vectors for 2-, 3-, 4-dimensional spaces are shown in Appendix A of [8]. Let's assume for explanation that 4 Tx antennas are used for Tx diversity. The optimal weight vector \underline{w}_{opt} for this system has 4 elements and may be represented as a linear sum of four basis vectors, $\underline{B}_1, \underline{B}_2, \underline{B}_3, \underline{B}_4$, as follows:

$$\underline{w}_{opt} = c_1 \underline{B}_1 + c_2 \underline{B}_2 + c_3 \underline{B}_3 + c_4 \underline{B}_4 \quad (6)$$

where c_1, \dots, c_4 are complex coefficients associated with corresponding vectors. Assuming that $|c_1| > |c_2| > |c_3| > |c_4|$, \underline{w}_{opt} may be approximated as

$$\underline{w}_{app_1} \cong c_1 \underline{B}_1, \quad (7.a)$$

$$\underline{w}_{app_2} \cong c_1 \underline{B}_1 + c_2 \underline{B}_2, \quad (7.b)$$

$$\underline{w}_{app_3} \cong c_1 \underline{B}_1 + c_2 \underline{B}_2 + c_3 \underline{B}_3, \quad (7.c)$$

These vectors $\underline{w}_{app_1}, \underline{w}_{app_2}, \underline{w}_{app_3}$, may be viewed as the projections of \underline{w}_{opt} into 1-dim, 2-dim, and 3-dim subspaces. \underline{w}_{app_3} is more accurate representation of \underline{w}_{opt} than \underline{w}_{app_1} and \underline{w}_{app_2} .

5.2.2 Representation of weight vectors

The conventional representation of the vector \underline{w}_{opt} may require $(M-1) * N_c$ bits, where N_c bits are required to represent each element of \underline{w}_{opt} . This representation indicates that the transmission of $(M-1) * N_c$ bits at 1500Hz is required to support Tx diversity with M Tx antennas. The reason for $(M-1) * N_c$ not $M * N_c$ is that one of M Tx antennas may be viewed as reference and the relative weights for other antennas are required. To reduce the required number of bits, it is proposed to feedback information on the approximated vector, instead of \underline{w}_{opt} . The representation of the approximated

vector includes the specification of basis vectors and associated coefficients. When there are M Tx antennas and the approximation is made in a S -dimensional subspace, there are ${}_M C_S$ combinations for selecting S basis vectors among M vectors and the required number of bit to specify the basis vector combination is $\lceil \log_2 ({}_M C_S) \rceil$.

5.2.3 Feedback protocol structure

In the simulation, the two cases for antenna selection is considered: **Case 1**) 2 antenna selection ($M=4, S=2$), it noted as 4C2 and **Case 2**) 3 antenna selection ($M=4, S=3$), it noted as 4C3. In both cases, 2bit representation for each element (phase only) is used ($N_c = 2$). The required number of feedback information per signalling word is: **Case 1**) 5 bits, and **Case 2**) 6bits. For detail simulation scheme, section 6.2.1 can be referred. The considered frame format of feedback information is:

(Case 1: 2 best selection among 4 basis and combine all 2 with received phase information)

Slot	1	2	3	4	5	6	7	8	9	10	11	12	13	14	15
Phase				P_1	P_2				P_1	P_2				P_1	P_2
Selection	S_1	S_2	S_3			S_1	S_2	S_3			S_1	S_2	S_3		

S_i : Antenna selection bits

P_i : Phase difference with respect to the coefficient associated with the first basis vector

(Case 2 : 3 best selection among 4 basis and combine all 3 with received phase information)

Slot	1	2	3	4	5	6	7	8	9	10	11	12	13	14	15
Phase			P_{11}	P_{12}	P_{21}	P_{22}			P_{11}	P_{12}	P_{21}	P_{22}			P_{11}
Selection	S_1	S_2					S_1	S_2					S_1	S_2	

S_i : Antenna selection bits

P_{ij} : Phase difference with respect to the coefficient associated with the first basis vector

5.3 Closed loop mode 1 for > 2 Tx antennas: R2FNTM concept

As pointed in [6], there are much of issues that may/will degrade the “optimal” CL 4-Tx-diversity results, and in order to go forward with CL concepts, much of further analysis is needed. This section contains only a basic description (and basic results in 6.2) not trying to give the full analysis.

In the Rel.-99 closed loop mode 1 UE calculates the phase adjustment to be done at the UTRAN access point. This involves the calculation of the phase difference between the signals transmitted from the two antennas. When there are N Tx-antennas, a straight forward extension of the mode 1 is to calculate the needed phase adjustment for each $N-1$ antennas with respect to the reference antenna and signal those adjustments back to the UTRAN. How fast this information can be communicated to UTRAN depends naturally on the number of antennas and the feedback bit rate. This in turn will determine the sensitivity of the performance to the UE speed, i.e. the performance will deteriorate faster as a function of UE speed if the feedback bit rate is low and N large. As it is not desirable to increase the feedback bit rate from 1500 bps as defined in Rel.-99 methods trying to enhance the performance given the restrictions in feedback signaling need to be studied.

In Rel.-99 closed loop mode 1 the filtering of the phase adjustments at the UTRAN access point is specified as simple (sliding window) averaging over two consecutive values. This could be denoted as R2F2T2 where R2 denotes the number of constellation sets due to rotation, F2 denotes the filter of length 2 and T2 denotes the 2 T_x antennas. This can be generalized to R2FNTM, that is rotation constellation set per antenna remains the same as in Rel.-99, length of the phase adjustment filter is N , and there are M Tx-antennas.

In order to maintain the same rate of feedback as in the Rel.-99 mode 1, the weight of only one antenna is fed back in one slot. Hence, the actual memory of the filter is $(M-1)(N-1)$ slots. In case of 4 Tx-antennas ($M=4$), let Z_1, Z_2, Z_3 be the feedback for antennas 2,3,4 respectively, with antenna 1 being the reference antenna. Let $N = 4$ (R2F4T4). It is clear that in this example case the current antenna weight relies on feedback weights sent 9 slots in the past as illustrated in the Figure 1.

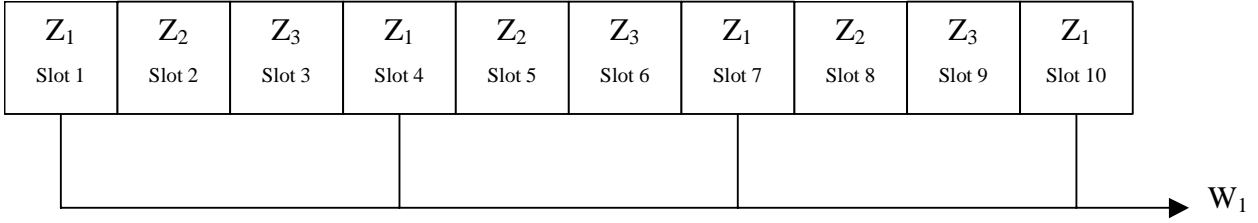

Figure 3. Filtering of the feedback commands

The filter itself could be of various types but a simple solution is to use the same averaging equation as in the Rel.-99 mode 1. End of frame adjustments can also be made as in the case of Rel. -99 mode 1. Some of the combinations fed to the filter lead to a filtered output of zero. In those cases, either the previously used antenna weight can be reused, or the next closest weight constellation point can be used.

5.4 Tx diversity scheme with beamforming feature

It is desirable that the closed loop multiple antenna transmit diversity/beamforming scheme can support a variety of antenna configurations and beamforming algorithms. To achieve it efficiently, the higher layer signaling information about Tx antenna configurations of Node B to UE is necessary. As the spatial correlation largely depends on the Tx antenna configurations in most cases, it will greatly help UEs to determine how appropriately the diversity and beamforming be combined, e.g. the number of beams and the feedback frame format.

Spatial correlation property depends on both the transmit antenna configuration and the radio propagation environment. The latter is unpredictable and performance depends on how feedback scheme matches the channel. For example, in strong spatially correlated channels, frequent update of short-term diversity weights is not efficient. In spatially uncorrelated channels, feedback bits for long-term beamforming weights are useless. The former, selection of antenna configuration, is one of the design criteria for cellular operators. It is rather easy to control spatial correlation by choosing appropriate antenna configuration.

In theory, employing multiple transmit antenna elements can achieve both diversity gain and beamforming gain. If the antennas are placed far away from each other, maximum diversity gain can be achieved but, due to the grating lobe problem, the achievable beamforming gain is limited. On the other hand, if the inter-element spacing in the antenna array is small, maximum beamforming gain can be obtained but the diversity gain will be limited as signals from different antenna elements are highly correlated.

5.4.1 Description of our solution

According to the transmit antenna configuration of the Node B, UE calculate short-term diversity weights and long-term beamforming weights. The hierarchical weighting is defined as shown in Figure 4.

Consider an M sub-arrays configuration in which each sub-array consists of $K=N/M$ elements. Firstly, UE finds an M -dimensional short-term diversity weight vector \underline{w}_D , which maximize

$$P_D = \underline{w}_D^H H_D^H H_D \underline{w}_D \quad (1)$$

$$\text{with } H_D = [\underline{h}_1, \underline{h}_{K+1}, \dots, \underline{h}_{(M-1)K+1}]$$

where, $\underline{h}_{(m-1)K+1}$ ($m = 1 \dots M$) is the channel response vector, which represents the m -th sub-array.

Secondly, UE finds a K -dimensional beamforming weight vector $\underline{w}_{B,m}$ for each sub-array which maximize

$$P_{B,m} = \underline{w}_{B,m}^H \mathbf{H}_{B,m}^H \mathbf{H}_{B,m} \underline{w}_{B,m} \quad (2)$$

$$\text{with } \mathbf{H}_{B,m} = [\underline{h}_{(m-1)K+1}, \underline{h}_{(m-1)K+2}, \dots, \underline{h}_{(m-1)K+K}]$$

where, $\underline{h}_{(m-1)K+k}$ ($k = 1 \dots K$) is the channel response vector of the k -th element in the m -th sub-array.

Then, short-term diversity weights $D_{1,m}$ and long-term beamforming weights $B_{m,k}$ for the hierarchical weighting are calculated from \underline{w}_D and $\underline{w}_{B,m}$ as follows.

$$D_{1,m} = \frac{w_D(m)}{w_D(1)} \quad (m = 1 \dots M) \quad (3)$$

$$B_{m,k} = \frac{w_{B,m}(k)}{w_{B,m}(1)} \quad (m = 1 \dots M, k = 1 \dots K) \quad (4)$$

$\{D_{1,m}\}$ corresponds to the M -branch Tx diversity weights and $\{B_{m,k}\}$ are beamformer weights for the m -th antenna group. The feedback frequency for $\{D_{1,m}\}$ is much higher than that for $\{B_{m,k}\}$ to suit for fast fading environment.

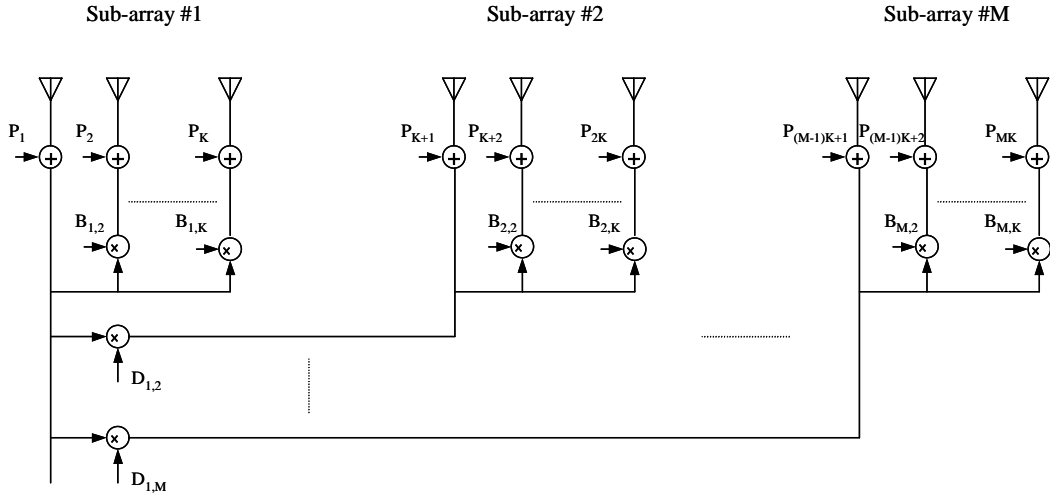

Figure 4. Hierarchical weighting for the transmit antenna diversity/beamforming

5.4.2 Example format of feedback information

The following frame formats for the feedback information bits are desirable. Format 1 is for Tx diversity and it allows employing the scheme without beamforming features. Format 2 is for beamforming with small inter-element spacing less than spatial correlation length. All of 15 bits/frame for beamformer weights can be used for accurate control of the beam. Format 3 is for combination of diversity and beamforming, which is suitable for the sub-array antenna configuration. Single beamformer weight is quantized by 3 bits and fed back in a frame to Node B. In case of two-sub-array system, the beamformer weight of sub-array #1 is transmitted in the first frame, then the beamformer weight of sub-array #2 is transmitted in the second frame. The number of antenna elements in each sub-array can be increased, as long as the feedback delay is permissible for updating the beamformer weights.

Table 3. Multiplexing format 1 of feedback information for Tx diversity

Slot #	1	2	3	4	5	6	7	8	9	10	11	12	13	14	15
FB bits for D	1	1	1	1	1	1	1	1	1	1	1	1	1	1	1
FB bits for B	0	0	0	0	0	0	0	0	0	0	0	0	0	0	0

Table 4. Multiplexing format 2 of feedback information for beamforming

Slot #	1	2	3	4	5	6	7	8	9	10	11	12	13	14	15
FB bits for D	0	0	0	0	0	0	0	0	0	0	0	0	0	0	0
FB bits for B	1	1	1	1	1	1	1	1	1	1	1	1	1	1	1

Table 5. Multiplexing format 3 of feedback information for combination of diversity and beamforming

Slot #	1	2	3	4	5	6	7	8	9	10	11	12	13	14	15
FB bits for D	1	1	1	1	0	1	1	1	1	0	1	1	1	1	0
FB bits for B	0	0	0	0	1	0	0	0	0	1	0	0	0	0	1

5.5 Closed loop transmit diversity mode 2 with reduced states for 4 elements

Similar to Rel-99 closed loop Tx diversity systems, the weights of transmit antennas are determined at a mobile station and fed back to the base station. The set of weights at the UTRAN-AP $\underline{w} = [w_1 \ w_2 \ \dots \ w_i \ \dots \ w_M]^T$, where w_i is a complex weight associated with the i th Tx antenna are chosen to maximize P below:

$$P = \underline{w}^H H^H H \underline{w}, \quad (5)$$

where $H = [h_1 \ h_2 \ \dots \ h_i \ \dots \ h_M]$ and M is the number of Tx antennas. The column vector h_i represents an estimated channel impulse response for the i th Tx antenna, and its vector length equals to the number of paths.

Two extensions of the Rel'99 closed loop transmit diversity mode 2 for the case of 4 elements are considered with 4 phases and 8 phases states per element as defined in Table x1 and Table x2 respectively.

Table x1. FSM of modified closed loop mode 2 (4p0g) signalling message per element

FSM	Phase difference between antennas
00	$\pi/4$
01	$3\pi/4$
11	$-3\pi/4$
10	$-\pi/4$

Table x2. FSM of modified closed loop mode 2 (8p0g) signalling message per element

FSM	Phase difference between antennas
000	0
001	$\pi/4$
010	$3\pi/4$
011	$\pi/2$
100	$-\pi/4$
101	$-\pi/2$
110	π
111	$-3\pi/4$

Therefore 6 bits and 9 bits feedback per slot are needed for the update of the antenna coefficients for 4p0g and 8p0g respectively. If we consider **1 bit feedback per slot**, Progressive refinement (as described for Rel 99 Closed loop transmit diversity Mode 2) is used to update the antenna coefficients.

5.5.1 Format of Feedback Information

The uplink feedback information signalling is similar to the Rel-99 mode 2, that is using progressive refinement both at the UE and UTRAN-AP. The only change is the number of states, at the UE, to be compared for maximising $P = \underline{w}^H H^H H \underline{w}$, is increased due to 4 elements instead of 2 (Rel 99). The FSM (Tables x1 and x2) corresponding to coefficient of the antenna 2, 3 and 4 are sent successively.

5.6 Description of the 4-Tx-STTD diversity scheme

Starting point in the design of the proposed 4-Tx-STTD has been an observation that open loop (OL) schemas perform much better at high velocities than at stable channels since of better interleaving caused by velocity. Complexity increase is also required to be minimize compared to 2-Tx-STTD, as well as full compatibility with rel'99 structures (e.g. interleavers).

4-tx-STTD utilizes Alamouti's space-time block code: encoding by 4-Tx-STTD means to transmit the first STTD diversity branch (s_1, s_2, \dots) via the first and the phase rotated replica via the second antenna. The second STTD diversity branch is transmitted in an analog manner from the antennas 3 and 4.

The general encoding scheme for 4-tx-STTD is presented in the figure 4.

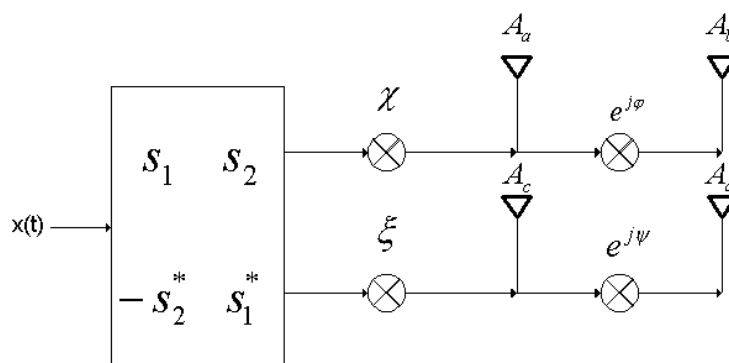

Figure 4. Encoding for 4-Tx-STTD.

Pseudo-antennas can be defined e.g. as $A_a := A_1 + A_2$, $A_b := A_3 + A_4$, $A_c := A_1 - A_2$ and $A_d := A_3 - A_4$ if power balancing is required.

Phase hopping by using 8-level quantization gives the required performance. The rotation phases are picked from a short look-up-table, keeping the same phases over the period of at least 2 symbols.

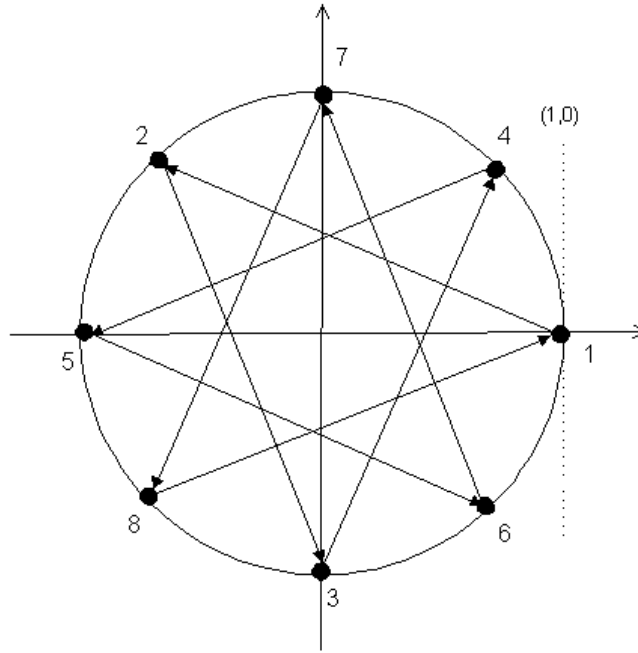

Figure 5 One optimal configuration of phase offsets

One optimal configuration is obtained when the periodic phase shift pattern of shifts in degrees of $\{0, 135, 270, 45, 180, 315, 90, 225\}$ on pseudo antenna 2 and respectively $\{180, 315, 90, 225, 0, 135, 270, 45\}$ on pseudo antenna 4 is applied.

It is required that $\varphi = \psi + \pi$, and therefore it is sufficient to have only one look-up table for the both phase rotated channels.

Decoding procedure for 4-Tx-STTD is similar to that of 2-Tx-STTD except that in the decoding of the STTD-branches estimates of rotated channels

$$\begin{cases} h_1 + \exp(j\varphi)h_2 \\ h_3 + \exp(j\psi)h_4 \end{cases} \quad (2)$$

are used, where h_i is the channel estimation of the i 'th physical antenna. Gain factors χ and ξ are adjusted depending on channel estimation quality.

5.6.1 Channel estimation for the 4-Tx-STTD concept

Depending on the CpiCH transmission scheme used we distinguish two different cases how the channel estimation for 4-tx-STTD can be done.

Channel estimation for symmetric pilots:

In this case the common pilot power is evenly distributed between primary and secondary CPiCH, and all the four channels are estimated from common pilots (i.e., from P-CpiCH and S-CpiCH). In this case $\chi = \xi = 1$.

Channel estimation for non-symmetric pilots:

Non-symmetric channel estimation approach is used in the case that rel'99 backward compatibility reasons force us to avoid the use of S-CpiCH or it's power is at remarkably lower level than that of P-CpiCH. In this case the first STTD branch transmitting non-transformed signal is estimated from P-CpiCH and the additional channels transmitting the transformed signal are estimated from the dedicated pilots. This is illustrated in the figure 5. In order to improve the quality of the dedicated channel estimates of the additional channels additional pilot power offset may be used. If we

are forced to use non-symmetric channel estimation, then from the performance point of view it is beneficial to set $\chi > \xi$.

The non-symmetric pilot arrangement minimizes the effect of channel estimation errors and guarantees that 4-tx-STTD always outperforms one antenna transmission ($\xi = 0$). The scheme is also well power balanced.

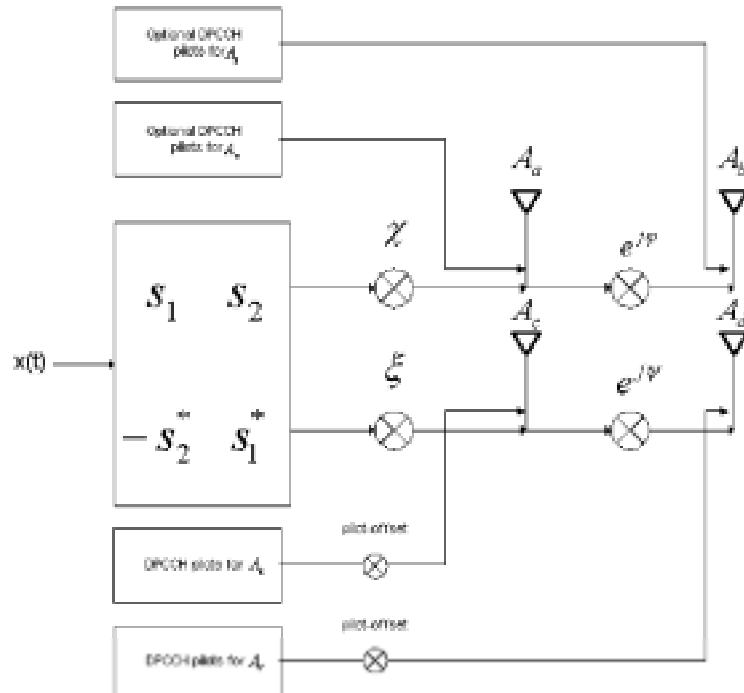

Figure 5. Using dedicated pilots for channel estimation of the second diversity branch.

5.6.2 Phase rotation frequency of the 4-Tx-STTD concept

One issue that should be considered when the 4-Tx-STTD is used is the phase rotation frequency. Two different options exist. First option is to use fixed phase rotation frequency *in time* meaning that the rotation phases are updated once in a certain time period. Another option is to use fixed phase rotation frequency *in symbols* meaning that a certain number of consecutive 4-Tx-STTD encoded data symbols in phase rotated channels are rotated by using the same rotating phase.

6 New CPICH Transmission Schemes

6.1 New CPICH transmission scheme for > 2 Tx antennas with reduced PAPR and power balancing

In Release 99 specification, transmit diversity using 2 antennas is included. Currently, various transmit diversity schemes using 4 transmit antenna are considered for possible extension to Release 2000. However, the most important thing that should be solved first is the pilot reference channel for 4-antenna.

In this document, a new CPICH transmission scheme is proposed for 4-antenna transmit diversity. The most important thing that should be kept in mind when proposing new CPICH transmission scheme for 4-antenna transmit diversity is the backward compatibility. Here, the backward compatibility means that the Release 99 UE should be able to demodulate the whole physical channels (dedicated or common physical channel) without any change in receiver structure.

In section 6.1.1, the transmission scheme of CPICH for 4-antenna transmit diversity is described and the backward compatibility is proved. In section 6.1.2, corresponding common physical channel transmission scheme with 4 transmit antenna to satisfy the backward compatibility is proposed. And the corresponding transmission schemes of dedicated physical channel with 2-antenna and 4-antenna transmit diversity UE are described in section 6.1.3.

Let's distinguish UEs by their diversity mode as following.

- 2-ant diversity UE: UE in 2-antenna diversity mode (open/closed)
- 4-ant diversity UE: UE in 4-antenna diversity mode (open?/closed?)

6.1.1 CPICH Transmission Scheme

6.1.1.1 CPICH Transmission Scheme

If UTRAN supports 4 transmit diversity (open or closed loop) for dedicated channel to UE in the cell, then it should provide 3 additional diversity pilot channels as well as primary CPICH. However, since the CPICH is a common physical channel it also should be received by all UEs with different diversity mode, and thus one and only one CPICH transmission scheme should be used. Each UE should estimate the channel(s) as many as the number of transmit antenna, since each antenna has its own path. That is, common CPICH transmission scheme for 4 transmit antenna shall have the property that it must be recognised as one, two, or 4 pilot channels to 2-ant diversity UE and 4-ant diversity UE, respectively. Figure 3 shows the proposed CPICH transmission scheme for 4 transmit antenna which satisfies the property. The main characteristics of the proposed CPICH transmission scheme are:

- using two OVSF codes (C_{OVSF1} and C_{OVSF2})
- same pilot pattern as Release 99' 2-ant CPICH (AA and A-A/ -AA)
- different control of pilot channel gain for 2-ant or 4-ant diversity reception
- backward compatible with Release 99
- reduce PAPR by distributing physical channels to 4 antenna

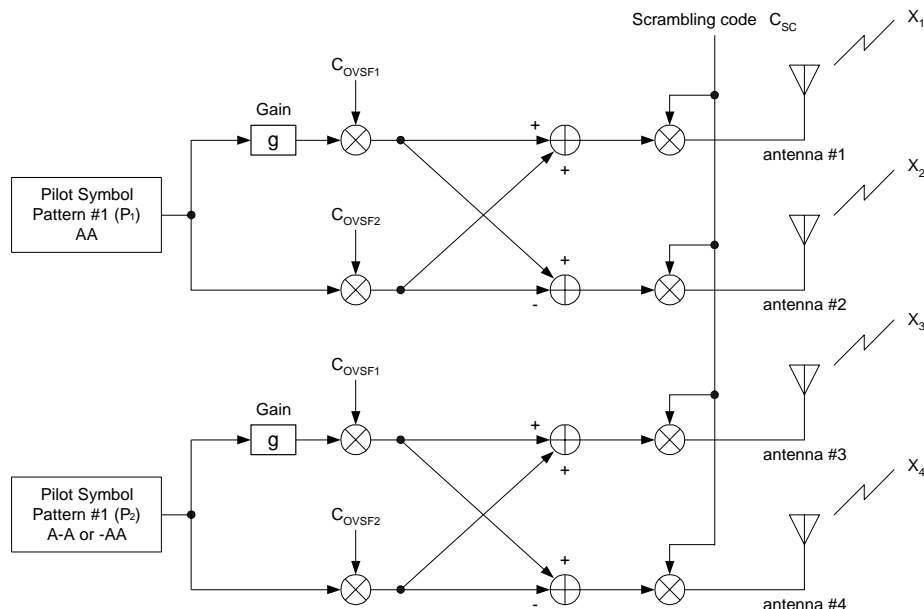

Figure 6. Proposed CPICH transmission scheme for 4 antenna transmit diversity

The CPICH signal from each antenna at the receiver side is given by the following equations. The timing index and background noise is ignored for simplicity.

$$\begin{aligned}
X_1 &= P_1 \times (g \cdot C_{OVSF1} + C_{OVSF2}) \times C_{SC} \times h_1 \\
X_2 &= P_1 \times (g \cdot C_{OVSF1} - C_{OVSF2}) \times C_{SC} \times h_2 \\
X_3 &= P_2 \times (g \cdot C_{OVSF1} + C_{OVSF2}) \times C_{SC} \times h_3 \\
X_4 &= P_2 \times (g \cdot C_{OVSF1} - C_{OVSF2}) \times C_{SC} \times h_4
\end{aligned} \tag{8}$$

where P_1 (=AA) and P_2 (=A-A or -AA) are the two pilot patterns defined for 2-ant CPICH in Release 99, and C_{SC} is the primary scrambling code. In Eq. ([8]), C_{OVSF1} and C_{OVSF2} are two OVSF codes where C_{OVSF1} is $C_{ch,256,0}$ and C_{OVSF2} is one additional OVSF code. h_1, h_2, h_3, h_4 are the channel coefficients for each antenna path. It is worth noting that the parameter g in Eq. ([8]) is the gain factor to discriminate the received pilot power for 2-ant and 4-ant diversity UE. By varying the gain g , the received pilot strength can be controlled to 2-ant diversity UE and 4-ant diversity UE. For 2-ant diversity UE only C_{OVSF1} is used and thus the second term in Eq. ([8]) is removed. On the other hand, for 4-ant diversity UE, both C_{OVSF1} and C_{OVSF2} will be used and it can discriminate 4 different antenna paths. Detail receiver structure of different diversity UE are described in next section.

6.1.1.2 Receiver Structure of CPICH

6.1.1.2.1 Receiver structure of 4-ant diversity UE

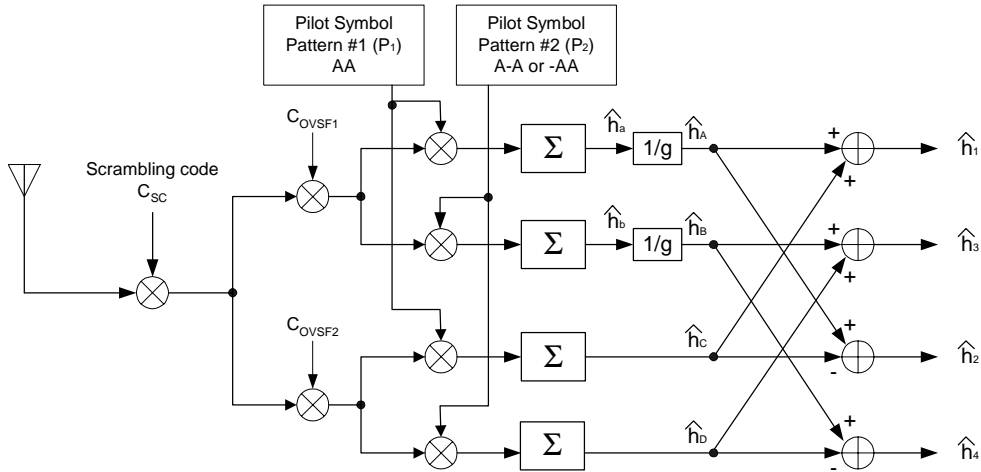

Figure 7. Receiver structure of 4-ant diversity UE

Figure 7 shows how the 4-ant diversity UE can receive and estimate the 4 channels. In Figure 7, \hat{h}_a, \hat{h}_b denote the channel estimation of $h_a = g(h_1 + h_2)$, $h_b = g(h_3 + h_4)$, respectively. Similarly, $\hat{h}_A, \hat{h}_B, \hat{h}_C, \hat{h}_D$ denote the estimation of $h_A = h_1 + h_2$, $h_B = h_3 + h_4$, $h_C = h_1 - h_2$, $h_D = h_3 - h_4$, respectively. Note that these channel estimation pairs $\{\hat{h}_a, \hat{h}_b\}$, $\{\hat{h}_A, \hat{h}_B, \hat{h}_C, \hat{h}_D\}$, or $\{\hat{h}_1, \hat{h}_2, \hat{h}_3, \hat{h}_4\}$ can be used to compensate the common or dedicated physical channels.

6.1.1.2.2 Receiver structure of 2-ant diversity UE

Figure 8 is the CPICH receiver structure of 2-ant diversity UE and it can also be used with the proposed CPICH transmission scheme without any change. Note that the channel estimation value with the receiver is exactly same as the output of the first branch output in Figure 7. That is, $h_a = g(h_1 + h_2)$ and $h_b = g(h_3 + h_4)$. Consequently, there's no change required to Release 99 UE in terms of pilot channel estimation. The only difference is the effective channel through which the pilot signal is transmitted. In order for the proposed CPICH transmission scheme to become fully backward compatible, UTRAN also should modify the transmission structure of common/dedicated physical channels with considering the channel estimation outputs of 2-ant diversity UE, and 4-ant diversity UE. The detail of the common/dedicated physical channel transmission structure is given in section 6.1.2 and 6.1.3.

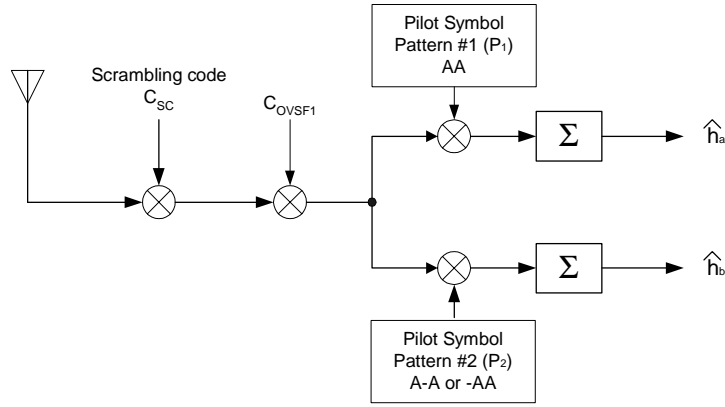

Figure 8. Receiver structure of 2-ant diversity UE

6.1.1.2.3 Summary of channel estimation outputs

Table 6. shows the summary of demodulation parameters and the channel estimation output according to the UE diversity mode. In Table 6 the related physical channel implies the physical channel that utilises the corresponding channel estimation output during demodulation. The main idea of the Table 6 is that the transmission structure of the related physical channel should be designed carefully with considering the corresponding channel estimation output.

Table 6. Summary of demodulation parameters and channel estimation output

Rx parameters UE mode	Pilot Channel				Related physical channel
	scrambling code	channelisation code	pilot pattern	channel estimation output	
2-ant diversity	C_{SC}	$C_{OVSF1} = C_{ch,256,0}$	AA A-A/-AA	$h_a = g(h_1 + h_2)$ $h_b = g(h_3 + h_4)$	Common CH Dedicated CH
4-ant diversity	C_{SC}	$C_{OVSF1} = C_{ch,256,0}$ $C_{OVSF2} = C_{ch,256,1}$	AA A-A/-AA	$h_a = g(h_1 + h_2)$ $h_b = g(h_3 + h_4)$	Common CH
				h_1, h_2, h_3, h_4	Dedicated CH

6.1.2 Common Physical Channel Tx Scheme

6.1.2.1 Common Physical Channel Tx Scheme

Common physical channel should be transmitted with one and only one transmission scheme. However, each UE should receive the common physical channel as their transmit diversity mode. Figure 9 is the proposed common physical channel transmission scheme where the original symbols (S_1, S_2) are transmitted to antenna 1 and 2, while the STTD encoded symbols ($-S_2^*, S_1^*$) are transmitted to antenna 3 and 4. Backward compatibility of this scheme can be easily proved and shown in section 6.1.2.2.

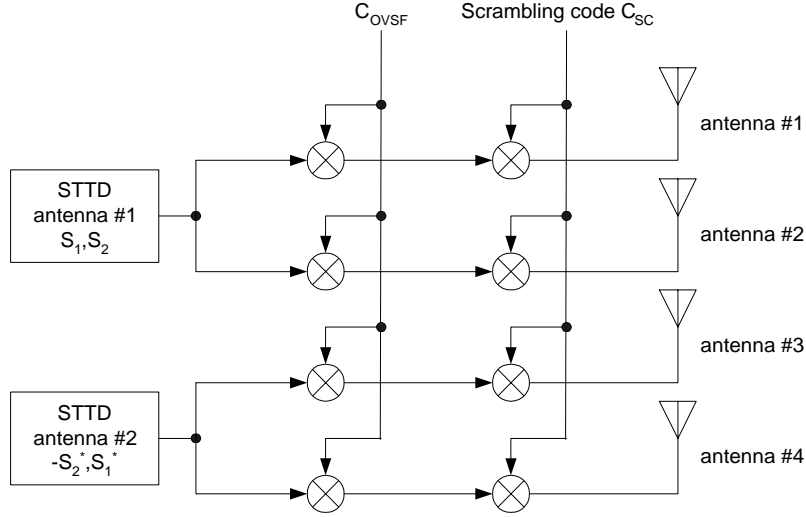

Figure 9. Common Physical Channel Transmission

6.1.2.2 Receiver Structure of Common Physical Channel Tx Scheme

If the common physical channel transmission scheme in Figure 9 is used, 2-ant and 4-ant diversity UE can receive the signals with the conventional STTD decoder as shown in Figure 10.

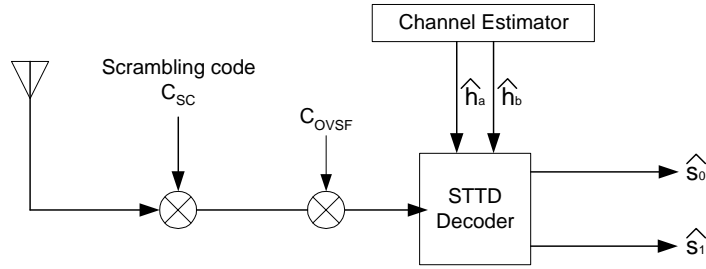

Figure 10. Receiver Structure for Common Physical Channel Transmission Scheme 1

The received signal after multiplication of OVSF in Figure 9 is given by

$$\begin{aligned}
 r_{t1} &= S_1(h_1 + h_2) - S_2^*(h_3 + h_4) = S_1 h_a - S_2^* h_b \\
 r_{t2} &= S_2(h_1 + h_2) + S_1^*(h_3 + h_4) = S_2 h_a + S_1^* h_b
 \end{aligned} \tag{9}$$

where $t1, t2$ denote the time unit. Since the channel estimation provided by 2-antenna CPICH receiver are \hat{h}_a and \hat{h}_b (See Table 6), conventional STTD receiver can be used without any change.

6.1.3 Dedicated Physical Channel Tx Scheme

In case of a dedicated physical channel, transmission scheme should be different for each UE according to the diversity mode. However, the transmission scheme should be carefully designed with considering the available channel estimation output as given in Table 6.

6.1.3.1 Dedicated Physical Channel Tx Scheme for R99/R4 UE

For R99/R4 UE which does not know the usage of 4 ant transmission in the Node-B, the available channel estimation is $h_a = g(h_1 + h_2)$, $h_b = g(h_3 + h_4)$ (See Table 6). It means that the antenna 1 and antenna 2 should transmit one signal, and antenna 3 and antenna 4 should transmit the other signal. Based on the above constraint, Figure 11 and Figure 12 show the proposed transmission scheme for dedicated physical channel to 2-ant STTD and closed loop transmit diversity UE, respectively. By distributing 2-antenna signals to 4-antenna, such situation that the power of R99/R4 UE's concentrate on two antenna can be avoided. Definitely, it reduces the PAPR (Peak to Average Power Ratio)

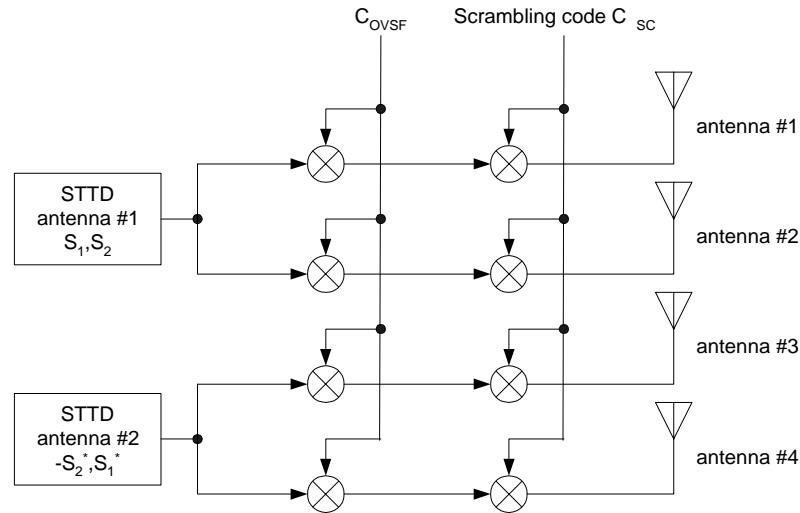

Figure 11. Dedicated physical channel transmission scheme for R99/R4 STTD diversity UE

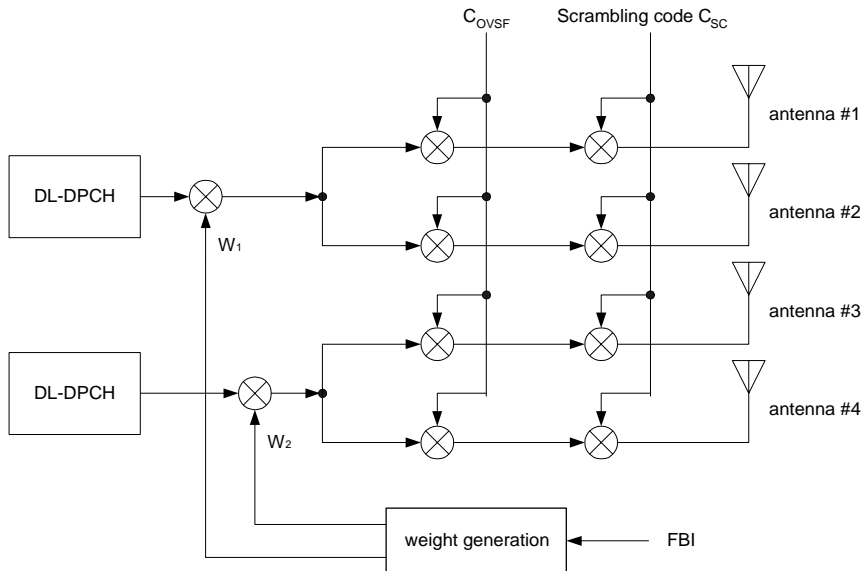

Figure 12. Dedicated physical channel transmission scheme for R99/R4 closed loop transmit diversity UE

6.1.3.2 Dedicated Physical Channel Transmission Scheme for beyond R99/R4 UE

If a dedicated physical channel is transmitted to a beyond R99/R4 diversity UE which assumes knowing the usage of 4 ant transmission in the Node-B, e.g. R5 and/or R6, the transmission scheme should be designed with considering the available channel estimations output to the UE. With the proposed CPiCH transmission scheme, the available channel estimation output of the beyond R99/R5 UE are $\hat{h}_1, \hat{h}_2, \hat{h}_3, \hat{h}_4$ (See Table 6). Currently, there is no accepted 4-antenna open/closed loop transmit diversity scheme but the proposed CPiCH transmission scheme can be used with any kind of open/closed loop diversity proposal.

6.2 New pilot scheme for 4-Tx-antennas

To keep the specification as simple and effective as possible we propose not to extend Tx diversity for 4-antennas to the all channels – instead we suggest to keep all the general measurements as indicated in Rel-99/4 specification. Only channels that could arguably benefit from 4-antenna Tx-diversity (e.g. DPCH and DSCH) are proposed to be extended. P-CPiCH is would remain basically unchanged and could be used as a reference for measurements in Rel-99/4 UEs as well.

It seems evident that different 4-Tx-diversity concept state different requirements for pilots. One important requirement is the possibility for good channel estimations for additional channels. We propose to utilize dedicated pilots for the additional channels, and recommend to justify slot formats that are favorable for each concept, including possibility to utilize power offsets for dedicated pilots.

The use of S-CPiCH will add the overall power loss of a cell when reserving acceptable P-CPiCH level, hence its use is recommended only for the situations when no Rel'99 terminals are in the cell coverage area or when a proposed scheme offers big enough gain to compensate for S-CPiCH energy.

6.2.1 Description of the proposed pilot transmission scheme

This section contains the description of the non-symmetric orthogonal pilots. Let a pseudo-antenna configuration be defined by

$$\begin{cases} A_a := A_1 + A_2 \\ A_b := A_3 + A_4 \\ A_c := A_1 - A_2 \\ A_d := A_3 - A_4 \end{cases} \quad (1)$$

where A_1, \dots, A_4 are the physical antennas; another configuration would be e.g. $A_a := A_1, A_b := A_2, A_c := A_3$ and $A_d := A_4$.

Then primary common pilots are spread over all antennas as shown in figure 1 - hence P-CPiCH separates two orthogonal channels via four physical antennas such that P-CPiCH power is evenly distributed over them. Therefore, 2-Tx-antenna schemes (for Rel-99/4) utilize two sum channels (see [17]) (i.e., the corresponding dedicated channels are transmitted over four antennas, the first diversity branch via antennas 1&2, and the second via antennas 3&4). This arrangement guarantees good power balance.

In order to guarantee Rel-99/4 UE's full functionality (as long they are in the market), P-CPiCH energy should be adjusted as for 2-Tx-cells. All general measurements from common channels (e.g. SHO evaluation, idle mode cell re-selection and synchronization as indicated in [10]) are done using only the proposed P-CPiCH scheme – so there is no need to extend all the channels for 4-Tx-diversity schemas and the corresponding Rel-99/4 functionality can be maintained in later releases.

Dedicated pilots are proposed to be utilized in order to separate two additional channels, possibly with the help of S-CPiCH (e.g. according to the operators choice and to the amount of rel'99 UE's in the cell area; S-CPiCH energy may be time variant) with adjustable gain factor g as presented in figure 2 ($g = g(t)$ is possibly time varying). Note that specifying $g=f$ we get the pilot extension scheme already described above. Dedicated pilots can be powered by 0-6 dB offsets (as allowed already in Rel-99/4 specification) and short pilot symbol intervals (e.g. two symbols) will not be allowed – each dedicated pilot arrangement is designed based on the corresponding Tx-diversity schema.

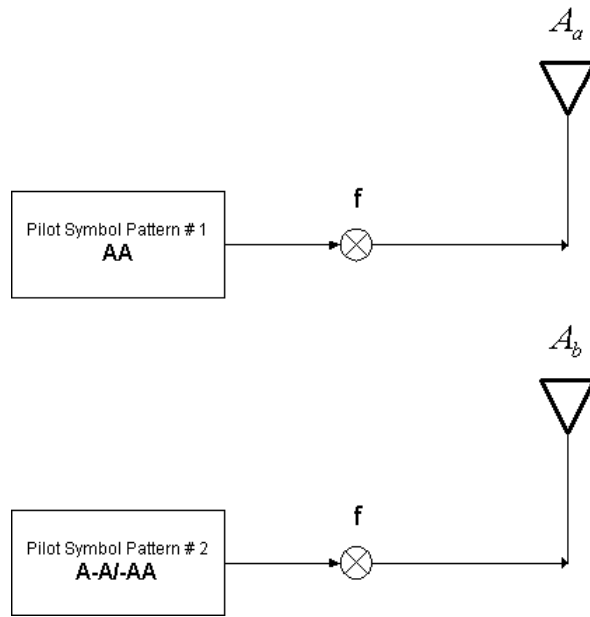

Figure 1. Transmission of P-CPiCH via pseudo-antennas A_a, A_b .

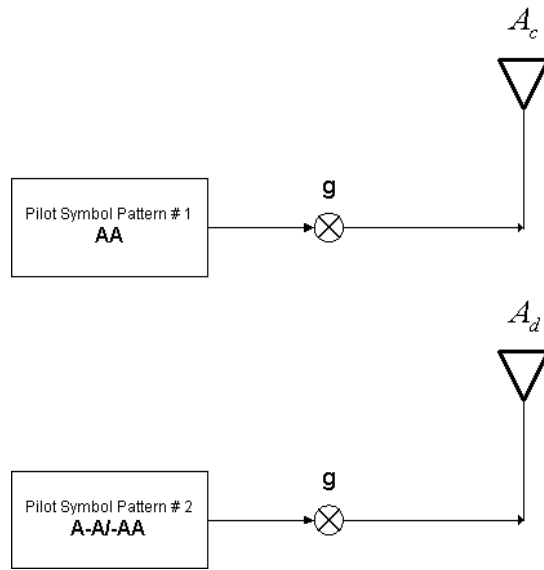

Figure 2. Transmission of S-CPiCH via two pseudo-antennas A_c, A_d with adjustable gain factor g .

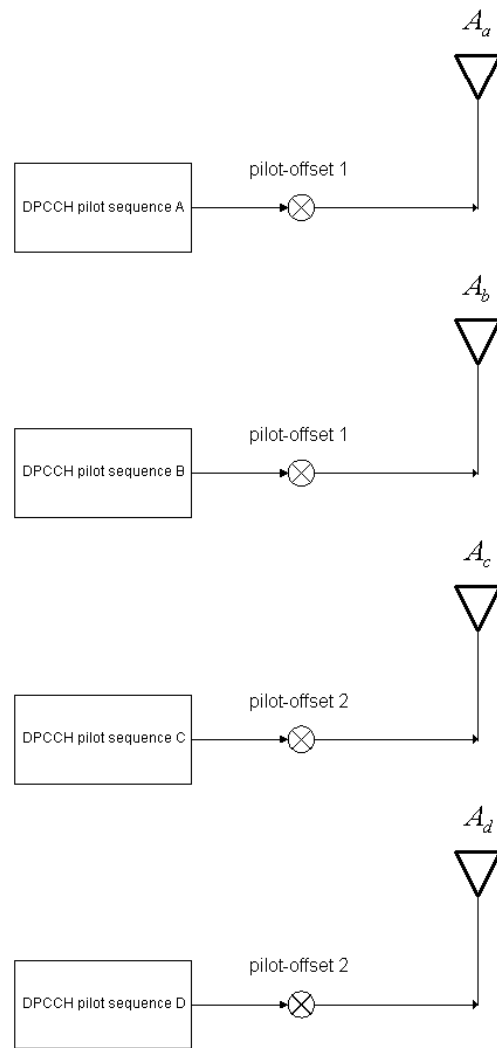

Figure 3. Transmission of DPCCH pilots via two or four pseudo-antennas A_a, A_b, A_c, A_d with adjustable pilot offsets. Four orthogonal Hadamard sequences are used as pilot symbols.

6.3 New CPICH Transmission scheme for > 2 Tx antennas

In Release 99 specification, transmit diversity using 2 antennas is included. For an extension of transmit diversity schemes using more than 2 transmit antennas the definition of a new CPICH transmission scheme is essential. The UE must be enabled to perform channel estimation for each antenna. In this section, a new CPICH transmission scheme is described for 4-antenna transmit diversity. The shown principles can be also applied to more than 4 antennas.

The following principles apply:

- definition of the orthogonal pilots for CPICH using OVSF codes
- same pilot patterns (modulation with AA and A-A/-AA) as in Release 99 are used
- definition of unequal CPICH power ratio between CPICH1&2 and CPICH3&4
- possibility to utilize only dedicated pilots

A detailed example of the new CPICH transmission scheme for four antennas that also has the advantage of reduced PAPR and balancing the power of the antennas at the Node B is described in section 6.1.

6.3.1 Definition of new orthogonal pilot sequences

The definition of new orthogonal pilot sequences is described in this section. The extension to four antennas is shown in Figure 1. One can see the modulated CPICH for two antennas as specified in Rel99/4, which is denoted here as CPICH1 and CPICH2. Hereby the two different pilot symbol patterns are spread using channelisation code $C_{ch,256,0}$.

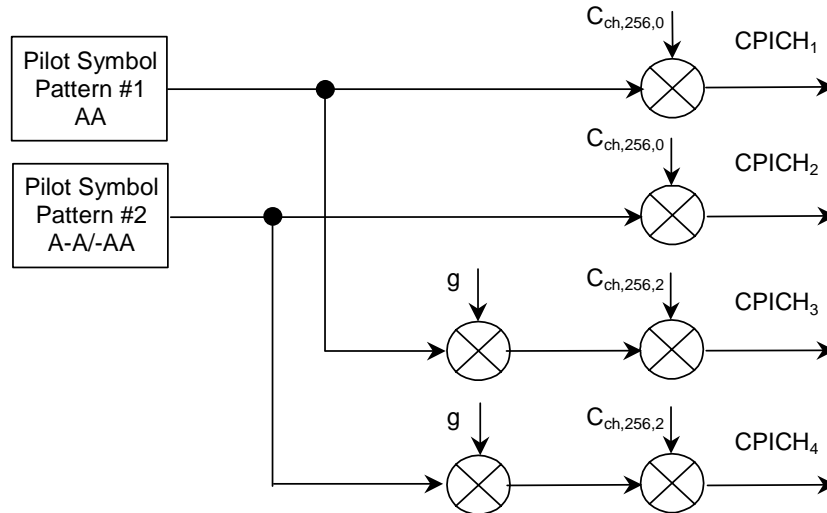

Figure 1: Orthogonal pilots for 4 antennas

When using four antennas, two additional orthogonal pilot sequences are defined. The same pilot symbol patterns as in Rel99/4 spread by a different channelisation code are used. To keep the complexity at the UE simple a channelisation code as close as possible in the code tree to $C_{ch,256,0}$ is desired. However, code $C_{ch,256,1}$ is already reserved for the Primary CCPCH, so the next available one is $C_{ch,256,2}$. This code is therefore used for spreading of CPICH3 and CPICH4. The resulting structure can be seen in Figure 1.

Note that scrambling is done with the same scrambling code for all channels and is not shown in Figure 1.

For the Rel 99/4 DPCH it shall be possible to use CPICH1 and CPICH 2 as a phase reference. If CPICH is used as a phase reference for a DPCH using four antennas it shall be possible for the UE to use CPICH 1, 2, 3 and 4.

All common channels (other than pilot) are using CPICH1 and CPICH2 as phase reference.

It is still possible for the UTRAN to use non-standardised beamforming techniques. Hereby a S-CPICH or dedicated pilot bits can be used as phase reference for a DPCH.

The need for a further extension to more than 4 antennas is ffs.

6.3.2 Unequal power setting for CPICH

The total power of the CPICH 1,2,...,4 can be configured by the network. The power of CPICH3&4 can be adjusted relative to the power of CPICH1&2 by the gain factor g with $0 \leq g \leq 1$. It is ffs whether good performance of TX diversity techniques requires that the value of g is signalled to the UE.

Examples:

If $g = 1$ the power on CPICH 3&4 is the same as the power on CPICH 1&2 and therefore the CPICH power is equally distributed with ration 50:50.

If $g = 0.25$ a power ratio between CPICH 1&2 and CPICH 3&4 of 80:20 is obtained.

The case of unequal power allocation is also covered in the simulations (section 7.1.1).

7 Performance

8 Impacts to UE and UTRAN implementation

9 Impacts to physical layer operation

10 Backwards compatibility to R99/R4

10.1 Eigenbeamformer concept

With the eigenbeamformer no backward compatibility problem is identified for Release-99.

10.2 Basis selection scheme for > 2 Tx antennas

10.3 New CPiCH Transmission scheme for > 2 Tx antennas

This proposed scheme satisfies the backward compatibility with Release 99 2-ant diversity UE. The proper common/dedicated physical channel transmission scheme is also considered to be used with the proposed CPiCH transmission scheme. With only one additional channelisation code, the proposed CPiCH transmission scheme can be used as diversity pilot for 4 transmit antenna.

10.4 4-Tx-STTD concept

Pilot backward (rel'99) compatibility problem (meaning that decreasing of P-CPiCH transmit power for rel'99 UE's) can fully be avoided e.g. by utilizing the dedicated pilots for the two additional channels. Indeed, decoding of 4-Tx-STTD is requiring only two channel estimates for rel'99 STTD-decoder.

10.5 Closed loop mode 1 for > 2 Tx antennas

As Rel.-99 closed loop mode 1 is one instance (i.e. R2F2T2) of R2FNMTM solutions there are no special backwards compatibility problems.

11 Evaluations of the described schemes

[tbd]

History

Document history		
Date	Version	Comment
	0.1.0	First draft
Nov. 22, 2001	0.1.1	Revised version
Feb. 21, 2002	0.2.1	Merged version
Feb. 22, 2002	1.0.0	Updated version to informative present in the plenary
Editor for 3G TR 25.869 is: Sung Jin Kim		
Tel. : +82-31-280-8175 Fax : +82-31-280-9207 Email : communication@samsung.com		
This document is written in Microsoft Word version.		