

TSG-RAN Meeting #11
Palm Springs, CA, U.S.A., 13-16 March 2001

RP-010096

Title: CRs (Rel-4) for WI "UMTS 1800"

Source: TSG-RAN WG4

Agenda item: 6.1.3

WI Acronym: RInImp-UMTS18

Doc-2nd-Level	Spec	CR	Subject	Cat	Version-	Version-
R4-010466	25.101	95	REL 4 Document restructure and changes	B	3.5.0	4.0.0
R4-010447	25.104	62	TS25.104 REL 4 - Document structure	B	3.5.0	4.0.0

CHANGE REQUEST

⌘ **25.101 CR 95** ⌘ rev **-** ⌘ Current version: **3.5.0** ⌘

For **HELP** on using this form, see bottom of this page or look at the pop-up text over the ⌘ symbols.

Proposed change affects: ⌘ (U)SIM ME/UE Radio Access Network Core Network

Title:	⌘ REL 4 Document restructure and changes		
Source:	⌘ RAN WG4		
Work item code:	⌘ RInImp-UMTS18	Date:	⌘ 14-02-01
Category:	⌘ B	Release:	⌘ REL-4
<p>Use <u>one</u> of the following categories:</p> <p>F (essential correction) A (corresponds to a correction in an earlier release) B (Addition of feature), C (Functional modification of feature) D (Editorial modification)</p> <p>Detailed explanations of the above categories can be found in 3GPP TR 21.900.</p>		<p>Use <u>one</u> of the following releases:</p> <p>2 (GSM Phase 2) R96 (Release 1996) R97 (Release 1997) R98 (Release 1998) R99 (Release 1999) REL-4 (Release 4) REL-5 (Release 5)</p>	

Reason for change:	⌘ Addition of expansion bands to UE requirement which include UMTS-1800		
Summary of change:	⌘ Re-structure of document, revised performance requirement for PCS and DCS band. Editorial corrections		
Consequences if not approved:	⌘ Specification required for implementation		

Clauses affected:	⌘ Section 3.2, 5, 6 and 7 relating to frequency dependant parameters. Other sections as per REL99														
Other specs affected:	<table style="border: none;"> <tr> <td style="border: 1px solid black; width: 20px; text-align: center;"><input type="checkbox"/></td> <td style="padding-left: 5px;">Other core specifications</td> <td style="border: none; padding-left: 20px;">⌘</td> <td style="border: none;"></td> </tr> <tr> <td style="border: 1px solid black; text-align: center;"><input checked="" type="checkbox"/></td> <td style="padding-left: 5px;">Test specifications</td> <td style="border: none; padding-left: 20px;">⌘</td> <td style="border: none;">TS34.121</td> </tr> <tr> <td style="border: 1px solid black; text-align: center;"><input type="checkbox"/></td> <td style="padding-left: 5px;">O&M Specifications</td> <td style="border: none; padding-left: 20px;">⌘</td> <td style="border: none;"></td> </tr> </table>	<input type="checkbox"/>	Other core specifications	⌘		<input checked="" type="checkbox"/>	Test specifications	⌘	TS34.121	<input type="checkbox"/>	O&M Specifications	⌘			
<input type="checkbox"/>	Other core specifications	⌘													
<input checked="" type="checkbox"/>	Test specifications	⌘	TS34.121												
<input type="checkbox"/>	O&M Specifications	⌘													
Other comments:	⌘														

How to create CRs using this form:

Comprehensive information and tips about how to create CRs can be found at: http://www.3gpp.org/3G_Specs/CRs.htm. Below is a brief summary:

- 1) Fill out the above form. The symbols above marked ⌘ contain pop-up help information about the field that they are closest to.
- 2) Obtain the latest version for the release of the specification to which the change is proposed. Use the MS Word "revision marks" feature (also known as "track changes") when making the changes. All 3GPP specifications can be downloaded from the 3GPP server under <ftp://www.3gpp.org/specs/> For the latest version, look for the directory name with the latest date e.g. 2000-09 contains the specifications resulting from the September 2000 TSG meetings.

- 3) With "track changes" disabled, paste the entire CR form (use CTRL-A to select it) into the specification just in front of the clause containing the first piece of changed text. Delete those parts of the specification which are not relevant to the change request.

3.2 Abbreviations

For the purposes of the present document, the following abbreviations apply:

ACLR	Adjacent Channel Leakage power Ratio
ACS	Adjacent Channel Selectivity
AICH	Acquisition Indication Channel
BER	Bit Error Ratio
BLER	Block Error Ratio
CW	Continuous Wave (un-modulated signal)
DCH	Dedicated Channel, which is mapped into Dedicated Physical Channel.
DL	Down Link (forward link)
DTX	Discontinuous Transmission
DPCCH	Dedicated Physical Control Channel
DPCCH	Dedicated Physical Channel
$DPCH_E_c$	Average energy per PN chip for DPCCH.
$\frac{DPCH_E_c}{I_{or}}$	The ratio of the transmit energy per PN chip of the DPCCH to the total transmit power spectral density at the Node B antenna connector.
DPDCH	Dedicated Physical Data Channel
EIRP	Effective Isotropic Radiated Power
E_c	Average energy per PN chip.
$\frac{E_c}{I_{or}}$	The ratio of the average transmit energy per PN chip for different fields or physical channels to the total transmit power spectral density.
FACH	Forward Access Channel
FDD	Frequency Division Duplex
FDR	False transmit format Detection Ratio
F_{uw}	Frequency of unwanted signal. This is specified in bracket in terms of an absolute frequency(s) or a frequency offset from the assigned channel frequency.
Information Data Rate	Rate of the user information, which must be transmitted over the Air Interface. For example, output rate of the voice codec.
I_o	The total received power spectral density, including signal and interference, as measured at the UE antenna connector.
I_{oc}	The power spectral density of a band limited white noise source (simulating interference from cells, which are not defined in a test procedure) as measured at the UE antenna connector.
I_{or}	The total transmit power spectral density of the down link at the Node B antenna connector.
\hat{I}_{or}	The received power spectral density of the down link as measured at the UE antenna connector.
MER	Message Error Ratio
Node B	A logical node responsible for radio transmission / reception in one or more cells to/from the User Equipment. Terminates the Iub interface towards the RNC
OCNS	Orthogonal Channel Noise Simulator, a mechanism used to simulate the users or control signals on the other orthogonal channels of a downlink link.
$OCNS_E_c$	Average energy per PN chip for the OCNS.
$\frac{OCNS_E_c}{I_{or}}$	The ratio of the average transmit energy per PN chip for the OCNS to the total transmit power spectral density.
P-CCPCH	Primary Common Control Physical Channel
PCH	Paging Channel
$P-CCPCH \frac{E_c}{I_o}$	The ratio of the received P-CCPCH energy per chip to the total received power spectral density at the UE antenna connector.

$\frac{P-CCPCH_{-}E_c}{I_{or}}$ The ratio of the average transmit energy per PN chip for the P-CCPCH to the total transmit power spectral density.

P-CPICH Primary Common Pilot Channel

PICH Paging Indicator Channel

PPM Parts Per Million

RACH Random Access Channel

<REFSENS> Reference sensitivity

<REF \hat{I}_{or} > Reference \hat{I}_{or}

SCH Synchronization Channel consisting of Primary and Secondary synchronization channels

S-CCPCH Secondary Common Control Physical Channel.

S-CCPCH- E_c Average energy per PN chip for S-CCPCH.

SIR Signal to Interference ratio

SSDT Site Selection Diversity Transmission

STTD Space Time Transmit Diversity

TDD Time Division Duplexing

TFC Transport Format Combination

TFCI Transport Format Combination Indicator

TPC Transmit Power Control

TSTD Time Switched Transmit Diversity

UE User Equipment

UL Up Link (reverse link)

UTRA UMTS Terrestrial Radio Access

5 Frequency bands and channel arrangement

5.1 General

The information presented in this subclause is based on a chip rate of 3.84 Mcps.

NOTE: Other chip rates may be considered in future releases.

5.2 Frequency bands

- a) UTRA/FDD is designed to operate in ~~either of~~ the following paired bands:

<u>Frequency Band</u>	<u>UL Frequencies</u> <u>UE transmit, Node B receive</u>	<u>DL frequencies</u> <u>UE receive, Node B transmit</u>
<u>I</u>	<u>1920 – 1980 MHz</u>	<u>2110 –2170 MHz</u>
<u>II</u>	<u>1850 –1910 MHz</u>	<u>1930 –1990 MHz</u>
<u>III</u>	<u>1710-1785 MHz</u>	<u>1805-1880 MHz</u>

- b) Deployment in other frequency bands is not precluded.

5.3 TX–RX frequency separation

- a) UTRA/FDD is designed to operate with the following TX-RX frequency separation

<u>Frequency Band</u>	<u>TX-RX frequency separation</u>
<u>I</u>	<u>190 MHz</u>
<u>II</u>	<u>80 MHz.</u>
<u>III</u>	<u>95 MHz.</u>

- (a) ~~The minimum transmit to receive frequency separation is 134.8 MHz and the maximum value is 245.2 MHz and all UE(s) shall support a TX-RX frequency separation of 190 MHz when operating in the paired band defined in subclause 5.2(a).~~
- (b) ~~When operating in the paired band defined in subclause 5.2 (b), all UE(s) shall support a TX-RX frequency separation of 80 MHz.~~
- (eb) UTRA/FDD can support both fixed and variable transmit to receive frequency separation.
- (ec) The use of other transmit to receive frequency separations in existing or other frequency bands shall not be precluded.

5.4 Channel arrangement

5.4.1 Channel spacing

The nominal channel spacing is 5 MHz, but this can be adjusted to optimise performance in a particular deployment scenario.

5.4.2 Channel raster

The channel raster is 200 kHz, which means that the centre frequency must be an integer multiple of 200 kHz.

5.4.3 Channel number

The carrier frequency is designated by the UTRA Absolute Radio Frequency Channel Number (UARFCN). The values ~~of the UARFCN in the IMT2000 band is~~ are defined as follows:

Table 5.1: UTRA Absolute Radio Frequency Channel Number UARFCN definition

Uplink	$N_u = 5 * F_{\text{uplink}}$	$0.0 \text{ MHz} \leq F_{\text{uplink}} \leq 3276.6 \text{ MHz}$ where F_{uplink} is the uplink frequency in MHz
Downlink	$N_d = 5 * F_{\text{downlink}}$	$0.0 \text{ MHz} \leq F_{\text{downlink}} \leq 3276.6 \text{ MHz}$ where F_{downlink} is the downlink frequency in MHz

5.4.4 UARFCN

The following UARFCN range shall be supported for each paired band

Table 5.2: UTRA Absolute Radio Frequency Channel Number

<u>Frequency Band</u>	<u>Uplink</u> <u>UE transmit, Node B</u> <u>receive</u>	<u>Downlink</u> <u>UE receive, Node B</u> <u>transmit</u>
<u>I</u>	<u>9612 to 9888</u>	<u>10562 to 10838</u>

II	9262 to 9538	9662 to 9938
III	8562 to 8913	9037 to 9388

6 Transmitter characteristics

6.1 General

Unless detailed the transmitter characteristic are specified at the antenna connector of the UE. For UE with integral antenna only, a reference antenna with a gain of 0 dBi is assumed. Transmitter characteristics for UE(s) with multiple antennas/antenna connectors are FFS.

The UE antenna performance has a significant impact on system performance, and minimum requirements on the antenna efficiency are therefore intended to be included in future versions of the present document. It is recognised that different requirements and test methods are likely to be required for the different types of UE.

All the parameters in clause 6 are defined using the UL reference measurement channel (12.2 kbps) specified in subclause A.2.1 and unless stated with the UL power control ON

6.2 Transmit power

6.2.1 UE maximum output power

The following Power Classes define the maximum output power.

Table 6.1: UE Power Classes

Power Class	Maximum output power	Tolerance
1	+33 dBm	+1/-3 dB
2	+27 dBm	+1/-3 dB
3	+24 dBm	+1/-3 dB
4	+21 dBm	± 2 dB

NOTE: The tolerance of the maximum output power is below the prescribed value even for the multi-code transmission mode.

6.3 Frequency Error

The UE modulated carrier frequency shall be accurate to within ± 0.1 PPM observed over a period of one timeslot compared to the carrier frequency received from the Node B. These signals will have an apparent error due to Node B frequency error and Doppler shift. In the later case, signals from the Node B must be averaged over sufficient time that errors due to noise or interference are allowed for within the above ± 0.1 PPM figure. The UE shall use the same frequency source for both RF frequency generation and the chip clock.

Table 6.2: Frequency Error

AFC	Frequency stability
ON	within ± 0.1 PPM

6.4 Output power dynamics

Power control is used to limit the interference level.

6.4.1 Open loop power control

Open loop power control is the ability of the UE transmitter to sets its output power to a specific value. The open loop power control tolerance is given in Table 6.3

6.4.1.1 Minimum requirement

The UE open loop power is defined as the average power in a timeslot or ON power duration, whichever is available, and they are measured with a filter that has a Root-Raised Cosine (RRC) filter response with a roll off $\alpha = 0.22$ and a bandwidth equal to the chip rate.

Table 6.3: Open loop power control tolerance

Normal conditions	± 9 dB
Extreme conditions	± 12 dB

6.4.2 Inner loop power control in the uplink

Inner loop power control in the Uplink is the ability of the UE transmitter to adjust its output power in accordance with one or more TPC commands received in the downlink.

6.4.2.1 Power control steps

The power control step is the change in the UE transmitter output power in response to a single TPC command, TPC_cmd, derived at the UE.

6.4.2.1.1 Minimum requirement

The UE transmitter shall have the capability of changing the output power with a step size of 1, 2 and 3 dB according to the value of Δ_{TPC} or $\Delta_{\text{RP-TPC}}$, in the slot immediately after the TPC_cmd can be derived

- (a) The transmitter output power step due to inner loop power control shall be within the range shown in Table 6.4.
- (b) The transmitter average output power step due to inner loop power control shall be within the range shown in Table 6.5. Here a TPC_cmd group is a set of TPC_cmd values derived from a corresponding sequence of TPC commands of the same duration.

The inner loop power step is defined as the relative power difference between the average power of the original (reference) timeslot and the average power of the target timeslot, not including the transient duration. The transient duration is from 25 μ s before the slot boundary to 25 μ s after the slot boundary. The power is measured with a filter that has a Root-Raised Cosine (RRC) filter response with a roll off $\alpha = 0.22$ and a bandwidth equal to the chip rate

Table 6.4: Transmitter power control range

TPC_cmd	Transmitter power control range					
	1 dB step size		2 dB step size		3 dB step size	
	Lower	Upper	Lower	Upper	Lower	Upper
+ 1	+0.5 dB	+1.5 dB	+1 dB	+3 dB	+1.5 dB	+4.5 dB
0	-0.5 dB	+0.5 dB	-0.5 dB	+0.5 dB	-0.5 dB	+0.5 dB
-1	-0.5 dB	-1.5 dB	-1 dB	-3 dB	-1.5 dB	-4.5 dB

Table 6.5: Transmitter average power control range

TPC_cmd group	Transmitter power control range after 10 equal TPC_cmd groups				Transmitter power control range after 7 equal TPC_cmd groups	
	1 dB step size		2 dB step size		3 dB step size	
	Lower	Upper	Lower	Upper	Lower	Upper
+1	+8 dB	+12 dB	+16 dB	+24 dB	+16 dB	+26 dB
0	-1 dB	+1 dB	-1 dB	+1 dB	-1 dB	+1 dB
-1	-8 dB	-12 dB	-16 dB	-24 dB	-16 dB	-26 dB
0,0,0,0,+1	+6 dB	+14 dB	N/A	N/A	N/A	N/A
0,0,0,0,-1	-6 dB	-14 dB	N/A	N/A	N/A	N/A

6.4.3 Minimum transmit output power

The minimum controlled output power of the UE is when the power control setting is set to a minimum value. This is when both the inner loop and open loop power control indicate a minimum transmit output power is required.

6.4.3.1 Minimum requirement

The minimum transmit power is defined as an averaged power in a time slot measured with a filter that has a Root-Raised Cosine (RRC) filter response with a roll off $\alpha = 0.22$ and a bandwidth equal to the chip rate. The minimum transmit power shall be better than -50 dBm.

6.4.4 Out-of-synchronization handling of output power

The UE shall monitor the DPCCCH quality in order to detect a loss of the signal on Layer 1, as specified in TS 25.214. The thresholds Q_{out} and Q_{in} specify at what DPCCCH quality levels the UE shall shut its power off and when it shall turn its power on respectively. The thresholds are not defined explicitly, but are defined by the conditions under which the UE shall shut its transmitter off and turn it on, as stated in this subclause.

6.4.4.1 Minimum requirement

The parameters in Table 6.6 are defined using the DL reference measurement channel (12.2) kbps specified in subclause A.3.1 and with static propagation conditions.

Table 6.6: DCH parameters for test of Out-of-synch handling

Parameter	Unit	Value
\hat{I}_{or}/I_{oc}	dB	-1
I_{oc}	dBm/3.84 MHz	-60
$\frac{DPDCH - E_c}{I_{or}}$	dB	See figure 6.1: Before point A -16.6 After point A Not defined
$\frac{DPCCCH - E_c}{I_{or}}$	dB	See figure 6.1
Information Data Rate	kbps	12.2
TFCI	-	on

The conditions for when the UE shall shut its transmitter on and when it shall turn it on are defined by the parameters in Table 6.6 together with the DPCH power level as defined in Figure 6.1.

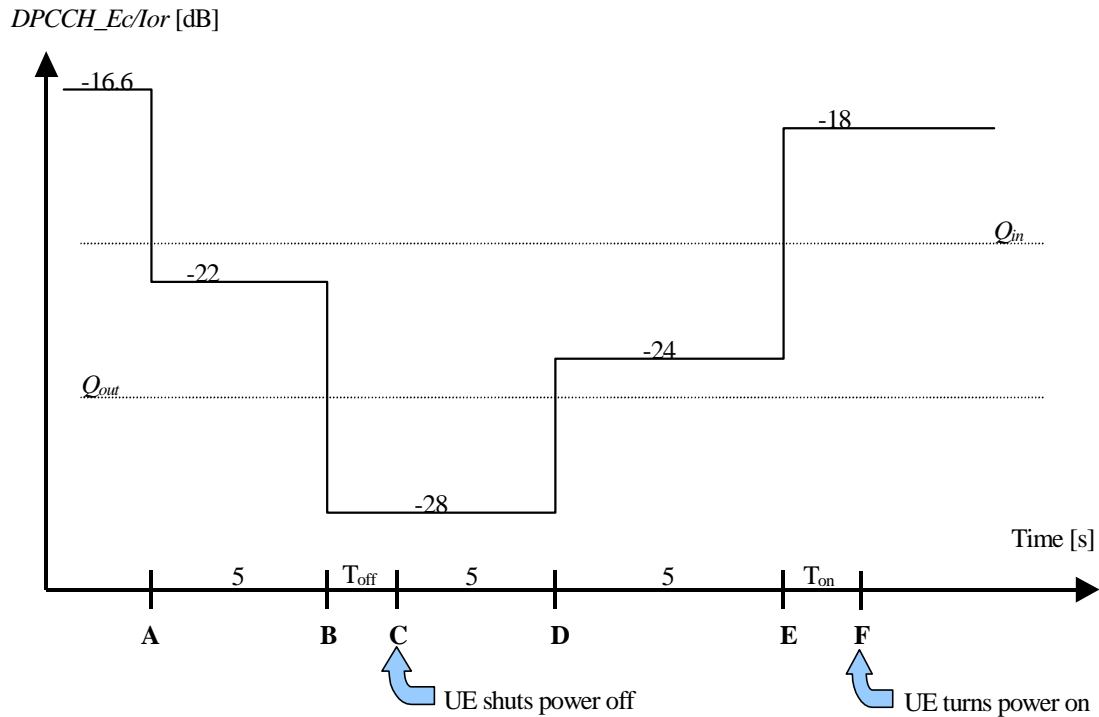

Figure 6.1: Conditions for out-of-synch handling in the UE. The indicated thresholds Q_{out} and Q_{in} are only informative

The requirements for the UE are that:

1. The UE shall not shut its transmitter off before point B.
2. The UE shall shut its transmitter off before point C, which is $T_{off} = 200$ ms after point B.
3. The UE shall not turn its transmitter on between points C and E.
4. The UE shall turn its transmitter on before point F, which is $T_{on} = 200$ ms after point E.

6.5 Transmit ON/OFF power

6.5.1 Transmit OFF power

The transmit OFF power state is when the UE does not transmit except during UL compressed mode. This parameter is defined as the maximum output transmit power within the channel bandwidth when the transmitter is OFF.

6.5.1.1 Minimum requirement

The transmit OFF power is defined as an averaged power in a duration of at least a timeslot excluding any transient periods, measured with a filter that has a Root-Raised Cosine (RRC) filter response with a roll off $\alpha = 0.22$ and a bandwidth equal to the chip rate. The requirement for the transmit OFF power shall be better than -56 dBm.

6.5.2 Transmit ON/OFF Time mask

The time mask for transmit ON/OFF defines the ramping time allowed for the UE between transmit OFF power and transmit ON power. Possible ON/OFF scenarios are RACH, CPCH or UL compressed mode.

6.5.2.1 Minimum requirement

The transmit power levels versus time shall meet the mask specified in figure 6.2 for PRACH preambles and CPCH preambles, and the mask in figure 6.3 for all other cases. The signal is measured with a filter that has a Root-Raised Cosine (RRC) filter response with a roll off $\alpha = 0.22$ and a bandwidth equal to the chip rate.

On power is defined as either case as follows. The specification depends on each possible case.

- First preamble of RACH/CPCH: Open loop accuracy (Table 6.3).
- During preamble ramping of the RACH/CPCH, and between final RACH/CPCH preamble and RACH/CPCH message part: Accuracy depending on size of the required power difference.(Table 6.7). The step in total transmitted power between final RACH/CPCH preamble and RACH/CPCH message (control part + data part) shall be rounded to the closest integer dB value. A power step exactly half-way between two integer values shall be rounded to the closest integer of greater magnitude.
- After transmission gaps in compressed mode: Accuracy as in Table 6.9.
- Power step to Maximum Power: Maximum power accuracy (Table 6.1).

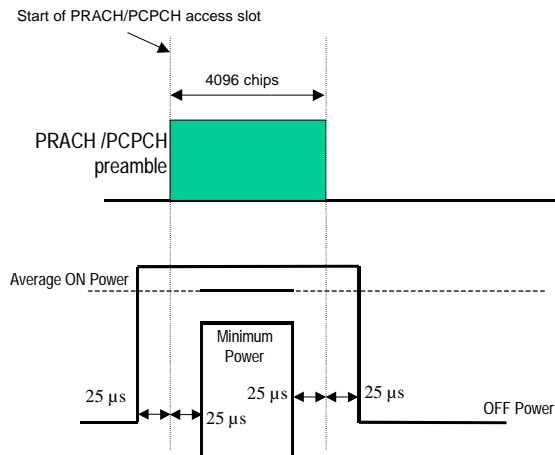

Figure 6.2: Transmit ON/OFF template for PRACH preambles and CPCH preambles

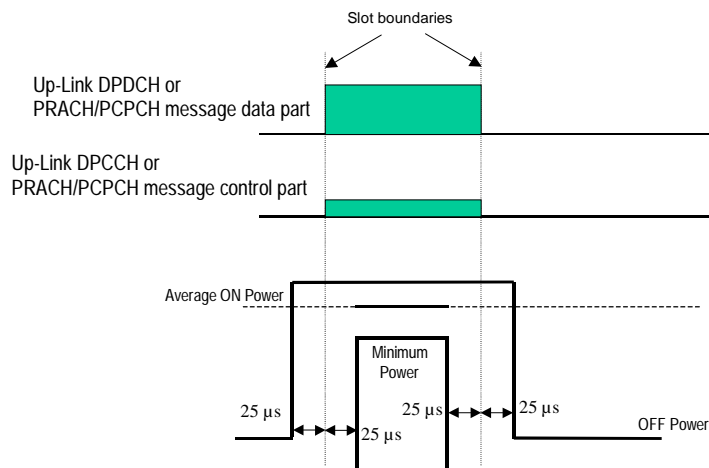

Figure 6.3: Transmit ON/OFF template for all other On/Off cases

Table 6.7: Transmitter power difference tolerance for RACH/CPCH preamble ramping, and between final RACH/CPCH preamble and RACH/CPCH message part

Power step size (Up or down)* ΔP [dB]	Transmitter power difference tolerance [dB]
0	+/- 1 dB
1	+/- 1 dB
2	+/- 1.5 dB
3	+/- 2 dB
$4 \leq \Delta P \leq 10$	+/- 2.5 dB
$11 \leq \Delta P \leq 15$	+/- 3.5 dB
$16 \leq \Delta P \leq 20$	+/- 4.5 dB
$21 \leq \Delta P$	+/- 6.5 dB

Note *: Power step size for RACH/CPCH preamble ramping is from 1 to 8 dB with 1 dB steps.

6.5.3 Change of TFC

A change of TFC (Transport Format Combination) in uplink means that the power in the uplink varies according to the change in data rate. DTX, where the DPCH is turned off, is a special case of variable data, which is used to minimise the interference between UE(s) by reducing the UE transmit power when voice, user or control information is not present.

6.5.3.1 Minimum requirement

A change of output power is required when the TFC, and thereby the data rate, is changed. The ratio of the amplitude between the DPDCH codes and the DPCCH code will vary. The power step due to a change in TFC shall be calculated in the UE so that the power transmitted on the DPCCH shall follow the inner loop power control. The step in total transmitted power (DPCCH + DPDCH) shall then be rounded to the closest integer dB value. A power step exactly half-way between two integer values shall be rounded to the closest integer of greater magnitude. The accuracy of the power step, given the step size, is specified in Table 6.8. The power change due to a change in TFC is defined as the relative power difference between the average power of the original (reference) timeslot and the average power of the target timeslot, not including the transient duration. The transient duration is from 25 μ s before the slot boundary to 25 μ s after the slot boundary. The power is measured with a filter that has a Root-Raised Cosine (RRC) filter response with a roll off $\alpha = 0.22$ and a bandwidth equal to the chip rate.

Table 6.8: Transmitter power step tolerance

Power step size (Up or down) ΔP [dB]	Transmitter power step tolerance [dB]
0	+/- 0.5 dB
1	+/- 0.5 dB
2	+/- 1.0 dB
3	+/- 1.5 dB
$4 \leq \Delta P \leq 10$	+/- 2.0 dB
$11 \leq \Delta P \leq 15$	+/- 3.0 dB
$16 \leq \Delta P \leq 20$	+/- 4.0 dB
$21 \leq \Delta P$	+/- 6.0 dB

The transmit power levels versus time shall meet the mask specified in Figure 6.4.

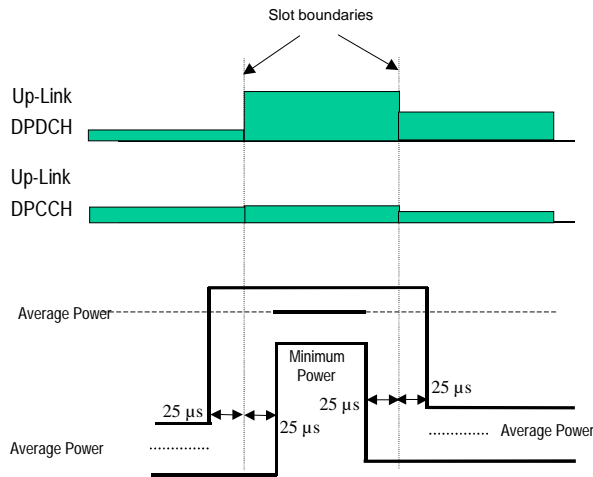

Figure 6.4: Transmit template during TFC change

6.5.4 Power setting in uplink compressed mode

Compressed mode in uplink means that the power in uplink is changed.

6.5.4.1 Minimum requirement

A change of output power is required during uplink compressed frames since the transmission of data is performed in a shorter interval. The ratio of the amplitude between the DPDCH codes and the DPCCH code will also vary. The power step due to compressed mode shall be calculated in the UE so that the energy transmitted on the pilot bits during each transmitted slot shall follow the inner loop power control.

Thereby, the power during compressed mode, and immediately afterwards, shall be such that the power on the DPCCH follows the steps due to inner loop power control combined with additional steps of $10\text{Log}_{10}(N_{\text{pilot,prev}} / N_{\text{pilot,curr}})$ dB where $N_{\text{pilot,prev}}$ is the number of pilot bits in the previously transmitted slot, and $N_{\text{pilot,curr}}$ is the current number of pilot bits per slot.

The resulting step in total transmitted power (DPCCH + DPDCH) shall then be rounded to the closest integer dB value. A power step exactly half-way between two integer values shall be rounded to the closest integer of greatest magnitude. The accuracy of the power step, given the step size, is specified in Table 6.8 in subclause 6.5.3.1. The power step is defined as the relative power difference between the average power of the original (reference) timeslot and the average power of the target timeslot, when neither the original timeslot nor the reference timeslot are in a transmission gap. The transient duration is not included, and is from 25μs before the slot boundary to 25μs after the slot boundary. The relative power is measured with a filter that has a Root-Raised Cosine (RRC) filter response with a roll off $\alpha = 0.22$ and a bandwidth equal to the chip rate.

In addition to any power change due to the ratio $N_{\text{pilot,prev}} / N_{\text{pilot,curr}}$, the average power of the DPCCH in the first slot after a compressed mode transmission gap shall differ from the average power in the last slot before the transmission gap by an amount Δ_{RESUME} , where Δ_{RESUME} is calculated as described in clause 5.1.2.3 of TS 25.214.

The resulting difference in the total transmitted power (DPCCH + DPDCH) shall then be rounded to the closest integer dB value. A power difference exactly half-way between two integer values shall be rounded to the closest integer of greatest magnitude. The accuracy of the resulting difference in the total transmitted power (DPCCH + DPDCH) after a transmission gap of up to 14 slots shall be as specified in Table 6.9.

Table 6.9: Transmitter power difference tolerance after a transmission gap of up to 14 slots

Tolerance on required difference in total transmitter power after a transmission gap
+/- 3 dB

The power difference is defined as the relative power difference between the average power of the original (reference) timeslot before the transmission gap and the average power of the target timeslot after the transmission gap, not including the transient durations. The transient durations at the start and end of the transmission gaps are each from 25 μ s before the slot boundary to 25 μ s after the slot boundary. The relative power is measured with a filter that has a Root-Raised Cosine (RRC) filter response with a roll off $\alpha = 0.22$ and a bandwidth equal to the chip rate.

The transmit power levels versus time shall meet the mask specified in figure 6.5

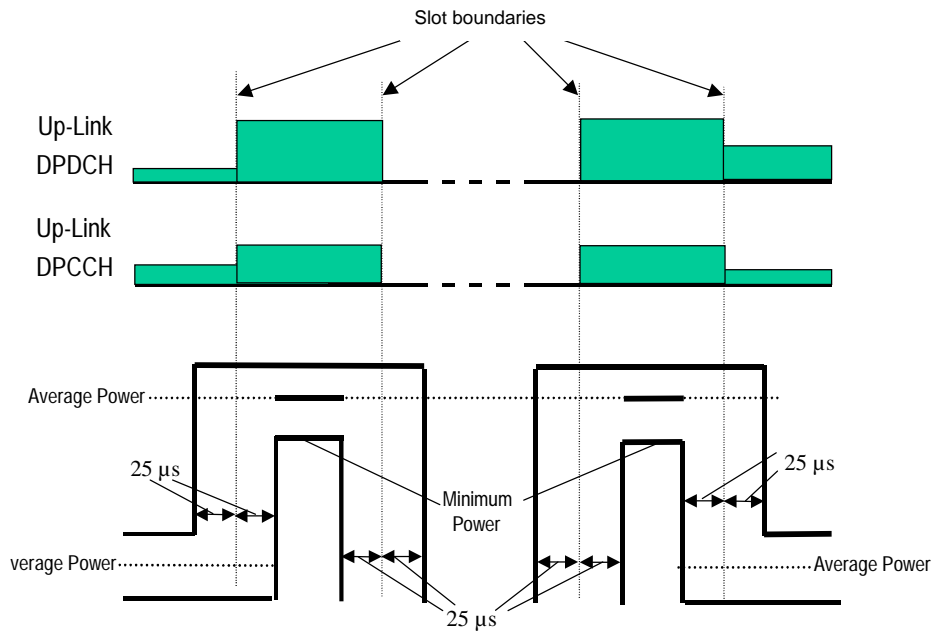

Figure 6.5: Transmit template during Compressed mode

6.6 Output RF spectrum emissions

6.6.1 Occupied bandwidth

Occupied bandwidth is a measure of the bandwidth containing 99 % of the total integrated power of the transmitted spectrum, centered on the assigned channel frequency. The occupied channel bandwidth shall be less than 5 MHz based on a chip rate of 3.84 Mcps.

6.6.2 Out of band emission

Out of band emissions are unwanted emissions immediately outside the nominal channel resulting from the modulation process and non-linearity in the transmitter but excluding spurious emissions. This out of band emission limit is specified in terms of a spectrum emission mask and Adjacent Channel Leakage power Ratio.

6.6.2.1 Spectrum emission mask

The spectrum emission mask of the UE applies to frequencies, which are between 2.5 MHz and 12.5 MHz away from the UE centre carrier frequency. The out of channel emission is specified relative to the UE output power measured in a 3.84 MHz bandwidth.

6.6.2.1.1 Minimum requirement

The power of any UE emission shall not exceed the levels specified in Table 6.10

Table 6.10: Spectrum Emission Mask Requirement

Frequency offset from carrier Δf	Minimum requirement	Measurement bandwidth
2.5 - 3.5 MHz	-35 -15*($\Delta f - 2.5$) dBc	30 kHz *
3.5 - 7.5 MHz	-35 - 1*($\Delta f - 3.5$) dBc	1 MHz **
7.5 - 8.5 MHz	-39 - 10*($\Delta f - 7.5$) dBc	1 MHz **
8.5 - 12.5 MHz	-49 dBc	1 MHz **
* The first and last measurement position with a 30 kHz filter is 2.515 MHz and 3.485 MHz		
** The first and last measurement position with a 1 MHz filter is 4 MHz and 12 MHz. As a general rule, the resolution bandwidth of the measuring equipment should be equal to the measurement bandwidth. To improve measurement accuracy, sensitivity and efficiency, the resolution bandwidth can be different from the measurement bandwidth. When the resolution bandwidth is smaller than the measurement bandwidth, the result should be integrated over the measurement bandwidth.		
The lower limit shall be -50 dBm/3.84 MHz or which ever is higher		

Note *:

1. The first and last measurement position with a 30 kHz filter is 2.515 MHz and 3.485 MHz.
2. The first and last measurement position with a 1 MHz filter is 4 MHz and 12 MHz. As a general rule, the resolution bandwidth of the measuring equipment should be equal to the measurement bandwidth. To improve measurement accuracy, sensitivity and efficiency, the resolution bandwidth can be different from the measurement bandwidth. When the resolution bandwidth is smaller than the measurement bandwidth, the result should be integrated over the measurement bandwidth.
- 3.1. The lower limit shall be -50 dBm/3.84 MHz or which ever is higher.

6.6.2.2 Adjacent Channel Leakage power Ratio (ACLR)

Adjacent Channel Leakage power Ratio (ACLR) is the ratio of the transmitted power to the power measured in an adjacent channel. Both the transmitted power and the adjacent channel power are measured with a filter that has a Root-Raised Cosine (RRC) filter response with roll-off $\alpha = 0.22$ and a bandwidth equal to the chip rate.

6.6.2.2.1 Minimum requirement

If the adjacent channel power is greater than -50dBm then the ACLR shall be higher than the value specified in Table 6.11.

Table 6.11: UE ACLR

Power Class	Adjacent channel relative to UE channel	ACLR limit
3	+ 5 MHz or - 5 MHz	33 dB
3	+ 10 MHz or - 10 MHz	43 dB
4	+ 5 MHz or - 5 MHz	33 dB
4	+ 10 MHz or -10 MHz	43 dB

NOTE 1: The requirement shall still be met in the presence of switching transients.

NOTE 2: The ACLR requirements reflect what can be achieved with present state of the art technology.

NOTE 3: Requirement on the UE shall be reconsidered when the state of the art technology progresses.

6.6.3 Spurious emissions

Spurious emissions are emissions which are caused by unwanted transmitter effects such as harmonics emission, parasitic emission, intermodulation products and frequency conversion products, but exclude out of band emissions.

The frequency boundary and the detailed transitions of the limits between the requirement for out band emissions and spectrum emissions are based on ITU-R Recommendations SM.329.

6.6.3.1 Minimum requirement

These requirements are only applicable for frequencies, which are greater than 12.5 MHz away from the UE centre carrier frequency.

Table 6.12: General spurious emissions requirements

Frequency Bandwidth	Resolution Measurement Bandwidth	Minimum requirement
$9 \text{ kHz} \leq f < 150 \text{ kHz}$	1 kHz	-36 dBm
$150 \text{ kHz} \leq f < 30 \text{ MHz}$	10 kHz	-36 dBm
$30 \text{ MHz} \leq f < 1000 \text{ MHz}$	100 kHz	-36 dBm
$1 \text{ GHz} \leq f < 12.75 \text{ GHz}$	1 MHz	-30 dBm

Frequency Bandwidth	Resolution Bandwidth	Minimum requirement
1893.5 MHz < f < 1919.6 MHz	300 kHz	-41 dBm
925 MHz ≤ f ≤ 935 MHz	100 kHz	-67 dBm *
935 MHz < f ≤ 960 MHz	100 kHz	-79 dBm *
1805 MHz ≤ f ≤ 1880 MHz	100 kHz	-71 dBm *

Table 6.13: Additional spurious emissions requirement

Frequency Band	Frequency Bandwidth	Measurement Bandwidth	Minimum requirement
I	<u>925 MHz ≤ f ≤ 935 MHz</u>	<u>100 kHz</u>	<u>-67 dBm *</u>
	<u>935 MHz < f ≤ 960 MHz</u>	<u>100 kHz</u>	<u>-79 dBm *</u>
	<u>1805 MHz ≤ f ≤ 1880 MHz</u>	<u>100 kHz</u>	<u>-71 dBm *</u>
	<u>1893.5 MHz < f < 1919.6 MHz</u>	<u>300 kHz</u>	<u>-41 dBm</u>
II	=	=	=
III	<u>925 MHz ≤ f ≤ 935 MHz</u>	<u>100 kHz</u>	<u>-67 dBm *</u>
	<u>935 MHz < f ≤ 960 MHz</u>	<u>100 kHz</u>	<u>-79 dBm *</u>
	<u>2110 MHz ≤ f ≤ 2170 MHz</u>		
* <u>The measurements are made on frequencies which are integer multiples of 200 kHz. As exceptions, up to five measurements with a level up to the applicable requirements defined in Table 6.12 are permitted for each UARFCN used in the measurement</u>			

~~NOTE *: The measurements are made on frequencies which are integer multiples of 200 kHz. As exceptions, up to five measurements with a level up to the applicable requirements defined in Table 6.12 are permitted for each UARFCN used in the measurement.~~

6.7 Transmit intermodulation

The transmit intermodulation performance is a measure of the capability of the transmitter to inhibit the generation of signals in its non linear elements caused by presence of the wanted signal and an interfering signal reaching the transmitter via the antenna.

6.7.1 Minimum requirement

User Equipment(s) transmitting in close vicinity of each other can produce intermodulation products, which can fall into the UE, or Node B receive band as an unwanted interfering signal. The UE intermodulation attenuation is defined by the ratio of the output power of the wanted signal to the output power of the intermodulation product when an interfering CW signal is added at a level below the wanted signal. Both the wanted signal power and the IM product power are measured with a filter that has a Root-Raised Cosine (RRC) filter response with roll-off $\alpha = 0.22$ and a bandwidth equal to the chip rate.

The requirement of transmitting intermodulation for a carrier spacing of 5 MHz is prescribed in Table 6.14.

Table 6.14: Transmit Intermodulation

Interference Signal Frequency Offset	5MHz	10MHz
Interference CW Signal Level	-40dBc	
Intermodulation Product	-31dBc	-41dBc

6.8 Transmit modulation

6.8.1 Transmit pulse shape filter

The transmit pulse shaping filter is a root-raised cosine (RRC) with roll-off $\alpha = 0.22$ in the frequency domain. The impulse response of the chip impulse filter $RC_0(t)$ is:

$$RC_0(t) = \frac{\sin\left(\pi \frac{t}{T_c}(1-\alpha)\right) + 4\alpha \frac{t}{T_c} \cos\left(\pi \frac{t}{T_c}(1+\alpha)\right)}{\pi \frac{t}{T_c} \left(1 - \left(4\alpha \frac{t}{T_c}\right)^2\right)}$$

Where the roll-off factor $\alpha = 0.22$ and the chip duration is

$$= \frac{1}{\text{chiprate}} \approx 0.26042 \mu\text{s}$$

6.8.2 Error Vector Magnitude

The Error Vector Magnitude is a measure of the difference between the measured waveform and the theoretical modulated waveform (the error vector). It is the square root of the ratio of the mean error vector power to the mean reference signal power expressed as a %. The measurement interval is one power control group (timeslot).

6.8.2.1 Minimum requirement

The Error Vector Magnitude shall not exceed 17.5 % for the parameters specified in Table 6.15.

Table 6.15: Parameters for Error Vector Magnitude/Peak Code Domain Error

Parameter	Unit	Level
UE Output Power	dBm	≥ -20
Operating conditions		Normal conditions
Power control step size	dB	1

6.8.3 Peak code domain error

The Peak Code Domain Error is computed by projecting power of the error vector (as defined in 6.8.2) onto the code domain at a specific spreading factor. The Code Domain Error for every code in the domain is defined as the ratio of the mean power of the projection onto that code, to the mean power of the composite reference waveform. This ratio is expressed in dB. The Peak Code Domain Error is defined as the maximum value for the Code Domain Error for all codes. The measurement interval is one power control group (timeslot).

The requirement for peak code domain error is only applicable for multi-code transmission.

6.8.3.1 Minimum requirement

The peak code domain error shall not exceed -15 dB at spreading factor 4 for the parameters specified in Table 6.15 . The requirements are defined using the UL reference measurement channel specified in subclause A.2.5.

7 Receiver characteristics

7.1 General

Unless otherwise stated the receiver characteristics are specified at the antenna connector of the UE. For UE(s) with an integral antenna only, a reference antenna with a gain of 0 dBi is assumed. UE with an integral antenna may be taken into account by converting these power levels into field strength requirements, assuming a 0 dBi gain antenna. Receiver characteristics for UE(s) with multiple antennas/antenna connectors are FFS.

The UE antenna performance has a significant impact on system performance, and minimum requirements on the antenna efficiency are therefore intended to be included in future versions of the present document. It is recognised that different requirements and test methods are likely to be required for the different types of UE.

All the parameters in clause 7 are defined using the DL reference measurement channel (12.2 kbps) specified in subclause A.3.1 and unless stated are with DL power control OFF.

7.2 Diversity characteristics

A suitable receiver structure using coherent reception in both channel impulse response estimation and code tracking procedures is assumed. Three forms of diversity are considered to be available in UTRA/FDD.

Table 7.1: Diversity characteristics for UTRA/FDD

Time diversity	Channel coding and interleaving in both up link and down link
Multi-path diversity	Rake receiver or other suitable receiver structure with maximum combining. Additional processing elements can increase the delay-spread performance due to increased capture of signal energy.
Antenna diversity	Antenna diversity with maximum ratio combining in the Node B and optionally in the UE. Possibility for downlink transmit diversity in the Node B.

7.3 Reference sensitivity level

The reference sensitivity $\langle \text{REFSENS} \rangle$ is the minimum receiver input power measured at the antenna port at which the Bit Error Ratio (BER) does not exceed a specific value.

7.3.1 Minimum requirement

The BER shall not exceed 0.001 for the parameters specified in Table 7.2.

Table 7.2: Test parameters for reference sensitivity

<u>Frequency Band</u>	Unit	<u>DPCH Ec</u> <u>$\langle \text{REFSENS} \rangle$ Level</u>	<u>$\langle \text{REF}_{\text{or}} \rangle$</u>
<u>I</u>	dBm/3.84 MHz	-117	-106.7
<u>II</u>	dBm/3.84 MHz	<u>-115</u>	<u>-104.7</u>
<u>III</u>	dBm/3.84 MHz	<u>-114</u>	<u>-103.7</u>
<u>1. For Power class 3 this shall be at the maximum output power</u> <u>2. For Power class 4 this shall be at the maximum output power</u>			

7.4 Maximum input level

This is defined as the maximum receiver input power at the UE antenna port, which does not degrade the specified BER performance.

7.4.1 Minimum requirement

The BER shall not exceed 0.001 for the parameters specified in Table 7.3.

Table 7.3: Maximum input level

Parameter	Unit	Level
$\frac{DPCH_Ec}{I_{or}}$	dB	-19
\hat{I}_{or}	dBm/3.84 MHz	-25
<ol style="list-style-type: none"> 1. For Power class 3 the average power shall be +20 dBm 2. For Power class 4 the average power shall be +18 dBm 		

NOTE: Since the spreading factor is large ($10\log(SF)=21\text{dB}$), the majority of the total input signal consists of the OCNS interference. The structure of OCNS signal is defined in Annex C.3.2.

7.5 Adjacent Channel Selectivity (ACS)

Adjacent Channel Selectivity (ACS) is a measure of a receiver's ability to receive a W-CDMA signal at its assigned channel frequency in the presence of an adjacent channel signal at a given frequency offset from the centre frequency of ratio of the receive filter attenuation on the assigned channel frequency to the receive filter attenuation on the adjacent channel(s).

7.5.1 Minimum requirement

The ACS shall be better than the value indicated in Table 7.4 for the test parameters specified in Table 7.5 where the BER shall not exceed 0.001.

Table 7.4: Adjacent Channel Selectivity

Power Class	Unit	ACS
3	dB	33
4	dB	33

Table 7.5: Test parameters for Adjacent Channel Selectivity

Parameter	Unit	Level
DPCH_Ec	dBm/3.84 MHz	-103
\hat{I}_{or}	dBm/3.84 MHz	-92.7
I_{oac} (modulated)	dBm/3.84 MHz	-52
F_{uw} (offset)	MHz	+5 or -5
<ol style="list-style-type: none"> 1. For Power class 3 the average power shall be +20 dBm 2. For Power class 4 the average power shall be +18 dBm 		

Note The I_{oac} (modulated) signal consist of common channels needed for tests and 16 dedicated data channel. The channelization codes for data channels are chosen optimally to reduce peak to average ratio (PAR). All dedicated channels user data is uncorrelated to each other.

7.6 Blocking characteristics

The blocking characteristic is a measure of the receiver's ability to receive a wanted signal at its assigned channel frequency in the presence of an unwanted interferer on frequencies other than those of the spurious response or the adjacent channels, without this unwanted input signal causing a degradation of the performance of the receiver beyond a specified limit. The blocking performance shall apply at all frequencies except those at which a spurious response occur.

7.6.1 Minimum requirement (In-band blocking)

The BER shall not exceed 0.001 for the parameters specified in Table 7.6 ~~and Table 7.7. For Table 7.7 up to (24) exceptions are allowed for spurious response frequencies in each assigned frequency channel when measured using a 1 MHz step size.~~

Table 7.6: In-band blocking

Parameter	Unit	Offset	Offset
DPCH_Ec	dBm/3.84 MHz	−<REFSENS>+3 dB 144	−<REFSENS>+3 dB 144
\hat{I}_{or}	dBm/3.84 MHz	<REF\hat{I}_{or}> + 3 dB- 103.7	<REF\hat{I}_{or}> + 3 dB- 103.7
I _{blocking} (modulated)	dBm/3.84 MHz	-56	-44
F _{uw} (offset)	MHz	+10 or −10	+15 or −15
<ol style="list-style-type: none"> 1. For Power class 3 the average power shall be +20 dBm 2. For Power class 4 the average power shall be +18 dBm 			

Note: I_{blocking} (modulated) consist of common channels and 16 dedicated data channel. The channelization codes for data channels are chosen optimally to reduce peak to average ratio (PAR). All dedicated channels user data is uncorrelated to each other.

7.6.2 Minimum requirement (Out of-band blocking)

The BER shall not exceed 0.001 for the parameters specified in Table 7.7. For Table 7.7 up to 24 exceptions are allowed for spurious response frequencies in each assigned frequency channel when measured using a 1 MHz step size. For these exceptions the requirements of clause 7.7 Spurious response are applicable

Table 7.7: Out of band blocking

Parameter	Unit	Band 1	Band 2	Band 3
DPCH_Ec	dBm/3.84 MHz	<REFSENS>+3 dB-144	<REFSENS>+3 dB-144	<REFSENS>+3 dB-144
\hat{I}_{or}	dBm/3.84 MHz	<REF \hat{I}_{or} > + 3 dB-103.7	<REF \hat{I}_{or} > + 3 dB- 103.7	<REF \hat{I}_{or} > + 3 dB-103.7
I _{blocking} (CW)	dBm	-44	-30	-15
F_{uw} For operation in frequency bands as defined in subclause 5.2(a)I	MHz	2050<f <2095 2185<f <2230	2025 <f <2050 2230 <f <2255	1< f <2025 2255<f<12750
F_{uw} For operation in frequency bands as defined in subclause 5.2(b)II	MHz	1870<f <1915 2005<f <2050	1845 <f <1870 2050 <f <2075	1< f <1845 2075<f<12750
III	MHz	1745-<f <-1790 1895<f <1940	1720 <f < 1745 1940<f < 1965	1< f <1720 1965<f<12750
I	For 2095<f<2110 MHz and 2170<f<2185 MHz, the appropriate in-band blocking or adjacent channel selectivity in subclause 7.5.1 and subclause 7.6.1 shall be applied.			
II	For 1915<f<1930 MHz and 1990<f<2005 MHz, the appropriate in-band blocking or adjacent channel selectivity in subclause 7.5.1 and subclause 7.6.2 shall be applied			
III	For 1790<f<1805 MHz and 1880<f<1895 MHz, the appropriate in-band blocking or adjacent channel selectivity in subclause 7.5.1 and subclause 7.6.2 shall be applied.			
1. For Power class 3 the average power shall be +20 dBm 2. For Power class 4 the average power shall be +18 dBm				

Note:

~~2. For operation in bands referenced in 5.2(b), 1915<f<1930 MHz and 1990<f<2005 MHz, the appropriate in band blocking or adjacent channel selectivity in subclause 7.5.1 shall be applied.~~

7.6.3 Minimum requirement (Narrow band blocking)

The BER shall not exceed 0.001 for the parameters specified in Table 7.x.x . This requirement is measure of a receiver's ability to receive a W-CDMA signal at its assigned channel frequency in the presence of an unwanted narrow band interferer at a frequency, which is less than the nominal channel spacing

Table 7.x.x: Narrow band blocking characteristics

Parameter	Unit	Band II	Band III
DPCH_Ec	dBm/3.84 MHz		
\hat{I}_{or}	dBm/3.84 MHz		
	dBm		
F_{uw} (offset)	MHz		

7.7 Spurious response

Spurious response is a measure of the receiver's ability to receive a wanted signal on its assigned channel frequency without exceeding a given degradation due to the presence of an unwanted CW interfering signal at any other frequency at which a response is obtained i.e. for which [the-subclause 7.6.2 out of band](#) blocking limit is not met.

7.7.1 Minimum requirement

The BER shall not exceed 0.001 for the parameters specified in Table 7.8.

Table 7.8: Spurious Response

Parameter	Unit	Level
DPCH_Ec	dBm/3.84 MHz	<REFSENS>+3 dB-114
\hat{I}_{or}	dBm/3.84 MHz	<REF \hat{I}_{or} > + 3 dB-103.7
$I_{blocking}$ (CW)	dBm	-44
F_{uw}	MHz	Spurious response frequencies
1. For Power class 3 the average power shall be +20 dBm 2. For Power class 4 the average output power shall be +18 dBm		

7.8 Intermodulation characteristics

Third and higher order mixing of the two interfering RF signals can produce an interfering signal in the band of the desired channel. Intermodulation response rejection is a measure of the capability of the receiver to receiver a wanted signal on its assigned channel frequency in the presence of two or more interfering signals which have a specific frequency relationship to the wanted signal.

7.8.1 Minimum requirement

The BER shall not exceed 0.001 for the parameters specified in Table 7.9.

Table 7.9: Receive intermodulation characteristics

Parameter	Unit	Level	
DPCH_Ec	dBm/3.84 MHz	<REFSENS>+3 dB-114	
\hat{I}_{or}	dBm/3.84 MHz	<REF \hat{I}_{or} > + 3 dB-103.7	
I_{ouw1} (CW)	dBm	-46	
I_{ouw2} (modulated)	dBm/3.84 MHz	-46	
F_{uw1} (offset)	MHz	10	-10
F_{uw2} (offset)	MHz	20	-20
1. For Power class 3 the average power shall be +20 dBm 2. For Power class 4 the average power shall be +18 dBm			

Note: I_{ouw2} (modulated) consist of common channels and 16 dedicated data channel. The channelization codes for data channels are chosen optimally to reduce peak to average ratio (PAR). All dedicated channels user data is uncorrelated to each other.

7.9 Spurious emissions

The spurious emissions power is the power of emissions generated or amplified in a receiver that appear at the UE antenna connector.

7.9.1 Minimum requirement

The power of any narrow band CW spurious emission shall not exceed the maximum level specified in Table 7.10 and Table 7.11

Table 7.10: General receiver spurious emission requirements

Frequency Band	Measurement Bandwidth	Maximum level	Note
$1\text{kHz} \leq f < 1\text{GHz}$	100 kHz	-57 dBm	
$1\text{GHz} \leq f \leq 12.75\text{GHz}$	1 MHz	-47 dBm	

Table 7.11: Additional receiver spurious emission requirements

<u>Band</u>	Frequency Band	Measurement Bandwidth	Maximum level	Note
<u>I</u>	$1920\text{MHz} \leq f \leq 1980\text{MHz}$	3.84 MHz	-60 dBm	Mobile-UE transmit band in URA_PCH, Cell_PCH and idle state
	$2110\text{MHz} \leq f \leq 2170\text{MHz}$	3.84 MHz	-60 dBm	Mobile-UE receive band
<u>II</u>	<u>$1850\text{MHz} \leq f \leq 1910\text{MHz}$</u>	<u>3.84 MHz</u>	<u>-60 dBm</u>	<u>UE transmit band in URA_PCH, Cell_PCH and idle state</u>
	<u>$1930\text{MHz} \leq f \leq 1990\text{MHz}$</u>	<u>3.84 MHz</u>	<u>-60 dBm</u>	<u>UE receive band</u>
<u>III</u>	<u>$1710\text{MHz} \leq f \leq 1785\text{MHz}$</u>	<u>3.84 MHz</u>	<u>-60 dBm</u>	<u>UE transmit band in URA_PCH, Cell_PCH and idle state</u>
	<u>$1805\text{MHz} \leq f \leq 1880\text{MHz}$</u>	<u>3.84 MHz</u>	<u>-60 dBm</u>	<u>UE receive band</u>

CHANGE REQUEST

⌘ **25.104 CR 62** ⌘ rev **-** ⌘ Current version: **3.5.0** ⌘

For **HELP** on using this form, see bottom of this page or look at the pop-up text over the ⌘ symbols.

Proposed change affects: ⌘ (U)SIM ME/UE Radio Access Network Core Network

Title:	⌘ TS25.104 REL 4 – Document structure		
Source:	⌘ RAN WG4		
Work item code:	⌘ RInImp-UMTS18	Date:	⌘ 22-02-01
Category:	⌘ B	Release:	⌘ REL-4
	Use <u>one</u> of the following categories: F (essential correction) A (corresponds to a correction in an earlier release) B (Addition of feature), C (Functional modification of feature) D (Editorial modification) Detailed explanations of the above categories can be found in 3GPP TR 21.900.		Use <u>one</u> of the following releases: 2 (GSM Phase 2) R96 (Release 1996) R97 (Release 1997) R98 (Release 1998) R99 (Release 1999) REL-4 (Release 4) REL-5 (Release 5)

Reason for change:	⌘ Addition of expansion bands to BS requirement which include UMTS-1800
Summary of change:	⌘ Re-structure of document, revised performance requirement for PCS and DCS band.
Consequences if not approved:	⌘ Specification required for implementation

Clauses affected:	⌘ Section 5, 6.6.3, 7		
Other specs affected:	⌘ <input type="checkbox"/> Other core specifications ⌘ <input checked="" type="checkbox"/> Test specifications ⌘ <input type="checkbox"/> O&M Specifications	⌘ TS25.141	
Other comments:	⌘		

How to create CRs using this form:

Comprehensive information and tips about how to create CRs can be found at: http://www.3gpp.org/3G_Specs/CRs.htm. Below is a brief summary:

- 1) Fill out the above form. The symbols above marked ⌘ contain pop-up help information about the field that they are closest to.
- 2) Obtain the latest version for the release of the specification to which the change is proposed. Use the MS Word "revision marks" feature (also known as "track changes") when making the changes. All 3GPP specifications can be downloaded from the 3GPP server under <ftp://www.3gpp.org/specs/> For the latest version, look for the directory name with the latest date e.g. 2000-09 contains the specifications resulting from the September 2000 TSG meetings.
- 3) With "track changes" disabled, paste the entire CR form (use CTRL-A to select it) into the specification just in front of the clause containing the first piece of changed text. Delete those parts of the specification which are not relevant to the change request.

5 Frequency bands and channel arrangement

5.1 General

The information presented in this section is based on a chip rate of 3.84 Mcps.

NOTE 1: Other chip rates may be considered in future releases.

5.2 Frequency bands

UTRA/FDD is designed to operate in ~~either of~~ the following paired bands;

~~(a) 1920 – 1980MHz: Up link (Mobile transmit, base receive)
2110 – 2170MHz: Down link (Base transmit, mobile receive)~~

~~(b) 1850 – 1910MHz: Up link (Mobile transmit, base receive)
1930 – 1990MHz: Down link (Base transmit, mobile receive)
(Note 1)~~

~~NOTE 1: Used in Region 2. Additional allocations in ITU region 2 are FFS.~~

<u>Frequency Band</u>	<u>UL Frequencies</u> <u>UE transmit, Node B receive</u>	<u>DL frequencies</u> <u>UE receive, Node B transmit</u>
<u>I</u>	<u>1920 – 1980 MHz</u>	<u>2110 – 2170 MHz</u>
<u>II</u>	<u>1850 – 1910 MHz</u>	<u>1930 – 1990 MHz</u>
<u>III</u>	<u>1710-1785 MHz</u>	<u>1805-1880 MHz</u>

~~NOTE 2: Deployment in other frequency bands is not precluded.~~

5.3 Tx-Rx frequency separation

(a) UTRA/FDD is designed to operate with the following TX-RX frequency separation

<u>Frequency Band</u>	<u>TX-RX frequency separation</u>		
	<u>Mandatory value supported by all UEs</u>	<u>Minimum value</u>	<u>Maximum value</u>
<u>I</u>	<u>190 MHz</u>	<u>134.8 MHz</u>	<u>245.2 MHz</u>
<u>II</u>	<u>80 MHz.</u>	<u>24.8 MHz</u>	<u>135.2 MHz</u>
<u>III</u>	<u>95 MHz.</u>	<u>24.8 MHz</u>	<u>165.2 MHz</u>

~~(a) The minimum transmit to receive frequency separation is 134.8 MHz and the maximum value is 245.2 MHz and all UE(s) shall support a TX – RX frequency separation of 190 MHz when operating in the paired band defined in sub-clause 5.2(a).~~

(b) UTRA/FDD can support both fixed and variable transmit to receive frequency separation.

~~(c) When operating in the paired band defined in sub-clause 5.2(b), all UE(s) shall support a TX-RX frequency separation of 80 MHz.~~

(c) The use of other transmit to receive frequency separations in existing or other frequency bands shall not be precluded.

5.4 Channel arrangement

5.4.1 Channel spacing

The nominal channel spacing is 5 MHz, but this can be adjusted to optimize performance in a particular deployment scenario.

5.4.2 Channel raster

The channel raster is 200 kHz, which means that the center frequency must be an integer multiple of 200 kHz.

5.4.3 Channel number

The carrier frequency is designated by the UTRA Absolute Radio Frequency Channel Number (UARFCN). The value of the UARFCN in the IMT2000 band is defined as follows:

Table 5.1: UTRA Absolute Radio Frequency Channel Number

Uplink	$N_u = 5 * F_{\text{uplink}}$	$0.0 \text{ MHz} \leq F_{\text{uplink}} \leq 3276.6 \text{ MHz}$ where F_{uplink} is the uplink frequency in MHz
Downlink	$N_d = 5 * F_{\text{downlink}}$	$0.0 \text{ MHz} \leq F_{\text{downlink}} \leq 3276.6 \text{ MHz}$ where F_{downlink} is the downlink frequency in MHz

6 Transmitter characteristics

6.1 General

Unless otherwise stated, the transmitter characteristics are specified at the BS antenna connector (test port A) with a full complement of transceivers for the configuration in normal operating conditions. If any external apparatus such as a TX amplifier, a diplexer, a filter or the combination of such devices is used, requirements apply at the far end antenna connector (port B).

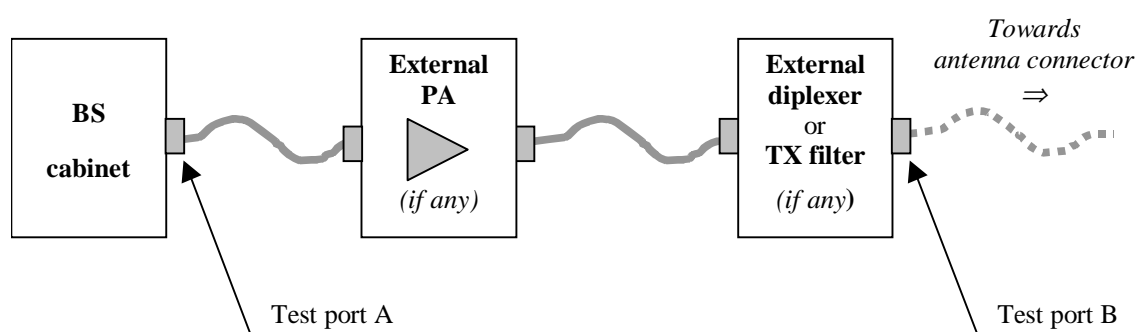

Figure 6.1: Transmitter test ports

6.6.3 Spurious emissions

Spurious emissions are emissions which are caused by unwanted transmitter effects such as harmonics emission, parasitic emission, intermodulation products and frequency conversion products, but exclude out of band emissions. This is measured at the base station RF output port.

Unless otherwise stated, all requirements are measured as mean power.

6.6.3.1 Mandatory Requirements

The requirements of either subclause 6.6.3.1.1 or subclause 6.6.3.1.2 shall apply whatever the type of transmitter considered (single carrier or multiple-carrier). It applies for all transmission modes foreseen by the manufacturer's specification.

Either requirement applies at frequencies within the specified frequency ranges that are more than 12.5MHz below the first carrier frequency used or more than 12.5MHz above the last carrier frequency used.

6.6.3.1.1 Spurious emissions (Category A)

The following requirements shall be met in cases where Category A limits for spurious emissions, as defined in ITU-R Recommendation SM.329-7 [1], are applied.

6.6.3.1.1.1 Minimum Requirement

The power of any spurious emission shall not exceed:

Table 6.8: BS Mandatory spurious emissions limits, Category A

Band	Maximum level	Measurement Bandwidth	Note
9kHz - 150kHz	-13 dBm	1 kHz	Bandwidth as in ITU-R SM.329-7, s4.1
150kHz - 30MHz		10 kHz	Bandwidth as in ITU-R SM.329-7, s4.1
30MHz - 1GHz		100 kHz	Bandwidth as in ITU-R SM.329-7, s4.1
1GHz - 12.75 GHz		1 MHz	Upper frequency as in ITU-R SM.329-7, s2.6

6.6.3.1.2 Spurious emissions (Category B)

The following requirements shall be met in cases where Category B limits for spurious emissions, as defined in ITU-R Recommendation SM.329-7 [1], are applied.

6.6.3.1.2.1 Minimum Requirement

The power of any spurious emission shall not exceed:

Table 6.9: BS Mandatory spurious emissions limits, Category B

<u>Frequency Band</u>	<u>Band</u>	<u>Maximum Level</u>	<u>Measurement Bandwidth</u>	<u>Note</u>
I	<u>9kHz ↔ 150kHz</u>	<u>-36 dBm</u>	<u>1 kHz</u>	<u>Bandwidth as in ITU-R SM.329-7, s4.1</u>
	<u>150kHz ↔ 30MHz</u>	<u>- 36 dBm</u>	<u>10 kHz</u>	<u>Bandwidth as in ITU-R SM.329-7, s4.1</u>
	<u>30MHz ↔ 1GHz</u>	<u>-36 dBm</u>	<u>100 kHz</u>	<u>Bandwidth as in ITU-R SM.329-7, s4.1</u>
	<u>1GHz</u> ↔ <u>Fc1 - 60 MHz or 2100 MHz</u> <u>whichever is the higher</u>	<u>-30 dBm</u>	<u>1 MHz</u>	<u>Bandwidth as in ITU-R SM.329-7, s4.1</u>
	<u>Fc1 - 60 MHz or 2100 MHz</u> <u>whichever is the higher</u> ↔ <u>Fc1 - 50 MHz or 2100 MHz</u> <u>whichever is the higher</u>	<u>-25 dBm</u>	<u>1 MHz</u>	<u>Specification in accordance with ITU-R SM.329-7, s4.1</u>
	<u>Fc1 - 50 MHz or 2100 MHz</u> <u>whichever is the higher</u> ↔ <u>Fc2 + 50 MHz or 2180 MHz</u> <u>whichever is the lower</u>	<u>-15 dBm</u>	<u>1 MHz</u>	<u>Specification in accordance with ITU-R SM.329-7, s4.1</u>
	<u>Fc2 + 50 MHz or 2180 MHz</u> <u>whichever is the lower</u> ↔ <u>Fc2 + 60 MHz or 2180 MHz</u> <u>whichever is the lower</u>	<u>-25 dBm</u>	<u>1 MHz</u>	<u>Specification in accordance with ITU-R SM.329-7, s4.1</u>
	<u>Fc2 + 60 MHz or 2180 MHz</u> <u>whichever is the lower</u> ↔ <u>12.75 GHz</u>	<u>-30 dBm</u>	<u>1 MHz</u>	<u>Bandwidth as in ITU-R SM.329-7, s4.1. Upper frequency as in ITU-R SM.329-7, s2.6</u>
II	<u>9kHz ↔ 150kHz</u>	<u>-36 dBm</u>	<u>1 kHz</u>	<u>Bandwidth as in ITU-R SM.329-7, s4.1</u>
	<u>150kHz ↔ 30MHz</u>	<u>- 36 dBm</u>	<u>10 kHz</u>	<u>Bandwidth as in ITU-R SM.329-7, s4.1</u>
	<u>30MHz ↔ 1GHz</u>	<u>-36 dBm</u>	<u>100 kHz</u>	<u>Bandwidth as in ITU-R SM.329-7, s4.1</u>
	<u>1GHz</u> ↔ <u>Fc1 - 60 MHz or 1920 MHz</u> <u>whichever is the higher</u>	<u>-30 dBm</u>	<u>1 MHz</u>	<u>Bandwidth as in ITU-R SM.329-7, s4.1</u>
	<u>Fc1 - 60 MHz or 1920 MHz</u> <u>whichever is the higher</u> ↔ <u>Fc1 - 50 MHz or 1920 MHz</u> <u>whichever is the higher</u>	<u>-25 dBm</u>	<u>1 MHz</u>	<u>Specification in accordance with ITU-R SM.329-7, s4.1</u>
	<u>Fc1 - 50 MHz or 1920 MHz</u> <u>whichever is the higher</u> ↔ <u>Fc2 + 50 MHz or 1890 MHz</u> <u>whichever is the lower</u>	<u>-15 dBm</u>	<u>1 MHz</u>	<u>Specification in accordance with ITU-R SM.329-7, s4.1</u>
	<u>Fc2 + 50 MHz or 2000 MHz</u> <u>whichever is the lower</u> ↔ <u>Fc2 + 60 MHz or 2000 MHz</u> <u>whichever is the lower</u>	<u>-25 dBm</u>	<u>1 MHz</u>	<u>Specification in accordance with ITU-R SM.329-7, s4.1</u>

	<u>Fc2 + 60 MHz or 2000 MHz whichever is the lower</u> ↔ <u>12.75 GHz</u>	<u>-30 dBm</u>	<u>1 MHz</u>	<u>Bandwidth as in ITU-R SM.329-7, s4.1. Upper frequency as in ITU-R SM.329-7, s2.6</u>
III	<u>9kHz ↔ 150kHz</u>	<u>-36 dBm</u>	<u>1 kHz</u>	<u>Bandwidth as in ITU-R SM.329-7, s4.1</u>
	<u>150kHz ↔ 30MHz</u>	<u>-36 dBm</u>	<u>10 kHz</u>	<u>Bandwidth as in ITU-R SM.329-7, s4.1</u>
	<u>30MHz ↔ 1GHz</u>	<u>-36 dBm</u>	<u>100 kHz</u>	<u>Bandwidth as in ITU-R SM.329-7, s4.1</u>
	<u>1GHz</u> ↔ <u>Fc1 - 60 MHz or 1795 MHz whichever is the higher</u>	<u>-30 dBm</u>	<u>1 MHz</u>	<u>Bandwidth as in ITU-R SM.329-7, s4.1</u>
	<u>Fc1 - 60 MHz or 1795 MHz whichever is the higher</u> ↔ <u>Fc1 - 50 MHz or 1795 MHz whichever is the higher</u>	<u>-25 dBm</u>	<u>1 MHz</u>	<u>Specification in accordance with ITU-R SM.329-7, s4.1</u>
	<u>Fc1 - 50 MHz or 1795 MHz whichever is the higher</u> ↔ <u>Fc2 + 50 MHz or 1890 MHz whichever is the lower</u>	<u>-15 dBm</u>	<u>1 MHz</u>	<u>Specification in accordance with ITU-R SM.329-7, s4.1</u>
	<u>Fc2 + 50 MHz or 1890 MHz whichever is the lower</u> ↔ <u>Fc2 + 60 MHz or 1890 MHz whichever is the lower</u>	<u>-25 dBm</u>	<u>1 MHz</u>	<u>Specification in accordance with ITU-R SM.329-7, s4.1</u>
	<u>Fc2 + 60 MHz or 1890 MHz whichever is the lower</u> ↔ <u>12.75 GHz</u>	<u>-30 dBm</u>	<u>1 MHz</u>	<u>Bandwidth as in ITU-R SM.329-7, s4.1. Upper frequency as in ITU-R SM.329-7, s2.6</u>

Table 6.9: BS Mandatory spurious emissions limits, Category B

Band	Maximum Level	Measurement Bandwidth	Note
9kHz ↔ 150kHz	-36 dBm	1 kHz	Bandwidth as in ITU-R SM.329-7, s4.1
150kHz ↔ 30MHz	-36 dBm	10 kHz	Bandwidth as in ITU-R SM.329-7, s4.1
30MHz ↔ 1GHz	-36 dBm	100 kHz	Bandwidth as in ITU-R SM.329-7, s4.1
1GHz ↔ Fc1 - 60 MHz or 2100 MHz whichever is the higher	-30 dBm	1 MHz	Bandwidth as in ITU-R SM.329-7, s4.1
Fc1 - 60 MHz or 2100 MHz whichever is the higher ↔ Fc1 - 50 MHz or 2100 MHz whichever is the higher	-25 dBm	1 MHz	Specification in accordance with ITU-R SM.329-7, s4.1
Fc1 - 50 MHz or 2100 MHz whichever is the higher ↔ Fc2 + 50 MHz or 2180 MHz whichever is the lower	-15 dBm	1 MHz	Specification in accordance with ITU-R SM.329-7, s4.1

$F_{c2} + 50 \text{ MHz or } 2180 \text{ MHz}$ <i>whichever is the lower</i> \leftrightarrow $F_{c2} + 60 \text{ MHz or } 2180 \text{ MHz}$ <i>whichever is the lower</i>	-25 dBm	1 MHz	Specification in accordance with ITU-R SM.329-7, s4.1
$F_{c2} + 60 \text{ MHz or } 2180 \text{ MHz}$ <i>whichever is the lower</i> \leftrightarrow 12.75 GHz	-30 dBm	1 MHz	Bandwidth as in ITU-R SM.329-7, s4.1. Upper frequency as in ITU-R SM.329-7, s2.6

Fc1: Center frequency of emission of the first carrier transmitted by the BS.

Fc2: Center frequency of emission of the last carrier transmitted by the BS.

6.6.3.2. Protection of the BS receiver

This requirement may be applied in order to prevent the receiver of the BS being desensitised by emissions from the BS transmitter, which are coupled between the antennas of the BS. This is measured at the transmit antenna port.

6.6.3.2.1 Minimum Requirement

The power of any spurious emission shall not exceed:

Table 6.10: BS Spurious emissions limits for protection of the BS receiver

Band	Maximum Level	Measurement Bandwidth	Note
1920 - 1980MHz For operation in Frequency Band I	-96 dBm	100 kHz	
1850-1910 MHz For operation in Frequency Band II	-96dBm	100kHz	
1710-1785 MHz For operation in Frequency Band III	-96 dBm	100kHz	

Table 6.10: BS Spurious emissions limits for protection of the BS receiver

Band	Maximum Level	Measurement Bandwidth	Note
1920 - 1980MHz For operation in Frequency Bands defined in sub-clause 5.2(a)	-96 dBm	100 kHz	
1850-1910 MHz For operation in Frequency Bands defined in sub-clause 5.2(b)	-96 dBm	100kHz	

6.6.3.3 Co-existence with GSM 900

6.6.3.3.1 Operation in the same geographic area

This requirement may be applied for the protection of GSM 900 MS in geographic areas in which both GSM 900 and UTRA are deployed.

6.6.3.3.1.1 Minimum Requirement

The power of any spurious emission shall not exceed:

Table 6.11: BS Spurious emissions limits for BS in geographic coverage area of GSM 900 MS receiver

Band	Maximum Level	Measurement Bandwidth	Note
921 - 960 MHz	-57 dBm	100 kHz	

6.6.3.3.2 Co-located base stations

This requirement may be applied for the protection of GSM 900 BTS receivers when GSM 900 BTS and UTRA BS are co-located.

6.6.3.3.2.1 Minimum Requirement

The power of any spurious emission shall not exceed:

Table 6.12: BS Spurious emissions limits for protection of the GSM 900 BTS receiver

Band	Maximum Level	Measurement Bandwidth	Note
876-915 MHz	-98 dBm	100 kHz	

6.6.3.4 Co-existence with DCS 1800

6.6.3.4.1 Operation in the same geographic area

This requirement may be applied for the protection of DCS 1800 MS in geographic areas in which both DCS 1800 and UTRA are deployed.

6.6.3.4.1.1 Minimum Requirement

The power of any spurious emission shall not exceed:

Table 6.13: BS Spurious emissions limits for BS in geographic coverage area of DCS 1800 MS receiver

Band	Maximum Level	Measurement Bandwidth	Note
1805 - 1880 MHz	-47 dBm	100 kHz	

6.6.3.4.2 Co-located base stations

This requirement may be applied for the protection of DCS 1800 BTS receivers when DCS 1800 BTS and UTRA BS are co-located.

6.6.3.4.2.1 Minimum Requirement

The power of any spurious emission shall not exceed:

Table 6.14: BS Spurious emissions limits for BS co-located with DCS 1800 BTS

Band	Maximum Level	Measurement Bandwidth	Note
1710 - 1785 MHz	-98 dBm	100 kHz	

6.6.3.5 Co-existence with UTRA in frequency band I

6.6.3.5.1 Operation in the same geographic area

This requirement may be applied for the protection of UTRA UE operating in frequency band I in geographic areas in which both UTRA in frequency band I and UTRA FDD operating in other frequency band(s) are deployed. This requirement is not applicable for BS operating in frequency band I.

6.6.3.5.1.1 Minimum Requirement

The power of any spurious emission shall not exceed:

Table 6.14: BS Spurious emissions limits for BS in geographic coverage area of UTRA UE receiver operating in frequency band I

Band	Maximum Level	Measurement Bandwidth	Note
2110 - 2170 MHz	-62 dBm	100 kHz	

6.6.3.5.2 Co-located base stations

This requirement may be applied for the protection of UTRA BS receivers operating in frequency band I when UTRA BS operating in frequency band I and UTRA FDD BS operating in other frequency band(s) are co-located. This requirement is not applicable for BS operating in frequency band I.

6.6.3.5.2.1 Minimum Requirement

The power of any spurious emission shall not exceed:

Table 6.15: BS Spurious emissions limits for BS co-located with UTRA BS operating in frequency band I

Band	Maximum Level	Measurement Bandwidth	Note
1920 - 1980 MHz	-96 dBm	100 kHz	

6.6.3.6 Co-existence with UTRA in frequency band III

6.6.3.6.1 Operation in the same geographic area

This requirement may be applied for the protection of UTRA UE operating in frequency band III in geographic areas in which both UTRA in frequency band III and UTRA FDD operating in other frequency band(s) are deployed. This requirement is not applicable for BS operating in frequency band III.

6.6.3.6.1.1 Minimum Requirement

The power of any spurious emission shall not exceed:

Table 6.16: BS Spurious emissions limits for BS in geographic coverage area of UTRA UE receiver operating in frequency band III

<u>Band</u>	<u>Maximum Level</u>	<u>Measurement Bandwidth</u>	<u>Note</u>
1805 – 1880 MHz	-62 dBm	100 kHz	

6.6.3.6.2 Co-located base stations

This requirement may be applied for the protection of UTRA BS receivers operating in frequency band III when UTRA BS operating in frequency band III and UTRA FDD BS operating in other frequency band(s) are co-located. This requirement is not applicable for BS operating in frequency band III.

6.6.3.6.2.1 Minimum Requirement

The power of any spurious emission shall not exceed:

Table 6.17: BS Spurious emissions limits for BS co-located with UTRA BS operating in frequency band III

<u>Band</u>	<u>Maximum Level</u>	<u>Measurement Bandwidth</u>	<u>Note</u>
1805 – 1880 MHz	-96 dBm	100 kHz	

6.6.3.75 Co-existence with PHS

This requirement may be applied for the protection of PHS in geographic areas in which both PHS and UTRA are deployed.

6.6.3.75.1 Minimum Requirement

The power of any spurious emission shall not exceed:

Table 6.1845: BS Spurious emissions limits for BS in geographic coverage area of PHS

<u>Band</u>	<u>Maximum Level</u>	<u>Measurement Bandwidth</u>	<u>Note</u>
1893.5 - 1919.6 MHz	-41 dBm	300 kHz	

6.6.3.86 Co-existence with services in adjacent frequency bands

This requirement may be applied for the protection in bands adjacent to 2110-2170 MHz, as defined in sub-clause 5.2(a) and 1930-1990 MHz, as defined in sub-clause 5.2(b) in geographic areas in which both an adjacent band service and UTRA are deployed.

6.6.3.86.1 Minimum requirement

The power of any spurious emission shall not exceed:

Table 6.19: BS spurious emissions limits for protection of adjacent band services

Frequency Band	Band (f)	Maximum Level	Measurement Bandwidth	Note
I	2100-2105 MHz	$-30 + 3.4 \cdot (f - 2100 \text{ MHz})$ dBm	1 MHz	
	2175-2180 MHz	$-30 + 3.4 \cdot (2180 \text{ MHz} - f)$ dBm	1 MHz	
II	1920-1925 MHz	$-30 + 3.4 \cdot (f - 1920 \text{ MHz})$ dBm	1 MHz	
	1995-2000 MHz	$-30 + 3.4 \cdot (2000 \text{ MHz} - f)$ dBm	1 MHz	
III	1795-1800 MHz	$-30 + 3.4 \cdot (f - 1795 \text{ MHz})$ dBm	1MHz	
	1885-1890 MHz	$-30 + 3.4 \cdot (1890 \text{ MHz} - f)$ dBm	1MHz	

Table 6.16: BS spurious emissions limits for protection of adjacent band services

Band (f)	Maximum Level	Measurement Bandwidth	Note
2100-2105 MHz For operation in frequency bands as defined in sub-clause 5.2(a)	$-30 + 3.4 \cdot (f - 2100 \text{ MHz})$ dBm	1 MHz	
2175-2180 MHz For operation in frequency bands as defined in sub-clause 5.2(a)	$-30 + 3.4 \cdot (2180 \text{ MHz} - f)$ dBm	1 MHz	
1920-1925 MHz For operation in frequency bands as defined in sub-clause 5.2(b)	$-30 + 3.4 \cdot (f - 1920 \text{ MHz})$ dBm	1 MHz	
1995-2000 MHz For operation in frequency bands as defined in sub-clause 5.2(b)	$-30 + 3.4 \cdot (2000 \text{ MHz} - f)$ dBm	1 MHz	

6.6.3.97 Co-existence with UTRA-TDD

6.6.3.97.1 Operation in the same geographic area

This requirement may be applied to geographic areas in which both UTRA-TDD and UTRA-FDD are deployed.

6.6.3.97.1.1 Minimum Requirement

The power of any spurious emission shall not exceed:

Table 6.2047: BS Spurious emissions limits for BS in geographic coverage area of UTRA-TDD

Band	Maximum Level	Measurement Bandwidth	Note
1900 - 1920 MHz	-52 dBm	1 MHz	
2010 - 2025 MHz	-52 dBm	1 MHz	

6.6.3.97.2 Co-located base stations

This requirement may be applied for the protection of UTRA-TDD BS receivers when UTRA-TDD BS and UTRA FDD BS are co-located.

6.6.3.97.2.1 Minimum Requirement

The power of any spurious emission shall not exceed:

Table 6.2148: BS Spurious emissions limits for BS co-located with UTRA-TDD

Band	Maximum Level	Measurement Bandwidth	Note
1900 - 1920 MHz	-86 dBm	1 MHz	
2010 - 2025 MHz	-86 dBm	1 MHz	

7 Receiver characteristics

7.1 General

The requirements in Section 7 assume that the receiver is not equipped with diversity. For receivers with diversity, the requirements apply to each antenna connector separately, with the other one(s) terminated or disabled. The requirements are otherwise unchanged.

Unless otherwise stated, the receiver characteristics are specified at the BS antenna connector (test port A) with a full complement of transceivers for the configuration in normal operating conditions. If any external apparatus such as a RX amplifier, a diplexer, a filter or the combination of such devices is used, requirements apply at the far end antenna connector (port B).

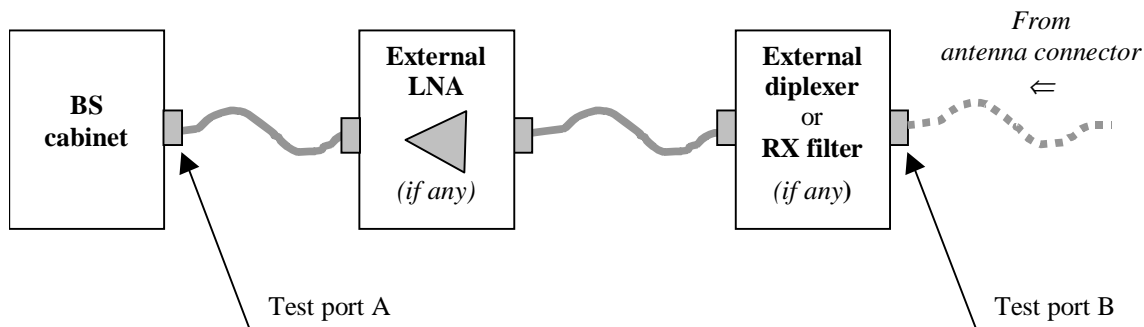

Figure 7.1: Receiver test ports

7.2 Reference sensitivity level

The reference sensitivity is the minimum receiver input power measured at the antenna connector at which the Bit Error Ratio (BER) does not exceed the specific value indicated in section 7.2.1.

7.2.1 Minimum requirement

For the measurement channel specified in Annex A, the reference sensitivity level and performance of the BS shall be as specified in Table 7.1.

Table 7.1: BS reference sensitivity levels

<u>Frequency Band</u>	<u>Measurement channel</u>	<u>BS reference sensitivity level (dBm)</u>	<u>BER</u>
I	12.2 kbps	-121 dBm	BER shall not exceed 0.001
II	12.2 kbps	[-121] dBm	BER shall not exceed 0.001
III	12.2 kbps	[-121] dBm	BER shall not exceed 0.001

Table 7.1: BS reference sensitivity levels

<u>Measurement channel</u>	<u>BS reference sensitivity level (dBm)</u>	<u>BER</u>
12.2 kbps	-121 dBm	BER shall not exceed 0.001

7.2.2 Maximum Frequency Deviation for Receiver Performance

The need for such a requirement is for further study.

7.3 Dynamic range

Receiver dynamic range is the receiver ability to handle a rise of interference in the reception frequency channel. The receiver shall fulfil a specified BER requirement for a specified sensitivity degradation of the wanted signal in the presence of an interfering AWGN signal in the same reception frequency channel.

7.3.1 Minimum requirement

The BER shall not exceed 0.001 for the parameters specified in Table 7.2.

Table 7.2 : Dynamic range

Parameter	Level	Unit
Data rate	12.2	kbps
Wanted signal	-91	dBm
Interfering AWGN signal	-73	dBm/3.84 MHz

7.4 Adjacent Channel Selectivity (ACS)

Adjacent channel selectivity (ACS) is a measure of the receiver ability to receive a wanted signal at its assigned channel frequency in the presence of an adjacent channel signal at a given frequency offset from the center frequency of the assigned channel. ACS is the ratio of the receiver filter attenuation on the assigned channel frequency to the receiver filter attenuation on the adjacent channel(s).

7.4.1 Minimum requirement

The BER shall not exceed 0.001 for the parameters specified in Table 7.3.

Table 7.3 : Adjacent channel selectivity

<u>Frequency band</u>	<u>Parameter</u>	<u>Level</u>	<u>Unit</u>
All	Data rate	12.2	kbps
	Fuw (Modulated)	5	MHz
I	Wanted signal	-115	dBm
	Interfering signal	-52	dBm
II	Wanted signal	[-115]	dBm
	Interfering signal	[-52]	dBm
III	Wanted signal	[-115]	dBm
	Interfering signal	[-52]	dBm

Table 7.3 : Adjacent channel selectivity

<u>Parameter</u>	<u>Level</u>	<u>Unit</u>
Data rate	12.2	kbps
Wanted signal	-115	dBm
Interfering signal	-52	dBm
Fuw (Modulated)	5	MHz

7.5 Blocking characteristics

The blocking characteristics is a measure of the receiver ability to receive a wanted signal at its assigned channel frequency in the presence of an unwanted interferer on frequencies other than those of the adjacent channels. The blocking performance shall apply at all frequencies as specified in the table 7.3(a) below, using a 1 MHz step size.

7.5.1 Minimum requirement

The static reference performance as specified in clause 7.2.1 should be met with a wanted and an interfering signal coupled to BS antenna input using the following parameters.

Table 7.4 : Blocking performance requirement

<u>Frequency Band</u>	<u>Center Frequency of Interfering Signal</u>	<u>Interfering Signal Level</u>	<u>Wanted Signal Level</u>	<u>Minimum Offset of Interfering Signal</u>	<u>Type of Interfering Signal</u>
I	1920 - 1980 MHz	-40 dBm	-115 dBm	10 MHz	WCDMA signal with one code
	1900 - 1920 MHz 1980 - 2000 MHz	-40 dBm	-115 dBm	10 MHz	WCDMA signal with one code
	1 MHz -1900 MHz 2000 MHz - 12750 MHz	-15 dBm	-115 dBm	=	CW carrier
II	1850 - 1910 MHz	[-40] dBm	[-115] dBm	10 MHz	WCDMA signal with one code
	1830 - 1850 MHz 1910 - 1930 MHz	[-40] dBm	[-115] dBm	10 MHz	WCDMA signal with one code
	1 MHz - 1830 MHz 1930 MHz - 12750 MHz	[-15] dBm	[-115] dBm	=	CW carrier
III	1710 – 1785 MHz	[-40] dBm	[-115] dBm	10 MHz	WCDMA signal with one code
	1690 - 1710 MHz 1785 – 1805 MHz	[-40] dBm	[-115] dBm	10 MHz	WCDMA signal with one code
	1 MHz - 1690 MHz 1805 MHz - 12750 MHz	[-15] dBm	[-115] dBm	=	CW carrier

Table 7.4 : Blocking performance requirement for operation in frequency bands in sub-clause 5.2(a)

Center Frequency of Interfering Signal	Interfering Signal Level	Wanted Signal Level	Minimum Offset of Interfering Signal	Type of Interfering Signal
1920 – 1980 MHz	-40 dBm	-115 dBm	10 MHz	WCDMA signal with one code
1900 – 1920 MHz 1980 – 2000 MHz	-40 dBm	-115 dBm	10 MHz	WCDMA signal with one code
1 MHz – 1900 MHz, and 2000 MHz – 12750 MHz	-15 dBm	-115 dBm	—	CW carrier

Table 7.5: Blocking performance requirement for operation in frequency bands in sub-clause 5.2(b)

Center Frequency of Interfering Signal	Interfering Signal Level	Wanted Signal Level	Minimum Offset of Interfering Signal	Type of Interfering Signal
1850 – 1910 MHz	-40 dBm	-115 dBm	10 MHz	WCDMA signal with one code
1830 – 1850 MHz 1910 – 1930 MHz	-40 dBm	-115 dBm	10 MHz	WCDMA signal with one code
1 MHz – 1830 MHz 1930 MHz – 12750 MHz	-15 dBm	-115 dBm	—	CW carrier

7.5.2 Minimum requirement (Narrow band blocking)

The BER shall not exceed 0.001 for the parameters specified in Table 7.5. This requirement is measure of a receiver’s ability to receive a W-CDMA signal at its assigned channel frequency in the presence of an unwanted narrow band interferer at a frequency which is less than the nominal channel spacing

Table 7.5: Narrow band blocking characteristics

Frequency Band	Wanted signal level	Interfering Signal Level	Minimum Offset Interfering Signal	Type of Interfering Signal
II	[-115] dBm	[-] dBm	[-] MHz	[-]
III	[-115] dBm	[-] dBm	[-] MHz	[-]

7.6 Intermodulation characteristics

Third and higher order mixing of the two interfering RF signals can produce an interfering signal in the band of the desired channel. Intermodulation response rejection is a measure of the capability of the receiver to receiver a wanted signal on its assigned channel frequency in the presence of two or more interfering signals which have a specific frequency relationship to the wanted signal.

7.6.1 Minimum requirement

The static reference performance as specified in clause 7.2.1 should be met when the following signals are coupled to BS antenna input:

- A wanted signal at the assigned channel frequency ~~with a signal level of -115 dBm.~~
- Two interfering signals with the ~~following~~ parameters specified in Table 7.6.-

Table 7.6 : Intermodulation performance requirement

<u>Frequency Band</u>	<u>Wanted signal level</u>	<u>Interfering Signal Level</u>	<u>Offset</u>	<u>Type of Interfering Signal</u>
I	-115 dBm	- 48 dBm	10 MHz	CW signal
		- 48 dBm	20 MHz	WCDMA signal with one code
II	[-115] dBm	[- 48] dBm	10 MHz	CW signal
		[- 48] dBm	20 MHz	WCDMA signal with one code
III	[-115] dBm	[- 48] dBm	10 MHz	CW signal
		[- 48] dBm	20 MHz	WCDMA signal with one code

Table 7.6 : Intermodulation performance requirement

<u>Interfering Signal Level</u>	<u>Offset</u>	<u>Type of Interfering Signal</u>
-48 dBm	10 MHz	CW signal
-48 dBm	20 MHz	WCDMA signal with one code

7.6.2 Minimum requirement (narrow band intermodulation)

The static reference performance as specified in clause 7.2.1 should be met when the following signals are coupled to BS antenna input:

- A wanted signal at the assigned channel frequency.
- Two interfering signals with the parameters specified in Table 7.7.

Table 7.7 : Narrow band intermodulation performance requirement

<u>Frequency Band</u>	<u>Wanted signal level</u>	<u>Interfering Signal Level</u>	<u>Offset</u>	<u>Type of Interfering Signal</u>
II	[-115] dBm	[] dBm		CW signal
		[] dBm		[]
III	[-115] dBm	[] dBm		CW signal
		[] dBm		[]

7.7 Spurious emissions

The spurious emissions power is the power of emissions generated or amplified in a receiver that appear at the BS receiver antenna connector. The requirements apply to all BS with separate RX and TX antenna port. The test shall be performed when both TX and RX are on with the TX port terminated.

For all BS with common RX and TX antenna port the transmitter spurious emission as specified in section 6.6.3 is valid.

7.7.1 Minimum requirement

The power of any spurious emission shall not exceed:

Table 7.7: Spurious emission minimum requirement

Band	Maximum level	Measurement Bandwidth	Note
1900 – 1980 MHz and 2010 – 2025 MHz	-78 dBm	3.84 MHz	
9 kHz – 1 GHz	-57 dBm	100 kHz	
1 GHz – 12.75 GHz	-47 dBm	1 MHz	With the exception of frequencies between 12.5 MHz below the first carrier frequency and 12.5 MHz above the last carrier frequency used by the BS.

Table 7.7.1: General spurious emission minimum requirements

Frequency band	Maximum level	Measurement Bandwidth	Note
9 kHz - 1 GHz	-57 dBm	100 kHz	
1 GHz - 12.75 GHz	-47 dBm	1 MHz	With the exception of frequencies between 12.5 MHz below the first carrier frequency and 12.5 MHz above the last carrier frequency used by the BS.

Table 7.7.2: Additional spurious emission requirements

Frequency Band	Frequency band	Maximum level	Measurement Bandwidth	Note
I	1900 – 1980 MHz 2010 – 2025 MHz	-78 dBm	3.84 MHz	
II	1850 – 1910 MHz	-78 dBm	3.84 MHz	
III	1710 – 1785 MHz 1900 – 1920 MHz 2010 – 2025 MHz	-78 dBm	3.84 MHz	