

**TSG-RAN Meeting #11
Palm Springs, CA, U.S.A., 13-16 March 2001**

RP-010059

Title: Agreed CRs to TS 25.213

Source: TSG-RAN WG1

Agenda item: 5.1.3

No.	R1 T-doc	Spec	CR	Rev	Subject	Cat	V_old	V_new
1	R1-01-0247	25.213	038	-	Clarification of channelization codes when SF=512	F	3.4.0	3.5.0
2	R1-01-0348	25.213	039	1	Clarification of the scrambling code of a power control preamble	F	3.4.0	3.5.0

CR-Form-v3

CHANGE REQUEST

⌘ **25.213 CR 038** ⌘ rev **-** ⌘ Current version: **3.4.0** ⌘

For **HELP** on using this form, see bottom of this page or look at the pop-up text over the ⌘ symbols.

Proposed change affects: ⌘ (U)SIM ME/UE Radio Access Network Core Network

Title:	⌘ Clarification of channelization codes when SF=512		
Source:	⌘ TSG RAN WG1		
Work item code:	⌘	Date:	⌘ 21-Feb-2001
Category:	⌘ F	Release:	⌘ R99
	Use <u>one</u> of the following categories: F (essential correction) A (corresponds to a correction in an earlier release) B (Addition of feature), C (Functional modification of feature) D (Editorial modification) Detailed explanations of the above categories can be found in 3GPP TR 21.900.		Use <u>one</u> of the following releases: 2 (GSM Phase 2) R96 (Release 1996) R97 (Release 1997) R98 (Release 1998) R99 (Release 1999) REL-4 (Release 4) REL-5 (Release 5)

Reason for change:	⌘ Clarification of scope of operation using proper 3GPP terms		
Summary of change:	⌘ Restriction of use of SF=512 spreading codes is by cell and based on use of timing adjustment.		
Consequences if not approved:	⌘ It is not currently clear when restriction of use of odd/even OVFSF codes with SF=512 applies. This would leave an ambiguity in the Uu interface.		

Clauses affected:	⌘ 5.2.1		
Other specs affected:	<input type="checkbox"/> Other core specifications <input type="checkbox"/> Test specifications <input type="checkbox"/> O&M Specifications	⌘	
Other comments:	⌘		

How to create CRs using this form:

Comprehensive information and tips about how to create CRs can be found at: http://www.3gpp.org/3G_Specs/CRs.htm. Below is a brief summary:

- 1) Fill out the above form. The symbols above marked ⌘ contain pop-up help information about the field that they are closest to.
- 2) Obtain the latest version for the release of the specification to which the change is proposed. Use the MS Word "revision marks" feature (also known as "track changes") when making the changes. All 3GPP specifications can be downloaded from the 3GPP server under <ftp://www.3gpp.org/specs/> For the latest version, look for the directory name with the latest date e.g. 2000-09 contains the specifications resulting from the September 2000 TSG meetings.
- 3) With "track changes" disabled, paste the entire CR form (use CTRL-A to select it) into the specification just in front of the clause containing the first piece of changed text. Delete those parts of the specification which are not relevant to the change request.

5.2.1 Channelization codes

The channelization codes of figure 8 are the same codes as used in the uplink, namely Orthogonal Variable Spreading Factor (OVSF) codes that preserve the orthogonality between downlink channels of different rates and spreading factors. The OVSF codes are defined in figure 4 in section 4.3.1.

The channelization code for the Primary CPICH is fixed to $C_{ch,256,0}$ and the channelization code for the Primary CCPCH is fixed to $C_{ch,256,1}$. The channelization codes for all other physical channels are assigned by UTRAN.

With the spreading factor 512 a specific restriction is applied. When the code word $C_{ch,512,n}$, with $n=0,2,4,\dots,510$, is used in soft handover, then the code word $C_{ch,512,n+1}$ is not allocated in the **Node-B cells** where timing adjustment is to be used. Respectively if $C_{ch,512,n}$, with $n=1,3,5,\dots,511$ is used, then the code word $C_{ch,512,n-1}$ is not allocated in the **Node-B cells** where timing adjustment is to be used. This restriction shall not apply ~~for the softer handover operation or~~ in cases ~~UTRAN is synchronised to such a level that~~ where timing adjustments in soft handover are not used with spreading factor 512.

When compressed mode is implemented by reducing the spreading factor by 2, the OVSF code used for compressed frames is:

- $C_{ch,SF/2,\lfloor n/2 \rfloor}$ if ordinary scrambling code is used.
- $C_{ch,SF/2,n \bmod SF/2}$ if alternative scrambling code is used (see section 5.2.2);

where $C_{ch,SF,n}$ is the channelization code used for non-compressed frames.

In case the OVSF code on the PDSCH varies from frame to frame, the OVSF codes shall be allocated such a way that the OVSF code(s) below the smallest spreading factor will be from the branch of the code tree pointed by the smallest spreading factor used for the connection. This means that all the codes for UE for the PDSCH connection can be generated according to the OVSF code generation principle from smallest spreading factor code used by the UE on PDSCH.

In case of mapping the DSCH to multiple parallel PDSCHs, the same rule applies, but all of the branches identified by the multiple codes, corresponding to the smallest spreading factor, may be used for higher spreading factor allocation.

CHANGE REQUEST

⌘ **25.213** **CR 039** ⌘ rev **1** ⌘ Current version: **3.4.0** ⌘

For **HELP** on using this form, see bottom of this page or look at the pop-up text over the ⌘ symbols.

Proposed change affects: ⌘ (U)SIM ME/UE Radio Access Network Core Network

Title:	⌘ Clarification of the scrambling code of a power control preamble		
Source:	⌘ TSG RAN WG1		
Work item code:	⌘	Date:	⌘ 28th, February, 2001
Category:	⌘ F	Release:	⌘ R99
	Use <u>one</u> of the following categories: F (essential correction) A (corresponds to a correction in an earlier release) B (Addition of feature), C (Functional modification of feature) D (Editorial modification) Detailed explanations of the above categories can be found in 3GPP TR 21.900.		Use <u>one</u> of the following releases: 2 (GSM Phase 2) R96 (Release 1996) R97 (Release 1997) R98 (Release 1998) R99 (Release 1999) REL-4 (Release 4) REL-5 (Release 5)

Reason for change:	⌘ Section 4.3.2.4 Current power control preamble length can represent by the number of the frame. So the text of scrambling code alignment should be removed. Section 5.1 The reference text should be TS25.211. Current spec refers to TS25.201 as SCH transmission.
Summary of change:	⌘ Section 4.3.2.4 The text of scrambling code alignment is removed. Section 5.1 The reference number is modified.
Consequences if not approved:	⌘ Section 4.3.2.4 The text confuse the people who read this. Section 5.1 The reader refer to wrong reference and confuse.

Clauses affected:	⌘ 4.3.2.4, 5.1		
Other specs affected:	<input type="checkbox"/> Other core specifications <input type="checkbox"/> Test specifications <input type="checkbox"/> O&M Specifications	⌘	
Other comments:	⌘		

How to create CRs using this form:

Comprehensive information and tips about how to create CRs can be found at: http://www.3gpp.org/3G_Specs/CRs.htm. Below is a brief summary:

- 1) Fill out the above form. The symbols above marked ⌘ contain pop-up help information about the field that they are closest to.

- 2) Obtain the latest version for the release of the specification to which the change is proposed. Use the MS Word "revision marks" feature (also known as "track changes") when making the changes. All 3GPP specifications can be downloaded from the 3GPP server under <ftp://www.3gpp.org/specs/> For the latest version, look for the directory name with the latest date e.g. 2000-09 contains the specifications resulting from the September 2000 TSG meetings.
- 3) With "track changes" disabled, paste the entire CR form (use CTRL-A to select it) into the specification just in front of the clause containing the first piece of changed text. Delete those parts of the specification which are not relevant to the change request.

4.3.2.4 DPCCH/DPDCH scrambling code

The code used for scrambling of the uplink DPCCH/DPDCH may be of either long or short type. When the scrambling code is formed, different constituent codes are used for the long and short type as defined below.

The n :th uplink scrambling code for DPCCH/DPDCH, denoted $S_{\text{dpch},n}$, is defined as:

$$S_{\text{dpch},n}(i) = C_{\text{long},n}(i), \quad i = 0, 1, \dots, 38399, \text{ when using long scrambling codes;}$$

where the lowest index corresponds to the chip transmitted first in time and $C_{\text{long},n}$ is defined in section 4.3.2.2.

The n :th uplink scrambling code for DPCCH/DPDCH, denoted $S_{\text{dpch},n}$, is defined as:

$$S_{\text{dpch},n}(i) = C_{\text{short},n}(i), \quad i = 0, 1, \dots, 38399, \text{ when using short scrambling codes;}$$

where the lowest index corresponds to the chip transmitted first in time and $C_{\text{short},n}$ is defined in section 4.3.2.3.

~~If a power control preamble is used to initialise a DCH, the scrambling code for the DPCCH during the power control preamble shall be the same as that to be used afterwards. The phase of the scrambling code shall be such that the end of the code is aligned with the frame boundary at the end of the power control preamble.~~

5.1 Spreading

Figure 8 illustrates the spreading operation for all downlink physical channels except SCH, i.e. for P-CCPCH, S-CCPCH, CPICH, AICH, PICH, PDSCH, and downlink DPCH. The non-spread physical channel consists of a sequence of real-valued symbols. For all channels except AICH, the symbols can take the three values +1, -1, and 0, where 0 indicates DTX. For AICH, the symbol values depend on the exact combination of acquisition indicators to be transmitted, compare [2] Section 5.3.3.6.

Each pair of two consecutive symbols is first serial-to-parallel converted and mapped to an I and Q branch. The mapping is such that even and odd numbered symbols are mapped to the I and Q branch respectively. For all channels except AICH, symbol number zero is defined as the first symbol in each frame. For AICH, symbol number zero is defined as the first symbol in each access slot. The I and Q branches are then spread to the chip rate by the same real-valued channelization code $C_{ch,SF,m}$. The sequences of real-valued chips on the I and Q branch are then treated as a single complex-valued sequence of chips. This sequence of chips is scrambled (complex chip-wise multiplication) by a complex-valued scrambling code $S_{dl,n}$. In case of P-CCPCH, the scrambling code is applied aligned with the P-CCPCH frame boundary, i.e. the first complex chip of the spread P-CCPCH frame is multiplied with chip number zero of the scrambling code. In case of other downlink channels, the scrambling code is applied aligned with the scrambling code applied to the P-CCPCH. In this case, the scrambling code is thus not necessarily applied aligned with the frame boundary of the physical channel to be scrambled.

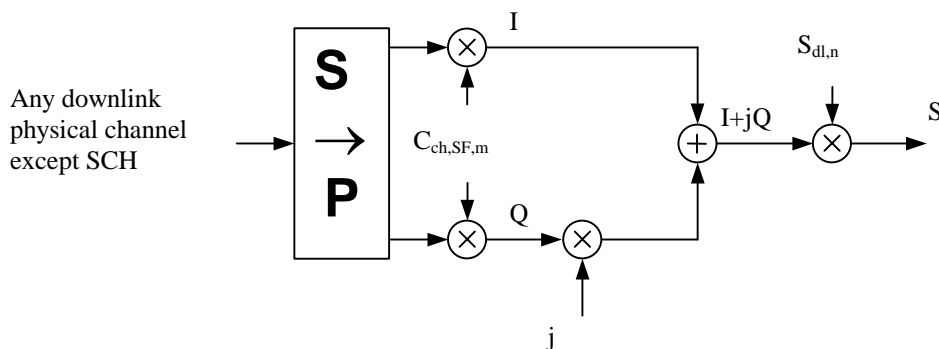

Figure 8: Spreading for all downlink physical channels except SCH

Figure 9 illustrates how different downlink channels are combined. Each complex-valued spread channel, corresponding to point S in Figure 8, is separately weighted by a weight factor G_i . The complex-valued P-SCH and S-SCH, as described in [24], section 5.3.3.4, are separately weighted by weight factors G_p and G_s . All downlink physical channels are then combined using complex addition.

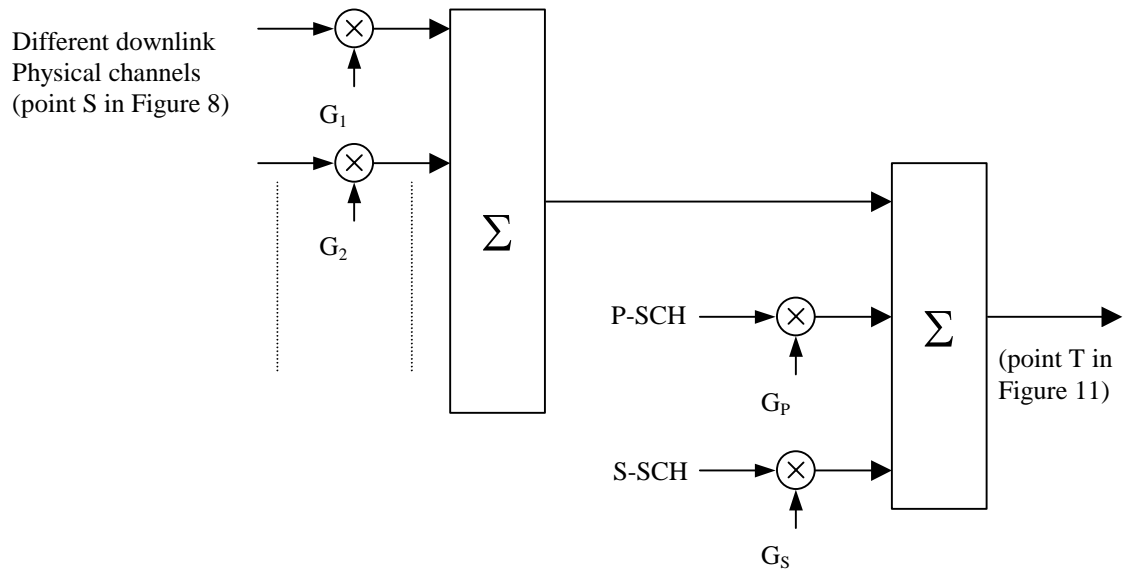

Figure 9: Spreading and modulation for SCH and P-CCPCH