

TSG RAN meeting #9  
20 – 22 September 2000  
Oahu, Hawaii

---

Agenda Item: 8  
Source: ITU Ad Hoc Contact Person  
Title: Final revised Overviews of the FDD and the TDD components  
Document for: Approval

---

3GPP TSG RAN thanks ITU-R WP 8F for its further liaison on the updating of Recommendation ITU-R M.1457.

3GPP TSG RAN wishes to revise Recommendation ITU-R M.1457 for the year 2000 revision. Relevant material is attached to this liaison to in line with the process outlined in the previous received liaison statement.

In particular, 3GPP TSG RAN has revised sections 5.1.1 (IMT-2000 CDMA DS – Overview of the Radio Interface) and 5.3.1 (IMT-2000 CDMA TDD – Overview of the Radio Interface) in order to reflect the current status of the harmonization initiatives on UTRA TDD. Sections 5.1.2 (IMT-2000 CDMA Direct Spread – Detailed Specification of the Radio Interface) and 5.3.2 (IMT-2000 CDMA TDD - Detailed Specification of the Radio Interface) have also been updated in order to address the most recently approved Deliverables.

Final revisions of sections 5.1.1 (IMT-2000 CDMA DS – Overview of the Radio Interface) and 5.3.1 (IMT-2000 CDMA TDD – Overview of the Radio Interface) are attached at Annex 1 and Annex 2, respectively. Final versions of sections 5.1.2 and 5.3.2 are submitted in separate documents by each Organisational Partner participating in 3GPP.

For clarity, a summary of the changes involved in this update is attached at Annex 3. In the context of the proposed review of the WP8F process for updating Recommendation ITU-R M.1457, 3GPP TSG RAN judges that the changes proposed to sections 5.1.1, 5.1.2, 5.3.1 and 5.3.2 constitute a routine update.

3GPP TSG RAN looks forward to continuing fruitful cooperation with ITU-R WP 8F.

[See file FDDOver]

ANNEX 2

[See file TDDOverR]

ANNEX 3

**Summary of the main updates in sections 5.1.1 and 5.3.1**

**Section 5.1.1:**

- Update of Layer 2: Packet Data Convergence Protocol (PDCP) sublayer and Broadcast/Multicast Control (BMC) sublayer included.
- Update of physical channels for the CPCH access procedure
- Update of summary of major technical parameters table

**Section 5.3.1:**

- Update of the terminology: '1.28 Mcps TDD option' and '3.84 Mcps TDD option' are now used.
  - Update of Layer 2: Packet Data Convergence Protocol (PDCP) sublayer and Broadcast/Multicast Control (BMC) sublayer included.
  - Deletion of all ODMA related material
  - Update of summary of major technical parameters table
-

## 5.1 IMT-2000 CDMA Direct Spread

### 5.1.1 Overview of the radio interface

#### 5.1.1.1 Introduction

The IMT-2000 radio interface specifications for CDMA Direct Spread technology are developed by a partnership of SDOs<sup>2</sup>. This interface is called the Universal Terrestrial Radio Access (UTRA) Frequency Division Duplex (FDD) or Wideband CDMA (WCDMA).

These radio interface specifications have been developed with the strong objective of harmonization with the TDD component (see Section 5.3) to achieve maximum commonality. This was achieved by harmonization of important parameters of the physical layer and a common set of protocols in the higher layers are specified for both FDD and TDD.

In the development of this radio interface the core network specifications are based on an evolved GSM-MAP, but the specifications include the necessary capabilities for operation with an evolved ANSI-41 based core network.

The radio access scheme is direct-sequence CDMA with information spread over approximately 5 MHz bandwidth with a chip rate of 3.84 Mcps. The radio interface is defined to carry a wide range of services to efficiently support both circuit-switched services (e.g. PSTN- and ISDN-based networks) as well as packet-switched services (e.g. IP-based networks). A flexible radio protocol has been designed where several different services such as speech, data, multimedia can simultaneously be used by a user and multiplexed on a single carrier. The defined radio bearer services provide for both real-time and non-real time services support by employing transparent and/or non-transparent data transport. The quality of service can be adjusted in terms such as delay, bit error ratio, frame error ratio.

#### 5.1.1.2 Radio access network architecture

The overall architecture of the system is shown in Figure 3.

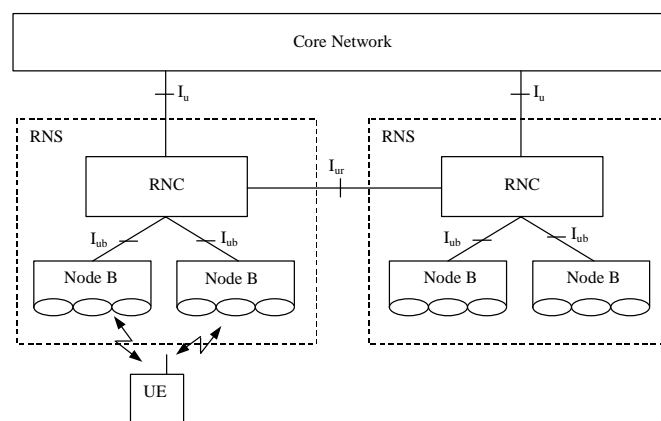

FIGURE 3

**Radio access network architecture (cells are indicated by ellipses)**

<sup>2</sup> Currently, these specifications are developed within the Third Generation Partnership Project (3GPP) where the participating SDOs are ARIB, CWTS, ETSI, T1, TTA and TTC.

The architecture of this radio interface consists of a set of Radio Network Subsystems (RNS) connected to the Core Network through the  $I_{u}$  interface. A RNS consists of a Radio Network Controller (RNC) and one or more entities called Node B. Node B are connected to the RNC through the  $I_{ub}$  interface. Node B can handle one or more cells. The RNC is responsible for the handover decisions that require signalling to the User Equipment (UE). In case macro diversity between different Node Bs is used the RNC comprises a combining/splitting function to support it. The Node B can comprise an optional combining/splitting function to support macro diversity inside a Node B. ~~Inside this radio interface, the RNCs of the Radio Network Subsystems can be interconnected together through the  $I_{ur}$ .~~ The  $I_{u}$  and  $I_{ur}$  are logical interfaces. The  $I_{ur}$  can be conveyed over physical direct connection between RNCs or via any suitable transport network.

Figure 4 shows the radio interface protocol architecture for the radio access network. On a general level, the protocol architecture is similar to the current ITU-R protocol architecture as described in Recommendation ITU-R M.1035. Layer 2 (L2) is split into ~~two~~ the following sublayers: Radio Link Control (RLC), ~~and~~ Medium Access Control (MAC), Packet Data Convergence Protocol (PDCP) and Broadcast/Multicast Control (BMC). Layer 3 (L3) and RLC are divided into Control (C-) and User (U-) planes. In the C-plane, L3 is partitioned into sublayers where the lowest sublayer, denoted as Radio Resource Control (RRC), interfaces with L2. The higher layer signalling such as Mobility Management (MM) and Call Control (CC) are assumed to belong to the core network. There are no L3 elements in this radio interface for the U-plane.

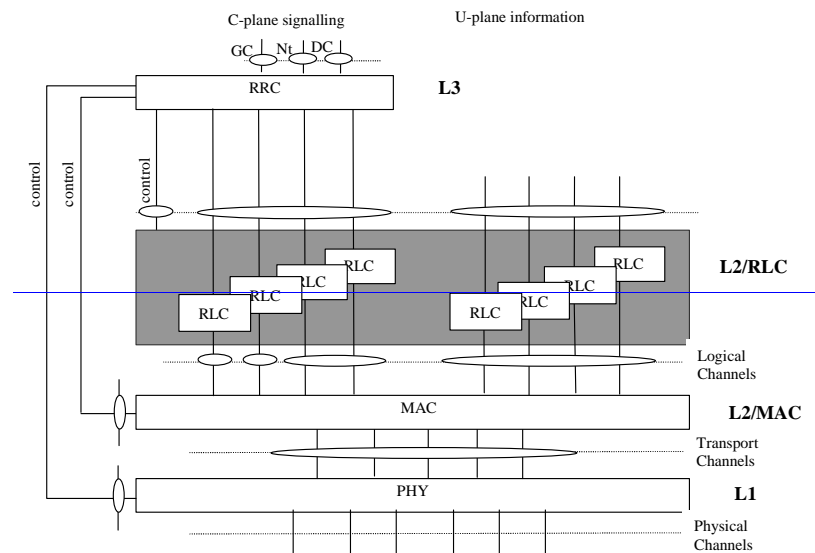

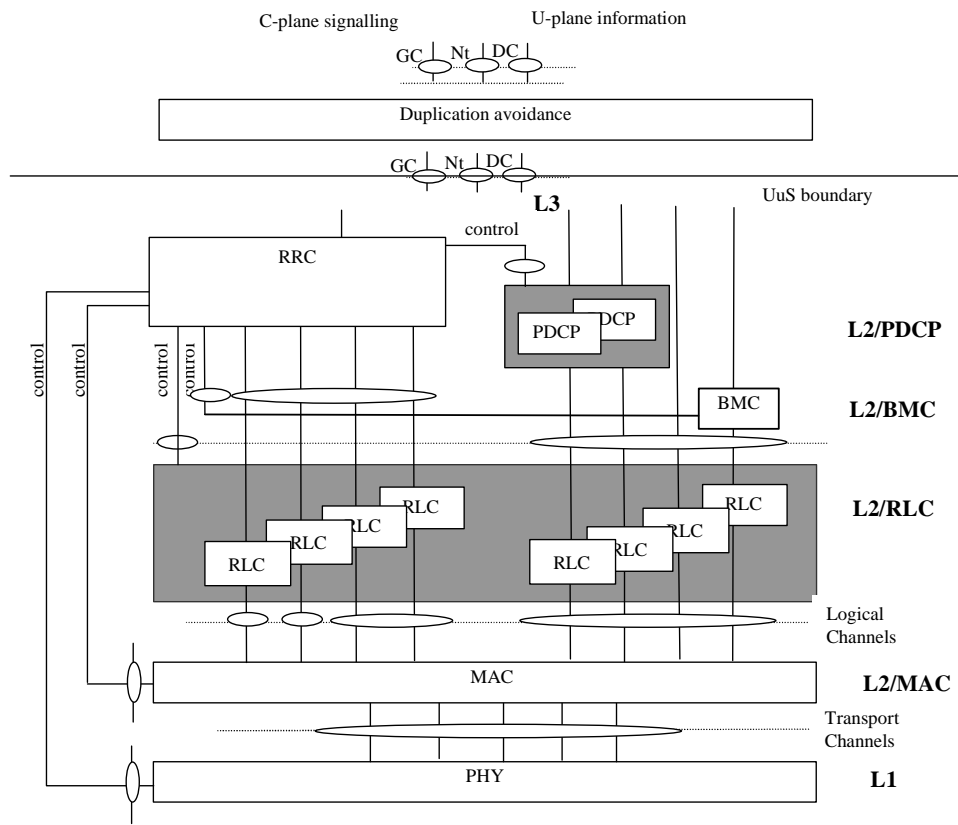

FIGURE 4

### Radio interface protocol architecture of the RRC sublayer (L2 and L1)

Each block in Figure 4 represents an instance of the respective protocol. Service Access Points (SAP) for peer-to-peer communication are marked with circles at the interface between sublayers. The SAPs between RLC and the MAC sublayer provide the logical channels. The type of information transferred characterizes a logical channel. The logical channels are divided into control channels and traffic channels. The different types are not further described in this overview. The SAP between MAC and the physical layer provides the transport channels. A transport channel is characterized by how the information is transferred over the radio interface (see Section 5.1.1.3.2 for an overview of the types defined). The physical layer generates the physical channels that will be transmitted over the air. A physical channel corresponds to a certain carrier frequency, code, and, on the uplink, relative phase ( $0$  or  $\pi/2$ ). In the C-plane, the interface between RRC and higher L3 sublayers (CC, MM) is defined by the General Control (GC), Notification (Nt) and Dedicated Control (DC) SAPs. These SAPs are not further discussed in this overview.

Also shown in the figure are connections between RRC and MAC as well as RRC and L1 providing local inter-layer control services (including measurement results). An equivalent control interface exists between RRC and the RLC sublayer. These interfaces allow the RRC to control the configuration of the lower layers. For this purpose separate control SAPs are defined between RRC and each lower layer (RLC, MAC, and L1).

Figure 5 shows the general structure and some additional terminology definitions of the channel formats at the various sublayer interfaces indicated in Figure 4. The figure indicates how higher layer Service Data Units (SDUs) and Protocol Data Units (PDUs) are segmented and multiplexed to

transport blocks to be further treated by the physical layer. The transmission chain of the physical layer is described in the next section.

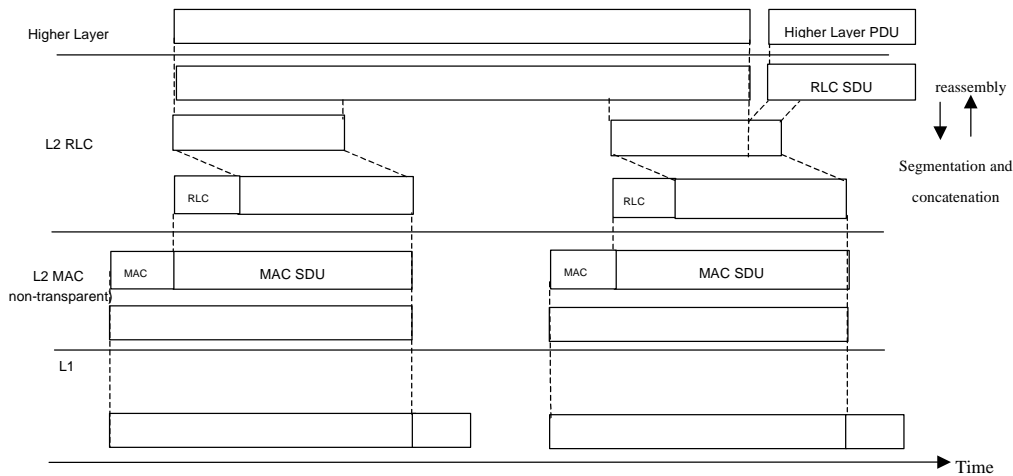

FIGURE 5

**Data flow for a service using a non-transparent RLC and non-transparent MAC (see Sections 5.1.1.4.1-2 for further definitions of the MAC and RLC services and functionality)**

### 5.1.1.3 Physical layer

#### 5.1.1.3.1 Physical layer functionality and building blocks

The physical layer includes the following functionality:

- macrodiversity distribution/combining and soft handover execution;
- error detection on transport channels and indication to higher layers;
- Forward Error Control (FEC) encoding/decoding of transport channels;
- multiplexing of transport channels and demultiplexing of coded composite transport channels;
- rate matching (data multiplexed on Dedicated Channels (DCH));
- mapping of coded composite transport channels on physical channels;
- power weighting and combining of physical channels;
- modulation and spreading/demodulation and despreading of physical channels;
- frequency and time (chip, bit, slot, frame) synchronization;
- radio characteristics measurements including Frame Error Rate (FER), Signal-to-Interference (SIR), Interference Power Level, etc., and indication to higher layers;
- closed-loop power control;
- Radio Frequency (RF) processing.

Figure 6 gives the physical layer transmission chain for the user plane data, i.e. from the level of transport channels down to the level of physical channel. The figure shows how several transport channels can be multiplexed onto one or more dedicated physical data channels (DPDCH).

The cyclic redundancy check (CRC) provides for error detection of the transport blocks for the particular transport channel. The CRC can take the length zero (no CRC), 8, 16 or 24 bits depending on the service requirements.

The transport block concatenation and code block segmentation functionality performs serial concatenation of those transport blocks that will be sent in one transport time interval and any code block segmentation if necessary.

The types of channel coding defined are convolutional coding, turbo coding and no coding. Real-time services use only FEC encoding while non real-time services use a combination of FEC and ARQ. The ARQ functionality resides in the RLC layer of Layer 2. The convolutional coding rates are 1/2 or 1/3 while the rate is 1/3 for turbo codes. The possible interleaving depths are 10, 20, 40 or 80 milliseconds.

The radio frame segmentation performs padding of bits. The rate matching adapts any remaining differences of the bit rate so the number of outgoing bits fit to the available bit rates of the physical channels. Repetition coding and/or puncturing is used for this purpose.

The Transport Channel multiplexing stage combines transport channels in a serial fashion. This is done every 10 milliseconds. The output of this operation is also called coded composite transport channels.

If several physical channels will be used to transmit the data, the split is made in the physical channel segmentation unit.

The downlink can use discontinuous transmission (DTX) on a slot to slot basis for variable rate transmission. The insertions could either be at fixed or at flexible positions.

#### **5.1.1.3.2 Transport channels**

The interface to the MAC layer is the transport channels (see Figure 4). The transport channels define how and with which type of characteristics the data is transferred by the physical layer. They are categorized into dedicated channels or common channels where many UEs are sharing the latter type. Introducing an information field containing the address then does the address resolution, if needed. The physical channel itself defines a dedicated channel. Thus no specific address is needed for the UE.

Table 1 summarizes the different types of available transport channels and their intended use.

The random access channel on the uplink is contention-based while the dedicated channel is reservation-based.

#### **5.1.1.3.3 Transport channels to physical channel mapping**

The transport channels are mapped onto the physical channels. Figure 7 shows the different physical channels and summarizes the mapping of transport channels onto physical channels. Each physical channel has its tailored slot content. The slot content for the DCH is shown in Section 5.1.1.3.4.

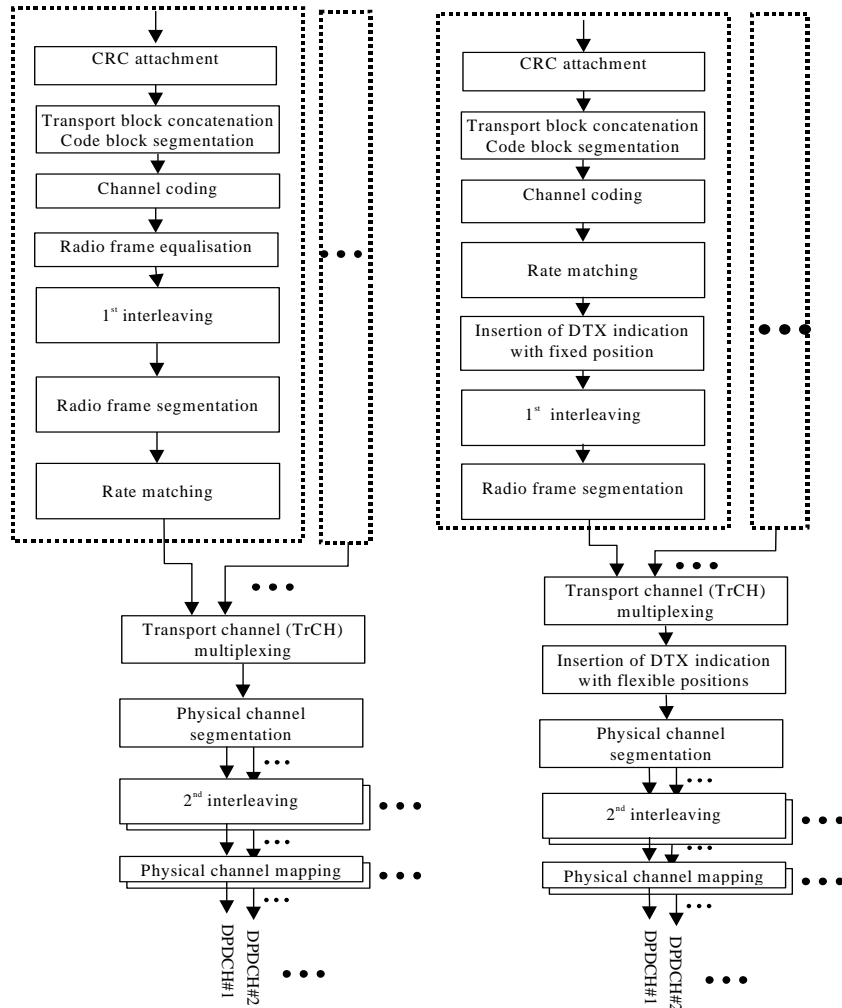

FIGURE 6

Transport channel multiplexing structure (left: UL; right: DL)

TABLE 1

Defined transport channels and their intended use

Transport channel	Type and direction	Used for
DCH (Dedicated channel)	Dedicated; uplink and downlink	User or control information to a UE (entire cell or part of cell (lobe-forming))
BCH (Broadcast channel)	Common; downlink	Broadcast system and cell specific information
FACH (Forward access channel)	Common; downlink	Control information when system knows UE location or short user packets to a UE
PCH (Paging channel)	Common; downlink	Control information to UEs when good sleep mode properties are needed, e.g. idle mode operation
RACH (Random access channel)	Common; uplink	Control information or short user packets from an UE
CPCH (Common packet channel)	Common; uplink	FDD only. Short and medium sized user packets. Always associated with a downlink channel for



		power control
DSCH (Downlink shared channel)	Common; downlink	Carries dedicated user data and control information using a shared channel.

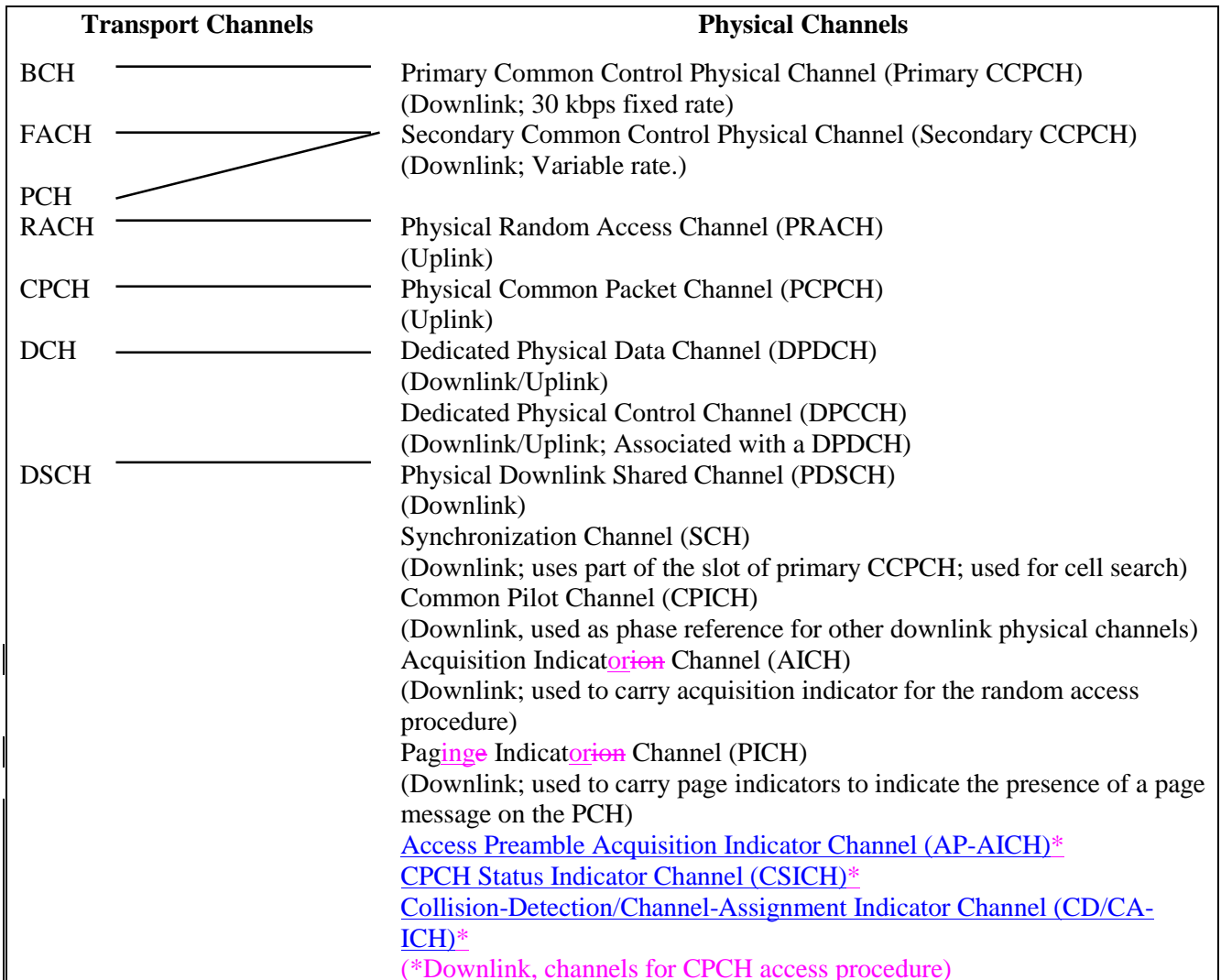

FIGURE 7

### Transport channels, physical channels and their mapping

#### 5.1.1.3.4 Physical frame structure

The basic physical frame rate is 10 milliseconds with 15 slots. Figure 8 shows the frame structure.

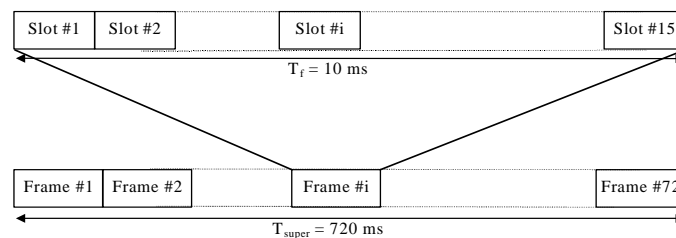

FIGURE 8

**Basic frame structure**

Figure 9 shows the content for a slot used by the DCH. The uplink physical channels DPDCH and DPCCH are I/Q multiplexed while the downlink channels are time multiplexed. The DPDCH, the channel where the user data is transmitted on, is always associated with a DPCCH containing Layer 1 control information. The Transport Format Combination Indicator (TFCI) field is used for indicating the demultiplexing scheme of the data stream. The TFCI field does not exist for combinations that are static (i.e. fixed bit rate allocations) or blind transport format detection is employed. The Feedback Information (FBI) field is used for transmit and site diversity functions. The Transmit Power Control (TPC) bits are used for power control.

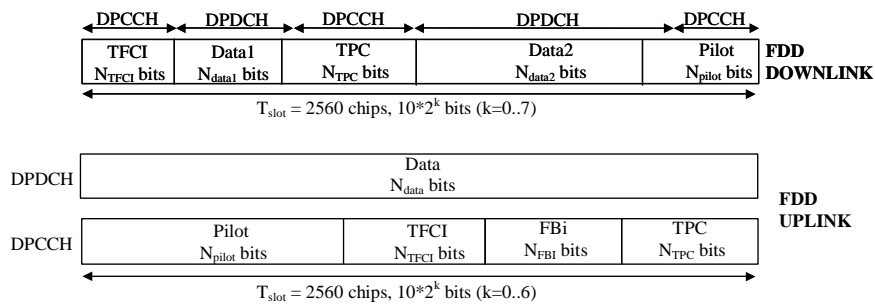

FIGURE 9

**The slot content for the DPDCH/DPCCH**

For the uplink, the DPDCH bit rate can vary between 15 up to 960 kbps using spreading factors 256 down to 4. To obtain higher bit rates for a user several physical channels can be used. The bit rate of the DPCCH is fixed to 15 kbps. For the downlink the DPDCH bit rate is variable between 15 up to 1 920 kbps with a spreading factor ranging from 512 down to 4. Note that the symbol bit rate is equal to the channel bit rate for the uplink while it is half of the channel bit rate for the downlink.

A Common Pilot Channel (CPICH) is defined. It is an unmodulated downlink channel, that is the phase reference for other downlink physical channels. There is always one primary CPICH in each cell. There may also be additional secondary CPICHs in a cell.

To be able to support inter-frequency handover as well as measurements on other carrier frequencies or carriers of other systems, like GSM, a compressed mode of operation is defined. The function is implemented by having some slots empty, but without deleting any user data. Instead the user data is transmitted in the remaining slots. The number of slots that is not used can be variable with a minimum of three slots (giving minimum idle lengths of at least 1.73 milliseconds). The slots can be empty either in the middle of a frame or at the end and in the beginning of the consecutive frame. If and how often is controlled by the RRC functionality in Layer 3.

### 5.1.1.3.5 Spreading, modulation and pulse shaping

#### Uplink

Spreading consists of two operations. The first is the channelization operation, which transforms every data symbol into a number of chips, thus increasing the bandwidth of the signal. The number of chips per data symbol is called the Spreading Factor (SF). The second operation is the scrambling operation, where a scrambling code is applied to the spread signal.

In the channelization operation, data symbol on so-called I- and Q-branches are independently multiplied with a code. The channelization codes are Orthogonal Variable Spreading Factor (OVSF) codes that preserve the orthogonality between a user's different physical channels. With the scrambling operation, the resultant signals on the I- and Q-branches are further multiplied by complex-valued scrambling code, where I and Q denote real and imaginary parts, respectively. Note that before complex multiplication binary values 0 and 1 are mapped to +1 and -1, respectively. Figure 10 illustrates the spreading and modulation for the case of multiple uplink DPDCHs. Note that this figure only shows the principle, and does not necessarily describe an actual implementation. Modulation is dual-channel QPSK (i.e. separate BPSK on I- and Q-channel), where the uplink DPDCH and DPCCH are mapped to the I and Q branch respectively. The I and Q branches are then spread to the chip rate with two different channelization codes and subsequently complex scrambled by a UE specific complex scrambling code  $C_{\text{scramb}}$ . There are  $2^{24}$  uplink-scrambling codes. Either short (256 chips from the family of S(2) codes) or long (38 400 chips equal to one frame length, Gold code based) scrambling codes is used on the uplink. The short scrambling code is typically used in cells where the base station is equipped with an advanced receiver, such as a multi-user detector or interference canceller whereas the long codes gives better interference averaging properties.

The pulse-shaping filters are root-raised cosine (RRC) with roll-off  $\alpha = 0.22$  in the frequency domain.

The modulation of both DPCCH and DPDCH is BPSK. The modulated DPCCH is mapped to the Q-branch, while the first DPDCH is mapped to the I-branch. Subsequently added DPDCHs are mapped alternatively to the I or Q-branches.

#### Downlink

Figure 11 illustrates the spreading and modulation for the downlink DPCH. Data modulation is QPSK where each pair of two bits are serial-to-parallel (S/P) converted and mapped to the I and Q branch respectively. The I and Q branch are then spread to the chip rate with the same channelization code  $C_{\text{ch}}$  (real spreading) and subsequently scrambled by the scrambling code  $C_{\text{scramb}}$  (complex scrambling).

The channelization codes are the same codes as used in the uplink that preserve the orthogonality between downlink channels of different rates and spreading factors. There are a total of  $512 \times 512 = 262,144$  scrambling codes, numbered 0...262,143. The scrambling codes are divided into 512 sets each of a primary scrambling code and 511 secondary scrambling codes. Each cell is allocated one and only one primary scrambling code. The primary CCPCH is always transmitted using the primary scrambling code. The other downlink physical channels can be transmitted with either the primary scrambling code or a secondary scrambling code from the set associated with the primary scrambling code of the cell.

The pulse-shaping filters are root raised cosine (RRC) with roll-off  $\alpha = 0.22$  in the frequency domain.

FIGURE 10

Spreading/modulation for uplink DPDCH/DPCCH

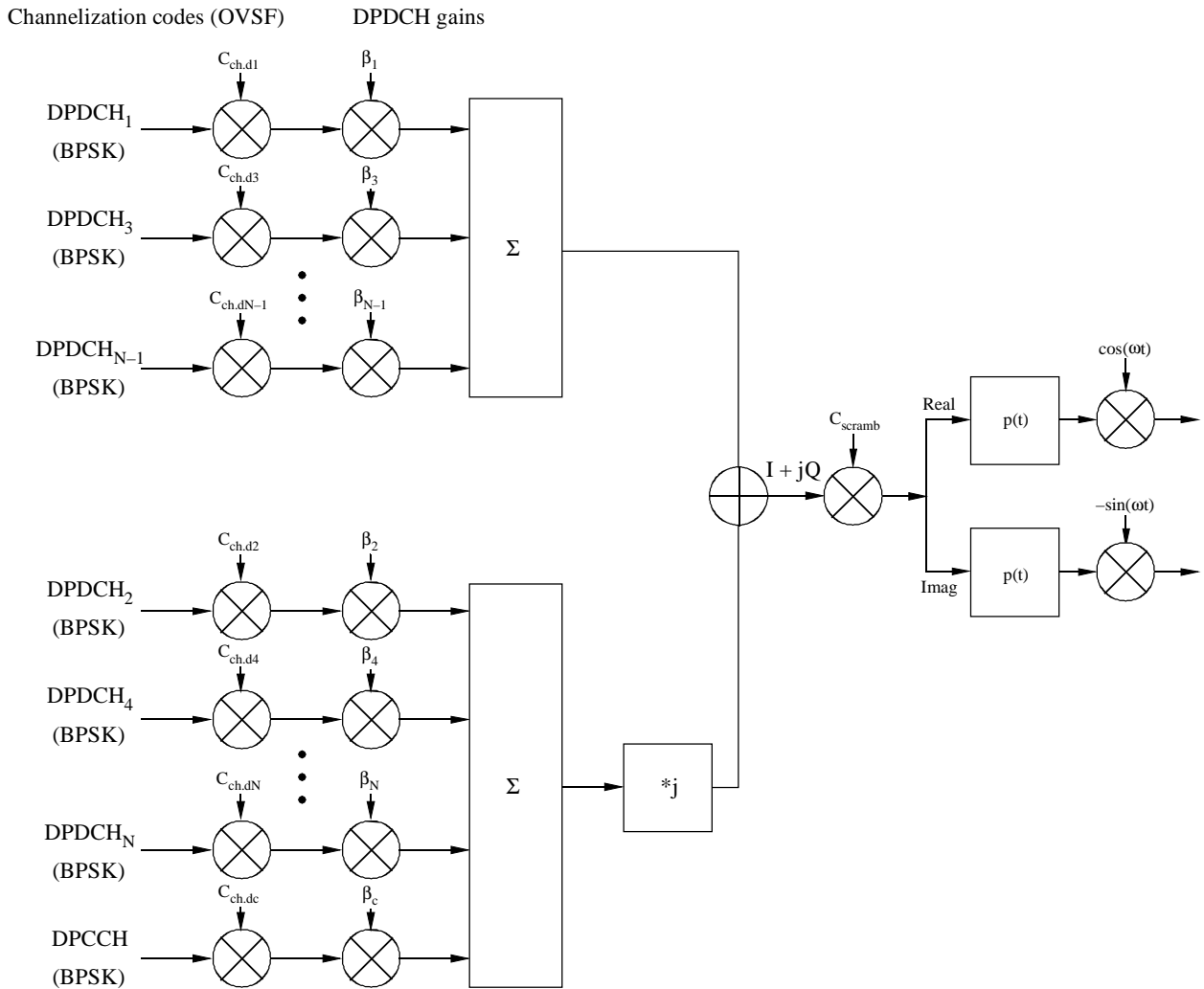

Temp 8/126-5.8

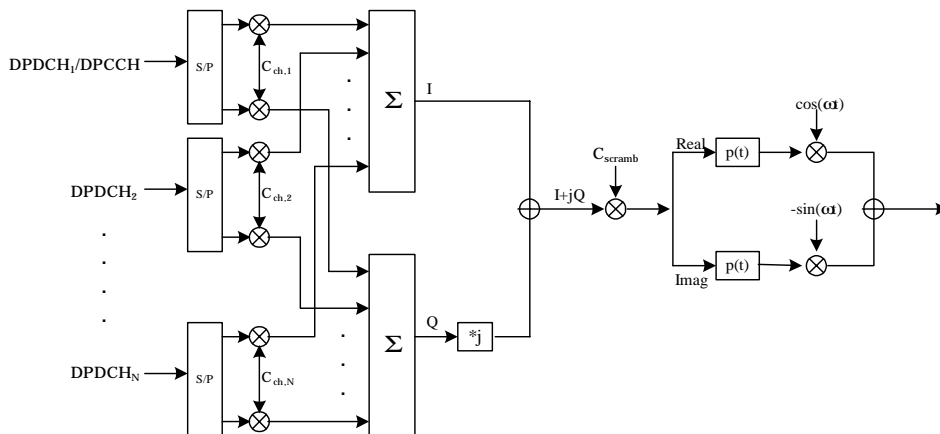

FIGURE 11

**Spreading/modulation for downlink DPCCH**

**5.1.1.4 Layer 2**

**5.1.1.4.1 MAC layer**

The MAC sublayer is responsible for the handling of the data streams coming from the RLC and RRC sublayers. It provides an unacknowledged transfer mode service to the upper layers. The interface to the RLC sublayer is through logical channel service access points. It also reallocates radio resources on request by the RRC sublayer as well as provides measurements to the upper layers. The logical channels are divided into control channels and traffic channels. Thus, the functionality handles issues like:

- mapping of the different logical channels to the appropriate transport channels and selection of appropriate transport format for the transport channels based on the instantaneous source bit rate. It also performs the multiplexing /demultiplexing of the PDUs to/from transport blocks which are thereafter further treated by the physical layer;
- performs dynamic switching between common and dedicated transport channels based on information from the RRC sublayer;
- handles priority issues for services to one UE according to information from higher layers and physical layer (e.g. available transmit power level) as well as priority handling between UEs by means of dynamic scheduling in order to increase spectrum efficiency;
- monitor traffic volume that can be used by the RRC sublayer.

Figure 12 shows the possibilities of mapping the logical channel DTCH (dedicated traffic channel) onto transport channels. There are possibilities to map onto shared transport channels as well as dedicated transport channels. The choice of mapping could be determined on e.g. amount of traffic a user creates.

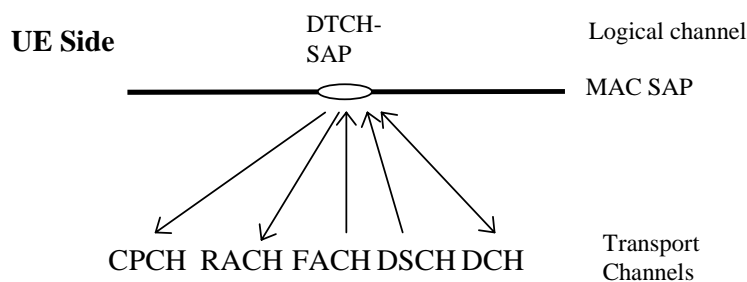

FIGURE 12

**The possible transport channel mappings of the dedicated traffic channel (DTCH)  
 (The arrows show the direction of the channel (UE side).  
 The directions are reversed from the network side)**

**5.1.1.4.2 RLC sublayer**

The RLC sublayer provides three different types of data transfer modes:

- **Transparent data transfer.** This service transmits higher layer PDUs without adding any protocol information, possibly including segmentation/reassemble functionality.
- **Unacknowledged data transfer.** This service transmits higher layer PDUs without guaranteeing delivery to the peer entity. The unacknowledged data transfer mode has the following characteristics:
  - a) detection of erroneous data: The RLC sublayer shall deliver only those SDUs to the receiving higher layer that are free of transmission errors by using the sequence-number check function;
  - b) unique delivery: The RLC sublayer shall deliver each SDU only once to the receiving upper layer using duplication detection function;
  - c) immediate delivery: The receiving RLC sublayer entity shall deliver a SDU to the higher layer receiving entity as soon as it arrives at the receiver.
- **Acknowledged data transfer.** This service transmits higher layer PDUs and guarantees delivery to the peer entity. In case RLC is unable to deliver the data correctly, the user of RLC at the transmitting side is notified. For this service, both in-sequence and out-of-sequence delivery are supported. In many cases a higher layer protocol can restore the order of its PDUs. As long as the out-of-sequence properties of the lower layer are known and controlled (i.e. the higher layer protocol will not immediately request retransmission of a missing PDU) allowing out-of-sequence delivery can save memory space in the receiving RLC. The acknowledged data transfer mode has the following characteristics:
  - a) error-free delivery: Error-free delivery is ensured by means of retransmission. The receiving RLC entity delivers only error-free SDUs to the higher layer;
  - b) unique delivery: The RLC sublayer shall deliver each SDU only once to the receiving upper layer using duplication detection function;
  - c) in-sequence delivery: RLC sublayer shall provide support for in-order delivery of SDUs, i.e. RLC sublayer should deliver SDUs to the receiving higher layer entity in the same order as the transmitting higher layer entity submits them to the RLC sublayer;
  - d) out-of-sequence delivery: Alternatively to in-sequence delivery, it shall also be possible to allow that the receiving RLC entity delivers SDUs to higher layer in different order than submitted to RLC sublayer at the transmitting side.

It also provides for RLC connection establishment/release. As well as QoS setting and notification to higher layers in case of unrecoverable errors.

An example of the data flow for non-transparent (acknowledged/unacknowledged) data transfer is shown in Figure 5.

#### **5.1.1.4.3 PDCP Sublayer**

PDCP provides transmission and reception of Network PDUs in acknowledged, unacknowledged and transparent RLC mode.

It is responsible for the mapping of Network PDUs from one network protocol to one RLC entity and it provides compression in the transmitting entity and decompression in the receiving entity of redundant Network PDU control information (header compression/ decompression).

#### **5.1.1.4.4 BMC Sublayer**

The BMC provides a broadcast/multicast transmission service in the user plane on the radio interface for common user data in transparent or unacknowledged mode.

[It can handle functionalities such as storage, scheduling and transmission of BMC messages.](#)

#### 5.1.1.5 Layer 3 (Radio resource control sublayer)

The Radio Resource Control (RRC) sublayer handles the control plane signalling of Layer 3 between the UEs and the radio interface. In addition to the relation with the upper layers (such as core network) the following main functions are performed:

- **Broadcast of information provided by the non-access stratum (Core Network).** The RRC layer performs system information broadcasting from the network to all UEs. The system information is normally repeated on a regular basis. This function supports broadcast of higher layer (above RRC) information. This information may be cell specific or not. As an example RRC may broadcast Core Network location service area information related to some specific cells.
- **Broadcast of information related to the access stratum.** The RRC layer performs system information broadcasting from the network to all UEs. This function supports broadcast of typically cell-specific information.
- **Establishment, maintenance and release of an RRC connection between the UE and the radio access network.** The establishment of an RRC connection is initiated by a request from higher layers at the UE side to establish the first Signalling Connection for the UE. The establishment of an RRC connection includes an optional cell re-selection, an admission control, and a layer 2 signalling link establishment.
- **Establishment, reconfiguration and release of Radio Access Bearers.** The RRC layer will, on request from higher layers, perform the establishment, reconfiguration and release of radio access bearers in the user plane. A number of radio access bearers can be established to an UE at the same time. At establishment and reconfiguration, the RRC layer performs admission control and selects parameters describing the radio access bearer processing in layer 2 and layer 1, based on information from higher layers.
- **Assignment, reconfiguration and release of radio resources for the RRC connection.** The RRC layer handles the assignment of radio resources (e.g. codes) needed for the RRC connection including needs from both the control and user plane. The RRC layer may reconfigure radio resources during an established RRC connection. This function includes co-ordination of the radio resource allocation between multiple radio bearers related to the same RRC connection. RRC controls the radio resources in the uplink and downlink such that UE and the radio access network can communicate using unbalanced radio resources (asymmetric uplink and downlink). RRC signals to the UE to indicate resource allocations for purposes of handover to GSM or other radio systems.
- **RRC connection mobility functions.** The RRC layer performs evaluation, decision and execution related to RRC connection mobility during an established RRC connection, such as handover, preparation of handover to GSM or other systems, cell re-selection and cell/paging area update procedures, based on e.g. measurements done by the UE.
- **Paging/notification.** The RRC layer can broadcast paging information from the network to selected UEs. The RRC layer can also initiate paging during an established RRC connection.
- **Control of requested QoS.** This function ensures that the QoS requested for the radio access bearers can be met. This includes the allocation of a sufficient number of radio resources.
- **UE measurement reporting and control of the reporting.** The measurements performed by the UE are controlled by the RRC layer, in terms of what to measure, when to measure

and how to report, including both this radio interface and other systems. The RRC layer also performs the reporting of the measurements from the UE to the network.

- **Outer loop power control.** The RRC layer controls setting of the target of the closed loop power control.
- **Control of ciphering.** The RRC layer provides procedures for setting of ciphering (on/off) between the UE and the radio access network.
- **Initial cell selection and re-selection in idle mode.** Selection of the most suitable cell based on idle mode measurements and cell selection criteria.
- **Arbitration of the radio resource allocation between the cells.** This function shall ensure optimal performance of the overall radio access network capacity.

#### 5.1.1.6 Summary of major technical parameters

Parameter	"Value"	Reference to Section 5.1.2
Multiple access technique and duplexing scheme	Multiple Access: Direct Sequence-CDMA Duplexing: FDD	5.1.2.1.1
Chip rate	3.84 Mcps	5.1.2.1.4
Frame length and structure	Frame length: 10 ms 15 slots per frame, each 666.666 $\mu$ s	5.1.2.1.2
Occupied bandwidth	Less than 5 MHz	5.1.2.4.1, 5.1.2.4.3
Adjacent Channel Leakage power ratio (transmitter side)	UE (UE Power Class: + 21 dBm <u>and</u> <u>+24 dBm</u> ):  ACLR (5 MHz) = 33 dB ACLR (10 MHz) = 43 dB BS: ACLR (5 MHz) = 45 dB ACLR (10 MHz) = 50 dB	5.1.2.4.1  5.1.2.4.3
Adjacent channel selectivity (receiver side)	UE: ACS (5 MHz) = 33 dB BS: ACS (5 MHz) = 45 dB	5.1.2.4.1 5.1.2.4.3
Random access mechanism	Acquisition indication based random-access mechanism with power ramping on preamble followed by message	5.1.2.1.2 5.1.2.1.5
Pilot structure	Uplink: Dedicated pilots Downlink: Common and/or dedicated pilots	5.1.2.1.2
Inter base station asynchronous/synchronous operation	Asynchronous; Synchronous (Optional)	5.1.2.1.5 5.1.2.4.3



## 5.3 IMT-2000 CDMA TDD

### 5.3.1 Overview of the radio interface

#### 5.3.1.1 Introduction

The IMT-2000 radio interface specifications for CDMA TDD technology are developed by a partnership of standards development organizations (SDOs)<sup>6</sup> and CWTS. This radio interface is called the Universal Terrestrial Radio Access (UTRA) Time Division Duplex (TDD), and TD-SCDMA (Time Division-Synchronous Code Division Multiple Access), where TD-SCDMA is also referred to as the UTRA TDD Low chip rate 1.28 Mcps TDD option and UTRA TDD represents the 3.84 Mcps TDD-UTRA TDD High chip rate option. It is remarked that 3GPP UTRA physical layer specifications produced by TSG RAN WG1 adopt the following terminology: "1.28 Mcps TDD" to indicate the UTRA TDD low chip rate option and "3.84 Mcps TDD" to indicate the UTRA TDD high chip rate option.

The UTRA TDD specifications have been developed with the strong objective of harmonization with the FDD component (see Section 5.1) to achieve maximum commonality. This was achieved by harmonization of important parameters of the physical layer and a common set of protocols in the higher layers are specified for both FDD and TDD. The TD-SCDMA specifications were originally developed in China and introduced by CWTS. TD-SCDMA has significant commonality with UTRA TDD. Within the current specifications, capabilities are included to enable introduction of TD-SCDMA properties into a joint UTRA TDD concept and to allow the on-going process to optimize the integration of the two TDD technologies options. The joint UTRA TDD concept with the two options (Low chip rate 1.28 Mcps TDD and High chip rate 3.84 Mcps TDD) will accommodate the various needs of the different Regions in a flexible way. The reference sections illustrate the current state of the specification processes<sup>7</sup>.

In the development of this radio interface the core network specifications are based on an evolved GSM-MAP, but the specifications include the necessary capabilities for operation with an evolved ANSI-41 based core network.

The radio access scheme is direct-sequence code division multiple access. There are two chip rate ~~versions~~ options: UTRA TDD the high chip rate 3.84 Mcps TDD option, with information spread over approximately 5 MHz bandwidth and a chip rate of 3.84 Mcps and TD-SCDMA the low chip rate 1.28 Mcps TDD option, with information spread over approximately 1.6 MHz bandwidth and a chip rate of 1.28 Mcps. The radio interface is defined to carry a wide range of services to efficiently support both circuit-switched services (e.g. PSTN- and ISDN-based networks) as well as packet-switched services (e.g. IP-based networks). A flexible radio protocol has been designed where several different services such as speech, data, multimedia can simultaneously be used by a user and multiplexed on a single carrier. The defined radio bearer services provide for both real-time and non-real time services support by employing transparent and/or non-transparent data transport. The quality of service can be adjusted in terms such as delay, bit error ratio, frame error ratio.

---

<sup>6</sup> Currently, these specifications are developed within the Third Generation Partnership Project (3GPP) where the participating SDOs are ARIC, CWTS, ETSI, T1, TTA and TTC.

<sup>7</sup> It is anticipated that following further harmonization An initiatives is running in 3GPP with the goal to integrate TD-SCDMA as the "Low chip rate TDD option" 1.28 Mcps TDD option of a harmonized joint UTRA TDD conceptsolution will be developed in 3GPP. A specific Work Item for Release 2000 called "Low-chip-rate TDD option" was approved in 3GPP TSG RAN and work is on going.

### 5.3.1.2 Radio Access Network Architecture

The overall architecture of the system is shown in Figure 24. Note: Macrodiversity (as indicated in the figure) is not necessary in TDD due to the TDMA component, and has not been included in the current specifications.

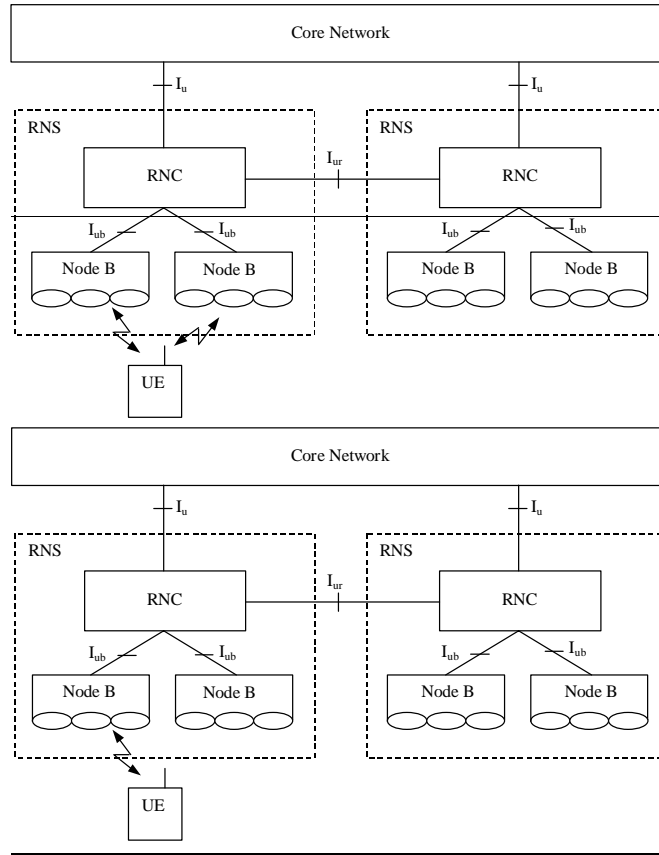

FIGURE 24

#### Radio Access Network Architecture (Cells are indicated by ellipses)

The architecture of this radio interface consists of a set of Radio Network Subsystems (RNS) connected to the Core Network through the  $I_u$  interface.

A RNS consists of a Radio Network Controller (RNC) and one or more entities called Node B. Node B are connected to the RNC through the  $I_{ub}$  interface. Node B can handle one or more cells.

The RNC is responsible for the handover decisions that require signalling to the User Equipment (UE).

~~Inside the radio interface,~~ The RNCs of the Radio Network Subsystems can be interconnected together through the  $I_{ur}$ . The  $I_u$  and  $I_{ur}$  are logical interfaces.  $I_{ur}$  can be conveyed over physical direct connection between RNCs or via any suitable transport network.

Figure 25 shows the radio interface protocol architecture for the radio access network. On a general level, the protocol architecture is similar to the current ITU-R protocol architecture as described in Recommendation ITU-R M.1035. Layer 2 (L2) is split into the following two sublayers: Radio Link Control (RLC), and Medium Access Control (MAC), Packet Data Convergence Protocol (PDCP) and Broadcast/Multicast Control (BMC). Layer 3 (L3) and RLC are divided into Control (C-) and User (U-) planes.

In the C-plane, L3 is partitioned into sublayers where the lowest sublayer, denoted as Radio Resource Control (RRC), interfaces with L2. The higher layer signalling such as Mobility Management (MM) and Call Control (CC) are assumed to belong to the core network. There are no L3 elements in UTRAN for the U-plane.

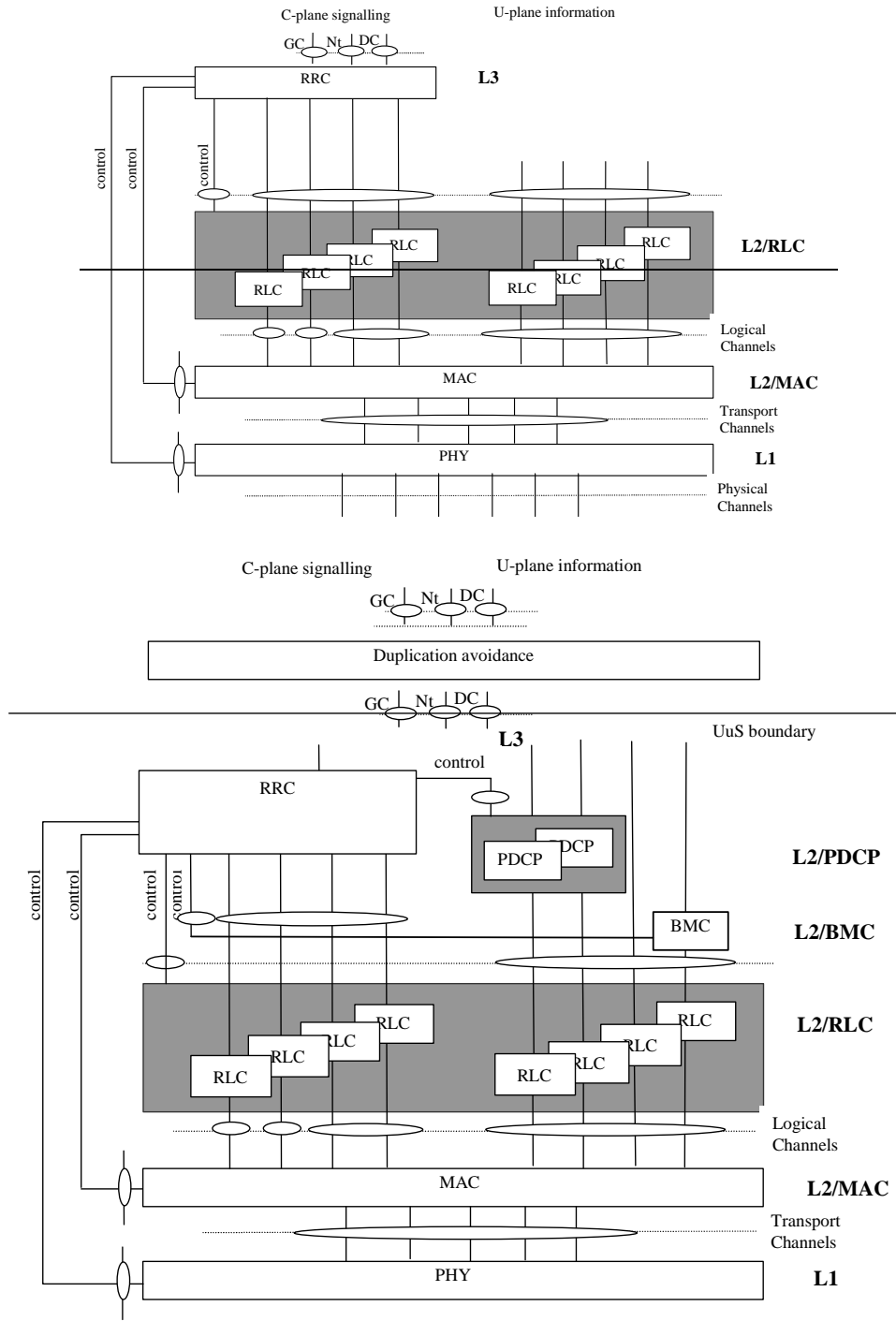

FIGURE 25

**Radio interface protocol architecture of the RRC sublayer,  
(L2 and L1)**

Each block in Figure 25 represents an instance of the respective protocol. Service Access Points (SAP) for peer-to-peer communication are marked with circles at the interface between sublayers. The SAPs between RLC and the MAC sublayer provide the logical channels. The type of information transferred characterizes a logical channel. The logical channels are divided into control channels and traffic channels. The different types are not further described in this overview. The SAP between MAC and the physical layer provides the transport channels. A transport channel is characterized by how the information is transferred over the radio interface, see Section 5.3.1.3 for an overview of the types defined. The physical layer generates the physical channels that will be transmitted over the air. The physical channel is defined by carrier frequency, code, time slot and multi-frame information. In the C-plane, the interface between RRC and higher L3 sublayers (CC, MM) is defined by the General Control (GC), Notification (Nt) and Dedicated Control (DC) SAPs. These SAPs are not further discussed in this overview.

Also shown in the figure are connections between RRC and MAC as well as RRC and L1 providing local inter-layer control services (including measurement results). An equivalent control interface exists between RRC and the RLC sublayer. These interfaces allow the RRC to control the configuration of the lower layers. For this purpose separate Control SAPs are defined between RRC and each lower layer (RLC, MAC, and L1).

Figure 26 shows the general structure and some additional terminology definitions of the channel formats at the various sublayer interfaces indicated in Figure 25. The figure indicates how higher layer Service data Units (SDU) and Protocol Data Units (PDUs) are segmented and multiplexed to transport blocks to be further treated by the physical layer. The transmission chain of the physical layer is described in the next section.

~~Opportunity Driven Multiple Access (ODMA) operates on relay links between different Relays. These Relays may be represented by either UEs with ODMA capability or ODMA seeds (ODMA equipment permanently located in the network). Relays/Seeds may act as gateways to connect the ODMA equipment to the radio interface. This can be done using either this radio interface or the radio interface in Section 5.1.~~

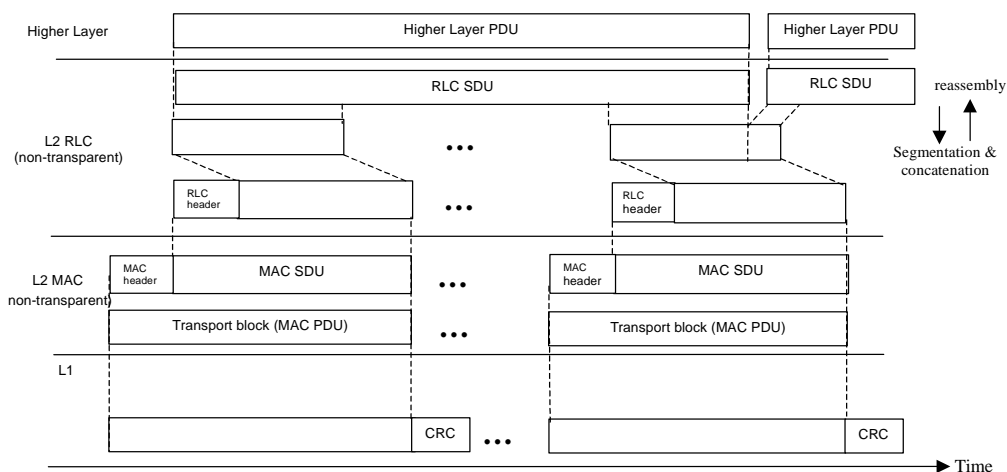

FIGURE 26

**Data flow for a service using a non-transparent RLC and non-transparent MAC (see Sections 5.3.1.4.1-2 for further definitions of the MAC and RLC services and functionality)**

### 5.3.1.3 Physical layer

#### 5.3.1.3.1 UTRA TDD (~~high chip rate~~ 3.84 Mcps TDD option)

##### 5.3.1.3.1.1 Physical layer functionality and building blocks

The physical layer includes the following functionality:

- Error detection on transport channels and indication to higher layers.
- Forward Error Control (FEC) encoding/decoding of transport channels.
- Multiplexing of transport channels and demultiplexing of coded composite transport channels.
- Rate matching (data multiplexed on Dedicated and Shared Channels).
- Mapping of coded composite transport channels on physical channels.
- Power weighting and combining of physical channels.
- Modulation and spreading/demodulation and despreading of physical channels.
- Frequency and time (chip, bit, slot, frame) synchronization.
- Radio characteristics measurements including Frame Error Rate (FER), Signal-to-Interference (SIR), Interference Power Level etc., and indication to higher layers.
- Closed-loop power control.
- Radio Frequency (RF) processing.
- Support of Timing Advance on uplink channels.

Figure 27 gives the physical layer transmission chain for the user plane data, i.e. from the level of transport channels down to the level of physical channel. The figure shows how several transport channels can be multiplexed onto one or more dedicated physical data channels (DPDCH).

The cyclic redundancy check (CRC) provides for error detection of the transport blocks for the particular transport channel. The CRC can take the length zero (no CRC), 8, 16 or 24 bits depending on the service requirements.

The transport block concatenation and code block segmentation functionality performs serial concatenation of those transport blocks that will be sent in one transport time interval and any code block segmentation if necessary.

The types of channel coding defined are convolutional coding, turbo coding and no coding. Real-time services use only FEC encoding while non real-time services uses a combination of FEC and ARQ. The ARQ functionality resides in the RLC layer of Layer 2. The convolutional coding rates are 1/2 or 1/3 while the rate is 1/3 for turbo codes.

The possible interleaving depths are 10, 20, 40 or 80 milliseconds.

The radio frame segmentation performs padding of bits. The rate matching adapts any remaining differences of the bit rate so the number of outgoing bits fit to the available bit rates of the physical channels. Repetition coding and/or puncturing is used for this purpose.

The TrCH multiplexing stage combines transport channels in a serial fashion. This is done every 10 milliseconds. The output of this operation is also called coded composite transport channels.

If several physical channels will be used to transmit the data, the split is made in the physical channel segmentation unit.

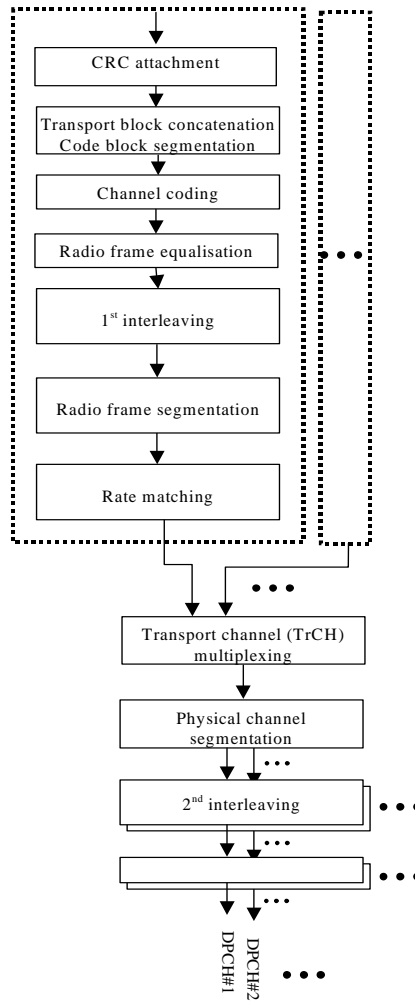

FIGURE 27

### Transport channel multiplexing structure

#### 5.3.1.3.1.2 Transport channels

The interface to the MAC layer is the transport channels, see Figure 25. The transport channels define how and with which type of characteristics the data is transferred by the physical layer. They are categorized into dedicated channels or common channels where many UEs are sharing the latter type. Introducing an information field containing the address then does the address resolution, if needed. The physical channel itself defines a dedicated channel. Thus no specific address is needed for the UE. Table 2 summarizes the different types of available transport channels.

TABLE 2

**The defined transport channels**

<b>Transport channel</b>	<b>Type and direction</b>	<b>Used for</b>
DCH (Dedicated channel)	Dedicated; uplink and downlink	User or control information to a UE (entire cell or part of cell (lobe-forming))
BCH (Broadcast channel)	Common; downlink	Broadcast system and cell specific information
FACH (Forward access channel)	Common; downlink	Control information when system knows UE location or short user packets to a UE
PCH (Paging channel)	Common; downlink	Control information to UEs when good sleep mode properties are needed, e.g. idle mode operation
RACH (Random access channel)	Common; uplink	Control information or short user packets from an UE
USCH (Uplink shared channel)	Common; Uplink	TDD only. Carries dedicated user data and control information using a shared channel
<del>ODCH (ODMA Dedicated channel)</del>	<del>Dedicated</del>	<del>TDD only. Applicable for ODMA relaying</del>
<del>ORACH (ODMA Random Access Channel)</del>	<del>Common</del>	<del>TDD only. Applicable for ODMA relaying</del>
DSCH (Downlink shared channel)	Common; downlink	Carries dedicated user data and control information using a shared channel.

The random access channel on the uplink is contention-based while the dedicated channel is reservation-based.

**5.3.1.3.1.3 Transport channels to Physical channel mapping**

The transport channels are mapped onto the physical channels and Figure 28 show the different physical channels and summarizes the mapping of transport channels onto physical channels. Each physical channel has its tailored slot content. The dedicated channel (DCH) is shown in Section 5.3.1.3.1.4.

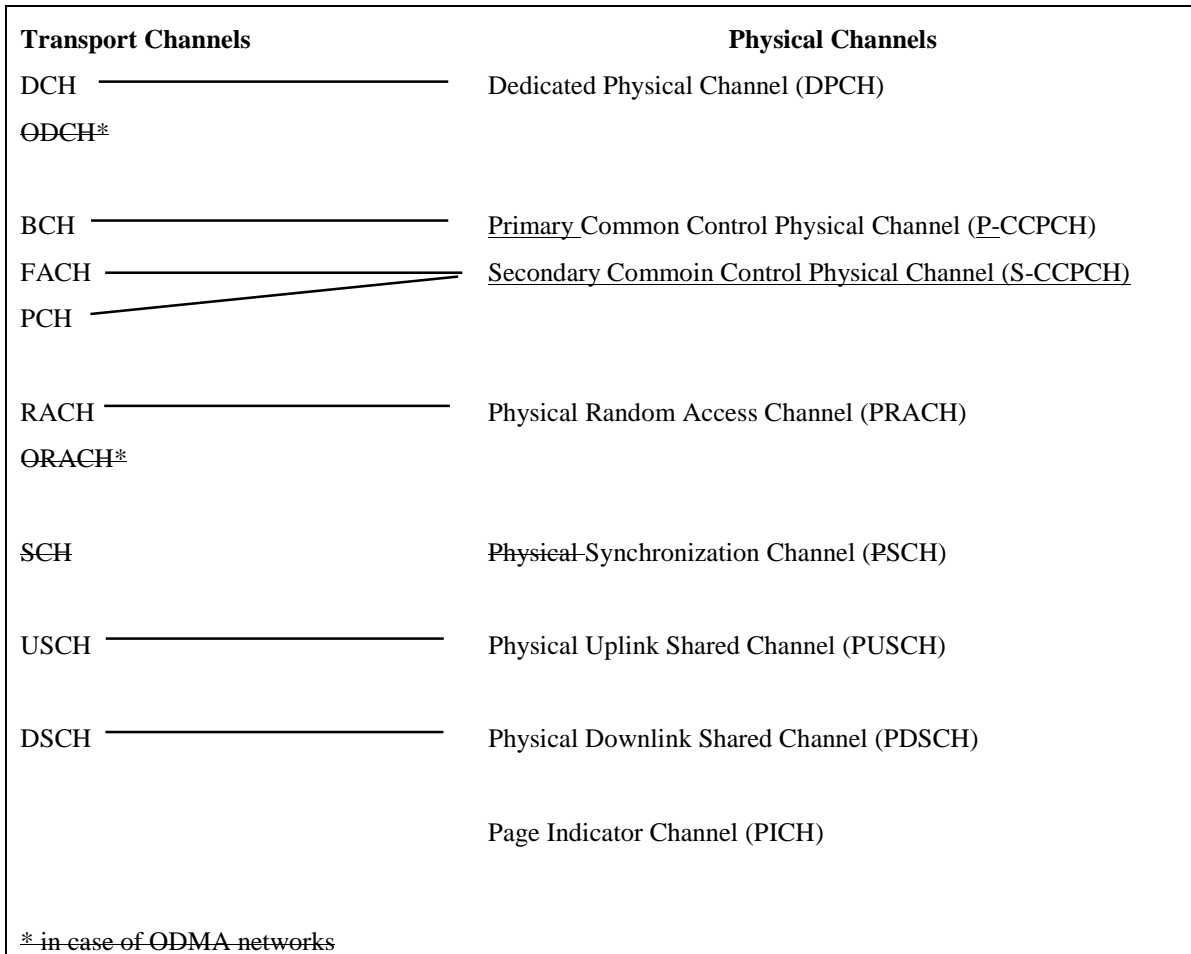
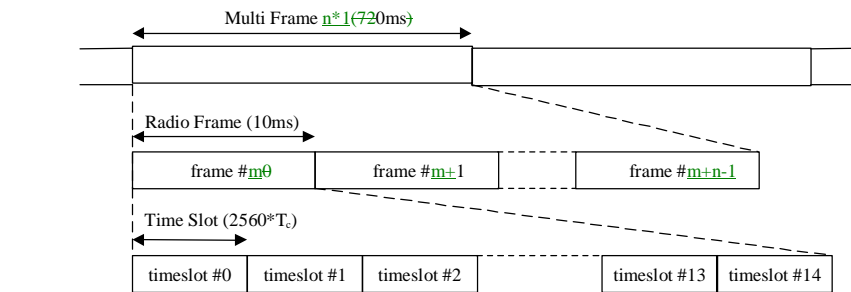

FIGURE 28

**Transport channels, physical channels and their mapping**

**5.3.1.3.1.4 Physical frame structure**

The basic physical frame rate is 10 milliseconds with 15 slots. Figure 29 shows the frame structure.





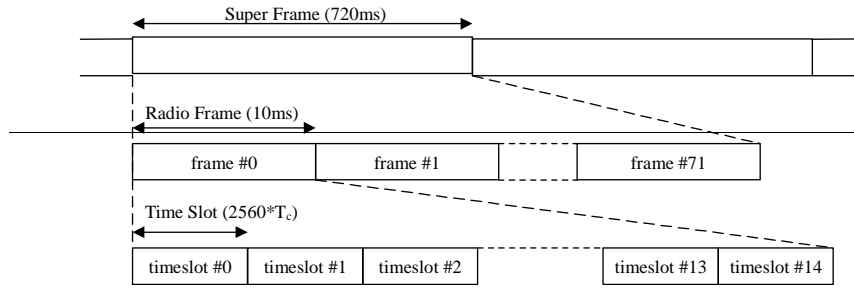

FIGURE 29

**Basic frame structure—TDD**

Each 10 ms frame consists of 15 time slots, each allocated to either the uplink or the downlink. With such a flexibility, this radio interface can be adapted to different environments and deployment scenarios. In any configuration at least one time slot has to be allocated for the downlink and at least one time slot has to be allocated for the uplink.

~~When operating ODMA at least one common timeslot has to be allocated for the ORACH. If large quantities of information have to be transferred between ODMA nodes then it is normal to use at least one timeslot for the ODCH (Figure 30).~~

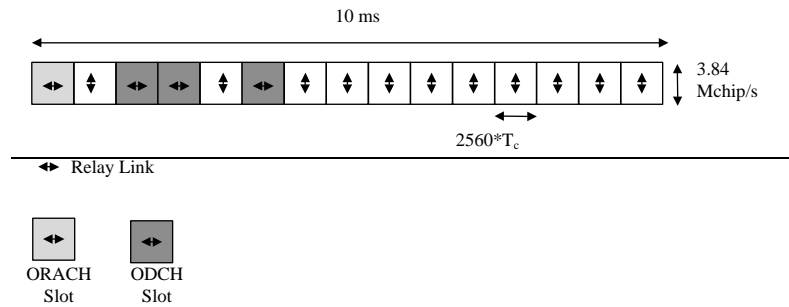

FIGURE 30

**~~TDD frame structure example for ODMA operation~~**

Figure 31 and Figure 32 show the two burst formats stating the content for a slot used by a DCH. The usage of either burst format 1 or 2 is depending on the application for UL or DL and the number of allocated users per timeslot.

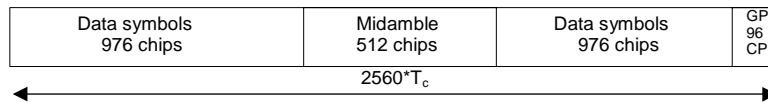

FIGURE 31

**Burst structure of the burst type 1  
(GP denotes the guard period and CP the chip periods)**

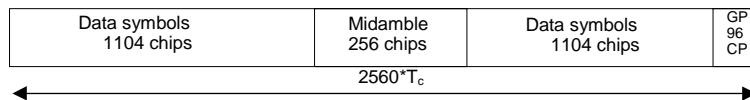

FIGURE 32

**Burst structure of the burst type 2  
(GP denotes the guard period and CP the chip periods)**

In both cases data bits are QPSK modulated and the resulting symbols are spread with a channelization code of length 1 to 16 (for the DL, only 1 and 16 apply). Due to this variable spreading factor, each data part of one burst provides the number of symbols as shown in Table 3 below.

TABLE 3

**Number of data symbols in TDD bursts ~~in high chip rate~~ 3.84 Mcps TDD option**

Spreading factor (Q)	Number of symbols (N) per data field in Burst 1	Number of symbols (N) per data field in Burst 2
1	976	1104
2	488	552
4	244	276
8	122	138
16	61	69

Thus, the number of bits per TDD burst ~~in the high chip rate~~ 3.84 Mcps TDD option is four times the number shown in Table 3. Usage of multicode and multiple timeslots can be applied.

#### 5.3.1.3.1.5 Spreading, modulation and pulse shaping

Spreading is applied after modulation and before pulse shaping. It consists of two operations. The first is the channelization operation, which transforms every data symbol into a number of chips, thus increasing the bandwidth of the signal. The number of chips per data symbol is called the Spreading Factor (SF) and is in the range of 1 to 16. The second operation is the scrambling operation, where a scrambling code is applied to the spread signal. This procedure is similar to the radio interface specified in Section 5.1, but it should be noted that the midamble part in TDD bursts (see Figure 31 and Figure 32) is not spread.

The applied channelization codes are OVVSF-codes (Orthogonal Variable Spreading Factor-codes) that preserve the distinguishability of different users. The applied scrambling code is cell-specific and 128 different scrambling codes are available.

In the Uplink, the applied midamble is user specific and derived from a cell-specific Basic Midamble Sequence. In the Downlink, the applied midamble is either user specific or common for the whole cell. In each case 128 different Basic Midamble sequences are available.

After spreading same pulse-shaping is applied as in FDD Mode, i.e. the filters are root-raised cosine with roll-off  $\alpha=0.22$  in the frequency domain.

#### 5.3.1.3.2 TD-SCDMA

##### 5.3.1.3.2.1 Physical layer functionality and building blocks

The physical layer includes the following functionality:

- FEC encoding/decoding of transport channels
- Macrodiversity distribution/combining and handover execution
- Multiplexing/demultiplexing of transport channels and of coded composite transport channels
- Subframe segmentation
- Mapping of coded composite transport channels on physical channels

- Modulation and spreading/demodulation and despreading of physical channels

- Frequency and time (chip, bit, time slot, subframe) synchronization
- Power control
- Random access process
- Dynamic channel allocation (DCA)
- ~~ODMA specific procedures (optional)~~
  - Power weighting and combining of physical channels
  - RF processing
  - Error detection
  - Rate matching (data multiplexed on DCH)
  - Radio characteristics measurements including FER, SIR, DOA, timing advance, etc.
  - Handover measurements
  - Uplink synchronization
  - Beamforming for both uplink and downlink (Smart antenna)
  - UE location/positioning (Smart antenna)

Figure 33 gives the physical layer transmission chain for the user plane data, i.e. from the level of transport channels down to the level of physical channel. The Figure 33 shows how several transport channels can be multiplexed onto one or more dedicated physical channels (DPCH). The cyclic redundancy check (CRC) provides for error detection of the transport blocks for the particular transport channel. The CRC can take the length zero (no CRC), 8, 16 or 24 bits depending on the service requirements.

The transport block concatenation and code block segmentation functionality performs serial concatenation of those transport blocks that will be sent in one transport time interval and any code block segmentation if necessary.

The types of channel coding defined are convolutional coding, turbo coding and no coding. Real-time services use only FEC encoding while non real-time services uses a combination of FEC and ARQ. The ARQ functionality resides in the RLC layer of Layer 2. The convolutional coding rates are 1/2 or 1/3 while the rate is 1/3 for turbo codes.

The possible interleaving depths are 10, 20, 40 or 80 milliseconds.

The radio frame equalization performs padding of bits. The rate matching adapts any remaining differences of the bit rate so the number of outgoing bits fit to the available bit rates of the physical channels. Repetition coding and/or puncturing is used for this purpose.

The TrCH multiplexing stage combines transport channels in a serial fashion. This is done every 10 milliseconds. The output of this operation is also called coded composite transport channels.

If several physical channels will be used to transmit the data, the split is made in the physical channel segmentation unit.

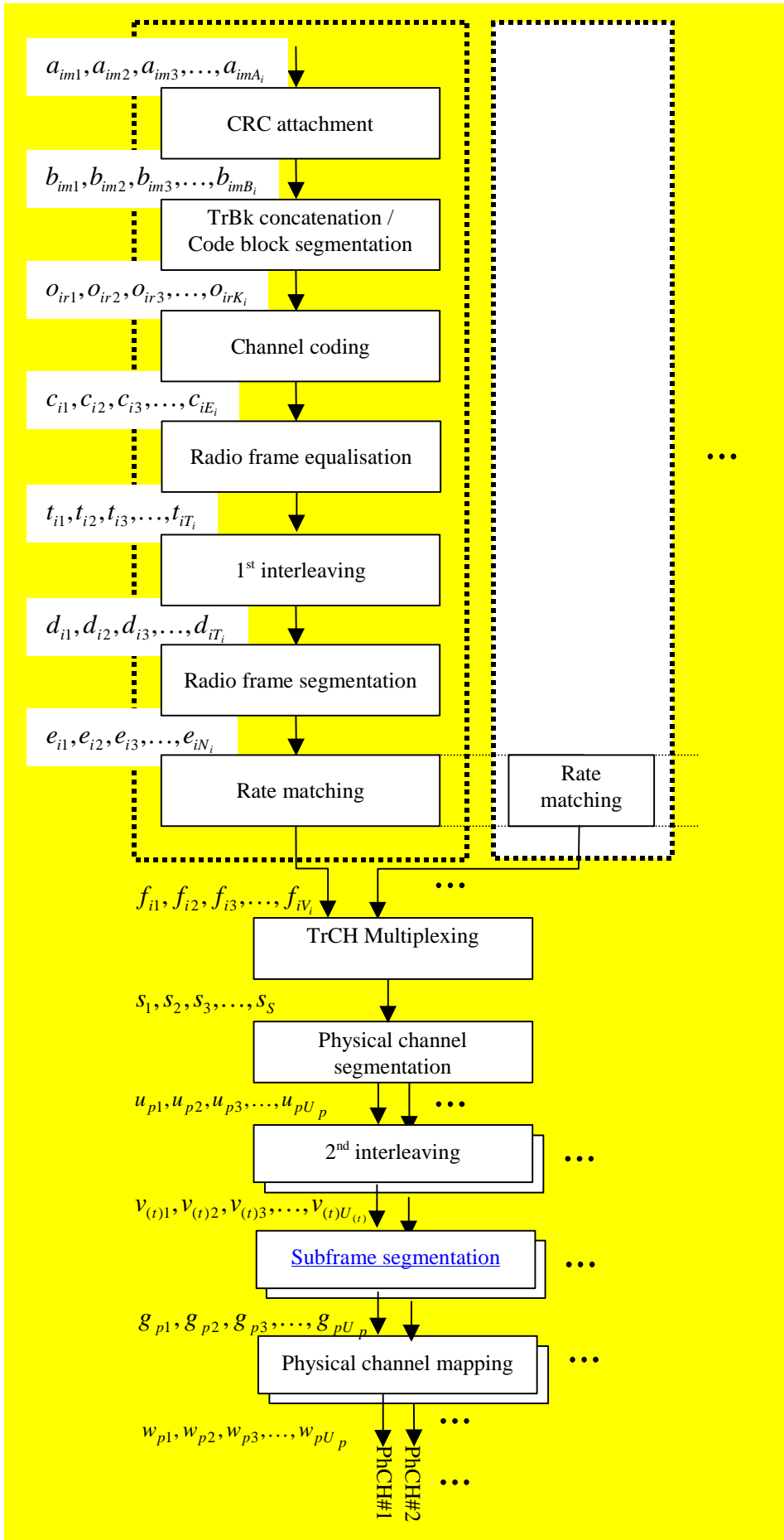

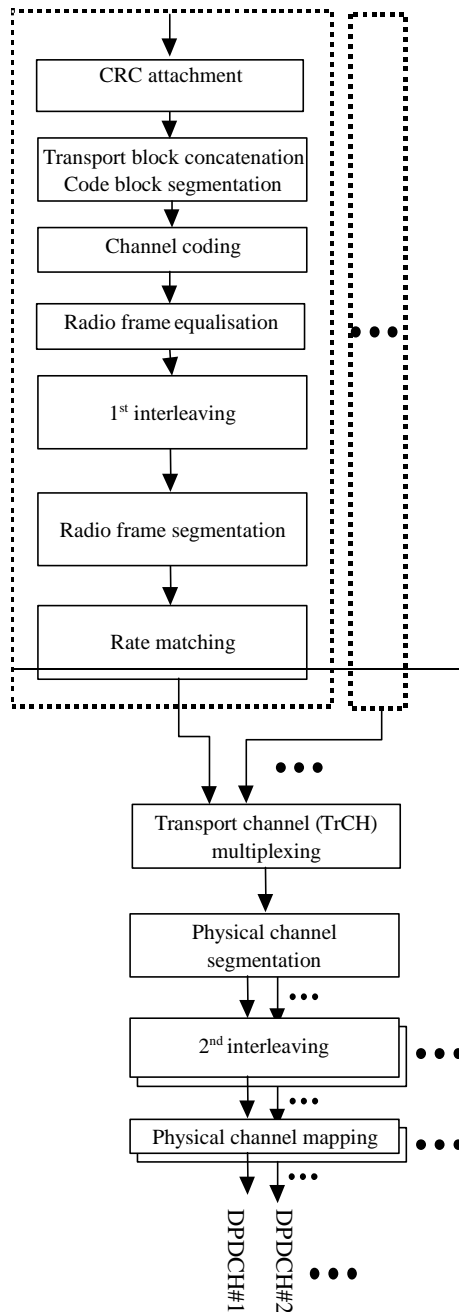

FIGURE 33

**Transport channel multiplexing structure-(TD-SCDMA)**

**5.3.1.3.2.2 Transport channels**

The interface to the MAC layer is the transport channels, see Figure 25. The transport channels define how and with which type of characteristics the data is transferred by the physical layer. They are categorized into dedicated channels or common channels where many UEs are sharing the latter type. Introducing an information field containing the address then does the address resolution, if needed. The physical channel itself defines a dedicated channel. Thus no specific address is needed for the UE. Table 4 summarizes the different types of available transport channels.

TABLE 4

**The defined transport channels**

<b>Transport channel</b>	<b>Type and direction</b>	<b>Used for</b>
DCH (Dedicated channel)	Dedicated; uplink and downlink	User or control information to a UE (entire cell or part of cell (lobe-forming))
BCH (Broadcast channel)	Common; downlink	Broadcast system and cell specific information
FACH (Forward access channel)	Common; downlink	Control information when system knows UE location or short user packets to a UE
PCH (Paging channel)	Common; downlink	Control information to UEs when good sleep mode properties are needed, e.g. idle mode operation
RACH (Random access channel)	Common; uplink	Control information or short user packets from an UE
SCH (Pilot and Synchronization channel)	Common; uplink and downlink	Transmit uplink/downlink pilot sequence and synchronization codes
<del>ODCH* (ODMA-Dedicated channel)</del>	<del>Dedicated</del>	<del>Applicable for ODMA relaying</del>
<del>ORACH* (ODMA-Random Access Channel)</del>	<del>Common</del>	<del>Applicable for ODMA relaying</del>
DSCH (Downlink shared channel)	Common; downlink	Carries dedicated user data and control information using a shared channel.
USCH (Uplink shared channel)	Common; Uplink	Carries dedicated user data and control information using a shared channel
*:- <del>item which is an option</del>		

The random access channel on the uplink is contention-based while the dedicated channel is reservation-based.

**5.3.1.3.2.3 Transport channels to physical channel mapping**

The transport channels are mapped onto the physical channels and Figure 34 shows the different physical channels and summarizes the mapping of transport channels onto physical channels. Each physical channel has its tailored slot content. The dedicated channel (DCH) is shown in section 5.3.1.3.2.4.



<u>Transport channels</u>	<u>Physical channels</u>
<u>DCH</u>	<u>Dedicated Physical Channel (DPCH)</u>
<u>BCH</u>	<u>Primary Common Control Physical Channels (P-CCPCH)</u>
<u>PCH</u>	<u>Primary Common Control Physical Channels (P-CCPCH)</u> <u>Secondary Common Control Physical Channels(S-CCPCH)</u>
<u>FACH</u>	<u>Primary Common Control Physical Channels (P-CCPCH)</u> <u>Secondary Common Control Physical Channels(S-CCPCH)</u>
<u>RACH</u>	<u>Physical Random Access Channel (PRACH)</u>
<u>USCH</u>	<u>Physical Uplink Shared Channel (PUSCH)</u>
<u>DSCH</u>	<u>Physical Downlink Shared Channel (PDSCH)</u>
	<u>Down link Pilot Time Slot (DwPTS)</u>
	<u>Up link Pilot Time Slot (UpPTS)</u>
	<u>FPACH</u>

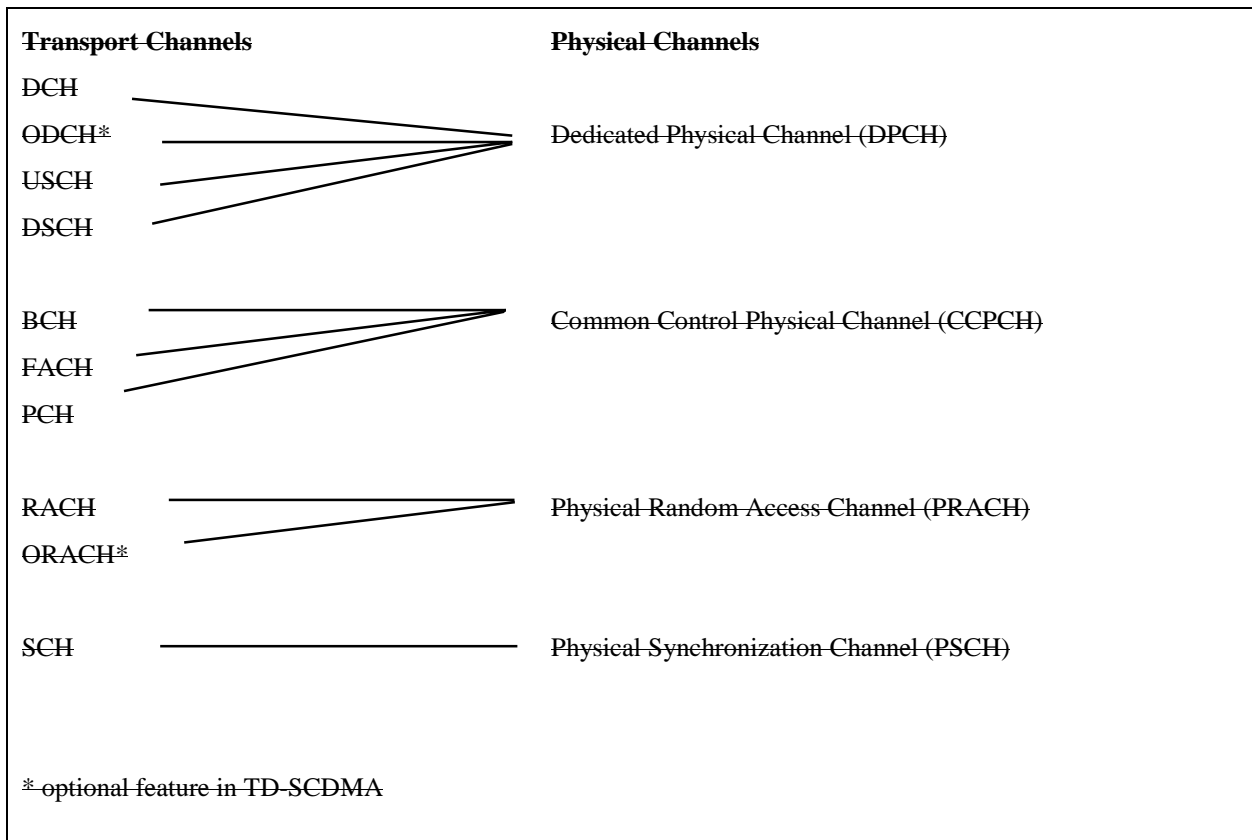
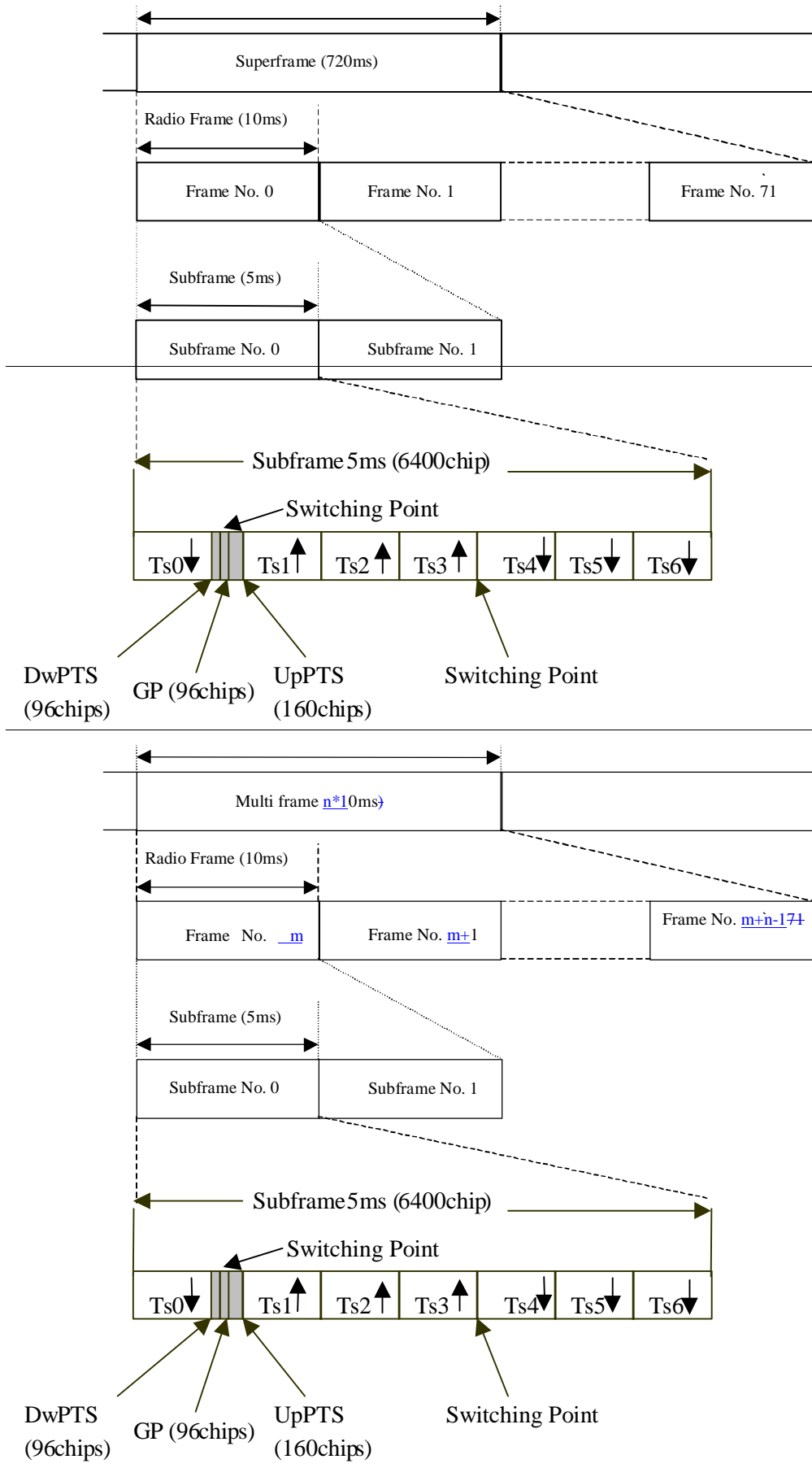

FIGURE 34

**Transport channel, physical channel and their mapping**

**5.3.1.3.2.4 Frame structure**

Physical channels take four-layer structure of super-frames, radio frames, sub-frames and time slots/codes as shown in Figure 35. One super frame has the length of 720 ms, which is composed by 72 radio frames. The radio frame has a duration of 10 ms and is subdivided into 2 sub-frames of 5 ms each, and each sub-frame is then subdivided into 7 main time slots (TS) of 675  $\mu$ s duration each and 3 special time slots: DwPTS (downlink pilot), G (guard period) and UpPTS (uplink pilot).



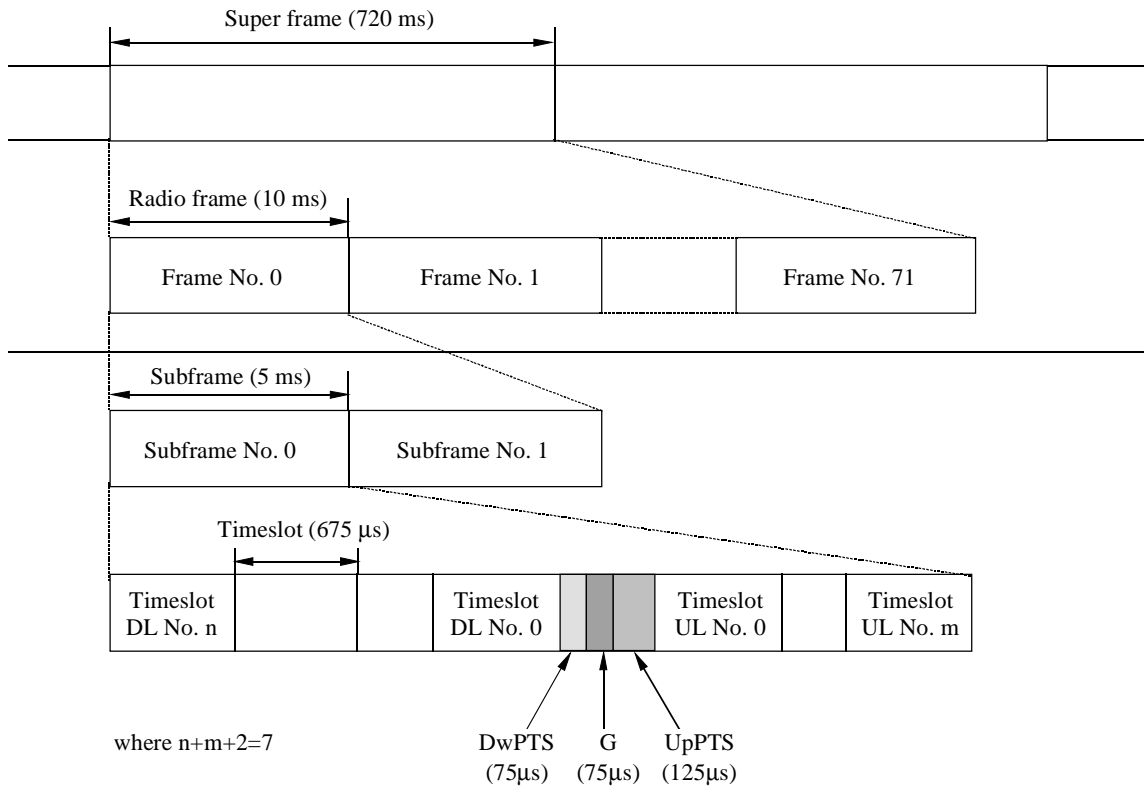

Temp 8/126-5.33

FIGURE 35  
Frame and burst structure

~~When operating ODMA at least one common timeslot has to be allocated for the ORACH. If large quantities of information have to be transferred between ODMA nodes then it is normal to use at least one timeslot for the ODCH (Figure 36).~~

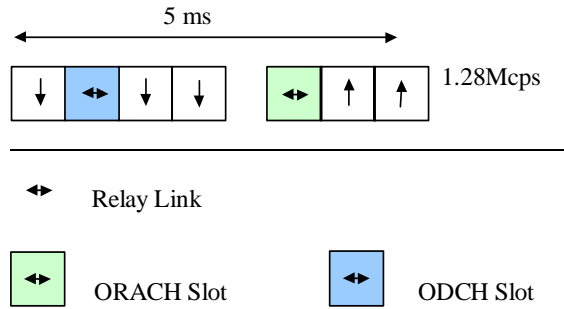

FIGURE 36

**Frame structure for ODMA operation**

The burst structure is shown in Figure 37. The burst type consist of two data symbol fields, a midamble of 144 chips and a guard period of 16 chips. The data fields of the burst type are 704 chips long. Data bits in the burst are QPSK modulated and are spread by the spreading factor of 1 to 16. The guard period for the burst type is 16 chips period long. 8PSK modulation may optionally be applied.

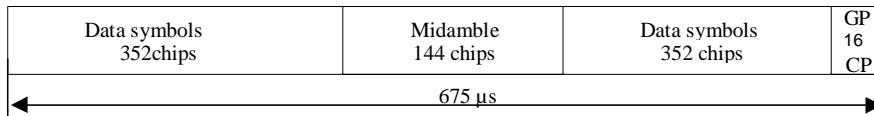

FIGURE 37

**Burst structure**

The corresponding number of symbols depends on the spreading factor as indicated in Table 5.

TABLE 5

**Number of data symbols in one burst with different SF**

Spreading factor (Q)	Number of symbols (N) per data field in Burst
1	352
2	176
4	88
8	44
16	22

### **5.3.1.3.2.5 Spreading, modulation and pulse shaping**

Spreading is applied after modulation and before pulse shaping. It consists of two operations. The first is the channelization operation, which transforms every data symbol into a number of chips, thus increasing the bandwidth of the signal. The number of chips per data symbol is called the Spreading Factor (SF) and is in the range of 1 to 16. The second operation is the scrambling operation, where a scrambling code is applied to the spread signal. It should be noted that the midamble part in TDD bursts is not spread.

The applied channelization codes are OVVSF-codes (Orthogonal Variable Spreading Factor-codes) that preserve the distinguishability of different users. The applied scrambling code is cell-specific.

In the Uplink, the applied midamble is user specific and derived from a cell-specific Basic Midamble Sequence. In the downlink, the applied midamble is either user specific or common for the whole cell.

After spreading, pulse-shaping is applied, i.e. the filters are root-raised cosine with roll-off  $\alpha=0.22$  in the frequency domain.

### **5.3.1.3.2.6 Transmission and reception**

The frequency bands assumed for operation are unpaired frequency bands at 2 GHz. Also system can work in other frequency bands available. Several Tx power classes for UE are being defined currently.

## **5.3.1.4 Layer 2**

### **5.3.1.4.1 Medium Access Control (MAC) layer**

The MAC sublayer is responsible for the handling of the data streams coming from the RLC and RRC sublayers. It provides an unacknowledged transfer mode service to the upper layers. The interface to the RLC sublayer is through logical channel service access points. It also reallocates radio resources on request by the RRC sublayer as well as provides measurements to the upper layers. The logical channels are divided into control channels and traffic channels. Thus, the functionality handles issues like:

- Mapping of the different logical channels to the appropriate transport channels and selection of appropriate transport format for the transport channels based on the instantaneous source bit rate. It also performs the multiplexing /demultiplexing of the PDUs to/from transport blocks which are thereafter further treated by the physical layer;
- performs dynamic switching between common and dedicated transport channels based on information from the RRC sublayer;
- handles priority issues for services to one UE according to information from higher layers and physical layer (e.g. available transmit power level) as well as priority handling between UEs by means of dynamic scheduling in order to increase spectrum efficiency;
- monitor traffic volume that can be used by the RRC sublayer;

Figure 38 shows the possibilities of mapping the logical channel DTCH (dedicated traffic channel) onto transport channels. There are possibilities to map onto shared transport channels as well as dedicated transport channels. The choice of mapping could be determined on e.g. amount of traffic a user creates.

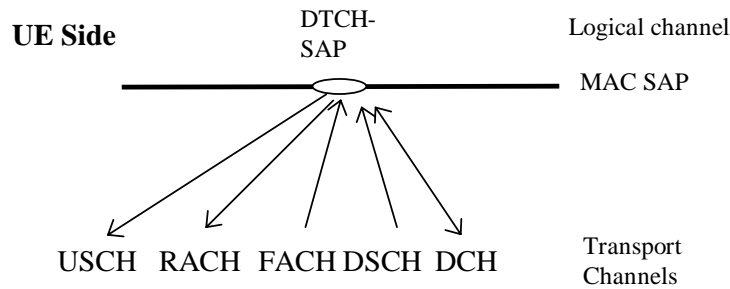

FIGURE 38

**The possible transport channel mappings of the dedicated traffic channel (DTCH)  
(The arrows shows the direction of the channel (UE side);  
the directions are reversed from the network side)**

#### 5.3.1.4.2 Radio Link Control (RLC) sublayer

The RLC sublayer provides three different types of data transfer modes:

- **Transparent data transfer.** This service transmits higher layer PDUs without adding any protocol information, possibly including segmentation/reassemble functionality.
- **Unacknowledged data transfer.** This service transmits higher layer PDUs without guaranteeing delivery to the peer entity. The unacknowledged data transfer mode has the following characteristics:
  - Detection of erroneous data: The RLC sublayer shall deliver only those SDUs to the receiving higher layer that are free of transmission errors by using the sequence-number check function.
  - Unique delivery: The RLC sublayer shall deliver each SDU only once to the receiving upper layer using duplication detection function.
  - Immediate delivery: The receiving RLC sublayer entity shall deliver a SDU to the higher layer receiving entity as soon as it arrives at the receiver.
- **Acknowledged data transfer.** This service transmits higher layer PDUs and guarantees delivery to the peer entity. In case RLC is unable to deliver the data correctly, the user of RLC at the transmitting side is notified. For this service, both in-sequence and out-of-sequence delivery are supported. In many cases a higher layer protocol can restore the order of its PDUs. As long as the out-of-sequence properties of the lower layer are known and controlled (i.e. the higher layer protocol will not immediately request retransmission of a missing PDU) allowing out-of-sequence delivery can save memory space in the receiving RLC. The acknowledged data transfer mode has the following characteristics:
  - Error-free delivery: Error-free delivery is ensured by means of retransmission. The receiving RLC entity delivers only error-free SDUs to the higher layer.
  - Unique delivery: The RLC sublayer shall deliver each SDU only once to the receiving upper layer using duplication detection function.
  - In-sequence delivery: RLC sublayer shall provide support for in-order delivery of SDUs, i.e. RLC sublayer should deliver SDUs to the receiving higher layer entity in the same order as the transmitting higher layer entity submits them to the RLC sublayer.

- **Out-of-sequence delivery:** Alternatively to in-sequence delivery, it shall also be possible to allow that the receiving RLC entity delivers SDUs to higher layer in different order than submitted to RLC sublayer at the transmitting side.

It also provides for RLC connection establishment/release. As well as QoS setting and notification to higher layers in case of unrecoverable errors.

An example of the data flow for non-transparent (acknowledged/unacknowledged) data transfer is shown in Figure 26.

#### **5.3.1.4.3 PDCP Sublayer**

PDCP provides transmission and reception of Network PDUs in acknowledged, unacknowledged and transparent RLC mode.

It is responsible for the mapping of Network PDUs from one network protocol to one RLC entity and it provides compression in the transmitting entity and decompression in the receiving entity of redundant Network PDU control information (header compression/ decompression).

#### **5.3.1.4.4 BMC Sublayer**

The BMC provides a broadcast/multicast transmission service in the user plane on the radio interface for common user data in transparent or unacknowledged mode.

It can handle functionalities such as storage, scheduling and transmission of BMC messages.

#### **5.3.1.5 Layer 3 (Radio resource control sublayer)**

The Radio Resource Control (RRC) sublayer handles the control plane signalling of Layer 3 between the UEs and the radio access network. In addition to the relation with the upper layers (such as core network) the following main functions are performed:

- **Broadcast of information provided by the non-access stratum (Core Network).** The RRC layer performs system information broadcasting from the network to all UEs. The system information is normally repeated on a regular basis. This function supports broadcast of higher layer (above RRC) information. This information may be cell specific or not. As an example RRC may broadcast Core Network location service area information related to some specific cells.
- **Broadcast of information related to the access stratum.** The RRC layer performs system information broadcasting from the network to all UEs This function supports broadcast of typically cell-specific information.
- **Establishment, maintenance and release of an RRC connection between the UE and this radio interface.** The establishment of an RRC connection is initiated by a request from higher layers at the UE side to establish the first Signalling Connection for the UE. The establishment of an RRC connection includes an optional cell re-selection, an admission control, and a layer 2 signalling link establishment.
- **Establishment, reconfiguration and release of Radio Access Bearers.** The RRC layer will, on request from higher layers, perform the establishment, reconfiguration and release of radio access bearers in the user plane. A number of radio access bearers can be established to an UE at the same time. At establishment and reconfiguration, the RRC layer performs admission control and selects parameters describing the radio access bearer processing in layer 2 and layer 1, based on information from higher layers.
- **Assignment, reconfiguration and release of radio resources for the RRC connection.** The RRC layer handles the assignment of radio resources (e.g. codes and, for TDD only, timeslots)



needed for the RRC connection including needs from both the control and user plane. The RRC layer may reconfigure radio resources during an established RRC connection. This function includes co-ordination of the radio resource allocation between multiple radio bearers related to the same RRC connection. RRC controls the radio resources in the uplink and downlink such that UE and the radio access network can communicate using unbalanced radio resources (asymmetric uplink and downlink). RRC signals to the UE to indicate resource allocations for purposes of handover to GSM or other radio systems.

- **RRC connection mobility functions.** The RRC layer performs evaluation, decision and execution related to RRC connection mobility during an established RRC connection, such as handover, preparation of handover to GSM or other systems, cell re-selection and cell/paging area update procedures, based on e.g. measurements done by the UE.
- **Paging/notification.** The RRC layer can broadcast paging information from the network to selected UEs. The RRC layer can also initiate paging during an established RRC connection.
- **Control of requested QoS.** This function ensures that the QoS requested for the radio access bearers can be met. This includes the allocation of a sufficient number of radio resources.
- **UE measurement reporting and control of the reporting.** The measurements performed by the UE are controlled by the RRC layer, in terms of what to measure, when to measure and how to report, including both this radio interface and other systems. The RRC layer also performs the reporting of the measurements from the UE to the network.
- **Outer loop power control.**<sup>8</sup> The RRC layer controls setting of the target of the closed loop power control.
- **Control of ciphering.** The RRC layer provides procedures for setting of ciphering (on/off) between the UE and the radio access network.
- **Initial cell selection and re-selection in idle mode.** Selection of the most suitable cell based on idle mode measurements and cell selection criteria.
- **Arbitration of the radio resource allocation between the cells.** This function shall ensure optimal performance of the overall radio access network capacity.
- ~~□ **Broadcast of ODMA relay node neighbour information.** The RRC layer performs probe information broadcasting to allow ODMA routing information to be collected.~~
- ~~□ **Collating ODMA neighbour list and gradient information.** The ODMA relay node neighbour lists and their respective gradient information maintained by the RRC.~~
- ~~□ **Maintenance of number of ODMA relay node neighbours.** The RRC will adjust the broadcast powers used for probing messages to maintain the desired number of neighbours.~~
- ~~□ **Establishment, maintenance and release of a route between ODMA relay nodes.** The establishment of an ODMA route and RRC connection based upon the routing algorithm.~~
- ~~□ **Interworking between the Gateway ODMA relay node and the radio access network.** The RRC layer will control the interworking communication link between the Gateway ODMA relay node and the radio access network.~~
- **Contention resolution.** The RRC handles reallocations and releases of radio resources in case of collisions indicated by lower layers.
- **Slow DCA.** Allocation of preferred radio resources based on long-term decision criteria.
- **Timing advance control.**<sup>8</sup> The RRC controls the operation of timing advance.

---

<sup>8</sup> ~~TD-SCDMA~~ 1.28 Mcps TDD option does not support this function.

- **Active UE positioning**<sup>9</sup> This RRC layer will determine the position of each active UE according to the received information from physical layer.

---

<sup>9</sup> UTRA TDD high chip rate 3.84 Mcps TDD option does not support this function.

**5.3.1.6 Summary of major technical parameters\***

Parameter	"Value"	Reference to Section 5.3.2
Multiple access technique and duplexing scheme	Multiple Access: TDMA/CDMA Duplexing: TDD	5.3.2.1.1
Chip rate	3.84 Mcps 1.28 Mcps	5.3.2.1.4
Frame length and structure	<del>High chip rate</del> 3.84 Mcps TDD: Frame length: 10 ms 15 slots per frame, each 666.666 $\mu$ s <del>TD-SCDMA (Low chip rate)</del> 1.28 Mcps TDD: Sub-frame length: 5 ms 7 main slots per sub-frame, each 675 $\mu$ s	5.3.2.1.2
Occupied bandwidth	<del>High chip rate</del> 3.84 Mcps TDD: Less than 5 MHz <del>TD-SCDMA (Low chip rate)</del> 1.28 Mcps TDD: Less than 1.6 MHz	5.3.2.4.1 5.3.2.4.3
Adjacent Channel Leakage power ratio (transmitter side)	<del>High chip rate</del> :3.84 Mcps TDD: UE: (UE Power Class: +24, +21, +24 dBm) ACLR (5 MHz) = 33 dB ACLR (10 MHz) = 43 dB BS: ACLR (5 MHz) = 45 dB ACLR (10 MHz) = 55 dB <del>TD-SCDMA (Low chip rate)</del> 1.28 Mcps TDD: UE: (UE Power Class: + 21 dBm) ACLR (1.6 MHz) = 33 dB ACLR (3.2 MHz) = 43 dB BS: ACLR (1.6 MHz) = 40 dB ACLR (3.2 MHz) = 50 dB	5.3.2.4.1 5.3.2.4.3
Adjacent channel selectivity (receiver side)	<del>High chip rate</del> 3.84 Mcps TDD: UE: (UE power class +21, +24 dBm) ACS = 33 dB BS: ACS = 45 dB <del>TD-SCDMA (Low chip rate)</del> 1.28 Mcps TDD: UE: (UE power class +21 dBm) ACS= 33 dBm BS: ACS= 45 dBm	5.3.2.4.1 5.3.2.4.3
Random access mechanism	RACH burst on dedicated Uplink	5.3.2.1.2, 5.3.2.1.5

	slot(s)	
Channel estimation	Midambles are used for channel estimation	5.3.2.1.2
Inter base station asynchronous/synchronous operation	Synchronous operation	5.3.2.1.5 5.3.2.4.3

\* Note that the Work Item “Low chip rate TDD option” within 3GPP TSG RAN is ongoing; the outcome of this activity may imply modifications to some parameters of ~~TD-SCDMA~~ 1.28 Mcps TDD option.