

**TSG-RAN Meeting #9
Hawaii, U.S.A. , 20-22 September 2000**

RP-000347

Title: Agreed CRs to TS 25.224

Source: TSG-RAN WG1

Agenda item: 5.1.3

No.	R1 T-doc	Spec	CR	Rev	Subject	Cat	Current	New
1	R1-000993	25.224	019	1	Gain Factors for TDD Mode	F	3.3.0	3.4.0
2	R1-000940	25.224	025	-	Terminology regarding the beacon function	F	3.3.0	3.4.0
3	R1-000974	25.224	026	1	Synchronisation of timing advance adjustment and timing deviation measurement	F	3.3.0	3.4.0
4	R1-001118	25.224	027	1	CCTrCH UL/DL pairing for DL inner loop power control	F	3.3.0	3.4.0
5	R1-001005	25.224	028	1	RACH timing in TDD mode	F	3.3.0	3.4.0
6	R1-001000	25.224	030	1	TDD Access Bursts for HOV	F	3.3.0	3.4.0
7	R1-001031	25.224	032	-	Removal of ODMA related abbreviations and correction of references	F	3.3.0	3.4.0
8	R1-001097	25.224	033	-	Clarifications on the Out-of-sync handling for UTRA TDD	F	3.3.0	3.4.0

CHANGE REQUEST			Please see embedded help file at the bottom of this page for instructions on how to fill in this form correctly.		
25.224		CR 019r1		Current Version: 3.3.0	
GSM (AA.BB) or 3G (AA.BBB) specification number ↑		↑ CR number as allocated by MCC support team			
For submission to: RAN#9 <small>list expected approval meeting # here</small>	for approval for information	<input checked="" type="checkbox"/>	<input type="checkbox"/>	Strategic non-strategic	<input type="checkbox"/> <input type="checkbox"/>
				(for SMG use only)	

Form: CR cover sheet, version 2 for 3GPP and SMG The latest version of this form is available from: <ftp://ftp.3gpp.org/Information/CR-Form-v2.doc>

Proposed change affects: (U)SIM ME UTRAN / Radio Core Network
(at least one should be marked with an X)

Source: TSG RAN WG1 **Date:** 27/06/2000

Subject: Gain Factors for TDD Mode

Work item:

Category:	F Correction	<input checked="" type="checkbox"/>	Release:	Phase 2	<input type="checkbox"/>
	A Corresponds to a correction in an earlier release	<input type="checkbox"/>		Release 96	<input type="checkbox"/>
<small>(only one category shall be marked with an X)</small>	B Addition of feature	<input type="checkbox"/>		Release 97	<input type="checkbox"/>
	C Functional modification of feature	<input type="checkbox"/>		Release 98	<input type="checkbox"/>
	D Editorial modification	<input type="checkbox"/>		Release 99	<input checked="" type="checkbox"/>
				Release 00	<input type="checkbox"/>

Reason for change: Alignment with FDD Mode

Clauses affected: 4.2.2

Other specs affected:	Other 3G core specifications	<input checked="" type="checkbox"/>	→ List of CRs: TS25.223CR007r1
	Other GSM core specifications	<input type="checkbox"/>	→ List of CRs:
	MS test specifications	<input type="checkbox"/>	→ List of CRs:
	BSS test specifications	<input type="checkbox"/>	→ List of CRs:
	O&M specifications	<input type="checkbox"/>	→ List of CRs:

Other comments:



<----- double-click here for help and instructions on how to create a CR.

4.2 Transmitter Power Control

4.2.1 General Parameters

Power control is applied for the TDD mode to limit the interference level within the system thus reducing the intercell interference level and to reduce the power consumption in the UE.

All codes within one timeslot allocated to the same CCTrCH use the same transmission power, in case they have the same spreading factor.

Table 1: Transmit Power Control characteristics

	Uplink	Downlink
Power control rate	Variable 1-7 slots delay (2 slot SCH) 1-14 slots delay (1 slot SCH)	Variable, with rate depending on the slot allocation.
Step size		1, 2, 3 dB
Remarks	All figures are without processing and measurement times	Within one timeslot the powers of all active codes may be balanced to within a range of 20 dB

4.2.2 Uplink Control

4.2.2.1 General Limits

By means of higher layer signalling, the Maximum_Allowed_UL_TX_ power for uplink may be set to a value lower than what the terminal power class is capable of. The total transmit power shall not exceed the allowed maximum. If this would be the case, then the transmit power of all uplink physical channels in a timeslot is reduced by the same amount in dB.

4.2.2.2 PRACH

The transmit power for the PRACH is set by higher layers based on open loop power control as described in TS 25.331.

4.2.2.3 DPCH, PUSCH

4.2.2.3.1 Gain Factors

Two or more transport channels may be multiplexed onto a CCTrCH as described in [9]. These transport channels undergo rate matching which involves repetition or puncturing. This rate matching affects the transmit power required to obtain a particular E_b/N_0 . Thus, the transmission power of the CCTrCH shall be weighted by a gain factor β .

There are two ways of controlling the gain factors for different TFC's within a CCTrCH transmitted in a radio frame:

- β is signalled for the TFC, or
- β is computed for the TFC, based upon the signalled settings for a reference TFC.

Combinations of the two above methods may be used to associate β values to all TFC's in the TFCS for a CCTrCH. The two methods are described in sections 4.2.2.3.1.1 and 4.2.2.3.1.2 respectively. Several reference TFC's for several different CCTrCH's may be signalled from higher layers.

The weight and gain factors may vary on a radio frame basis depending upon the current SF and TFC used. The setting of weight and gain factors is independent of any other form of power control. That means that the transmit power P_{UL} is calculated according to the formula given below in section 4.2.2.3.2 and then the weight and gain factors are applied on top of that, cf. [10].

4.2.2.3.1.1 Signalled Gain Factors

When the gain factor β_j is signalled by higher layers for a certain TFC, the signalled values are used directly for weighting DPCH(s). Exact values are given in [10].

4.2.2.3.1.2 Computed Gain Factors

The gain factor β_j may also be computed for certain TFCs, based on the signalled settings for a reference TFC:

Let β_{ref} denote the signalled gain factor for the reference TFC. Further, let β_j denote the gain factor used for the j -th TFC.

Define the variable: $K_{ref} = \sum_i RM_i \cdot N_i$

where RM_i is the semi-static rate matching attribute for transport channel i , N_i is the number of bits output from the radio frame segmentation block for transport channel i and the sum is taken over all the transport channels i in the reference TFC.

Similarly, define the variable $K_j = \sum_i RM_i \cdot N_i$

where the sum is taken over all the transport channels i in the j -th TFC.

Moreover, define the variable $L_{ref} = \sum_i \frac{1}{SF_i}$

where SF_i is the spreading factor of DPCH i and the sum is taken over all DPCH i used in the reference TFC.

Similarly, define the variable $L_j = \sum_i \frac{1}{SF_i}$

where the sum is taken over all DPCH i used in the j -th TFC.

Then the variable A_j , called the nominal power relation for TFC j , is computed as:

$$A_j = \sqrt{\frac{L_j}{L_{ref}}} \times \sqrt{\frac{K_{ref}}{K_j}}$$

The gain factors β_j for the j -th TFC are then computed as follows:

- If $A_j > 1$, then β_j is the largest quantized β -value, for which the condition $\beta_j \leq 1 / A_j$ holds.
- If $A_j \leq 1$, then β_j is the smallest quantized β -value, for which the condition $\beta_j \geq 1 / A_j$ holds.

The quantized β -values are given in [10].

4.2.2.3.2 Power Control Loop

After the synchronisation between UTRAN and UE is established, the UE transits into open-loop transmitter power control (TPC).

The ~~transmitter~~ power ~~setting for each uplink DPCH in one CCTrCH of UE~~ shall be calculated by the following equation:

$$P_{UE} = \alpha P_{CCPCH} + (1-\alpha)L_0 + I_{BTS} + SIR_{TARGET} + \text{Constant value}$$

where

P_{UE} :	<u>Transmitter pPower setting level</u> in dBm, cf. section “Combination of physical channels in uplink” in [10]; This value corresponds to a particular CTrCH (due to CTrCH-specific SIR_{TARGET}) and a particular timeslot (due to possibly timeslot-specific α and I_{BTS}).
$L_{P-CCPCH}$:	Measure representing path loss in dB (reference transmit power is broadcast on BCH).
L_0 :	Long term average of path loss in dB.
I_{BTS} :	Interference signal power level at cell's receiver in dBm, which is broadcast on BCH.
α :	α is a weighting parameter which represents the quality of path loss measurements. α may be a function of the time delay between the uplink time slot and the most recent down link time slot containing a physical channel that provides the beacon function, see [8]. α is calculated at the UE. An example for calculating α as a function of the time delay is given in annex A.1.
SIR_{TARGET} :	Target SNR in dB. A higher layer outer loop adjusts the target SIR.
Constant value:	This value shall be set by higher Layer (operator matter), and is broadcast on BCH.

If the midamble is used in the evaluation of $L_{P-CCPCH}$ and L_0 , and the Tx diversity scheme used for the P-CCPCH involves the transmission of different midambles from the diversity antennas, the received power of the different midambles from the different antennas shall be combined prior to evaluation of these variables.

4.2.2.3.34 Out of synchronisation handling

UE shall shut off the uplink transmission if the following criteria is fulfilled:

- the UE estimates the received dedicated channel burst quality over the last [160] ms period to be worse than a threshold Q_{out} . This criterion is never fulfilled during the first [160] ms of the dedicated channel's existence. Q_{out} is defined implicitly by the relevant tests in TS 25.102;
- if the UE detect the beacon channel reception level [10 dBm] above the handover triggering level, then the UE uses [320] ms estimation period for the burst quality evaluation.

UE shall resume the uplink transmission if the following criteria is fulfilled:

- the UE estimates the burst reception quality over the last [160] ms period to be better than a threshold Q_{in} . This criterion is always fulfilled during the first [160] ms of the dedicated channel's existence. Q_{in} is defined implicitly by the relevant tests in TS 25.102.

<h2 style="margin: 0;">CHANGE REQUEST</h2>		Please see embedded help file at the bottom of this page for instructions on how to fill in this form correctly.
25.224	CR	025
GSM (AA.BB) or 3G (AA.BBB) specification number ↑		↑ CR number as allocated by MCC support team
For submission to: RAN#9		Current Version: 3.3.0
list expected approval meeting # here ↑		
for approval	<input checked="" type="checkbox"/>	strategic
for information	<input type="checkbox"/>	non-strategic
		(for SMG use only)

Form: CR cover sheet, version 2 for 3GPP and SMG The latest version of this form is available from: <ftp://ftp.3gpp.org/Information/CR-Form-v2.doc>

Proposed change affects: (U)SIM ME UTRAN / Radio Core Network
(at least one should be marked with an X)

Source: TSG RAN WG1 **Date:** 00-07-04

Subject: Terminology regarding the beacon function

Work item: _____

Category:	F Correction	<input checked="" type="checkbox"/>	Release:	Phase 2	<input type="checkbox"/>
(only one category shall be marked with an X)	A Corresponds to a correction in an earlier release	<input type="checkbox"/>		Release 96	<input type="checkbox"/>
	B Addition of feature	<input type="checkbox"/>		Release 97	<input type="checkbox"/>
	C Functional modification of feature	<input type="checkbox"/>		Release 98	<input type="checkbox"/>
	D Editorial modification	<input type="checkbox"/>		Release 99	<input checked="" type="checkbox"/>
				Release 00	<input type="checkbox"/>

Reason for change: Currently, there are different terms in connection with the beacon function that may lead to some misunderstanding:

- Physical Channels providing the Beacon Function'
- Physical Channels with Beacon Function'
- Beacon Channels'

This CR tries to make the terminology more consistent in such a sense that

- Physical Channels have Beacon Characteristics
- Physical Channels with Beacon Characteristics are called Beacon Channels
- The ensemble of Beacon Channels provide the Beacon Function

Clauses affected: 4.2.2.3; 4.4; Annex C

Other specs affected:	Other 3G core specifications	<input checked="" type="checkbox"/>	→ List of CRs:	CR221-028, CR225-015
	Other GSM core specifications	<input type="checkbox"/>	→ List of CRs:	
	MS test specifications	<input type="checkbox"/>	→ List of CRs:	
	BSS test specifications	<input type="checkbox"/>	→ List of CRs:	
	O&M specifications	<input type="checkbox"/>	→ List of CRs:	

Other comments: This CR supersedes CR224-024.



<----- double-click here for help and instructions on how to create a CR.

4.2.2.3 DPCH, PUSCH

After the synchronisation between UTRAN and UE is established, the UE transits into open-loop transmitter power control (TPC).

The transmitter power of UE shall be calculated by the following equation:

$$P_{UE} = \alpha L_{P-CCPCH} + (1-\alpha)L_0 + I_{BTS} + SIR_{TARGET} + \text{Constant value}$$

where

P_{UE} : Transmitter power level in dBm.

$L_{P-CCPCH}$: Measure representing path loss in dB (reference transmit power is broadcast on BCH).

L_0 : Long term average of path loss in dB.

I_{BTS} : Interference signal power level at cell's receiver in dBm, which is broadcast on BCH.

α : α is a weighting parameter which represents the quality of path loss measurements. α may be a function of the time delay between the uplink time slot and the most recent down link time slot containing a ~~beacon~~ ~~physical channel that provides the beacon function~~, see [8]. α is calculated at the UE. An example for calculating α as a function of the time delay is given in annex A.1.

SIR_{TARGET} : Target SNR in dB. A higher layer outer loop adjusts the target SIR.

Constant value: This value shall be set by higher Layer (operator matter). and is broadcast on BCH.

If the midamble is used in the evaluation of $L_{P-CCPCH}$ and L_0 , and the Tx diversity scheme used for the P-CCPCH involves the transmission of different midambles from the diversity antennas, the received power of the different midambles from the different antennas shall be combined prior to evaluation of these variables.

4.4 Synchronisation and Cell Search Procedures

4.4.1 Cell Search

During the ~~initial~~ cell search, the UE searches for a cell. ~~It then and~~ determines the ~~midamble, the~~ downlink scrambling code, ~~basic midamble code~~ and frame synchronisation of that cell. ~~The initial cell search uses the Synchronisation Channel (SCH) described in [8]. The generation of synchronisation codes is described in [10]. How cell search is typically done is described in Annex C.~~

~~This initial cell search is carried out in three steps:~~

~~Step 1: Slot synchronisation~~

~~During the first step of the initial cell search procedure the UE uses the primary synchronisation code c_p to acquire slot synchronisation to the strongest cell. Furthermore, frame synchronisation with the uncertainty of 1 out of 2 is obtained in this step. A single matched filter (or any similar device) is used for this purpose, that is matched to the primary synchronisation code which is common to all cells.~~

~~Step 2: Frame synchronisation and code group identification~~

~~During the second step of the initial cell search procedure, the UE uses the modulated Secondary Synchronisation Codes to find frame synchronisation and identify one out of 32 code groups. Each code group is linked to a specific t_{Offset} , thus to a specific frame timing, and is containing 4 specific scrambling codes. Each scrambling code is associated with a specific short and long basic midamble code.~~

~~In Case 2 it is required to detect the position of the next synchronization slots. To detect the position of the next synchronization slots, the primary synchronization code is correlated with the received signal at offsets of 7 and 8 time slots from the position of the primary code that was detected in Step 1.~~

~~Then, the received signal at the positions of the synchronization codes is correlated with the primary synchronization Code C_p and the secondary synchronization codes $\{C_0, \dots, C_{15}\}$. Note that the correlations can be performed coherently over M time slots, where at each slot a phase correction is provided by the correlation with the primary code. The minimal number of time slots is $M=1$, and the performance improves with increasing M .~~

~~Step 3: Scrambling code identification~~

~~During the third and last step of the initial cell search procedure, the UE determines the exact basic midamble code and the accompanying scrambling code used by the found cell. They are identified through correlation over the P-CCPCH with all four midambles of the code group identified in the second step. Thus the third step is a one out of four decision. This step is taking into account that the P-CCPCH containing the BCH is transmitted using the first channelization code ($c_{Q=16}^{(h=1)}$ in [10]) and using the first midamble $m^{(1)}$ (derived from basic midamble code m_p in [8]). Thus P-CCPCH code and midamble can be immediately derived when knowing scrambling code and basic midamble code.~~

~~NOTE:—The cell parameters change from frame to frame, cf. "Table 7 Alignment of cell parameter cycling and SFN" in [10].~~

Annex C (informative): Cell search procedure

During the cell search, the UE searches for a cell and determines the downlink scrambling code, basic midamble code and frame synchronisation of that cell. The cell search is typically carried out in three steps:

Step 1: Primary synchronisation code acquisition

During the first step of the cell search procedure, the UE uses the SCH's primary synchronisation code to find a cell. This is typically done with a single matched filter (or any similar device) matched to the primary synchronisation code which is common to all cells. A cell can be found by detecting peaks in the matched filter output.

Note that for a cell of SCH slot configuration case 1, the SCH can be received periodically every 15 slots. In case of a cell of SCH slot configuration case 2, the following SCH slot can be received at offsets of either 7 or 8 slots from the previous SCH slot.

Step 2: Code group identification and slot synchronisation

During the second step of the cell search procedure, the UE uses the SCH's secondary synchronisation codes to identify 1 out of 32 code groups for the cell found in the first step. This is typically done by correlating the received signal with the secondary synchronisation codes at the detected peak positions of the first step. The primary synchronisation code provides the phase reference for coherent detection of the secondary synchronisation codes. The code group can then uniquely be identified by detection of the maximum correlation values.

Each code group indicates a different t_{offset} parameter and 4 specific cell parameters. Each of the cell parameters is associated with one particular downlink scrambling code and one particular long and short basic midamble code. When the UE has determined the code group, it can unambiguously derive the slot timing of the found cell from the detected peak position in the first step and the t_{offset} parameter of the found code group in the second step.

Note that the modulation of the secondary synchronisation codes also indicates the position of the SCH slot within a 2 frames period, e.g. a frame with even or odd SFN. Additionally, in the case of SCH slot configuration following case 2, the SCH slot position within one frame, e.g. first or last SCH slot, can be derived from the modulation of the secondary synchronisation codes.

Step 3: Downlink scrambling code, basic midamble code identification and frame synchronisation

During the third and last step of the cell search procedure, the UE determines the exact downlink scrambling code, basic midamble code and frame timing used by the found cell. The long basic midamble code can be identified by correlation over the P-CCPCH (or any other beacon channel) with the 4 possible long basic midamble codes of the code group found in the second step. A P-CCPCH (or any other beacon channel) always uses the midamble $m^{(1)}$ (and in case of Block-STTD also midamble $m^{(2)}$) derived from the long basic midamble code and always uses a fixed and pre-assigned channelisation code.

When the long basic midamble code has been identified, downlink scrambling code and cell parameter are also known. The UE can read system and cell specific BCH information and acquire frame synchronisation.

Note that even for an initial cell parameter assignment, a cell cycles through a set composed of 2 different cell parameters according to the SFN of a frame, e.g. the downlink scrambling code and the basic midamble code of a cell alternate for frames with even and odd SFN. Cell parameter cycling leaves the code group of a cell unchanged.

If the UE has received information about which cell parameters or SCH configurations to search for, cell search can be simplified.

Annex ~~E~~D (informative): Change history

Change history							
Date	TSG #	TSG Doc.	CR	Rev	Subject/Comment	Old	New
14/01/00	RAN_05	RP-99594	-	-	Approved at TSG RAN #5 and placed under Change Control	-	3.0.0
14/01/00	RAN_06	RP-99698	001	01	Primary and Secondary CCPCH in TDD	3.0.0	3.1.0
14/01/00	RAN_06	RP-99698	002	-	Measurement procedure of received reference power for OL-TPC in TDD	3.0.0	3.1.0
14/01/00	RAN_06	RP-99699	004	1	STTD capability for P-CCPCH, TDD component	3.0.0	3.1.0
14/01/00	RAN_06	RP-99697	005	1	Alignment of Terminology Regarding Spreading for TDD Mode	3.0.0	3.1.0
14/01/00	-	-	-	-	Change history was added by the editor	3.1.0	3.1.1
31/03/00	RAN_07	RP-000070	003	2	Cycling of cell parameters	3.1.1	3.2.0
31/03/00	RAN_07	RP-000070	007	2	Clarifications on the UL synchronisation and Timing advance	3.1.1	3.2.0
31/03/00	RAN_07	RP-000070	008	-	Modification of SIR threshold on setting TPC	3.1.1	3.2.0
31/03/00	RAN_07	RP-000070	009	1	New section describing the random access procedure	3.1.1	3.2.0
31/03/00	RAN_07	RP-000070	011	-	Removal of Synchronisation Case 3 in TDD	3.1.1	3.2.0
31/03/00	RAN_07	RP-000070	012	1	Clarifications on power control procedures	3.1.1	3.2.0
31/03/00	RAN_07	RP-000070	013	-	Signal Point Constellation	3.1.1	3.2.0
31/03/00	RAN_07	RP-000070	014	2	Out-of-sync handling for UTRA TDD	3.1.1	3.2.0
31/03/00	RAN_07	RP-000070	015	-	Removal of ODMA from the TDD specifications	3.1.1	3.2.0
26/06/00	RAN_08	RP-000274	016	-	Editorial correction for the power control section in 25.224	3.2.0	3.3.0
26/06/00	RAN_08	RP-000274	017	-	Power control for TDD during DTX	3.2.0	3.3.0
26/06/00	RAN_08	RP-000274	018	1	Power Control for PDSCH	3.2.0	3.3.0
26/06/00	RAN_08	RP-000274	020	1	Editorial modification of 25.224	3.2.0	3.3.0
26/06/00	RAN_08	RP-000274	021	-	Clarifications on TxDiversity for UTRA TDD	3.2.0	3.3.0
26/06/00	RAN_08	RP-000274	022	1	Introduction of the TDD DSCH detection procedure in TS 25.224	3.2.0	3.3.0
26/06/00	RAN_08	RP-000274	023	-	Downlink power control on timeslot basis	3.2.0	3.3.0

<h2 style="margin: 0;">CHANGE REQUEST</h2>			<i>Please see embedded help file at the bottom of this page for instructions on how to fill in this form correctly.</i>
TS 25.224	CR 026r1	Current Version: 3.3.0	
<i>GSM (AA.BB) or 3G (AA.BBB) specification number ↑</i>		<i>↑ CR number as allocated by MCC support team</i>	
For submission to: RAN#9	For approval <input checked="" type="checkbox"/>	Strategic <input type="checkbox"/>	<i>(for SMG use only)</i>
<i>list expected approval meeting # here ↑</i>	For information <input type="checkbox"/>	Non-strategic <input type="checkbox"/>	

Form: CR cover sheet, version 2 for 3GPP and SMG The latest version of this form is available from: <ftp://ftp.3gpp.org/Information/CR-Form-v2.doc>

Proposed change affects: (U)SIM ME UTRAN / Radio Core Network
(at least one should be marked with an X)

Source: TSG RAN WG1 **Date:** 06/07/00

Subject: Synchronisation of Timing Advance adjustment and Timing Deviation measurement

Work item: _____

Category:	F Correction <input checked="" type="checkbox"/>	Release:	Phase 2 <input type="checkbox"/>
<i>(only one category shall be marked With an X)</i>	A Corresponds to a correction in an earlier release <input type="checkbox"/>		Release 96 <input type="checkbox"/>
	B Addition of feature <input type="checkbox"/>		Release 97 <input type="checkbox"/>
	C Functional modification of feature <input type="checkbox"/>		Release 98 <input type="checkbox"/>
	D Editorial modification <input type="checkbox"/>		Release 99 <input checked="" type="checkbox"/>
			Release 00 <input type="checkbox"/>

Reason for change: The UL delay estimation at NodeB is used to determine UE location. This measurement must be correlated with the UE's current timing advance to calculate the actual UL propagation delay. It is also beneficial to know the exact frame TA will take effect so that TA failures can be quickly recovered and layer three signalling overhead can be reduced.

Clauses affected: 4.3

Other specs Affected:	Other 3G core specifications <input type="checkbox"/>	→ List of CRs:	
	Other GSM core specifications <input type="checkbox"/>	→ List of CRs:	
	MS test specifications <input type="checkbox"/>	→ List of CRs:	
	BSS test specifications <input type="checkbox"/>	→ List of CRs:	
	O&M specifications <input type="checkbox"/>	→ List of CRs:	

Other comments: _____

4.3 Timing Advance

UTRAN may adjust the UE transmission timing with timing advance. The initial value for timing advance will be determined in the UTRAN by measurement of the timing of the PRACH. The required timing advance will be represented as an 6 bit number (0-63) being the multiple of 4 chips which is nearest to the required timing advance.

When Timing Advance is used the UTRAN will continuously measure the timing of a transmission from the UE and send the necessary timing advance value. On receipt of this value the UE shall adjust the timing of its transmissions accordingly in steps of ± 4 chips. The transmission of TA values is done by means of higher layer messages. Upon receiving the TA command the UE shall adjust its transmission timing according to the timing advance command at the frame number specified by higher layer signaling, beginning of the next frame that fulfils the SFN Mod20 = 0 criteria and which does not occur sooner than 10 frames after the TTI period for the DCCH carrying the timing advance command ended. The UE is signaled the TA value in advance of the specified frame activation time to allow for local processing of the command and application of the TA adjustment on the specified frame. Node-B is also signaled the TA value and radio frame number that the TA adjustment is expected to take place.

When TDD to TDD handover takes place the UE shall transmit in the new cell with timing advance TA adjusted by the relative timing difference Δt between the new and the old cell:

$$TA_{\text{new}} = TA_{\text{old}} + 2\Delta t$$

CHANGE REQUEST		Please see embedded help file at the bottom of this page for instructions on how to fill in this form correctly.
TS 25.224	CR 027r1	Current Version: 3.3.0
GSM (AA.BB) or 3G (AA.BBB) specification number ↑	↑ CR number as allocated by MCC support team	
For submission to: RAN#9 <small>list expected approval meeting # here ↑</small>	For approval <input checked="" type="checkbox"/> For information <input type="checkbox"/>	Strategic <input type="checkbox"/> Non-strategic <input type="checkbox"/> <small>(for SMG Use only)</small>

Form: CR cover sheet, version 2 for 3GPP and SMG The latest version of this form is available from: ftp://ftp.3gpp.org/Information/CR-Form-v2.doc

Proposed change affects: (U)SIM ME UTRAN / Radio Core Network
(at least one should be marked with an X)

Source: TSG RAN WG1 **Date:** 24/08/00

Subject: CCTrCH UL/DL pairing for DL Inner Loop Power Control

Work item: 25.224

Category:	F Correction <input checked="" type="checkbox"/> A Corresponds to a correction in an earlier release <input type="checkbox"/> B Addition of feature <input type="checkbox"/> C Functional modification of feature <input type="checkbox"/> D Editorial modification <input type="checkbox"/>	Release:	Phase 2 <input type="checkbox"/> Release 96 <input type="checkbox"/> Release 97 <input type="checkbox"/> Release 98 <input type="checkbox"/> Release 99 <input checked="" type="checkbox"/> Release 00 <input type="checkbox"/>
------------------	--	-----------------	--

(only one category Shall be marked With an X)

Reason for change: The present specification does allow for independent DL CCTrCH power control, it is necessary to define the association ("pairing") between TPC command streams on uplink DPCH and USCH CCTrCH's, with downlink DPCH and DSCH CCTrCH's. It is also necessary to more specifically state the rules for cases where there are multiple TPC commands applicable to the same CCTrCH due to either asymmetry or downlink pauses.

Clauses affected: 4.2.3.3

Other specs Affected:	Other 3G core specifications <input type="checkbox"/> Other GSM core specifications <input type="checkbox"/> MS test specifications <input type="checkbox"/> BSS test specifications <input type="checkbox"/> O&M specifications <input type="checkbox"/>	→ List of CRs: → List of CRs: → List of CRs: → List of CRs: → List of CRs:	
------------------------------	---	--	--

Other comments:

4.2.3.3 Dedicated Physical Channel, PDSCH

The initial transmission power of the downlink Dedicated Physical Channel and the PDSCH is set by the network. After the initial transmission, the UTRAN transits into SIR-based inner loop power control.

The UE shall generate TPC commands to control the network transmit power and send them in the TPC field of the uplink DPCH and PUSCH. An example on how to derive the TPC commands is given in Annex A.2

~~As a response to the received TPC command, UTRAN may adjust the transmit power of all downlink DPCHs and PDSCHs of this radio link~~

~~The association between TPC commands sent on uplink DPCH and PUSCH, with the power controlled downlink DPCH and PDSCH is signaled by higher layers.-~~

~~In the case that no associated downlink data is scheduled within 15 timeslots before the transmission of a TPC command then this is regarded as a transmission pause. The TPC commands in this case shall be derived from measurements on the P-CCPCH. An example solution for the generation of the TPC command is given in Annex A 2.~~

~~Each TPC command shall always be based on all associated downlink transmissions received since the previous related TPC command. Related TPC commands are defined as TPC commands associated with the same downlink CCTrCHs. If there are no associated downlink transmissions between two or more uplink transmissions carrying related TPC commands, then these TPC commands shall be identical and they shall be regarded by the UTRAN as a single TPC command. This rule applies both to the case where the measurements are based on a CCTrCH or, in the case of a pause, on the P-CCPCH.~~

~~As a response to the received TPC command, UTRAN may adjust the transmit power.~~ When the TPC command is judged as "down", the transmission power may be reduced by one step, whereas if judged as "up", the transmission power may be raised by one step. The UTRAN may apply an individual offset to the transmission power in each timeslot according to the downlink interference level at the UE. The transmission power of one DPCH or PDSCH shall not exceed the limits set by higher layer signalling by means of Maximum_DL_Power (dB) and Minimum_DL_Power (dB). The transmission power is defined as the average power of the complex QPSK symbols of a single DPCH before spreading.

During a downlink transmission pause, the UTRAN may accumulate the TPC commands received. The initial UTRAN transmission power for the first data transmission after the pause may then be set to the sum of transmission power before the pause and a power offset according to the accumulated TPC commands. Additionally this sum may include a constant set by the operator and a correction term due to uncertainties in the reception of the TPC bits.

The total downlink transmission power at the nodeB within one timeslot shall not exceed Maximum Transmission Power set by higher layer signalling. In case the total power of the sum of all transmissions would exceed this limit, then the transmission power of all downlink DPCHs is reduced by the amount that allows fulfilling the requirement. The same amount of power reduction is applied to all DPCHs.

A higher layer outer loop adjusts the target SIR.

CHANGE REQUEST		<i>Please see embedded help file at the bottom of this page for instructions on how to fill in this form correctly.</i>	
25.224 CR 028r1		Current Version: 3.3.0	
<small>GSM (AA.BB) or 3G (AA.BBB) specification number ↑</small>		<small>↑ CR number as allocated by MCC support team</small>	
For submission to: RAN#9 <small>list expected approval meeting # here ↑</small>	for approval for information	<input checked="" type="checkbox"/>	Strategic non-strategic <input type="checkbox"/> (for SMG use only)

Form: CR cover sheet, version 2 for 3GPP and SMG The latest version of this form is available from: ftp://ftp.3gpp.org/Information/CR-Form-v2.doc

Proposed change affects: (U)SIM ME UTRAN / Radio Core Network
(at least one should be marked with an X)

Source: TSG RAN WG1 **Date:** 22/08/2000

Subject: RACH timing in TDD mode

Work item:

Category:
(only one category shall be marked with an X)

F Correction	<input checked="" type="checkbox"/>	Release: Phase 2	<input type="checkbox"/>
A Corresponds to a correction in an earlier release	<input type="checkbox"/>	Release 96	<input type="checkbox"/>
B Addition of feature	<input type="checkbox"/>	Release 97	<input type="checkbox"/>
C Functional modification of feature	<input type="checkbox"/>	Release 98	<input type="checkbox"/>
D Editorial modification	<input type="checkbox"/>	Release 99	<input checked="" type="checkbox"/>
		Release 00	<input type="checkbox"/>

Reason for change: Clarification on RACH timing

Clauses affected: 4.7

Other specs affected:

Other 3G core specifications	<input type="checkbox"/>	→ List of CRs:	
Other GSM core specifications	<input type="checkbox"/>	→ List of CRs:	
MS test specifications	<input type="checkbox"/>	→ List of CRs:	
BSS test specifications	<input type="checkbox"/>	→ List of CRs:	
O&M specifications	<input type="checkbox"/>	→ List of CRs:	

Other comments:



<----- double-click here for help and instructions on how to create a CR.

4.7 Random access procedure

The physical random access procedure described below is invoked whenever a higher layer requests transmission of a message on the RACH. The physical random access procedure is controlled by primitives from RRC and MAC. Retransmission on the RACH in case of failed transmission (e.g. due to a collision) is controlled by higher layers. Thus, the backoff algorithm and associated handling of timers is not described here. The definition of the RACH in terms of PRACH sub-channels and associated Access Service Classes is broadcasted on the BCH in each cell. Parameters for common physical channel uplink outer loop power control are also broadcasted on the BCH in each cell. The UE needs to decode this information prior to transmission on the RACH.

4.7.1 Physical random access procedure

The physical random access procedure described in this subclause is initiated upon request of a PHY-Data-REQ primitive from the MAC sublayer (cf. TS 25.321 and TS 25.303).

Before the physical random-access procedure can be initiated, Layer 1 shall receive the following information by a CPHY-TrCH-Config-REQ from the RRC layer:

- the available PRACH sub-channels for each Access Service Class (ASC);
- the timeslot, spreading factor, channelisation code, midamble, repetition period and offset for each PRACH sub-channel. (There is a 1:1 mapping between spreading code and midamble as defined by RRC);
- the set of Transport Format parameters;
- the set of parameters for common physical channel uplink outer loop power control.

NOTE: The above parameters may be updated from higher layers before each physical random access procedure is initiated. At each initiation of the physical random access procedure, Layer 1 shall receive the following information from the higher layers (MAC):

- the Transport Format to be used for the PRACH message;
- the ASC of the PRACH transmission;
- the data to be transmitted (Transport Block Set).

The physical random-access procedure shall be performed as follows.

- 1 Randomly select the PRACH sub-channel from the available ones for the given ASC. The random function shall be such that each of the allowed selections is chosen with equal probability.
- 2 Derive the available access slots in the next N frames, defined by SFN, SFN+1, ..., SFN+N-1 for the selected PRACH sub-channel with the help of SFN (where N is the repetition period of the selected PRACH sub-channel). Randomly select an uplink access slot from the available access slots in the next frame, defined by SFN, if there is one available. If there is no access slot available in the next frame, defined by SFN then, randomly select one access slot from the available access slots in the following frame, defined by SFN+1. This search is performed for all frames in increasing order, defined by SFN, SFN+1, ..., SFN+N-1, until an available access slot is found. The random function shall be such that each of the allowed selections is chosen with equal probability.
- 3 Randomly select a spreading code from the available ones for the given ASC. The random function shall be such that each of the allowed selections is chosen with equal probability. The midamble is derived from the selected spreading code.
- 4 Set the PRACH message transmission power level according to the specification for common physical channels in uplink (see subclause 4.2.2.2).
- 5 Transmit the random access message with no timing advance.

CHANGE REQUEST		Please see embedded help file at the bottom of this page for instructions on how to fill in this form correctly.
25.224	CR	030r1
GSM (AA.BB) or 3G (AA.BBB) specification number ↑		↑ CR number as allocated by MCC support team
For submission to: RAN#9	for approval <input checked="" type="checkbox"/>	Current Version: 3.3.0
list expected approval meeting # here ↑	for information <input type="checkbox"/>	strategic <input type="checkbox"/> (for SMG use only)
		non-strategic <input type="checkbox"/>

Form: CR cover sheet, version 2 for 3GPP and SMG The latest version of this form is available from: ftp://ftp.3gpp.org/Information/CR-Form-v2.doc

Proposed change affects: (U)SIM ME UTRAN / Radio Core Network
 (at least one should be marked with an X)

Source: TSG RAN WG1 **Date:** 2000-08-23

Subject: TDD Access Bursts for HOV

Work item:

Category:	F Correction <input checked="" type="checkbox"/> A Corresponds to a correction in an earlier release <input type="checkbox"/> B Addition of feature <input type="checkbox"/> C Functional modification of feature <input type="checkbox"/> D Editorial modification <input type="checkbox"/>	Release:	Phase 2 <input type="checkbox"/> Release 96 <input type="checkbox"/> Release 97 <input type="checkbox"/> Release 98 <input type="checkbox"/> Release 99 <input checked="" type="checkbox"/> Release 00 <input type="checkbox"/>
------------------	--	-----------------	--

(only one category shall be marked with an X)

Reason for change: This CR enables the usage of access bursts (burst type 3) for HOV purposes in case oh non-synchronised cells.

Clauses affected: 5.3

Other specs affected:	Other 3G core specifications <input type="checkbox"/> Other GSM core specifications <input type="checkbox"/> MS test specifications <input type="checkbox"/> BSS test specifications <input type="checkbox"/> O&M specifications <input type="checkbox"/>	→ List of CRs: → List of CRs: → List of CRs: → List of CRs: → List of CRs:
------------------------------	---	--

Other comments:



<----- double-click here for help and instructions on how to create a CR.

4.3 Timing Advance

UTRAN may adjust the UE transmission timing with timing advance. The initial value for timing advance will be determined in the UTRAN by measurement of the timing of the PRACH. The required timing advance will be represented as an 6 bit number (0-63) being the multiple of 4 chips which is nearest to the required timing advance.

When Timing Advance is used the UTRAN will continuously measure the timing of a transmission from the UE and send the necessary timing advance value. On receipt of this value the UE shall adjust the timing of its transmissions accordingly in steps of ± 4 chips. The transmission of TA values is done by means of higher layer messages. Upon receiving the TA command the UE shall adjust its transmission timing according to the timing advance command at the beginning of the next frame that fulfils the SFN Mod 20 = 0 criteria and which does not occur sooner than 10 frames after the TTI period for the DCCH carrying the timing advance command ended.

If TA is enabled by higher layers, after handover ~~When TDD to TDD handover takes place~~ the UE shall transmit in the new cell with timing advance TA_{new} adjusted by the relative timing difference Δt between the new and the old cell:

$$TA_{\text{new}} = TA_{\text{old}} + 2\Delta t$$

CHANGE REQUEST		Please see embedded help file at the bottom of this page for instructions on how to fill in this form correctly.	
25.224 CR 032		Current Version: 3.3.0	
GSM (AA.BB) or 3G (AA.BBB) specification number ↑		↑ CR number as allocated by MCC support team	
For submission to: RAN#9	for approval <input checked="" type="checkbox"/>	strategic <input type="checkbox"/>	(for SMG use only)
list expected approval meeting # here ↑	for information <input type="checkbox"/>	non-strategic <input type="checkbox"/>	

Form: CR cover sheet, version 2 for 3GPP and SMG The latest version of this form is available from: <ftp://ftp.3gpp.org/Information/CR-Form-v2.doc>

Proposed change affects: (U)SIM ME UTRAN / Radio Core Network
(at least one should be marked with an X)

Source: TSG RAN WG1 **Date:** 15-Aug-2000

Subject: Removal of ODMA related abbreviations and correction of references

Work item: _____

Category:	F Correction <input checked="" type="checkbox"/>	Release:	Phase 2 <input type="checkbox"/>
	A Corresponds to a correction in an earlier release <input type="checkbox"/>		Release 96 <input type="checkbox"/>
<i>(only one category shall be marked with an X)</i>	B Addition of feature <input type="checkbox"/>		Release 97 <input type="checkbox"/>
	C Functional modification of feature <input type="checkbox"/>		Release 98 <input type="checkbox"/>
	D Editorial modification <input type="checkbox"/>		Release 99 <input checked="" type="checkbox"/>
			Release 00 <input type="checkbox"/>

Reason for change: ODMA is not part of release 99. References should use reference table. Reference to 25.104 is an FDD reference, not TDD. DPCH abbreviation used for consistency.

Clauses affected: 2, 3, 4.2.2.2, 4.2.2.3.1, 4.2.3.3, 4.4.1, 4.4.2.1.2, 4.4.2.2.1, 4.4.2.2.2, 4.7.1

Other specs affected:	Other 3G core specifications <input type="checkbox"/>	→ List of CRs:	
	Other GSM core specifications <input type="checkbox"/>	→ List of CRs:	
	MS test specifications <input type="checkbox"/>	→ List of CRs:	
	BSS test specifications <input type="checkbox"/>	→ List of CRs:	
	O&M specifications <input type="checkbox"/>	→ List of CRs:	

Other comments: _____

<----- double-click here for help and instructions on how to create a CR.

2 References

The following documents contain provisions which, through reference in this text, constitute provisions of the present document.

- References are either specific (identified by date of publication, edition number, version number, etc.) or non-specific.
- For a specific reference, subsequent revisions do not apply.
- For a non-specific reference, the latest version applies.

- [1] 3G TS 25.201: "Physical layer - general description".
- [2] 3G TS 25.102: "UE physical layer capabilities".
- [3] 3G TS 25.211: "Physical channels and mapping of transport channels onto physical channels (FDD)".
- [4] 3G TS 25.212: "Multiplexing and channel coding (FDD)".
- [5] 3G TS 25.213: "Spreading and modulation (FDD)".
- [6] 3G TS 25.214: "Physical layer procedures (FDD)".
- [7] 3G TS 25.215: "Physical Layer - Measurements (FDD)".
- [8] 3G TS 25.221: "Physical channels and mapping of transport channels onto physical channels (TDD)".
- [9] 3G TS 25.222: "Multiplexing and channel coding (TDD)".
- [10] 3G TS 25.223: "Spreading and modulation (TDD)".
- [11] 3G TS 25.225: "Physical Layer - Measurements (TDD)".
- [12] 3G TS 25.301: "Radio Interface Protocol Architecture".
- [13] 3G TS 25.302: "Services Provided by the Physical Layer".
- [14] 3G TS 25.401: "UTRAN Overall Description".
- [15] 3G TS 25.331: "RRC Protocol Specification"
- [16] [3G TS 25.433: " UTRAN Iub Interface NBAP Signalling"](#)
- [17] [3G TS 25.105: " UTRA \(BS\) TDD; Radio transmission and Reception"](#)
- [18] [3G TS 25.321: " MAC protocol specification"](#)
- [19] [3G TS 25.303: " Interlayer Procedures in Connected Mode"](#)

3 Abbreviations

For the purposes of the present document, the following abbreviations apply:

BCCH	Broadcast Control Channel
BCH	Broadcast Channel
CCTrCH	Coded Composite Transport Channel
DCA	Dynamic Channel Allocation
DPCH	Dedicated Physical Channel

DTX	Discontinuous Transmission
FACH	Forward Access Channel
NRT	Non-Real Time
ODMA	Opportunity Division Multiple Access
ORACH	ODMA Random Access Channel
P-CCPCH	Primary Common Control Physical Channel
PRACH	Physical Random Access Channel
RACH	Random Access Channel
RT	Real Time
RU	Resource Unit
S-CCPCH	Secondary Common Control Physical Channel
SCH	Synchronisation Channel
SFN	System Frame Number
SSCH	Secondary Synchronisation Channel
STD	Selective Transmit Diversity
TA	Timing Advance
TPC	Transmit Power Control
TSTD	Time Switched Transmit Diversity
TxAA	Transmit Adaptive Antennas
UE	User Equipment
VBR	Variable Bit Rate

4 Physical layer procedures (TDD)

4.1 General

4.2 Transmitter Power Control

4.2.1 General Parameters

Power control is applied for the TDD mode to limit the interference level within the system thus reducing the intercell interference level and to reduce the power consumption in the UE.

All codes within one timeslot allocated to the same CCTrCH use the same transmission power, in case they have the same spreading factor.

Table 1: Transmit Power Control characteristics

	Uplink	Downlink
Power control rate	Variable 1-7 slots delay (2 slot SCH) 1-14 slots delay (1 slot SCH)	Variable, with rate depending on the slot allocation.
Step size		1, 2, 3 dB
Remarks	All figures are without processing and measurement times	Within one timeslot the powers of all active codes may be balanced to within a range of 20 dB

4.2.2 Uplink Control

4.2.2.1 General Limits

By means of higher layer signalling, the Maximum_Allowed_UL_TX_ power for uplink may be set to a value lower than what the terminal power class is capable of. The total transmit power shall not exceed the allowed maximum. If this would be the case, then the transmit power of all uplink physical channels in a timeslot is reduced by the same amount in dB.

4.2.2.2 PRACH

The transmit power for the PRACH is set by higher layers based on open loop power control as described in [\[15\]TS 25.331](#).

4.2.2.3 DPCH, PUSCH

After the synchronisation between UTRAN and UE is established, the UE transits into open-loop transmitter power control (TPC).

The transmitter power of UE shall be calculated by the following equation:

$$P_{UE} = \alpha L_{P-CCPCH} + (1-\alpha)L_0 + I_{BTS} + SIR_{TARGET} + \text{Constant value}$$

where

P_{UE} : Transmitter power level in dBm.

$L_{P-CCPCH}$: Measure representing path loss in dB (reference transmit power is broadcast on BCH).

L_0 : Long term average of path loss in dB.

I_{BTS} : Interference signal power level at cell's receiver in dBm, which is broadcast on BCH.

α : α is a weighting parameter which represents the quality of path loss measurements. α may be a function of the time delay between the uplink time slot and the most recent down link time slot containing a physical channel that provides the beacon function, see [8]. α is calculated at the UE. An example for calculating α as a function of the time delay is given in annex A.1.

SIR_{TARGET} : Target SNR in dB. A higher layer outer loop adjusts the target SIR.

Constant value: This value shall be set by higher Layer (operator matter). and is broadcast on BCH.

If the midamble is used in the evaluation of $L_{P-CCPCH}$ and L_0 , and the Tx diversity scheme used for the P-CCPCH involves the transmission of different midambles from the diversity antennas, the received power of the different midambles from the different antennas shall be combined prior to evaluation of these variables.

4.2.2.3.1 Out of synchronisation handling

UE shall shut off the uplink transmission if the following criteria is fulfilled:

- the UE estimates the received dedicated channel burst quality over the last [160] ms period to be worse than a threshold Q_{out} . This criterion is never fulfilled during the first [160] ms of the dedicated channel's existence. Q_{out} is defined implicitly by the relevant tests in [\[2\]TS 25.102](#);
- if the UE detect the beacon channel reception level [10 dBm] above the handover triggering level, then the UE uses [320] ms estimation period for the burst quality evaluation.

UE shall resume the uplink transmission if the following criteria is fulfilled:

- the UE estimates the burst reception quality over the last [160] ms period to be better than a threshold Q_{in} . This criterion is always fulfilled during the first [160] ms of the dedicated channel's existence. Q_{in} is defined implicitly by the relevant tests in [\[2\]TS 25.102](#).

4.2.3 Downlink Control

4.2.3.1 P-CCPCH, PICH

The Primary CCPCH transmit power is set by higher layer signalling and can be changed based on network determination on a slow basis. The reference transmit power of the P-CCPCH is signalled on the BCH. The PICH is transmitted with the same power as the P-CCPCH.

4.2.3.2 S-CCPCH

The relative transmit power of the Secondary CCPCH compared to the P-CCPCH transmit power is set by higher layer signalling.

4.2.3.3 ~~DPCH~~edicated Physical Channel, PDSCH

The initial transmission power of the downlink ~~DPCH~~edicated Physical Channel and the PDSCH is set by the network. After the initial transmission, the UTRAN transits into SIR-based inner loop power control.

The UE shall generate TPC commands to control the network transmit power and send them in the TPC field of the uplink DPCH and PUSCH. An example on how to derive the TPC commands is given in Annex A.2

As a response to the received TPC command, UTRAN may adjust the transmit power of all downlink DPCHs and PDSCHs of this radio link. When the TPC command is judged as "down", the transmission power may be reduced by one step, whereas if judged as "up", the transmission power may be raised by one step. The UTRAN may apply an individual offset to the transmission power in each timeslot according to the downlink interference level at the UE. The transmission power of one DPCH or PDSCH shall not exceed the limits set by higher layer signalling by means of Maximum_DL_Power (dB) and Minimum_DL_Power (dB). The transmission power is defined as the average power of the complex QPSK symbols of a single DPCH before spreading.

During a downlink transmission pause, the UTRAN may accumulate the TPC commands received. The initial UTRAN transmission power for the first data transmission after the pause may then be set to the sum of transmission power before the pause and a power offset according to the accumulated TPC commands. Additionally this sum may include a constant set by the operator and a correction term due to uncertainties in the reception of the TPC bits.

The total downlink transmission power at the nodeB within one timeslot shall not exceed Maximum Transmission Power set by higher layer signalling. In case the total power of the sum of all transmissions would exceed this limit, then the transmission power of all downlink DPCHs is reduced by the amount that allows fulfilling the requirement. The same amount of power reduction is applied to all DPCHs.

A higher layer outer loop adjusts the target SIR.

4.2.3.3.1 Out of synchronisation handling

When the dedicated physical channel out of sync criteria based on the received burst quality is as given in the subclause 4.4.2 then the UE shall set the uplink TPC command = "up". The CRC based criteria shall not be taken into account in TPC bit value setting.

4.3 Timing Advance

UTRAN may adjust the UE transmission timing with timing advance. The initial value for timing advance will be determined in the UTRAN by measurement of the timing of the PRACH. The required timing advance will be represented as an 6 bit number (0-63) being the multiple of 4 chips which is nearest to the required timing advance.

When Timing Advance is used the UTRAN will continuously measure the timing of a transmission from the UE and send the necessary timing advance value. On receipt of this value the UE shall adjust the timing of its transmissions accordingly in steps of ± 4 chips. The transmission of TA values is done by means of higher layer messages. Upon receiving the TA command the UE shall adjust its transmission timing according to the timing advance command at the beginning of the next frame that fulfils the SFN Mod 20 = 0 criteria and which does not occur sooner than 10 frames after the TTI period for the DCCH carrying the timing advance command ended.

When TDD to TDD handover takes place the UE shall transmit in the new cell with timing advance TA adjusted by the relative timing difference Δt between the new and the old cell:

$$TA_{\text{new}} = TA_{\text{old}} + 2\Delta t$$

4.3.1 Timing advance with UL Synchronization

If UL Synchronization is used, the timing advance is sub-chip granular and with high accuracy in order to enable synchronous CDMA in the UL. The required timing advance will be represented as a multiple of 1/4 chips.

The UTRAN will continuously measure the timing of a transmission from the UE and send the necessary timing advance value. On receipt of this value the UE will adjust the timing of its transmissions accordingly in steps of $\pm 1/4$ chips.

Support of UL synchronisation is optional for the UE.

4.4 Synchronisation and Cell Search Procedures

4.4.1 Cell Search

During the initial cell search, the UE searches for a cell. It then determines the midamble, the downlink scrambling code and frame synchronisation of that cell. The initial cell search uses the Synchronisation Channel (SCH) described in [8]. The generation of synchronisation codes is described in [10].

This initial cell search is carried out in three steps:

Step 1: Slot synchronisation

During the first step of the initial cell search procedure the UE uses the primary synchronisation code c_p to acquire slot synchronisation to the strongest cell. Furthermore, frame synchronisation with the uncertainty of 1 out of 2 is obtained in this step. A single matched filter (or any similar device) is used for this purpose, that is matched to the primary synchronisation code which is common to all cells.

Step 2: Frame synchronisation and code-group identification

During the second step of the initial cell search procedure, the UE uses the modulated Secondary Synchronisation Codes to find frame synchronisation and identify one out of 32 code groups. Each code group is linked to a specific t_{Offset} , thus to a specific frame timing, and is containing 4 specific scrambling codes. Each scrambling code is associated with a specific short and long basic midamble code.

In Case 2 it is required to detect the position of the next synchronization slots. To detect the position of the next synchronization slots, the primary synchronization code is correlated with the received signal at offsets of 7 and 8 time slots from the position of the primary code that was detected in Step 1.

Then, the received signal at the positions of the synchronization codes is correlated with the primary synchronization Code C_p and the secondary synchronization codes $\{C_0, \dots, C_{15}\}$. Note that the correlations can be performed coherently over M time slots, where at each slot a phase correction is provided by the correlation with the primary code. The minimal number of time slots is $M=1$, and the performance improves with increasing M .

Step 3: Scrambling code identification

During the third and last step of the initial cell-search procedure, the UE determines the exact basic midamble code and the accompanying scrambling code used by the found cell. They are identified through correlation over the P-CCPCH with all four midambles of the code group identified in the second step. Thus the third step is a one out of four decision. This step is taking into account that the P-CCPCH containing the BCH is transmitted using the first channelization code ($c_{Q=16}^{(h=1)}$ in [10]) and using the first midamble $m^{(1)}$ (derived from basic midamble code m_p in [8]).

Thus P-CCPCH code and midamble can be immediately derived when knowing scrambling code and basic midamble code.

NOTE: The cell parameters change from frame to frame, ~~seeef~~ "Table 7 Alignment of cell parameter cycling and SFN" in [10].

4.4.2 Dedicated channel synchronisation

4.4.2.1 Synchronisation primitives

4.4.2.1.1 General

For the dedicated channels, synchronisation primitives are used to indicate the synchronisation status of radio links, both in uplink and downlink. The definition of the primitives is given in the following subclauses.

4.4.2.1.2 Downlink synchronisation primitives

Layer 1 in the UE shall every radio frame check synchronisation status of the downlink dedicated channels. Synchronisation status is indicated to higher layers, using the CPHY-Sync-IND or CPHY-Out-of-Sync-IND primitives.

Out-of-sync shall be reported using the CPHY-Out-of-Sync-IND primitive if **any** of the following criteria **are** fulfilled:

- the UE estimates the received dedicated channel burst quality over the last [160] ms period to be worse than a threshold Q_{out} . This criterion is never fulfilled during the first [160] ms of the dedicated channel's existence. Q_{out} is defined implicitly by the relevant tests in [\[2\]TS-25.102](#);
- if the UE detect the beacon channel reception level [10 dBm] above the handover triggering level, the UE uses [320] ms estimation period for the burst quality evaluation;
- the last [16] transport blocks, as observed on all TrCHs using CRC, are received with incorrect CRC. In addition, over the last [160] ms, no transport block has been received with correct CRC. In case the beacon channel reception criteria is fulfilled the values are [32] transport blocks and [320] ms respectively.

In-sync shall be reported using the CPHY-Sync-IND primitive if both of the following criteria are fulfilled:

- the UE estimates the burst reception quality over the last [160] ms period to be better than a threshold Q_{in} . This criterion is always fulfilled during the first [160] ms of the dedicated channel's existence. Q_{in} is defined implicitly by the relevant tests in [\[17\]TS-25.104](#);
- at least one transport block, as observed on all TrCHs using CRC, is received with correct CRC. If there is no TrCH using CRC, this criterion is always fulfilled.

How the primitives are used by higher layers is described in [\[15\]TS-25.331](#).

4.4.2.1.3 Uplink synchronisation primitives

Layer 1 in the Node B shall every radio frame check synchronisation status of the radio link. Synchronisation status is indicated to the RL Failure/Restored triggering function using either the CPHY-Sync-IND or CPHY-Out-of-Sync-IND primitive.

The exact criteria for indicating in-sync/out-of-sync is not subject to specification, but could e.g. be based on received burst quality or CRC checks. One example would be to have the same criteria as for the downlink synchronisation status primitives.

4.4.2.2 Radio link monitoring

4.4.2.2.1 Downlink radio link failure

The downlink radio links are monitored by the UE, to trigger radio link failure procedures. The downlink radio link failure criteria is specified in [\[15\]TS-25.331](#), and is based on the synchronisation status primitives CPHY-Sync-IND and CPHY-Out-of-Sync-IND, indicating in-sync and out-of-sync respectively.

4.4.2.2.2 Uplink radio link failure/restore

The uplink radio links are monitored by the Node B, to trigger radio link failure/restore procedures. Once the radio links have been established, they will be in the in-sync or out-of-sync states as shown in figure 1 in subclause 4.3.2.1. Transitions between those two states are described below.

The uplink radio link failure/restore criteria is based on the synchronisation status primitives CPHY-Sync-IND and CPHY-Out-of-Sync-IND, indicating in-sync and out-of-sync respectively.

When the radio links are in the in-sync state, Node B shall start timer $T_{RLFAILURE}$ after receiving $N_{OUTSYNC_IND}$ consecutive out-of-sync indications. Node B shall stop and reset timer $T_{RLFAILURE}$ upon receiving successive N_{INSYNC_IND} in-sync indications. If $T_{RLFAILURE}$ expires, Node B shall trigger the RL Failure procedure and indicate which radio links are out-of-sync. When the RL Failure procedure is triggered, the radio links' state changes to the out-of-sync state.

When the radio links are in the out-of-sync state, after receiving $N_{\text{INSYNC_IND}}$ successive in-sync indications Node B shall trigger the RL Restore procedure and indicate which radio links have re-established synchronisation. When the RL Restore procedure is triggered, the radio links' state changes to the in-sync state.

The specific parameter settings (values of $T_{\text{RLFAILURE}}$, $N_{\text{OUTSYNC_IND}}$, and $N_{\text{INSYNC_IND}}$) are configurable, see [\[16\]TS-25.433](#).

4.5 Discontinuous transmission (DTX) of Radio Frames

Discontinuous transmission (DTX) is applied in up- and downlink when the total bit rate after transport channel multiplexing differs from the total channel bit rate of the allocated dedicated physical channels.

Rate matching is used in order to fill resource units completely, that are only partially filled with data. In the case that after rate matching and multiplexing no data at all is to be transmitted in a resource unit the complete resource unit is discarded from transmission. This applies also to the case where only one resource unit is allocated and no data has to be transmitted.

When DTX is applied in the uplink and after a period of $(N_{\text{OUTSYNC_IND}} / 2) - 1$ silent frames no data has to be transmitted, then a dummy burst should be generated and transmitted in the next possible frame.

This dummy burst should have the same slot format as the normal burst where DTX is used. The dummy burst is filled with an arbitrary bit pattern, contains a TFCI and TPC bits if inner loop PC is applied. The TFCI of the dummy burst should indicate that there is no data to be transmitted.

4.6 Downlink Transmit Diversity

Downlink transmit diversity for DPCH, P-CCPCH, and SCH is optional in UTRAN. Its support is mandatory at the UE.

4.6.1 Transmit Diversity for DPCH

The transmitter structure to support transmit diversity for DPCH transmission is shown in figure 1. Channel coding, interleaving and spreading are done as in non-diversity mode. The spread complex valued signal is fed to both TX antenna branches, and weighted with antenna specific weight factors w_1 and w_2 . The weight factors are complex valued signals (i.e., $w_i = a_i + jb_i$), in general. These weight factors are calculated on a per slot and per user basis.

The weight factors are determined by the UTRAN. Examples of transmit diversity schemes are given in annex B.

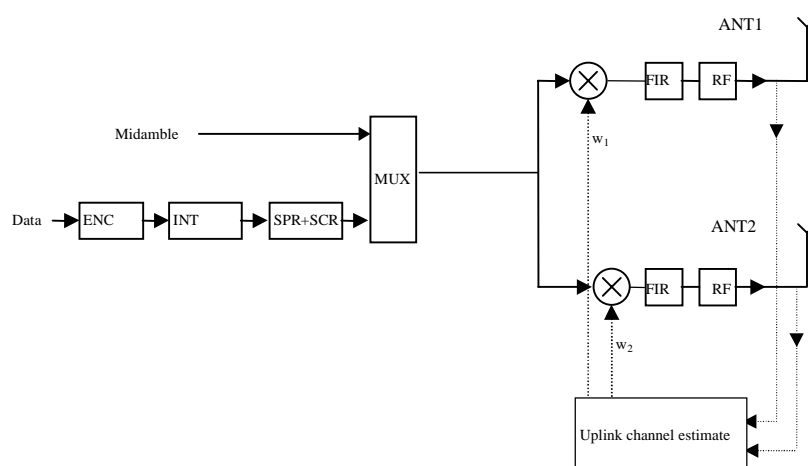

Figure 1: Downlink transmitter structure to support Transmit Diversity for DPCH transmission (UTRAN Access Point)

4.6.2 Transmit Diversity for SCH

Time Switched Transmit Diversity (TSTD) can be employed as transmit diversity scheme for the synchronisation channel.

4.6.2.1 SCH Transmission Scheme

The transmitter structure to support transmit diversity for SCH transmission is shown in figure 2. P-SCH and S-SCH are transmitted from antenna 1 and antenna 2 alternatively. An example for the antenna switching pattern is shown in figure 3.

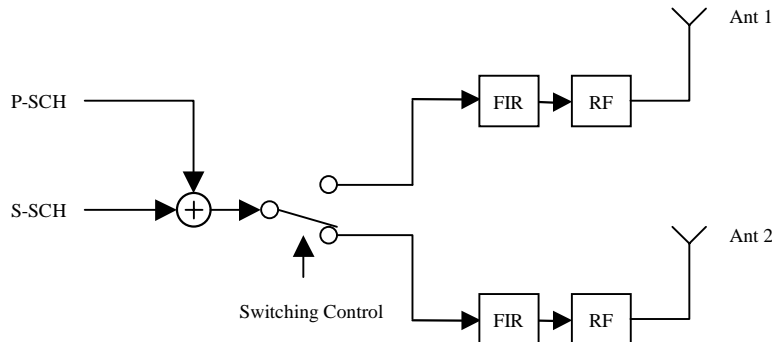

Figure 2: Downlink transmitter structure to support Transmit Diversity for SCH transmission (UTRAN Access Point)

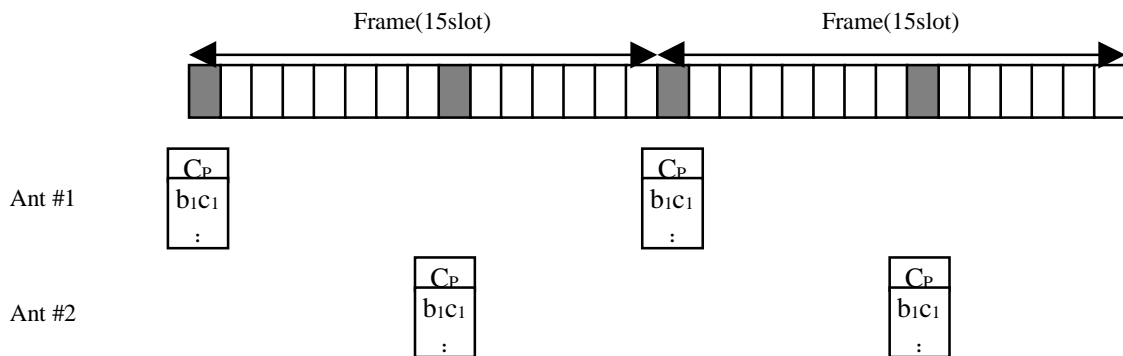

Figure 3: Antenna Switching Pattern (Case 2)

4.6.3 Transmit Diversity for P-CCPCH

Block Space Time Transmit Diversity (Block STTD) may be employed as transmit diversity scheme for the Primary Common Control Physical Channels (P-CCPCH).

4.6.3.1 P-CCPCH Transmission Scheme

The open loop downlink transmit diversity employs a Block Space Time Transmit Diversity scheme (Block STTD).

A block diagram of the Block STTD transmitter is shown in figure 4. Before Block STTD encoding, channel coding, rate matching, interleaving and bit-to-symbol mapping are performed as in the non-diversity mode.

Block STTD encoding is separately performed for each of the two data fields present in a burst (each data field contains N data symbols). For each data field at the encoder input, 2 data fields are generated at its output, corresponding to each of the diversity antennas. The Block STTD encoding operation is illustrated in figure 5, where the superscript * stands for complex conjugate. If N is an odd number, the first symbol of the block shall not be STTD encoded and the same symbol will be transmitted with equal power from both antennas.

After Block STTD encoding both branches are separately spread and scrambled as in the non-diversity mode.

The use of Block STTD encoding will be indicated by higher layers.

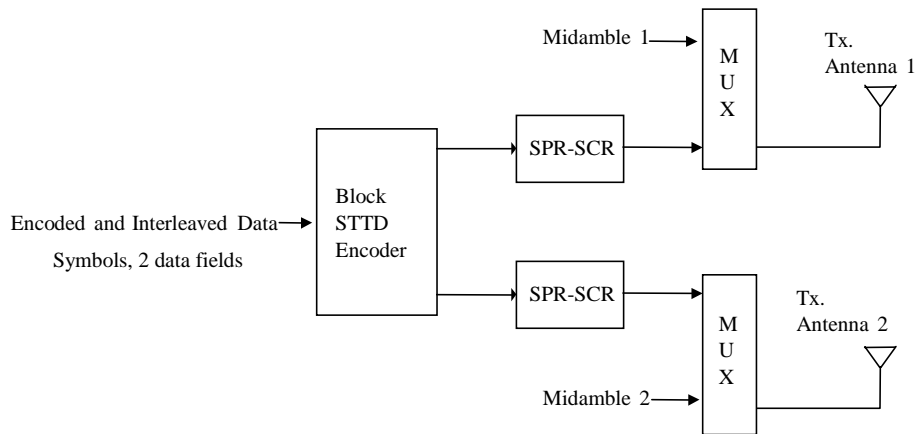

Figure 4: Block Diagram of the transmitter (STTD)

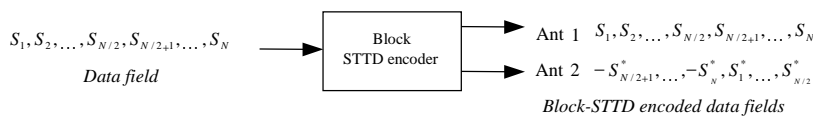

Figure 5: Block Diagram of Block STTD encoder. The symbols S_i are QPSK. N is the length of the block to be encoded

4.7 Random access procedure

The physical random access procedure described below is invoked whenever a higher layer requests transmission of a message on the RACH. The physical random access procedure is controlled by primitives from RRC and MAC. Retransmission on the RACH in case of failed transmission (e.g. due to a collision) is controlled by higher layers. Thus, the backoff algorithm and associated handling of timers is not described here. The definition of the RACH in terms of PRACH sub-channels and associated Access Service Classes is broadcasted on the BCH in each cell. Parameters for common physical channel uplink outer loop power control are also broadcasted on the BCH in each cell. The UE needs to decode this information prior to transmission on the RACH.

4.7.1 Physical random access procedure

The physical random access procedure described in this subclause is initiated upon request of a PHY-Data-REQ primitive from the MAC sublayer ([seeef. \[18\]TS-25.321](#) and [\[19\]TS-25.303](#)).

3GPP TSG RAN Meeting #9
Hawaii, USA, 20-22 September 2000

Document R1-00-1097
 e.g. for 3GPP use the format TP-99xxx
 or for SMG, use the format P-99-xxx

CHANGE REQUEST		Please see embedded help file at the bottom of this page for instructions on how to fill in this form correctly.
25.224	CR 033	Current Version: V3.3.0
GSM (AA.BB) or 3G (AA.BBB) specification number ↑	↑ CR number as allocated by MCC support team	
For submission to: TSG RAN #9 <small>list expected approval meeting # here</small>	For approval for information <input checked="" type="checkbox"/>	strategic <input type="checkbox"/> non-strategic <input type="checkbox"/> <small>(for SMG use only)</small>

Form: CR cover sheet, version 2 for 3GPP and SMG The latest version of this form : <http://ftp.3gpp.org/Information/CR-Form-v2.doc>

Proposed change affects: (U)SIM ME UTRAN / Radio Core Network
(at least one should be marked with an X)

Source: TSG RAN WG1 **Date:** 22.08.2000

Subject: Clarifications on the Out-of-sync handling for UTRA TDD

Work item: TS25.224

Category:	F Correction <input checked="" type="checkbox"/> A Corresponds to a correction in an earlier release <input type="checkbox"/> B Addition of feature <input type="checkbox"/> C Functional modification of feature <input type="checkbox"/> D Editorial modification <input type="checkbox"/>	Release:	Phase 2 <input type="checkbox"/> Release 96 <input type="checkbox"/> Release 97 <input type="checkbox"/> Release 98 <input type="checkbox"/> Release 99 <input checked="" type="checkbox"/> Release 00 <input type="checkbox"/>
------------------	--	-----------------	--

(only one category shall be marked with an X)

Reason for change: Some clarifications/corrections required for the out-of-sync scheme

Clauses affected: 4.2.2.3.1, 4.4.2.1.2, 4.4.2.2.2, 4.5

Other specs affected:	Other 3G core specifications <input type="checkbox"/> → List of CRs: Other GSM core specifications <input type="checkbox"/> → List of CRs: MS test specifications <input type="checkbox"/> → List of CRs: BSS test specifications <input type="checkbox"/> → List of CRs: O&M specifications <input type="checkbox"/> → List of CRs:	
------------------------------	--	--

Other comments:



help.doc

<----- double-click here for help and instructions on how to create a CR.

4.2.2 Uplink Control

4.2.2.1 General Limits

By means of higher layer signalling, the Maximum_Allowed_UL_TX_ power for uplink may be set to a value lower than what the terminal power class is capable of. The total transmit power shall not exceed the allowed maximum. If this would be the case, then the transmit power of all uplink physical channels in a timeslot is reduced by the same amount in dB.

4.2.2.2 PRACH

The transmit power for the PRACH is set by higher layers based on open loop power control as described in TS 25.331.

4.2.2.3 DPCH, PUSCH

After the synchronisation between UTRAN and UE is established, the UE transits into open-loop transmitter power control (TPC).

The transmitter power of UE shall be calculated by the following equation:

$$P_{UE} = \alpha L_{P-CCPCH} + (1-\alpha)L_0 + I_{BTS} + SIR_{TARGET} + \text{Constant value}$$

where

P_{UE} : Transmitter power level in dBm.

$L_{P-CCPCH}$: Measure representing path loss in dB (reference transmit power is broadcast on BCH).

L_0 : Long term average of path loss in dB.

I_{BTS} : Interference signal power level at cell's receiver in dBm, which is broadcast on BCH.

α : α is a weighting parameter which represents the quality of path loss measurements. α may be a function of the time delay between the uplink time slot and the most recent down link time slot containing a physical channel that provides the beacon function, see [8]. α is calculated at the UE. An example for calculating α as a function of the time delay is given in annex A.1.

SIR_{TARGET} : Target SNR in dB. A higher layer outer loop adjusts the target SIR.

Constant value: This value shall be set by higher Layer (operator matter). and is broadcast on BCH.

If the midamble is used in the evaluation of $L_{P-CCPCH}$ and L_0 , and the Tx diversity scheme used for the P-CCPCH involves the transmission of different midambles from the diversity antennas, the received power of the different midambles from the different antennas shall be combined prior to evaluation of these variables.

4.2.2.3.1 Out of synchronisation handling

UE shall shut off the uplink transmission if the following criteria is fulfilled:

- The UE estimates the received dedicated channel burst quality over the last [160] ms period to be worse than a threshold Q_{out} . This criterion is never fulfilled during the first [160] ms of the dedicated channel's existence. Q_{out} is defined implicitly by the relevant tests in TS 25.102;

UE shall resume the uplink transmission if the following criteria is fulfilled:

- The UE estimates the burst reception quality over the last [160] ms period to be better than a threshold Q_{in} . This criterion is always fulfilled during the first [160] ms of the dedicated channel's existence. Q_{in} is defined implicitly by the relevant tests in TS 25.102.
- If the UE detects the beacon channel reception level [10 dB] above the handover triggering level, then the UE shall be allowed to use a further [320] ms estimation period for the burst quality evaluation.

4.2.3 Downlink Control

4.2.3.1 P-CCPCH, PICH

The Primary CCPCH transmit power is set by higher layer signalling and can be changed based on network determination on a slow basis. The reference transmit power of the P-CCPCH is signalled on the BCH. The PICH is transmitted with the same power as the P-CCPCH.

4.2.3.2 S-CCPCH

The relative transmit power of the Secondary CCPCH compared to the P-CCPCH transmit power is set by higher layer signalling.

4.2.3.3 Dedicated Physical Channel, PDSCH

The initial transmission power of the downlink Dedicated Physical Channel and the PDSCH is set by the network. After the initial transmission, the UTRAN transits into SIR-based inner loop power control.

The UE shall generate TPC commands to control the network transmit power and send them in the TPC field of the uplink DPCH and PUSCH. An example on how to derive the TPC commands is given in Annex A.2

As a response to the received TPC command, UTRAN may adjust the transmit power of all downlink DPCHs and PDSCHs of this radio link. When the TPC command is judged as "down", the transmission power may be reduced by one step, whereas if judged as "up", the transmission power may be raised by one step. The UTRAN may apply an individual offset to the transmission power in each timeslot according to the downlink interference level at the UE. The transmission power of one DPCH or PDSCH shall not exceed the limits set by higher layer signalling by means of Maximum_DL_Power (dB) and Minimum_DL_Power (dB). The transmission power is defined as the average power of the complex QPSK symbols of a single DPCH before spreading.

During a downlink transmission pause, the UTRAN may accumulate the TPC commands received. The initial UTRAN transmission power for the first data transmission after the pause may then be set to the sum of transmission power before the pause and a power offset according to the accumulated TPC commands. Additionally this sum may include a constant set by the operator and a correction term due to uncertainties in the reception of the TPC bits.

The total downlink transmission power at the nodeB within one timeslot shall not exceed Maximum Transmission Power set by higher layer signalling. In case the total power of the sum of all transmissions would exceed this limit, then the transmission power of all downlink DPCHs is reduced by the amount that allows fulfilling the requirement. The same amount of power reduction is applied to all DPCHs.

A higher layer outer loop adjusts the target SIR.

4.2.3.3.1 Out of synchronisation handling

When the dedicated physical channel out of sync criteria based on the received burst quality is as given in the subclause 4.4.2 then the UE shall set the uplink TPC command = "up". The CRC based criteria shall not be taken into account in TPC bit value setting.

4.3 Timing Advance

UTRAN may adjust the UE transmission timing with timing advance. The initial value for timing advance will be determined in the UTRAN by measurement of the timing of the PRACH. The required timing advance will be represented as an 6 bit number (0-63) being the multiple of 4 chips which is nearest to the required timing advance.

When Timing Advance is used the UTRAN will continuously measure the timing of a transmission from the UE and send the necessary timing advance value. On receipt of this value the UE shall adjust the timing of its transmissions accordingly in steps of ± 4 chips. The transmission of TA values is done by means of higher layer messages. Upon receiving the TA command the UE shall adjust its transmission timing according to the timing advance command at the beginning of the next frame that fulfils the SFN Mod 20 = 0 criteria and which does not occur sooner than 10 frames after the TTI period for the DCCH carrying the timing advance command ended.

When TDD to TDD handover takes place the UE shall transmit in the new cell with timing advance TA adjusted by the relative timing difference Δt between the new and the old cell:

$$TA_{\text{new}} = TA_{\text{old}} + 2\Delta t$$

4.3.1 Timing advance with UL Synchronization

If UL Synchronization is used, the timing advance is sub-chip granular and with high accuracy in order to enable synchronous CDMA in the UL. The required timing advance will be represented as a multiple of $1/4$ chips.

The UTRAN will continuously measure the timing of a transmission from the UE and send the necessary timing advance value. On receipt of this value the UE will adjust the timing of its transmissions accordingly in steps of $\pm 1/4$ chips.

Support of UL synchronisation is optional for the UE.

4.4 Synchronisation and Cell Search Procedures

4.4.1 Cell Search

During the initial cell search, the UE searches for a cell. It then determines the midamble, the downlink scrambling code and frame synchronisation of that cell. The initial cell search uses the Synchronisation Channel (SCH) described in [8]. The generation of synchronisation codes is described in [10].

This initial cell search is carried out in three steps:

Step 1: Slot synchronisation

During the first step of the initial cell search procedure the UE uses the primary synchronisation code c_p to acquire slot synchronisation to the strongest cell. Furthermore, frame synchronisation with the uncertainty of 1 out of 2 is obtained in this step. A single matched filter (or any similar device) is used for this purpose, that is matched to the primary synchronisation code which is common to all cells.

Step 2: Frame synchronisation and code-group identification

During the second step of the initial cell search procedure, the UE uses the modulated Secondary Synchronisation Codes to find frame synchronisation and identify one out of 32 code groups. Each code group is linked to a specific t_{Offset} , thus to a specific frame timing, and is containing 4 specific scrambling codes. Each scrambling code is associated with a specific short and long basic midamble code.

In Case 2 it is required to detect the position of the next synchronization slots. To detect the position of the next synchronization slots, the primary synchronization code is correlated with the received signal at offsets of 7 and 8 time slots from the position of the primary code that was detected in Step 1.

Then, the received signal at the positions of the synchronization codes is correlated with the primary synchronization Code C_p and the secondary synchronization codes $\{C_0, \dots, C_{15}\}$. Note that the correlations can be performed coherently over M time slots, where at each slot a phase correction is provided by the correlation with the primary code. The minimal number of time slots is $M=1$, and the performance improves with increasing M .

Step 3: Scrambling code identification

During the third and last step of the initial cell-search procedure, the UE determines the exact basic midamble code and the accompanying scrambling code used by the found cell. They are identified through correlation over the P-CCPCH with all four midambles of the code group identified in the second step. Thus the third step is a one out of four decision. This step is taking into account that the P-CCPCH containing the BCH is transmitted using the first channelization code ($c_{Q=16}^{(h=1)}$ in [10]) and using the first midamble $\mathbf{m}^{(1)}$ (derived from basic midamble code \mathbf{m}_p in [8]).

Thus P-CCPCH code and midamble can be immediately derived when knowing scrambling code and basic midamble code.

NOTE: The cell parameters change from frame to frame, cf. "Table 7 Alignment of cell parameter cycling and SFN" in [10].

4.4.2 Dedicated channel synchronisation

4.4.2.1 Synchronisation primitives

4.4.2.1.1 General

For the dedicated channels, synchronisation primitives are used to indicate the synchronisation status of radio links, both in uplink and downlink. The definition of the primitives is given in the following subclauses.

4.4.2.1.2 Downlink synchronisation primitives

Layer 1 in the UE shall every radio frame check synchronisation status of the downlink dedicated channels. Synchronisation status is indicated to higher layers, using the CPHY-Sync-IND or CPHY-Out-of-Sync-IND primitives.

Out-of-sync shall be reported using the CPHY-Out-of-Sync-IND primitive if either of the following criteria is fulfilled:

- the UE estimates the received dedicated channel burst quality over the last [160] ms period to be worse than a threshold Q_{out} . This criterion is never fulfilled during the first [160] ms of the dedicated channel's existence. Q_{out} is defined implicitly by the relevant tests in TS 25.102;
- if the UE detect the beacon channel reception level [10 dB~~m~~] above the handover triggering level, the UE uses [320] ms estimation period for the burst quality evaluation;
- the last [16] transport blocks, as observed on all TrCHs using CRC, are received with incorrect CRC ~~and in-~~ addition, over the last [160] ms, no transport block has been received with correct CRC. In case the beacon channel reception criteria is fulfilled the values are [32] transport blocks and [320] ms respectively.

In-sync shall be reported using the CPHY-Sync-IND primitive if both of the following criteria are fulfilled:

- the UE estimates the burst reception quality over the last [160] ms period to be better than a threshold Q_{in} . This criterion is always fulfilled during the first [160] ms of the dedicated channel's existence. Q_{in} is defined implicitly by the relevant tests in TS 25.104;
- at least one transport block, as observed on all TrCHs using CRC, is received with correct CRC. If there is no TrCH using CRC, this criterion is always fulfilled.

In-sync shall be reported using the CPHY-Sync-IND primitive in case of DTX if the following criterion is fulfilled:

- The UE receives a special burst in case of DTX and estimates its burst reception quality to be better than a threshold Q_{in} .

How the primitives are used by higher layers is described in TS 25.331.

4.4.2.1.3 Uplink synchronisation primitives

Layer 1 in the Node B shall every radio frame check synchronisation status of the radio link. Synchronisation status is indicated to the RL Failure/Restored triggering function using either the CPHY-Sync-IND or CPHY-Out-of-Sync-IND primitive.

The exact criteria for indicating in-sync/out-of-sync is not subject to specification, but could e.g. be based on received burst quality or CRC checks. One example would be to have the same criteria as for the downlink synchronisation status primitives.

4.4.2.2 Radio link monitoring

4.4.2.2.1 Downlink radio link failure

The downlink radio links are monitored by the UE, to trigger radio link failure procedures. The downlink radio link failure criteria is specified in TS 25.331, and is based on the synchronisation status primitives CPHY-Sync-IND and CPHY-Out-of-Sync-IND, indicating in-sync and out-of-sync respectively.

4.4.2.2.2 Uplink radio link failure/restore

The uplink radio links are monitored by the Node B, to trigger radio link failure/restore procedures. Once the radio links have been established, they will be in the in-sync or out-of-sync states as shown in figure 1 in subclause 4.3.2.1. Transitions between those two states are described below.

The uplink radio link failure/restore criteria is based on the synchronisation status primitives CPHY-Sync-IND and CPHY-Out-of-Sync-IND, indicating in-sync and out-of-sync respectively.

When the radio links is are in the in-sync state, Node B shall start timer T_RLFAILURE after receiving N_OUTSYNC_IND consecutive out-of-sync indications. Node B shall stop and reset timer T_RLFAILURE upon receiving successive N_INSYNC_IND in-sync indications. If T_RLFAILURE expires, Node B shall trigger the RL Failure procedure and indicate which radio links are out-of-sync. When the RL Failure procedure is triggered, the radio links' state changes to the out-of-sync state.

When the radio links are in the out-of-sync state, after receiving N_INSYNC_IND successive in-sync indications Node B shall trigger the RL Restore procedure and indicate which radio links have re-established synchronisation. When the RL Restore procedure is triggered, the radio links' state changes to the in-sync state.

The specific parameter settings (values of T_RLFAILURE, N_OUTSYNC_IND, and N_INSYNC_IND) are configurable, see TS 25.433.

4.5 Discontinuous transmission (DTX) of Radio Frames

Discontinuous transmission (DTX) is applied in up- and downlink when the total bit rate after transport channel multiplexing differs from the total channel bit rate of the allocated dedicated physical channels.

Rate matching is used in order to fill resource units completely, that are only partially filled with data. In the case that after rate matching and multiplexing no data at all is to be transmitted in a resource unit the complete resource unit is discarded from transmission. This applies also to the case where only one resource unit is allocated and no data has to be transmitted.

When DTX is applied in the uplink and after a period of $(N_OUTSYNC_IND / 2) - 1$ silent frames no data has to be transmitted, then a dummy-special burst should be generated and transmitted in the next possible frame.

This dummy-special burst should have the same slot format as the normal burst where DTX is used. The dummy-special burst is filled with an arbitrary bit pattern, contains a TFCI and TPC bits if inner loop PC is applied. The TFCI of the dummy-special burst should indicate that there is no data to be transmitted.