

Source: ITU Ad Hoc
Title: Revision of Recommendation ITU-R M.1079
Document for: Approval
Agenda Item: ?

The text in the Annex is a proposed contribution to be submitted to the next meeting of ITU-R Task Group 8/1 (Beijing May 31 to June 11) by an Individual Member. Task Group 8/1 is defining the Recommendations for International Mobile Telecommunications 2000 (IMT-2000).

TG 8/1 is starting a process of revision of Recommendation ITU-R M.1079 (Speech and voice-band data performance requirements for IMT-2000). The revised version should reflect progress made since 1994 in areas such as voice transmission quality and its application to network planning, new speech codecs and the current understanding of the radio interface technologies for IMT-2000. More importantly it should broaden its scope to encompass other services that are presently envisioned for IMT-2000. Among these services can be noted video, packet data (including Internet applications) and multimedia. QoS parameters should be defined for all applications. The use of IMT-2000 for fixed wireless access should also be considered.

TG 8/1 requests that any information concerning existing or forthcoming recommendations that could be of help in this work be made available to it. It is important to note that the schedule for this revision is tight, it should be completed in November 1999. Thus, it is of utmost importance that the requested information is provided to TG 8/1 before its next meeting in early June.

This contribution provides a proposed response from 3GPP to influence the work in TG8/1 on QoS related issues in a direction that benefits 3GPP.

[The attachment of the Annex, Tdoc C-99-063, should be replaced with the latest version, which is assumed to appear as an output from the TSGS2 QoS ad-hoc group meeting on 20 - 22 April 1999 and TSG-SA #3 on 26 - 28 April 1999.]

ANNEX

[NATIONAL ADMINISTRATION OR ITU MEMBER]¹

REVISION OF RECOMMENDATION ITU-R M.1079

1 INTRODUCTION

In the TG8/1 meeting in Fortaleza, Brasil, March 8-19, 1999, TG 8/1 decided to start a process of revision of Recommendation ITU-R M.1079 (Speech and voiceband data performance requirements for IMT-2000). The revised version should reflect progress made since 1994 in areas such as voice transmission quality and its application to network planning, new speech codecs and the current understanding of the radio interface technologies for IMT-2000. More importantly it should broaden its scope to encompass other services that are presently envisioned for IMT-2000. Among these services can be noted, video, packet data (including Internet applications) and multimedia.

ETSI Sub Technical Committee SMG 12 was preparing a Technical Report on QoS matters for UMTS, and this work has now been transferred to 3GPP. The latest version of this 3GPP Technical Report is attached for information and guidance to TG 8/1.

(Note: the latest version from 3GPP TSG SA WG2 work to be attached before the TG8/1 meeting in Beijing, May 31 – June 11).

2 PROPOSAL FROM 3GPP TO UTILISE ITS WORK ON QoS IN TG8/1

3GPP notes that the time schedule to finalise the revision work of M.1079 is rather tight. Bearing in mind the considerable amount of detailed work on this topic already undertaken within SDOs and 3GPP, the availability of expert resources and the intention of some countries to deploy IMT-2000 by 2001, 3GPP encourages TG8/1 to review and consider use of this 3GPP Technical Report on QoS in the revision work of M.1079.

¹ This contribution was developed in 3GPP TSG RAN

ANNEX

Tdoc C-99-063

ETSI SMG12

January 5, 1999

Heathrow, England

Title: UMTS QoS Technical Report

Source: Nokia

Version: 0.8

1. INTRODUCTION

This is an updated version of the UMTS QoS Technical Report document according to comments given in Montreux and via email.

1. TABLE OF CONTENTS

1.	TABLE OF CONTENTS.....	4
2.	INTELLECTUAL PROPERTY RIGHTS.....	6
3.	FOREWORD	6
4.	SCOPE.....	6
5.	NORMATIVE REFERENCES.....	6
6.	INFORMATIVE REFERENCES.....	7
7.	DEFINITIONS AND ABBREVIATIONS	7
7.1	DEFINITIONS	7
7.2	ABBREVIATIONS	7
8.	HIGH LEVEL REQUIREMENTS.....	9
8.1	END USER QoS REQUIREMENTS.....	9
8.2	GENERAL REQUIREMENTS FOR QoS	9
8.3	TECHNICAL REQUIREMENTS FOR QoS	9
9.	QoS CAPABILITIES OF RADIO INTERFACE.....	10
10.	QoS ARCHITECTURE.....	10
10.1	OVERVIEW OF DIFFERENT LEVELS OF THE QoS	10
10.2	QoS MANAGEMENT FUNCTIONS IN THE NETWORK	11
10.2.1	<i>Monitor.....</i>	<i>12</i>
10.2.2	<i>Translator/Mapper.....</i>	<i>12</i>
10.2.3	<i>Policer.....</i>	<i>12</i>
10.2.4	<i>Admission Controller</i>	<i>13</i>
10.2.5	<i>Resource Manager</i>	<i>13</i>
10.3	UMTS QoS CLASSES	13
10.3.1	<i>Conversational class</i>	<i>14</i>
10.3.2	<i>Streaming class</i>	<i>15</i>
10.3.3	<i>Interactive class.....</i>	<i>15</i>
10.3.4	<i>Background class</i>	<i>16</i>
10.4	QoS PARAMETERS.....	16
10.4.1	<i>UMTS QoS Parameters</i>	<i>16</i>
10.4.2	<i>Bearer Service Parameters</i>	<i>16</i>
10.4.3	<i>Radio Access Bearer Parameters.....</i>	<i>16</i>
10.4.4	<i>Radio Bearer Parameters.....</i>	<i>17</i>
10.4.5	<i>Iu Bearer Parameters.....</i>	<i>17</i>

10.4.6	<i>Gn Bearer Parameters</i>	17
11.	QOS PARAMETER MAPPING	17
11.1	FROM APPLICATION PARAMETER TO UMTS QoS PARAMETER.....	17
11.2	FROM UMTS QoS PARAMETER TO BEARER SERVICE QoS PARAMETER.....	17
11.3	FROM BEARER SERVICE QoS PARAMETER TO RADIO ACCESS BEARER QoS PARAMETER	17
11.4	FROM RADIO ACCESS BEARER QoS PARAMETER TO RADIO BEARER QoS PARAMETER.....	17
11.5	FROM RADIO ACCESS BEARER QoS PARAMETER TO IU BEARER QoS PARAMETER	17
12.	QOS IN CONNECTION SETUP	17
13.	INTERWORKING	18
13.1	UMTS-GSM CS/GPRS.....	18
13.1.1	<i>UMTS-GSM CS</i>	18
13.1.2	<i>UMTS-GPRS</i>	18
13.2	UMTS-PSTN	20
13.3	UMTS-ISDN.....	20
13.4	UMTS-INTERNET	20
13.4.1	<i>UMTS-Integrated Services</i>	20
13.4.2	<i>UMTS-Differentiated Services</i>	21
14.	APPENDIX A INFORMATIVE ANNEX OF ATM	24

INTELLECTUAL PROPERTY RIGHTS

IPRs essential or potentially essential to the present deliverable may have been declared to ETSI. The information pertaining to these essential IPRs, if any, is publicly available for **ETSI members and non-members, free of charge**. This can be found in the latest version of the ETSI Technical Report: ETR 314: "Intellectual Property Rights (IPRs); Essential or potentially Essential, IPRs notified to ETSI in respect of ETSI standards". The most recent update of ETR 314, is available on the ETSI web server or on request from the Secretariat.

Pursuant to the ETSI Interim IPR Policy, no investigation, including IPR searches, has been carried out by ETSI. No guarantee can be given as to the existence of other IPRs not referenced in the ETR 314, which are, or may be, or may become, essential to the present document.

FOREWORD

SCOPE

Scope of this document is to provide the framework for Quality of Service in UMTS. The document shall be used as a living document which will cover all issues related Quality of Service in UMTS.

NORMATIVE REFERENCES

References may be made to:

- a) specific versions of publications (identified by date of publication, edition number, version number, etc.), in which case, subsequent revisions to the referenced document do not apply; or
- b) all versions up to and including the identified version (identified by " up to and including" before the version identity); or
- c) all versions subsequent to and including the identified version (identified by "onwards" following the version identity); or
- d) publications without mention of a specific version, in which case the latest version applies.

[1] UMTS 23.10 version 0.8.1, Universal Mobile Telecommunications System (UMTS), UMTS Access Stratum - Services and Functions

[2] UMTS 22.25 version 3.1.0, Universal Mobile Telecommunication System (UMTS), Quality of Service and Network Performance

- [3] UMTS 22.01 version 3.2.1, Universal Mobile Telecommunications System (UMTS), Service aspects, Service principles
- [4] UMTS 22.60 version 3.0.0, Universal Mobile Telecommunications System (UMTS), Service aspects, Mobile multimedia services including mobile Intranet and Internet services
- [5] UMTS 21.06, Network and Service Management Requirements for UMTS
- [6] UMTS 23.20 version 0.7.0, Evolution of the GSM platform towards UMTS

INFORMATIVE REFERENCES

- [1] Working assumption on Radio Access Bearer Services, Version: 0.0.2, Date: 14 May 1998
- [2] ETSI SMG12 TDoc 98s721, Rome, Italy, 14 - 18 September, 1998, Source: Editor (Ericsson), Draft 0.0.7 of Requirements Relevant for UTRAN Architecture
- [3] ETSI SMG12 TDoc 98s767, Rome, Italy, 14 - 18 September, 1998, Source: Motorola, Change request No. A086 rev.1
- [4] ETSI SMG12 TDoc 98s754, Rome, Italy, 14 - 18 September, 1998, Source: Lucent Technologies, Proposal for ETE UMTS QoS Control Principles
- [5] ETSI SMG12 TDoc 98s790, Rome, Italy, 14 - 18 September, 1998, Source: Motorola, QoS Profile Parameters
- [6] ATM Traffic Management Specification Version 4.0 [TM 4.0]
- [7] ATM User-Network Intercafe (UNI) Signalling Specification Version 4.0 [UNI 4.0]
- [8] ETSI SMG12 Tdoc 98s789, Rome, Italy, 14-18 September, 1998, Source: Motorola, Enhancements to Radio Bearer Parameters

DEFINITIONS AND ABBREVIATIONS

Definitions

For the purpose of this document the following definitions apply.

Abbreviations

For the purpose of this document the following abbreviations apply.

3G	3 rd Generation
AAL2	ATM Adaptation Layer 2
AAL5	ATM Adaptation Layer 5
ABR	Available Bit Rate
ATM	Asynchronous Transfer Mode
CDMA	Code Division Multiple Access
CBR	Constant Bit Rate
CS	Circuit Switched
GPRS	General Packet Radio Service
GSM	Global System for Mobile Communication
GTP	GPRS Tunneling Protocol
HO	Handover
IP	Internet Protocol
ISDN	Integrated Services Digital Network
L1	Layer 1, physical layer
L2	Layer 2, link layer
L3CE	Layer 3 Compatibility Entity
LLC	Logical Link Control
MAC	Medium Access Control
MCR	Minimum Cell Rate
MO	Mobile Originating Call
MS	Mobile Station
MT	Mobile Terminating Call
nrt	non-real time
NSAP	Network Service Access Point
NT	Non-Transparent
PCR	Peak Cell Rate
PDP	Packet Data Protocol
PSTN	Public Switched Telephone Network
QoS	Quality of Service
RAB	Radio Access Bearer
RAN	Radio Access Network
RLC	Radio Link Control
RSVP	Resource Reservation Protocol
rtreal time	
SAP	Service Access Point
SDU	Service Data Unit
UBR	Unspecified Bit Rate
UDP	User Datagram Protocol
TTransparent	
TCP	Transmission Control Protocol
TD-CDMA	Time Division CDMA
TE	Terminal Equipment
UMTS	Universal Mobile Telecommunication System
VBR	Variable Bit Rate
WCDMA	Wideband CDMA

HIGH LEVEL REQUIREMENTS

End User QoS Requirements

Generally, end users care only the issues that are visible to them. The involvement of the user leads to the following conclusions. From the end-user point of view:

- Only the QoS perceived by end-user matter.
- The number of user defined/controlled parameters has to be as small as possible.
- Derivation/definition of QoS attributes from the application requirements has to be simple.
- QoS attributes must be able to support all applications that are used.
- QoS definitions have to be future proof.
- QoS has to be provided end-to-end.

General Requirements for QoS

- QoS parameters (or mapping of them) should not be restricted to one or few external QoS control mechanisms but the QoS concept should be capable of providing different levels of QoS by using UMTS specific control mechanisms (not related to QoS mechanisms in the external networks).
 - All parameters have to have unambiguous meaning.
 - QoS mechanism have to allow efficient use of radio capacity.
 - Allow independent evolution of Core and Access networks
 - Allow evolution of UMTS network, (i.e., eliminate or minimise the impact of evolution of transport technologies in the wireline world)
 - All parameter combinations have to have unambiguous meaning.

Technical Requirements for QoS

This chapter presents the general high-level technical requirements for the UMTS QoS. QoS will be defined with a set of parameters. These parameters should meet the following criteria:

- UMTS QoS control mechanisms shall provide QoS parameter control on a peer to peer basis between MS and 3G gateway node.
- The UMTS QoS mechanisms shall provide a mapping between application requirements and UMTS services.

- The UMTS QoS control mechanisms shall be able to efficiently interwork with current QoS schemes. Further, the QoS concept should be capable of providing different levels of QoS by using UMTS specific control mechanisms (not related to QoS mechanisms in the external networks).
- A session based approach needs to be adopted for all packet mode communication within the 3G serving node with which UMTS QoS approach must be intimately linked, essential features are multiple QoS streams per address.
- The UMTS shall provide a finite set of QoS definitions.
- The overhead and additional complexity caused by the QoS scheme should be kept reasonably low, as well as the amount of state information transmitted and stored in the network.
- QoS shall support efficient resource utilisation.
- Applications (or special software in MS or 3G gateway node) should be able to indicate QoS values for their data transmissions.
- QoS behaviour should be dynamic , i.e., it shall be possible to modify QoS parameters during an active session.
- Number of parameters should be kept reasonably low (increasing number of parameters, increase system complexity).

QOS CAPABILITIES OF RADIO INTERFACE

[Editor note: This chapter shall describe the L1 from the QoS point of view. The intent of the chapter is to provide background to compare e.g. RAB parametrisations against L1 i.e. is L1 capable of utilising developed QoS concept.]

QOS ARCHITECTURE

Overview of Different Levels of the QoS

[Editor note: This chapter shall present different levels of QoS within UMTS network. The intent of the chapter is to clarify vocabulary and enable referring to same QoS level when discussing or proposing something. Current text in this chapter is proposed by Nokia and some sub-chapter names are based on this division.]

The QoS provided by the UMTS network can be divided to several levels. This chapter illustrates the different levels. These definitions shall be used for decreasing misunderstandings and they do not restrict implementations.

Error! Reference source not found. presents the UMTS user plane and user plane protocols in each network entity (in this presentation packet service is used as an example). UMTS QoS is presented in **Error! Reference source not found.** The aspects related to UMTS QoS mean one-way QoS within UMTS network between MS and 3G gateway node. This level of QoS is the highest that UMTS network alone can control/provide.

The next lower layer of QoS can be defined as bearer service QoS (**Error! Reference source not found.**). The parameters and QoS issues are defined up to the bottom of the L3CE layer. This level of QoS is the one that individual data flows experience between MS and core network (closest edge node from RAN).

One step lower from the bearer service QoS can be defined as radio access bearer QoS. Radio access bearer QoS involves layers and related parameters up to the bottom of the LLC (or corresponding protocol). Finally, bearer QoS can be divided to three different aspects: radio bearer QoS (**Error! Reference source not found.**), Iu bearer QoS (**Error! Reference source not found.**) and Gn bearer QoS (**Error! Reference source not found.**).

[Editor note: Protocols that are presented in figure are not agreed but they are used for simplifying illustration of different levels of QoS.]

Figure **Error! Style not defined.**-**Error! Bookmark not defined.** Different levels of QoS in UMTS network

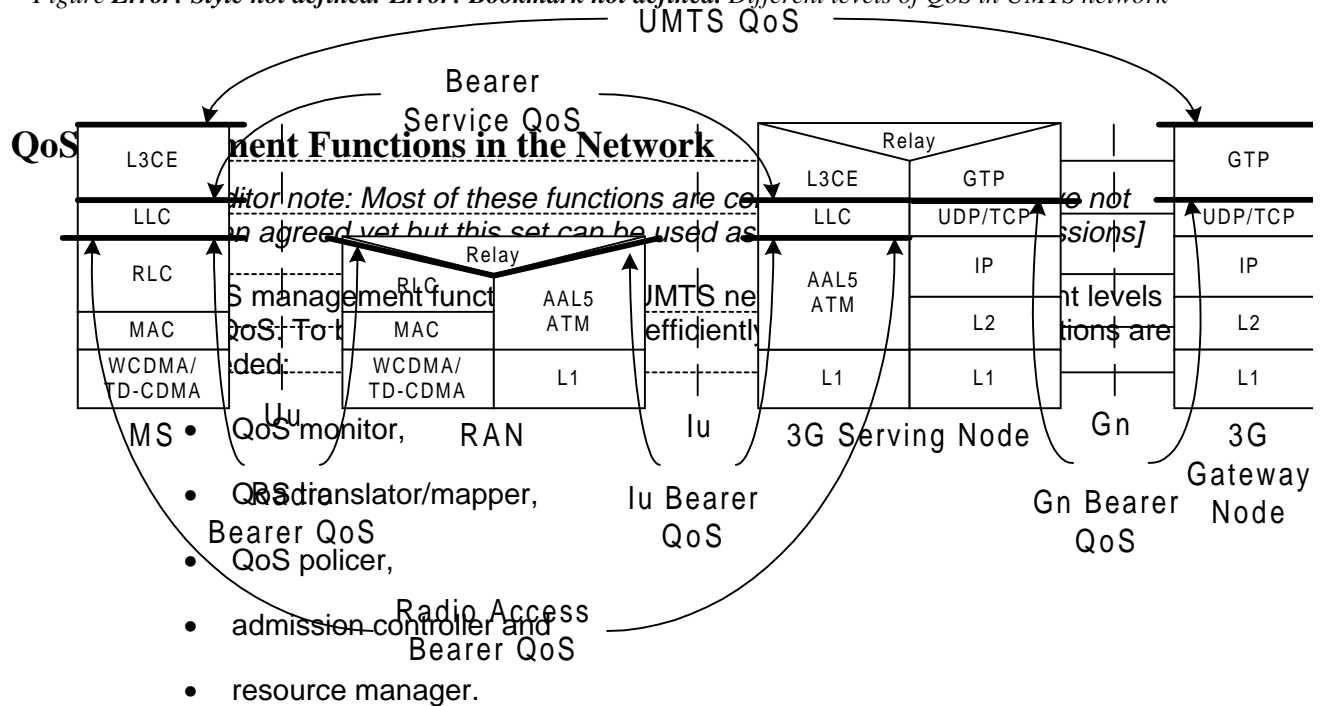

These functions (or part of them) can be combined to look like one entity if that will be seen feasible during standardisation. The tasks and functionality of these functions will be presented in following chapters. Further study is required to determine which of these functions must be standardized. Locations of the QoS management functions is presented in the **Error! Reference source not found.**

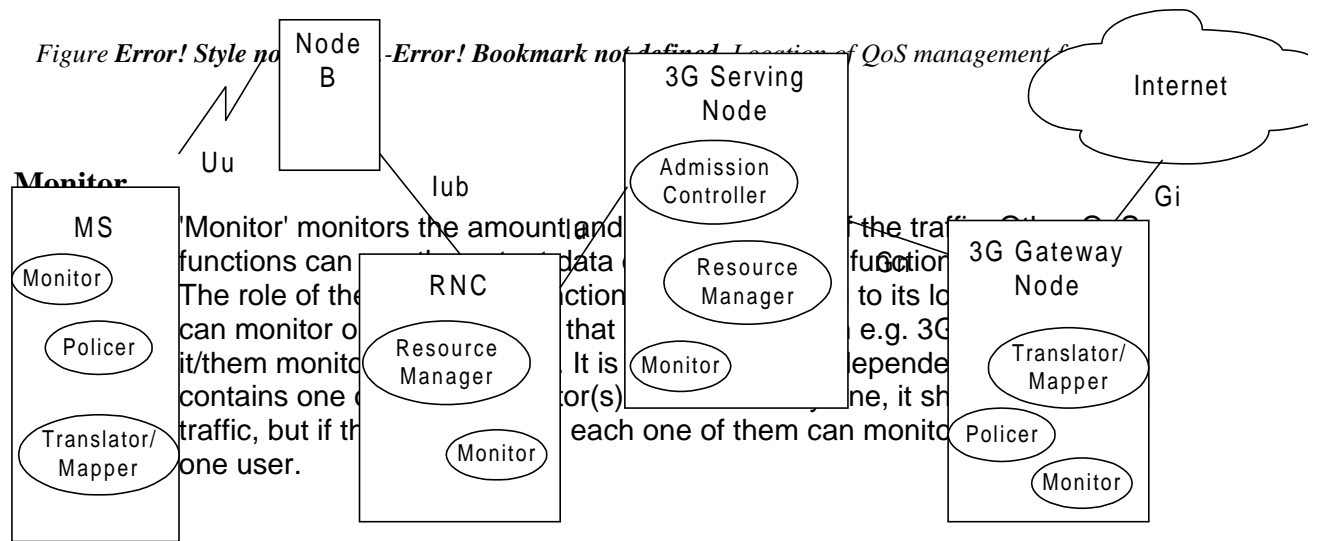

Translator/Mapper

Translator/mapper function locates in the MS and in 3G gateway node (there might be a need to have translator/mapper functions in other network elements, too). The main task of the translator/mapper function is to convert external QoS requirements to the form understandable to the UMTS network. The input for the translator/mapper function is a set of parameters from the 'external world'. The translator/mapper function derives parameters related to

- UMTS QoS,
- bearer service,
- radio access bearer,
- radio bearer,
- Iu bearer and
- Gn bearer

The translator/mapper function has to be designed to be capable of converting e.g. RSVP, ATM and differentiated services parameters to different parameters in UMTS. However, the function may not be restricted only to mentioned QoS mechanisms.

Policer

Policer function locates at the edge nodes (MS and 3G gateway node) of the UMTS network. Its main task is to control the traffic such that it will meet (or be 'less' than) the requested traffic characteristics e.g. traffic may not exceed the maximum negotiated bitrate. Policer drops or marks the packets that are determined to be non-compliant.

Policer function at 3G gateway node performs downlink data policing. In MS policer function performs uplink data policing.

Admission Controller

The purpose of admission control function is to calculate which network resources are required to provide requested QoS, determine if those resources are available, and reserve those resources. Admission control is performed in association with radio resource management functions in order to estimate the radio resource requirements within each cell.

The admission controller receives requests to allocate resources for a data flow. Each data flow is characterised by:

- its traffic characteristics (e.g. maximum bit rate, minimum bit rate) and
- requested QoS parameters (e.g. error rate).

The admission controller maintains:

- a record of all currently active data flows and
- a record of the total available resources available

Using above information the admission control function determines if the demands of a data flow request can be satisfied. Note that the resource scheduling policies being used by the resource scheduler must be taken into account by the admission controller.

The admission controller can be regarded as a mathematical function that takes as input traffic characteristics, requested QoS, current network element states, total resources available and resource scheduling policy and returns a yes or no answer.

Resource Manager

The resource manager is in charge of determining if the QoS requirements of a data flow can be satisfied and allocating resources to incoming packets. Occasionally, one or more packets will have to be discarded due to either lack of buffer capacity or excessive delays. The resource manager takes into account the QoS associated with various packets.

UMTS QoS Classes

When defining the UMTS QoS classes the restrictions and limitations of the air interface have to be taken into account. It is not reasonable to define complex mechanisms as have been in fixed networks due to different error characteristics of the air interface. The QoS mechanisms provided in the cellular network have to be robust and capable of providing reasonable QoS resolution. Table 10-1 illustrates proposed QoS classes for UMTS. UMTS offers these QoS classes to UMTS user (UMTS user defined in figure 10-3).

[Editor note: Protocols that are presented in figure are not agreed but they are used for simplifying illustration of different levels of QoS.]

Figure 10-3 The interface to which UMTS user is attached

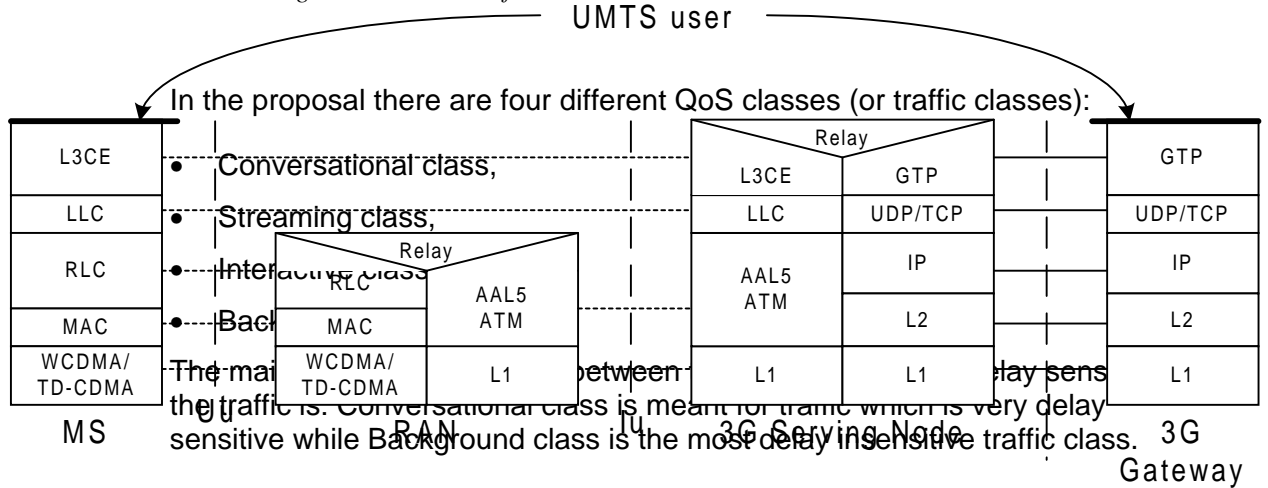

Conversational and Streaming classes are mainly intended to be used to carry real-time traffic flows. The main divider between them is how delay sensitive the traffic is. Conversational real-time services, like video telephony, are the most delay sensitive applications and those data streams should be carried in Conversational class.

Interactive class and Background are mainly meant to be used by traditional Internet applications like WWW, Email, Telnet, FTP and News. Due to looser delay requirements, compare to conversational and streaming classes, both provide better error rate by means of channel coding and retransmission. The main difference between Interactive and Background class is that Interactive class is mainly used by interactive applications, e.g. interactive Email or interactive Web browsing, while Background class is meant for background traffic, e.g. background download of Emails or background file downloading. Responsiveness of the interactive applications is ensured by separating interactive and background applications. Traffic in the Interactive class has higher priority in scheduling than Background class traffic, so background applications use transmission resources only when interactive applications do not need them. This is very important in wireless environment where the bandwidth is low compared to fixed networks.

Conversational class

The most well known use of this scheme is telephony speech (e.g. GSM). But with Internet and multimedia a number of new applications will require this scheme, for example voice over IP and video conferencing tools. Real time conversation is always performed between peers (or groups) of live (human) end-users. This is the only scheme where the required characteristics are strictly given by human perception.

Real time conversation scheme is characterised by that the transfer time must be low because of the conversational nature of the scheme and at the same time that the time relation (variation) between information entities of the stream must be preserved in the same way as for real time streams. The maximum transfer delay is given by the human perception of video and audio conversation. Therefore the limit for acceptable transfer delay is very strict, as

failure to provide low enough transfer delay will result in unacceptable lack of quality. The transfer delay requirement is therefore both significantly lower and more stringent than the round trip delay of the interactive traffic case.

Real time conversation - fundamental characteristics for QoS:

- preserve time relation (variation) between information entities of the stream
- conversational pattern (stringent and low delay)

Streaming class

When the user is looking at (listening to) real time video (audio) the scheme of real time streams applies. The real time data flow is always aiming at a live (human) destination. It is a one way transport.

This scheme is one of the newcomers in data communication, raising a number of new requirements in both telecommunication and datacommunication systems. It is characterised by that the time relations (variation) between information entities (i.e. samples, packets) within a flow must be preserved, although it does not have any requirements on low transfer delay.

The delay variation of the end-to-end flow must be limited, to preserve the time relation (variation) between information entities of the stream. But as the stream normally is time aligned at the receiving end (in the user equipment), the highest acceptable delay variation over the transmission media is given by the capability of the time alignment function of the application. Acceptable delay variation is thus much greater than the delay variation given by the limits of human perception.

Real time streams - fundamental characteristics for QoS:

- preserve time relation (variation) between information entities of the stream

Interactive class

When the end-user, that is either a machine or a human, is on line requesting data from remote equipment (e.g. a server), this scheme applies. Examples of human interaction with the remote equipment are: web browsing, data base retrieval, server access. Examples of machines interaction with remote equipment are: polling for measurement records and automatic data base enquiries (tele-machines).

Interactive traffic is the other classical data communication scheme that on an overall level is characterised by the request response pattern of the end-user. At the message destination there is an entity expecting the message (response) within a certain time. Round trip delay time is therefore one of the key attributes. Another characteristic is that the content of the packets must be transparently transferred (with low bit error rate).

Interactive traffic - fundamental characteristics for QoS:

- request response pattern
- preserve payload content

Background class

When the end-user, that typically is a computer, sends and receives data-files in the background, this scheme applies. Examples are background delivery of E-mails, SMS, download of databases and reception of measurement records.

Background traffic is one of the classical data communication schemes that on an overall level is characterised by that the destination is not expecting the data within a certain time. The scheme is thus more or less delivery time insensitive. Another characteristic is that the content of the packets must be transparently transferred (with low bit error rate).

Background traffic - fundamental characteristics for QoS:

- the destination is not expecting the data within a certain time
- preserve payload content

Table 10-1 UMTS QoS classes

Traffic class	Conversational class conversational RT	Streaming class streaming RT	Interactive class Interactive best effort	Background Background best effort
Fundamental characteristics	<ul style="list-style-type: none"> • Preserve time relation (variation) between information entities of the stream • Conversational pattern (stringent and low delay) 	<ul style="list-style-type: none"> • Preserve time relation (variation) between information entities of the stream 	<ul style="list-style-type: none"> • Request response pattern • Preserve payload content 	<ul style="list-style-type: none"> • Destination is not expecting the data within a certain time • Preserve payload content
Example of the application	- voice	- streaming video	- Web browsing	- background download of emails

QoS Parameters

UMTS QoS Parameters

Bearer Service Parameters

Radio Access Bearer Parameters

Radio Bearer Parameters

Iu Bearer Parameters

Gn Bearer Parameters

QOS PARAMETER MAPPING

[Editor note: This chapter shall contain information of parameter mapping i.e. how parameter in different levels of QoS (from external world and within UMTS network) shall be mapped. Current sub-chapter division is based on an assumption that levels of QoS presented in chapter Overview of Different Levels of the QoS, but they are open to discussions.]

From Application Parameter to UMTS QoS Parameter

From UMTS QoS Parameter to Bearer Service QoS Parameter

From Bearer Service QoS Parameter to Radio Access Bearer QoS Parameter

From Radio Access Bearer QoS Parameter to Radio Bearer QoS Parameter

From Radio Access Bearer QoS Parameter to Iu Bearer QoS Parameter

QOS IN CONNECTION SETUP

[Editor note: This chapter shall contain information of QoS parameters when setting up a PDP context, bearer, etc.]

INTERWORKING

The model for the UMTS QoS classes and parameters may not be any existing network or QoS protocol/mechanisms as such. The main goal of the specification is not to copy existing QoS mechanisms but rather to create a future proof concept that will provide means to transport different types of data with different QoS requirements. Thus the interworking of UMTS and existing network technologies has to be ensured. This chapter presents the most common technologies that UMTS shall be capable to interwork with.

UMTS-GSM CS/GPRS

The development of the GSM/GPRS QoS classes and parameters is going on.

UMTS-GSM CS

The mapping between UMTS-GSM CS is easy because in GSM CS services only channel type (NT/T) and bandwidth (number of used time slots) can vary. During handover between UMTS-GSM only reliability, delay and bandwidth are meaningful parameters.

HO from UMTS to GSM:

Reliability and delay together determines if NT or T service is used. Bandwidth is mapped to the next higher possible step.

HO from GSM to UMTS:

Type of service determines the required reliability. Bandwidth is mapped to the next higher possible step.

UMTS-GPRS

[Editor note: Part of GPRS phase 1 QoS are vaguely defined. This chapter has to be updated according to CRs to GPRS phase 1 QoS parameters. Definition of GPRS phase 2 is starting and it has to be taken into account in here and vice versa.]

GPRS has more QoS parameters than GSM CS thus requiring more complex mapping rules. Below an example of mapping GPRS phase 1 QoS parameters to UMTS traffic classes is presented.

Conversational Class

Conversational class services are mainly for conversational real time use. An example of conversational real time application is video telephony.

An appropriate use of GPRS parameters:

- Mean Throughput Class = Peak bit rate (constant bit rate)

Or Mean Throughput Class < Peak bit rate (variable bit rate)

- Reliability: 4 or 5 (no retransmissions)
- Precedence: 1-3
- Delay Class: 1 (real time)

Streaming Class

Streaming class services are mainly appropriate for streaming real time applications, e.g. video downloading. Some variation in delay can be tolerated because of application level buffering.

An appropriate use of GPRS parameters:

- Mean Throughput Class = Peak bit rate (constant bit rate)

Or Mean Throughput Class < Peak bit rate (variable bit rate)

- Reliability: 3 (light retransmissions)
- Precedence: 1-3
- Delay Class: 1 (real time)

Interactive Class

Interactive class services are mainly for interactive services requiring a variable guaranteed throughput: specialized applications (banking, plane reservation, ...), interactive WWW, Telnet etc.

An appropriate use of GPRS parameters:

- Mean Throughput Class has no meaning in UMTS
- Reliability: 1-2
- Precedence: 1-3
- Delay class: 2-4

Background Class

Background services are mainly for best effort services: background download, emails, calendar, event etc.

An appropriate use of GPRS parameters:

- Mean Throughput Class has no meaning in UMTS
- Reliability: 2
- Precedence: 1-3
- Delay class: 4 (best effort)

UMTS-PSTN

PSTN does not have QoS mechanisms thus QoS parameter interworking/mapping is not needed. However, means for determining required bandwidth, delay and reliability has to be developed. It is simple in MO cases but in MT cases the mechanisms (or in worst case defaults) have to be developed.

UMTS-ISDN

ISDN does not have QoS mechanisms thus QoS parameter interworking/mapping is not needed. However, means for determining required bandwidth, delay and reliability has to be developed. It is simple in MO cases but in MT cases the mechanisms (or in worst case defaults) have to be developed.

UMTS-Internet

In the case of Internet applications, the selection of the class and appropriate traffic attribute values is made according to the Internet QoS parameters. Internet applications do not directly use the services of UMTS but they use Internet QoS definitions and attributes, which are mapped to UMTS QoS attributes at API. Currently there are two main Internet QoS concepts, namely Integrated Services and Differentiated Services. The mapping between Internet QoS and UMTS QoS is presented in following chapters.

IP based QoS models must be supported for PDP contexts, meaning both Integrated Services (IntServ) signalled by RSVP [RFC2205] and Differentiated Services (6-bit QoS parameter on each IP packet, DiffServ). Both mechanisms are controlled by applications residing in the TE, allowing different application specific QoS levels for the same PDP context. Application level IP based QoS must be mapped to UMTS packet core QoS by a network element at the border of the network, such as the 3G gateway node. RSVP support would require flow establishment, and possibly aggregation of flows, within the UMTS packet core network. Differentiated services would require that there is either one QoS profile for each traffic type or alternatively the priority and traffic type information is included in the data packets.

UMTS-Integrated Services

RSVP is an end-to-end control protocol for Integrated Services Architecture and requires (soft) connection state maintenance in each network element along the data path.

UMTS-Differentiated Services

Work in IETF focuses on Differentiated services where the plan is to specify the details of IP header bit usage for QoS differentiated classes of service. Proposals in the IETF include varying number of pre-defined bits for delay and dropping priorities allowing each packet to be handled independently based on the header bits. The main objective is to specify only a QoS mechanism into header fields rather than end-to-end flow management.

APPENDIX NOKIA PROPOSED TEXT FOR DIFFERENT CHAPTERS

[Editor note: Text proposed for different chapters should be discussed separately from the skeleton of the document. Further, the proposed text for different chapters should be discussed, accepted or rejected chapter by chapter]

10.4.1 UMTS QoS Parameters

One of the key issues mentioned in the previous chapters is that parameter set has to be kept as small and simple as possible. Following set of parameters have been identified meet the criteria mentioned previously.

1. **Delay**, gives an indication of the type of the traffic. It gives an indication of the needed resource requirements i.e. strict delay class⇒fixed reservation of resources and describes means for achieving requested error rate. It also sets the limits to the error rate i.e. if strict delay class is requested e.g. retransmission cannot be used. Delay class parameter will be more dominating over error rate.
2. **Error rate**, effects to the selection of the channel coding method, retransmission and/or power control.
3. **Maximum bitrate**, indicates the maximum requested capacity. If this parameter has the same value as minimum bitrate the service will be constant rate and resources according to maximum bitrate are guaranteed. This parameter does not have meaning in Interactive and Background classes.
4. **Minimum bitrate**, indicates the reserved capacity and the resources are guaranteed. If this parameter has same value as maximum bitrate the service will be constant rate service. This parameter does not have meaning in Interactive and Background classes. (FFS)
5. **Priority**, has effect to the admission control, to the retention control and to the traffic handling.

The usage of different parameters has been defined in Table 10-2.

Table 10-2 UMTS QoS classes and required parameters

Traffic class	Conversational class conversational RT	Streaming class streaming RT	Interactive class Interactive best effort	Background Background best effort
Delay class	X	X	X	X
Error Rate	X	X	X	X

Max bitrate	X	X	-	-
Min bitrate, FFS	X	X	-	-
Priority	X	X	X	X

APPENDIX A INFORMATIVE ANNEX OF ATM

ATM relies on a homogenous network with a unified data unit – ATM cell – and QoS guarantees are achieved with a statistical multiplexing.

The current set of ATM service categories and relevant parameters as defined by the ATM Forum is introduced below.

The relevant ATM Forum documents are [12] and [13].

A.1 ATM Service Categories

ATM networks offer a specific set of service categories which define the service characteristics and related parameters for different types of connections. At connection set-up, the user must request a specific service category for the connection from the network. The current set of service categories defined by the ATM Forum in the Traffic Management Specification 4.0, are:

- **Constant Bit Rate (CBR):** The CBR service category is used by connections that require a static amount of bandwidth during the whole time of the connection. CBR service is intended to support real-time applications requiring tightly constrained delay variation. CBR is typically used for circuit emulation.
- **Real-Time Variable Bit Rate (rt-VBR):** The rt-VBR service category is intended for real time applications which require small delay and a fixed timing relationship between samples. Therefore, rt-VBR service category is appropriate, e.g., for transmission of voice and video.
- **Non-Real-Time Variable Bit Rate (nrt-VBR):** The nrt-VBR service category is intended for non-real-time applications which have bursty traffic characteristics. No delay bounds are associated with this service category.
- **Available Bit Rate (ABR):** ABR supports variable bit rate traffic and does not provide any timing relationship between source and destination. Therefore, ABR is not intended to support real-time applications. In ABR, the network provides a “best effort” service, in which feedback (using a flow control mechanisms) is used to adjust the user bandwidth to the appropriate value which can vary between Minimum Cell Rate (MCR) and Peak Cell Rate (PCR).
- **Unspecified Bit Rate (UBR):** The UBR service category does not specify traffic related service guarantees. The user is free to send any amount of data while the network makes no guarantees on the cell loss rate, delay or delay variation that might be experienced. Thus, UBR is intended for non-real-time applications, such as file transfer and email.

The service categories can be distinguished as being either real-time or non-real-time. For real-time traffic, there are two categories: CBR and rt-VBR,

distinguished by the degree to which the delay variation between the cells is expected and preserved by the network.

The three non-real-time categories, nrt-VBR, ABR and UBR, differ as to the nature of the service guarantees provided by the network (regarding cell loss and delay) and the mechanisms which are implemented in end-systems and networks to realise them.

The requirements imposed by real-time and non-real-time services are different. The main difference between the two types is in terms of delay tolerance. Real-time services will have stringent requirements on delay and/or delay variation while non-real-time services may experience longer transfer delays. This in turn means that the buffers used for real-time services must be kept small in order to avoid long buffering delays and cells for real time connections must therefore be given high priority, i.e. routed quickly through the switches. On the other hand, buffers for non-real-time services have to be large so that non-real-time cells can be queued during the transmission of higher priority real-time service cells.

A.2 Traffic and QoS Parameters

In addition to the service category a user must, at connection set-up, inform the network of both the expected nature of the traffic that will be sent along the connection, as well as the quality of service (QoS) required for the connection. The former is described by a set of traffic parameters, while the latter is specified by a set of QoS parameters.

The way in which these parameters are agreed upon depends on the used specification. According to the ATM Forum UNI 3.1 specification [UNI 3.1], the user informs the network of desired traffic parameters and the service category (e.g. CBR). For UNI 3.1, the service category implicitly defines a set of (network operator selected) QoS parameters, each having a predefined value. Therefore, all connections having same service category will have the same QoS parameters.

UNI 4.0 [UNI 4.0], on the other hand, provides means to negotiate individual values also for the different QoS parameters. This makes it easier to adapt mobile systems into ATM networks, because it enables the possibility to take the varying quality of the air interface and the varying requirements of the applications into account in a more detailed manner.