

TSG-RAN Working Group 3, meeting #7
Sophia Antipolis, France, 20th – 24th September 1999

TSGR3#7(99)C20

Agenda Item: 10

Source: **Editor** (Nokia)

Title: Editor's Proposal for **25.413**

Document for: Approval

Note: Revision marks reflect the proposed changes.

3GPP

TS 25.413 V1.2.32 (1999-09)

Technical Specification

**3rd Generation Partnership Project (3GPP);
Technical Specification Group (TSG) RAN
UTRAN Iu Interface RANAP Signalling**

[UMTS 25.413]

3GPP



Reference

<Workitem> (<Shortfilename>.PDF)

Keywords

<keyword[, keyword]>

3GPP

Postal address

Office address

Internet

secretariat@3gpp.org

Individual copies of this deliverable
can be downloaded from

<http://www.3gpp.org>

Copyright Notification

No part may be reproduced except as authorized by written permission.
The copyright and the foregoing restriction extend to reproduction in all media.

©
All rights reserved.

Contents

Intellectual Property Rights	9
Foreword	9
1 Scope	9
2 References	9
3 Definitions and abbreviations	10
3.1 Definitions	10
3.2 Abbreviations	11
4 General	11
5 RANAP Services	11
6 Services expected from signalling transport	12
7 Functions of RANAP	12
8 RANAP procedures	13
8.1 Elementary Procedures	13
8.2 Radio Access Bearer Assignment	14
8.2.1 Normal operation	14
8.3 RAB Release Request	16
8.4 Iu Release Request	17
8.5 Iu Release	17
8.6 Relocation	18
8.6.1 General	18
8.6.2 Relocation Preparation	18
8.6.2.1 Successful operation	18
8.6.2.2 Unsuccessful operation	19
8.6.2.3 Relocation co-ordination in source RNC	19
8.6.3 Relocation resource allocation	20
8.6.3.1 Successful operation	20
8.6.3.2 Unsuccessful operation	20
8.6.3.3 Relocation co-ordination in target RNC	21
8.6.4 Relocation Detect	21
8.6.5 Relocation Complete	22
8.6.6 Relocation Cancel	22
8.7 Paging	23
8.8 Common Id	23
8.9 CN Invoke Trace	24
8.10 Cipher Mode Control	24
8.10.1 Successful operation	24
8.10.2 Unsuccessful operation	25
8.11 Location Reporting Control	25
8.11.1 Normal operation	26
8.11.2 Abnormal conditions	26
8.11.2.1 Abnormal conditions in RNC	26
8.12 Location Report	26
8.12.1 Successful operation	26
8.12.2 Unsuccessful operation	26
8.12.3 Abnormal conditions	27
8.12.3.1 Abnormal conditions in CN	27
8.13 Initial UE Message	27
8.14 Direct Transfer	27
8.15 CN Information Broadcast	28
8.16 Overload Control	28
8.16.1 General	28

8.16.2	Philosophy	28
8.16.3	Overload at the CN	29
8.16.4	Overload at the UTRAN	29
8.17	Reset	30
8.17.1	General	30
8.17.2	Reset at the UTRAN	30
8.17.3	Reset at the CN	30
8.17.4	Abnormal Conditions	31
8.17.4.1	Abnormal Condition at the UTRAN	31
8.17.4.2	Abnormal Condition at the CN	31
8.17.4.3	Crossing of Reset messages	31
8.18	Error Indication	31
8.18.1	General	31
8.18.2	CN originated Error Indication	31
8.18.3	RNC originated Error Indication	32
9	Elements for RANAP communication	32
9.1	Message contents	32
9.1.1	RAB ASSIGNMENT REQUEST	34
9.1.2	RAB ASSIGNMENT RESPONSE	34
9.1.3	RAB RELEASE REQUEST	35
9.1.4	IU RELEASE REQUEST	35
9.1.5	IU RELEASE COMMAND	35
9.1.6	IU RELEASE COMPLETE	36
9.1.7	RELOCATION REQUIRED	36
9.1.8	RELOCATION REQUEST	36
9.1.9	RELOCATION REQUEST ACKNOWLEDGE	37
9.1.10	RELOCATION COMMAND	37
9.1.11	RELOCATION DETECT	37
9.1.12	RELOCATION COMPLETE	37
9.1.13	RELOCATION PREPARATION FAILURE	37
9.1.14	RELOCATION FAILURE	38
9.1.15	RELOCATION CANCEL	38
9.1.16	RELOCATION CANCEL ACKNOWLEDGE	38
9.1.17	PAGING	38
9.1.18	COMMON ID	38
9.1.19	CN INVOKE TRACE	38
9.1.20	CIPHER MODE COMMAND	39
9.1.21	CIPHER MODE COMPLETE	39
9.1.22	CIPHER MODE REJECT	39
9.1.23	LOCATION REPORTING CONTROL	39
9.1.24	LOCATION REPORT	39
9.1.25	INITIAL UE MESSAGE	40
9.1.26	DIRECT TRANSFER	40
9.1.27	CN INFORMATION BROADCAST REQUEST	40
9.1.28	CN INFORMATION BROADCAST CONFIRM	40
9.1.29	CN INFORMATION BROADCAST REJECT	40
9.1.30	OVERLOAD	41
9.1.31	RESET	41
9.1.32	RESET ACKNOWLEDGE	41
9.1.33	ERROR INDICATION	41
9.2	Information element definitions	41
9.2.1	Radio network layer related IEs	42
9.2.1.1	Message type	42
9.2.1.2	RAB ID	42
9.2.1.3	RAB parameters	42
9.2.1.4	Cause	42
9.2.1.5	Priority level and pre-emption indication	42
9.2.1.6	RAB linking	42
9.2.1.7	Location Identifier	42
9.2.1.8	CN Domain Indicator	42

9.2.1.9	Trace Type	42
9.2.1.10	Trigger ID	42
9.2.1.11	Trace Reference	42
9.2.1.12	UE Identity	42
9.2.1.13	OMC ID	42
9.2.1.14	Encryption Information	43
9.2.1.15	Chosen Encryption Algorithm	43
9.2.1.16	Broadcast Area	43
9.2.1.17	Categorisation parameters	43
9.2.1.18	Request Type	43
9.2.1.19	Location Information	43
9.2.1.20	User Plane Mode	43
9.2.1.21	Paging Area ID	43
9.2.1.22	Source ID	43
9.2.1.23	Target ID	43
9.2.1.24	Source RNC to Target RNC Transparent Container	44
9.2.1.25	Target RNC to Source RNC Transparent Container	44
9.2.1.26	Number of steps	44
9.2.2	Transport network layer related IEs	44
9.2.2.1	Transport address	44
9.2.2.2	Iu transport association	44
9.2.3	NAS related IEs	44
9.2.3.1	NAS Binding Information	44
9.2.3.2	Permanent NAS Identity	44
9.2.3.3	IMSI	44
9.2.3.4	Temporary UE ID	44
9.2.3.5	Paging Cause	45
9.2.3.6	NAS Bit String	45
9.2.3.7	NAS PDU	45
9.2.3.8	NAS Layer 3 Information	45
9.3	Message and Information element abstract syntax (with ASN.1)	45
9.4	Message transfer syntax	47
9.5	Timers	47
10	Handling of unknown, unforeseen and erroneous protocol data	48
11	Annex A (normative):	48
Annex A	Document Stability Assessment Table	48
12	History	48
Intellectual Property Rights		9
Foreword		9
1	Scope	9
2	References	9
3	Definitions and abbreviations	10
3.1	Definitions	10
3.2	Abbreviations	11
4	General	11
5	RANAP Services	11
6	Services expected from signalling transport	12
7	Functions of RANAP	12
8	RANAP procedures	13
8.1	Elementary Procedures	13
8.2	Relocation	15
8.2.1	General	15

8.2.2	Relocation Preparation	16
8.2.2.1	Successful operation	16
8.2.2.2	Unsuccessful operation	16
8.2.2.3	Relocation co-ordination in source RNC	17
8.2.3	Relocation resource allocation	17
8.2.3.1	Successful operation	17
8.2.3.2	Unsuccessful operation	18
8.2.3.3	Relocation co-ordination in target RNC	18
8.2.4	Relocation Detect	19
8.2.5	Relocation Complete	20
8.2.6	Relocation Cancel	20
8.3	Radio Access Bearer Assignment	21
8.3.1	Normal operation	24
8.4	RAB Release Request	26
8.5	Iu Release Request	26
8.6	Iu Release	27
8.7	Overload Control	29
8.7.1	General	29
8.7.2	Philosophy	29
8.7.3	Overload at the CN	29
8.7.4	Overload at the UTRAN	30
8.8	Reset	30
8.8.1	General	30
8.8.2	Reset at the UTRAN	30
8.8.3	Reset at the CN	31
8.8.4	Abnormal Conditions	31
8.8.4.1	Abnormal Condition at the UTRAN	31
8.8.4.2	Abnormal Condition at the CN	31
8.8.4.3	Crossing of Reset messages	31
8.9	Common Id	31
8.10	Paging	32
8.11	CN Invoke Trace	33
8.12	Cipher Mode Control	33
8.12.1	Successful operation	33
8.12.2	Unsuccessful operation	34
8.13	CN Information Broadcast	35
8.14	Direct Transfer	35
8.15	Initial UE Message	36
8.16	Location Reporting Control	36
8.16.1	Normal operation	36
8.16.2	Abnormal conditions	37
8.16.2.1	Abnormal conditions in RNC	37
8.17	Location Report	37
8.17.1	Successful operation	37
8.17.2	Unsuccessful operation	37
8.17.3	Abnormal conditions	37
8.17.3.1	Abnormal conditions in CN	37
8.18	Error Indication	37
8.18.1	General	37
8.18.2	CN originated Error Indication	37
8.18.3	RNC originated Error Indication	38
9	Elements for RANAP communication	38
9.1	Message contents	38
9.1.1	RAB ASSIGNMENT REQUEST	39
9.1.2	RAB ASSIGNMENT RESPONSE	40
9.1.3	RAB RELEASE REQUEST	41
9.1.4	COMMON ID	42
9.1.5	DIRECT TRANSFER	42
9.1.6	INITIAL UE MESSAGE	42
9.1.7	LOCATION REPORTING CONTROL	42

9.1.8	LOCATION REPORT	42
9.1.9	CIPHER MODE COMMAND	43
9.1.10	CIPHER MODE COMPLETE	43
9.1.11	CIPHER MODE REJECT	43
9.1.12	PAGING	43
9.1.13	IU RELEASE COMMAND	43
9.1.14	IU RELEASE COMPLETE	44
9.1.15	IU RELEASE REQUEST	44
9.1.16	RELOCATION REQUIRED	44
9.1.17	RELOCATION REQUEST	44
9.1.18	RELOCATION REQUEST ACKNOWLEDGE	45
9.1.19	RELOCATION COMMAND	45
9.1.20	RELOCATION DETECT	45
9.1.21	RELOCATION COMPLETE	45
9.1.22	RELOCATION PREPARATION FAILURE	46
9.1.23	RELOCATION FAILURE	46
9.1.24	RELOCATION CANCEL	46
9.1.25	RELOCATION CANCEL ACKNOWLEDGE	46
9.1.26	RESET	46
9.1.27	RESET ACKNOWLEDGE	46
9.1.28	OVERLOAD	47
9.1.29	CN INVOKE TRACE	47
9.1.30	CN INFORMATION BROADCAST REQUEST	47
9.1.31	CN INFORMATION BROADCAST CONFIRM	47
9.1.32	CN INFORMATION BROADCAST REJECT	47
9.1.33	ERROR INDICATION	48
9.2	Information element definitions	48
9.2.1	Message type	51
9.2.2	RAB ID	51
9.2.3	NAS Binding Information	51
9.2.4	RAB parameters	51
9.2.5	Transport address	51
9.2.6	Iu transport association	51
9.2.7	Cause	51
9.2.8	Priority level and pre-emption indication	51
9.2.9	RAB linking	51
9.2.10	Location Identifier	51
9.2.11	Permanent NAS Identity	51
9.2.12	CN Domain Indicator	52
9.2.13	IMSI	52
9.2.14	Temporary UE ID	52
9.2.15	Paging Cause	52
9.2.16	Trace Type	52
9.2.17	Trigger ID	52
9.2.18	Trace Reference	52
9.2.19	UE Identity	52
9.2.20	OMC ID	52
9.2.21	Encryption Information	52
9.2.22	Chosen Encryption Algorithm	52
9.2.23	NAS Bit String	52
9.2.24	Broadcast Area	52
9.2.25	Categorisation parameters	53
9.2.26	NAS PDU	53
9.2.27	Request Type	53
9.2.28	Location Information	53
9.2.29	NAS Layer 3 Information	53
9.2.30	User Plane Mode	53
9.2.31	Paging Area ID	53
9.2.32	Source ID	53
9.2.33	Target ID	53

9.2.34	Source RNC to Target RNC Transparent Container	53
9.2.35	Target RNC to Source RNC Transparent Container	53
9.2.36	Number of steps.....	53
9.3	Message and Information element abstract syntax (with ASN.1).....	54
9.4	Message transfer syntax	56
9.5	Timers	56
10	Handling of unknown, unforeseen and erroneous protocol data.....	56
11	Annex A (normative):.....	57
	Annex A Document Stability Assessment Table	57
12	History	57

Intellectual Property Rights

Foreword

This Technical Specification has been produced by the 3rd Generation Partnership Project, Technical Specification Group <TSG name>.

The contents of this TS may be subject to continuing work within the 3GPP and may change following formal TSG approval. Should the TSG modify the contents of this TS, it will be re-released with an identifying change of release date and an increase in version number as follows:

Version m.t.e

where:

- m indicates [major version number]
- x the second digit is incremented for all changes of substance, i.e. technical enhancements, corrections, updates, etc.
- y the third digit is incremented when editorial only changes have been incorporated into the specification.

1 Scope

~~This present~~ document specifies the radio network layer signalling ~~procedures between RNC and CN, called~~ Radio Access Network Application Part (RANAP) for the Iu interface. RANAP supports the functions of Iu interface by signalling procedures defined in this document. RANAP is developed in accordance to the general principles stated in [1], [2] and [3].

2 References

[Editor's note: To be updated.]

The following documents contain provisions which, through reference in this text, constitute provisions of the present document.

- References are either specific (identified by date of publication, edition number, version number, etc.) or non-specific.
- For a specific reference, subsequent revisions do not apply.
- For a non-specific reference, the latest version applies.
- A non-specific reference to an ETS shall also be taken to refer to later versions published as an EN with the same number.

[1] UMTS 25.930, Iu Principles

[2] UMTS 25.410, UTRAN Iu Interface: General Aspects and Principles

[3] UMTS 25.401, UTRAN Overall Description

[4] UMTS 25.931, UTRAN Functions, Examples on Signalling Procedures

[5] UMTS 25.412, UTRAN Iu Interface Signalling Transport

[6] ~~UMTS 25.415, Iu Interface CN-UTRAN User Plane Protocols~~

[2] ~~UMTS 25.401, UTRAN Overall Description~~

3 Definitions and abbreviations

3.1 Definitions

For the purposes of the present document, the [following] terms and definitions [given in ... and the following] apply.

Relocation of SRNS: Relocation of SRNS is a UMTS functionality used to relocate the serving RNS role from one RNS to another RNS. This UMTS functionality is realised by several elementary procedures executed in several interfaces and by several protocols and it may involve a change in the radio resources used between UTRAN and UE.

It is also possible to relocate the serving RNS role from one RNS to another relocation target external to UMTS or functionality equivalent to the serving RNS role from another relocation source external to UMTS to another RNS.

Serving RNS (SRNS): A role an RNS can take with respect to a specific connection between an UE and UTRAN. There is one Serving RNS for each UE that has a connection to UTRAN. The Serving RNS is in charge of the radio connection between a UE and the UTRAN. The Serving RNS terminates the Iu for this UE.

Serving RNC (SRNC): SRNC is the RNC belonging to SRNS.

Source RNS: A role, with respect to a specific connection between an UE and UTRAN, that RNS takes when it decides to initiate a relocation of SRNS.

Source RNC: Source RNC is the RNC belonging to source RNS.

Target RNS: A role an RNS gets with respect to a specific connection between UE and UTRAN when it is being a subject of a relocation of SRNS which is being made towards that RNS.

Target RNC: Target RNC is the RNC belonging to target RNS.

Elementary Procedure: The RANAP protocol consists of Elementary Procedures (EPs). An Elementary Procedure is a unit of interaction between the RNS and the CN. An EP consists of an initiating message and possibly a response message. Three kinds of EPs are used:

- **Class 1:** Elementary Procedures with response (success or failure).
- **Class 2:** Elementary Procedures without response.
- **Class 3:** Elementary Procedures with possibility of multiple responses.

For Class 1 EPs, the types of responses can be as follows:

Successful

- A signalling message explicitly indicates that the elementary procedure successfully completed with the receipt of the response.
- An EP is performed as a response to the first EP.

Unsuccessful

- A signalling message explicitly indicates that the EP failed.
- On time supervision expiry (i.e. absence of expected response).

Class 2 EPs are considered always successful.

Class 3 EPs have one or several response messages reporting both successful, unsuccessful outcome of the requests and temporary status information about the requests. This type of EP only initiates and terminates through response(s) or EP timer expiry.

The following applies concerning interaction between Elementary Procedures:

- The RESET procedure can interact with all EPs.
- The IU RELEASE procedure can interact with all EPs except the RESET procedure.

3.2 Abbreviations

AAL2	ATM Adaptation Layer type 2
AS	Access Stratum
ASN.1	Abstract Syntax Notation One
ATM	Asynchronous Transfer Mode
CN	Core Network
CRNC	Controlling RNC
CS	Circuit Switched
DRNC	Drift RNC
DRNS	Drift RNS
EP	Elementary Procedure
MSC	Mobile services Switching Center
NAS	Non Access Stratum
PDU	Protocol Data Unit
PS	Packet Switched
QoS	Quality of Service
RAB	Radio Access Bearer
RNC	Radio Network Controller
RNS	Radio Network Subsystem
RANAP	Radio Access Network Application Part
SCCP	Signalling Connection Control Part
SGSN	Serving GPRS Support Node
SRNC	Serving RNC
SRNS	Serving RNS
UE	User Equipment
UTRAN	UMTS Terrestrial Radio Access Network

4 General

[Editor's note: This chapter should describe requirements on RANAP forward/backward compatibility, error handling principles, message coding principles etc.]

5 RANAP Services

[Editor's note: This chapter should describe services of RANAP protocol.]

[Editor's note: It has been agreed that the editor will provide text for this section.]

The RANAP offers the following services:

6 Services expected from signalling transport

[Editor's note: This chapter should describe expected services from signalling transport.]

[Editor's note: It has been agreed that the editor will provide text for this section.]

7 Functions of RANAP

Note. This section needs to be checked after the Iu functions have been specified.

RANAP protocol has the following functions:

- Relocating Serving RNC. This function enables to change the serving RNC functionality as well as the related Iu resources (RAB(s) and Signalling connection) from one RNC to another.
- Overall RAB management. This function is responsible for setting up, modifying and releasing RABs.
- Queuing the setup of RAB. The purpose of this function is to allow placing some requested RABs into a queue, and indicate the peer entity about the queuing.
- Requesting RAB release. While the overall RAB management is a function of the CN, the UTRAN has the capability to request the release of RAB.
- Release of all Iu Resources. This function is used to explicitly release all resources related to one UE from the corresponding Iu connection.
- Requesting the release of all Iu Resources. While the Iu release is managed from the CN, the UTRAN has the capability to request the release of all Iu resources from the corresponding Iu connection.
- Controlling Overload in the Iu Interface. This function allows adjusting the load in the Iu interface.
- Resetting the Iu. This function is used for resetting an Iu interface.
- Sending the UE Common Id (permanent NAS UE identity) to the RNC. This function makes the RNC aware of the UE's common Id.
- Paging the user. This function provides the CN for capability to page the UE.
- Controlling the tracing of the UE activity. This function allows setting the trace mode for a given UE.
- Transport of NAS information between UE and CN. This function has three sub-classes.
 - Transport of the initial NAS signalling message from the UE to CN. This function transfers transparently the NAS information. As a consequence also the Iu signalling connection is set up.
 - Transport of NAS signalling messages between UE and CN, This function transfers transparently the NAS signalling messages on the existing Iu signalling connection.
 - Transport of NAS information to be broadcasted to UEs. This function allows setting the NAS information to be broadcasted to the UEs from the CN.
- Controlling the security mode in the UTRAN. This function is used to send the security keys (ciphering and integrity check) to the UTRAN, and setting the operation mode for security functions.
- Controlling Location Reporting. This function allows the CN to set the mode in which the UTRAN reports the location of the UE
- Location Reporting. This function is used for transferring the actual location information from RNC to the CN.

- Reporting general error situations. This function allows reporting of general error situations, for which function specific error messages have not been defined.

These functions are implemented by one or several RANAP elementary procedures described in the following section.

8 RANAP procedures

[Editor's note: The procedure descriptions starting in section 8.2 have been rearranged. This order is editor's proposal.]

8.1 Elementary Procedures

In the following tables, all EPs are divided into Class 1, Class 2 and Class 3 EPs:

Class 1

Elementary Procedure	Message	Successful Outcome		Unsuccessful Outcome	
		Response message	EP	Response message	Timer
Relocation preparation	RELOCATION REQUIRED	RELOCATION COMMAND		RELOCATION PREPARATION FAILURE	
Relocation resource allocation	RELOCATION REQUEST	RELOCATION REQUEST ACKNOWLEDGE		RELOCATION FAILURE	
Relocation cancel	RELOCATION CANCEL	RELOCATION CANCEL ACKNOWLEDGE			
Rab release request	RAB RELEASE REQUEST		RAB ASSIGNMENT		
Iu release request	IU RELEASE REQUEST		IU RELEASE		
Iu release	IU RELEASE COMMAND	IU RELEASE COMPLETE			
Reset	RESET	RESET ACKNOWLEDGE			
Cipher mode control	CIPHER MODE COMMAND	CIPHER MODE COMPLETE		CIPHER MODE REJECT	
Cn information broadcast	CN INFORMATION BROADCAST REQUEST	CN INFORMATION BROADCAST CONFIRM		CN INFORMATION BROADCAST REJECT	

Class 2

Elementary Procedure	Message
Relocation detect	RELOCATION DETECT
Relocation complete	RELOCATION COMPLETE
Overload	OVERLOAD
Common ID	COMMON ID
Paging	PAGING
CN invoke trace	CN INVOKE TRACE
Direct transfer	DIRECT TRANSFER
Initial UE message	INITIAL UE MESSAGE
Location reporting control	LOCATION REPORTING CONTROL
Location report	LOCATION REPORT
Error indication	ERROR INDICATION

Class 3

Elementary Procedure	Message	Outcome
RAB Assignment	RAB ASSIGNMENT REQUEST	RAB ASSIGNMENT RESPONSE x N (N>=1)

8.3 Radio Access Bearer Assignment

8.3.1 Normal operation

This procedure is used to modify or release an already established RAB or to establish a new RAB for a given UE. The procedure is connection oriented. The signalling flow for the RAB Assignment procedure is shown in [Figure 1](#).

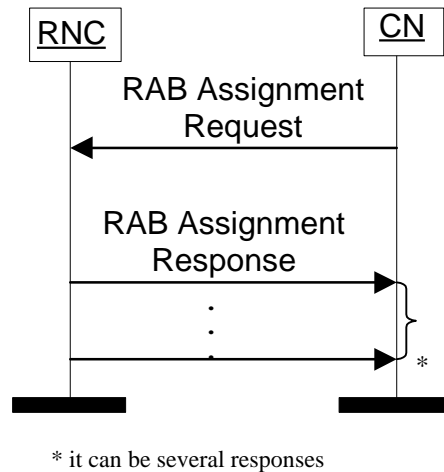

Figure 1. RAB Assignment procedure.

The CN initiates the procedure by sending a RAB ASSIGNMENT REQUEST message. When sending the RAB ASSIGNMENT REQUEST, the CN starts the $T_{RABAssgt}$ timer .

The message contains the information required by the UTRAN to build the new RAB configuration. CN can request UTRAN to:

- establish
- modify
- release

one or several RABs with one RAB ASSIGNMENT REQUEST message.

The RAB ASSIGNMENT REQUEST message contains the following information:

- list of RABs to establish with their bearer characteristics
- list of RABs to modify with their bearer characteristics
- list of RABs to release

Upon reception of the RAB ASSIGNMENT REQUEST message UTRAN shall execute the requested RAB configuration. UTRAN shall report to CN the outcome of the request by sending RAB ASSIGNMENT RESPONSE message(s).

UTRAN can report to CN for one or several RABs, which are:

- successfully established with their respective bearer characteristics (note FFS)
- successfully modified RABs with their respective bearer characteristics (note FFS)
- released
- failed to establish or modify or release
- queued

in one RAB ASSIGNMENT RESPONSE message.

If none of the RABs have been queued, the CN shall stop timer $T_{RABAssgt}$ and the RAB Assignment procedure terminates. In that case, the procedure is also terminated in UTRAN.

Note FFS: The RAB parameters in the bearer characteristics are included in the RAB ASSIGNMENT RESPONSE message only if they are different than requested in the RAB ASSIGNMENT REQUEST message.

UTRAN shall report the outcome of a specific RAB configuration change only after the transport network control plane signalling, which is needed for this configuration establishment or modification, has been executed.

When the request to establish or modify one or several RABs is queued, UTRAN shall start the timer T_{QUEUING} . This timer specifies the maximum time for queuing of the request of establishment or modification. The same timer T_{QUEUING} is supervising all RABs being queued.

For each RABs that are queued the following outcomes are possible:

- successfully established or modified
- failed to establish or modify
- failed due to expiry of the timer T_{QUEUING}

In the first RAB Assignment response message the RNC shall report about all RABs referenced in the RAB ASSIGNMENT REQUEST. Except in the case of T_{QUEUING} expiry, UTRAN shall report the outcome of the queuing for every RAB individually or for several RABs in the RAB ASSIGNMENT RESPONSE message(s). This is left to implementation. UTRAN shall stop T_{QUEUING} when all RABs have been either successfully established or modified or failed to establish or modify. The RAB Assignment procedure is then terminated both in CN and UTRAN.

[Contributor's Note: Following two bullet points can be removed and the information can be moved to message contents chapter as proper parameters.]

To ensure the necessary load sharing on the Iu-PS interface,

- *When the CN sends RAB ASSIGNMENT REQUEST for all Radio Access Bearers (associated with PDP contexts) of an UE, the CN specifies the IP address of the packet processing function allocated to this / each of these PDP context(s) in the CN.*
- *In the response to the CN request, i.e. in RAB ASSIGNMENT RESPONSE, the RNC specifies the IP address of the packet processing function allocated to this / each of these Radio Access Bearer(s) in the RNC.*

When CN receives the response that one or several RABs are queued, CN expects UTRAN to provide the outcome of the queuing function for each RAB before expiry of the T_{RABAssgt} timer. Otherwise, CN considers the RAB Assignment procedure terminated.

In the case the timer T_{QUEUING} expires, the RAB ASSIGNMENT procedure terminates in UTRAN for all queued RABs, and UTRAN shall respond for all of them in one RAB ASSIGNMENT RESPONSE message. The RAB Assignment procedure is also terminated in CN.

8.4 RAB Release Request

This procedure is used to request a release of one or several radio access bearers from UTRAN side. Procedure is initiated by RNC generating a RAB RELEASE REQUEST message towards the CN. The procedure is connection oriented.

This message indicates the list of RABs requested to be released and cause value for each release request. On receipt of a RAB RELEASE REQUEST the CN shall initiate RAB Assignment procedure requesting indicated RABs to be released.

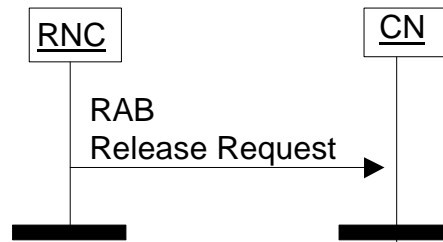

Figure 22. RAB Release Request procedure.

8.5 Iu Release Request

If the release of the radio bearers assigned to a particular UE is required because of a UTRAN generated reason (e.g. "O and M intervention", "equipment failure", "RAB pre-empted") then, the RNS controlling the Iu connection(s) of that particular UE shall generate an Iu RELEASE REQUEST message towards the CN. If it exists two Iu connections for that particular UE, then an Iu RELEASE REQUEST message shall be sent to CN domain. Iu Release Request is a connection oriented procedure.

If the contact with the UE is lost then an Iu RELEASE REQUEST message shall be sent to the CN node(s) having an Iu connection with the RNS for that particular UE.

The Iu RELEASE REQUEST message shall include a Cause Information Element, indicating the reason for the release. The signalling flow for Iu Release procedure due to UTRAN generated reasons is shown in [Figure 3](#)
[Figure 3](#):



Figure 33. Iu Release Request procedure.

8.6 Iu Release

Iu Release procedure is used by CN to release the Iu connection and all UTRAN resources related only to the Iu connection to be released. Messages belonging to this procedure are transmitted utilising the connection oriented mode of the signalling bearer.

The Iu Release procedure can be initiated for the following reasons:

- Completion of transaction between UE and CN.
- UTRAN generated reasons, i.e. reception of IU RELEASE REQUEST.
- Completion of successful relocation of SRNS.

Procedure is initiated by the CN by sending message IU RELEASE COMMAND to UTRAN.

After the Iu RELEASE COMMAND has been sent, the CN shall not send further RANAP connection oriented messages on this particular connection, except Iu RELEASE COMMAND.

The Iu RELEASE COMMAND message shall include a Cause Information Element, indicating the reason for the release.

When the RNS receives the Iu RELEASE COMMAND:

- 1) The clearing of the UTRAN resources is initiated. However, the UTRAN shall not clear resources related to other Iu signalling connections the UE might have.
- 2) The RNC returns an Iu RELEASE COMPLETE message to the CN and takes action to return any assigned user plane resources to idle. (The RNC does not need to wait for the release of UTRAN resources to be completed before returning the Iu RELEASE COMPLETE message.)

The signalling flow for Iu Release procedure is shown in [Figure 4](#)~~Figure 4~~[Figure 4](#):

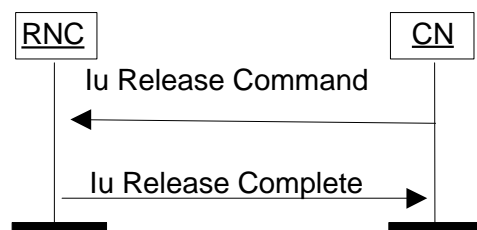

Figure 444. Iu Release procedure.

8.2 Relocation

8.2.1 General

Note 1: The impact of handover from GPRS to UMTS on Relocation procedure shall be studied.

Note 2: The reason for initiating the procedure has to be included (an air interface handover or SRNS relocation).

Relocation is used to relocate the serving RNS functionality from one RNS to an other. Procedure may or must not involve change of the radio resources assigned for the corresponding UE. This procedure can be used within one UTRAN if the Iur interface can not (or is not desired to) be used for active set management, between two UTRANs or at UTRAN side in handovers between two Radio Access systems (e.g. UMTS to GSM).

Relocation is carried over Iu interface, by the RANAP protocol.

All RANAP messages concerned with relocation are sent using the connection oriented mode of the signalling ~~connection bearer~~.

8.2.2 Relocation Preparation

8.2.2.1 Successful operation

Procedure is initiated by the Serving RNC by sending a RELOCATION REQUIRED message to active CN nodes. Timer T(RELOCATION COMMAND) is started, upon transmitting the message. RELOCATION REQUIRED message allows a RNC to request that a relocation is to be carried out for a particular UE, having signalling connection via the serving RNC.

The cause of the relocation preparation initiation is indicated to the CN. It is used by the CN to proceed the relocation preparation execution appropriately e.g. considering switching execution timing.

As a response to the RELOCATION REQUIRED message the CN sends RELOCATION COMMAND to the source RNC.

Upon reception of RELOCATION COMMAND belonging to ongoing procedure the RNC stops the timer T(RELOCATION COMMAND). Depending on the cause of the relocation preparation initiation, hard handover or SRNS relocation, the source RNC either triggers the handover procedure in the air interface or commits the execution of the relocation in the target RNS, respectively.

The signalling flow between the source RNC and the CN is shown in [Figure 5](#)[Figure 5](#)[Figure 1](#).

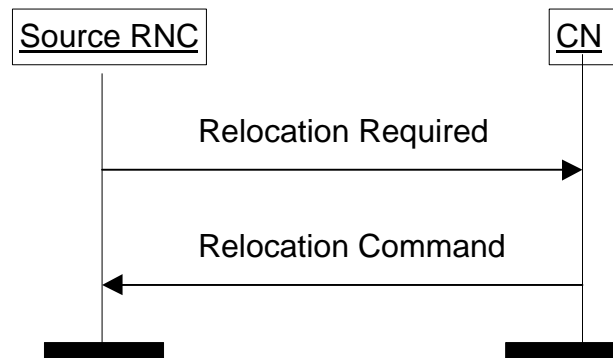

Figure 551. Relocation Preparation procedure between source RNC and CN.

8.2.2.2 Unsuccessful operation

If a failure occurs during the Relocation preparation procedure in the CN, the CN sends RELOCATION PREPARATION FAILURE message to the source RNC.

The signalling flow for this case is shown in [Figure 6](#)[Figure 6](#)[Figure 2](#).

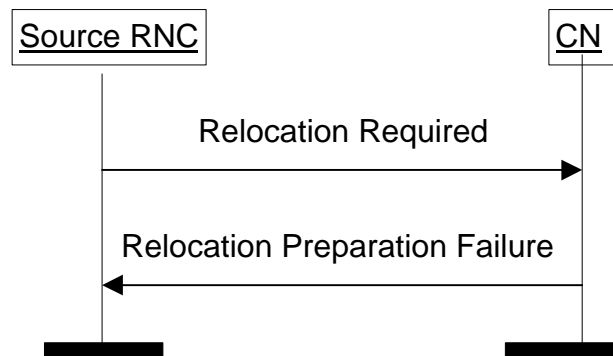

Figure 662. Relocation preparation failure.

8.2.2.3 Relocation co-ordination in source RNC

Relocation co-ordination shall be executed by source RNC when serving RNS relocation is to be done for an UE having multiple Iu signalling connections. If multiple Iu signalling connections are involved following co-ordination of relocation shall be ensured by source RNC.

When RNC initiates relocation of serving RNC functionality for an UE, source RNC shall initiate Relocation Preparation procedure on all Iu signalling connections existing for the UE.

Source RNC has to indicate in each RELOCATION REQUIRED message the amount of Iu signalling connections between source RNC and CN involved into the relocation of the serving RNC.

Source RNC shall proceed in execution of the relocation of SRNC only once Relocation Preparation procedure is successfully terminated on all Iu signalling connections existing for the UE.

If source RNC receives RELOCATION PREPARATION FAILURE from CN, source RNC has to cancel all other pending or successfully terminated Relocation Preparation procedures related to the same relocation of serving RNC by initialising a Relocation Cancel procedure on the corresponding Iu signalling connections.

If source RNC decides to cancel Relocation Preparation procedure due to other reasons than reception of RELOCATION PREPARATION FAILURE, the Relocation Cancel procedure has to be initiated on all Iu signalling connection existing for the UE.

8.2.3 Relocation resource allocation

8.2.3.1 Successful operation

The CN node sends a RELOCATION REQUEST message to the target RNC (selected by the source RNC and indicated in the RELOCATION REQUIRED message). This message contains details of the resource(s) required like bearer identifier and binding ID of each bearer to be established to the new Iu interface.

On receipt of this message the target RNC shall check availability of requested resources.

If all necessary resource(s) including the User plane setup are successfully allocated the target RNC sends back to the CN a RELOCATION REQUEST ACKNOWLEDGE message. The RELOCATION REQUEST ACKNOWLEDGE message sent by the target RNC may optionally contain a transparent container, which is transferred by the CN node to the source RNC using the RANAP message RELOCATION COMMAND.

~~To ensure the necessary load sharing on the Iu-PS interface,~~

~~—When the CN sends RELOCATION REQUEST for all Radio Access Bearers (associated with PDP contexts) of an UE, the CN specifies the IP address of the packet processing function allocated to this / each of these PDP context(s) in the CN.~~

~~—In the response to the CN request, i.e. in RELOCATION REQUEST ACKNOWLEDGE, the RNC specifies the IP address of the packet processing function allocated to this / each of these Radio Access Bearer(s) in the RNC.~~

~~Figure 7~~ ~~Figure 7~~ ~~Figure 3~~ shows the signalling flow for Relocation resource allocation.

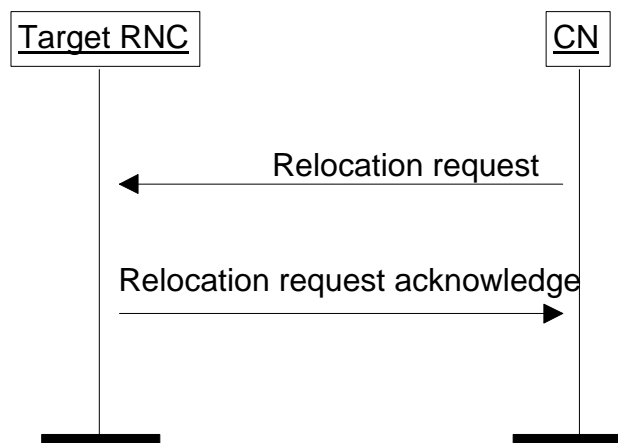

~~Figure 7~~ ~~7~~ ~~3~~. Resource allocation for relocation.

8.2.3.2 Unsuccessful operation

If a failure occurs during the Relocation resource allocation procedure in the target RNC, the target RNC sends RELOCATION FAILURE message to the CN.

The signalling flow for this case is shown in ~~Figure 8~~ ~~Figure 8~~ ~~Figure 4~~.

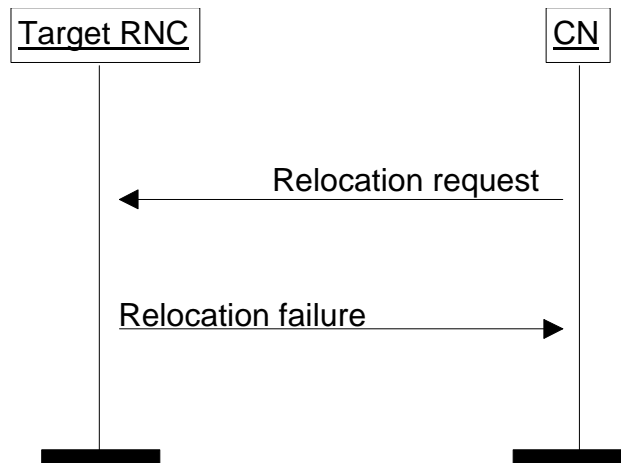

Figure 884. Relocation resource allocation failure.

8.2.3.3 Relocation co-ordination in target RNC

Relocation co-ordination shall be executed by target RNC when a received RELOCATION REQUEST message indicates that more than one Iu signalling connection is involved.

Target RNC should handle Relocation Resource Allocation procedures in general independently of each other. However the information which may depend on the contents of all the expected RELOCATION REQUEST messages and which is to be sent in the transparent field to the source RNC (e.g. information of new radio resources) shall be sent only after all expected RELOCATION REQUEST messages are received and analysed.

Target RNC has to ensure that there is no conflicting information in target RNC to source RNC Transparent fields in RELOCATION REQUEST ACKNOWLEDGE messages transmitted via different Iu signalling connections and related to the same relocation.

The selection of signalling connection utilised for the different kind of transparent information in RELOCATION REQUEST ACKNOWLEDGE message is not dependent on the signalling connection via which transparent information was received in RELOCATION REQUEST message.

8.2.4 Relocation Detect

When the relocation execution trigger is received, the target RNC shall send a RELOCATION DETECT message to the active CN nodes and start to act as an SRNC.

The signalling flow for Relocation detect procedure is shown in [Figure 9](#).

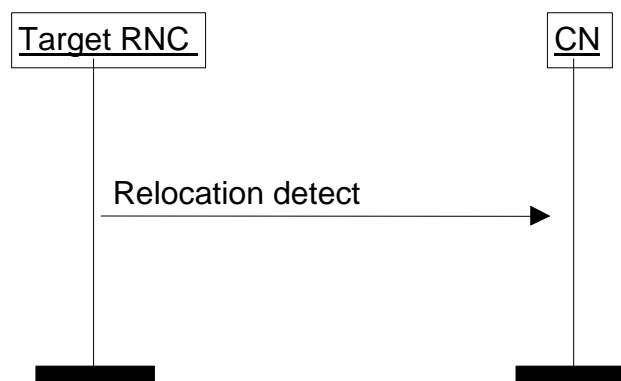

Figure 995. Relocation Detect procedure.

8.2.5 Relocation Complete

When the UE is successfully in communication with the target RNC, i.e. the new SRNC-ID + SRNTI are successfully exchanged with the UE, then the target RNC shall send a RELOCATION COMPLETE message to the CN and terminate the procedure.

The signalling flow for Relocation complete procedure is illustrated in [Figure 10](#)~~Figure 10~~[Figure 6](#).

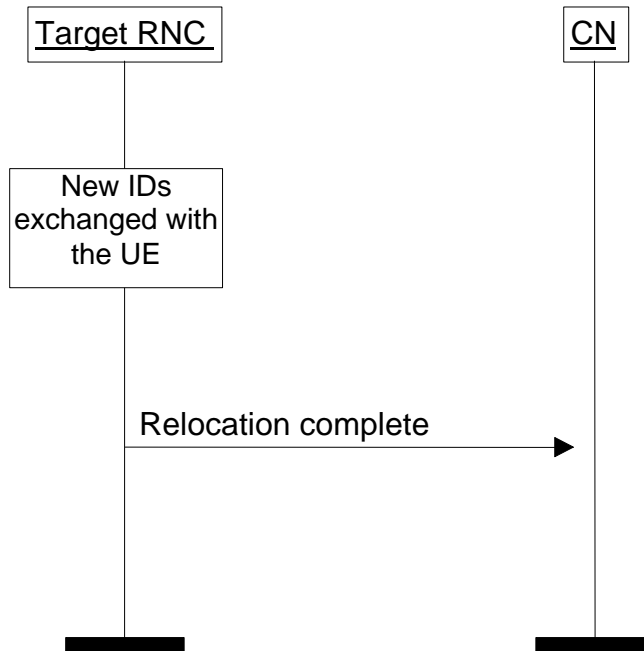

Figure ~~10~~[10](#)~~6~~[6](#). Relocation Complete procedure.

The CN elements shall release all resources associated to the Source RNS.

8.2.6 Relocation Cancel

When the source RNC has decided to cancel the relocation, it sends RELOCATION CANCEL message to the CN. If the CN receives RELOCATION CANCEL message, the CN terminates the ongoing Relocation preparation procedure (if any) and sends RELOCATION CANCEL ACKNOWLEDGE message to the source RNC.

The signalling flow for Relocation Cancel procedure is shown in [Figure 11](#)~~Figure 11~~[Figure 7](#).

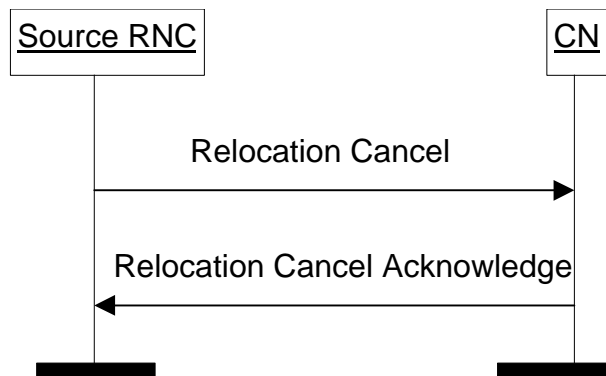

Figure ~~11~~[11](#)~~7~~[7](#). Relocation Cancel procedure.

8.10 Paging

PAGING messages for all UEs shall be sent as a connectionless message. These will include some information to allow derivation of the paging population number, the IMSI of the user to be used as the Common Id of the user in the RNC, the Id of the User to be used in the paging channel (e.g. TMSI); they may also include information on the subsequent transaction related to the paging. A corresponding radio interface paging message transmitted over the radio interface at the appropriate time. The issue of storing the PAGING message for future paging repetition is FFS.

It should be noted that each PAGING message on the CN-UTRAN interface relates to only one UE and therefore the UTRAN has to pack the pages into the relevant radio interface paging message.

The CN node sending the PAGING message shall set the CN domain indicator according to its own type i.e. CS domain or PS domain.

Note. Once the domain distribution is clarified with SA2 the Paging indicator may need to be modified.

A single PAGING message across the CN to UTRAN interface contains information on the area in which the page shall be broadcast. This is indicated with Paging Area ID (content FFS, e.g. LA or RA).

The signalling flow of the paging procedure is illustrated in [Figure 12](#) ~~Figure 12~~.



Figure ~~12~~16. Paging procedure.

8.9 Common Id

This procedure is needed, if the MM concept will require the UTRAN to send a page message on the existing RRC connection. This procedure is connection oriented.

The purpose of the Common Id procedure is to allow the RNC to create a reference between the permanent NAS UE Identity of a user and the RRC connection of that user. This is achieved by sending the permanent NAS UE Identity of a verified user from the CN to the RNC. The RNC is then able to check whether there is already signalling bearer to the UE when a CN starts connection establishment by sending Paging message. The signaling bearer can be already used by an other CN, and if this is the case, the RNC uses it to send the Paging message to the UE.

The CN sends a COMMON ID message after it has ensured the identity of UE. The message contains the permanent NAS UE Identity of the user. The RNC associates the permanent identity to the RRC Connection of that user and saves it for the duration of the RRC connection. The signalling flow Common Id procedure is shown in [Figure 13](#) ~~Figure 13~~.



Figure ~~13~~17. Common Id procedure.

8.11 CN Invoke Trace

The purpose of the CN Invoke Trace procedure is to inform the receiving entity that it should begin producing a trace record on this particular transaction.

The trace is invoked by the CN sending a CN INVOKE TRACE message to the UTRAN.

The events and parameters to be recorded are indicated in the “Trace type” information element.

The element “OMCId”, if present, indicates the OMC to which the record is destined.

The CN may allocate and include an “CN transaction reference” (typically a call reference) into the CN INVOKE TRACE message. The transaction reference is contained in the information element “TransactionId”.

The message includes a trace reference which is allocated by the entity which triggered the trace.

The element “TriggerId”, if present, indicates the entity which triggered the trace.

The trace reference, triggerId and transactionId Information Elements are used to tag the trace record to allow simpler construction of the total record by the entity which combines trace records.

The message is sent as a connection oriented message on the connection on which a trace is required.

The signalling flow of the CN Invoke Trace procedure is shown in [Figure 14](#)~~Figure 14~~~~Figure 14~~.

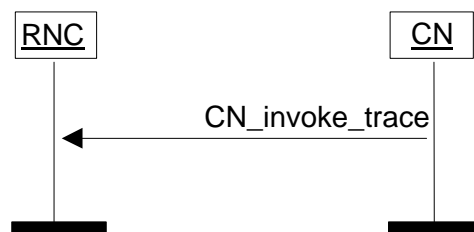

Figure ~~14~~~~14~~~~14~~. CN Invoke Trace procedure.

8.12 Cipher Mode Control

8.12.1 Successful operation

The cipher mode control procedure allows the CN to pass cipher mode information to the UTRAN to select and load the user data and signaling encryption device with the appropriate key.

This is achieved by sending the UTRAN a CIPHER MODE COMMAND message. Receipt of the message at the UTRAN will trigger the execution of the corresponding radio interface procedure and, if applicable, invoke the encryption device and start stream ciphering.

In the CIPHER MODE COMMAND the CN specifies which of the ciphering algorithms may be used by the UTRAN. The UTRAN then selects internally an appropriate algorithm, taking into account the UE ciphering capabilities. The UTRAN can deduce from the UE capability information of the supported algorithms. The CIPHER MODE COMPLETE message returned to the CN indicates the chosen ciphering algorithm. The set of permitted ciphering algorithms specified in the CIPHER MODE COMMAND shall remain applicable for subsequent Assignments and Intra-UTRAN Handovers.

The CIPHER MODE COMMAND and CIPHER MODE COMPLETE messages utilise the connection oriented mode of the signalling bearer.

When the radio interface is operating according to the CIPHER MODE COMMAND, RNC shall send the CIPHER MODE COMPLETE message to the CN.

The handling of ciphering keys from two CN entities is FFS.

The signalling flow of the successful Cipher mode control procedure is shown in ~~Figure 15~~ ~~Figure 15~~ ~~Figure 15~~.

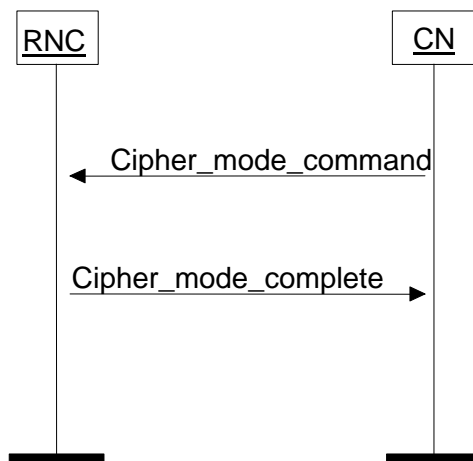

Figure ~~15~~ ~~15~~ ~~15~~. Cipher Mode Control procedure, successful case.

8.12.2 Unsuccessful operation

If the UTRAN or the UE is unable to support the ciphering algorithm specified in the CIPHER MODE COMMAND message then it shall return a CIPHER MODE REJECT message with Cause value “Ciphering algorithm not supported”. A CIPHER MODE REJECT message shall also be returned if the CN requests a change of ciphering algorithm when ciphering is already active.

The signalling flow of the Cipher mode control procedure in abnormal conditions is shown in ~~Figure 16~~ ~~Figure 16~~ ~~Figure 16~~.

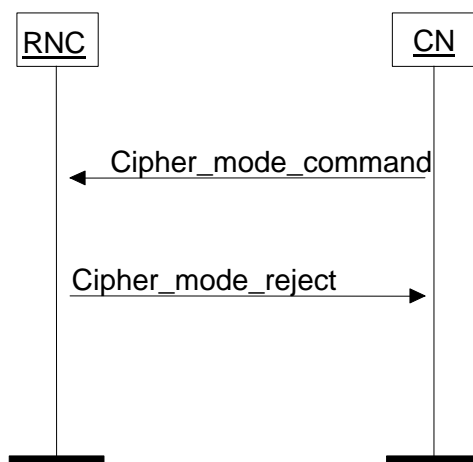

Figure ~~16~~ ~~16~~ ~~16~~. Cipher Mode Control procedure, unsuccessful case.

8.16 Location Reporting Control

Note. This procedure needs to be aligned with the GSM location services.

8.16.1 Normal operation

The LOCATION REPORTING CONTROL message is issued from the CN to the RNC. It is used to initiate, modify or stop location reporting from RNC to CN, while the UE, whose location is to be reported has its connection with the CN. Each ongoing Location reporting is assigned a reporting number, which will be used in Location Report messages triggered by the respective Location Reporting Control procedure. The procedure is connection oriented.

Note. The identification of different location reports is FFS.

The signalling flow for Location Request procedure is shown in [Figure 17](#)~~Figure 17~~[Figure 17](#).

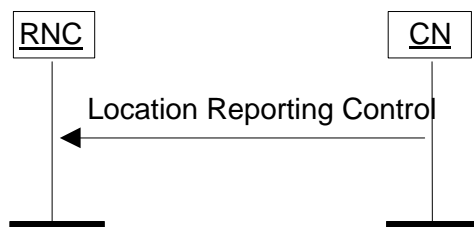

Figure [17](#)~~17~~[17](#). Location Reporting Control procedure.

8.16.2 Abnormal conditions

8.16.2.1 Abnormal conditions in RNC

If RNC receives a Location Reporting Control message indicating a change in measurement parameters which are in contradiction to existing parameters RNC shall ignore the existing parameters in RNC and assume the parameters given in the new message as correct. *Note. The definition of existing parameters is FFS.*

8.17 Location Report

8.17.1 Successful operation

The LOCATION REPORT message is issued from the RNC to the CN. It is used to provide the UE location information to the CN. This may be used as a response for the LOCATION REPORTING CONTROL message. Also, when a user enters or leaves a classified area set by O&M, e.g. disaster area, a LOCATION REPORT message will be sent to the CN. Cause information is included in the message. Other triggers of this message are FFS. The procedure is connection oriented.

The signalling flow for Location Report procedure is shown in [Figure 18](#)~~Figure 18~~[Figure 18](#).

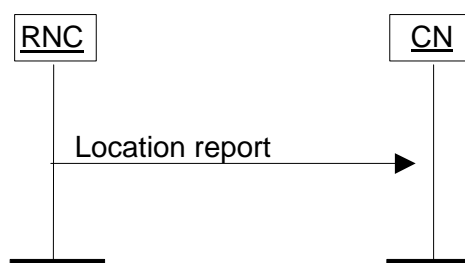

Figure [18](#)~~18~~[18](#). Location Report procedure.

8.17.2 Unsuccessful operation

If the RNC can not deliver the location information as requested, RNC shall indicate UE location to be "Undetermined". A cause value shall be added to indicate the reason for the undetermined location.

8.17.3 Abnormal conditions

8.17.3.1 Abnormal conditions in CN

If CN receives a Location Report message reporting Location that was not requested by CN, CN should stop the indicated location reporting by utilising Location Reporting Control procedure. (FFS).

8.15 Initial UE Message

When the Iu signalling connection establishment is performed by the RNC, the radio interface initial layer 3 message received from the UE is proceeded. The procedure is connection oriented.

The RNC shall analyze the protocol discriminator of the message and if entire radio interface initial layer 3 message (e.g. CM SERVICE REQUEST, LOCATION UPDATE REQUEST, PAGING RESPONSE, IMUI DETACH) is also passed to the CN, using an INITIAL UE MESSAGE. The RNC does not analyze the contents of the initial layer 3 message, it may be added the other information (e.g. location information)..

The signalling flow for Initial UE Message procedure is shown in [Figure 19](#)~~Figure 19~~~~Figure 19~~.

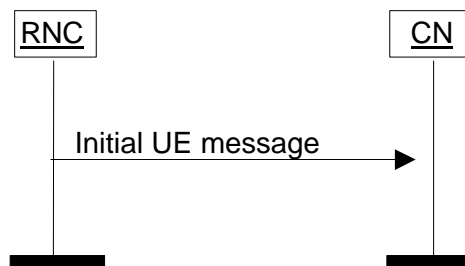

Figure 19~~19~~~~19~~. Initial UE Message procedure.

8.14 Direct Transfer

The Direct Transfer procedure is used to carry UE – CN signaling messages over the Iu Interface. The UE – CN signalling messages are not interpreted by the UTRAN, and their content (e.g. MM or CC message) is outside the scope of this specification. The UE – CN signalling messages are transported as a parameter in the Direct Transfer messages. The procedure is connection oriented.

When the CN has message that has to be sent to the UE (e.g. a CC or MM message) it will send DIRECT TRANSFER to the RNC including the CN to UE message as a parameter. The signalling flow for the CN originated Direct transfer procedure is shown in [Figure 20](#)~~Figure 20~~~~Figure 20~~.



Figure 20~~20~~~~20~~. Direct Transfer, CN originated.

When the RNC has received a message from the UE that has to be sent to the CN without interpretation (e.g. a CC or MM message in response to the previously sent CC or MM message from the CN) it will send DIRECT TRANSFER to the CN and including the UE to CN message as a parameter. The signalling flow for the UTRAN originated Direct transfer procedure is shown in [Figure 21](#)~~Figure 21~~~~Figure 21~~.



Figure 21.21. Direct Transfer, RNC originated.

8.13 CN Information Broadcast

A functionality of the (UT)RAN is to broadcast repetitively to all users [in idle mode] system information as provided by the core network. A core network element sets or modifies the CN system information by sending a connectionless CN INFORMATION BROADCAST REQUEST message which indicates:

- The information pieces to be broadcast, as a number of bit strings. The internal structure of these bit strings is not known or analysed by the RAN, and is specified as part of the CN-UE protocols.
- With each bit string, a geographical area where to broadcast it.
- With each bit string, some categorisation parameters to be used by the RAN to determine how to schedule the repetition cycle.

If the UTRAN can broadcast the information as requested, a CN INFORMATION BROADCAST CONFIRM message is returned to the CN.

If the UTRAN can not broadcast the information as requested, a CN INFORMATION BROADCAST REJECT message is returned to the CN.

Each information piece is broadcast in the intersection between the indicated geographical area and the area under control by the receiving RNC. It is broadcast until explicitly changed or a reset occurs. In case the ending of the broadcasting hasn't been indicated when setting the broadcasting, an empty bit string will be used to turn off the broadcasting. A CN element will run this procedure typically after each reset, and whenever the information needs to be changed.

Between a reset and the first reception of this message, what is broadcast is FFS. However, great care shall be taken to ensure that UE's do not reselect another PLMN and cause e.g. a surge of location updating on that other PLMN.

8.7 Overload Control

8.7.1 General

These procedures are defined to give some degree of flow control. At the UTRAN processor overload and overload in the capability to send signalling messages to the UE are catered for, and at the CN processor overload is catered for. Overload procedure is connectionless.

8.7.2 Philosophy

The philosophy used is to stem the traffic at source with known effect on the service. The algorithm used is:

- On receipt of the first OVERLOAD message or signaling point congested information, the traffic is reduced by one step. It is also possible optionally to indicate the number of steps to reduce the traffic. At the same time, timers T(igOC)(T(igOR)) and T(inTC)(T(inTR)) are started. During T(igOC)(T(igOR))

all received overload messages or signaling point congested information are ignored in order not to reduce the traffic too rapidly. Reception of an OVERLOAD message or signaling point congested information after expiry of $T_{(igOC)}(T_{(igOR)})$ but still during $T_{(inTC)}(T_{(inTR)})$, will decrease the traffic load by one more step, and restart $T_{(igOC)}(T_{(igOR)})$ and $T_{(inTC)}(T_{(inTR)})$.

- This step by step reduction of traffic is continued until maximum reduction is obtained by arriving at the last step. If $T_{(inTC)}(T_{(inTR)})$ expires (i.e. no OVERLOAD message or signaling point congested information is received during $T_{(inTC)}(T_{(inTR)})$) the traffic will be increased by one step and $T_{(inTC)}(T_{(inTR)})$ will be started, unless full load has been resumed.

NOTE: Timers $T_{(igOC)}$ and $T_{(inTC)}$ are running in the CN whilst Timers $T_{(igOR)}$ and $T_{(inTR)}$ are running in the UTRAN.

- The number of steps and the method of reducing the load is considered to be an implementation specific function.

There may be other traffic control mechanisms from O and M activities occurring simultaneously.

8.7.3 Overload at the CN

The CN can indicate to the RNC that it is in a congested state by sending an OVERLOAD message. This is sent as a connectionless global message.

At the UTRAN receipt of this message causes the reduction of traffic to the CN node sending the message.

The signalling flow for Overload at the CN is shown in [Figure 22](#)~~Figure 22~~[Figure 15](#).

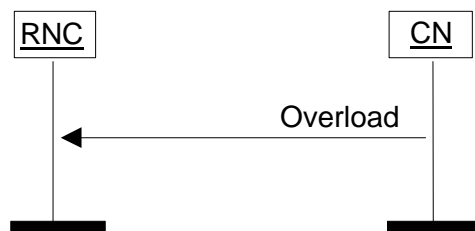

Figure ~~22~~[22](#)~~15~~[15](#). Overload at the CN.

8.7.4 Overload at the UTRAN

If the UTRAN is not capable to send signalling messages to the UE due to overloaded resources then the UTRAN sends an OVERLOAD message to the CN.

The signalling flow for Overload at the UTRAN is shown in [Figure 23](#)~~Figure 23~~[Figure 16](#).



Figure ~~23~~[23](#)~~16~~[16](#). Overload at the UTRAN.

8.8 Reset

8.8.1 General

The purpose of the reset procedure is to initialise the UTRAN and CN in the event of a failure. The procedure is a global procedure applying to a whole RNC (instead of a particular UE), and therefore all messages relating to the reset procedure are sent as global messages using the connectionless mode of the signalling ~~connection bearer~~.

If only a limited part of the CN or UTRAN has suffered a failure then Radio Access Bearer Assignment Request procedures (indicating bearer release) can be used to clear only the affected Radio Access Bearers.

8.8.2 Reset at the UTRAN

In the event of a failure at the UTRAN which has resulted in the loss of transaction reference information, a RESET message is sent to the CN. This message is used by the CN to release affected Radio Access Bearers and erase all affected references.

After a guard period of T(RatR) seconds a RESET ACKNOWLEDGE message is returned to the UTRAN indicating that all references have been cleared.

The signalling flow for Reset at the UTRAN is shown in ~~Figure 24~~ ~~Figure 24~~ ~~Figure 17~~.

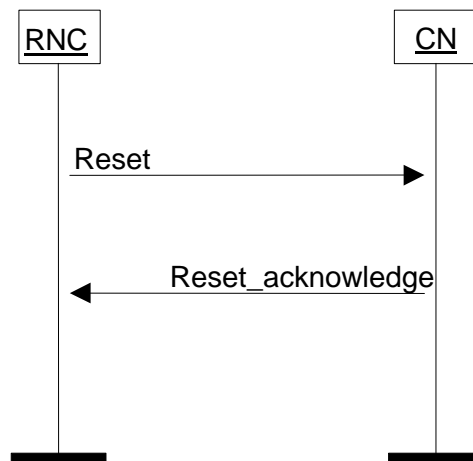

Figure ~~24~~ ~~24~~ ~~17~~. Reset at the UTRAN.

8.8.3 Reset at the CN

In the event of a failure at the CN which has resulted in the loss of transaction reference information, a RESET message is sent to the RNC. This message is used by the UTRAN to release affected Radio Access Bearers and erase all affected references.

After a guard period of T(RatC) seconds a RESET ACKNOWLEDGE message is returned to the CN, indicating that all UEs which were involved in a call are no longer transmitting and that all references at the UTRAN have been cleared.

~~Figure 25~~ ~~Figure 25~~ ~~Figure 18~~ shows the signalling flow for Reset at the CN.

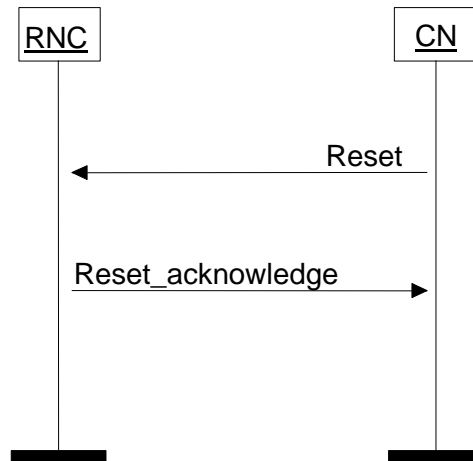

Figure ~~25.25.18~~ 18. Reset at the CN.

8.8.4 Abnormal Conditions

8.8.4.1 Abnormal Condition at the UTRAN

If the RNC sends a RESET message to the CN and receives no RESET ACKNOWLEDGE message within a period $T(\text{RafC})$ then it shall repeat the entire reset procedure. The sending of the RESET message is repeated a maximum of “n” times where n is an operator matter. After the n-th unsuccessful repetition the procedure is stopped and the maintenance system is informed.

8.8.4.2 Abnormal Condition at the CN

If the CN sends a RESET message to the RNC and receives no RESET ACKNOWLEDGE message within a period $T(\text{RafR})$ then it shall repeat the entire reset procedure. The sending of the RESET message is repeated a maximum of “n” times where n is an operator matter. After the n-th unsuccessful repetition the procedure is stopped and the maintenance system is informed.

8.8.4.3 Crossing of Reset messages

When an entity has sent a RESET message and is waiting for a RESET ACKNOWLEDGE message, but receives a RESET message from the peer entity, the sending entity stops timer $T(\text{RatC}$ or $\text{RatR})$ and sends a RESET ACKNOWLEDGE message to the peer entity.

8.18 Error Indication

8.18.1 General

The Error Indication procedure is used to carry error messages over the Iu Interface. The procedure uses the connectionless mode of the signalling ~~connection bearer~~.

8.18.2 CN originated Error Indication

On the PS side, the SGSN may send an Error Indication to the RNC if it receives a G-PDU with an unknown Flow Label. The Cause Value to be used is:

- ‘Unknown Flow Label’

For the Cause Value ‘Unknown Flow Label’, both Binding Identity and Network Layer Address is mandatory.

The Binding Identity, i.e. the Flow Label, and the Network Layer Address used in the Error Indication message shall be fetched from the G-PDU that triggered the procedure.

The signalling flow for the CN originated Error Indication procedure is shown in [Figure 26](#)~~Figure 26~~~~Figure 26~~.

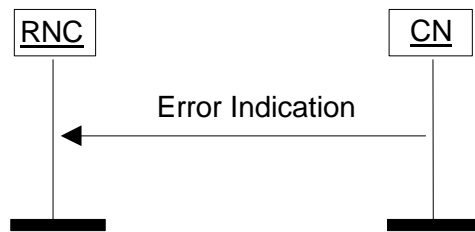

Figure ~~26~~~~26~~~~26~~. Error Indication, CN originated.

8.18.3 RNC originated Error Indication

On the PS side, the RNC may send an Error Indication to the SGSN if it receives a G-PDU with an unknown Flow Label. The Cause Value to be used is:

- 'Unknown Flow Label'

For the Cause Value 'Unknown Flow Label', both Binding Identity and Network Layer Address is mandatory.

The Binding Identity, i.e. the Flow Label, and the Network Layer Address used in the Error Indication message shall be fetched from the G-PDU that triggered the procedure.

The signalling flow for the UTRAN originated Error Indication procedure is shown in [Figure 27](#)~~Figure 27~~~~Figure 27~~.

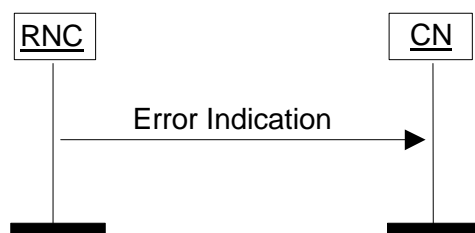

Figure ~~27~~~~27~~~~27~~. Error Indication, RNC originated.

9 Elements for RANAP communication

9.1 Message contents

[Editor's note: It has been agreed that the editor will propose a logical categorisation for messages and information elements.]

For each message there is, a table listing the signalling elements in their order of appearance in the transmitted message.

All the RANAP messages are listed in the following table:

<u>Message name</u>	<u>Reference</u>
RAB ASSIGNMENT REQUEST	
RAB ASSIGNMENT RESPONSE	
RAB RELEASE REQUEST	

IU RELEASE REQUEST	
IU RELEASE COMMAND	
IU RELEASE COMPLETE	
RELOCATION REQUIRED	
RELOCATION REQUEST	
RELOCATION REQUEST ACKNOWLEDGE	
RELOCATION COMMAND	
RELOCATION DETECT	
RELOCATION COMPLETE	
RELOCATION PREPARATION FAILURE	
RELOCATION FAILURE	
RELOCATION CANCEL	
RELOCATION CANCEL ACKNOWLEDGE	
PAGING	
COMMON ID	
CN INVOKE TRACE	
CIPHER MODE COMMAND	
CIPHER MODE COMPLETE	
CIPHER MODE REJECT	
LOCATION REPORTING CONTROL	
LOCATION REPORT	
INITIAL UE MESSAGE	
DIRECT TRANSFER	
CN INFORMATION BROADCAST REQUEST	
CN INFORMATION BROADCAST CONFIRM	
CN INFORMATION BROADCAST REJECT	
OVERLOAD	
RESET	
RESET ACKNOWLEDGE	
ERROR INDICATION	

Message name	Reference
RAB ASSIGNMENT REQUEST	
RAB ASSIGNMENT RESPONSE	
RAB RELEASE REQUEST	
COMMON ID	
DIRECT TRANSFER	
INITIAL UE MESSAGE	
LOCATION REPORTING CONTROL	
LOCATION REPORT	
CIPHER MODE COMMAND	
CIPHER MODE COMPLETE	
CIPHER MODE REJECT	
PAGING	
IU RELEASE COMMAND	
IU RELEASE COMPLETE	
IU RELEASE REQUEST	
RELOCATION REQUIRED	
RELOCATION REQUEST	
RELOCATION REQUEST ACKNOWLEDGE	
RELOCATION COMMAND	
RELOCATION DETECT	
RELOCATION COMPLETE	
RELOCATION PREPARATION FAILURE	
RELOCATION FAILURE	
RELOCATION CANCEL	
RELOCATION CANCEL ACKNOWLEDGE	
RESET	
RESET ACKNOWLEDGE	
OVERLOAD	
CN INVOKE TRACE	

CN INFORMATION BROADCAST REQUEST	
CN INFORMATION BROADCAST CONFIRM	
CN INFORMATION BROADCAST REJECT	
ERROR INDICATION	

Table 1. List of RANAP messages.

9.1.1 RAB ASSIGNMENT REQUEST

Information element	Reference	Type
Message type		M
RABs x n to be setup or modified		C1
RAB ID		M
NAS Binding Information		M
RAB parameters		M (1)
User Plane mode		M
Transport Address		M
Iu transport association		M
Priority level and pre-emption indication		O (2)
RAB linking		O
RABs x n to be released		C1
RAB ID		M
Cause		M

C1 At least one group shall be present.

- (1) This includes all the necessary parameters for RAB's (both for MSC and SGSN) including QoS.
- (2) It needs to be clarified how this parameter is in relation to priority parameters already included with the RAB parameters.

Note. It needs to be clarified how the re-ordering information as proposed in Tdoc 276 relates to QoS attribute SDU in-sequence delivery.

9.1.2 RAB ASSIGNMENT RESPONSE

Information element	Reference	Type
Message type		M
Location Identifier		O
RABs x n established or modified		C1
RAB ID		M

RAB parameters		O (1)
Transport address		M (2)
Iu transport association		M (2)
RABs x n released		C1
RAB ID		M
RABs x n queued		C1
RAB ID		M
RABs x n failed to establish or modify		C1
RAB ID		M
Cause		M
RABs failed to release		C1
RAB ID		M
Cause		M

C1 At least one group shall be present.

- (1) RAB parameters are needed only if something has changed.
- (2) Always present for SGSN.

9.1.3 RAB RELEASE REQUEST

Information element	Reference	Type
Message type		M
RABs x n to be released		C1
RAB ID		M
Cause		M

C1 At least one group shall be present.

IU RELEASE REQUEST

Information element	Reference	Type
Message type		M
Cause		M

9.1.13 IU RELEASE COMMAND

Information element	Reference	Type
Message type		M
Cause		M

IU RELEASE COMPLETE

Information element	Reference	Type
Message type		M

RELOCATION REQUIRED

Information element	Reference	Type
Message type		M
Cause		M
Source ID		M
Target ID		M (1)
Source RNC to target RNC transparent container		M

(1) The usage and format of this information element is FFS.

RELOCATION REQUEST

Information element	Reference	Type
Message type		M
Cause		M
Source RNC to target RNC transparent container		M
RABs x n to be setup		M
RAB ID		M
RAB parameters		M
User Plane mode		M
Transport address		M
Iu transport association		M
Priority level and pre-emption indication		O
RAB linking		O

RELOCATION REQUEST ACKNOWLEDGE

Information element	Reference	Type
Message type		M
Target RNC to source RNC transparent container		O (1)
RABs x n		O (2)
RAB ID		M
Transport address		M (3)
Iu transport association		M (3)

(1) Required only via one CN entity.

(2) Always present for SGSN, and present for MSC if parameters have been modified by target RNC.

(3) Always present for SGSN.

RELOCATION COMMAND

Information element	Reference	Type
Message type		M
Target RNC to source RNC transparent container		O (1)

(1) Required only via one CN entity.

RELOCATION DETECT

Information element	Reference	Type
Message type		M

RELOCATION COMPLETE

Information element	Reference	Type
Message type		M

RELOCATION PREPARATION FAILURE

Information element	Reference	Type
Message type		M
Cause		M

RELOCATION FAILURE

Information element	Reference	Type
Message type		M
Cause		M

RELOCATION CANCEL

Information element	Reference	Type
Message type		M
Cause		M

RELOCATION CANCEL ACKNOWLEDGE

Information element	Reference	Type
Message type		M

9.1.12 PAGING

Information element	Reference	Type
Message type		M
CN Domain Indicator		M
IMSI		M
Temporary UE ID		O
Paging area ID		O
Paging Cause		O

9.1.4 COMMON ID

Information element	Reference	Type
Message type		M
Permanent NAS UE Identity (e.g. IMSI)		M

9.1.29 CN INVOKE TRACE

Information element	Reference	Type
Message type		M
Trace Type		M
Trigger ID		O
Trace Reference		M
UE Identity		O
OMC ID		O

9.1.9 CIPHER MODE COMMAND

Information element	Reference	Type
Message type		M
Encryption Information		M (1)

(1) Encryption information includes key(s) and permitted algorithms.

Note 1. It is FFS whether the NAS information should be included in this message.

Note 2. The possibility to cipher only some of the RABs is FFS.

9.1.10 CIPHER MODE COMPLETE

Information element	Reference	Type
Message type		M
Chosen Encryption Algorithm		O

Note 1. It is FFS whether the NAS information should be included in this message.

CIPHER MODE REJECT

Information element	Reference	Type
Message type		M
Cause		M

9.1.7 LOCATION REPORTING CONTROL

Information element	Reference	Type
Message type		M
Request type		M

9.1.8 LOCATION REPORT

Information element	Reference	Type
Message type		M
Location Information		M
Cause		O

9.1.6 INITIAL UE MESSAGE

Information element	Reference	Type
Message type		M
Location Information		M
NAS Layer 3 Information		M

DIRECT TRANSFER

Information element	Reference	Type
Message type		M
NAS PDU		M

9.1.30 CN INFORMATION BROADCAST REQUEST

Information element	Reference	Type
Message type		M
CN Domain Indicator		M
CN System Information piece x n		C1
NAS bit string		M
Broadcast area		M
Categorisation parameters		M

C1 At least one group must be present.

Note 1. It is FFS how the broadcasting is turned off.

9.1.31 CN INFORMATION BROADCAST CONFIRM

Information element	Reference	Type
Message type		M

9.1.32 CN INFORMATION BROADCAST REJECT

Information element	Reference	Type
Message type		M
Cause		M

[Editor's note: The CONFUSION message is removed, since it is not included in procedure descriptions and no parameters are included for this message either.]

9.1.28 OVERLOAD

Information element	Reference	Type
Message type		M
Number of steps		O

9.1.26 RESET

Information element	Reference	Type
Message type		M
Cause		M

9.1.27 RESET ACKNOWLEDGE

Information element	Reference	Type
Message type		M

9.1.33 ERROR INDICATION

Information element	Reference	Type
Message type		M
Cause		M
Binding ID		O
Source Network Layer Address		O

9.2 Information element definitions

[Study item 7: Usage of ASN.1 and encoding rules versus the description of information elements in TTC/ARIB document.]

Radio network layer related IEs

9.2.1 Message type

Message type uniquely identifies the message being sent. It is mandatory for all messages.

9.2.2 RAB ID

[Editor's note: This definition needs to be harmonized with UMTS 23.10.]

This ID is to identify a particular radio access bearer in Iu.

9.2.4 RAB parameters

The purpose of the RAB parameter information element is to indicate all RAB parameters for both directions, e.g. Quality of service (QoS) classes.

9.2.7 Cause

The cause element is used to indicate the reason for a particular event to have occurred according to the cause code list.

9.2.8 Priority level and pre-emption indication

Indicates the priority of the request.

9.2.9 RAB linking

A group of RABs which must be either all established, or all rejected.

9.2.10 Location Identifier

Indicates location of the UE.

9.2.12 CN Domain Indicator

Indicates the CN domain from which the message originates or to which the message shall be sent ~~to which domain (MSC or SGSN) the paging shall be directed.~~

9.2.16 Trace Type

A fixed length element indicating the type of trace information to be recorded.

9.2.17 Trigger ID

A variable length element indicating the identity of the entity which initiated the trace.

9.2.18 Trace Reference

A fixed length element providing a trace reference number allocated by the triggering entity.

9.2.19 UE Identity

Indicates the identity of the UE.

9.2.20 OMC ID

A variable length element indicating the destination OMC to which trace information is to be sent.

~~9.2.21~~ Encryption Information

This element contains the user data encryption information (key(s) and permitted algorithms) used to control any encryption equipment at the RNC.

~~9.2.22~~ Chosen Encryption Algorithm

This element indicates the encryption algorithm being used by the RNC.

~~9.2.24~~ Broadcast Area

With each bit string, a geographical area where to broadcast it.

~~9.2.25~~ Categorisation parameters

With each bit string, to be used by the RNC to determine how to schedule the repetition cycle.

~~9.2.27~~ Request Type

[Editor's note: This definition needs to be harmonized with UMTS 23.10.]

This information request the information type that to be reported from RNC, e.g. to report LAI and RAI of the current UE location. Other request types are FFS.

~~9.2.28~~ Location Information

[Editor's note: This definition needs to be harmonized with UMTS 23.10.]

This information shows the location information that has been requested by the CN, e.g. LAI and RAI. Other types of location information are FFS.

~~9.2.30~~ User Plane Mode

[Editor's note: It has been agreed that the editor will propose a definition for this.]

User Plane Mode IE indicates the Iu user plane mode to be used for the RAB. Three modes exist: Transparent, Support Mode for predefined PDU sizes and support mode for variable PDU sizes. The Iu user plane modes are defined in UMTS 25.415.

~~9.2.31~~ Paging Area ID

[Editor's note: It has been agreed that the editor will propose a definition for this.]

Paging Area ID is the identifier of the area in which the CN desires to page the the UE. The Paging area ID may be e.g. a Location Area ID or Routing Area ID.

~~9.2.32~~ Source ID

[Editor's note: It has been agreed that the editor will propose a definition for this.]

Source ID identifies the source for the relocation of SRNS. The Source ID may be e.g. Source RNC-ID or serving cell ID.

~~9.2.33~~ Target ID

[Editor's note: It has been agreed that the editor will propose a definition for this.]

Target ID identifies the target for the relocation of SRNS. The target ID may be e.g. Target RNC-ID (for UMTS-UMTS relocation) or Global Cell ID of the relocation target (in case of UMTS to GSM relocation).

9.2.34 Source RNC to Target RNC Transparent Container

[Editor's note: It has been agreed that the editor will propose a definition for this.]

Source RNC to Target RNC Transparent Container IE is an information element that is produced by Source RNC and is transmitted to target RNC. In inter system relocation the IE is transmitted either from external relocation source to target RNC or from source RNC to the external relocation target.

This IE is transparent to CN.

9.2.35 Target RNC to Source RNC Transparent Container

[Editor's note: It has been agreed that the editor will propose a definition for this.]

Target RNC to Source RNC Transparent Container IE is an information element that is produced by Target RNC and is transmitted to Source RNC. In inter system relocation the IE is transmitted either from external relocation target to source RNC or from target RNC to the external relocation source.

This IE is transparent to CN.

9.2.36 Number of steps

Indicates the number of steps to reduce traffic in overload situation.

Transport network layer related IEs

9.2.5 Transport address

To be used for the user plane transport.

9.2.6 lu transport association

This element is used to associate the RAB and the corresponding user plane connection.

NAS related IEs

9.2.3 NAS Binding Information

[Editor's note: This definition needs to be harmonized with UMTS 23.10.]

This information is a information transmitted transparently to the RNC.

9.2.11 Permanent NAS Identity

This ID is common for mobile terminal and is used by the RNC to check if SRB is already existing (from other NE) to the UE when new radio access bearer is in establishment phase. Initially this is of the type of IMSI. The future usage is FFS.

IMSI

International Mobile Subscriber Identity, identifies a subscriber.

9.2.14 Temporary UE ID

Temporary Mobile Subscriber Identity, used for security reasons to hide the identity of a subscriber.

9.2.15 Paging Cause

Tells the cause of paging to the UE.

9.2.23 NAS Bit String

The NAS information peace to be broadcast. The internal structure of this bit string is not known or analysed by the RNC, and is specified as part of the CN - UE protocols.

9.2.26 NAS PDU

This information element contains the CN – UE or UE – CN message that is transferred without interpretation in the RNC. Typically it contains call control and mobility management messages.

9.2.29 NAS Layer 3 Information

This is a variable length element used to pass radio interface messages from one network entity to another.

9.3 Message and Information element abstract syntax (with ASN.1)

```
-- *****
--
-- PDU descriptions for RANAP.
--
-- *****

RANAP-PDU-descriptions -- { object identifier to be allocated }--
DEFINITIONS AUTOMATIC TAGS ::=

BEGIN

-- *****
--
-- PDU content types from the PDU module.
--
-- *****

IMPORTS
-- Imports PDU content types from RANAP PDU contents module
-- ** TO BE DEFINED **
    ExampleMessageContents1,
    ExampleMessageContents2-v1,
    ExampleMessageContents2-v2,
    ExampleMessageContents3
FROM RANAP-PDU-contents;

-- *****
--
-- Table column structure.
--
-- RANAP-PDU-DESCR associates a RANAP PDU structure with a PDU
-- identifier.
--
-- *****

RANAP-PDU-DESCR ::= CLASS {
    &PDUType,
    &versionID      VersionID  UNIQUE,
    &LogicalProcedure  LogicalProcedure
}
WITH SYNTAX {
    PDU TYPE      &PDUType
    VERSION NUMBER AND ID      &versionID
    LOGICAL PROCEDURE      &LogicalProcedure
}

-- ** TO BE DEFINED **
VersionID ::= SEQUENCE {
    pduID      INTEGER (0..63),
    versionNumber      VersionNumber
}

```

```

-- *** TO BE DEFINED ***
VersionNumber ::= INTEGER (1 .. 255)

-- *** TO BE DEFINED ***
LogicalProcedure ::= ENUMERATED {
    global,
    dedicated
}

-- *****
--
-- Table row definitions.
--
-- RANAP PDU descriptions.
--
-- *****

RANAP-PDUs RANAP-PDU-DESCR ::= {
    -- *** TO BE DEFINED ***
    exampleMessage1 |
    exampleMessage2-v1 |
    exampleMessage2-v2 |
    exampleMessage3 |

    -- Additional PDU descriptions can be added in future
    ...
}

-- *** TO BE DEFINED ***
exampleMessage1 RANAP-PDU-DESCR ::= {
    PDU TYPE          ExampleMessageContents1
    VERSION NUMBER AND ID { pduID 1, versionNumber 1 }
    LOGICAL PROCEDURE { global }
}

exampleMessage2-v1 RANAP-PDU-DESCR ::= {
    PDU TYPE          ExampleMessageContents2-v1
    VERSION NUMBER AND ID { pduID 2, versionNumber 1 }
    LOGICAL PROCEDURE { dedicated }
}

exampleMessage2-v2 RANAP-PDU-DESCR ::= {
    PDU TYPE          ExampleMessageContents2-v2
    VERSION NUMBER AND ID { pduID 2, versionNumber 2 }
    LOGICAL PROCEDURE { dedicated }
}

exampleMessage3 RANAP-PDU-DESCR ::= {
    PDU TYPE          ExampleMessageContents3
    VERSION NUMBER AND ID { pduID 3, versionNumber 1 }
    LOGICAL PROCEDURE { global | dedicated }
}

-- *****
--
-- Generic PDU structure. The RANAP-PDUs table above describes
-- valid contents for the vid, indication and value fields.
--
-- *****

RANAP-PDU ::= SEQUENCE {
    vid          RANAP-PDU-DESCR.&versionID ({RANAP-PDUs}),
    value       RANAP-PDU-DESCR.&PDUType  ({RANAP-PDUs}{@vid})
}

END

```

```

-- *****
--
-- RANAP PDU content definitions
--
-- *****

RANAP-PDU-contents DEFINITIONS AUTOMATIC TAGS ::=

BEGIN

-- IMPORTS

```

```

-- *** TO BE DEFINED ***
-- FROM RANAP-IEs

-- *** TO BE DEFINED ***
-- FROM RANAP-Constants;

-- Definitions of RANAP PDU content types one by one
-- *** TO BE DEFINED ***

ExampleMessageContents1 ::= SEQUENCE {
    -- *** IEs to be defined ***
    ...
}

ExampleMessageContents2-v1 ::= SEQUENCE {
    -- *** IEs to be defined ***
    ...
}

ExampleMessageContents2-v2 ::= SEQUENCE {
    -- *** IEs to be defined ***
    ...
}

ExampleMessageContents3 ::= SEQUENCE {
    -- *** IEs to be defined ***
    ...
}

END

```

```

-- *****
--
-- RANAP Information Elements
--
-- *****

RANAP-IEs DEFINITIONS AUTOMATIC TAGS ::=

BEGIN

-- IMPORTS

-- *** TO BE DEFINED ***
-- FROM RANAP-Constants;

-- Definitions of RANAP IEs one by one
-- *** TO BE DEFINED ***

END

```

```

-- *****
--
-- Constant definitions for RANAP
--
-- *****

RANAP-Constants DEFINITIONS AUTOMATIC TAGS ::=

BEGIN

-- Definitions of RANAP constants one by one
-- *** TO BE DEFINED ***

END

```

9.4 Message transfer syntax

9.5 Timers

[Editor's note: This chapter should list and describe the used timers.]

10 Handling of unknown, unforeseen and erroneous protocol data

11 Annex A (normative):

Annex A Document Stability Assessment Table

Section	Content missing	Incomplete	Restructuring needed	Checking needed	Editorial work required	Finalisation needed	Almost stable	Stable
1	√							
2					√			
3				√				
4	√							
5	√							
6	√							
7				√				
8						√		
9		√			√			
10	√							

12 History

Document history		
0.0.1	February 1999	Document skeleton created.
0.0.2	February 1999	Relevant sections from Merged "Description of Iu Interface" have been introduced.

0.0.3	March 1999	<p>The results of the solved study items Iu/2, Iu/3, Iu/4 and Iu/6 have been updated to the text.</p> <p>The heading of section 8 has been changed to "RANAP procedures".</p>
0.0.4	April 1999	<p>Editorial changes:</p> <ul style="list-style-type: none"> - References to "Merged Description of Iu Interface" have been removed. - Remaining instances of Signalling Channel Setup and Response procedure have been removed. - In Hard HO procedure it has been corrected that target RNC receives RELOCATION COMMIT message from source RNC.
0.0.5	April 1999	<p>Editorial changes:</p> <ul style="list-style-type: none"> - Words "Radio Access", related to radio access bearer setup, reconfiguration and release messages, have been added in front of those messages where it was missing. - RAB Release procedure updated to return RAB ASSIGNMENT COMPLETE message before User plane release.
0.1.0	April 1999	Same as 0.0.5, approved by WG3.
1.0.0	April 1999	Approved by TSG RAN. Same contents as 0.1.0.
1.0.1	May 1999	<p>Main updates made based on WG3 meeting #3 and other decisions:</p> <ul style="list-style-type: none"> • Specification number changed to UMTS 25.413. • Title changed to UTRAN Iu Interface RANAP Signalling. • SRNS Relocation and Inter RNS Hard HO procedures merged to a Relocation procedure with a split to elementary procedures according to Tdoc R3-99339 with agreed modifications. The merging was possible based on the approved Tdoc R3-99340, which added RELOCATION DETECT message to the SRNS Relocation procedure. • A statement in the Relocation procedure added related to the load sharing on the Iu-PS interface, according to Tdoc R3-99257 with modifications. • Location Request and Location Report procedures added according to Tdoc R3-99358 with agreed modifications. • Information elements for Relocation procedure have been added according to Tdoc R3-99328 with modifications.

1.0.2	June 1999	<p>Main updates made based on WG3 meeting #4 decisions:</p> <ul style="list-style-type: none"> • Relocation Required Indication procedure replaced by Relocation Preparation procedure according to R3-99477 with agreed modifications. • It was decided to use combined RAB Assignment procedure based on solved Study item Iu/5. • Location Request procedure was replaced by Location Reporting Control procedure according to R3-99475 with agreed modifications. • RANAP Error Indication procedure was introduced according to R3-99456. • CN domain indicator to Paging procedure was accepted according to R3-99461. • Information elements for RAB Assignment procedure were agreed according to R3-99503 with modifications. • Some minor editorial changes made.
1.1.0	July 1999	Same as v. 1.0.2 approved in RAN WG3 and raised to v. 1.1.0.
1.1.1.	July 1999	<p>Main updates made based on WG3 meeting #5 decisions:</p> <ul style="list-style-type: none"> • Description and definition of elementary procedure added according to R3-99727 with modifications. List of elementary procedures included. • As a result of R3-99727, Iu Release Request changed to an elementary procedure. Text proposed by the Editor. • Failure handling added to Relocation procedure based on R3-99746 with modifications. • Relocation cancel elementary procedure added according to R3-99745 with modifications. • Bearer ID changed to RAB ID and NAS Binding ID added according to R3-99747. • User Plane Mode parameter added to RAB Assignment and Relocation procedures according to R3-99720. • The Cause parameter added and Transparent field changed to mandatory in RELOCATION REQUIRED and RELOCATION REQUEST messages according to R3-99678. • The parameters for Location Reporting Control and Location Report procedures were agreed according to R3-99748. • The message contents for the remaining procedures and parameter definitions added based on R3-99670 with modifications.
1.1.2	August 1999	'Cause' parameter removed from Overload procedure description. Minor editorial changes.
1.2.0	August 1999	Version 1.1.2 approved in WG3#6 and raised to v. 1.2.0.

1.2.1	September 1999	<p>Decisions from WG3#6 have been updated as follows:</p> <ul style="list-style-type: none"> • RAB Assignment procedure rewritten according to Tdoc R3-99A74 (=updated Tdoc R3-99942) with modifications. Type Class 3 of Elementary Procedure introduced. • RAB Release Request procedure added according to Tdoc R3-99A09. • List of RANAP functions added according to Tdoc R3-99A01 with modifications. • 'Transparent field' changed to 'Transparent container' according to Tdoc R3-99952. • A concept of handling relocation co-ordination in source and target RNC added according to Tdoc R3-99A10 with modifications. • Handling of the crossing of RESET messages was included as proposed in Tdoc R3-99909. • Editorial comments proposed in Tdoc R3-99940 included with modifications. • Definitions in Tdoc R3-99A60 added with modifications.
1.2.2	September 1999	<p>Some additional updates made to fulfil the agreements from WG3#6:</p> <ul style="list-style-type: none"> • The definition of Class 3 Elementary Procedure clarified. • The 'Overload' and 'Location Report' procedures have been updated according to the agreements in WG3#6. • The description of 'Iu Release' and 'Cipher Mode Control' procedures has been further updated to better reflect the decisions in WG3#6. • The possibility of RAB release to fail added also into the message contents of RAB ASSIGNMENT RESPONSE. • Some other minor editorial updates.
<u>1.2.3</u>	<u>September 1999</u>	<p><u>Editor's proposals according to WG3#6 agreements:</u></p> <ul style="list-style-type: none"> • <u>Section 'Scope' has been rewritten.</u> • <u>Missing IE definitions have been proposed.</u> • <u>The order of describing procedures, message contents and IE definitions has been changed.</u> • <u>Proposed to replace 'signalling connection' by 'signalling bearer' in some instances.</u> • <u>Proposed to remove the paragraph regarding load sharing on the Iu PS interface in section 8.6.3 Relocation resource allocation.</u>
Rapporteur for 3GPP UMTS 25.413 is:		
<p>Jyrki Jussila Nokia Telecommunications Tel.: +358 9 5113 8436 Fax : +358 9 5113 8452 Email : jyrki.jussila@nokia.com</p>		
This document is written in Microsoft Word version 7.0/96.		