

Agenda Item: 19.1
Source: Alcatel
Title: Priority handling at AAL2 and ATM layer on the Iub/Iur interfaces.
Document for: Decision

1. Introduction

Asynchronous Transfer Mode (ATM) and ATM Adaptation Layer type 2 (AAL2) are used as a transport layer for data streams on Iur and Iub interfaces on the user plane.

AAL2 is designed for “the bandwidth-efficient transmission of **low-rate, short**, variable length packets **in delay sensitive applications**” (see [1]).

Nevertheless, on the Iub and Iur interfaces, AAL2 is used for all circuit-switched and packet-switched user data. Thus AAL2 will transmit **possibly high rate** (up to 2 Mbit/s), **possibly long** (e.g. when the transmission time interval is 80 ms), variable length packets of **applications requiring different types of quality of services**.

TS22.105 ([2]) defines 4 traffic classes, which have different delay characteristics (conversational, interactive, streaming and background). In 23.907, priority handling is mentioned for interactive and background classes.

The question is **how to handle these different traffic classes at AAL2 and ATM layers** on the Iub and Iur interfaces.

Two approaches to multiplex AAL2 channels on the Iub/Iur interfaces can be foreseen.

2. First approach : No distinction of QoS is made at AAL2 and ATM layers

All AAL2 channels are handled in the same way regardless of the QoS requirements of upper applications. QoS requirements at AAL2/ATM layers are not distinguished.

Thus, all AAL2 channels will be transported with the best quality of service on the Iub and Iur interfaces. They will be transported as delay sensitive connections requiring a low loss probability, even if the applications are non real time or best effort.

This approach is simple and in line with [1].

Nevertheless, with this approach, **no statistical multiplexing** can be done at AAL2 and at ATM level. **The required ATM bandwidth on the Iub and Iur interface is larger** than if some statistical multiplexing is done.

Transmission resource inside the UTRAN should be optimized. Decreasing the ATM required bandwidth for the same net bit rate can allow an operator to decrease its transmission and operating cost.

This major drawback leads to a second approach: QoS requirements of upper applications are handled at AAL2 or ATM layer.

2.1. Second Approach : QoS handling at AAL2/ATM layer

QoS is handled at AAL2 or ATM level. Priority classes should be defined at AAL2 level in order to distinguish QoS requirements of every AAL2 connections.

Two ways to handle Priority at AAL2 or ATM level can be foreseen.

1. Priority handled at AAL level: AAL2 channels with the different QoS requirements are multiplexed in the same VCC. VCC will be transported with the best quality of service inside ATM network.
2. Priority handled at ATM level: A VC connection is dedicated to one Priority. AAL2 channels with the same QoS requirements are multiplexed in the same VCC.

Statistical multiplexing gain is possible.

The required bandwidth of the VCC carrying AAL2 channels is lower than if no statistical multiplexing is done. This is shown in the simulation results below.

3. Comparison of multiplexing strategies

Simulations have been launched to compare these two approaches with two Priority classes.

Real time and non real time AAL2 connections are multiplexed in one VCC. QoS is handled at AAL2 level (second approach) or it is not handled (first approach). The service category of the VC connection is Constant Bit Rate. The Peak Cell Rate of this VCC is 2 Mbit/s.

Real time sources are of speech type. As an example, the AAL SDU length is **33 octets**, taking into account the length of frame of 20 ms (*Transmission Time Interval*) with a variable bit rate due to the AMR, plus octets for quality estimation. The arrival process of AAL SDU is periodic.

Non real time sources are data sources with cut-off Pareto arrival process, according to the model defined in [5], which leads to maximum AAL SDU length of **1440 octets** and minimum AAL SDU length of **235 octets** (80 ms TTI).

The percentage of real time traffic varies between 25 and 75%. To represent an efficient use of the transmission medium, **the global load is always constant, equal to 0.7**, where the global load is defined as the ratio between the actual resulting bit rate of all established connections and the bit rate of the VCC (a 2 Mbit/s VCC is chosen, as a representative example of an Iub interface link). The global load is a fundamental parameter, as it roughly represents the efficiency of the transmission. In ATM networks, a load of 0.8 or even higher is often considered as a reasonable objective for peak hours.

Figures below show the mean and maximum delay of real time and non real time AAL2 channels versus the percentage of real time octets. The maximum delay is supposed to be the 10^{-5} quantile of the delay distribution (more precisely, the probability that the transfer delay is greater than the max. is less than 10^{-5}). The delay is the one introduced in the packing queue between AAL2 and ATM layer.

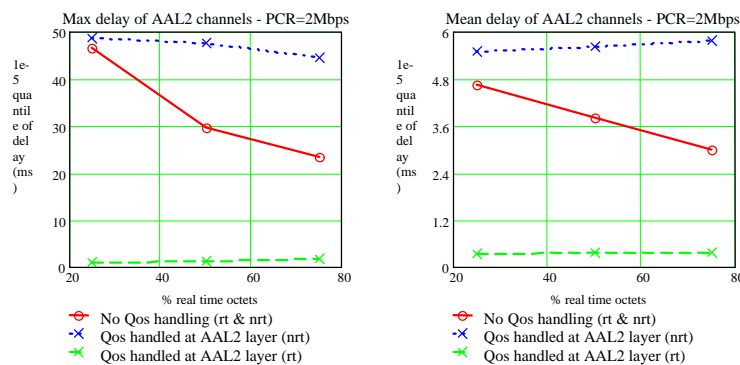

These figures show that if no QoS is handled at AAL2 level, real time AAL2 connections can encounter unacceptable delays (between 23 and 47 ms). If QoS is handled at AAL2 level, real time AAL2 connections always encounter a delay less than 2 ms.

This implies that the load of 0.7 cannot be obtained if no priority is distinguished. For the same delay characteristics for real time traffic, the Peak Cell Rate of the ATM VCC would have to be increased and the load of the VCC should be decreased.

It can be shown that **it is not possible to accept both one data connection following the Pareto distribution above (144 kbit/s Peak rate) and one speech connection on a 2 Mbit/s VCC**, while keeping a transmission delay over the Iub interface less than 5 ms for the speech connection, if the priority is ignored at ATM and AAL level. This can be simply explained as follows: In the model, the max. AAL SDU size is 1440 octets, packed into 33 ATM cells and corresponding to a Time Transmission Interval of 80 ms. If a speech frame arrives just after a max size AAL SDU has been queued on the VCC, it will have to wait 33 cell time units before starting to be transmitted, which correspond to about 7 ms. The probability of this event is high enough to hit the 10^{-5} quantile of the delay distribution of the speech connection.

These results have shown that the approach without priority handling is not acceptable, and that a priority handling at AAL2 layer is recommended.

4. Conclusion and proposal

It is proposed to handle QoS at AAL2 layer on the Iub and Iur interfaces. This has to be specified in TS 25.426.

The node B should know the priority associated with an AAL2 channel. Since there is no field concerning priority in [4], it is proposed to add a new parameter in the Radio Link Set Up and Radio Link Reconfiguration messages, in order to indicate the priority level to be given to the Iub transport bearer associated to each DCH transport channel. This has to be specified in TS25.433, and text proposal is provided in Tdoc 951/99.

5. Change proposal to TS 25.426

Changes are proposed in section 4.2.

4.2 Transport Layer

Asynchronous Transfer Mode (ATM) [2] and ATM Adaptation Layer type 2 (AAL2) [3, 4] are used as a transport layer for DCH data streams on Iur and Iub interfaces. Service Specific Segmentation and Reassembly (SSSAR) sublayer for AAL2 is used for the segmentation and reassembly of AAL2 SDUs.

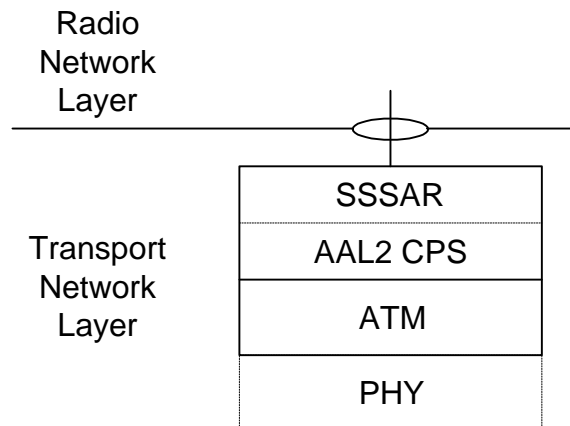

Figure 1. Transport network layer for DCH data streams over Iur and Iub interfaces.

Priority between the different transport bearers set up for each DCH is handled at AAL2 layer, using the transport priority field provided by the Radio Network Layer (NBAP), when the transport bearer is set up.

Reference :

- [1] ITU-T Recommendation I.363.2 “B-ISDN ATM Adaptation Layer Type 2 Specification”
- [2] 3G TS22.105, “Technical Specification Group Services and System Aspects. Service aspects, Services and Service Capabilities”
- [3] ITU-T Recommendation I.356 “B-ISDN ATM Layer Cell Transfer Performance”
- [4] ITU-T Recommendation Q.2630.1 “AAL Type 2 Signalling Protocol”
- [5] TR 101-112 – Selection Procedures for the choice of radio transmission technologies of the UMTS