

Agenda Item: 9.1
Source: **Editor**
Title: Editor's proposal of TS 25.415: V0.2.2
Document for: Decision

1. Introduction

At the last R3 meeting in Helsinki, significant progress of Iu UP has been made and the material contained in [1] has been supplemented with significant amount of information.

The present contribution proposes a set of modifications essentially editorial in order to enhance the document quality and propose it for revision 1.x.x.

2 References

[1] TSGR3#5(99)814, Updated Version of 0.2.1. of TS 25.415

TS RAN 25.415 V0.2.2 (1999-08)

Technical Specification

**3rd Generation Partnership Project (3GPP);
Technical Specification Group (TSG) RAN;
Working Group 3 (WG3);**

Iu Interface CN-UTRAN User Plane Protocols

UMTS 25.415



The present document has been developed within the 3rd Generation Partnership Project (3GPP™) and may be further elaborated for the purposes of 3GPP.
The present document has not been subject to any approval process by the 3GPP Organisational Partners and shall not be implemented.
This Specification is provided for future development work within 3GPP only. The Organisational Partners accept no liability for any use of this Specification.
Specifications and reports for implementation of the 3GPP™ system should be obtained via the 3GPP Organisational Partners' Publications Offices.



UMTS 25.415

(25.415.PDF)

Keywords

Digital cellular telecommunications system,
Universal Mobile Telecommunication System
(UMTS), UTRAN, CN, Iu
<keyword[, keyword]>

3GPP

Postal address

Office address

Internet

secretariat@3gpp.org
Individual copies of this deliverable
can be downloaded from
<http://www.3gpp.org>

Copyright Notification

No part may be reproduced except as authorized by written permission.
The copyright and the foregoing restriction extend to reproduction in all media.

©
All rights reserved.

Contents

Intellectual Property Rights	8
Foreword	8
1 Scope	9
2 References	9
3 Definitions, symbols and abbreviations	9
3.1 Definitions.....	9
3.2 Abbreviations.....	10
3.3 Concepts.....	11
4 General.....	11
4.1 General aspects	11
4.2 Operational and Functional aspects.....	12
4.2.1 Iu UP protocol modes of operation	12
4.2.2 Transparent mode (TrM).....	12
4.2.3 Support modes.....	13
5 Transparent mode	14
5.1 General.....	14
5.1.1 Operation of the Iu UP in Transparent mode.....	14
5.1.2 Interfaces of the Iu UP protocol layer in Transparent mode.....	14
5.2 Iu UP Protocol layer Services in Transparent mode	1544
5.3 Services Expected from the UP Data Transport layer.....	15
5.4 Elements for Iu UP communication in Transparent mode	15
5.4.1 Frames Format for transparent	15
6 Support modes	15
6.1 General.....	15
6.1.1 Operation of the Iu UP in Support mode.....	15
6.1.2 Interfaces of the Iu UP protocol layer in Support mode.....	15
6.2 Iu UP Protocol layer Services in Support mode.....	16
6.3 Services Expected from the UP Data Transport layer.....	16
6.4 Functions of the Iu UP Protocol Layer in Support mode	17
6.4.1 Functional model of the Iu UP Protocol Layer in Support mode	17
6.4.2 Frame Handler function.....	17
6.4.3 Procedure Control functions.....	17
6.4.4 Non Access Stratum Data Streams specific function(s).....	18
6.5 Elementary procedures.....	18
6.5.1 Transfer of User Data procedure	18
6.5.2 Initialisation procedure.....	18
6.5.3 Rate Control procedure (FFS)	19
6.5.4 Time Alignment procedure (FFS)	19
6.5.5 Handling of Abnormal Event procedure.....	19
6.6 Elements for Iu UP communication in Support mode.....	22
6.6.1 Frames Format for predefined size SDUs.....	22
6.6.1.1 PDU Type 0.....	22
6.6.2 Frames Format for variable size SDUs.....	23
6.6.3 Frames content definition	23
6.6.4 Frames coding	23
6.6.5 Timers	23
6.7 Handling of unknown, unforeseen and erroneous protocol data	23
7 Communication Primitives for the Iu UP protocol layer.....	25
7.1 Modelling Principle	25
7.2 Primitives towards the upper layers at the RNL SAP.....	25
7.2.1 General	25
7.2.2 Iu-UP-DATA-REQUEST.....	26

7.2.3	Iu-UP-DATA-INDICATION	27
7.2.4	Iu-UP-STATUS-REQUEST	27
7.2.5	Iu-UP-STATUS-INDICATION	27
7.2.6	Iu-UP-UNIT-DATA-REQUEST	27
7.2.7	Iu-UP-UNIT-DATA-INDICATION	27
7.3	Primitives towards the transport layers	27
7.3.1	General	27
7.3.2	Primitives at the AAL-SAP: ATM/AAL2 Transport layer	28
7.3.3	AAL2 Service Primitives used by the Iu UP protocol	28
7.3.4	Primitives at the GTP-U-SAP: GTP Transport Layer	28
8	Annex A (Normative)	3
9	Annex B (Informative): Illustration of usage of RFCI for AMR speech RAB.	3
10	Annex C (Informative) Document Stability Assessment Table	6
11	History	6
	Intellectual Property Rights	6
	Foreword	6
1	Scope	7
2	References	7
3	Definitions, symbols and abbreviations	7
3.1	Definitions	7
3.2	Symbols	8
3.3	Abbreviations	8
3.4	Concepts	8
4	General	8
4.1	Architectural aspects	8
4.2	Operational and Functional aspects	8
5	Support mode	9
5.1	General	9
5.1.1	Operation of the Iu UP in Support mode	9
5.1.2	Interfaces of the Iu UP protocol layer in Support mode	9
5.2	Iu UP Protocol layer Services in Support mode	10
5.3	Services Expected from the UP Data Transport layer	10
5.4	Functions of the Iu UP Protocol Layer in Support mode	10
5.5	Elementary procedures	12
5.5.1	Initialisation procedure	12
5.6	Primitives for the Support Mode	13
5.6.1	Primitives for the Support Mode for predefined size SDUs	13
5.6.1.1	Principle	13
5.6.1.2	Primitives towards the upper layers at the RNL SAP	13
5.6.1.3	Iu UP DATA REQUEST	14
5.6.1.4	Iu UP DATA INDICATION	14
5.6.1.5	Iu UP STATUS	14
5.6.1.6	Primitives towards the transport layers at the AAL SAP	15
5.6.1.7	ATM/AAL2 Transport layer	15
5.6.1.8	AAL2 Service Primitives used by the Iu UP protocol	15
5.6.1.9	Primitives towards the transport layers at the GTP U SAP	15
5.6.1.10	GTP Transport Layer	15
5.6.2	Primitives for the Support Mode for variable size SDUs	16
5.7	Elements for Iu UP communication in Support mode	16
5.7.1	Frames Format for predefined size SDUs	16
5.7.1.1	PDU Type 0	16
5.7.2	Frames Format for variable size SDUs	17
5.7.3	Frames content definition	17
5.7.4	Frames coding	17

5.7.5	Timers	17
5.8	Handling of unknown, unforeseen and erroneous protocol data	17
6	Transparent mode	17
6.1	General	17
6.1.1	Operation of the Iu-UP in Transparent mode	17
6.2	Primitives for the Transparent Mode	18
6.2.1	Principle	18
6.2.2	Primitives towards the upper layers at the RNL SAP	18
6.2.2.1	Iu-UP-UNIT-DATA-REQUEST	19
6.2.2.2	Iu-UP-UNIT-DATA-INDICATION	19
6.2.3	Primitives towards the transport layers at the AAL-SAP	19
6.2.3.1	ATM/AAL2 Transport layer	19
6.2.3.2	AAL2 Service Primitives used by the Iu-UP protocol	19
6.2.4	Primitives towards the transport layers at the GTP-SAP	19
6.2.4.1	GTP Transport Layer	20
7	Annex A (Normative)	20
8	Annex B (Informative): Illustration of usage of RFCI for AMR speech RAB	20
9	Annex C (Informative) Document Stability Assessment Table	22
10	History	22

Intellectual Property Rights

IPRs essential or potentially essential to the present deliverable may have been declared to 3GPP and/or its organizational partners. The information pertaining to these essential IPRs, if any, is publicly available for **3GPP members and non-members, free of charge**. This can be found in the latest version of the 3GPP Technical Report:

[reference tbd.]

Pursuant to the 3GPP Interim IPR Policy, no investigation, including IPR searches, has been carried out by 3GPP. No guarantee can be given as to the existence of other IPRs not referenced in the [tbd.], which are, or may be, or may become, essential to the present document.

Foreword

This Technical Specification has been produced by the 3rd Generation Partnership Project, Technical Specification Group RAN WG3.

The contents of this TS may be subject to continuing work within the 3GPP and may change following formal TSG approval. Should the TSG modify the contents of this TS, it will be re-released with an identifying change of release date and an increase in version number as follows:

Version m.t.e

where:

- m indicates [major version number]
- x the second digit is incremented for all changes of substance, i.e. technical enhancements, corrections, updates, etc.
- y the third digit is incremented when editorial only changes have been incorporated into the specification.

4 Scope

This Technical Specification defines the Radio Network Layer user plane -protocols being used ~~to transport and control~~ over the Iu interface, ~~the Iu User Data Streams~~.

2 References

The following documents contain provisions, which, through reference in this text, constitute provisions of the present document.

- References are either specific (identified by date of publication, edition number, version number, etc.) or non-specific.
- For a specific reference, subsequent revisions do not apply.
- For a non-specific reference, the latest version applies.
- A non-specific reference to an ETS shall also be taken to refer to later versions published as an EN with the same number.

- [1] [UMTS 25.401, 3rd Generation Partnership Project \(3GPP\) Technical Specification Group \(TSG\) RAN; UTRAN Overall Description Architecture](#)
- [2] [UMTS 25.410, 3rd Generation Partnership Project \(3GPP\) Technical Specification Group \(TSG\) RAN; UTRAN Iu interface: general Aspects and Principles](#)
- [32] [UMTS 25.413, 3rd Generation Partnership Project \(3GPP\) Technical Specification Group \(TSG\) RAN; UTRAN Iu interface RANAP protocol](#)
- [43] [UMTS 25.414, 3rd Generation Partnership Project \(3GPP\) Technical Specification Group \(TSG\) RAN; Iu Interface Data Transport and Transport Signalling](#)
- [54] [UMTS 23.110, 3rd Generation Partnership Project \(3GPP\) Technical Specification Group \(TSG\) SSA, UMTS Access Stratum, services and functions](#)
- [6] [UMTS 23.121, 3rd Generation Partnership Project \(3GPP\) Technical Specification Group \(TSG\) SSA, Architectural requirements for Release 99](#)
- [75] ITU-T Recommendation I.363.2 (1997) - B-ISDN ATM Adaptation Layer type 2 specification
- [86] ITU-T Recommendation I.366.1 (1998) - Segmentation and reassembly service specific convergence sublayer for the AAL type 2
- [9] [UTRAN Vocabulary](#)

3 Definitions, symbols and abbreviations

3.1 Definitions

For the purposes of the present document, the following terms and definitions apply.

Non Access Stratum (NAS) Data Streams:

Non Access Stratum Data Streams is a generic term to identify in the CN and the Terminal domains, these data streams exchanged at the Dedicated Service Access Points between the Non Access Stratum and the Access Stratum.

RAB sub-flows: A RAB as defined in [9] can be realised by UTRAN through several sub-flows. These sub-flows correspond to the NAS service data streams that have QoS characteristics that differ in a predefined manner within a RAB e.g. different reliability classes.

RAB sub-flows characteristics:

1. The sub-flows of a RAB are established and released together at the RAB establishment and release, respectively
2. The sub-flows of a RAB are submitted and delivered together at the RAB SAP
3. The sub-flows of a RAB are carried over the same Iu transmission connection
4. The sub-flows of a RAB are organised in a predefined manner at the SAP and over the Iu interface. The organisation is imposed by the NAS as part of its co-ordination responsibility.

RAB sub-flows numbering (applies to support mode for predefined SDU size only):

1. RAB sub-flows are numbered from 1 to N (N is the number of sub-flows)
2. RAB sub-flow number 1 corresponds to the highest reliability class and the RAB sub-flow number N corresponds to the lowest reliability class.

Note: It is FFS whether numbering of subflows can be based on something else than reliability classes.

3. RAB sub-flows order inside the Iu frame is predefined so that RAB sub-flow number one comes first and the RAB sub-flow number N comes last.

RAB sub-Flow Combination (RFC): A RAB sub-flow combination is defined as an authorised combination of the RAB sub-flows variable attributes (e.g. SDU sizes) of currently valid RAB sub-flows that can be submitted simultaneously to the Iu UP for transmission over Iu interface. Each combination is given by the CN and cannot be altered by the SRNC.

RAB sub-Flow Combination Indicator (RFCI): This indicator uniquely identifies a RAB sub-flow combination for the duration of the Iu UP peer protocol instances i.e. it is valid until the termination of the call or until a new initialisation is performed. Usage of RFCI applies only to Iu UP protocol operated in support mode for predefined SDU size.

Principles related to RFCI allocation and initialization procedure: :

1. RFCI value is present in every Iu user frame
2. In the Initialization procedure in Iu UP, the size of every RAB sub-flow SDU for each RFCI is signalled

Transparent mode:

Transparent mode is a mode for the Iu UP. In this mode the Iu UP passes the PDUs to and from the Transport Network Layer without adding new information.

Support mode:

Support mode is a mode for the Iu UP. In this mode the Iu UP adds frame control information to the PDUs before transferring them to and from the Transport Network Layer.

1.2 Symbols

For the purposes of the present document, the following symbols apply:

1.3 Abbreviations

<u>AMR:</u>	<u>Adaptive Multi-Rate codec</u>
AS:	Access Stratum
CN:	Core Network
NAS:	Non Access Stratum
<u>QoS:</u>	<u>Quality of Service</u>
PDU:	Protocol Data Unit
PCE:	Procedure Control Extension

PME: Procedure Control Bitmap Extension
RAB: Radio Access Bearer
RANAP: Radio Access Network Application Part
RFC: RAB sub Flow Combination
RFCI: RFC Indicator
RNL: Radio Network Layer
SMpSDU: Support Mode for predefined SDU size
SMvSDU: Support for variable SDU size
TNL: Transport Network Layer
TrM: Transparent Mode
UP: User Plane

3.4 Concepts

Iu UP mode of operation:

One objective of the Iu User Plane (UP) protocol is to remain independent of the CN domain (Circuit Switched or Packet Switched) and to have limited or no dependency with the Transport Network Layer. Meeting this objective provides the flexibility to evolve services regardless of the CN domain and to migrate services across CN domains.

The Iu UP protocol is therefore defined with modes of operation that can be activated on a RAB basis rather than on a CN domain basis or (tele)service basis. The Iu UP mode of operation determines if and which set of features shall be provided to meet e.g. the RAB QoS requirements.

Iu UP protocol PDU Type:

The Iu UP protocol PDU Types are defined for a given Iu UP mode of operation. An Iu UP PDU Type represents a defined structure of an Iu UP protocol frame. For instance, a frame made of a Frame Control part and a Frame Payload part would be specified as a certain PDU type valid for a given Iu UP mode of operation.

4 General

4.1 General Architectural aspects

The Iu UP protocol is located in the User plane of the Radio Network layer over the Iu interface: the Iu UP protocol layer.

The Iu UP protocol is used to convey user data associated to Radio Access Bearers.

One Iu UP protocol instance is associated to one RAB and one RAB only. If several RABs are established towards one given UE, then these RABs make use of several Iu UP protocol instances.

Iu UP protocol instances exist at Iu access point as defined [2] i.e. at CN and UTRAN. Whenever a RAB requires transfer of user data in the Iu UP, an Iu UP protocol instance exists at each Iu interface access points. These Iu UP protocol instances are established, relocated and release together with the associated RAB.

Whether these peer protocol instances perform some RAB related function depends on the mode of operation of the Iu UP as defined below.

The following figure illustrates the logical placement of the Iu -UP protocol layer and the placement of the Data Streams sources outside of the Access Stratum.

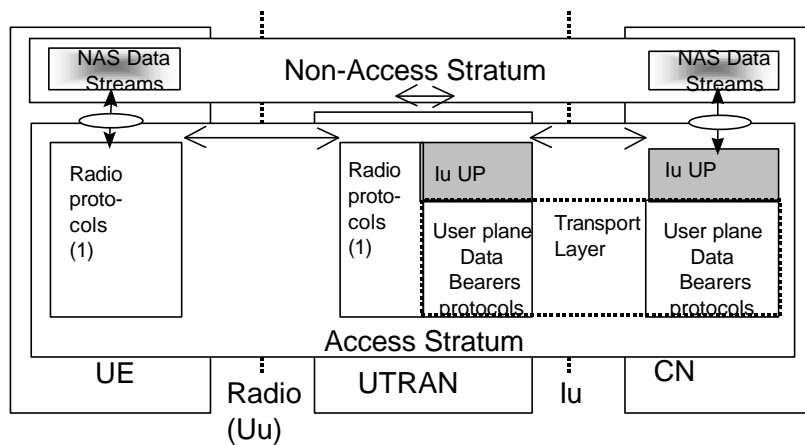

Figure 1: Iu UP protocol layer occurrence in UTRAN overall architecture (User Plane View)

4.2 Operational and Functional aspects

4.2.1 Iu UP protocol modes of operation

The Iu UP protocol operates in mode according to the concept described in earlier section.

Three modes of operation of the protocol are defined:

1. Transparent mode (TrM)
2. Support mode for predefined SDU size (SMpSDU)
3. Support mode for variable SDU size (SMvSDU)

Determination of the Iu UP protocol instance mode of operation is a CN decision taken at RAB establishment based on e.g. the RAB characteristics. It is signalled in the Radio Network layer control plane at RAB assignment and relocation for each RAB. It is internally indicated to the Iu UP protocol layer at user plane establishment.

The choice of a mode is bound to the nature of the associated RAB and cannot be changed unless the RAB is changed.

Transparent mode (TrM)

The transparent mode is intended for those RABs that do not require any particular feature from the Iu UP protocol other than transfer of user data.

The following figure illustrates the transparent mode of operation of the Iu UP protocol layer:

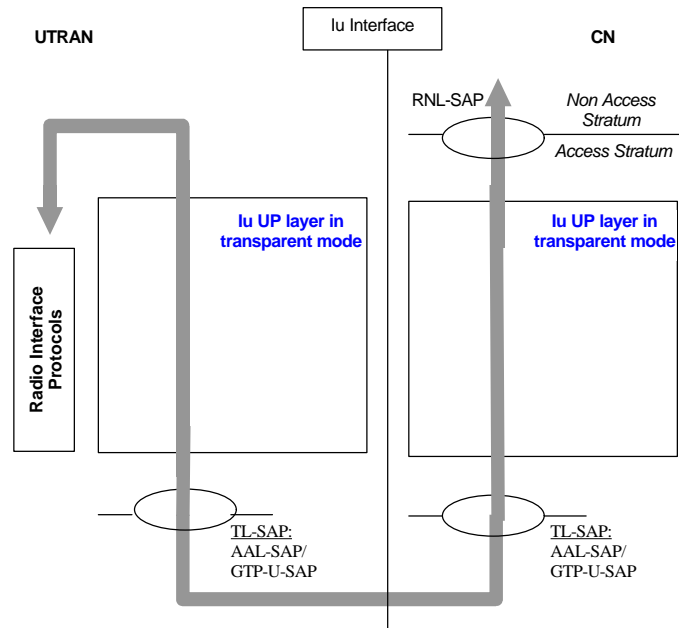

Figure 2: Iu UP protocol layer in transparent mode occurrence over Iu interface

In this mode, the Iu UP protocol instance does not perform any Iu UP protocol information exchange with its peer over the Iu interface; no Iu frame is sent. The Iu UP protocol layer is crossed through by PDUs being exchanged between upper layers and transport network layer.

For instance, the transfer of GTP-U PDUs or Transparent CS data could utilise the transparent mode of the Iu UP protocol.

4.2.3 Support modes

The support modes are intended for those RABs that do require particular features from the Iu UP protocol in addition to transfer of user data. When operating in a support mode, the peer Iu UP protocol instances exchange Iu UP frames whereas in transparent mode, no Iu UP frames are generated.

The following figure illustrates the functional model of the Iu UP protocol layer in support mode of operation:

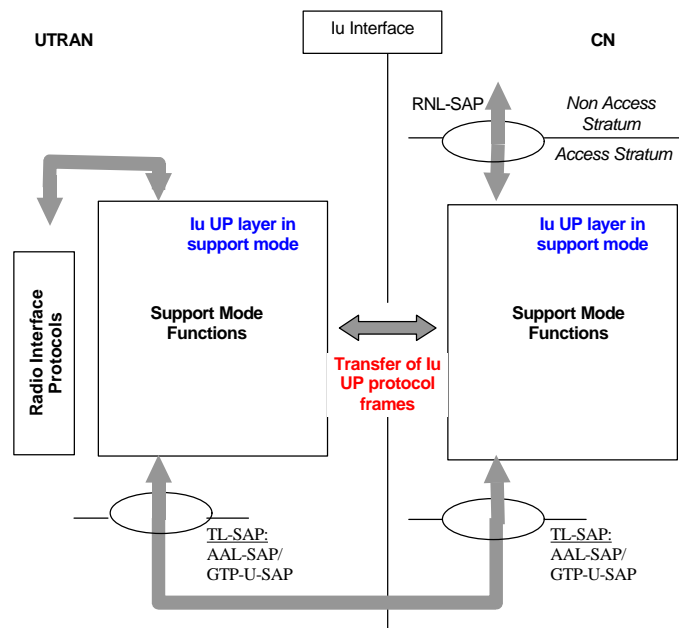

Figure 3: Iu UP protocol layer in support mode occurrence over Iu interface

Some RABs requesting Iu UP protocol support, constrain the Iu UP protocol and possibly the radio interface protocols in specific ways. For instance, certain RABs can have variable predefined rates while other RABs can have totally variable rates within a range, as signalled in the RNL control plane.

The Iu UP support and the usage of the radio interface protocols for these kinds of RABs differ significantly. Consequently, the Iu UP support mode has two variations:

1. Support mode for predefined SDU size (SMpSDU)
2. Support mode for variable SDU size (SMvSDU)

For instance, the transfer of AMR speech PDUs would utilise the support mode for predefined SDU size of the Iu UP protocol because it requires some procedure control functions and some data streams specific functions while the sizes of the user data being transferred can vary in a predefined manner.

The choice of a support mode (for predefined or variable SDU size) is bound to the nature of the associated RAB and cannot be changed unless the RAB is changed.

The following principles apply to the Iu UP protocol when operated in the support mode for predefined-size SDUs:

Principles related to RAB sub-flow numbering:

- 1) ~~RAB sub-flows are numbered from 1 to N (N is the number of sub-flows)~~
- 2) ~~RAB sub-flow number 1 corresponds to the highest reliability class and the RAB sub-flow number N corresponds to the lowest reliability class.~~

~~Note: It is FFS whether numbering of subflows can be based on something else than reliability classes.~~

- 3) ~~RAB sub-flows order inside the Iu frame is predefined so that RAB sub-flow number one comes first and the RAB sub-flow number N comes last.~~

Principles related to RFCI allocation and initialization procedure:

- 1) ~~In the Initialization procedure in Iu UP, the size of every RAB sub-flow SDU for each RFCI is signalled~~
- 2) ~~RFCI value is present in every Iu user frame~~

1 Transparent mode

1.1 General

1.1.1 Operation of the Iu UP in Transparent mode

The Iu UP layer in Transparent mode is present in the Iu User plane for transferring data transparently over the Iu interface.

The two strata communicate through a Service Access Point for Non Access Stratum (NAS) Data Streams transfer.

Interfaces of the Iu UP protocol layer in Transparent mode

The Iu UP protocol layer in Transparent Mode is an empty layer through which NAS Data Streams PDUs are crossing between the Transport Network Layer and upper layers.

Iu UP Protocol layer Services in Transparent mode

The following functions are needed to support this mode:

- Transfer of user data

Services Expected from the UP Data Transport layer

The Iu UP protocol layer in Transparent mode expects the following services from the Transport Network Layer:

- Transfer of user data

1.2 Elements for Iu UP communication in Transparent mode

1.2.1 Frames Format for transparent

The following shows the format of the PDU crossing the Iu UP protocol layer in transparent mode. This frame is transferred transparently between the Iu UP protocol upper layers and transport network layer (TL-SAP).

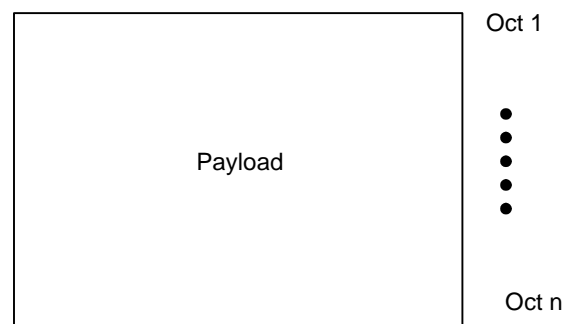

This PDU has a variable length of n octets, whose maximum range depends on the type of user data (e.g. IP packet, UDI CS data etc..). No explicit length indication is visible at the Iu UP protocol layer.

4 Support modes

6.1 General

6.1.1 Operation of the Iu UP in Support mode

The Iu UP protocol layer in Support mode is present for data streams that need frame handling in the UP.

The two strata communicate through a Service Access Point for Non Access Stratum (NAS) Data Streams. There can be one or several data streams towards one Iu -UP protocol instance. These non-access stratum data streams need to be co-ordinated in the Non-Access Stratum.

6.1.2 Interfaces of the Iu -UP protocol layer in Support mode

As part of the Access Stratum responsibility, the Iu -UP protocol layer in sSupport mode (SM) provides the services and functions that are necessary to handle non access stratum data streams. The Iu -UP protocol

layer in support mode SM is providing these services to the UP upper layers - through a Dedicated Service Access Point used for Information Transfer as specified in [54].

The Iu -UP protocol layer in support mode SM is using services of the Transport layers in order to transfer the Iu UP PDUs over the Iu interface.

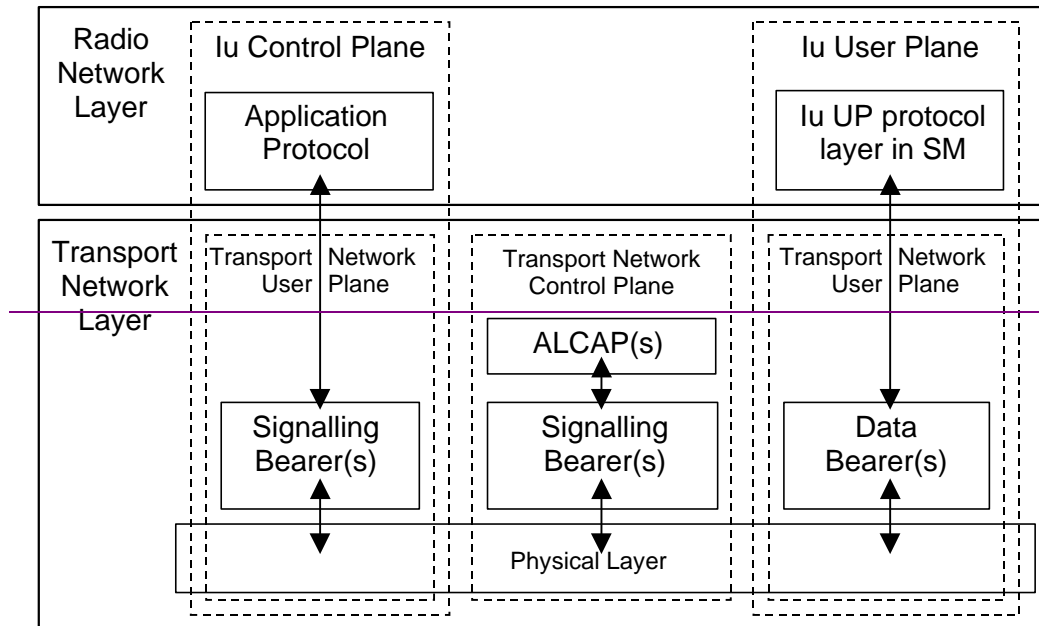

Figure 2: Iu -UP protocol layer interfaces in Support Mode

6.2 Iu -UP Protocol layer Services in Support mode

- **Support mode for predefined SDU size Service**

The following functions are needed to support this mode:

- Transfer of user data
- Initialisation
- Rate Control (FFS)
- Time Alignment (FFS)
- Handling of abnormal event

- **Support mode for variable SDU size Service**

The following functions are needed to support this mode:

- FFS

6.3 Services Expected from the UP Data Transport layer

The Iu UP protocol layer expects the following services from the Transport Network Layer:

- Transfer of user data

6.4 Functions of the lu -UP Protocol Layer in Support mode

6.4.1 Functional model of the lu UP Protocol Layer in Support mode

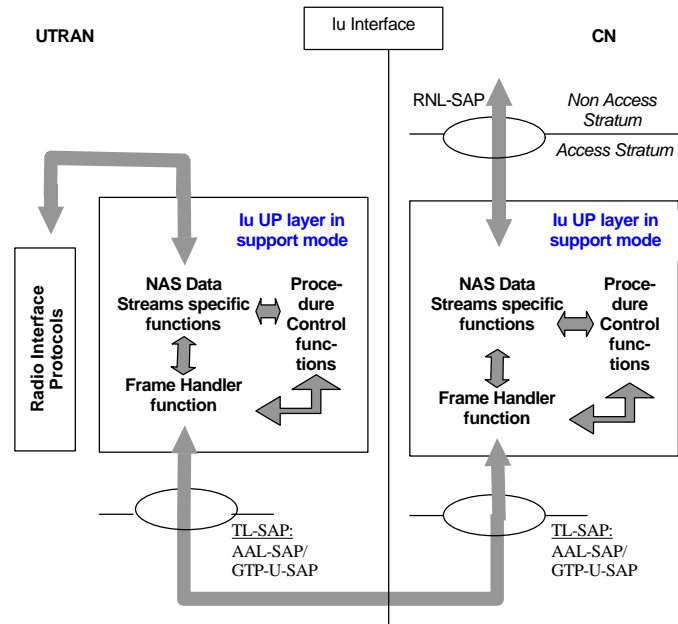

Figure 5: Functional model of the lu UP protocol layer in Support mode

The lu -UP -protocol layer in Support mode is made of three sets of a number of functions:

1. such as Frame Handler function
2. Procedure Control functions
3. Frame Handler function and Non Access Stratum Data Streams specific functions.

6.4.2 Frame Handler function

This function is responsible for framing and de-framing the different parts of an lu UP protocol frame. This function takes the different part of the lu UP protocol frame and set the control part field to the correct values. It also ensures that the frame control part is semantically correct. This function is responsible for interacting with the Transport layers. This function is also responsible for the CRC check of the lu UP frame header.

6.4.3 Procedure Control functions

This set of functions offers the control of a number of procedures handled at the lu UP- protocol level. These functions are responsible for the procedure control part of the lu -UP frames.

Namely, these procedures are:

- **Rate Control/AB Format selection (FFS):** is the procedure which controls over lu UP the maximum rate among the *RAB Formats* (to update) negotiated for the established RAB service. The function controlling this procedure interacts with functions outside of the lu- UP protocol layer.
- **Initialisation:** is the procedure which controls the exchange of initialisation information that may be required for certain RAB such as Speech. Such information can contain the RFCI/AB Format Set to be used until termination of the connection or until the next initialisation procedure.
- **Time Alignment (FFS):** is the procedure that controls the information exchanged over the lu related to the sending time of lu -UP frames. The function controlling this procedure interacts with functions outside of the lu -UP protocol layer.

- **Handling of Abnormal Event:** is the procedure that controls the information exchanged over the lu related to detection of a fault situation. The function controlling this procedure interacts with functions outside of the lu UP protocol layer.

6.4.4 Non Access Stratum Data Streams specific function(s)

These functions are responsible for a “limited” manipulation” of the payload and the consistency check of the frame number. If a frame loss is detected due a gap in the sequence of the received frame numbers, this shall be reported to the procedure control function. These functions are responsible for the CRC check and calculation of the lu UP frame payload part.

These functions interact with the upper layers through a SAP by exchanging lu data stream blocks of lu UP frame payload.

Note: The following paragraph is FFS

These functions interact with the procedure control functions ~~for handling the RAB format selection procedure data (RFN, lu Data Stream Block size, etc.)~~.

These functions ~~may~~ provide service access to the upper layers for the procedure control functions.

6.5 Elementary procedures

6.5.1 Transfer of User Data procedure

5.5.1 Initialisation procedure

Note: It is FFS whether this procedure is to be merged with a procedure used in the communication phase.

The initialisation procedure is always controlled by the entity in charge of establishing the Radio Network Layer User Plane i.e. SRNS.

The initialisation procedure is invoked whenever indicated by the lu UP Procedure Control function e.g. as a result of a relocation or at RAB establishment over lu.

This procedure is mandatory for a speech RAB.

Note: Whether this procedure can also be used for Data is FFS.

The lu -UP procedure control function allocates an indicator to each RAB sub-Flow Combination (RFCI). The association of indicators to RAB Flow Combinations is valid until a new initialisation procedure is performed or the connection is terminated.

The procedure control function may also generate additional lu UP protocol parameters necessary for the RAB service to operate properly over lu.

To each RAB sub-Flow combination indicator is associated the size of each RAB sub-Flow SDU of that cCombination-SDU size. The list of RAB Flow Combination Indicators and their respective SDU sizes constitutes the RAB sub-Flow Combination set passed over the lu -UP.

Note: It is FFS whether the SDU size of the RAB sub-Flow Combination is sent during this procedure or instead the SDU size of every RAB sub-Flow of a each RAB sub-Flow Combination.

The first RAB sub-Flow Combination proposed in the list of RAB sub-Flow Combination indicates the initial RAB sub-Flow Combination i.e. the first RAB sub-Flow Combination to be used when starting the communication phase.

The complete set of information is framed by the lu -UP Frame Handler function and transferred in an lu-UP Control (FFS)-initialisation frame.

Upon reception of an **control (FFS)** frame indicating that an initialisation control procedure is active in the peer Iu UP entity, the Iu UP protocol layer **forwards/stores** the RAB sub-Flow Combination set to be used by the Control procedure function. **It also relays to the upper layer through its RNL SAP, the indication of the initial RAB sub-Flow Combination.**

Consequently, when in the communication phase (as indicated by internal functions in the Radio Network layer), the frame transmission starts in **uplink and** downlink in the initial RAB Flow Combination.

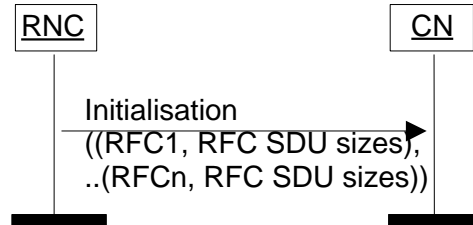

Figure x. Initialisation of Iu UP for n RFCs

Note of the editor: The need for an acknowledgement frame (and time supervision) and a repetition mechanism is FFS.

Note of the editor: The case where an SRNS receives an Iu control (FFS) frame indicating that an initialisation procedure is active at the other end of the Iu UP could be related to a TFO negotiation. How TFO protocol and codec negotiation is performed is FFS.

6.5.3 Rate Control procedure (FFS)

6.5.4 Time Alignment procedure (FFS)

6.5.5 Handling of Abnormal Event procedure

5.6 Primitives for the Support Mode

5.6.1 Primitives for the Support Mode for predefined size SDUs

5.6.1.1 Principle

The principle illustrated by the figure below is used for modelling the primitives towards the protocol layer:

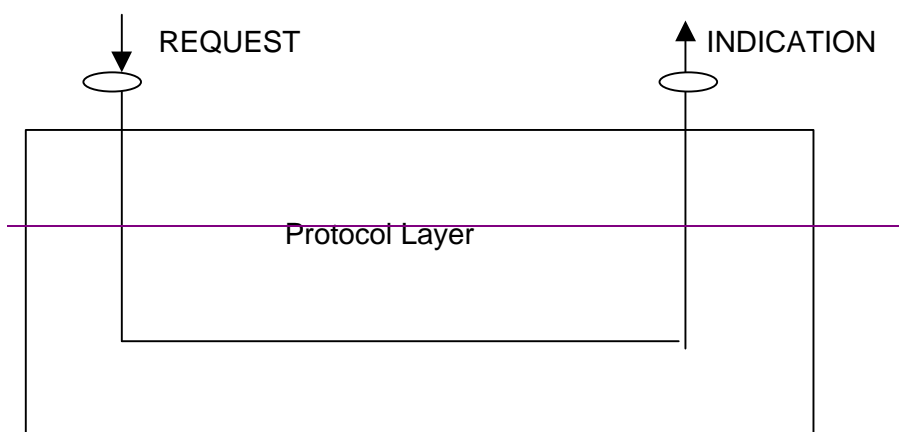

5.6.1.2 Primitives towards the upper layers at the RNL-SAP

The Iu-UP protocol layer interacts with other layers as illustrated in *figure 3 of [1]*. The interactions with the upper layers are shown in terms of primitives where the primitives represent the logical exchange of information and control between the upper layer and the Iu-CS-UP protocol layer. They do not specify or constraint implementations.

For the Iu-UP protocol layer, the following primitives are defined:

– Iu-UP-DATA

– Iu-UP-STATUS

Iu-NAS-Data-Stream-DU is a generic term referring to either speech or data stream data units.

Table 1. Iu-UP protocol layer service primitives

Primitive	Type	Parameters	Comments
Iu-UP-DATA	Request	Iu-UP-payload	
		Iu-UP-control	Abnormal Event <i>RFC request (FFS. Note 1)</i>
	Indication	Iu-UP-payload	
		Iu-UP-control	<i>RFC Request (FFS. Note 2)</i> RFC Indication Abnormal Event <i>Time Alignment (FFS Note 3)</i>
Iu-UP-Status	Indication	Iu-UP-Control	Abnormal Event Initialisation
			Request

5.6.1.3 Iu-UP-DATA-REQUEST

This primitive is used as a request from the upper layer Iu-NAS-Data-Stream entity to send a RAB-SDU on the established transport connection.

When an abnormal condition like a corrupted is detected, then this primitive includes Control Information. This primitive may also include abnormal event control information related to frame(s) sent earlier by the Iu-CS-DS peer entity.

Note 1: This information is related to maximum rate control. It is therefore FFS.

The Iu-CS-UP Frame protocol layer forms the Iu-UP data frame, the Iu-Data-Stream-DU being the payload of the Iu-UP frame, and transfers the frame by means of the lower layer services.

5.6.1.4 Iu-UP-DATA-INDICATION

This primitive is used as an indication to the upper layer entity to pass the Iu-NAS-Data-Stream-User-Plane information of a received Iu-CS-UP frame.

This primitive normally includes also the RFCI of the payload information included in the primitive. If it does not include the RFCI, this shall be interpreted as if no RAB-sub-flow-combination change occurred since the last received RFCI.

This primitive may also include a request for a RFC change. This corresponds to the case where a change of RFC needs to be applied to the frames sent in the opposite direction.

Note 2: This information is related to maximum rate control. It is therefore FFS.

This primitive may also include an abnormal event information aiming at informing the upper layers of a faulty situation that may relate to the payload included in the primitive or to frame(s) sent earlier by the Iu-CS-DS receiving entity.

Note 3: Time Alignment is FFS.

5.6.1.5 Iu-UP-STATUS

This primitive is used to report to the upper layer entity that a fault has been detected. The information concerning that fault is characterised by the Abnormal event information passed to the upper layer.

This primitive is also used in the context of the initialisation control procedure to pass to the upper Iu-CS-DS layer e.g. the initial RFC to be used in the communication phase.

Note: It is assumed here that no payload is transferred with the initialisation frame. Whether an acknowledgement frame is necessary is FFS.

5.6.1.6 Primitives towards the transport layers at the AAL-SAP

5.6.1.7 ATM/AAL2 Transport layer

When the Iu-CS-UP protocol layer uses the services of an ATM/AAL2 transport, it uses an established AAL2 connection for transferring frames between the peer CS-TL-SAPs at both end of the Iu User plane access points. The Transport Network Control Plane over Iu handles the signalling to establish and release the AAL2 call connections.

5.6.1.8 AAL2 Service Primitives used by the Iu-UP protocol

AAL2 services and primitives used at the Service Access Point from the AAL2 layer are shown in the following table:

Table 2. AAL2 primitives and parameters

Primitive	Type	Parameters	Comments
AAL-UNITDATA	Request	AAL-INFO	1-45 Octets of Iu-CS-UP protocol data
		AAL-UII	Not used (Note 1)
AAL-UNITDATA	Indication	AAL-INFO	1-45 Octets of Iu-U-CS-P protocol data
		AAL-UII	Not used (Note 1)

Note 1 The setting of this field must be defined. It is left FFS.

The primitives of Table 2 are the standard primitives of [5]. These primitives are intended to be used in the Iu-UP.

For the purpose of the Iu-CS-UP protocol, the AAL2 layer is limited to the Common Part Sublayer i.e. no Service Specific Convergence Sublayer is required.

Note of the editor: The SSCS-SAAR has not been proposed so far because it is not necessary for low bandwidth speech such as AMR. This proposal will be revisited when CS Data will be introduced in the Iu-CS-User Plane.

5.6.1.9 Primitives towards the transport layers at the GTP-U-SAP

Note: The GTP-SAP has not been defined yet. The standardisation of this SAP and related primitives should be on the responsibility of TSG-N2. A LS asking for standardisation of GTP-SAP should be send from R3 to N2.

5.6.1.10 GTP Transport Layer

When the Iu-UP protocol layer uses the services of a GTP transport, it uses an established GTP-U tunnel for transferring frames between the peer GTP-SAPs at both end of the Iu User plane access points. The RANAP Control Plane signalling over Iu handles the signalling to establish and release the GTP-U tunnels.

5.6.2 Primitives for the Support Mode for variable size SDUs

5.7.1.3 Elements for lu -UP communication in Support mode

5.7.1.3.1 Frames Format for predefined size SDUs

5.7.1.3.1.1 PDU Type 0

The following shows the lu frame structure for PDU type 0 of the lu UP protocol at the SAP towards the transport layers (TL-SAP):

PDU Type 0		Frame Number	Frame Control Part
PME	Procedure Control Bitmap		
PCE	Procedure for Initialisation Control		Frame Procedure Control Part
PCE	Procedure for XX Control		
Payload Checksum		Header Checksum	Frame CheckSum Part
Payload Fields			Frame Payload Part

Bits											
7	6	5	4	3	2	1	0				
PDU Type				Frame Number				M	4	Bytes	Frame Control Part
PME	Procedure Control Bitmap							M	2		Frame Procedure Control Part
PCE	This field is FFS RAB Format Selection Control Field							0	3		
PCE	This field is FFS Time Alignment Control Field							0	4		
PCE	Abnormal Event Control Field							0	5		
PCE	Initialization Control Field							0	6		
Frame Payload Check Sum				Frame Header Check Sum				M	7	Frame Check Sum Part	
Payload Fields								C	8-n	Frame Payload part	

Figure 4: lu- UP PDU Type 0 Format

C: Conditional
 M: Mandatory
 O: Optional

The lu UP ~~PDU Type 0 protocol frames are~~ made of four parts:

- 1) lu UP Frame Control part
- 2) lu UP Frame Procedure Control part
- 3) lu UP Frame Check Sum
- 4) lu UP Frame Payload part

The lu UP Frame Control Part, the lu UP Frame Procedure Control Part and the lu UP Frame Check Sum constitute the lu UP Frame Header.

5.7.21.3.2 Frames Format for variable size SDUs

5.7.31.3.3 Frames content definition

5.7.41.3.4 Frames coding

5.7.51.3.5 Timers

5.81.4 Handling of unknown, unforeseen and erroneous protocol data

6.2 Primitives for the Transparent Mode

6.2.1 Principle

The principle illustrated by the figure below is used for modelling the primitives towards the protocol layer:

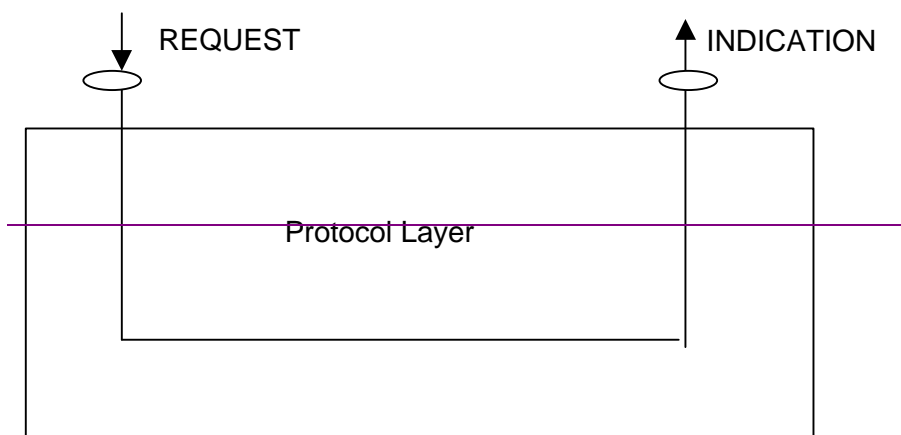

6.2.2 Primitives towards the upper layers at the RNL SAP

The Iu-UP protocol layer interacts with other layers as illustrated in *figure 3 of [1]*. The interactions with the upper layers are shown in terms of primitives where the primitives represent the logical exchange of information and control between the upper layer and the Iu-UP protocol layer. They do not specify or constraint implementations.

For the transparent mode of the Iu-UP protocol layer, the following primitive is defined:

– Iu-UP-DATA

Table 2. Iu-UP protocol layer service primitives

Primitive	Type	Parameters	Comments
Iu-UP-UNIT-DATA	Request	Iu-UP-PDU	
	Indication	Iu-UP-PDU	

6.2.2.1 Iu-UP-UNIT-DATA-REQUEST

This primitive is used as a request from the upper layer to send an Iu-UP PDU on the established transport connection in the transparent mode of operation.

The Iu-UP protocol layer transfers the Iu Data Stream DU by means of the lower layer services without adding any protocol header overhead.

6.2.2.2 Iu-UP-UNIT-DATA-INDICATION

This primitive is used as an indication to the upper layer entity to pass the Iu-UP PDU of a received Iu-UP frame in the transparent mode of operation.

6.2.3 Primitives towards the transport layers at the AAL-SAP

6.2.3.1 ATM/AAL2 Transport layer

When the Iu-UP protocol layer uses the services of an ATM/AAL2 transport, it uses an established AAL2 connection for transferring frames between the peer TNL-SAPs at both end of the Iu User plane access points. The Transport Network Control Plane over Iu handles the signalling to establish and release the AAL2 call connections.

6.2.3.2 AAL2 Service Primitives used by the Iu-UP protocol

AAL2 services and primitives used at the Service Access Point from the AAL2 layer are shown in the following table:

Table 2. AAL2 primitives and parameters

Primitive	Type	Parameters	Comments
AAL-UNITDATA	Request	AAL-INFO	1-45 Octets of Iu-UP protocol data
		AAL-UII	Not used (Note 1)
AAL-UNITDATA	Indication	AAL-INFO	1-45 Octets of Iu-UP protocol data
		AAL-UII	Not used (Note 1)

Note 1 The setting of this field must be defined. It is left FFS.

The primitives of Table 2 are the standard primitives of [5]. These primitives are intended to be used in the Iu-UP.

For the purpose of the Iu-UP protocol, the AAL2 layer is limited to the Common Part Sublayer i.e. no Service Specific Convergence Sublayer is required.

Note of the editor: The SSCS SAAR has not been proposed so far because it is not necessary for low bandwidth speech such as AMR. This proposal will be revisited when CS Data will be introduced in the Iu User Plane.

6.2.4 Primitives towards the transport layers at the GTP-SAP

Note: The GTP-SAP has not been defined yet. The standardisation of this SAP and related primitives should be on the responsibility of TSG N2. A LS asking for standardisation of GTP-SAP should be send from R3 to N2.

6.2.4.1 GTP Transport Layer

When the Iu-UP protocol layer uses the services of a GTP transport, it uses an established GTP-U tunnel for transferring frames between the peer GTP-SAPs at both end of the Iu User plane access points. The RANAP Control Plane signalling over Iu handles the signalling to establish and release the GTP-U tunnels.

Communication Primitives for the Iu UP protocol layer

Modelling Principle

The principle illustrated by the figure below is used for modelling the primitives towards the protocol layer:

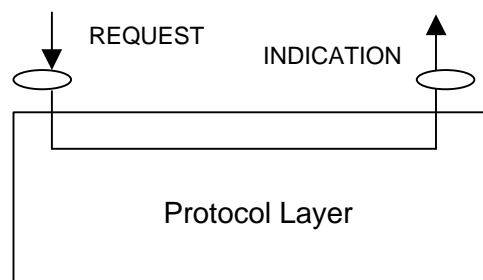

Primitives towards the upper layers at the RNL SAP

General

The Iu-UP protocol layer interacts with upper layers as illustrated in *figure XX*. The interactions with the upper layers are shown in terms of primitives where the primitives represent the logical exchange of information and control between the upper layer and the Iu-UP protocol layer. They do not specify or constraint implementations.

The following primitives are defined:

- Iu-UP-DATA
- Iu-UP-STATUS
- Iu-UP-UNIT-DATA

Table 1. Iu UP protocol layer service primitives towards the upper layer at the RNL SAP

<u>Primitive</u>	<u>Type</u>	<u>Parameters</u>	<u>Comments</u>
Iu-UP-DATA	Request	Iu-UP-payload	
		Iu-UP-control	RFCI
			RFC Request (FFS. Note 1) Abnormal Event
	Indication	Iu-UP-payload	
		Iu-UP-control	RFCI
			RFC Request (FFS. Note 2) Abnormal Event
			Time Alignment (FFS Note 3)
	Iu-UP-Status	Indication	Iu-UP-Control
			Initialisation
Request		Iu-UP-Control	Abnormal Event
Iu-UP-UNIT-DATA	Request	Iu-UP-payloadPDU	
	Indication	Iu-UP-payloadPDU	

Primitives usage is function of the mode of operation of the Iu UP protocol. The following table provides the association between Iu UP primitives towards the upper layers and the Iu UP mode of operation:

Table 2. Iu UP protocol layer service primitives related to the Iu UP mode of operation and function within the mode of operation:

<u>Primitive</u>	<u>Type</u>	<u>Mode of Operation</u>
Iu-UP-DATA	Request	SMpSDU
	Indication	SMpSDU
Iu-UP-Status	Request	SMpSDU
	Indication	SMpSDU
Iu-UP-UNIT-DATA	Request	TrM
	Indication	TrM

Iu-UP-DATA-REQUEST

This primitive is used as a request from the upper layer Iu NAS Data Stream entity to send a RAB SDU on the established transport connection.

When an abnormal condition like a corrupted is detected, then this primitive includes Control Information. This primitive may also include abnormal event control information related to frame(s) sent earlier by the Iu CS DS peer entity.

Note 1: This information is related to maximum rate control. It is therefore FFS.

The Iu UP Frame protocol layer forms the Iu UP data frame, the Iu Data Stream DU being the payload of the Iu UP frame, and transfers the frame by means of the lower layer services.

Iu-UP-DATA-INDICATION

This primitive is used as an indication to the upper layer entity to pass the Iu NAS Data Stream User Plane information of a received Iu UP frame.

This primitive normally includes also the RFCI of the payload information included in the primitive. If it does not include the RFCI, this shall be interpreted as if no RAB sub-flow combination change occurred since the last received RFCI.

This primitive may also include a request for a RFC change. This corresponds to the case where a change of RFC needs to be applied to the frames sent in the opposite direction.

Note 2: This information is related to maximum rate control. It is therefore FFS.

This primitive may also include an abnormal event information aiming at informing the upper layers of a faulty situation that may relate to the payload included in the primitive or to frame(s) sent earlier by the Iu CS DS receiving entity.

Note 3: Time Alignment is FFS.

Iu-UP-STATUS-REQUEST

Note: The usage of this primitive is to be defined.

4.4.5 Iu-UP-STATUS-INDICATION

This primitive is used to report to the upper layer entity that a fault has been detected. The information concerning that fault is characterised by the Abnormal event information passed to the upper layer.

This primitive is also used in the context of the initialisation control procedure to pass to the upper Iu DS layer e.g. the RFC set and the associated RFCIs to be used in the communication phase.

Note: It is assumed here that no payload is transferred with the initialisation frame. Whether an acknowledgement frame is necessary is FFS.

Iu-UP-UNIT-DATA-REQUEST

This primitive is used as a request from the upper layer to send an Iu UP PDU on the established transport connection in the transparent mode of operation.

The Iu UP protocol layer transfers the Iu Data Stream DU by means of the lower layer services without adding any protocol header overhead.

Iu-UP-UNIT-DATA-INDICATION

This primitive is used as an indication to the upper layer entity to pass the Iu UP PDU of a received Iu UP frame in the transparent mode of operation.

Primitives towards the transport layers

7.3.4 General

The choice of Transport network layer SAP, currently AAL-SAP or GTP-U SAP, is fixed by the Radio Network Layer control plane logic. This choice is based on the requirements placed by e.g. the RAB characteristics, the CN domain requesting the RAB establishment or other operator's choice.

Primitives at the AAL-SAP: ATM/AAL2 Transport layer

When the Iu UP protocol layer uses the services of an ATM/AAL2 transport, it uses an established AAL2 connection for transferring frames between the peer CS TL-SAPs at both end of the Iu User plane access points. The Transport Network Control Plane over Iu handles the signalling to establish and release the AAL2 call connections.

AAL2 Service Primitives used by the Iu UP protocol

AAL2 services and primitives used at the Service Access Point from the AAL2 layer are shown in the following table:

Table 2. AAL2 primitives and parameters

<u>Primitive</u>	<u>Type</u>	<u>Parameters</u>	<u>Comments</u>
AAL-UNITDATA	Request	AAL-INFO	1-45 Octets of Iu CS UP protocol data
		AAL-UUI	Not used (Note 1)
AAL-UNITDATA	Indication	AAL-INFO	1-45 Octets of Iu U-CS P protocol data
		AAL-UUI	Not used (Note 1)

Note 1 The setting of this field must be defined. It is left FFS.

The primitives of Table 2 are the standard primitives of [5]. These primitives are intended to be used in the Iu UP.

For the purpose of the Iu UP protocol, the AAL2 layer is limited to the Common Part Sublayer i.e. no Service Specific Convergence Sublayer is required.

Note of the editor: The SSCS SAAR has not been proposed so far because it is not necessary for low bandwidth speech such as AMR. This proposal will be revisited when CS Data will be introduced in the Iu User Plane.

Primitives at the GTP-U-SAP: GTP Transport Layer

Note: The GTP-U-SAP has not been defined yet. The standardisation of this SAP and related primitives should be on the responsibility of TSG N2. A LS asking for standardisation of GTP-U-SAP should be sent from R3 to N2.

When the Iu UP protocol layer uses the services of a GTP transport, it uses an established GTP-U tunnel for transferring frames between the peer GTP-U-SAPs at both end of the Iu User plane access points. The RANAP Control Plane signalling over Iu handles the signalling to establish and release the GTP-U tunnels.

42 Annex A (Normative)

83 Annex B (Informative): Illustration of usage of RFCI for AMR speech RAB.

This annex contains information related to usage of RFCIs in the context of AMR speech RAB.

The following figure illustrates the RFCI allocation and flow throughout the UTRAN.

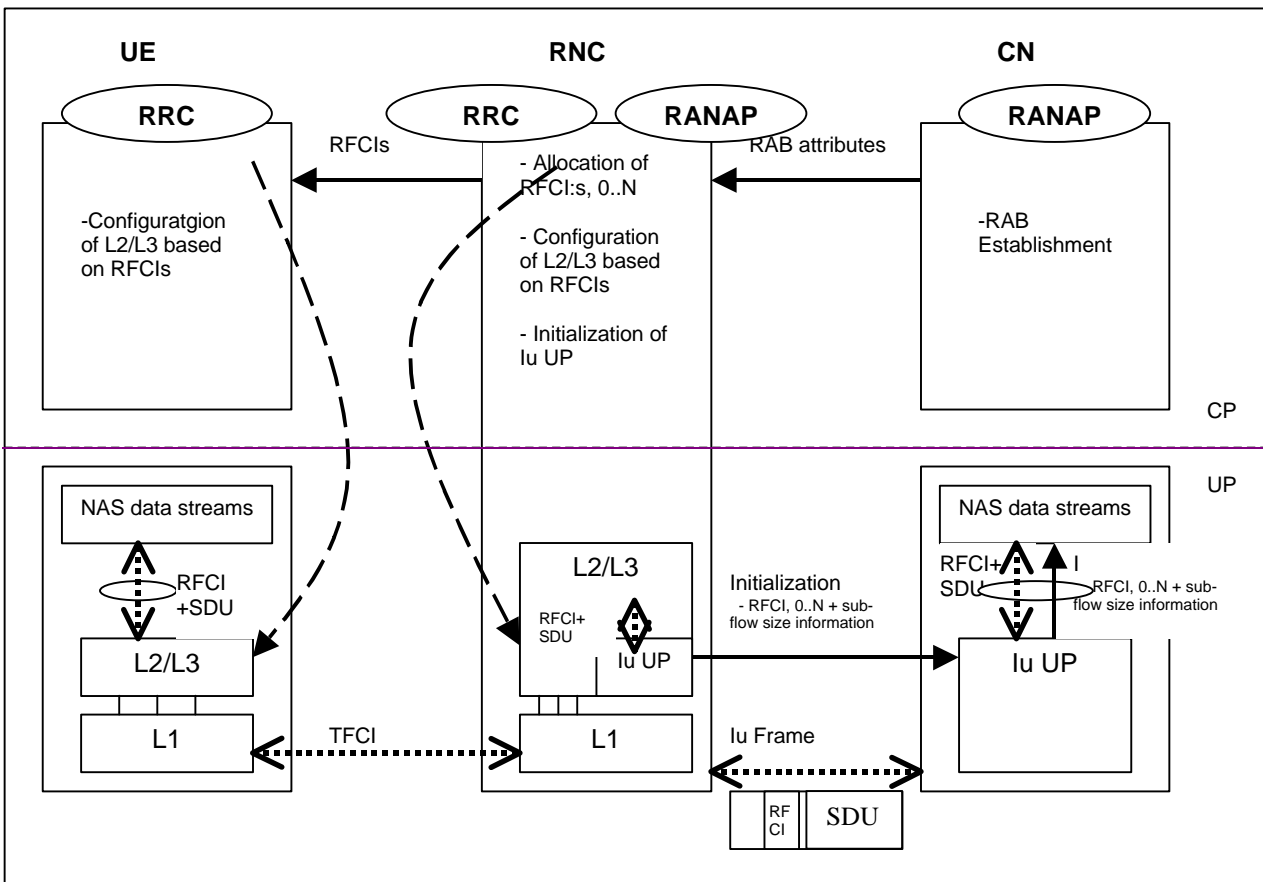

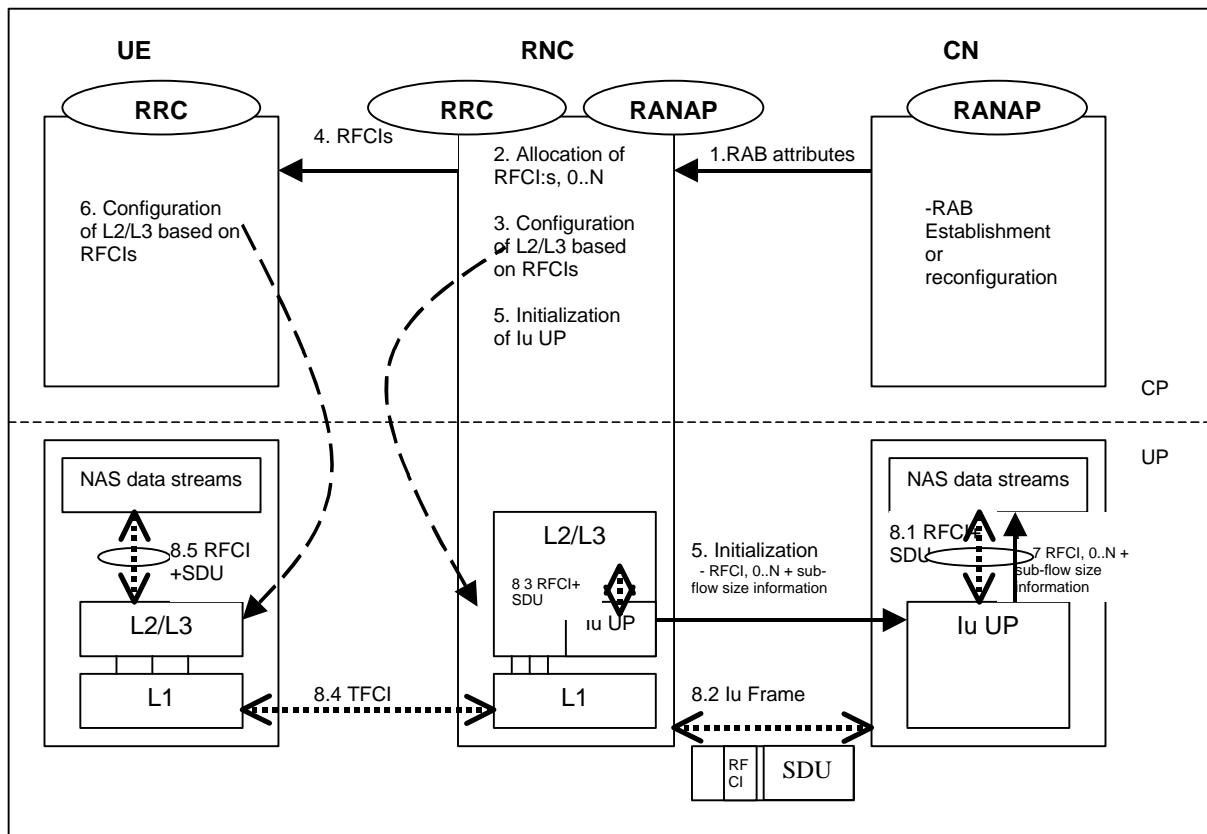

Note: The usage of RFCI in steps 4 and 8.5 is still to be agreed in RAN WG2.

1. **RAB Attributes:** at RAB establishment or reconfiguration, the SDU size information parameter is passed to UTRAN. The SDU information is organised per BER i.e. RAB sub Flow. For instance, 12.2 kbits/s AMR codec is passed as RAB sub flow 1 SDU size: 81 bits –class A bits-, RAB sub flow 2 SDU size: 108 –class B bits-, as RAB sub flow 3 SDU size: 60 –class C-, which makes one RAB sub Flow Combination. This is done for all rates (i.e. all codec modes, DTX also if included). The Iu UP is used in support mode for predefined SDU size.
2. **Allocation of RFCIs:** the RNC dynamically allocates an identification (RFCI) to each permitted/possible combinations it can offer. E.g. for 12.2. kbits/s, the RNC allocates RFCI 8 (according to the example table 1)
3. **Configuration of L2/3 based on RFCIs:** RFCIs are used to configure the L23. RLC is used transparently. MAC configures its coordinated DCHs with the RFCIs and associate one RFCI to one TFCI
4. **RFCIs:** RRC signalling is used to pass the association between the TFCI, the RFCIs and the SDU size information. RFCIs is used by the L23 to report to the Codec the received combination of SDUs over the radio transport channels
5. **Initialization of Iu UP:** the RNC reports the permitted combinations it can offer to the transcoder using an inband Iu initialisation frame containing the RFCIs and associated RAB sub Flow sizes.
6. **Configuration of L2/3 based on RFCIs:** idem as 3. L23 will use RFCI to communicate with the Codec about the RAB sub-Flow structure of the SDU received or to be sent.
7. **RFCIs+ SDU size information:** the RFCIs and associated RAB sub Flow sizes are received within the Iu initialisation frame are passed to the Codec for configuration.
8. **Example of DL frame transfer:**
 - 8.1. The Codec encodes a 12.2 kbits/s frame. It sends down to the Iu UP and SDU with an associated RFCI equals to 8 (in this example)
 - 8.2. The Iu UP packs a frame with a header containing an RFCI set to value 8, and the payload made of the SDU received from the Codec.
 - 8.3. The Iu UP passes to L23, the Iu frame payload (the Codec SDU) and the RFCI. The L23 uses this RFCI to break the Iu frame onto the coordinated DCHs corresponding to the different bits protection classes. The corresponding TFCI is selected.

- 8.4. *The radio frame is sent with the TFCI chosen by MAC*
- 8.5. *The L23 receives the SDUs on the coordinated DCHs, combined them back and uses the TFCI to set the RFCI to the correct value (i.e. 8 in this example). The RFCI and the L23 SDU is passed up to the codec, which decodes according to the RFCI the 12.2 kbits/s encoded speech frame.*

The following table shows RAB sub-flow SDU sizes for a RAB with variable source rate as they are signalled in RAB assignment request in RANAP.

Table 1: Example of SDU sizes for AMR with DTX

RAB sub-flows			Total size of bits/RAB sub-flows combination	Source rate
RAB sub-flow 1	RAB sub-Flow 2	RAB sub-Flow 3		
39	56	0	95	Source rate 1
49	54	0	103	Source rate 2
55	63	0	118	Source rate 3
55	79	0	134	Source rate 4
61	87	0	148	Source rate 5
75	84	0	159	Source rate 6
65	99	40	204	Source rate 7
81	103	60	244	Source rate 8
39	0	0	39	Source rate 9
⋮	⋮	⋮	⋮	⋮
0	0	0	0	Source rate M

NOTE 1: In the table above the grayed area shows what is signalled in RANAP RAB establishment request.

NOTE 2: In the table above the number of sub-flows is informative only.

SRNC allocates one or more possible/available RAB sub-flow combination(s) and generates RAB sub-flow combination set. RAB sub-flow combination number is dynamically generated by SRNC. This RAB sub-flow combination set is signalled towards CN with user plane signalling as described in [1]. The signalling towards UE is to be defined by TSG-RAN WG2.

RAB sub-flow combination set

A RAB sub-flow combination indicator, RFCI, indicates which RAB sub flow combination will be used for the Iu user frames. In the communication phase the RFCI is included in the user frame, and the RFCI state the structure of the user frame.

Table 2 below exemplifies the allocation of 4 different RAB sub-flows combinations for 3 sub-flows and generating of RAB sub-flows combination set.

Table 2: Example of Allocation of RAB sub-flows combination indicator

	RFCI (RAB sub-Flow Combination Indicator)	RAB sub- flow 1	RAB sub- flow 2	RAB sub- flow 3	Total	Source rate
RAB sub- flows combin ation set	0	0	0	0	0	Source rate 1
	1	39	0	0	39	Source rate 2
	2	39	56	0	95	Source rate 3
	3	81	103	60	244	Source rate 4

NOTE: In the table above the grayed area shows the part that is sent in the initialization procedure in Iu UP. This is what constitutes the RAB subflow combination set.

94 Annex C (Informative) Document Stability Assessment Table

Section	Content missing	Incomplete	Restructuring needed	Checking needed	Editorial work required	Finalisation needed	Almost stable	Stable
1		√		√				
2		√		√				
3		√		√				
4		√	√	√	√			
5		√	√	√	√			
6		√		√	√			
7		√		√				
8				√				
9				√	√			

105 History

Document history		
Edition x		Publication

0.0.1	Feb 1999	First draft
0.0.2	March 1999	Revised following RAN WG3#2 meeting: <ul style="list-style-type: none"> - TSG SA S2-99080: Iu UP instances - TSG RAN WG3#2 R3-99195
0.1.0	April 1999	Prepared for the RAN WG#3 meeting. <ul style="list-style-type: none"> - Document noted TSG SA S2-99080: Iu UP instances
0.1.1	May 1999	Revised following RAN WG3#3 meeting <ul style="list-style-type: none"> - Editorial additions: abbreviations, corrected references - TSG R3 (99) 281: incorporation of the proposals, inclusion of the frame format, RAB Format Selection and Time Alignment FFS - TSG R3 (99) 368: alignment of the 281 proposals with the co ordinated data streams concepts of 368. - Inclusion of detailed comments of the Iu SWG on TSG R3 (99) 281 - Note: - <i>TSG R3 (99) 257: provisions for load sharing on Iu between RNC and CN PS, moved to 25.414</i> - <i>TSG R3 (99) 276: incorporation of the two parts of proposal 1 (i.e. resulting in creation of appendix A): moved to 25.414</i>
0.1.2	May 1999	Revised by editor according to WG3#3 closing plenary meeting recommendations <ul style="list-style-type: none"> -Include Appendix A -Include Section 3.4.: Specification status
0.1.3	June 1999	Revised following RAN WG3#4 meeting. <ul style="list-style-type: none"> - Removal of the temporary appendix containing the GTP-U agreed proposal <i>TSG R3 (99) 276. Proposed in Liaison TSGR3#4 (99) 569</i> - Move the specification status table to Annex B. Align layout with 25.401 editors proposal - Include TSGR3-99458, TSG R3-99459 - Add reference to AAL2 ITU specifications
0.1.4	June 1999	<ul style="list-style-type: none">- Transparent/ Support mode
0.2.0	July 1999	<ul style="list-style-type: none">- Approved version with comments proposed in R3-99593
0.2.1	July 1999	<ul style="list-style-type: none"> - Introduction of Mode concept: R3-99717 - R3-99718: Changes to 25.415 due to mode concept - R3-99719: Modelling of primitives for the Iu UP layer - R3-99724: Principles related to RAB sub flows - R3-99786, Summary of Iu SWG
Rapporteur for 3GPP RAN 25.415 is:		

Alain G. Maupin
Ericsson Radio Systems

Tel. : +46 8 404 4379

Fax : +46 8 404 3597

Email : alain.maupin@era.ericsson.se

This document is written in Microsoft Word version 7. 0/97.