

TSG-RAN Working Group 1 meeting #11
San Diego, CA, USA
February 29 –March 3, 2000

TSGR1#11(00)0450

Agenda item:

Source: Ericsson

Title: CR 25.211-034r1: Editorial updates to 25.211

Document for: Decision

This contribution proposes a number of editorial updates to 25.211.

| | | |
|------------------------------------------------------------------|--------------------------------------------------|---------------------------------------------------------------------------------------------------------------------------------|
| <h2 style="margin: 0;">CHANGE REQUEST</h2> | | <small>Please see embedded help file at the bottom of this page for instructions on how to fill in this form correctly.</small> |
| 25.211 | CR | 034r1 |
| <small>GSM (AA.BB) or 3G (AA.BBB) specification number ↑</small> | | <small>↑ CR number as allocated by MCC support team</small> |
| For submission to: TSG-RAN #7 | for approval <input checked="" type="checkbox"/> | strategic <input type="checkbox"/> (for SMG use only) |
| <small>list expected approval meeting # here ↑</small> | for information <input type="checkbox"/> | non-strategic <input type="checkbox"/> |
| Current Version: 3.1.0 | | |

Form: CR cover sheet, version 2 for 3GPP and SMG The latest version of this form is available from: <ftp://ftp.3gpp.org/Information/CR-Form-v2.doc>

Proposed change affects: (U)SIM ME UTRAN / Radio Core Network
(at least one should be marked with an X)

Source: Ericsson **Date:** 2000-02-21

Subject: Editorial updates to 25.211

Work item: _____

| | | | |
|------------------|----------------------------------------------------------------------------------------------------------------------------------------------------------------------------------------------------------------------------------------------------------------------------------------------------------|-----------------|------------------------------------------------------------------------------------------------------------------------------------------------------------------------------------------------------------------------------------------------|
| Category: | F Correction <input type="checkbox"/> A Corresponds to a correction in an earlier release <input type="checkbox"/> B Addition of feature <input type="checkbox"/> C Functional modification of feature <input type="checkbox"/> D Editorial modification <input checked="" type="checkbox"/> | Release: | Phase 2 <input type="checkbox"/> Release 96 <input type="checkbox"/> Release 97 <input type="checkbox"/> Release 98 <input type="checkbox"/> Release 99 <input checked="" type="checkbox"/> Release 00 <input type="checkbox"/> |
|------------------|----------------------------------------------------------------------------------------------------------------------------------------------------------------------------------------------------------------------------------------------------------------------------------------------------------|-----------------|------------------------------------------------------------------------------------------------------------------------------------------------------------------------------------------------------------------------------------------------|

(only one category shall be marked with an X)

Reason for change: _____

Clauses affected: Many

| | | |
|------------------------------|-----------------------------------------------------------------------------------------------------------------------------------------------------------------------------------------------------------------------------------------------------------------------|----------------------------------------------------------------------------------------------------------------------|
| Other specs affected: | Other 3G core specifications <input type="checkbox"/> Other GSM core specifications <input type="checkbox"/> MS test specifications <input type="checkbox"/> BSS test specifications <input type="checkbox"/> O&M specifications <input type="checkbox"/> | → List of CRs: _____ → List of CRs: _____ → List of CRs: _____ → List of CRs: _____ → List of CRs: _____ |
|------------------------------|-----------------------------------------------------------------------------------------------------------------------------------------------------------------------------------------------------------------------------------------------------------------------|----------------------------------------------------------------------------------------------------------------------|

Other comments: _____

Foreword

This Technical Specification has been produced by the 3GPP.

The contents of the present document are subject to continuing work within the TSG and may change following formal TSG approval. Should the TSG modify the contents of this TS, it will be re-released by the TSG with an identifying change of release date and an increase in version number as follows:

Version 3.y.z

where:

- x the first digit:
 - 1 presented to TSG for information;
 - 2 presented to TSG for approval;
 - 3 Indicates TSG approved document under change control.
- y the second digit is incremented for all changes of substance, i.e. technical enhancements, corrections, updates, etc.
- z the third digit is incremented when editorial only changes have been incorporated in the specification;

4 Transport channels

Transport channels are the services offered by Layer 1 to the higher layers. General concepts about transport channels are described in [12].

A transport channel is defined by how and with what characteristics data is transferred over the air interface. A general classification of transport channels is into two groups:

- Dedicated [Echannels, using inherent addressing of UE](#)
- Common [Echannels, using explicit addressing of UE if addressing is needed](#)

4.1 Dedicated transport channels

There exists only one type of dedicated transport channel, the Dedicated Channel (DCH).

4.1.1 DCH – Dedicated Channel

The Dedicated Channel (DCH) is a downlink or uplink transport channel. The DCH is transmitted over the entire cell or over only a part of the cell using [e.g.](#) beam-forming antennas. ~~The Dedicated Channel (DCH) is characterized by the possibility of fast rate change (every 10ms), fast power control and inherent addressing of UEs.~~

4.2 Common transport channels

There are six types of common transport channels: BCH, FACH, PCH, RACH, CPCH and DSCH.

4.2.1 BCH – Broadcast Channel

The Broadcast Channel (BCH) is a downlink transport channel that is used to broadcast system- and cell-specific information. The BCH is always transmitted over the entire cell [and has a single transport format with a low fixed bit rate.](#)

4.2.2 FACH – Forward Access Channel

The Forward Access Channel (FACH) is a downlink transport channel. The FACH is transmitted over the entire cell or over only a part of the cell using [e.g.](#) beam-forming antennas. The FACH [can be transmitted using](#) slow power control.

4.2.3 PCH – Paging Channel

The Paging Channel (PCH) is a downlink transport channel. The PCH is always transmitted over the entire cell. The transmission of the PCH is associated with the transmission of ~~a physical-layer~~ [generated signal, the](#) Paging Indicators, to support efficient sleep-mode procedures.

4.2.4 RACH – Random Access Channel

The Random Access Channel (RACH) is an uplink transport channel. The RACH is always received from the entire cell. The RACH is characterized by ~~a limited size data field,~~ a collision risk and by [being transmitted](#) ~~the~~ [use of](#) open loop power control.

4.2.5 CPCH – Common Packet Channel

The Common Packet Channel (CPCH) is an uplink transport channel. ~~The CPCH is a contention based random access channel used for transmission of bursty data traffic.~~ CPCH is associated with a dedicated channel on the downlink which provides power control for the uplink CPCH. The CPCH is characterised by initial collision risk and by being transmitted using inner loop power control.

4.2.6 DSCH – Downlink Shared Channel

The Downlink Shared Channel (DSCH) is a downlink transport channel shared by several UEs. The DSCH is associated with one or several downlink DCH. The DSCH is transmitted over the entire cell or over only a part of the cell using e.g. beam-forming antennas.

5 Physical channels

Physical channels typically consist of a layered structure of radio frames and time slots, although this is not true for all physical channels. Depending on the channel bitsymbol rate of the physical channel, the configuration of radio frames or time slots varies.

Radio frame: A Radio frame is a processing unit which consists of 15 time slots. The length of a radio frame corresponds to 38400 chips.

Time slot: A Time slot is a unit which consists of fields containing bits. The length of a slot corresponds to 2560 chips. The number of bits per time slot may be different for different physical channels and may, in some cases, vary in time depends ~~on the physical channel.~~

5.1 The physical resource

The basic physical resource is the code/frequency plane. In addition, on the uplink, different information streams may be transmitted on the I and Q branch. Consequently, a physical channel corresponds to a specific carrier frequency, code, and, on the uplink, relative phase (0 or $\pi/2$).

5.2 Uplink physical channels

5.2.1 Dedicated uplink physical channels

There are two types of uplink dedicated physical channels, the uplink Dedicated Physical Data Channel (uplink DPDCH) and the uplink Dedicated Physical Control Channel (uplink DPCCH).

The DPDCH and the DPCCH are I/Q code multiplexed within each radio frame (see [4]).

The uplink DPDCH is used to carry the DCH transport channel ~~dedicated data generated at Layer 2 and above, i.e. the dedicated transport channel (DCH).~~ There may be zero, one, or several uplink DPDCHs on each radio link ~~Layer 1 connection.~~

The uplink DPCCH is used to carry control information generated at Layer 1. The Layer 1 control information consists of known pilot bits to support channel estimation for coherent detection, transmit power-control (TPC) commands, feedback information (FBI), and an optional transport-format combination indicator (TFCI). The transport-format combination indicator informs the receiver about the instantaneous transport format combination parameters of the different transport channels mapped to multiplexed on the simultaneously transmitted uplink DPDCH radio frame, and corresponds to the data transmitted in the same frame. ~~It is the UTRAN that determines if a TFCI should be transmitted, hence making it mandatory for all UEs to support the use of TFCI in the uplink.~~ There is one and only one uplink DPCCH on each radio link ~~Layer 1 connection.~~

Figure 1 shows the frame structure of the uplink dedicated physical channels. Each radio frame of length 10 ms is split into 15 slots, each of length $T_{\text{slot}} = 2560$ chips, corresponding to one power-control period.

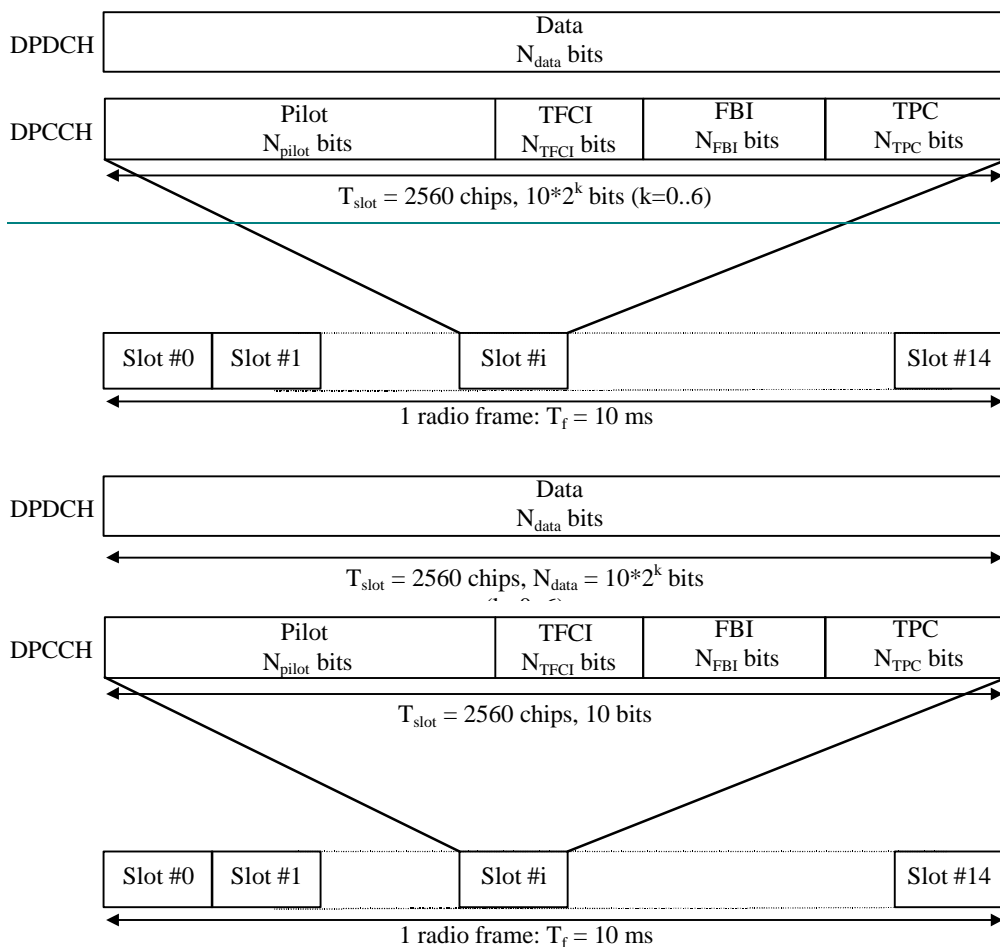

Figure 1: Frame structure for uplink DPDCH/DPCCH

The parameter k in figure 1 determines the number of bits per uplink DPDCH/DPCCH slot. It is related to the spreading factor SF of the DPDCH physical channel as $SF = 256/2^k$. The DPDCH spreading factor may thus range from 256 down to 4. Note that an uplink DPDCH and uplink DPCCH on the same Layer 1 connection generally are of different rates, i.e. have different spreading factors and different values of k . The spreading factor of the uplink DPCCH is always equal to 256, i.e. there are 10 bits per uplink DPCCH slot.

The exact number of bits of the uplink DPDCH and the different uplink DPCCH fields (N_{pilot} , N_{TFCI} , N_{FBI} , and N_{TPC}) is given by determined in table 1 and table 2. What slot format to use is configured by higher layers. The field order and total number of bits/slot are fixed, though the number of bits per field may vary during a connection.

The values for the number of bits per field are given in table 1 and table 2. The channel bit and symbol rates given in table 1 and table 2 are the rates immediately before spreading. The pilot patterns are given in table 3 and table 4, the TPC bit pattern is given in table 5.

The N_{FBI} bits are used to support techniques requiring feedback from between the UE toward the UTRAN Access Point (=cell transceiver), including closed loop mode transmit diversity and site selection diversity transmission (SSDT). The structure exact details of the FBI field is are shown in figure 2 and described below.

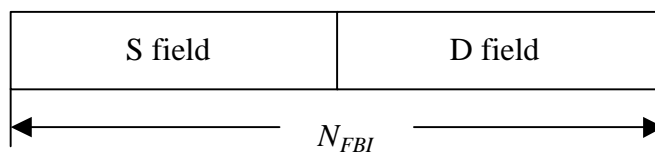

Figure 2: Details of FBI field

The S field is used for SSST signalling, while the D field is used for ~~C~~losed ~~L~~oop ~~m~~Mode ~~t~~ransmit ~~d~~iversity signalling. The S field ~~consists~~an be of length 0, 1 or 2 bits. The D field ~~consists~~an be of length 0 or 1 bit. The total FBI field size N_{FBI} is ~~given by~~according to table 2 (~~DPCCH~~ fields). Simultaneous use of SSST power control and ~~C~~losed ~~L~~oop ~~m~~Mode ~~t~~ransmit ~~d~~iversity requires that the S field ~~consists~~ of length 1 bit. The use of these FBI fields is described in ~~detail in~~ [5].

Table 1: DPDCH fields

| Slot Format #i | Channel Bit Rate (kbps) | Channel Symbol Rate (ksps) | SF | Bits/Frame | Bits/Slot | N_{data} |
|----------------|-------------------------|----------------------------|-----|------------|-----------|-------------------|
| 0 | 15 | 15 | 256 | 150 | 10 | 10 |
| 1 | 30 | 30 | 128 | 300 | 20 | 20 |
| 2 | 60 | 60 | 64 | 600 | 40 | 40 |
| 3 | 120 | 120 | 32 | 1200 | 80 | 80 |
| 4 | 240 | 240 | 16 | 2400 | 160 | 160 |
| 5 | 480 | 480 | 8 | 4800 | 320 | 320 |
| 6 | 960 | 960 | 4 | 9600 | 640 | 640 |

There are two types of ~~U~~plink ~~D~~edicated ~~P~~hysical ~~C~~hannels; those that include TFCI (e.g. for several simultaneous services) and those that do not include TFCI (e.g. for fixed-rate services). These types are reflected by the duplicated rows of table 2. ~~It is the UTRAN that determines if a TFCI should be transmitted and it is mandatory for all UEs to support the use of TFCI in the uplink. The mapping of TFCI bits onto slots is described in [3].~~

In compressed mode, DPCCH slot formats with TFCI fields are changed. There are two possible compressed slot formats for each normal slot format. They are labelled A and B and the selection between them is dependent on the number of slots that are transmitted in each frame in compressed mode. ~~The channel bit and symbol rates given in table 2 are the rates immediately before spreading.~~

Table 2: DPCCH fields

| Slot Format #i | Channel Bit Rate (kbps) | Channel Symbol Rate (ksps) | SF | Bits/Frame | Bits/Slot | N_{pilot} | N_{TPC} | N_{TFCI} | N_{FBI} | Transmitted slots per radio frame |
|----------------|-------------------------|----------------------------|-----|------------|-----------|--------------------|------------------|-------------------|------------------|-----------------------------------|
| 0 | 15 | 15 | 256 | 150 | 10 | 6 | 2 | 2 | 0 | 15 |
| 0A | 15 | 15 | 256 | 150 | 10 | 5 | 2 | 3 | 0 | 10-14 |
| 0B | 15 | 15 | 256 | 150 | 10 | 4 | 2 | 4 | 0 | 8-9 |
| 1 | 15 | 15 | 256 | 150 | 10 | 8 | 2 | 0 | 0 | 8-15 |
| 2 | 15 | 15 | 256 | 150 | 10 | 5 | 2 | 2 | 1 | 15 |
| 2A | 15 | 15 | 256 | 150 | 10 | 4 | 2 | 3 | 1 | 10-14 |
| 2B | 15 | 15 | 256 | 150 | 10 | 3 | 2 | 4 | 1 | 8-9 |
| 3 | 15 | 15 | 256 | 150 | 10 | 7 | 2 | 0 | 1 | 8-15 |
| 4 | 15 | 15 | 256 | 150 | 10 | 6 | 2 | 0 | 2 | 8-15 |
| 5 | 15 | 15 | 256 | 150 | 10 | 5 | 1 | 2 | 2 | 15 |
| 5A | 15 | 15 | 256 | 150 | 10 | 4 | 1 | 3 | 2 | 10-14 |
| 5B | 15 | 15 | 256 | 150 | 10 | 3 | 1 | 4 | 2 | 8-9 |

The pilot bit pattern is described in table 3 and table 4. The shadowed part can be used as frame synchronization words. (The value of the pilot bit other than the frame synchronization word shall be "1".)

Table 3: Pilot bit patterns for uplink DPCCH with $N_{\text{pilot}} = 3, 4, 5$ and 6

| Bit # | $N_{\text{pilot}} = 3$ | | | $N_{\text{pilot}} = 4$ | | | | $N_{\text{pilot}} = 5$ | | | | | $N_{\text{pilot}} = 6$ | | | | | |
|---------|------------------------|---|---|------------------------|---|---|---|------------------------|---|---|---|---|------------------------|---|---|---|---|---|
| | 0 | 1 | 2 | 0 | 1 | 2 | 3 | 0 | 1 | 2 | 3 | 4 | 0 | 1 | 2 | 3 | 4 | 5 |
| Slot #0 | 1 | 1 | 1 | 1 | 1 | 1 | 1 | 1 | 1 | 1 | 1 | 0 | 1 | 1 | 1 | 1 | 1 | 0 |
| 1 | 0 | 0 | 1 | 1 | 0 | 0 | 1 | 0 | 0 | 1 | 1 | 0 | 1 | 0 | 0 | 1 | 1 | 0 |
| 2 | 0 | 1 | 1 | 1 | 0 | 1 | 1 | 0 | 1 | 1 | 0 | 1 | 1 | 0 | 1 | 1 | 0 | 1 |
| 3 | 0 | 0 | 1 | 1 | 0 | 0 | 1 | 0 | 0 | 1 | 0 | 0 | 1 | 0 | 0 | 1 | 0 | 0 |
| 4 | 1 | 0 | 1 | 1 | 1 | 0 | 1 | 1 | 0 | 1 | 0 | 1 | 1 | 1 | 0 | 1 | 0 | 1 |
| 5 | 1 | 1 | 1 | 1 | 1 | 1 | 1 | 1 | 1 | 1 | 1 | 0 | 1 | 1 | 1 | 1 | 1 | 0 |
| 6 | 1 | 1 | 1 | 1 | 1 | 1 | 1 | 1 | 1 | 1 | 0 | 0 | 1 | 1 | 1 | 1 | 0 | 0 |
| 7 | 1 | 0 | 1 | 1 | 1 | 0 | 1 | 1 | 0 | 1 | 0 | 0 | 1 | 1 | 0 | 1 | 0 | 0 |
| 8 | 0 | 1 | 1 | 1 | 0 | 1 | 1 | 0 | 1 | 1 | 1 | 0 | 1 | 0 | 1 | 1 | 1 | 0 |
| 9 | 1 | 1 | 1 | 1 | 1 | 1 | 1 | 1 | 1 | 1 | 1 | 1 | 1 | 1 | 1 | 1 | 1 | 1 |
| 10 | 0 | 1 | 1 | 1 | 0 | 1 | 1 | 0 | 1 | 1 | 0 | 1 | 1 | 0 | 1 | 1 | 0 | 1 |
| 11 | 1 | 0 | 1 | 1 | 1 | 0 | 1 | 1 | 0 | 1 | 1 | 1 | 1 | 1 | 0 | 1 | 1 | 1 |
| 12 | 1 | 0 | 1 | 1 | 1 | 0 | 1 | 1 | 0 | 1 | 0 | 0 | 1 | 1 | 0 | 1 | 0 | 0 |
| 13 | 0 | 0 | 1 | 1 | 0 | 0 | 1 | 0 | 0 | 1 | 1 | 1 | 1 | 0 | 0 | 1 | 1 | 1 |
| 14 | 0 | 0 | 1 | 1 | 0 | 0 | 1 | 0 | 0 | 1 | 1 | 1 | 1 | 0 | 0 | 1 | 1 | 1 |

Table 4: Pilot bit patterns for uplink DPCCH with $N_{\text{pilot}} = 7$ and 8

| Bit # | $N_{\text{pilot}} = 7$ | | | | | | | $N_{\text{pilot}} = 8$ | | | | | | | |
|---------|------------------------|---|---|---|---|---|---|------------------------|---|---|---|---|---|---|---|
| | 0 | 1 | 2 | 3 | 4 | 5 | 6 | 0 | 1 | 2 | 3 | 4 | 5 | 6 | 7 |
| Slot #0 | 1 | 1 | 1 | 1 | 1 | 0 | 1 | 1 | 1 | 1 | 1 | 1 | 1 | 1 | 0 |
| 1 | 1 | 0 | 0 | 1 | 1 | 0 | 1 | 1 | 0 | 1 | 0 | 1 | 1 | 1 | 0 |
| 2 | 1 | 0 | 1 | 1 | 0 | 1 | 1 | 1 | 0 | 1 | 1 | 1 | 0 | 1 | 1 |
| 3 | 1 | 0 | 0 | 1 | 0 | 0 | 1 | 1 | 0 | 1 | 0 | 1 | 0 | 1 | 0 |
| 4 | 1 | 1 | 0 | 1 | 0 | 1 | 1 | 1 | 1 | 1 | 0 | 1 | 0 | 1 | 1 |
| 5 | 1 | 1 | 1 | 1 | 1 | 0 | 1 | 1 | 1 | 1 | 1 | 1 | 1 | 1 | 0 |
| 6 | 1 | 1 | 1 | 1 | 0 | 0 | 1 | 1 | 1 | 1 | 1 | 1 | 0 | 1 | 0 |
| 7 | 1 | 1 | 0 | 1 | 0 | 0 | 1 | 1 | 1 | 1 | 0 | 1 | 0 | 1 | 0 |
| 8 | 1 | 0 | 1 | 1 | 1 | 0 | 1 | 1 | 0 | 1 | 1 | 1 | 1 | 1 | 0 |
| 9 | 1 | 1 | 1 | 1 | 1 | 1 | 1 | 1 | 1 | 1 | 1 | 1 | 1 | 1 | 1 |
| 10 | 1 | 0 | 1 | 1 | 0 | 1 | 1 | 1 | 0 | 1 | 1 | 1 | 0 | 1 | 1 |
| 11 | 1 | 1 | 0 | 1 | 1 | 1 | 1 | 1 | 1 | 1 | 0 | 1 | 1 | 1 | 1 |
| 12 | 1 | 1 | 0 | 1 | 0 | 0 | 1 | 1 | 1 | 1 | 0 | 1 | 0 | 1 | 0 |
| 13 | 1 | 0 | 0 | 1 | 1 | 1 | 1 | 1 | 0 | 1 | 0 | 1 | 1 | 1 | 1 |
| 14 | 1 | 0 | 0 | 1 | 1 | 1 | 1 | 1 | 0 | 1 | 0 | 1 | 1 | 1 | 1 |

The relationship between the TPC bit pattern and transmitter power control command is presented in table 5.

Table 5: TPC Bit Pattern

| TPC Bit Pattern | | Transmitter power control command |
|----------------------|----------------------|-----------------------------------|
| $N_{\text{TPC}} = 1$ | $N_{\text{TPC}} = 2$ | |
| 1 | 11 | 1 |
| 0 | 00 | 0 |

For slot formats using TFCI, the TFCI value in each radio frame corresponds to a certain combination of bit rates of the DCHs currently in use. This correspondence is (re-)negotiated at each DCH addition/removal. The mapping of the TFCI bits onto slots is described in [3].

Multi-code operation is possible for the uplink dedicated physical channels. When multi-code transmission is used, several parallel DPDCH are transmitted using different channelization codes, see [4]. However, there is only one DPCCH per radio link connection.

5.2.2 Common uplink physical channels

5.2.2.1 Physical Random Access Channel (PRACH)

The Physical Random Access Channel (PRACH) is used to carry the RACH.

5.2.2.1.1 Overall structure of random-access RACH transmission

The random-access transmission is based on a Slotted ALOHA approach with fast acquisition indication. The UE can start the random-access transmission at the beginning of a number of well-defined time intervals—offsets, denoted *access slots*. There are 15 access slots per two frames and they are spaced 5120 chips apart, see figure 3. The timing information of the access slots and the acquisition indication is described given in section 7.3. Figure 3 shows the access slot numbers and their spacing to each other. Information on what access slots are available for random-access transmission in the current cell is given by higher layers.

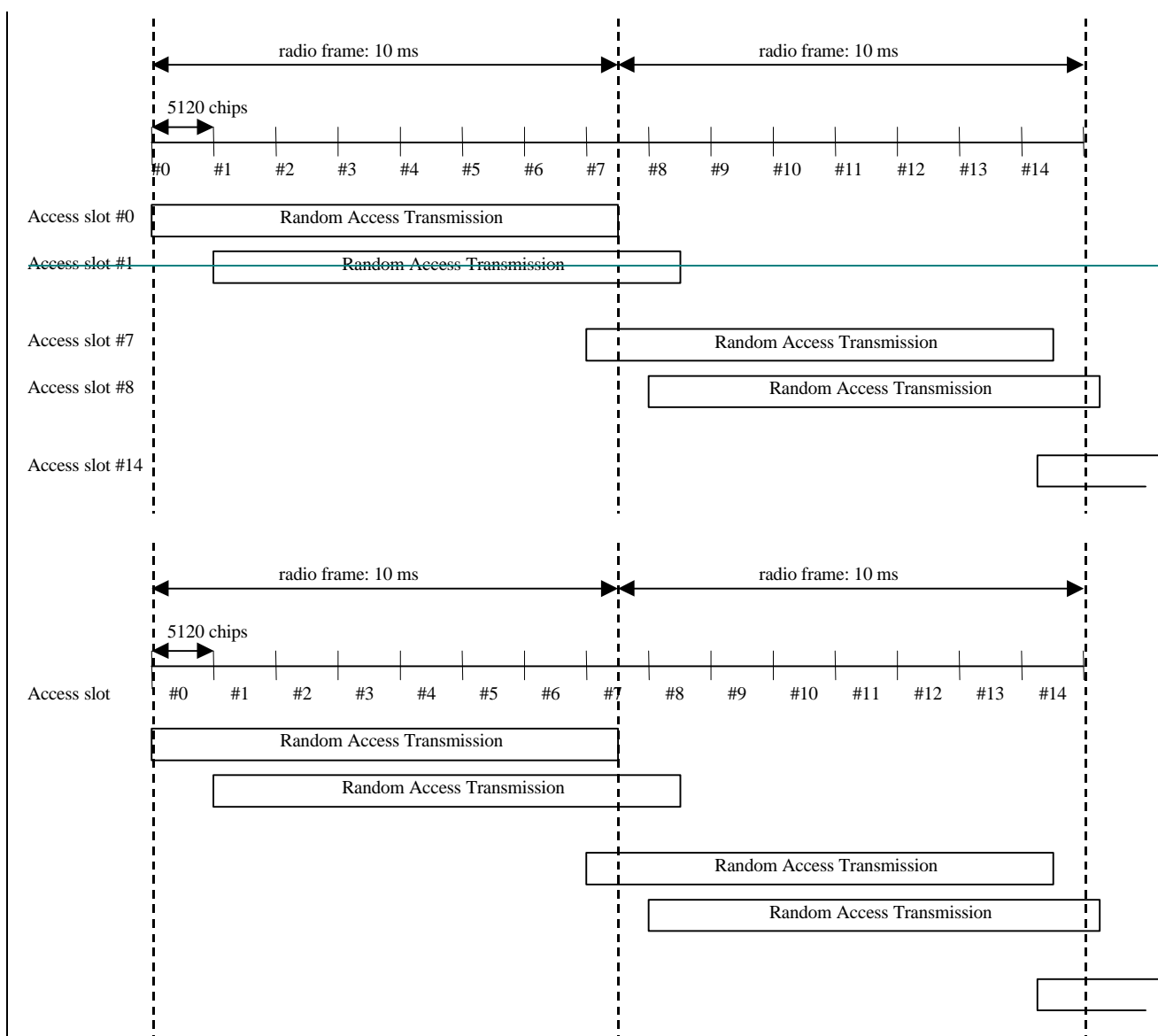

Figure 3: RACH access slot numbers and their spacing

The structure of the random-access transmission is shown in figure 4. The random-access transmission consists of one or several *preambles* of length 4096 chips and a *message* of length 10 ms or 20 ms. The UE indicates the length of the

message part to the network by using specific signatures and/or access slots. The assignment, which signatures and/or access slots are used for which message length, is performed by higher layers.

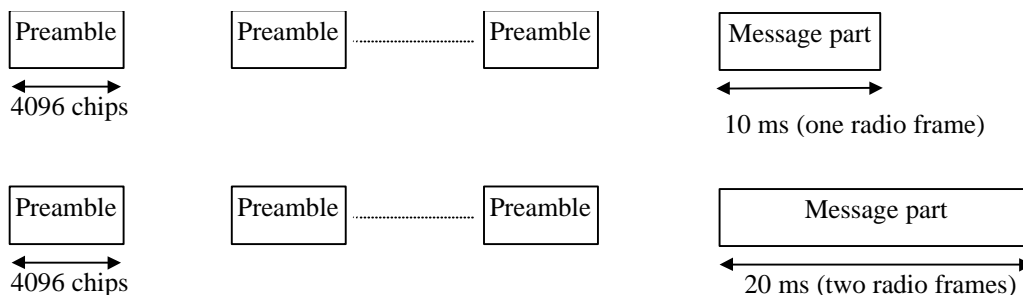

Figure 4: Structure of the random-access transmission

5.2.2.1.2 RACH preamble part

The Each preamble is of length 4096 chips and part of the random access burst consists of 256 repetitions of a signature of length 16 chips. There are a maximum total of 16 available different signatures, based on the Hadamard code set of length 16 (see [4] for more details).

5.2.2.1.3 RACH message part

Figure 5 shows the structure of the Random-access message part radio frame. The 10 ms message part radio frame is split into 15 slots, each of length $T_{slot} = 2560$ chips. Each slot consists of two parts, a data part to which the RACH transport channel is mapped and a control part that carries Layer 1 control information. The data and control parts are transmitted in parallel. A 10 ms message part consists of one message part radio frame, while a 20 ms long message part consists of two consecutive 10 ms message part radio frames. The message part length can be determined from the used signature and/or access slot, as configured by higher layers.

The data part consists of $10 \cdot 2^k$ bits, where $k=0,1,2,3$. This corresponds to a spreading factor of 256, 128, 64, and 32 respectively for the message data part.

The control part consists of 8 known pilot bits to support channel estimation for coherent detection and 2 TFCI bits. This corresponds to a spreading factor of 256 for the message control part. The pilot bit pattern is described in table 8. The total number of TFCI bits in the random-access message is $15 \cdot 2 = 30$. The TFCI of a radio frame indicates the transport format of the RACH transport channel mapped to the simultaneously transmitted message part radio frame. In case of a 20 ms PRACH message part, the TFCI is repeated in the second radio frame value corresponds to a certain transport format of the current Random access message.

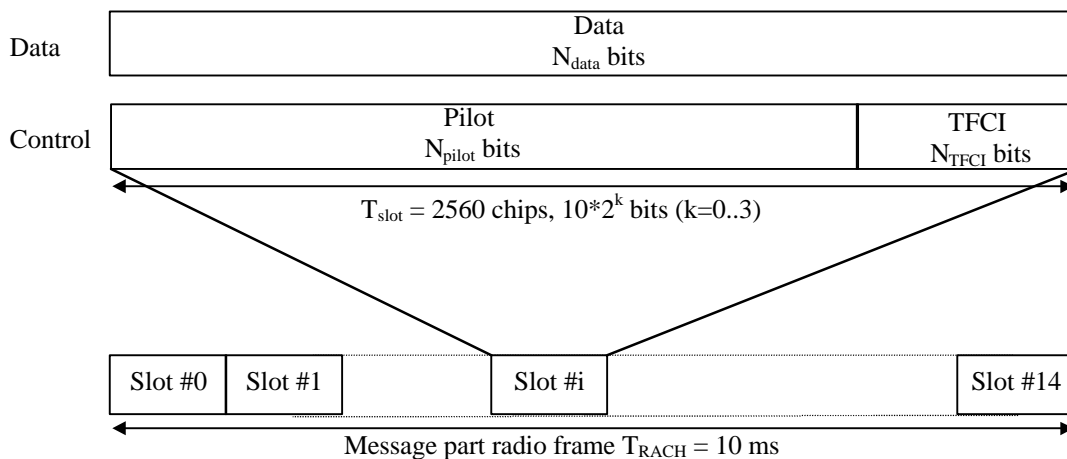

Figure 5: Structure of the random-access message part radio frame

Table 6: Random-access message data fields

| Slot Format #i | Channel Bit Rate (kbps) | Channel Symbol Rate (ksps) | SF | Bits/ Frame | Bits/ Slot | N _{data} |
|----------------|-------------------------|----------------------------|-----|-------------|------------|-------------------|
| 0 | 15 | 15 | 256 | 150 | 10 | 10 |
| 1 | 30 | 30 | 128 | 300 | 20 | 20 |
| 2 | 60 | 60 | 64 | 600 | 40 | 40 |
| 3 | 120 | 120 | 32 | 1200 | 80 | 80 |

Table 7: Random-access message control fields

| Slot Format #i | Channel Bit Rate (kbps) | Channel Symbol Rate (ksps) | SF | Bits/ Frame | Bits/ Slot | N _{pilot} | N _{TFCI} |
|----------------|-------------------------|----------------------------|-----|-------------|------------|--------------------|-------------------|
| 0 | 15 | 15 | 256 | 150 | 10 | 8 | 2 |

Table 8: Pilot bit patterns for RACH message part with N_{pilot} = 8

| Bit # | N _{pilot} = 8 | | | | | | | |
|---------|------------------------|---|---|---|---|---|---|---|
| | 0 | 1 | 2 | 3 | 4 | 5 | 6 | 7 |
| Slot #0 | 1 | 1 | 1 | 1 | 1 | 1 | 1 | 0 |
| 1 | 1 | 0 | 1 | 0 | 1 | 1 | 1 | 0 |
| 2 | 1 | 0 | 1 | 1 | 1 | 0 | 1 | 1 |
| 3 | 1 | 0 | 1 | 0 | 1 | 0 | 1 | 0 |
| 4 | 1 | 1 | 1 | 0 | 1 | 0 | 1 | 1 |
| 5 | 1 | 1 | 1 | 1 | 1 | 1 | 1 | 0 |
| 6 | 1 | 1 | 1 | 1 | 1 | 0 | 1 | 0 |
| 7 | 1 | 1 | 1 | 0 | 1 | 0 | 1 | 0 |
| 8 | 1 | 0 | 1 | 1 | 1 | 1 | 1 | 0 |
| 9 | 1 | 1 | 1 | 1 | 1 | 1 | 1 | 1 |
| 10 | 1 | 0 | 1 | 1 | 1 | 0 | 1 | 1 |
| 11 | 1 | 1 | 1 | 0 | 1 | 1 | 1 | 1 |
| 12 | 1 | 1 | 1 | 0 | 1 | 0 | 1 | 0 |
| 13 | 1 | 0 | 1 | 0 | 1 | 1 | 1 | 1 |
| 14 | 1 | 0 | 1 | 0 | 1 | 1 | 1 | 1 |

5.2.2.2 Physical Common Packet Channel (PCPCH)

The Physical Common Packet Channel (PCPCH) is used to carry the CPCH.

5.2.2.2.1 CPCH transmission

The CPCH transmission is based on DSMA-CD approach with fast acquisition indication. The UE can start transmission at a number of well-defined time-offsets, relative to the frame boundary of the received BCH of the current cell. The access slot timing and structure is identical to RACH in section 5.2.2.1.1. The structure of the CPCH random access transmission is shown in figure 6. The CPCH random access transmission consists of one or several Access Preambles [A-P] of length 4096 chips, one Collision Detection Preamble (CD-P) of length 4096 chips, a DPCCH Power Control Preamble (PC-P) which is either 0 slots or 8 slots in length, and a message of variable length N_x10 ms.

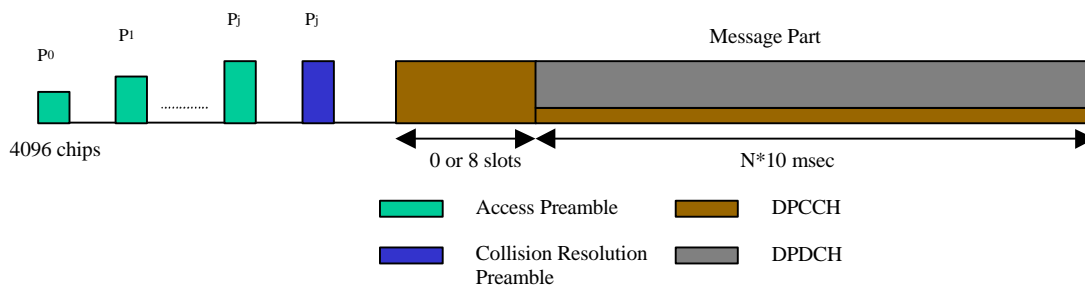

Figure 6: Structure of the CPCH random access transmission

5.2.2.2.2 CPCH access preamble part

Similar to 5.2.2.1.2 (RACH preamble part). The RACH preamble signature sequences are used. The number of sequences used could be less than the ones used in the RACH preamble. The scrambling code could either be chosen to be a different code segment of the Gold code used to form the scrambling code of the RACH preambles (see [4] for more details) or could be the same scrambling code in case the signature set is shared.

5.2.2.2.3 CPCH collision detection preamble part

Similar to 5.2.2.1.2 (RACH preamble part). The RACH preamble signature sequences are used. The scrambling code is chosen to be a different code segment of the Gold code used to form the scrambling code for the RACH and CPCH preambles (see [4] for more details).

5.2.2.2.4 CPCH power control preamble part

The power control preamble segment is a DPCCH Power Control Preamble (PC-P). The following table 9 is identical to Rows 2 and 4 of table 2 in section 5.2.1. Table 9 defines the DPCCH fields which only include Pilot, FBI and TPC bits. The Power Control Preamble length is a parameter which shall take the values 0 or 8 slots, as set by the higher layers.

Table 9: DPCCH fields for CPCH power control preamble segment

| Slot Format #i | Channel Bit Rate (kbps) | Channel Symbol Rate (ksps) | SF | Bits/ Frame | Bits/ Slot | N _{pilot} | N _{TFCI} | N _{FBI} | N _{TPC} |
|----------------|-------------------------|----------------------------|-----|-------------|------------|--------------------|-------------------|------------------|------------------|
| 0 | 15 | 15 | 256 | 150 | 10 | 8 | 0 | 0 | 2 |
| 1 | 15 | 15 | 256 | 150 | 10 | 7 | 0 | 1 | 2 |

5.2.2.2.5 CPCH message part

Figure 1 in section 5.2.1 shows the structure of the CPCH message part. Each message consists of up to N_Max_frames 10 ms frames. N_Max_frames is a higher layer parameter. Each 10 ms frame is split into 15 slots, each of length T_{slot} = 2560 chips. Each slot consists of two parts, a data part that carries higher layer information and a control part that carries Layer 1 control information. The data and control parts are transmitted in parallel.

The data part consists of 10*2^k bits, where k = 0, 1, 2, 3, 4, 5, 6, corresponding to spreading factors of 256, 128, 64, 32, 16, 8, 4 respectively. Note that various rates might be mapped to different signature sequences.

The spreading factor for the UL-DPCCH (message control part) is 256. The entries in table 1 corresponding to spreading factors of 256 and below and table 2 [both in section 5.2.1] apply to the DPDCH and DPCCH fields respectively for the CPCH message part.

5.3 Downlink physical channels

5.3.1 Downlink transmit diversity

Table 10 summarizes the possible application of open and closed loop transmit diversity modes on different downlink physical channel types. Simultaneous use of STTD and closed loop modes on the same physical channel (DPCH and PDSCH) is not allowed. Regarding CPICH transmission in case of transmit diversity, see section 5.3.3.1.

Table 10: Application of Tx diversity modes on downlink physical channel types
 "X" – can be applied, "-" – not applied

| Physical channel type | Open loop mode | | Closed loop mode |
|------------------------------|----------------|------|------------------|
| | TSTD | STTD | |
| P-CCPCH | - | X | - |
| SCH | X | - | - |
| S-CCPCH | - | X | - |
| DPCH | - | X | X |
| PICH | - | X | - |
| PDSCH (associated with DPCH) | - | X | X |
| AICH | - | X | - |

5.3.1.1 Open loop transmit diversity

5.3.1.1.1 Space time block coding based transmit antenna diversity (STTD)

The open loop downlink transmit diversity employs a space time block coding based transmit diversity (STTD). The STTD encoding is optional in UTRAN. STTD support is mandatory at the UE. STTD encoding is applied on blocks of 4 consecutive channel bits. A block diagram of a generic STTD encoder for channel bits b_0, b_1, b_2, b_3 is shown in the figure 7 below. Channel coding, rate matching and interleaving is done as in the non-diversity mode. The bit b_i is real valued {0} for DTX bits and {1, -1} for all other channel bits.

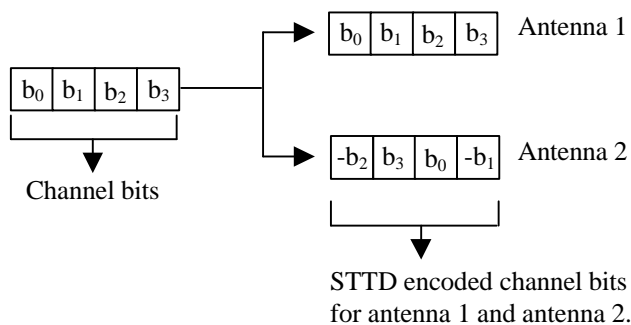

Figure 7: Generic block diagram of the STTD encoder

5.3.1.1.2 Time Switched Transmit Diversity for SCH (TSTD)

Transmit diversity, in the form of Time Switched Transmit Diversity (TSTD), can be applied to the SCH. TSTD for the SCH is optional in UTRAN, while TSTD support is mandatory in the UE. TSTD for the SCH is described in sub-clause 5.3.3.4.1.

5.3.1.2 Closed loop transmit diversity

Closed loop transmit diversity is described in [5].

5.3.2 Dedicated downlink physical channels

There is only one type of downlink dedicated physical channel, the Downlink Dedicated Physical Channel (downlink DPCH).

Within one downlink DPCH, dedicated data generated at Layer 2 and above, i.e. the dedicated transport channel (DCH), is transmitted in time-multiplex with control information generated at Layer 1 (known pilot bits, TPC commands, and an optional TFCI). The downlink DPCH can thus be seen as a time multiplex of a downlink DPDCH and a downlink DPCCH, compare section 5.2.1. ~~It is the UTRAN that determines if a TFCI should be transmitted, hence making it is mandatory for all UEs to support the use of TFCI in the downlink. In case of USTS, the TPC bits in slot #14 in frames with CFN mod 2 = 0 are replaced by Time Alignment Bits (TABs) as described in section 9.3 of [5]~~

Figure 8 shows the frame structure of the downlink DPCH. Each frame of length 10 ms is split into 15 slots, each of length $T_{slot} = 2560$ chips, corresponding to one power-control period.

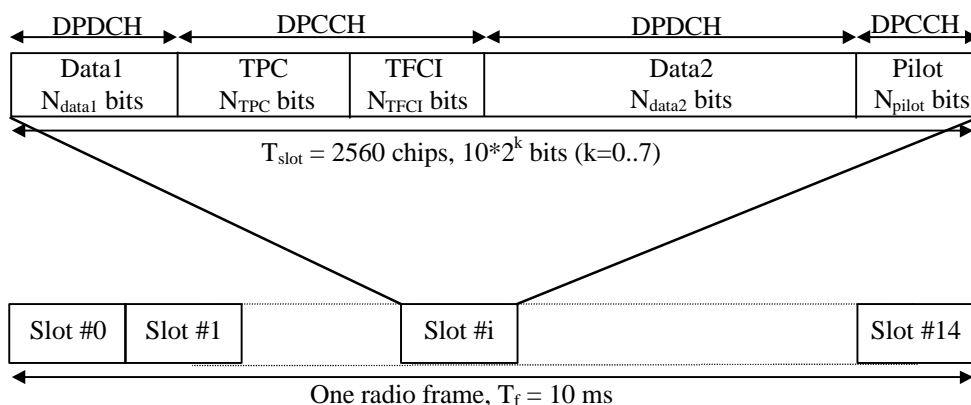

Figure 8: Frame structure for downlink DPCH

The parameter k in figure 8 determines the total number of bits per downlink DPCH slot. It is related to the spreading factor SF of the physical channel as $SF = 512/2^k$. The spreading factor may thus range from 512 down to 4.

The exact number of bits of the different downlink DPCH fields (N_{pilot} , N_{TPC} , N_{TFCI} , N_{data1} and N_{data2}) is ~~given determined~~ in table 11. ~~What slot format to use is configured by higher layers and can also be reconfigured by higher layers. The overhead due to the DPCCH transmission has to be negotiated at the connection set up and can be re-negotiated during the communication, in order to match particular propagation conditions.~~

There are basically two types of downlink Dedicated Physical Channels; those that include TFCI (e.g. for several simultaneous services) and those that do not include TFCI (e.g. for fixed-rate services). These types are reflected by the duplicated rows of table 11. ~~It is the UTRAN that determines if a TFCI should be transmitted and it is mandatory for all UEs to support the use of TFCI in the downlink. The mapping of TFCI bits onto slots is described in [3].~~

In compressed mode, a different slot format is used compared to normal mode. There are two possible compressed slot formats that are labelled A and B. Format B is used for compressed mode by spreading factor reduction and format A is used for all other transmission time reduction methods. The channel bit and symbol rates given in table 11 are the rates immediately before spreading.

Table 11: DPDCH and DPCCH fields

| Slot Format #i | Channel Bit Rate (kbps) | Channel Symbol Rate (ksps) | SF | Bits/Slot | DPDCH Bits/Slot | | DPCCH Bits/Slot | | | Transmitted slots per radio frame N _{Tr} |
|----------------|-------------------------|----------------------------|-----|-----------|--------------------|--------------------|------------------|-------------------|--------------------|---------------------------------------------------|
| | | | | | N _{Data1} | N _{Data2} | N _{TPC} | N _{TFCI} | N _{Pilot} | |
| 0 | 15 | 7.5 | 512 | 10 | 0 | 4 | 2 | 0 | 4 | 15 |
| 0A | 15 | 7.5 | 512 | 10 | 0 | 4 | 2 | 0 | 4 | 8-14 |
| 0B | 30 | 15 | 256 | 20 | 0 | 8 | 4 | 0 | 8 | 8-14 |
| 1 | 15 | 7.5 | 512 | 10 | 0 | 2 | 2 | 2 | 4 | 15 |
| 1B | 30 | 15 | 256 | 20 | 0 | 4 | 4 | 4 | 8 | 8-14 |
| 2 | 30 | 15 | 256 | 20 | 2 | 14 | 2 | 0 | 2 | 15 |
| 2A | 30 | 15 | 256 | 20 | 2 | 14 | 2 | 0 | 2 | 8-14 |
| 2B | 60 | 30 | 128 | 40 | 4 | 28 | 4 | 0 | 4 | 8-14 |
| 3 | 30 | 15 | 256 | 20 | 2 | 12 | 2 | 2 | 2 | 15 |
| 3A | 30 | 15 | 256 | 20 | 2 | 10 | 2 | 4 | 2 | 8-14 |
| 3B | 60 | 30 | 128 | 40 | 4 | 24 | 4 | 4 | 4 | 8-14 |
| 4 | 30 | 15 | 256 | 20 | 2 | 12 | 2 | 0 | 4 | 15 |
| 4A | 30 | 15 | 256 | 20 | 2 | 12 | 2 | 0 | 4 | 8-14 |
| 4B | 60 | 30 | 128 | 40 | 4 | 24 | 4 | 0 | 8 | 8-14 |
| 5 | 30 | 15 | 256 | 20 | 2 | 10 | 2 | 2 | 4 | 15 |
| 5A | 30 | 15 | 256 | 20 | 2 | 8 | 2 | 4 | 4 | 8-14 |
| 5B | 60 | 30 | 128 | 40 | 4 | 20 | 4 | 4 | 8 | 8-14 |
| 6 | 30 | 15 | 256 | 20 | 2 | 8 | 2 | 0 | 8 | 15 |
| 6A | 30 | 15 | 256 | 20 | 2 | 8 | 2 | 0 | 8 | 8-14 |
| 6B | 60 | 30 | 128 | 40 | 4 | 16 | 4 | 0 | 16 | 8-14 |
| 7 | 30 | 15 | 256 | 20 | 2 | 6 | 2 | 2 | 8 | 15 |
| 7A | 30 | 15 | 256 | 20 | 2 | 4 | 2 | 4 | 8 | 8-14 |
| 7B | 60 | 30 | 128 | 40 | 4 | 12 | 4 | 4 | 16 | 8-14 |
| 8 | 60 | 30 | 128 | 40 | 6 | 28 | 2 | 0 | 4 | 15 |
| 8A | 60 | 30 | 128 | 40 | 6 | 28 | 2 | 0 | 4 | 8-14 |
| 8B | 120 | 60 | 64 | 80 | 12 | 56 | 4 | 0 | 8 | 8-14 |
| 9 | 60 | 30 | 128 | 40 | 6 | 26 | 2 | 2 | 4 | 15 |
| 9A | 60 | 30 | 128 | 40 | 6 | 24 | 2 | 4 | 4 | 8-14 |
| 9B | 120 | 60 | 64 | 80 | 12 | 52 | 4 | 4 | 8 | 8-14 |
| 10 | 60 | 30 | 128 | 40 | 6 | 24 | 2 | 0 | 8 | 15 |
| 10A | 60 | 30 | 128 | 40 | 6 | 24 | 2 | 0 | 8 | 8-14 |
| 10B | 120 | 60 | 64 | 80 | 12 | 48 | 4 | 0 | 16 | 8-14 |
| 11 | 60 | 30 | 128 | 40 | 6 | 22 | 2 | 2 | 8 | 15 |
| 11A | 60 | 30 | 128 | 40 | 6 | 20 | 2 | 4 | 8 | 8-14 |
| 11B | 120 | 60 | 64 | 80 | 12 | 44 | 4 | 4 | 16 | 8-14 |
| 12 | 120 | 60 | 64 | 80 | 12 | 48 | 4 | 8* | 8 | 15 |
| 12A | 120 | 60 | 64 | 80 | 12 | 40 | 4 | 16* | 8 | 8-14 |
| 12B | 240 | 120 | 32 | 160 | 24 | 96 | 8 | 16* | 16 | 8-14 |
| 13 | 240 | 120 | 32 | 160 | 28 | 112 | 4 | 8* | 8 | 15 |
| 13A | 240 | 120 | 32 | 160 | 28 | 104 | 4 | 16* | 8 | 8-14 |
| 13B | 480 | 240 | 16 | 320 | 56 | 224 | 8 | 16* | 16 | 8-14 |
| 14 | 480 | 240 | 16 | 320 | 56 | 232 | 8 | 8* | 16 | 15 |
| 14A | 480 | 240 | 16 | 320 | 56 | 224 | 8 | 16* | 16 | 8-14 |
| 14B | 960 | 480 | 8 | 640 | 112 | 464 | 16 | 16* | 32 | 8-14 |
| 15 | 960 | 480 | 8 | 640 | 120 | 488 | 8 | 8* | 16 | 15 |
| 15A | 960 | 480 | 8 | 640 | 120 | 480 | 8 | 16* | 16 | 8-14 |
| 15B | 1920 | 960 | 4 | 1280 | 240 | 976 | 16 | 16* | 32 | 8-14 |
| 16 | 1920 | 960 | 4 | 1280 | 248 | 1000 | 8 | 8* | 16 | 15 |
| 16A | 1920 | 960 | 4 | 1280 | 248 | 992 | 8 | 16* | 16 | 8-14 |

* If TFCI bits are not used, then DTX shall be used in TFCI field.

NOTE1: Compressed mode is only supported through spreading factor reduction for SF=512 with TFCI.

NOTE2: Compressed mode by spreading factor reduction is not supported for SF=4.

The pilot symbol pattern is described in table 12. The shadowed part can be used as frame synchronization words. (The symbol pattern of the pilot symbols other than the frame synchronization word shall be "11".) In table 12, the transmission order is from left to right. ~~(Each two-bit pair represents an I/Q pair of QPSK modulation.)~~

In downlink compressed mode through spreading factor reduction, the number of bits in the TPC and Pilot fields are doubled. Symbol repetition is used to fill up the fields. Denote the bits in one of these fields in normal mode by $x_1, x_2, x_3, \dots, x_X$. In compressed mode the following bit sequence is sent in corresponding field: $x_1, x_2, x_1, x_2, x_3, x_4, x_3, x_4, \dots, x_X$.

Table 12: Pilot Symbol Pattern

| Symbol # | Npilot = 2 | Npilot = 4 | | Npilot = 8 | | | | Npilot = 16 | | | | | | | |
|----------|------------|------------|----|------------|----|----|----|-------------|----|----|----|----|----|----|----|
| | 0 | 0 | 1 | 0 | 1 | 2 | 3 | 0 | 1 | 2 | 3 | 4 | 5 | 6 | 7 |
| Slot #0 | 11 | 11 | 11 | 11 | 11 | 11 | 10 | 11 | 11 | 11 | 10 | 11 | 11 | 11 | 10 |
| 1 | 00 | 11 | 00 | 11 | 00 | 11 | 10 | 11 | 00 | 11 | 10 | 11 | 11 | 11 | 00 |
| 2 | 01 | 11 | 01 | 11 | 01 | 11 | 01 | 11 | 01 | 11 | 01 | 11 | 10 | 11 | 00 |
| 3 | 00 | 11 | 00 | 11 | 00 | 11 | 00 | 11 | 00 | 11 | 00 | 11 | 01 | 11 | 10 |
| 4 | 10 | 11 | 10 | 11 | 10 | 11 | 01 | 11 | 10 | 11 | 01 | 11 | 11 | 11 | 11 |
| 5 | 11 | 11 | 11 | 11 | 11 | 11 | 10 | 11 | 11 | 11 | 10 | 11 | 01 | 11 | 01 |
| 6 | 11 | 11 | 11 | 11 | 11 | 11 | 00 | 11 | 11 | 11 | 00 | 11 | 10 | 11 | 11 |
| 7 | 10 | 11 | 10 | 11 | 10 | 11 | 00 | 11 | 10 | 11 | 00 | 11 | 10 | 11 | 00 |
| 8 | 01 | 11 | 01 | 11 | 01 | 11 | 10 | 11 | 01 | 11 | 10 | 11 | 00 | 11 | 11 |
| 9 | 11 | 11 | 11 | 11 | 11 | 11 | 11 | 11 | 11 | 11 | 11 | 11 | 00 | 11 | 11 |
| 10 | 01 | 11 | 01 | 11 | 01 | 11 | 01 | 11 | 01 | 11 | 01 | 11 | 11 | 11 | 10 |
| 11 | 10 | 11 | 10 | 11 | 10 | 11 | 11 | 11 | 10 | 11 | 11 | 11 | 00 | 11 | 10 |
| 12 | 10 | 11 | 10 | 11 | 10 | 11 | 00 | 11 | 10 | 11 | 00 | 11 | 01 | 11 | 01 |
| 13 | 00 | 11 | 00 | 11 | 00 | 11 | 11 | 11 | 00 | 11 | 11 | 11 | 00 | 11 | 00 |
| 14 | 00 | 11 | 00 | 11 | 00 | 11 | 11 | 11 | 00 | 11 | 11 | 11 | 10 | 11 | 01 |

The relationship between the TPC symbol and the transmitter power control command is presented in table 13.

Table 13: TPC Bit Pattern

| TPC Bit Pattern | | | Transmitter power control command |
|----------------------|----------------------|----------------------|-----------------------------------|
| N _{TPC} = 2 | N _{TPC} = 4 | N _{TPC} = 8 | |
| 11 | 1111 | 11111111 | 1 |
| 00 | 0000 | 00000000 | 0 |

~~For slot formats using TFCI, the TFCI word value in each radio frame informs the receiver about the instantaneous transport format combination of the transport channels simultaneously mapped to the DPCH radio frame corresponds to a certain combination of bit rates of the DCHs currently in use. This correspondence is (re-)negotiated at each DCH addition/removal. The mapping of the TFCI bits onto slots is described in [3].~~

~~When the total bit rate to be transmitted on one downlink CCTrCH exceeds the maximum bit rate for a downlink physical channel, multicode transmission may be employed in the downlink, i.e. the CCTrCH (see [3]) is mapped onto several parallel downlink DPCHs are transmitted for one CCTrCH, using the same spreading factor. In this case, the Layer 1 control information is transmitted on only on the first downlink DPCH. DTX bits are transmitted during the corresponding time period for (The additional downlink DPCHs belonging to the CCTrCH do not transmit any data during the corresponding time period, see figure 9.~~

~~In the case there are of several CCTrCHs mapped to different DPCHs transmitted to the same UE of dedicated type for one UE different spreading factors can be used on DPCHs to which different for each CCTrCHs are mapped. Also in this case, Layer 1 control information is only transmitted on the first DPCH while DTX bits are transmitted during the corresponding time period for the additional DPCHs and only one DPCH would be transmitted for them in the downlink.~~

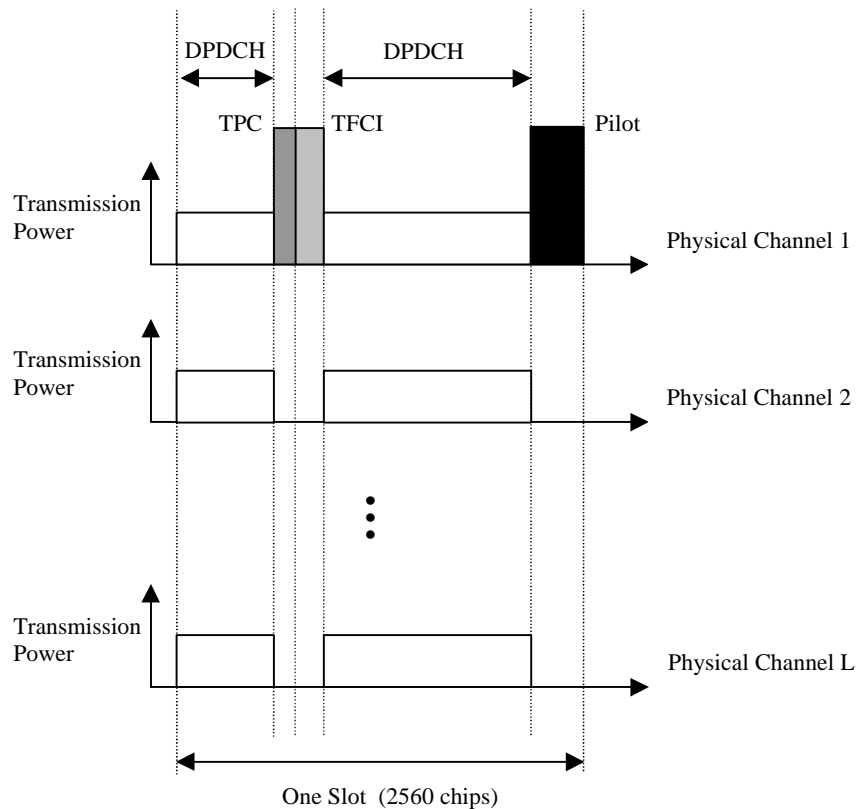

Figure 9: Downlink slot format in case of multi-code transmission

5.3.2.1 STTD for DPCH

The pilot bit pattern for the DPCH channel transmitted on ~~the diversity~~ antenna 2 is given in table 14. The shadowed part indicates pilot bits that are STTD encoded from the corresponding (shadowed) bits in Table 12. For the SF=256 DPCH, if there are only two dedicated pilot bits ($N_{\text{pilot}} = 2$ in Tables 12 and 14), they are STTD encoded together with the last two bits (data or DTX) of the second data field (data2) of the slot. STTD encoding for the DPDCCH, TPC, and TFCI fields is done as described in section 5.3.1.1.1. For the SF=512 DPCH, the first two bits in each slot, i.e. TPC bits, are not STTD encoded and the same bits are transmitted with equal power from the two antennas. The following four bits are STTD encoded.

Table 14: Pilot pattern of the DPCH channel for ~~the diversity~~ antenna 2 using STTD

| Symbol # | Npilot = 2 | Npilot = 4 | | Npilot = 8 | | | | Npilot = 16 | | | | | | | |
|----------|------------|------------|----|------------|----|----|----|-------------|----|----|----|----|----|----|----|
| | 0 | 0 | 1 | 0 | 1 | 2 | 3 | 0 | 1 | 2 | 3 | 4 | 5 | 6 | 7 |
| Slot #0 | 01 | 01 | 10 | 11 | 00 | 00 | 10 | 11 | 00 | 00 | 10 | 11 | 00 | 00 | 10 |
| 1 | 10 | 10 | 10 | 11 | 00 | 00 | 01 | 11 | 00 | 00 | 01 | 11 | 10 | 00 | 10 |
| 2 | 11 | 11 | 10 | 11 | 11 | 00 | 00 | 11 | 11 | 00 | 00 | 11 | 10 | 00 | 11 |
| 3 | 10 | 10 | 10 | 11 | 10 | 00 | 01 | 11 | 10 | 00 | 01 | 11 | 00 | 00 | 00 |
| 4 | 00 | 00 | 10 | 11 | 11 | 00 | 11 | 11 | 11 | 00 | 11 | 11 | 01 | 00 | 10 |
| 5 | 01 | 01 | 10 | 11 | 00 | 00 | 10 | 11 | 00 | 00 | 10 | 11 | 11 | 00 | 00 |
| 6 | 01 | 01 | 10 | 11 | 10 | 00 | 10 | 11 | 10 | 00 | 10 | 11 | 01 | 00 | 11 |
| 7 | 00 | 00 | 10 | 11 | 10 | 00 | 11 | 11 | 10 | 00 | 11 | 11 | 10 | 00 | 11 |
| 8 | 11 | 11 | 10 | 11 | 00 | 00 | 00 | 11 | 00 | 00 | 00 | 11 | 01 | 00 | 01 |
| 9 | 01 | 01 | 10 | 11 | 01 | 00 | 10 | 11 | 01 | 00 | 10 | 11 | 01 | 00 | 01 |
| 10 | 11 | 11 | 10 | 11 | 11 | 00 | 00 | 11 | 11 | 00 | 00 | 11 | 00 | 00 | 10 |
| 11 | 00 | 00 | 10 | 11 | 01 | 00 | 11 | 11 | 01 | 00 | 11 | 11 | 00 | 00 | 01 |
| 12 | 00 | 00 | 10 | 11 | 10 | 00 | 11 | 11 | 10 | 00 | 11 | 11 | 11 | 00 | 00 |
| 13 | 10 | 10 | 10 | 11 | 01 | 00 | 01 | 11 | 01 | 00 | 01 | 11 | 10 | 00 | 01 |
| 14 | 10 | 10 | 10 | 11 | 01 | 00 | 01 | 11 | 01 | 00 | 01 | 11 | 11 | 00 | 11 |

5.3.2.2 Dedicated channel pilots with closed loop mode transmit diversity

In closed loop mode 1 orthogonal pilot patterns are used between the transmit antennas. Pilot patterns defined in the table 12 will be used on ~~the non diversity~~ antenna 1 and pilot patterns defined in the table 14 on ~~the diversity~~ antenna 2. This is illustrated in the figure 10 a which indicates the difference in the pilot patterns with different shading.

In closed loop mode 2 same pilot pattern is used on both of the antennas (see figure 10 b). The pattern to be used is according to the table 12.

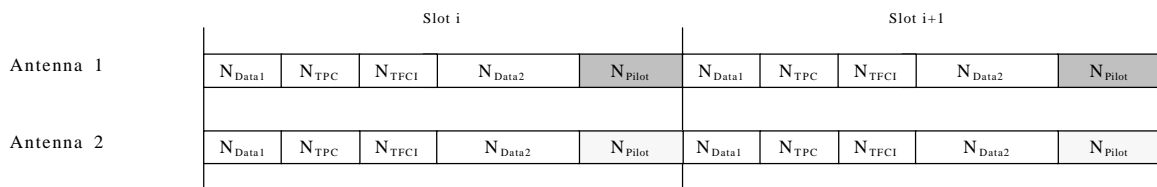

(a)

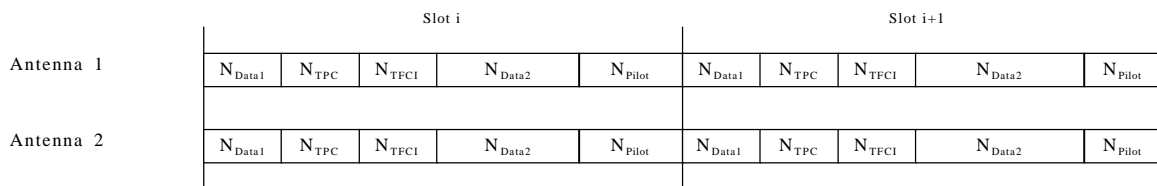

(b)

Figure 10: Slot structures for downlink dedicated physical channel diversity transmission.

Structure (a) is used in closed loop mode 1.

Structure (b) is used in closed loop mode 2.

Different shading of the pilots indicate orthogonality of the patterns

5.3.2.3 DL-DPCCH for CPCH

The spreading factor for the UL-DPCCH (message control part) is 256. The spreading factor for the DL-DPCCH (message control part) is 512. The following table 15 shows the DL-DPCCH fields (message control part) which are identical to the first row of table 11 in section 5.3.2.

Table 15: DPDCH and DPCCH fields for CPCH message transmission

| Slot Format #i | Channel Bit Rate (kbps) | Channel Symbol Rate (ksps) | SF | Bits/Frame | | | Bits/Slot | DPDCH Bits/Slot | | DPCCH Bits/Slot | | |
|----------------|-------------------------|----------------------------|-----|------------|-------|-----|-----------|-----------------|--------|-----------------|------|--------|
| | | | | DPDCH | DPCCH | TOT | | NData1 | NData2 | NTFCI | NTPC | NPilot |
| 0 | 15 | 7.5 | 512 | 60 | 90 | 150 | 10 | 2 | 2 | 0 | 2 | 4 |

5.3.3 Common downlink physical channels

5.3.3.1 Common Pilot Channel (CPICH)

The CPICH is a fixed rate (30 kbps, SF=256) downlink physical channel that carries a pre-defined bit/symbol sequence. Figure 11 shows the frame structure of the CPICH.

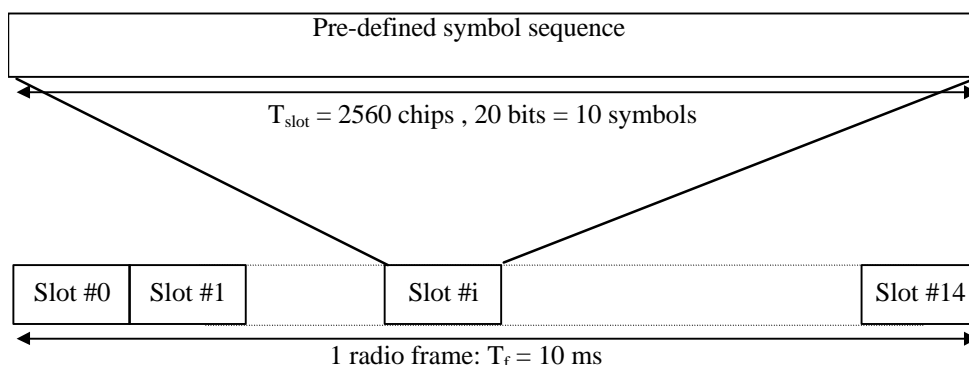

Figure 11: Frame structure for Common Pilot Channel

In case of Transmit Diversity (open or closed loop) is used on any downlink channel in the cell, the CPICH shall be transmitted from both antennas using the same channelization and scrambling code. In this case, the pre-defined symbol sequence of the CPICH is different for Antenna 1 and Antenna 2, see figure 12. In case of no Transmit Diversity, the symbol sequence of Antenna 1 in figure 12 is used.

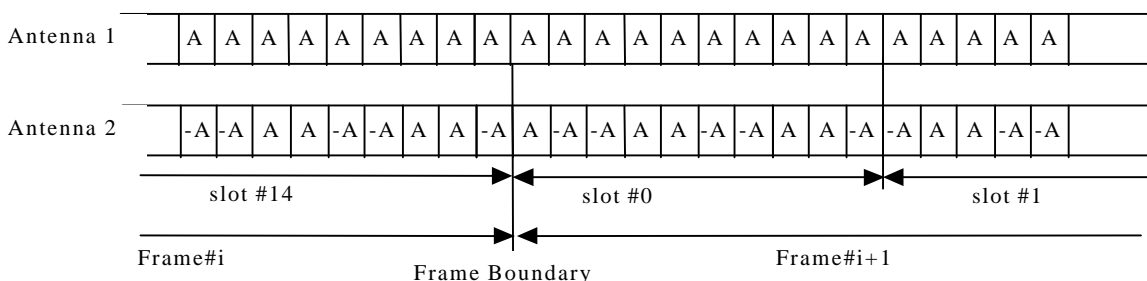

Figure 12: Modulation pattern for Common Pilot Channel (with A = 1+j)

There are two types of Common pilot channels, the Primary and Secondary CPICH. They differ in their use and the limitations placed on their physical features.

5.3.3.1.1 Primary Common Pilot Channel (P-CPICH)

The Primary Common Pilot Channel (P-CPICH) has the following characteristics:

- The same channelization code is always used for ~~the P-CPICH~~this channel, see [4]
- ~~The P-CPICH is S~~scrambled by the primary scrambling code, see [4]
- ~~There is one and only o~~ne P-CPICH per cell
- ~~The P-CPICH is B~~roadcast over the entire cell

The Primary CPICH is the phase reference for the following downlink channels: SCH, Primary CCPCH, AICH, PICH. The Primary CPICH is also the *default* phase reference for all other downlink physical channels.

5.3.3.1.2 Secondary Common Pilot Channel (S-CPICH)

A Secondary Common Pilot Channel (S-CPICH) ~~has~~has the following characteristics:

- ~~A~~Can use an arbitrary channelization code of -SF=256 ~~is used for the S-CPICH~~, see [4]
- ~~A S-CPICH is S~~scrambled by either the primary or a secondary scrambling code, see [4]
- ~~There may be Z~~zero, one, or several S-CPICH per cell
- ~~A S-CPICH M~~ay be transmitted over the entire cell or only over a part of the cell
- A Secondary CPICH may be the reference for the Secondary CCPCH and the downlink DPCH. If this is the case, the UE is informed about this by higher-layer signalling.

5.3.3.2 Primary Common Control Physical Channel (P-CCPCH)

The Primary CCPCH is a fixed rate (30 kbps, SF=256) downlink physical channels used to carry the BCH transport channel.

Figure 13 shows the frame structure of the Primary CCPCH. The frame structure differs from the downlink DPCH in that no TPC commands, no TFCI and no pilot bits are transmitted. The Primary CCPCH is not transmitted during the first 256 chips of each slot. Instead, Primary SCH and Secondary SCH are transmitted during this period (see section 5.3.3.4).

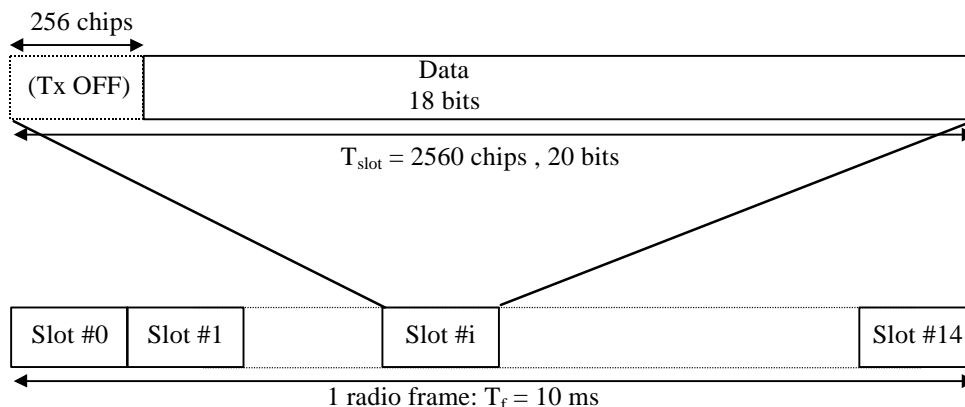

Figure 13: Frame structure for Primary Common Control Physical Channel

5.3.3.2.1 Primary CCPCH structure with STTD encoding

In case the diversity antenna is present in UTRAN and the P-CCPCH is to be transmitted using open loop transmit diversity, the data bits of the P-CCPCH are STTD encoded as given in section 5.3.1.1.1. The last two data bits in even numbered slots are STTD encoded together with the first two data bits in the following slot, except for slot #14 where the two last data bits are not STTD encoded and instead transmitted with equal power from both the antennas, see figure 14. Higher layers signal whether STTD encoding is used for the P-CCPCH or not. In addition, ~~higher layer signalling indicates~~ the presence/absence of STTD encoding on P-CCPCH ~~is indicated~~, by modulating the SCH, ~~see 5.3.3.4~~. During power on and hand over between cells the UE ~~can~~ determines the presence of STTD encoding on the P-CCPCH, by either receiving the higher layer message, by demodulating the SCH channel, or by a combination of the above two schemes.

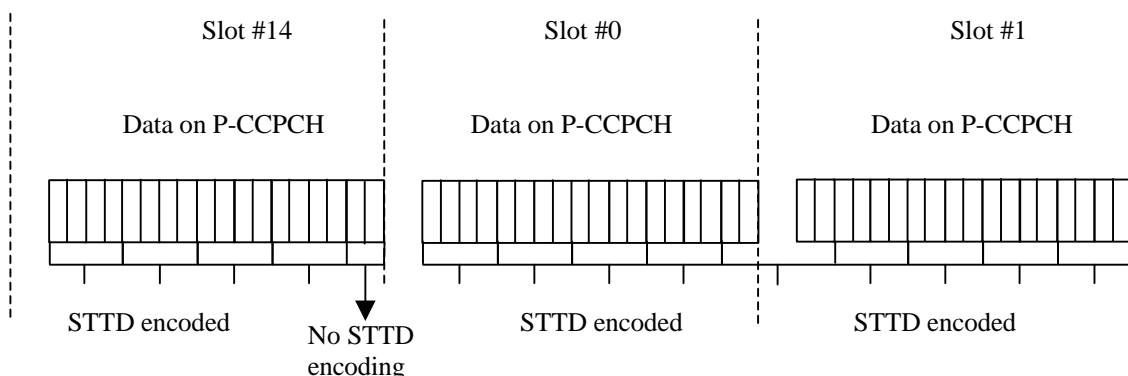

Figure 14: STTD encoding for the data bits of the P-CCPCH

5.3.3.3 Secondary Common Control Physical Channel (S-CCPCH)

The Secondary CCPCH is used to carry the FACH and PCH. There are two types of Secondary CCPCH: those that include TFCI and those that do not include TFCI. It is the UTRAN that determines if a TFCI should be transmitted, hence making it mandatory for all UEs to support the use of TFCI. The set of possible rates ~~for the Secondary CCPCH~~ is the same as for the downlink DPCH, see section 5.3.2. The frame structure of the Secondary CCPCH is shown in figure 15.

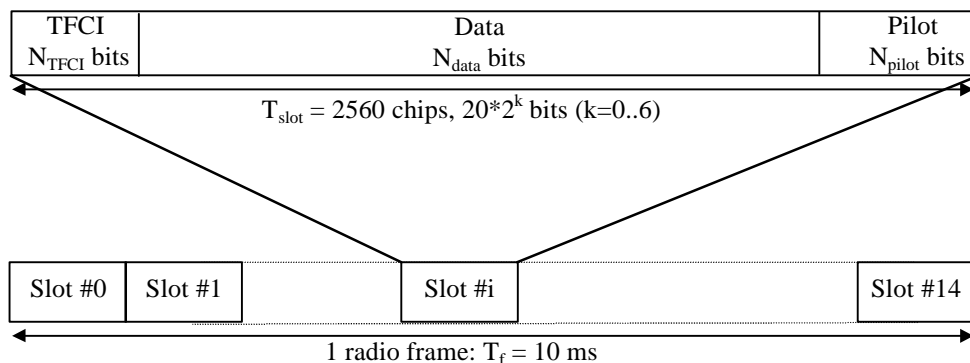

Figure 15: Frame structure for Secondary Common Control Physical Channel

The parameter k in figure 15 determines the total number of bits per downlink Secondary CCPCH slot. It is related to the spreading factor SF of the physical channel as $SF = 256/2^k$. The spreading factor range is from 256 down to 4.

The values for the number of bits per field are given in table 16. The channel bit and symbol rates given in table 16 are the rates immediately before spreading. The pilot patterns are given in table 17.

The FACH and PCH can be mapped to the same or to separate Secondary CCPCHs. If FACH and PCH are mapped to the same Secondary CCPCH, they can be mapped to the same frame. The main difference between a CCPCH and a downlink dedicated physical channel is that a CCPCH is not inner-loop power controlled. The main difference between the Primary and Secondary CCPCH is that the transport channel mapped to the Primary CCPCH (BCH) can only have ~~has~~ a fixed predefined transport format combination, rate while the Secondary CCPCH ~~can~~ support multiple transport format combinations using variable rate with the help of the TFCI field included. Furthermore, a Primary CCPCH is continuously transmitted over the entire cell while a Secondary CCPCH is only transmitted when there is data available and may be transmitted in a narrow lobe in the same way as a dedicated physical channel (only valid for a Secondary CCPCH carrying the FACH).

Table 16: Secondary CCPCH fields

| Slot Format #i | Channel Bit Rate (kbps) | Channel Symbol Rate (ksps) | SF | Bits/ Frame | Bits/ Slot | N _{data} | N _{pilot} | N _{TFCI} |
|----------------|-------------------------|----------------------------|-----|-------------|------------|-------------------|--------------------|-------------------|
| 0 | 30 | 15 | 256 | 300 | 20 | 20 | 0 | 0 |
| 1 | 30 | 15 | 256 | 300 | 20 | 12 | 8 | 0 |
| 2 | 30 | 15 | 256 | 300 | 20 | 18 | 0 | 2 |
| 3 | 30 | 15 | 256 | 300 | 20 | 10 | 8 | 2 |
| 4 | 60 | 30 | 128 | 600 | 40 | 40 | 0 | 0 |
| 5 | 60 | 30 | 128 | 600 | 40 | 32 | 8 | 0 |
| 6 | 60 | 30 | 128 | 600 | 40 | 38 | 0 | 2 |
| 7 | 60 | 30 | 128 | 600 | 40 | 30 | 8 | 2 |
| 8 | 120 | 60 | 64 | 1200 | 80 | 72 | 0 | 8* |
| 9 | 120 | 60 | 64 | 1200 | 80 | 64 | 8 | 8* |
| 10 | 240 | 120 | 32 | 2400 | 160 | 152 | 0 | 8* |
| 11 | 240 | 120 | 32 | 2400 | 160 | 144 | 8 | 8* |
| 12 | 480 | 240 | 16 | 4800 | 320 | 312 | 0 | 8* |
| 13 | 480 | 240 | 16 | 4800 | 320 | 296 | 16 | 8* |
| 14 | 960 | 480 | 8 | 9600 | 640 | 632 | 0 | 8* |
| 15 | 960 | 480 | 8 | 9600 | 640 | 616 | 16 | 8* |
| 16 | 1920 | 960 | 4 | 19200 | 1280 | 1272 | 0 | 8* |
| 17 | 1920 | 960 | 4 | 19200 | 1280 | 1256 | 16 | 8* |

* If TFCI bits are not used, then DTX shall be used in TFCI field.

The pilot symbol pattern is described in table 17. The shadowed part can be used as frame synchronization words. (The symbol pattern of pilot symbols other than the frame synchronization word shall be "11"). In table 17, the transmission order is from left to right. (Each two-bit pair represents an I/Q pair of QPSK modulation.)

Table 17: Pilot Symbol Pattern

| Symbol # | N _{pilot} = 8 | | | | N _{pilot} = 16 | | | | | | | |
|----------|------------------------|----|----|----|-------------------------|----|----|----|----|----|----|----|
| | 0 | 1 | 2 | 3 | 0 | 1 | 2 | 3 | 4 | 5 | 6 | 7 |
| Slot #0 | 11 | 11 | 11 | 10 | 11 | 11 | 11 | 10 | 11 | 11 | 11 | 10 |
| 1 | 11 | 00 | 11 | 10 | 11 | 00 | 11 | 10 | 11 | 11 | 11 | 00 |
| 2 | 11 | 01 | 11 | 01 | 11 | 01 | 11 | 01 | 11 | 10 | 11 | 00 |
| 3 | 11 | 00 | 11 | 00 | 11 | 00 | 11 | 00 | 11 | 01 | 11 | 10 |
| 4 | 11 | 10 | 11 | 01 | 11 | 10 | 11 | 01 | 11 | 11 | 11 | 11 |
| 5 | 11 | 11 | 11 | 10 | 11 | 11 | 11 | 10 | 11 | 01 | 11 | 01 |
| 6 | 11 | 11 | 11 | 00 | 11 | 11 | 11 | 00 | 11 | 10 | 11 | 11 |
| 7 | 11 | 10 | 11 | 00 | 11 | 10 | 11 | 00 | 11 | 10 | 11 | 00 |
| 8 | 11 | 01 | 11 | 10 | 11 | 01 | 11 | 10 | 11 | 00 | 11 | 11 |
| 9 | 11 | 11 | 11 | 11 | 11 | 11 | 11 | 11 | 11 | 00 | 11 | 11 |
| 10 | 11 | 01 | 11 | 01 | 11 | 01 | 11 | 01 | 11 | 11 | 11 | 10 |
| 11 | 11 | 10 | 11 | 11 | 11 | 10 | 11 | 11 | 11 | 00 | 11 | 10 |
| 12 | 11 | 10 | 11 | 00 | 11 | 10 | 11 | 00 | 11 | 01 | 11 | 01 |
| 13 | 11 | 00 | 11 | 11 | 11 | 00 | 11 | 11 | 11 | 00 | 11 | 00 |
| 14 | 11 | 00 | 11 | 11 | 11 | 00 | 11 | 11 | 11 | 10 | 11 | 01 |

For slot formats using TFCI, the TFCI value in each radio frame corresponds to a certain transport format combination of the FACHs and/or PCHs currently in use. This correspondence is (re-)negotiated at each FACH/PCH addition/removal. The mapping of the TFCI bits onto slots is described in [3].

5.3.3.3.1 Secondary CCPCH structure with STTD encoding

In case the diversity antenna is present in UTRAN and the S-CCPCH is to be transmitted using open loop transmit diversity, the data symbols of the S-CCPCH are STTD encoded as given in Section 5.3.1.1.1. The ~~diversity antenna~~ pilot symbol pattern ~~for antenna 2~~ for the S-CCPCH is given in table 18 below.

Table 18: Pilot symbol pattern for ~~the diversity antenna 2~~ when STTD encoding is used on the S-CCPCH

| Symbol # | N _{pilot} = 8 | | | | N _{pilot} = 16 | | | | | | | |
|----------|------------------------|----|----|----|-------------------------|----|----|----|----|----|----|----|
| | 0 | 1 | 2 | 3 | 0 | 1 | 2 | 3 | 4 | 5 | 6 | 7 |
| Slot #0 | 11 | 00 | 00 | 10 | 11 | 00 | 00 | 10 | 11 | 00 | 00 | 10 |
| 1 | 11 | 00 | 00 | 01 | 11 | 00 | 00 | 01 | 11 | 10 | 00 | 10 |
| 2 | 11 | 11 | 00 | 00 | 11 | 11 | 00 | 00 | 11 | 10 | 00 | 11 |
| 3 | 11 | 10 | 00 | 01 | 11 | 10 | 00 | 01 | 11 | 00 | 00 | 00 |
| 4 | 11 | 11 | 00 | 11 | 11 | 11 | 00 | 11 | 11 | 01 | 00 | 10 |
| 5 | 11 | 00 | 00 | 10 | 11 | 00 | 00 | 10 | 11 | 11 | 00 | 00 |
| 6 | 11 | 10 | 00 | 10 | 11 | 10 | 00 | 10 | 11 | 01 | 00 | 11 |
| 7 | 11 | 10 | 00 | 11 | 11 | 10 | 00 | 11 | 11 | 10 | 00 | 11 |
| 8 | 11 | 00 | 00 | 00 | 11 | 00 | 00 | 00 | 11 | 01 | 00 | 01 |
| 9 | 11 | 01 | 00 | 10 | 11 | 01 | 00 | 10 | 11 | 01 | 00 | 01 |
| 10 | 11 | 11 | 00 | 00 | 11 | 11 | 00 | 00 | 11 | 00 | 00 | 10 |
| 11 | 11 | 01 | 00 | 11 | 11 | 01 | 00 | 11 | 11 | 00 | 00 | 01 |
| 12 | 11 | 10 | 00 | 11 | 11 | 10 | 00 | 11 | 11 | 11 | 00 | 00 |
| 13 | 11 | 01 | 00 | 01 | 11 | 01 | 00 | 01 | 11 | 10 | 00 | 01 |
| 14 | 11 | 01 | 00 | 01 | 11 | 01 | 00 | 01 | 11 | 11 | 00 | 11 |

5.3.3.4 Synchronisation Channel (SCH)

The Synchronisation Channel (SCH) is a downlink signal used for cell search. The SCH consists of two sub channels, the Primary and Secondary SCH. The 10 ms radio frames of the Primary and Secondary SCH are divided into 15 slots, each of length 2560 chips. Figure 16 illustrates the structure of the SCH radio frame.

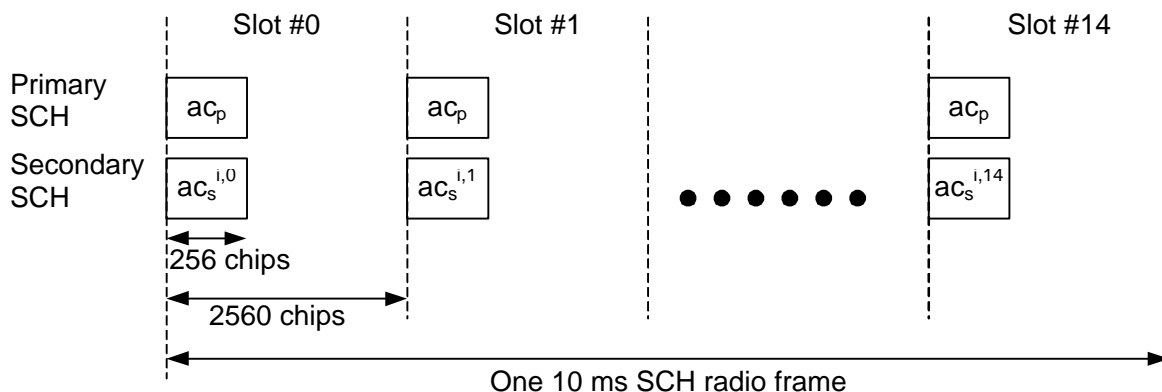

Figure 16: Structure of Synchronisation Channel (SCH)

The Primary SCH consists of a modulated code of length 256 chips, the Primary Synchronisation Code (PSC) denoted c_p in figure 16, transmitted once every slot. The PSC is the same for every cell in the system.

The Secondary SCH consists of repeatedly transmitting a length 15 sequence of modulated codes of length 256 chips, the Secondary Synchronisation Codes (SSC), transmitted in parallel with the Primary SCH. The SSC is denoted $c_s^{i,k}$ in figure 17, where $i = 1, 2, \dots, 64$ is the number of the scrambling code group, and $k = 0, 1, \dots, 14$ is the slot number. Each SSC is chosen from a set of 16 different codes of length 256. This sequence on the Secondary SCH indicates which of the code groups the cell's downlink scrambling code belongs to.

The primary and secondary synchronization codes are modulated by the symbol a shown in figure 17, which indicates the presence/ absence of STTD encoding on the P-CCPCH and is given by the following table:

| | |
|--------------------------|----------|
| P-CCPCH STTD encoded | $a = +1$ |
| P-CCPCH not STTD encoded | $a = -1$ |

5.3.3.4.1 SCH transmitted by TSTD

Figure 17 illustrates the structure of the SCH transmitted by the TSTD scheme. In even numbered slots both PSC and SSC are transmitted on antenna 1, and in odd numbered slots both PSC and SSC are transmitted on antenna 2.

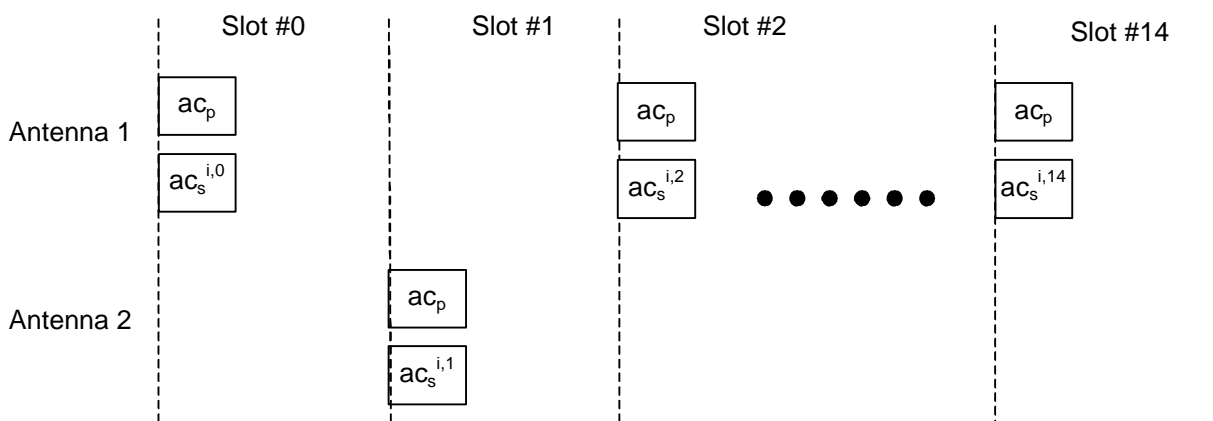

Figure 17: Structure of SCH transmitted by TSTD scheme

5.3.3.5 Physical Downlink Shared Channel (PDSCH)

The Physical Downlink Shared Channel (PDSCH), used to carry the Downlink Shared Channel (DSCH) [transport channel](#), is shared by users based on code multiplexing. As the DSCH is always associated with [one or several](#) DCHs,

the PDSCH is always associated with one or several downlink DPCHs. More exactly, each PDSCH radio frame is associated with one downlink DPCH.

The frame and slot structure of the PDSCH are shown on figure 18.

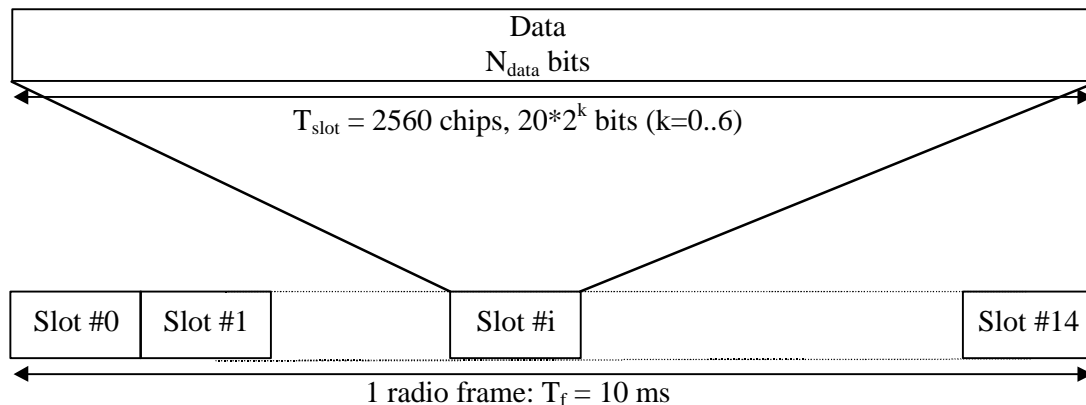

Figure 18: Frame structure for the PDSCH

To indicate for UE that there is data to decode on the DSCH, two signalling methods are possible, either using the TFCI field, or higher layer signalling.

The PDSCH transmission with associated DPCH is a special case of multi-code transmission. The PDSCH and DPCH do not have necessary the same spreading factors. Furthermore, the -and for PDSCH- the spreading factor may vary from frame to frame. All The relevant Layer 1 control information is transmitted on the DPCH part of the associated DPCH, i.e. the PDSCH does not carry contain physical layer information. The channel bit rates and symbol rates for PDSCH are given in table 19.

For PDSCH the allowed spreading factors may vary from 256 to 4.

If the spreading factor and other physical layer parameters can vary on a frame-by-frame basis, the TFCI shall be used to inform the UE what are the instantaneous parameters of PDSCH including the channelisation code from the PDSCH OVSF code tree.

A DSCH may be mapped to multiple parallel PDSCHs, as well, as negotiated at higher layer prior to starting data transmission. In such a case the parallel PDSCHs shall be operated with frame synchronization between each other.

Table 19: PDSCH fields

| Slot format #i | Channel Bit Rate (kbps) | Channel Symbol Rate (ksps) | SF | Bits/ Frame | Bits/ Slot | N _{data} |
|----------------|-------------------------|----------------------------|-----|-------------|------------|-------------------|
| 0 | 30 | 15 | 256 | 300 | 20 | 20 |
| 1 | 60 | 30 | 128 | 600 | 40 | 40 |
| 2 | 120 | 60 | 64 | 1200 | 80 | 80 |
| 3 | 240 | 120 | 32 | 2400 | 160 | 160 |
| 4 | 480 | 240 | 16 | 4800 | 320 | 320 |
| 5 | 960 | 480 | 8 | 9600 | 640 | 640 |
| 6 | 1920 | 960 | 4 | 19200 | 1280 | 1280 |

When open loop transmit diversity is employed for the PDSCH, STTD encoding is used on the data bits as described in section 5.3.1.1.1.

5.3.3.6 Acquisition Indicator Channel (AICH)

The Acquisition Indicator channel (AICH) is a physical channel used to carry Acquisition Indicators (AI). Acquisition Indicator AI_s corresponds to signature s on the PRACH or PCPCH. Note that for PCPCH, the AICH either corresponds

to an access preamble or a CD preamble. The AICH corresponding to the access preamble is an AP-AICH and the AICH corresponding to the CD preamble is a CD-AICH. The AP-AICH and CD-AICH use different channelization codes, see further[4], Section 4.3.3.2.

Figure 19 illustrates the structure of the AICH. The AICH consists of a repeated sequence of 15 consecutive *access slots* (AS), each of length 40 bit intervals. Each access slot consists of two parts, an *Acquisition-Indicator* (AI) part consisting of 32 real-valued symbols a_0, \dots, a_{31} and an unused part consisting of 8 real-valued symbols a_{32}, \dots, a_{39} .

The phase reference for the AICH is the Primary CPICH.

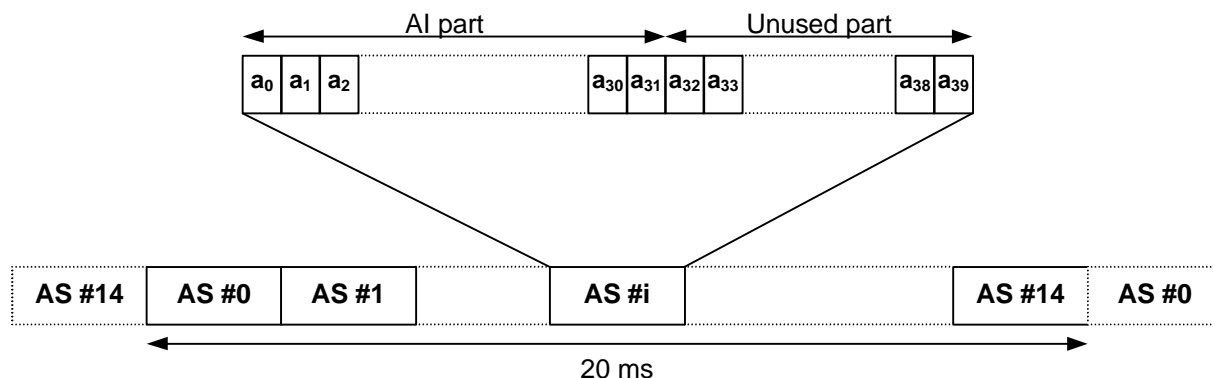

Figure 19: Structure of Acquisition Indicator Channel (AICH)

The real-valued symbols a_0, a_1, \dots, a_{31} in Figure 19 are given by

$$a_j = \sum_{s=0}^{15} AI_s b_{s,j}$$

where AI_s , taking the values +1, -1, and 0, is the acquisition indicator corresponding to signature s and the sequence $b_{s,0}, \dots, b_{s,31}$ is given by Table 20.

The real-valued symbols $a_{32}, a_{33}, \dots, a_{39}$ in Figure 19 are undefined.

In case STTD-based open-loop transmit diversity is applied to AICH, STTD encoding according to section 5.3.1.1.1 is applied to each sequence $b_{s,0}, b_{s,1}, \dots, b_{s,31}$ separately before the sequences are combined into AICH symbols a_0, \dots, a_{31} .

Table 20: AICH signature patterns

| s | $b_{s,0}, b_{s,1}, \dots, b_{s,31}$ |
|----|---------------------------------------------------------------------------------|
| 0 | 1 1 1 1 1 1 1 1 1 1 1 1 1 1 1 1 1 1 1 1 1 1 1 1 1 1 1 1 1 1 1 1 |
| 1 | 1 1 -1 -1 1 1 -1 -1 1 1 -1 -1 1 1 -1 -1 1 1 -1 -1 1 1 -1 -1 1 1 -1 -1 |
| 2 | 1 1 1 1 -1 -1 -1 -1 1 1 1 1 -1 -1 -1 -1 1 1 1 1 -1 -1 -1 -1 1 1 1 1 -1 -1 -1 |
| 3 | 1 1 -1 -1 -1 -1 1 1 1 1 -1 -1 -1 -1 1 1 1 1 -1 -1 -1 -1 1 1 1 1 -1 -1 -1 -1 1 1 |
| 4 | 1 1 1 1 1 1 1 1 -1 -1 -1 -1 -1 -1 -1 -1 1 1 1 1 1 1 1 1 -1 -1 -1 -1 -1 -1 -1 |
| 5 | 1 1 -1 -1 1 1 -1 -1 -1 -1 1 1 -1 -1 1 1 1 1 -1 -1 1 1 -1 -1 -1 -1 1 1 -1 -1 1 1 |
| 6 | 1 1 1 1 -1 -1 -1 -1 -1 -1 -1 -1 1 1 1 1 1 1 1 1 -1 -1 -1 -1 -1 -1 -1 -1 1 1 1 1 |
| 7 | 1 1 -1 -1 -1 -1 1 1 -1 -1 1 1 1 1 -1 -1 1 1 -1 -1 -1 -1 -1 -1 1 1 1 1 1 1 -1 -1 |
| 8 | 1 1 1 1 1 1 1 1 1 1 1 1 1 1 1 1 -1 -1 -1 -1 -1 -1 -1 -1 -1 -1 -1 -1 -1 -1 -1 |
| 9 | 1 1 -1 -1 1 1 -1 -1 1 1 -1 -1 1 1 -1 -1 -1 -1 1 1 -1 -1 1 1 -1 -1 1 1 -1 -1 1 1 |
| 10 | 1 1 1 1 -1 -1 -1 -1 1 1 1 1 -1 -1 -1 -1 -1 -1 -1 -1 1 1 1 1 -1 -1 -1 -1 1 1 1 1 |
| 11 | 1 1 -1 -1 -1 -1 1 1 1 1 -1 -1 -1 -1 1 1 -1 -1 1 1 1 1 -1 -1 -1 -1 1 1 1 1 -1 -1 |
| 12 | 1 1 1 1 1 1 1 1 -1 -1 -1 -1 -1 -1 -1 -1 -1 -1 -1 -1 -1 -1 1 1 1 1 1 1 1 1 1 1 |
| 13 | 1 1 -1 -1 1 1 -1 -1 -1 -1 1 1 -1 -1 1 1 -1 -1 1 1 -1 -1 1 1 1 1 1 1 -1 -1 -1 -1 |
| 14 | 1 1 1 1 -1 -1 -1 -1 -1 -1 -1 -1 1 1 1 1 -1 -1 -1 -1 1 1 1 1 1 1 1 1 -1 -1 -1 -1 |
| 15 | 1 1 -1 -1 -1 -1 1 1 -1 -1 1 1 1 1 -1 -1 -1 -1 1 1 1 1 -1 -1 1 1 -1 -1 -1 -1 1 1 |

5.3.3.7 Paging Indicator Channel (PICH)

The Paging Indicator Channel (PICH) is a fixed rate (SF=256) physical channel used to carry the Paging Indicators (PI). The PICH is always associated with an S-CCPCH to which a PCH transport channel is mapped.

Figure 20 illustrates the frame structure of the PICH. One PICH radio frame of length 10 ms consists of 300 bits (b_0, b_1, \dots, b_{299}). Of these, 288 bits (b_0, b_1, \dots, b_{287}) are used to carry Paging Indicators. The remaining 12 bits ($b_{288}, b_{289}, \dots, b_{299}$) are undefined.

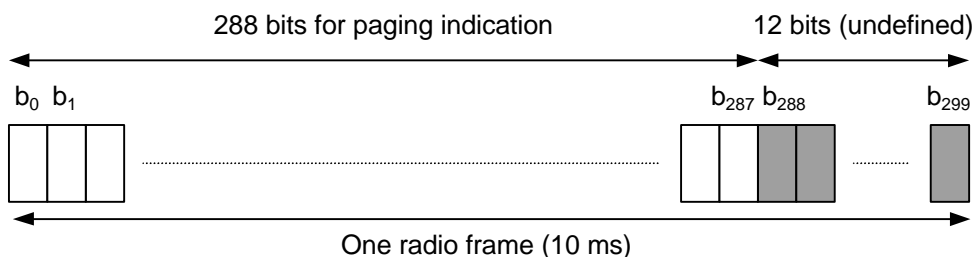

Figure 20: Structure of Paging Indicator Channel (PICH)

N Paging Indicators $\{PI_0, \dots, PI_{N-1}\}$ are transmitted in each PICH frame, where $N=18, 36, 72,$ or 144 .

The PI calculated by higher layers for use for a certain UE, is mapped to the paging indicator PI_p , where p is computed as a function of the PI computed by higher layers, the SFN of the P-CCPCH radio frame during which the start of the PICH radio frame occurs, and the number of paging indicators per frame (N):

$$p = \left(PI + \left[\left((18 \times (SFN + \lfloor SFN / 8 \rfloor) + \lfloor SFN / 64 \rfloor + \lfloor SFN / 512 \rfloor) \bmod 144 \right) \times \frac{N}{144} \right] \right) \bmod N$$

The mapping from $\{PI_0, \dots, PI_{N-1}\}$ to the PICH bits $\{b_0, \dots, b_{287}\}$ are according to table 21.

Table 21: Mapping of Paging Indicators (PI) to PICH bits

| Number of PI per frame (N) | $PI_p = 1$ | $PI_p = 0$ |
|----------------------------|-------------------------------------------------------|-------------------------------------------------------|
| N=18 | $\{b_{16p}, \dots, b_{16p+15}\} = \{1, 1, \dots, 1\}$ | $\{b_{16p}, \dots, b_{16p+15}\} = \{0, 0, \dots, 0\}$ |
| N=36 | $\{b_{8p}, \dots, b_{8p+7}\} = \{1, 1, \dots, 1\}$ | $\{b_{8p}, \dots, b_{8p+7}\} = \{0, 0, \dots, 0\}$ |
| N=72 | $\{b_{4p}, \dots, b_{4p+3}\} = \{1, 1, \dots, 1\}$ | $\{b_{4p}, \dots, b_{4p+3}\} = \{0, 0, \dots, 0\}$ |
| N=144 | $\{b_{2p}, b_{2p+1}\} = \{1, 1\}$ | $\{b_{2p}, b_{2p+1}\} = \{0, 0\}$ |

If a Paging Indicator in a certain frame is set to "1" it is an indication that UEs associated with this Paging Indicator should read the corresponding frame of the associated S-CCPCH.

When transmit diversity is employed for the PICH, STTD encoding is used on the PICH bits as described in section 5.3.1.1.1.

6 Mapping of transport channels onto physical channels

Figure 21 summarises the mapping of transport channels onto physical channels.

Transport Channels**Physical Channels**

| | | |
|-------|-------|-----------------------------------------------------|
| DCH | ————— | Dedicated Physical Data Channel (DPDCH) |
| | | Dedicated Physical Control Channel (DPCCH) |
| RACH | ————— | Physical Random Access Channel (PRACH) |
| CPCH | ————— | Physical Common Packet Channel (PCPCH) |
| | | Common Pilot Channel (CPICH) |
| <hr/> | | |
| BCH | ————— | Primary Common Control Physical Channel (P-CCPCH) |
| FACH | ————— | Secondary Common Control Physical Channel (S-CCPCH) |
| PCH | ————— | |
| | | Synchronisation Channel (SCH) |
| DSCH | ————— | Physical Downlink Shared Channel (PDSCH) |
| | | Acquisition Indication Channel (AICH) |
| | | Page Indication Channel (PICH) |

Transport Channels**Physical Channels**

| | | |
|------|-------|-----------------------------------------------------------------------------|
| DCH | ————— | Dedicated Physical Data Channel (DPDCH) |
| | | Dedicated Physical Control Channel (DPCCH) |
| RACH | ————— | Physical Random Access Channel (PRACH) |
| CPCH | ————— | Physical Common Packet Channel (PCPCH) |
| | | Common Pilot Channel (CPICH) |
| BCH | ————— | Primary Common Control Physical Channel (P-CCPCH) |
| FACH | ————— | Secondary Common Control Physical Channel (S-CCPCH) |
| PCH | ————— | |
| | | Synchronisation Channel (SCH) |
| DSCH | ————— | Physical Downlink Shared Channel (PDSCH) |
| | | Acquisition Indication Channel (AICH) |
| | | <u>Access Preamble Acquisition Indicator Channel (AP-AICH)</u> |
| | | Paging Indication Channel (PICH) |
| | | <u>Collision-Detection/Channel-Assignment Indicator Channel (CD/CA-ICH)</u> |

Figure 21: Transport-channel to physical-channel mapping

The DCHs are coded and multiplexed as described in [3] , and the resulting data stream is mapped sequentially (first-in-first-mapped) directly to the physical channel(s). The mapping of BCH and FACH/PCH is equally straightforward,

where the data stream after coding and interleaving is mapped sequentially to the Primary and Secondary CCPCH respectively. Also for the RACH, the coded and interleaved bits are sequentially mapped to the physical channel, in this case the message part of ~~the random access burst on~~ the PRACH.

7 Timing relationship between physical channels

7.1 General

The P-CCPCH, on which the cell SFN is transmitted, is used as timing reference for all the physical channels, directly for downlink and indirectly for uplink.

Figure 22 below describes the frame timing of the downlink physical channels. For the AICH the access slot timing is included. ~~Transmission T~~iming for uplink physical channels is given by the received timing of downlink physical channels timing, as described in the following sections.

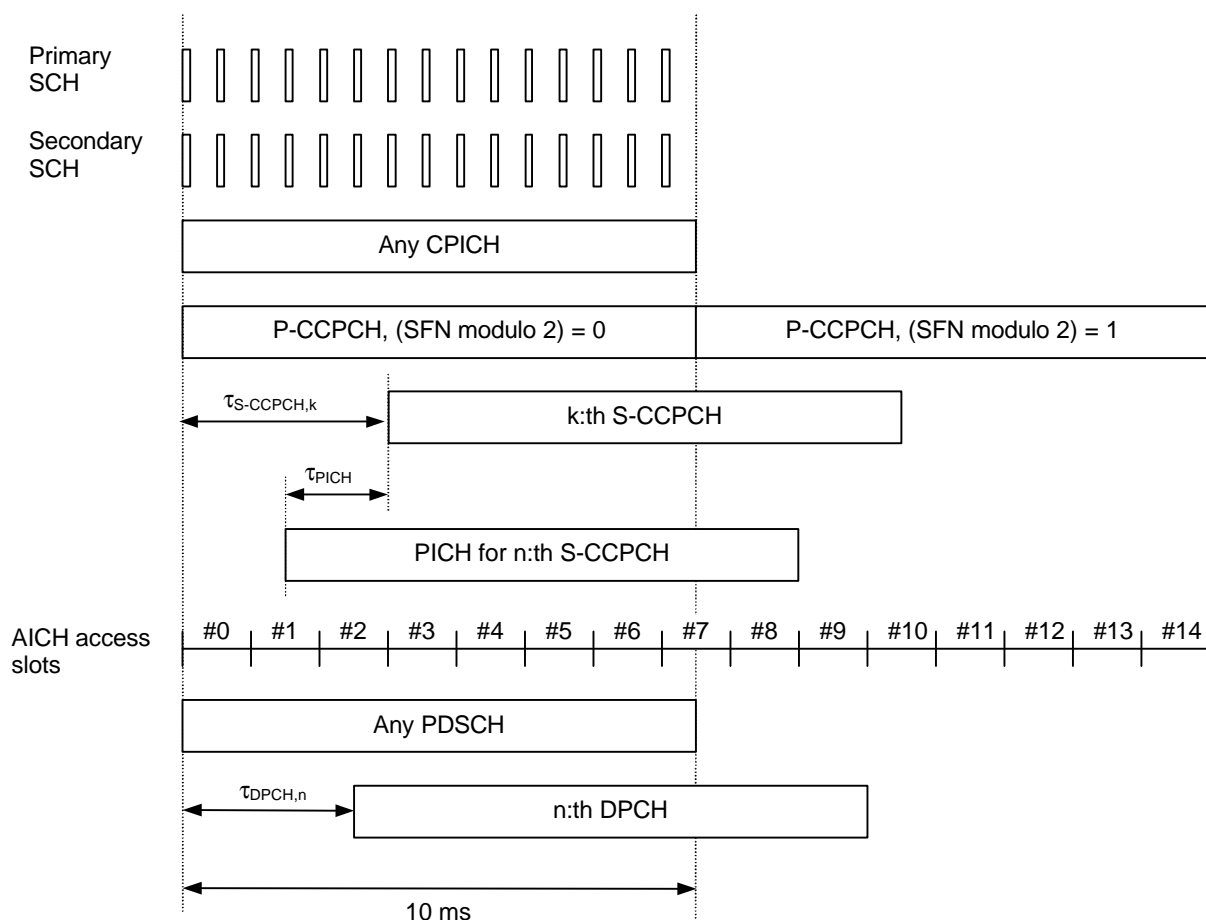

Figure 22: Frame timing and access slot timing of downlink physical channels

~~In figure 22 t~~The following applies:

- SCH (primary and secondary), CPICH (primary and secondary), P-CCPCH, and PDSCH have identical frame timings.
- The S-CCPCH timing may be different for different S-CCPCHs, but the offset from the P-CCPCH frame timing is a multiple of 256 chips, i.e. $\tau_{S-CCPCH,k} = T_k \times 256 \text{ chip}$, $T_k \in \{0, 1, \dots, 149\}$.

- The PICH timing is $\tau_{\text{PICH}} = 7680$ chips prior to its corresponding S-CCPCH frame timing, i.e. the timing of the S-CCPCH carrying the PCH transport channel with the corresponding paging information, see also. The PICH timing relation to the S-CCPCH is described more in section 7.2.
- ~~The~~ AICH access slots #0 starts the same time as ~~a~~ P-CCPCH frames with (SFN modulo 2) = 0. The AICH/PRACH and AICH/PCPCH timing is described in sections 7.3 and 7.4 respectively.
- The relative timing of associated PDSCH ~~timing relative the~~and DPCH ~~timing~~ is described in section 7.5.
- The DPCH timing may be different for different DPCHs, but the offset from the P-CCPCH frame timing is a multiple of 256 chips, i.e. $\tau_{\text{DPCH},n} = T_n \times 256$ chip, $T_n \in \{0, 1, \dots, 149\}$. The DPCH (DPCCH/DPDCH) timing relation with uplink DPCCH/DPDCHs is described in section 7.6.

7.2 PICH/S-CCPCH timing relation

Figure 23 illustrates the timing between a PICH frame and its associated S-CCPCH frame, i.e. the S-CCPCH frame that carries the paging information related to the paging indicators in the PICH frame. A paging indicator set in a PICH frame means that the paging message is transmitted on the PCH in the S-CCPCH frame starting τ_{PICH} chips after the transmitted PICH frame. τ_{PICH} is defined in section 7.1.

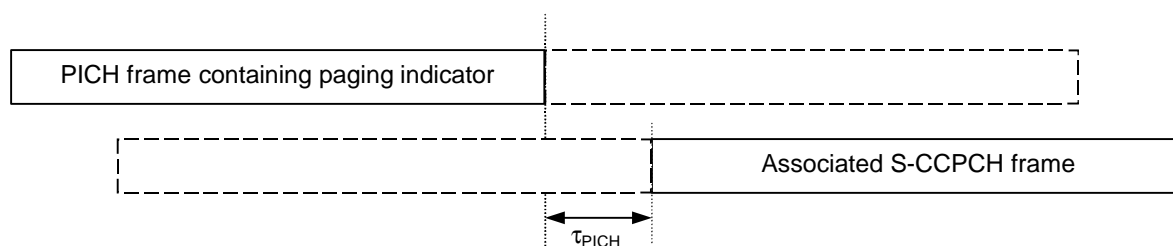

Figure 23: Timing relation between PICH frame and associated S-CCPCH frame

7.3 PRACH/AICH timing relation

The downlink AICH is divided into downlink access slots, each access slot is of length 5120 chips. The downlink access slots are time aligned with the P-CCPCH as described in section 7.1.

The uplink PRACH is divided into uplink access slots, each access slot is of length 5120 chips. Uplink access slot number n is transmitted from the UE $\tau_{\text{p-a}}$ chips prior to the reception of downlink access slot number n , $n = 0, 1, \dots, 14$.

Transmission of downlink acquisition indicators may only start at the beginning of a downlink access slot. Similarly, transmission of uplink RACH preambles and RACH message parts may only start at the beginning of an uplink access slot.

The PRACH/AICH timing relation is shown in figure 24.

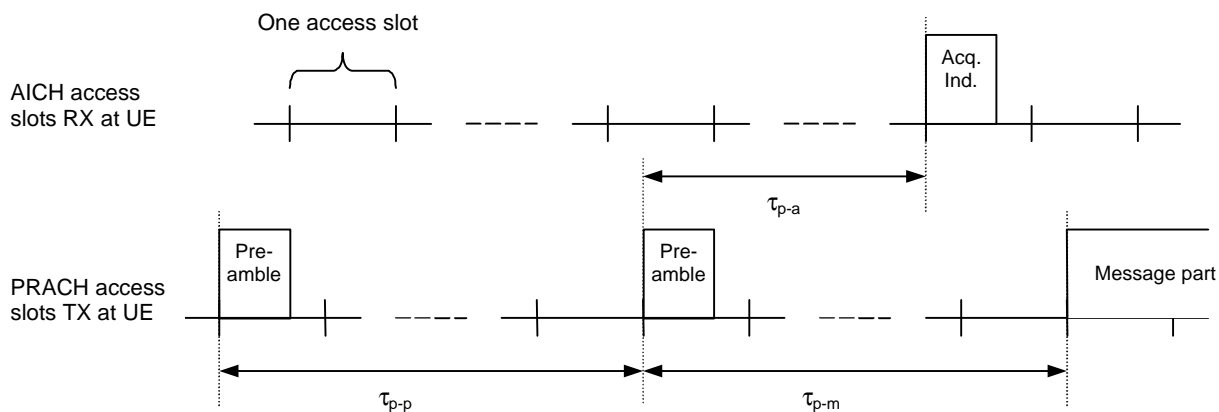

Figure 24: Timing relation between PRACH and AICH as seen at the UE

The preamble-to-preamble distance τ_{p-p} shall be larger than or equal to the minimum preamble-to-preamble distance $\tau_{p-p,min}$, i.e. $\tau_{p-p} \geq \tau_{p-p,min}$.

In addition to $\tau_{p-p,min}$, the preamble-to-AI distance τ_{p-a} and preamble-to-message distance τ_{p-m} are defined as follows:

- when AICH_Transmission_Timing is set to 0, then

$$\tau_{p-p,min} = 15360 \text{ chips (3 access slots)}$$

$$\tau_{p-a} = 7680 \text{ chips}$$

$$\tau_{p-m} = 15360 \text{ chips (3 access slots)}$$

- when AICH_Transmission_Timing is set to 1, then

$$\tau_{p-p,min} = 20480 \text{ chips (4 access slots)}$$

$$\tau_{p-a} = 12800 \text{ chips}$$

$$\tau_{p-m} = 20480 \text{ chips (4 access slots)}$$

The parameter AICH Transmission Timing is signalled by higher layers.

7.4 PCPCH/AICH timing relation

Transmission of random access bursts on the PCPCH is aligned with access slot times. The timing of the access slots is derived from the received Primary CCPCH timing. The transmit timing of access slot n starts $n \times 20/15$ ms after the frame boundary of the received Primary CCPCH, where $n = 0, 1, \dots, 14$. In addition, transmission of access preambles in PCPCH is limited to the allocated access slot subchannel group which is assigned by higher layer signalling to each CPCH set. Twelve access slot subchannels are defined and PCPCH may be allocated all subchannel slots or any subset of the twelve subchannel slots. The access slot subchannel identification is identical to that for the RACH and is described in table 6 of section 6.1 of [5].

Everything in the previous section [PRACH/AICH] applies to this section as well. The timing relationship between preambles, AICH, and the message is the same as PRACH/AICH. Note that the collision resolution preambles follow the access preambles in PCPCH/AICH. However, the timing relationships between CD-Preamble and CD-AICH is identical to RACH Preamble and AICH. The timing relationship between CD-AICH and the Power Control Preamble in CPCH is identical to AICH to message in RACH. The T_{cpch} timing parameter is identical to the PRACH/AICH transmission timing parameter. When T_{cpch} is set to zero or one, the following PCPCH/AICH timing values apply:

Note that a1 corresponds to AP-AICH and a2 corresponds to CD-AICH.

$$\tau_{p-p} = \text{Time to next available access slot, between Access Preambles.}$$

$$\text{Minimum time} = 15360 \text{ chips} + 5120 \text{ chips} \times T_{cpch}$$

Maximum time = 5120 chips X 12 = 61440 chips

Actual time is time to next slot (which meets minimum time criterion) in allocated access slot subchannel group.

- τ_{p-a1} = Time between Access Preamble and AP-AICH has two alternative values: 7680 chips or 12800 chips, depending on T_{cpch}
- τ_{a1-cdp} = Time between receipt of AP-AICH and transmission of the CD Preamble has one value: 7680 chips.
- τ_{p-cdp} = Time between the last AP and CD Preamble. is either 3 or 4 access slots, depending on T_{cpch}
- τ_{cdp-a2} = Time between the CD Preamble and the CD-AICH has two alternative values: 7680 chips or 12800 chips, depending on T_{cpch}
- $\tau_{cdp-pcp}$ = Time between CD Preamble and the start of the Power Control Preamble is either 3 or 4 access slots, depending on T_{cpch} .

Figure 25 illustrates the PCPCH/AICH timing relationship when T_{cpch} is set to 0 and all access slot subchannels are available for PCPCH.

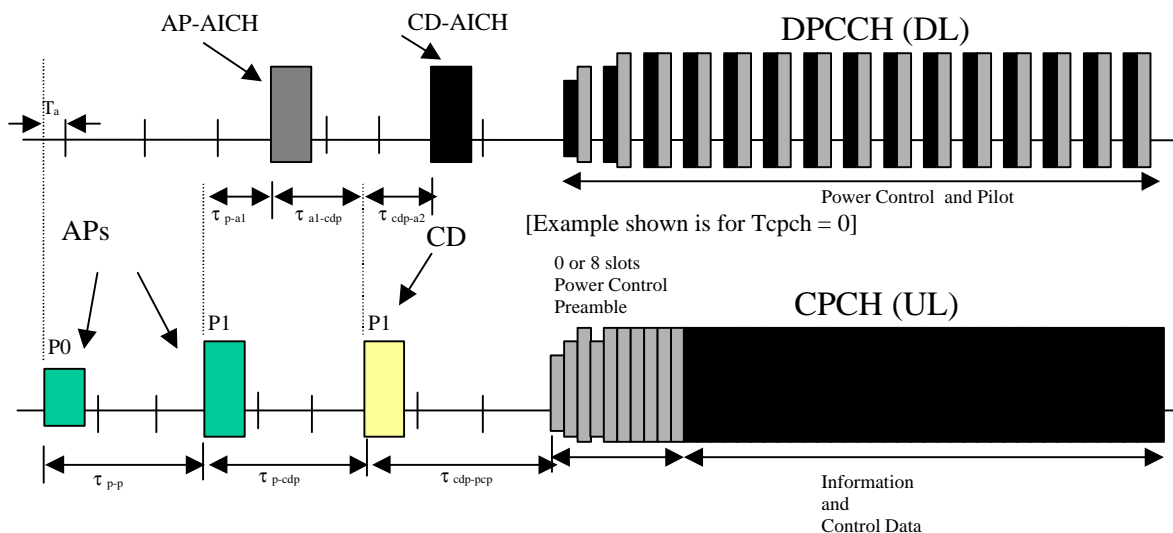

Figure 25: Timing of PCPCH and AICH transmission as seen by the UE, with $T_{cpch} = 0$

7.5 DPCH/PDSCH timing

The relative timing between a DPCH frame and the associated PDSCH frame is shown in figure 26.

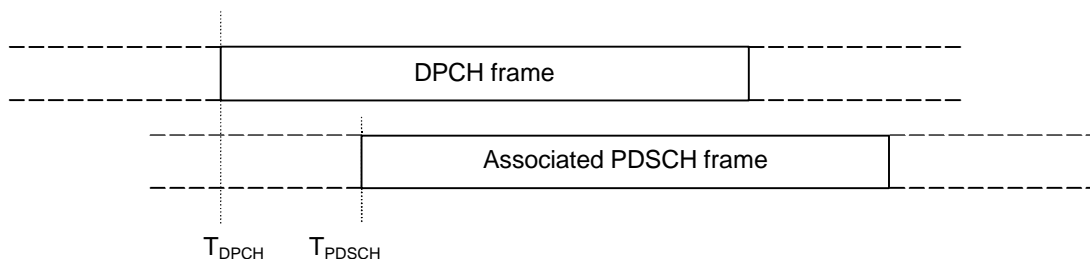

Figure 26: Timing relation between DPCH frame and associated PDSCH frame

The start of a DPCH frame is denoted T_{DPCH} and the start of the associated PDSCH frame is denoted T_{PDSCH} . Any DPCH frame is associated to one PDSCH frame through the relation $-35840 \text{ chips} < T_{\text{DPCH}} - T_{\text{PDSCH}} \leq 2560 \text{ chips}$, i.e. the associated PDSCH frame starts anywhere between 1 slot before or up to 14 slots behind the DPCH.

7.6 DPCCH/DPDCH timing relations

7.6.1 Uplink

In uplink the DPCCH and all the DPDCHs transmitted from one UE have the same frame timing.

7.6.2 Downlink

In downlink, the DPCCH and all the DPDCHs carrying CCTrCHs of dedicated type to one UE have the same frame timing.

7.6.3 Uplink/downlink timing at UE

At the UE, the uplink DPCCH/DPDCH frame transmission takes place approximately T_0 chips after the reception of the first significant path of the corresponding downlink DPCCH/DPDCH frame. T_0 is a constant defined to be 1024 chips. More information about the uplink/downlink timing relation and meaning of T_0 can be found in [5].

In case of USTS, the uplink DPCCH/DPDCH frame transmission for Initial synchronization takes place $T_0 + T_{\text{INIT_SYNC}}$ after the reception of the first significant path of the corresponding downlink DPCCH/DPDCH frame where $T_{\text{INIT_SYNC}}$ is Initial synchronization time delivered by UTRAN. However the uplink DPCCH/DPDCH frame transmission for Tracking of USTS takes place approximately $T_0 + T_{\text{INIT_SYNC}} \pm \delta T$ after the reception of the first significant path of the corresponding downlink DPCCH/DPDCH frame where δT is the resultant timing adjustment due to the timing control by TAB command bits. More information on $T_{\text{INIT_SYNC}}$ and δT can be found in section 9.2 and 9.3 of [5].

7.7 Timing relations for initialisation of channels

Figure 27 shows the timing relationships between the physical channels involved in the initialisation of a DCH.

The maximum time permitted for the UE to decode the relevant FACH frame before the first frame of the DPCCH is received shall be $T_{\text{B-min}} = 38400$ chips (i.e.15 slots).

The downlink DPCCH shall commence at a time T_{B} after the end of the relevant FACH frame, where $T_{\text{B}} \geq T_{\text{B-min}}$ according to the following equation:

$$T_{\text{B}} = (T_{\text{n}} - T_{\text{k}}) \times 256 - N_{\text{pcp}} \times 2560 + N_{\text{offset_1}} \times 38400 \text{ chips}, \text{ where:}$$

N_{pcp} is a higher layer parameter set by the network, and represents the length (in slots) of the power control preamble (see [5], section 5.1.2.4).

$N_{\text{offset_1}}$ is a parameter derived from the activation time set by higher layers. In order that $T_{\text{B}} \geq T_{\text{B-min}}$, $N_{\text{offset_1}}$ shall be an integer number of frames such that:

$$N_{\text{offset_1}} \geq \begin{cases} 1 & \text{when } T_{\text{n}} - T_{\text{k}} \geq \frac{T_{\text{B-min}}}{256} + 10N_{\text{pcp}} - 150 \\ 2 & \text{when } \frac{T_{\text{B-min}}}{256} + 10N_{\text{pcp}} - 300 \leq T_{\text{n}} - T_{\text{k}} < \frac{T_{\text{B-min}}}{256} + 10N_{\text{pcp}} - 150 \\ 3 & \text{when } T_{\text{n}} - T_{\text{k}} < \frac{T_{\text{B-min}}}{256} + 10N_{\text{pcp}} - 300 \end{cases}$$

T_n and T_k are parameters defining the timing of the frame boundaries on the DL DPCCH and S-CCPCH respectively (see section 7.1). These parameters are provided by higher layers.

The uplink DPCCH shall commence at a time T_C after the end of the relevant FACH frame, where

$T_C = T_B + T_0 + N_{offset_2} \times 38400$ chips, where T_0 is as in section 7.6.3 and N_{offset_2} is a UE-specific higher-layer parameter which shall be an integer number of frames greater than or equal to zero.

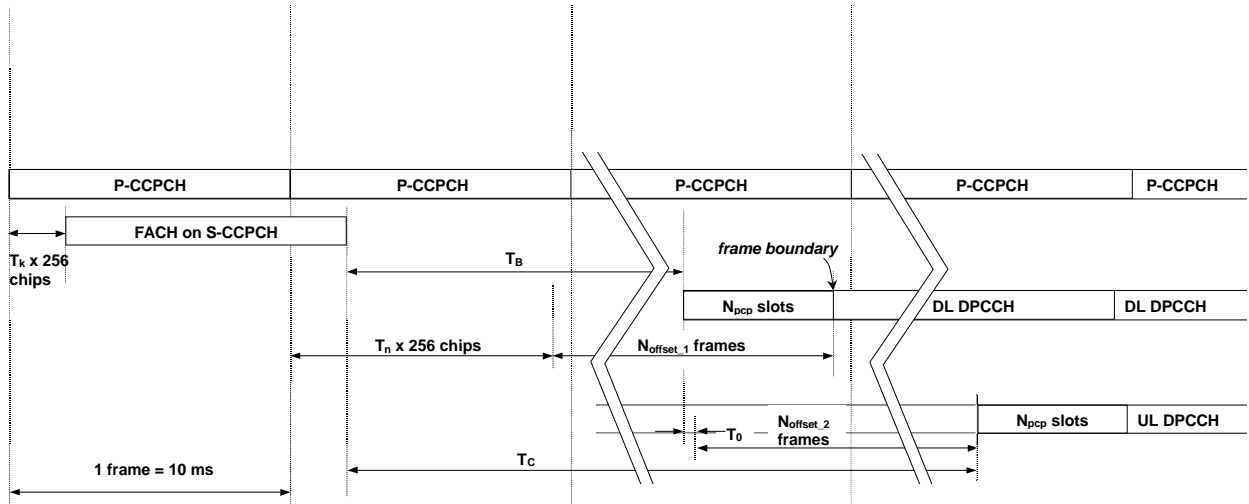

Figure 27: Timing for initialisation of DCH.

The data channels shall not commence before the end of the power control preamble.