

Presentation of Specification to TSG or WG

Presentation to: TSG RAN Meeting #27
Document for presentation: TR 25.804, Version 2.0.0
Presented for: Information

Abstract of document:

TR 25.804 for SI for enhancements for Uplink enhancements for UTRA TDD. The TR describes techniques for potential enhancements

Changes since last presentation to TSG RAN:

Text on Inclusion of 8-PSK

Text on Node-B scheduling

Text on RAN2 impacts

Text on Conclusions and Recommendations

Outstanding Issues:

None

Contentious Issues:

None identified so far

3GPP TR 25.804 V2.0.0 (2005-2)

Technical Report

3rd Generation Partnership Project; Technical Specification Group Radio Access Network; Feasibility Study on Uplink Enhancements for UTRA TDD; (Release 6)



The present document has been developed within the 3rd Generation Partnership Project (3GPP™) and may be further elaborated for the purposes of 3GPP.

The present document has not been subject to any approval process by the 3GPP Organizational Partners and shall not be implemented. This Specification is provided for future development work within 3GPP only. The Organizational Partners accept no liability for any use of this Specification. Specifications and reports for implementation of the 3GPP™ system should be obtained via the 3GPP Organizational Partners' Publications Offices.

Keywords

UMTS, radio, packet mode, layer 1

3GPP

Postal address

3GPP support office address

650 Route des Lucioles - Sophia Antipolis
Valbonne - FRANCE
Tel.: +33 4 92 94 42 00 Fax: +33 4 93 65 47 16

Internet

<http://www.3gpp.org>

Copyright Notification

No part may be reproduced except as authorized by written permission.
The copyright and the foregoing restriction extend to reproduction in all media.

© 2004, 3GPP Organizational Partners (ARIB, CCSA, ETSI, ATIS, TTA, TTC).
All rights reserved.

Contents

Foreword.....	6
Introduction.....	6
1 Scope	7
2 References	7
3 Definitions, symbols and abbreviations.....	8
4 Requirements.....	9
5 Reference Techniques in Earlier 3GPP Releases	9
5.0 Connection State Model	9
5.1 Allocation of Dedicated Resources	10
5.1.1 Uplink/Downlink Synchronization.....	10
5.2 Allocation of Shared Resources	12
5.2.1 General	12
5.2.2 Measurements used for Scheduling.....	12
5.2.3 PUSCH Capacity Request Message	12
5.2.4 Physical Shared Channel Allocation Message	13
5.3 Uplink TFCS Management with RRC Signalling	14
5.4 Transport Format Combination Selection in the UE	15
5.4.1 Description of TFC selection method.....	15
5.4.1.1 TFC selection in UE for 3.84 Mcps TDD option	17
5.4.1.2 TFC selection in UE for 1.28 Mcps TDD option	18

5.4.2	TFC selection method as a reference case for Enhanced Uplink	18
5.5	Uplink Power Control.....	19
5.5.1	3.84 Mcps TDD	19
5.5.2	1.28 Mcps TDD	20
6	Overview of considered Uplink Enhancements for UTRA TDD.....	21
6.1	Scheduling <Node B controlled scheduling, AMC>.....	21
6.1.1	Node-B Rate Scheduling	21
6.1.2	Node-B Physical Resource Scheduling	23
6.1.3	Higher-Order Modulation.....	23
6.2	Hybrid ARQ	23
6.2.1	General	23
6.2.2	Transport Channel Processing	24
6.2.3	Associated Signalling	25
6.3	Fast Allocation of Dedicated or Shared Resources	25
6.4	Signalling.....	25
6.5	Physical Layer Enhancements	25
6.5.1	Open-Loop-Assisted TPC Power Control	25
6.5.2	Intra-frame Scrambling Code Hopping	27
7	Physical Layer Structure Alternatives for Uplink Enhancements for UTRA TDD.....	28
7.1	Relationship to existing transport channels	28
7.1.1	Transport Channel Structure.....	28
7.1.1.1	Number of E-UCHs.....	29
7.1.1.2	TTI	30
8	Evaluation of Techniques for Enhanced Uplink.....	30
8.1	Scheduling <Node B controlled scheduling, AMC>.....	30
8.1.1	Performance Evaluation	30
8.1.2	Complexity Evaluation <UE and UTRAN impacts>	34
8.1.3	Downlink Signalling.....	35
8.1.4	Uplink Signalling.....	35
8.1.5	Compatibility with earlier Releases.....	35
8.1.6	8-PSK	35
8.1.6.1	Link Performance.....	35
8.1.6.2	System Performance.....	39
8.1.6.3	Peak to average power ratio	41
8.2	Hybrid ARQ	44
8.2.1	Performance Evaluation	44
8.2.1.1	Hybrid ARQ Link Performance	44
8.2.1.2	Hybrid ARQ Efficiency.....	46

8.2.2	Complexity Evaluation <UE and UTRAN impacts>	48
8.2.3	Downlink Signalling.....	48
8.2.4	Uplink Signalling.....	48
8.2.5	Compatibility with earlier Releases.....	48
8.3	Fast Allocation of Dedicated or Shared Resources	48
8.3.1	Performance Evaluation	48
8.3.2	Complexity Evaluation <UE and UTRAN impacts>	48
8.3.3	Downlink Signalling.....	48
8.3.4	Uplink Signalling.....	48
8.3.5	Compatibility with earlier Releases.....	48
8.4	Physical Layer Enhancements	48
8.4.1	Intra-frame Scrambling Code Hopping	48
8.4.1.1	Performance Evaluation	48
8.4.1.2	Complexity Evaluation.....	50
8.4.1.3	Compatibility with Earlier Releases.....	50
9	Impacts to the Radio Network Protocol Architecture.....	50
9.1	Protocol Model.....	50
9.2	Introduction of new MAC functionality	51
9.2.1	Introduction of an enhanced uplink transport channel (E-UCH).....	51
9.2.2	HARQ functionality	51
9.2.3	Reordering entity	51
9.2.4	Control of Radio Resources.....	51
9.3	RLC	52
9.4	RRC	52
10	Impacts to Iub/Iur Protocols	52
10.1	Impacts on Iub/Iur Application Protocols.....	52
10.2	Impacts on Frame Protocol over Iub/Iur.....	52
11	Conclusions and Recommendations.....	52
11.1	Conclusions	52
11.2	Recommendations	53
	Annex A: Simulation Assumptions and Results.....	55
A.1	Link Simulation Assumptions	55
A.2	Link Simulation Results	55
A.3	System Simulation Assumptions.....	55
A.4	System Simulation Results	55
A.5	Traffic Models.....	55
	Annex B: Change history.....	55

Foreword

This Technical Report has been produced by the 3rd Generation Partnership Project (3GPP).

The contents of the present document are subject to continuing work within the TSG and may change following formal TSG approval. Should the TSG modify the contents of the present document, it will be re-released by the TSG with an identifying change of release date and an increase in version number as follows:

Version x.y.z

where:

- x the first digit:
 - 1 presented to TSG for information;
 - 2 presented to TSG for approval;
 - 3 or greater indicates TSG approved document under change control.
- y the second digit is incremented for all changes of substance, i.e. technical enhancements, corrections, updates, etc.
- z the third digit is incremented when editorial only changes have been incorporated in the document.

Introduction

At the 3GPP TSG RAN #20 meeting, the study item on “Uplink Enhancements for UTRA TDD” was approved [1].

The justification of the study item is that with the growth in IP based services, there is a burgeoning requirement for increasing the coverage and throughput and reducing the delay of the uplink. Applications that could benefit from an enhanced uplink include web browsing, video clips, multimedia messaging and other IP based applications. This study item investigates enhancements that can be applied to UTRA TDD in order to improve the performance for uplink dedicated and shared transport channels.

The study includes, but is not restricted to the following topics related to uplink enhancements for UTRA TDD in order to enhance uplink performance in general or to enhance the uplink performance for background, interactive and streaming based traffic:

- Adaptive modulation and coding
- Hybrid ARQ
- Node B controlled scheduling
- Fast allocation of dedicated and/or shared resources
- Enhancements to uplink dedicated channels
- Enhancements to uplink shared channels
- Physical layer and higher layer signalling mechanisms to support the enhancements

1 Scope

This present document details and compares proposed enhancements to the UTRA TDD uplink in terms of gains and complexity and draws conclusions on future work.

This document is the technical report for the Release 6 study item “Uplink Enhancements for UTRA TDD” [1]. The purpose of this TR is to help TSG RAN WG1 to define and describe the potential enhancements under consideration and compare the benefits of each enhancement with earlier releases for improving the performance of the UTRA TDD uplink, along with the complexity evaluation of each technique. The scope is to either enhance uplink performance in general or to enhance the uplink performance for background, interactive and streaming based traffic.

This activity involves the Radio Access work area of the 3GPP studies and has impacts both on the Mobile Equipment and Access Network of the 3GPP systems.

2 References

The following documents contain provisions that, through reference in this text, constitute provisions of the present document.

- References are either specific (identified by date of publication, edition number, version number, etc.) or non-specific.
- For a specific reference, subsequent revisions do not apply.
- For a non-specific reference, the latest version applies. In the case of a reference to a 3GPP document (including a GSM document), a non-specific reference implicitly refers to the latest version of that document *in the same Release as the present document*.

- [1] 3GPP TSG RAN RP-030359: "Study Item Description for Uplink Enhancements for UTRA TDD".
- [2] 3GPP TS 25.123 V3.13.0 (2003-06), “Requirements for support of radio resource management (TDD)”, June 2003
- [3] TS 25.224, V5.4.0, “Physical layer procedures (TDD)”, June 2003
- [4] TS 25.321 V5.5.0 “Medium Access Control (MAC), Protocol specification, September 2003
- [5] TS 25.331, V5.5.0, "Radio Resource Control (RRC); Protocol Specification", June 2003
- [6] 3GPP TR 25.942 V3.3.0 (2002-06), RF System Scenarios, June 2002.
- [7] 3GPP TR 25.853 V4.0.0 (2001-03), “Delay Budget within the Access Stratum”, March 2001
- [8] ETSI TR 101 12, Universal Mobile Telecommunications System (UMTS); Selection procedures for the choice of radio transmission technologies of the UMTS (UMTS 30.03 V3.2.0)
- [9] 3GPP TR 25.896 “Feasibility Study for Enhanced Uplink for UTRA FDD” v2.0.0
- [10] TS 25.223, V5.3.0, “Spreading and Modulation (TDD), March 2003
- [11] TS 25.309, V6.1.0 “FDD Enhanced Uplink; Overall description; Stage 2 (Release 6)”
- [12] TS 25.433, V6.4.0 “UTRAN Iub Interface NBAP Signalling”
- [13] TS 25.423, V6.4.1 “UTRAN Iur Interface RNSAP Signalling

3 Definitions, symbols and abbreviations

E-DCH	Enhanced DCH, a new dedicated transport channel type or enhancements to an existing dedicated transport channel type (if required by a particular proposal)
E-DPCH	Enhanced DPCH, a new physical channel or enhancements to the current DPCH (if required by a particular proposal)

4 Requirements

- The overall goal is to improve the coverage and throughput as well as to reduce the delay of the uplink dedicated and common transport channels.
- The focus shall be on urban, sub-urban and rural deployment scenarios. Uplink enhancements should be optimised for low-speed to medium-speed scenarios, but high-speed scenarios should also be supported.
- The study shall investigate the possibilities to enhance the uplink performance in general, with priority to streaming, interactive and background services.
- Features or group of features should demonstrate significant incremental gain, with reasonable complexity. The value added per feature should be considered in the evaluation.
- The UE and network complexity shall be minimised for a given level of system performance.
- The impact on current releases in terms of both protocol and hardware perspectives shall be taken into account.
- Enhancements shall either improve uplink performance for dedicated channels or for common channels or for both dedicated and common channels.
- Enhancements shall improve uplink performance for at least one of the UTRA TDD modes. Provided that system performance and complexity are not unduly impacted and that an enhancement is applicable to the UTRA mode under consideration, commonality between the UTRA modes (1.28Mcps TDD, 3.84 Mcps TDD and FDD) should be maintained. Inability to support an enhancement in one TDD mode shall not preclude its consideration for the other mode.
- It shall be possible to introduce the new features in a network which has terminals from Release'99, Release 4 or Release 5.

5 Reference Techniques in Earlier 3GPP Releases

5.0 Connection State Model

A fundamental concept in WCDMA is the connection state model, illustrated in Figure 5.0.1. The connection state model enables optimization of radio and hardware resources depending on the activity level of each UE and / or the traffic type of the service provided.

Both UTRA FDD and TDD modes provide support for Dedicated Channels and as an option support the DL Shared Channel. In addition, UTRA TDD modes as an option provide support for the UL Shared Channel. Similar to the DL Shared Channels in UTRA FDD and TDD modes, support of the UL Shared Channel in UTRA TDD is indicated by the UE capability signalling.

When there is high transmission activity (in either uplink, downlink or both), the RRC connection state may be either CELL_DCH or depending on UE capabilities CELL_FACH state. The choice of state depends on a variety of factors including transmission activity level, traffic type, need for dedicated channels and implementation:

- When dedicated channels are used, the UE must be in CELL_DCH state, where power-controlled dedicated channels are established to/from the UE. In CELL_DCH state, the UE is assigned dedicated radio and hardware resources. Depending on UE capability, the UE may be allocated shared resources in addition to dedicated resources in CELL_DCH state.
- When dedicated channels are not used, but there is transmission activity, the UE should be in CELL_FACH state, where only common channels are used. In CELL_FACH state, no dedicated hardware resources in the Node B are needed.
- When there is no transmission activity the UE should be in CELL_PCH or URA_PCH states, which enable very low UE power consumption but do not allow any data transmission. These states are not further discussed in this section.

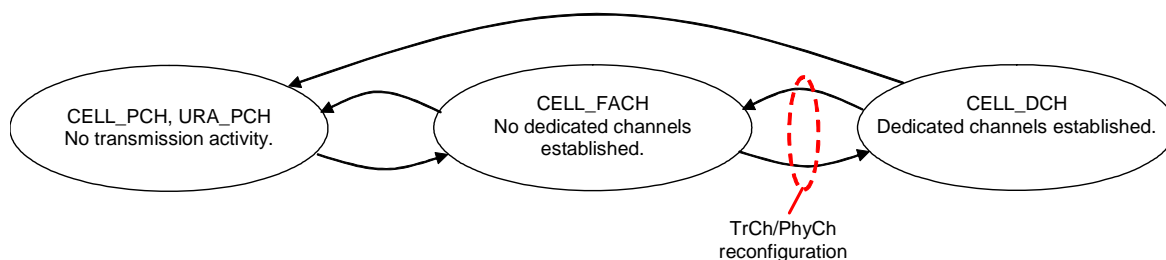

Figure 5.0.1: Connection states

5.1 Allocation of Dedicated Resources

Switching between CELL_DCH and CELL_FACH is controlled by the SRNC with RRC signalling based on requests from either the network or the UE. Entering CELL_DCH implies the establishment of a DCH, which depending on UE capabilities may involve a physical layer random access procedure, NBAP and RRC signalling, and uplink and downlink physical channel synchronization.

Clearly, it is desirable to switch a UE to CELL_FACH state when there is less transmission activity in order to save network resources and to reduce the UE power consumption. Switching between CELL_DCH and CELL_FACH is especially useful in scenarios with a large number of bursty packet data users, where there is a risk that the system becomes resource limited if users temporarily not receiving/transmitting any packets are not switched to CELL_FACH. When the network decides that a DPCH is required (e.g. due to an increase in transmission activity), the UE should rapidly be switched back to CELL_DCH and a dedicated channel is established.

5.1.1 Uplink/Downlink Synchronization

Examples for DCH radio link establishment procedures in Rel99/4/5 are illustrated in Figure 5.11.1 (unsynchronized case) and 5.1.1.2 (synchronized case). At time t_1 , downlink data arrives to the RNC and a decision to establish a DCH is taken at time t_2 . The decision is sent to the UE via the S-CCPCH. The UE starts to establish synchronization to the downlink DPCH at time t_4 using the standardized procedures described in [3]. In case of an unsynchronized radio link establishment procedure, T_3 corresponds to the S-CCPCH reception delay and the RRC procedure performance value. In case of synchronized establishment procedures, t_4 would typically correspond to the designated activation time.

The downlink synchronization procedure is divided into two phases: the first phase starts when higher layers in the UE initiate physical dedicated channel establishment and lasts until 160 ms after the downlink dedicated channel is considered established by higher layers. During this time, out-of-sync shall not be reported and in-sync shall be reported using the CPHY-Sync-IND primitive if any one of the following three criteria is fulfilled.

- The UE estimates the burst reception quality over the previous 40 ms period to be better than a threshold Q_{in} . This criterion shall be assumed not to be fulfilled before 40 ms of burst reception quality measurement have been collected.
- At least one transport block with a CRC attached is received in a TTI ending in the current frame with correct CRC.
- The UE detects at least one Special Burst. Special Burst detection shall be successful if the burst is detected with quality above a threshold, Q_{sbin} , and the TFCI is decoded to be that of the Special Burst.

For dedicated physical channels configured with repetition periods, only the configured active periods shall be taken into account in the estimation. The status check also includes detection of the Special Bursts.

The second phase starts 160 ms after the downlink dedicated channel is considered established by higher layers. During this phase, both out-of-sync and in-sync are reported, depending on the situation in the UE. As the UE is not allowed to report in-sync until at least 10 ms after the start of the first synchronization phase, the interval T_4 equals at least 10 ms.

The UE is allowed to transmit the uplink DPCH independent from the synchronization status of the downlink DPCH, i.e. it can start transmitting the uplink DPCH containing either Special Bursts or at least one transport block with a CRC attached as early as at time t_4 . Upon reception of the uplink DPCH, the Node B establishes synchronization with the UE on the uplink.

One possible criteria for the Node B to start transmitting data on the downlink DPCH is successful synchronization, such as shown as example for the case of an unsynchronized establishment procedure at time t_6 in figure 5.1.2. In case of an synchronized establishment procedure, Node B would typically start transmitting data on the downlink DPCH at the designated activation time.

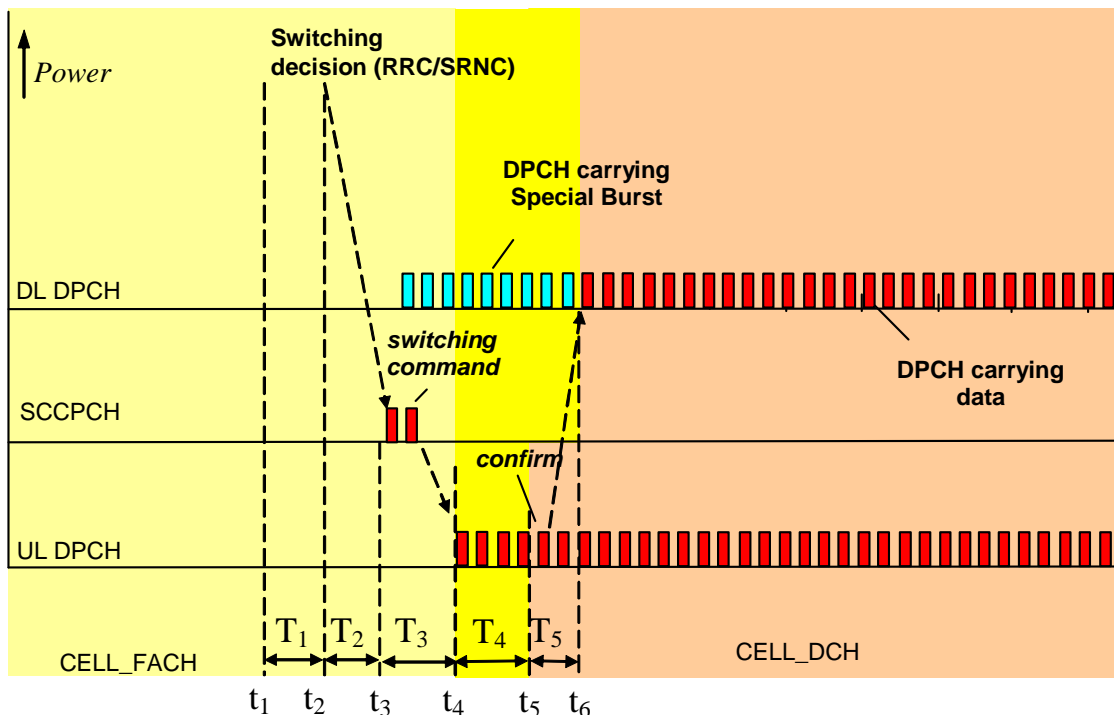

Figure 5.1.1.1: Example for Rel99/4/5 DCH setup with unsynchronized establishment procedure and using Special Bursts

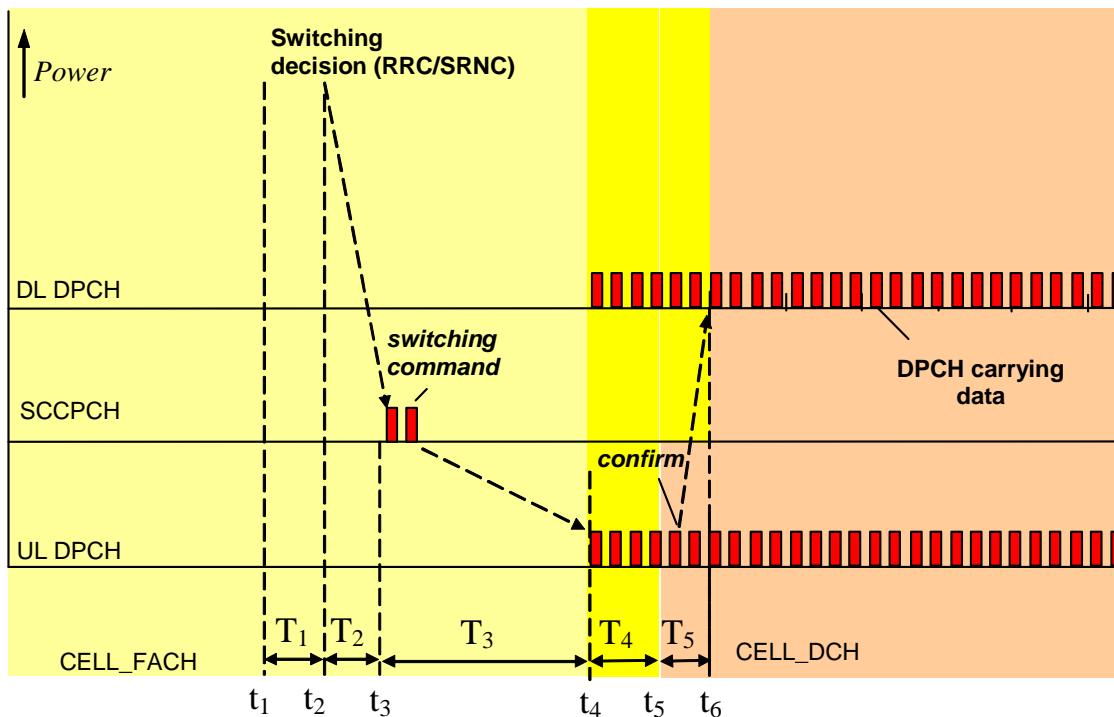

Figure 5.1.1.2: Example for Rel99/4/5 DCH setup with synchronized establishment procedure

Note: the command to switch the UE between CELL_FACH and CELL_DCH may alternatively be transmitted on PDSCH depending to UE capability.

5.2 Allocation of Shared Resources

5.2.1 General

The Uplink Shared Channel in UTRA TDD allows for an arbitrated dynamic allocation of physical resources amongst UE's requesting PUSCH resource for uplink transmission of data.

When using USCH the techniques of TFCS selection by RRC signalling and TFC selection by the UE apply to the same degree as they do for UL DCH operation – see relevant sections 5.3 and 5.4. However, in respect of section 5.3 it is noted that the UL TFCS may be changed within the allocation message itself without the need for a Physical Channel Reconfiguration message as is required in the case of DCH.

The use of USCH does not require DCH/DPCH and as such may be operated in either Cell_DCH or Cell_FACH state.

Allocation of PUSCH resources is under the control of the CRNC.

5.2.2 Measurements used for Scheduling

The decision to allocate resource, and how much, to a UE is typically (but not exclusively) based upon traffic volume measurements (TVM) received from the UE. In general a TVM instance may be configured by UTRAN for transport channels of type DCH or USCH. However, when a TVM is configured in the UE by UTRAN for a transport channel of type USCH, the resulting report will be returned within a PUSCH Capacity Request message. (as opposed to within a Measurement Report message as is the case for DCH TVM).

The TVM is instantiated by UTRAN either via a measurement control message sent via dedicated signalling (configuring triggered or periodic TVM reports), or via system information broadcast. In the case of triggered reporting, the report trigger is based upon Transport Channel Traffic Volume (TCTV). TCTV is the aggregate traffic volume on all UL radio bearers mapped to the specific (USCH) transport channel and the TCTV trigger threshold is configurable and controllable by UTRAN.

The TVM report itself may contain instantaneous and mean RLC buffer volume in addition to RLC buffer variance. It is reported on a per radio bearer basis. The volume itself is expressed in bytes and is enumerated by 20 discrete values within the message within the range 0 to 1024kBytes.

UTRAN may also control whether the PUSCH Capacity Request message carries additional measurement information from UE to UTRAN including P-CCPCH RSCP and DL timeslot ISCP (although it is unlikely that the latter would be used for UL scheduling).

In addition to the aforementioned measurements it is possible that other RRC measurement reports may be used by UTRAN to assist with the scheduling process. However, this depends on the RRC connected state in which the UE is residing, as the availability of RRC measurements from the UE is linked to the RRC state (cell_FACH / cell_DCH). TVM reports are however available in both cell_FACH and cell_DCH state.

Regardless of RRC state, measurement information from Node-B may also be used by UTRAN to assist with the scheduling process, such as UL timeslot ISCP.

5.2.3 PUSCH Capacity Request Message

A PUSCH Capacity Request message will be triggered by the UE in the event that the configured TCTV threshold has been exceeded (reporting event 4a in [5]). UTRAN may configure timers T310 and T311 and counter value N310 within the UE to control the persistence of PUSCH Capacity Request message transmissions in the case that no corresponding PUSCH allocation has been granted.

The message itself contains the TVM per radio bearer and may additionally carry the DSCH-RNTI UE identifier, P-CCPCH RSCP and DL timeslot ISCP measurement reports.

The PUSCH Capacity Request message may be transmitted on RACH or USCH, but not on DCH. This is due to the message being mapped to the SHCCH logical channel which cannot be mapped to DCH (the mapping of SHCCH to transport channels is fixed and is defined in section 13.6a of [5]). SHCCH is always terminated by the CRNC and is not extendable across I_{ur} . Hence the entity in control of allocation of PUSCH resources resides in the CRNC. When the message is sent on RACH, the DSCH-RNTI is used for UE identification purposes.

5.2.4 Physical Shared Channel Allocation Message

In response to TVM reports received from the UE the CRNC may decide to allocate PUSCH resources to that UE. Allocation of PUSCH resource is signaled to the UE via the Physical Shared Channel Allocation Message (PSCHAM) which is mapped either to SHCCH (in which case the DSCH-RNTI is used for identification purposes) or to DCCH. The message may thus be conveyed using FACH, DCH, or DSCH. Note that the mapping of PSCHAM to DCCH is only possible when CRNC and SRNC are coincident.

The PSCHAM allows for the fast reconfiguration of the resources available to the UE and may be thought of as a fast Physical Channel Reconfiguration message.

The message may also be used to convey the following additional information to the UE:

- DSCH resource allocation information
- UL timing advance information
- UL power control information (specifically SIR target from the outer-loop entity in RNC)
- Measurement control for P-CCPCH RSCP and DL timeslot ISCP reports from the UE carried via PUSCH Capacity Request.

If the “configuration” IE within the PSCHAM is set to “old”, then the message effectively reallocates some previously configured PUSCH resources. If set to “new” the details of the new PUSCH resources (codes and timeslots) being allocated are extracted from the message by the UE.

Upon receiving allocation of new PUSCH resources via the PSCHAM the UE starts to use these resources at the CFN defined by the “Allocation Activation Time” IE and for the length of time defined in frames by the “Allocation Duration” IE. The Node-B is informed of the PUSCH allocations via the Dynamic PUSCH Assignment FP message over I_{ub} via a ‘tag’ termed “PUSCH set ID”, the activation time and the duration. The Node-B is informed of the PUSCH sets in advance using NBAP signalling.

The UE is responsible for reconfiguring the MAC-c/sh in the event that the allocation of resources causes a restriction in the allowed TFCS subset. In such circumstances some TFC’s are made unavailable for selection by the MAC-c/sh in the UE as a direct result of the L1 resources granted by RRC.

Figure 5.2.1 illustrates the sequence of steps in an uplink transmission on PUSCH. The UE is assumed to be in Cell-FACH state.

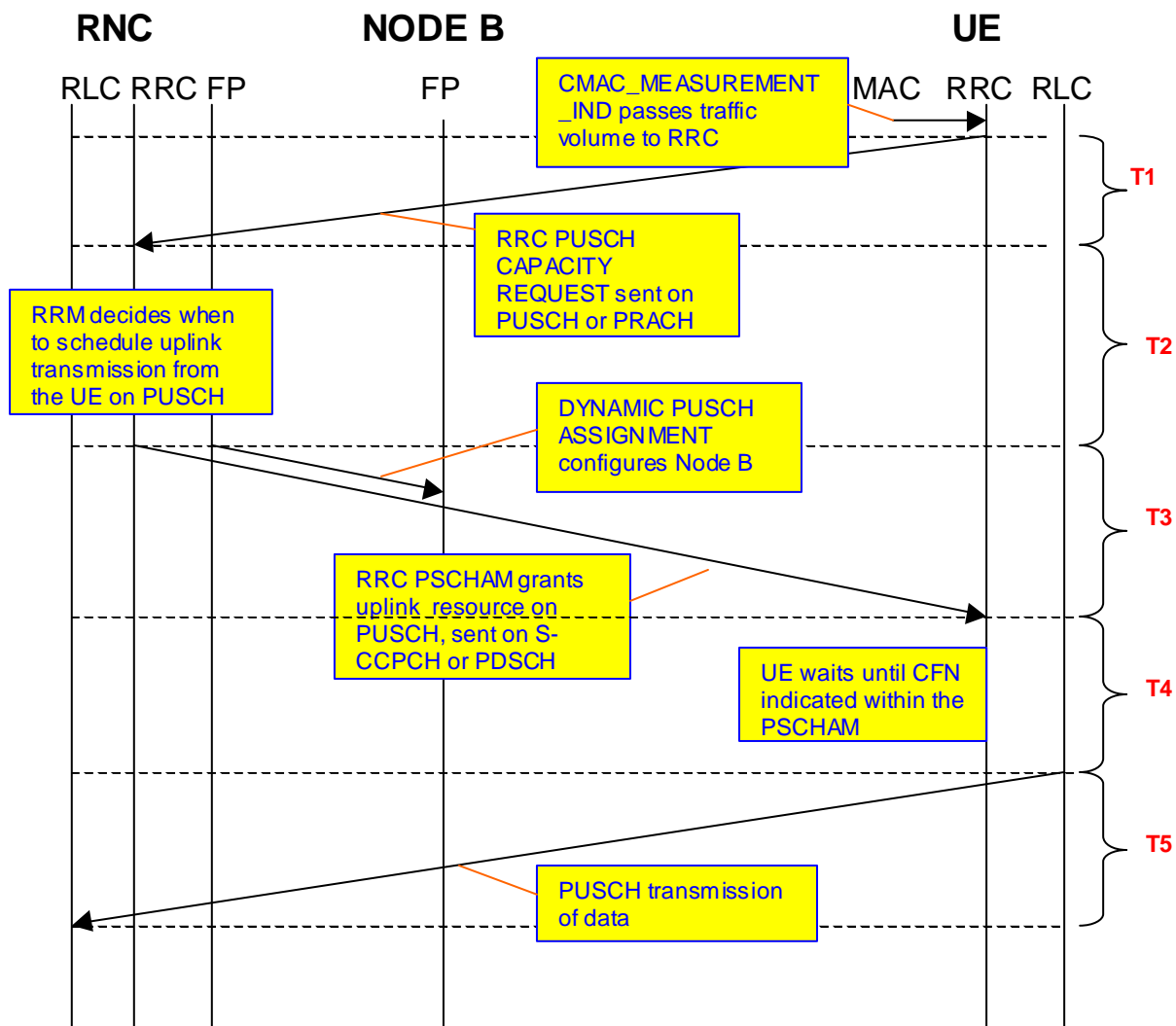

Figure 5.2.1: Message sequences required for uplink transmission on PUSCH.

5.3 Uplink TFCS Management with RRC Signalling

There are following TFCS reconfiguration messages available in current specifications [5]:

- Complete reconfiguration, in which case UE shall remove a previously stored TFCS set, if it exists
- Addition, in which case UE shall insert the new additional TFC(s) into the first available position(s) in ascending order in the TFCS.
- Removal, in which case UE shall remove the TFC indicated by “IE” TFCI from the current TFCS, and regard this position (TFCI) as vacant.
- Replace, in which case UE shall replace the TFCs indicated by “IE” TFCI and replace them with the defined new TFCs.

In addition to those, there is also Transport format combination control message defined in [5], with which the network can define certain restrictions in the earlier defined TFCS set, as described below.

- Transport Format Combination Subset in the TFC control message can be defined in the format of TFCS restriction; for downgrading the original TFCS set. There are several different formats possible. The message can define the minimum allowed TFC index in the original TFCS set. Or it can define that a certain TFC subset

from the original TFCS set is either allowed or not. One possible way to define the message is to list what Transport channels have restrictions, and then list the allowed TFIs for the restricted Transport channels.

- Transport Format Combination Subset in the TFC control message can be defined in the format of cancelling the earlier TFCS restriction; i.e. defining that the original TFCS set is valid again.

Transport format combination control message includes activation time. The activation time defines the frame number /time at which the changes caused by the related message shall take effect. The activation time can be defined as a function of CFN, ranging between 0...255, the default being "now".

Transport format combination control message can also include an optional parameter of TFC control duration, which defines the period in multiples of 10 ms frames for which the defined restriction, i.e. TFC subset, is to be applied. The possible values for this are (1,2,4,8,16,24,32,48,64,128,192,256,512).

In [5], in section 13.5, it is defined separately for each RRC procedure, what kind of delay requirements there are for UE. For TFCS control messages there are following delay requirements:

- TRANSPORT FORMAT COMBINATION CONTROL: $N1 = 5$. This defines the upper limit on the time required to execute modifications in UE after the reception of the RRC message has been completed. This means that after receiving the TFCS control message, the UE shall adopt the changes in the beginning of the next TTI starting after $N1 * 10$ ms.
- TRANSPORT FORMAT COMBINATION CONTROL FAILURE: $N2 = 8$. This defines the number of 10 ms radio frames from end of reception of UTRAN -> UE message on UE physical layer before the transmission of the UE -> UTRAN response message must be ready to start on a transport channel with no access delay other than the TTI alignment. The UE response message transmission from the physical layer shall begin at the latest $(N2 * 10) + TTI$ ms after completion of the reception of the last TTI carrying the triggering UTRAN -> UE message. When Target State is CELL_DCH, the UE response message transmission from the physical layer may be additionally delayed by the value of IE "SRB delay".

The mechanisms for TFCS management described above apply for dedicated and shared channels. However since the CRNC has control of shared channel resources it is also possible to control TFCS for USCH via system information. SIBs 5, 6, and 17 contain shared channel information including the definition of TFCS. SIBs 5 and 6 are value tag controlled SIBs and are therefore likely to be updated slowly. SIB17 is a timer based SIB which is updated regularly (every SIB_REP period [5]). The definition of TFCS in system information for USCH allows for complete reconfiguration, addition, removal or replacement of TFCs within the TFCS.

For dedicated channels the TFCS ID for a CCTrCH may be changed via the "Physical Channel Reconfiguration" message, whereas for shared channels this may be achieved via the "Physical Shared Channel Allocation Message" (PSCHAM).

5.4 Transport Format Combination Selection in the UE

5.4.1 Description of TFC selection method

TFC selection is a MAC function that the UE uses to select a TFC from its current TFCS whenever it has something to transmit. The TFC is selected based on the need for data rate (i.e. UE buffer contents), the currently available transmission power, the available TFCS and the UE's capabilities. The details of the TFC selection function are covered in [2] and [4].

In UTRA TDD, UEs in CELL_DCH state and UEs in CELL_FACH state using the USCH transport channel shall continuously monitor the state of each TFC based on its required transmit power versus the maximum UE transmit power. The maximum UE transmitter power is defined in [2] as follows,

$$\text{Maximum UE transmitter power} = \text{MIN}(\text{Maximum allowed UL TX Power, UE maximum transmit power})$$

where

Maximum allowed UL TX Power is signalled to the UE by UTRAN [5], and

UE maximum transmit power is defined by the UE power class.

The UE therefore continuously evaluates based on the *Elimination*, *Recovery* and *Blocking* criteria defined below, how TFCs on an uplink CCTrCH of DPCH or PUSCH type can be used for the purpose of TFC selection. The following diagram illustrates the state transitions for the state of a given TFC.

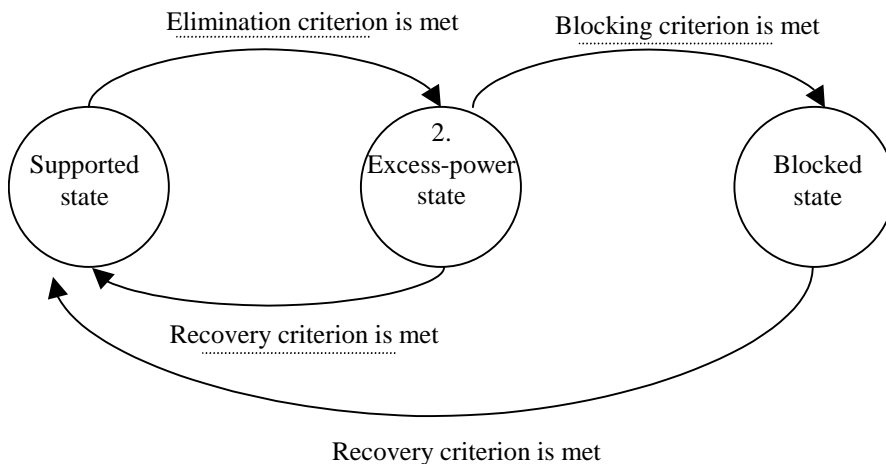

Figure 5.4.1: State transitions for the state of a given TFC

Before selecting a TFC, i.e. at every boundary of the shortest TTI, the set of valid TFCs shall be established. All TFCs in the set of valid TFCs shall:

1. belong to the TFCS.
2. not be in the Blocked state.
3. be compatible with the RLC configuration.
4. not require RLC to produce padding PDUs
5. not carry more bits than can be transmitted in a TTI

The UE may remove from the set of valid TFCs, TFCs in Excess-power state in order to maintain the quality of service for sensitive applications (e.g. speech).

The chosen TFC shall be selected from within the set of valid TFCs and shall satisfy the following criteria in the order in which they are listed below:

1. No other TFC shall allow the transmission of more highest priority data than the chosen TFC.
2. No other TFC shall allow the transmission of more data from the next lower priority logical channels. Apply this criterion recursively for the remaining priority levels.
3. No other TFC shall have a lower bit rate than the chosen TFC.

UE shall consider that the Blocking criterion is never met for TFCs included in the minimum set of TFCs (see [4]).

For 3.84 Mcps UTRA TDD, the evaluation of the *Elimination*, *Recovery* and *Blocking* criteria shall be performed using the estimated UE transmit power of a given CCTrCH in its associated timeslots.

For 1.28 Mcps UTRA TDD, the evaluation of the *Elimination*, *Recovery* and *Blocking* criteria shall be performed using the estimated UE transmit power of a given TFC. The UE transmit power estimation shall be made using the UE transmitted power measured over the measurement period and the gain factors of the corresponding TFC.

The measurement period of the UE transmitted power measurement is defined in section 9.1.2.1 of [2] as one timeslot. Table 5.4.2 below, extracted from [2], shows the specified accuracy requirements for measuring UE transmit power as a function of the current transmit power level relative to maximum output power.

Table: 5.4.2 - UE transmitted power absolute accuracy

Parameter	Unit	Accuracy [dB]
-----------	------	---------------

		PUEMAX 24dBm	PUEMAX 21dBm
UE transmitted power=PUEMAX	dBm	+1/-3	±2
UE transmitted power=PUEMAX-1	dBm	+1.5/-3.5	±2.5
UE transmitted power=PUEMAX-2	dBm	+2/-4	±3
UE transmitted power=PUEMAX-3	dBm	+2.5/-4.5	±3.5
PUEMAX-10≤UE transmitted power<PUEMAX-3	dBm	+3/-5	±4

NOTE 1: User equipment maximum output power, PUEMAX, is the maximum output power level without tolerance defined for the power class of the UE in 3GPP TS 25.102 "UTRA (UE) TDD; Radio Transmission and Reception".

5.4.1.1 TFC selection in UE for 3.84 Mcps TDD option

In the case of a single CCTrCH or multiple CCTrCHs having mutually exclusive timeslot assignments, the UE shall consider the *Elimination* criterion for a given TFC of a CCTrCH to be fulfilled if for 3 successive frames the estimated UE transmit power is greater than the Maximum UE transmitter power for at least one timeslot associated with the CCTrCH in each frame. In the case of multiple CCTrCHs not having mutually exclusive timeslot assignments, if for a given CCTrCH for 3 successive frames the estimated UE transmit power is greater than the Maximum UE transmitter power for at least one timeslot associated with the CCTrCH in each frame, the UE shall consider the *Elimination* criterion for a given TFC to be fulfilled if the use of this TFC will cause the estimated UE transmit power to continue to be greater than the Maximum UE transmitter power in at least one timeslot associated with the CCTrCH. In the case of multi-frame operation of UL Physical Channels, the UE shall only consider active frames for the evaluation of the *Elimination* criterion. The MAC in the UE shall consider that the TFC is in Excess-Power state for the purpose of TFC selection.

MAC in the UE shall indicate the available bitrate for each logical channel to upper layers within T_{notify} from the moment the *Elimination* criterion was detected.

The UE shall not consider the *Recovery* criterion for a given TFC to be fulfilled until the use of this TFC will not cause the estimated UE transmit power to be greater than the Maximum UE transmitter power for all UL timeslots associated with the TFC for a minimum of 3 successive frames. In the case of multi-frame operation of UL Physical Channels, the UE shall only consider active frames for the evaluation of the *Recovery* criterion. The MAC in the UE shall consider that the TFC is in Supported state for the purpose of TFC selection.

MAC in the UE shall indicate the available bitrate for each logical channel to upper layers within T_{notify} from the moment the *Recovery* criterion was detected.

The UE shall consider the *Blocking* criterion for a given TFC to be fulfilled at the latest at the start of the longest uplink TTI after the moment at which the TFC will have been in Excess-Power state for a duration of:

$$(T_{\text{notify}} + T_{\text{modify}} + T_{\text{L1_proc}})$$

where:

T_{notify} equals 15 ms

T_{modify} equals $\text{MAX}(T_{\text{adapt_max}}, T_{\text{TTI}})$

$T_{\text{L1_proc}}$ equals 35 ms

$T_{\text{adapt_max}}$ equals $\text{MAX}(T_{\text{adapt_1}}, T_{\text{adapt_2}}, \dots, T_{\text{adapt_N}})$

N equals the number of logical channels that need to change rate

$T_{\text{adapt_n}}$ equals the time it takes for higher layers to provide data to MAC in a new supported bitrate for logical channel n. Table 5.4.3 defines T_{adapt} times for different services. For services where no codec is used T_{adapt} shall be considered to be equal to 0 ms.

Table: 5.4.3 - T_{adapt}

Service	T_{adapt} [ms]
UMTS AMR	40
UMTS AMR2	60

T_{TTI} equals the longest uplink TTI of the selected TFC (ms).

5.4.1.2 TFC selection in UE for 1.28 Mcps TDD option

The UE shall consider the *Elimination* criterion for a given TFC to be fulfilled if the estimated UE transmit power needed for this TFC is greater than the Maximum UE transmitter power for at least X out of Y successive measurement periods. The MAC in the UE shall consider that the TFC is in Excess-Power state for the purpose of TFC selection.

MAC in the UE shall indicate the available bitrate for each logical channel to upper layers within [15 ms] from the moment the *Elimination* criterion was fulfilled.

The UE shall consider the *Recovery* criterion for a given TFC to be fulfilled if the estimated UE transmit power needed for this TFC has not been greater than the Maximum UE transmitter power for at least Y successive measurement periods. The MAC in the UE shall consider that the TFC is in Supported state for the purpose of TFC selection.

MAC in the UE shall indicate the available bitrate for each logical channel to upper layers within T_{notify} from the moment the *Recovery* criterion was fulfilled.

The UE shall consider the *Blocking* criterion for a given TFC to be fulfilled at the latest at the start of the longest uplink TTI after the moment at which the TFC will have been in Excess-Power state for a duration of $(T_{\text{notify}} + T_{\text{modify}} + T_{\text{L1_proc}})$.

where:

T_{notify} equals [15] ms, and

T_{modify} equals $\text{MAX}(T_{\text{adapt_max}}, T_{\text{TTI}})$, and

$T_{\text{L1_proc}}$ equals 15 ms, and

$T_{\text{adapt_max}}$ equals $\text{MAX}(T_{\text{adapt_1}}, T_{\text{adapt_2}}, \dots, T_{\text{adapt_N}})$, and

N equals the number of logical channels that need to change rate, and

$T_{\text{adapt_n}}$ equals the time it takes for higher layers to provide data to MAC in a new supported bitrate, for logical channel n. Table 5.4.4 defines T_{adapt} times for different services. For services where no codec is used T_{adapt} shall be considered to be equal to 0 ms.

Table: 5.4.4 - T_{adapt}

Service	T_{adapt} [ms]
AMR	40

T_{TTI} equals the longest uplink TTI of the selected TFC (ms).

5.4.2 TFC selection method as a reference case for Enhanced Uplink

The important parameters to be included to the simulation assumptions for TFC selection method in the reference case are:

- Accuracy of the UE transmit power estimate. See table 5.4.2 in the previous section as a reference. This will have an effect on how fast the UE moves a certain TFC to excess power state. Since the accuracy depends on the currently used transmit power level, it is noted for the purpose of general understanding, that the accuracy is thus in average worse with a bursty traffic model, in which quite often only DTX is used with Special Bursts, than with more real-time type of application in which transmission of DPCH is more continuous. Also the location in the cell

will effect to the accuracy due to the same reason. It is however seen that for the sake of simplicity, it would be appropriate to define only one value for this parameter used in all simulations.

It is thus proposed that the accuracy defined for the maximum Ptx power level, ± 2 dB, is used in all cases, for the sake of simplicity of the simulations. This is to be modelled so that the error is lognormally distributed with zero mean and $\text{std}=1.2159$ dB, which has the effect of causing 90% of the errors to occur within ± 2 dB of the zero mean. It is noted that the accuracy requirements in [2] are also defined for 90% probability.

- b) Delay between the moment when the *elimination* criterion is met in L1 and when the TFC is moved into blocked state. See the previous section as a reference, together with the Annex A.6A.2.1.2.1 from [2], defining the maximum delay to be $T_{\text{detect_block}} + T_{\text{notify}} + T_{\text{modify}} + T_{\text{L1_proc}} + T_{\text{align_TTI}} + T_{\text{offset}}$. It is proposed that in the simulation assumptions the assumption is that there is no codec (e.g. AMR) involved, the rate of which should be adjusted and that the longest TTI in the selected TFC is $T_{\text{TTI}} = 10 \text{ ms} = T_{\text{modify}}$.
- c) Delay between the moment when the *recovery* criterion is met and when the TFC is moved back to supported state. See the previous section as a reference, together with the Annex A.6A.2.1.2.1 from [2], defining the maximum delay to be $T_{\text{detect_recovery}} + T_{\text{notify}} + T_{\text{modify}} + T_{\text{L1_proc}} + T_{\text{align_TTI}} + T_{\text{offset}}$. It is proposed that in the simulation assumptions the assumption is that there is no codec (e.g. AMR) involved, the rate of which should be adjusted and that the longest TTI in the selected TFC is $T_{\text{TTI}} = 10 \text{ ms} = T_{\text{modify}}$.
- d) TFCS; i.e. the set of allowed user bit rates allocated to the UE. These are the bit rates that UE can use in the TFC selection algorithm. There should be enough steps in the TFCS to allow the UE to decrease the used data rate in a flexible fashion at the cell edge.

5.5 Uplink Power Control

In this section, existing uplink power control procedures are reviewed. Procedures for both dedicated and shared uplink physical are different for 3.84 Mcps TDD and 1.28 Mcps TDD.

5.5.1 3.84 Mcps TDD

For 3.84 Mcps TDD an open-loop scheme is employed for uplink DPCH and PUSCH. The UE power is derived based upon the following inputs (see [5]):

- Pathloss as measured on beacon transmissions (this is calculated at the UE using the PCCPCH reference power signalled to the UE via BCH and beacon RSCP measurements)
- Uplink interference level on a per timeslot basis (this is derived by the Node-B and is signalled via the BCH, the update rate is dependent upon the SIB configuration but is generally relatively slow)
- An SIR target level as signalled by the RNC (dedicated RRC signalling). The SIR target may be derived by means of uplink error events (knowledge of these may be obtained via the CRC indicators passed to RNC via Iub or from RLC-information). The updates are made via the “uplink physical channel control” message or via the PSCHAM shared channel allocation message.
- The spreading factor of the physical channel. The power adjustment as a function of spreading factor is termed “gamma” (see [10]).
- The TFC selected by UE MAC. The power adjustment as a function of TFC is termed “beta” (see [10]).

Figure 5.5.1.1 shows the uplink system architecture for 3.84 Mcps:

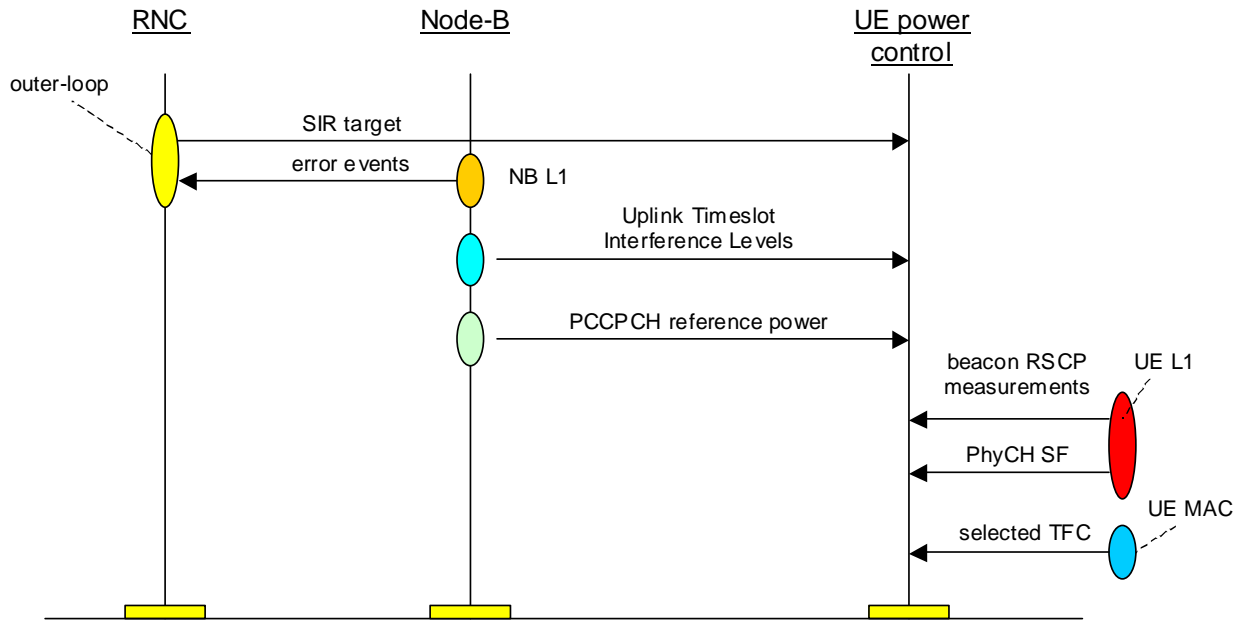

Figure 5.5.1.1 – Uplink power Control Architecture for 3.84Mcps TDD

5.5.2 1.28 Mcps TDD

Traditional closed-loop TPC power control is employed for uplink DPCH and PUSCH in 1.28Mcps TDD. The UE transmit power is based upon accumulated TPC commands sent by the Node-B on downlink dedicated or shared channels. The SIR target for the Node-B inner loop is set by higher layers. Note that an open-loop method may be used to set the initial transmission power before transiting into closed loop power control.

Figure 5.5.2.1 shows the uplink system architecture for 1.28 Mcps:

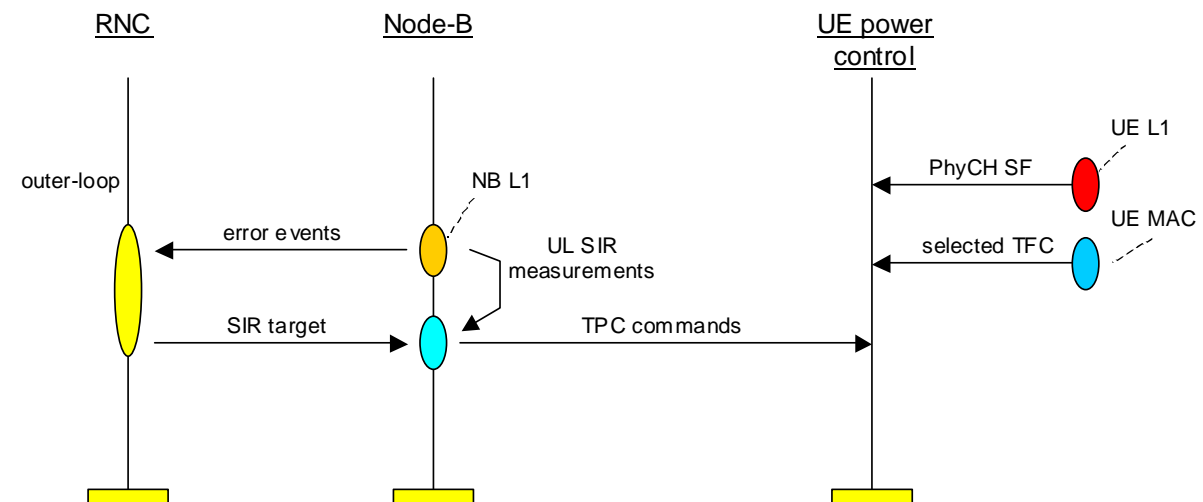

Figure 5.5.2.1 - Uplink power Control Architecture for 1.28Mcps TDD

6 Overview of considered Uplink Enhancements for UTRA TDD

6.1 Scheduling <Node B controlled scheduling, AMC>

It is proposed within [9] that the scheduling function at Node-B controls only the set of TFCs that may be selected by active UEs and (possibly additionally) their times of transmission. These techniques try to control the power received from each UE such that the combined received power level is within acceptable noise rise over thermal (RoT) limits. TFC control is possible within existing R99/4/5 standards albeit on a slower basis due to the fact that the controlling function is located within the RNC. Migration and enhancement of this mechanism to the Node-B (within the scheduler) along with the time-scheduling component is desirable to provide finer and more accurate control of the resulting RoT at the Node-B receiver. Better management of the RoT helps to reduce its variance when compared to RNC-centric TFCS control which may improve uplink capacity and throughput.

Transferring some form of TFC control and time-scheduling functionality to the Node-B is also expected to provide similar benefits for TDD systems in terms of a better interference management. It is envisaged however that additionally for TDD the Node-B scheduler will need to incorporate an ability to dynamically share available code resources amongst active UEs. This is a direct consequence of the differences in uplink multiple access architecture between FDD and TDD.

For FDD, except at very low spreading factors, the code resources occupied by each UE do not affect those available to other UEs since each is assigned a unique scrambling sequence. There is thus no need in FDD to directly control the code resources used by each UE, only the rate (and/or time) of transmission. In contrast, for TDD all UEs within a cell share the same scrambling sequence and are instead separable by means of their OVFSF sequences. OVFSF code resources on the TDD uplink must therefore be carefully managed in order to avoid the possibility of a code-limited system. This has implications for the TDD Node-B scheduler in that unlike FDD, it must be able to dynamically re-assign the available uplink OVFSF code resources amongst users according to their traffic needs and/or channel conditions. In this respect, the TDD Node-B scheduling function for uplink mirrors the functionality present in the (TDD and FDD) MAC-hs for downlink; fast (re)-allocation of code resources is required when there is finite availability of those code resources.

Furnishing the scheduler with the ability to quickly re-assign code resources is necessary to enable the physical resources available to the UE to be varied in accordance with the UEs uplink traffic volume profile and the prevailing channel conditions. Firstly this allows for efficient accommodation of the bursty traffic typical of background and interactive services and is likely to increase perceived end-user throughput via a reduction in buffer-queue latency. Secondly it allows for allocations to be tailored to the UEs current data rate capability thereby minimising wastage or over-allocation of code resources.

In summary it is proposed that the TDD uplink would benefit from the following functionality being located within the Node-B:

- Fast control over the transmission data rates available for selection by the UE (rate scheduling):
 - this allows for scheduling algorithms that are able to provide better and finer control over interference
- Fast control over the timeslots and OVFSF codes used for transmission (physical resource scheduling):
 - this mitigates against finite code resource limitations and enables efficient assignment of physical resources in the presence of varying (bursty) traffic profiles and changeable radio conditions

A further important consequence of UEs sharing the same (cell-specific) scrambling sequence is that for TDD it is likely to be beneficial for enhanced uplink data transmissions to be scheduled (ie: contentionless transmission should be maintained for transmission of uplink data on the enhanced uplink channel).

6.1.1 Node-B Rate Scheduling

In Rel5, the uplink scheduling and rate control function resides in the RNC. By providing the Node-B with similar tools, tighter control of the uplink interference is possible which in turn, may result in increased capacity and improved coverage.

In [9] the term “Node-B rate scheduling” denotes a function whereby the Node-B has control over the set of TFCs (denoted “Node B controlled TFC subset”) from which the UE may choose a suitable TFC employing the Rel5 TFC selection algorithm (or modifications thereof if applicable). Any TFC in the Node B controlled TFC subset might be

selected by the UE, provided there is (1) sufficient power margin, (2) sufficient data available, (3) the TFC is not in the blocked state. The Node B controlled TFC subset relates to the TFCS and minimum set defined in Rel5 in the following ways:

- "TFCS". This is identical to the TFCS in Rel5 and is the set of all possible TFCs as configured by the RNC.
- "Node B controlled TFC subset". The TFC selection algorithm in the UE selects a TFC from the "Node B controlled TFC subset". Note that the "Node B controlled TFC subset" is equal to or a subset of the TFCS and, at the same time, equal to or a superset of the minimum set, i.e.. "Minimum set" \subseteq "Node B controlled TFC subset" \subseteq "TFCS".
- "Minimum set". This is identical to the minimum set in Rel5 as specified in [5]. The UE can always select a TFC from the minimum set as TFCs in the minimum set can never be in the blocked state.

In Figure 6.1.1.1, the different (sub)sets are illustrated.

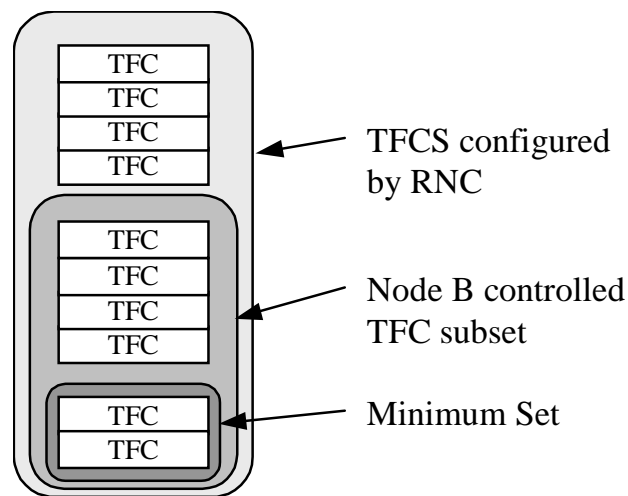

Figure 6.1.1.1: Illustration of different sets of TFCs.

The ideas behind the "Node-B controlled TFC subset" are similar to the use of *transport format combination control* specified in [5]. This signalling is typically used to allow the RNC to control the allowed uplink transport formats by specifying a "TFC subset" along with an optional duration under which the "TFC subset" is valid. Node-B rate scheduling can be viewed as providing the Node-B with similar tools, but allowing for faster adaptation to interference variations. The interaction between RNC TFC control and Node-B TFC control is FFS, although a preferable solution is to require the UE not to choose a TFC outside any of these restrictions.

Using this technique, the Node-B is therefore able to effectively place an upper bound on the uplink transmission rate (and hence received power). The actual transmission rate may be further reduced from this allowed maximum by the UE in the event that a) there is not sufficient data in the UE buffer or b) that the channel conditions do not permit the transmission of the Node-B-assigned maximum rate (TFC in blocked state). As such for FDD, the scheduler controls the maximum-rate TFC that is permitted and this in-turn has a direct impact on the physical resources (SF) occupied by the transmission.

It is envisaged that the techniques of Node-B rate control will also bring benefits to TDD. However, matters are slightly different in that it is desirable for the scheduler to allocate code resources in order to avoid code resource blocking (see section 6.1 and 6.1.2). As such, the transmission rate would already (to some degree) be under the control of the scheduler, but by means of the allocated code resources not by means of the maximum allowed TFC. Unfortunately, knowledge of the allocated code resources alone does not result in a predictable received power level at the Node-B due to the fact that the coderate of the selected TFC has much influence on this too. As such it is clear that in order to achieve accurate rate scheduling, one must jointly consider both the physical resources allocated and the transmission rates that map to those physical resources.

The set of available TFCs at the UE would therefore be determined via the following factors:

- the physical resources allocated to the UE by the Node-B
- the transmit power requirements of each TFC in relation to the maximum allowed UE transmission power

- further restrictions and control imposed by the Node-B rate scheduler

6.1.2 Node-B Physical Resource Scheduling

Dynamic assignment and re-assignment of physical resources (timeslots and OVSF codes) is an important facet of an efficient TDD uplink system in which there are finite code resources, especially when supporting bursty background and interactive services (cf: HS-DSCH for downlink in release 5). The envisaged benefits of dynamic physical resource scheduling at the Node-B are listed below:

1. Avoidance of code resource blocking

Dynamic code resource allocation allows for accommodation of a larger number of session-active users in the presence of variable traffic source rate from each user. Fixed resource allocation is unable to adapt to such variations and can be inefficient for interactive and background services.

2. Better tracking of UE buffer status

The ability to vary the amount of allocated resources quickly in response to UE buffer indications can significantly reduce latency and improve packet call throughput.

3. Better tracking of radio conditions

The ability to vary the amount of allocated resources quickly in response to radio conditions allows the scheduler to maximise the packing efficiency of the available physical resource space and to reduce occurrences of over-allocation, thereby improving overall cell throughput.

4.Reduced latency

By moving the resource allocation function to the Node-B, latencies are likely to improve. The latency involved in the initial request/grant of physical resources may be reduced due to an avoidance of some Iub delays in this process. UTRAN stack delays are also potentially avoided. Removal of the Iub and UTRAN stack delays may similarly improve the latencies associated with scheduling for retransmission over those observed in release 5.

5.Co-location of the scheduler with the (H)-ARQ function

System performance is likely to benefit from a close coupling of the physical resource scheduling, rate scheduling and (H)-ARQ functions. Having them located within the same network entity is therefore desirable.

6.1.3 Higher-Order Modulation

3.84Mcps release 5 TDD supports QPSK modulation only. 8-PSK is additionally allowed for 1.28Mcps TDD.

Higher order modulations may carry benefits for the TDD uplink due to the finite OVSF code resources available in the cell (all users share a cell specific scrambling code).

When considering higher-order modulations as an enhancement, the following aspects should be taken into account:

- link performance
- system performance
- impacts to the UE power amplifier

6.2 Hybrid ARQ

6.2.1 General

Node B controlled hybrid ARQ allows for rapid retransmissions of erroneously received data units, thus reducing the number of RLC retransmissions and the associated delays. This can improve the quality of service experienced by the end user. As a Node B controlled retransmission is less costly from a delay perspective, the physical channel can be operated with somewhat higher error probability than in Rel 5, which may result in improved system capacity. The retransmission probability for the initial transmission is preferably in the order of 10-20% when evaluating hybrid ARQ. Significantly higher retransmission probabilities may lead to considerably reduced end user throughput, while at very small retransmission probabilities the Node B controlled hybrid ARQ will not provide any additional gains compared to R99/4/5. Soft combining can further improve the performance of a Node B controlled hybrid ARQ mechanism.

Not all services may allow for retransmissions, e.g., conversational services with strict delay requirements. Hybrid ARQ is thus mainly applicable to interactive and background services and, to some extent, to streaming services.

Thus, the major targets from a performance point of view with hybrid ARQ to consider in the evaluation of uplink hybrid ARQ are

- reduced delay
- increased user and system throughput

The design of an uplink hybrid ARQ scheme should take the following aspects into account:

- Memory requirements, both in the UE and the Node B. Rapid retransmissions reduce the amount of buffer memory required in the Node B for buffering of soft bits when a retransmission has been requested.
- Low overhead. The overhead in terms of power and number of bits required for the operation of the hybrid ARQ protocol should be low, both in uplink and downlink.
- In-sequence delivery. The RLC requires in sequence delivery of MAC-d PDUs. Note that the in sequence delivery mechanism can be located either in the Node B or the RNC, depending on the scheme considered.
- Multiplexing of multiple transport channels. Hybrid ARQ cannot be used by all transport channels and multiplexing of transport channels using hybrid ARQ and those not using hybrid ARQ needs to be considered. In the downlink, there is a separate CCTrCh carrying the HS-DSCH. Consideration is required on whether the assumption of a separate CCTrCh is desirable in the uplink scenario. In R99/4/5, up to two uplink CCTrCHs are allowed.
- UE power limitations. The operation of the UE controlled TFC selection for R99/4/5 channels need to be taken into account in the design. In particular, UE power limitations in conjunction with activity on other transport channels with higher priority should be considered.
- Complexity. The hybrid ARQ schemes studied should minimize as much as possible the additional implementation complexity at all involved entities.

6.2.2 Transport Channel Processing

A protocol structure with multiple stop-and-wait hybrid ARQ processes can be used, similar to the scheme employed for the downlink HS-DSCH, but with appropriate modifications motivated by the differences between uplink and downlink. The use of hybrid ARQ affects multiple layers: the coding and soft combining/decoding is handled by the physical layer, while the retransmission protocol is handled by a new MAC entity located in the Node B and a corresponding entity located in the UE.

ACK/NAK signalling and retransmissions are done per uplink TTI basis. Whether multiple transport channels using hybrid ARQ are supported and whether there may be multiple transport blocks per TTI or not are to be studied further. The decision involves e.g. further discussion whether the current definition of handling logical channel priorities by the UE in the TFC selection algorithm remains as in R99/4/5 or if it is altered. It also involves a discussion on whether different priorities are allowed in the same TTI or not. The R99/4/5 specifications require a UE to maximize the transmission of highest priority logical channel in each TTI. If this rule is maintained, the delay for different logical channel priorities could be different, depending on whether the TFCS contains one or several transport channels.

Where possible it is intended to re-use functional blocks of the transport channel processing schemes available in R99/4/5. Transport blocks are coded and rate matching is used to match the number of coded bits to the number of channel bits. If multiple transport channels are multiplexed, rate matching will also be used to balance the quality requirements between the different transport channels. Note that multiplexing of several transport channels implies that the number of bits may vary between retransmissions depending on the activity, i.e., the retransmission may not necessarily consist of the same set of coded bits as the original transmission.

Incremental redundancy with multiple redundancy versions is mainly beneficial at a relatively high initial code rate. Explicit support for multiple redundancy versions, if desired, could be incorporated in the rate matching process as was done for HS-DSCH.

6.2.3 Associated Signalling

Associated control signalling required for the operation of a particular scheme consists of downlink and uplink signalling. Different proposals may have different requirements on the necessary signalling. Furthermore, the signalling structure may depend on other uplink enhancements considered.

The overhead required should be kept small in order not to waste power and code resources in the downlink and not to create unnecessary interference in the uplink.

Downlink signalling consists of a single ACK/NAK per (uplink) TTI from the Node B. Similar to the HS-DSCH a well-defined processing time from the reception of a transport block at the Node B to the transmission of the ACK/NAK in the downlink can be used in order to avoid explicit signalling of the hybrid ARQ process number along with the ACK/NAK. The details on how to transmit the ACK/NAK are to be studied further.

The necessary information needed by the Node B to operate the hybrid ARQ mechanism can be grouped into two different categories: information required prior to soft combining/decoding (outband signalling), and information required after successful decoding (inband signalling). Depending on the scheme considered, parts of the information might either be explicitly signaled or implicitly deduced, e.g., from CFN or SFN.

The information required prior to soft combining consists of:

- Hybrid ARQ process number.
- New data indicator. The new data indicator is used to control when the soft combining buffer should be cleared in the same way as for the HS-DSCH.
- Redundancy version. If multiple redundancy versions are supported, the redundancy version needs to be known to the Node B. The potential gains with explicit support of multiple redundancy versions should be carefully weighted against the increase in overhead due to the required signalling.
- Rate matching parameters (number of physical channel bits, transport block size). This information is required for successful decoding. In R99/4/5, there is a one-to-one mapping between the number of physical channel bits and the transport block size, given by the TFCI and attributes set by higher layer signalling. This assumption does not hold for hybrid ARQ schemes if the number of available channel bits varies between (re)transmissions, e.g., due to multiplexing with other transport channels. Hence, individual knowledge of these two quantities is required in the Node B.

The information required after successful decoding can be sent as a MAC header. The content is similar to the MAC-hs header, e.g., information for reordering, de-multiplexing of MAC-d PDUs, etc.

The information needed by UE necessary to operate the hybrid ARQ mechanism is either explicitly signaled by Node B, or decided by the UE itself, depending on the scheme. It is noted that whether the UE will decide the parameter values or the Node B will signal them, could affect the round trip time for HARQ retransmissions.

6.3 Fast Allocation of Dedicated or Shared Resources

6.4 Signalling

Editor's Note: This section shall describe the new signalling that is required to support the evaluated enhancement techniques and / or enhancements to existing signalling.

6.5 Physical Layer Enhancements

6.5.1 Open-Loop-Assisted TPC Power Control

The following relates to a power control scheme which may be suitable for use with E-UCH within an enhanced uplink system.

The scheme uses open-loop assistance to a traditional TPC scheme.

The scheme is detailed in figure 6.5.1.1. In this example the outer-loop for E-UCh is located within the Node-B although implementation with the outer-loop in the RNC is also possible. When located within the Node-B, the outer-loop may be tightly coupled to the MAC-e scheduling and HARQ functions. When located within the RNC, the SIR target would be signalled to the Node-B by the RNC.

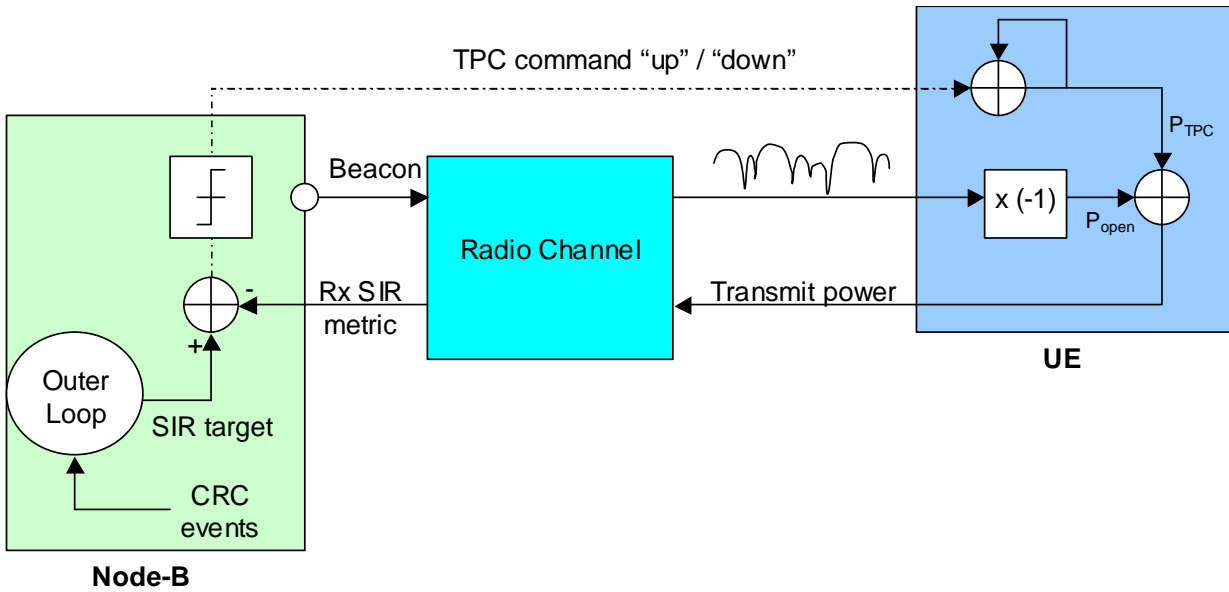

Figure 6.5.1.1: Open-loop-assisted TPC power control scheme

In figure 6.5.1.2, P_{TPC} is the power contribution of the TPC component, and P_{open} is the contribution of the open-loop (pathloss) component.

Thus for frame k :

$$P_{TPC}(k) = step \times \sum_{i=k-K}^K TPC_i \text{ dB}$$

- where K is the number of frames since the power control process was started, TPC_i is -1 for a “down” command and +1 for an “up” command and “step” is the magnitude of the amount added to an accumulator upon receipt of each TPC command and:

$$P_{open}(k) = P_{PCCPCH} - RSCP_{beacon}(k) \text{ dB}$$

- where P_{PCCPCH} is the beacon reference transmit power for the cell and $RSCP_{beacon}$ is the received beacon signal level at the UE.

Accounting for the “gamma” (γ_{SF}) and “beta” (β_{TFC}) adjustments as a function of spreading factor and transport format as in the release 5, the overall transmission power is then defined as:

$$P_{Tx}(k) = P_{open}(k) + P_{TPC}(k) + \gamma_{SF} + \beta_{TFC} + Q_0 \text{ dB}$$

- where Q_0 is a constant representing the initial value of the TPC accumulator. This would typically be derived by the UE as a function of the interference level signalled on the BCH at the time of the start of the call or at the time of transmission following a significant pause in TPC feedback. It would also be a function of an appropriate received SIR level for the format.

The scheme has the following properties:

- The loop is able to adapt quickly to pathloss changes observed at the UE. The responsiveness of the loop is likely to improve at slow to medium channel speeds when compared to traditional TPC loop at the same update rate.
- The loop is able to adapt quickly to interference level changes via the TPC feedback. This is likely to be quicker than the BCH SIB-based interference level feedback in the current release 5 open-loop scheme as used for 3.84Mcps TDD.

- The loop comprises mechanisms that may assist with power control during uplink transmission pauses and during pauses in the TPC feedback. The open loop component may still be updated and track pathloss changes even though the TPC feedback has paused.
- Both TDD modes may share a common power control architecture in the enhanced uplink context.
- The outer-loop responsible for setting the SIR target may reside either in the Node-B (where it may be tightly coupled to the MAC-e scheduling and H-ARQ functions) or in the RNC. If located in the Node-B, no signalling of enhanced uplink BLER or quality is required over Iub.
- RRC signalling of an SIR target is not required as the outer-loop is closed by the TPC feedback.

Architecturally, the open-loop-assisted TPC power control scheme is as shown in figure 6.5.1.3. In this example the outer-loop is shown in the Node-B although the SIR target could be signalled to the Node-B by the RNC.

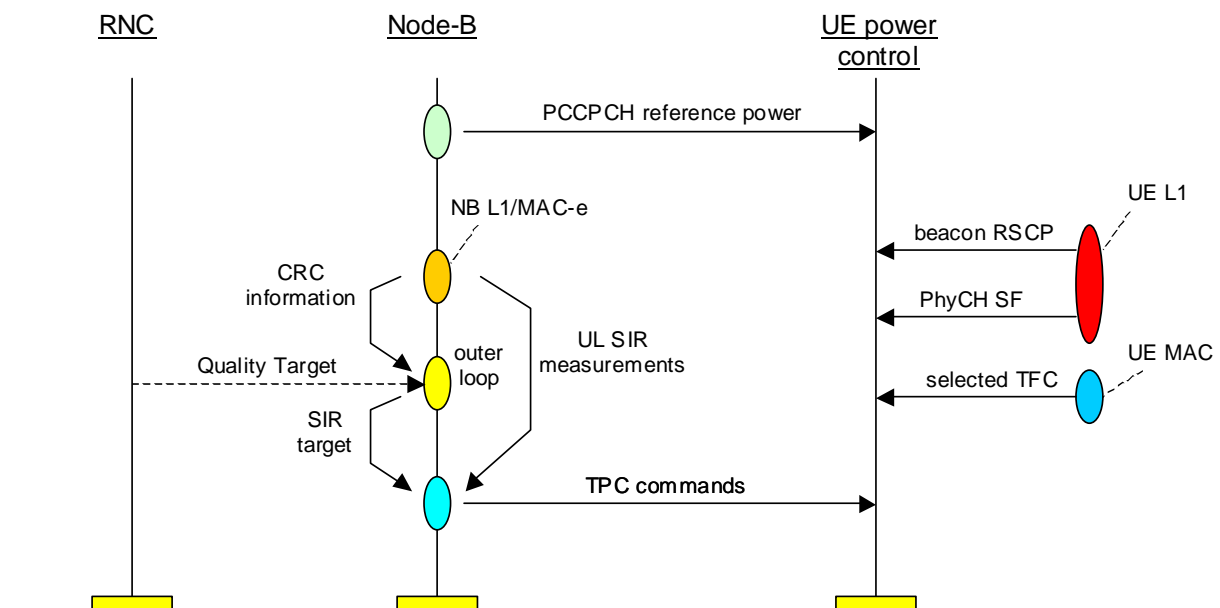

Figure 6.5.1.2 – Architecture of the open-loop-assisted power control scheme for enhanced uplink

6.5.2 Intra-frame Scrambling Code Hopping

Code hopping has been found to be an effective technique for improving performance and reducing performance variability of a short-code CDMA system. In the current UTRA TDD system, code hopping is implemented in the form of *Cell Parameter Cycling*. However EU-TDD will not be able to exploit this feature as the TTI of an EU-TDD transport channel will be 10ms or less. Hence intra-frame code hopping is required for EU-TDD.

The effective spreading code of a burst is determined by the scrambling code and the channelization code. A common scrambling code and a unique channelization code are used for bursts transmitted in a timeslot within a cell. Code hopping may be implemented either by cycling scrambling codes, cycling the channelization codes or by a combination of both.

An intra-frame code hopping scheme for EU-TDD where only the scrambling code is changed on a slot-by-slot basis for all uplink users in the cell is suggested. In the proposed scheme, the scrambling code is changed on a slot-by-slot basis within each frame as shown in Figure 6.5.2.1. The hopping period may be set to any number of timeslots up to 15. Making the hopping period greater than 15 timeslots (10 ms) will not provide any additional gain as the TTI is at most 10ms. The scrambling codes used for code hopping can either belong to the set of scrambling codes defined in TS 25.223 or a new set of scrambling codes may be defined. If existing scrambling codes were to be used, careful network planning is necessary to avoid an EU-TDD burst using the same scrambling code as a non EU-TDD burst in a neighbouring cell. The details of the proposed hopping scheme are for further study.

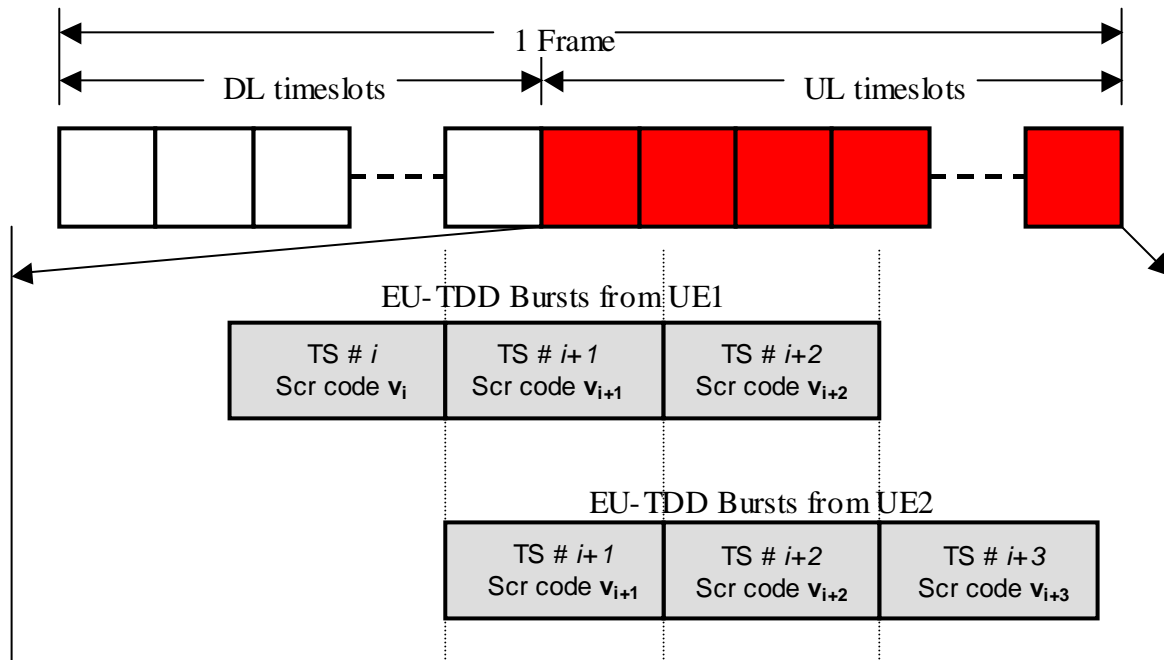

Figure 6.5.2.1 Proposed Scrambling Code Hopping Scheme

7 Physical Layer Structure Alternatives for Uplink Enhancements for UTRA TDD

Editor's Note: This section is expected to contain a more detailed description of the proposed modifications to physical layer structure(s) in time and code domain that are required to support considered uplink enhancements. This section will be used as a basis for defining the simulation assumptions in the annex.

7.1 Relationship to existing transport channels

It remains to be determined whether there will be a new transport channel added to RAN specification. Uplink enhancements may

- consist of methods limited on improving the utilisation of existing dedicated or shared uplink transport channels or
- introduce methods that require new transport and physical channels

In order to encompass both possibilities, the transport channel is referred to here as the “Enhanced Uplink CHannel” E-UCH.

7.1.1 Transport Channel Structure

To support some of the enhancements currently under consideration, a new transport channel type, the E-UCH, is introduced. Depending on future decisions on which enhancements to support and how to support them, the E-UCH may or may not have similarities to the USCH or DCH.

In order to find a suitable structure for supporting the E-UCH, the following issues have been considered:

- The number of E-UCHs supporting simultaneous transmission
- Static or semi-static TTI.

- One or multiple CCTrCHs. Either one or multiple uplink CCTrCHs are required, depending on the physical channel structure adopted.

In the interests of simplicity and alignment with recent decisions in the FDD E-DCH work item, it is envisaged that there will be

- one E-UCH per UE (see also 7.1.1.1)
- a single static TTI of 10 ms for 3.84 Mcps DD (a single static 5 ms TTI may be considered for 1.28 Mcps TDD) (see also 7.1.1.2)
- one CCTrCH of E-UCH type per UE

In Figure 7.1.1.1, a generic structure is illustrated, which assumes one E-UCH per UE and one CCTrCH.s of E-UCH type per UE. A new MAC-es/MAC-e entity is introduced to handle multiplexing of MAC-d flows, hybrid ARQ (this retransmission protocol is similar to that provided by the HS-DSCH hybrid ARQ protocol)...

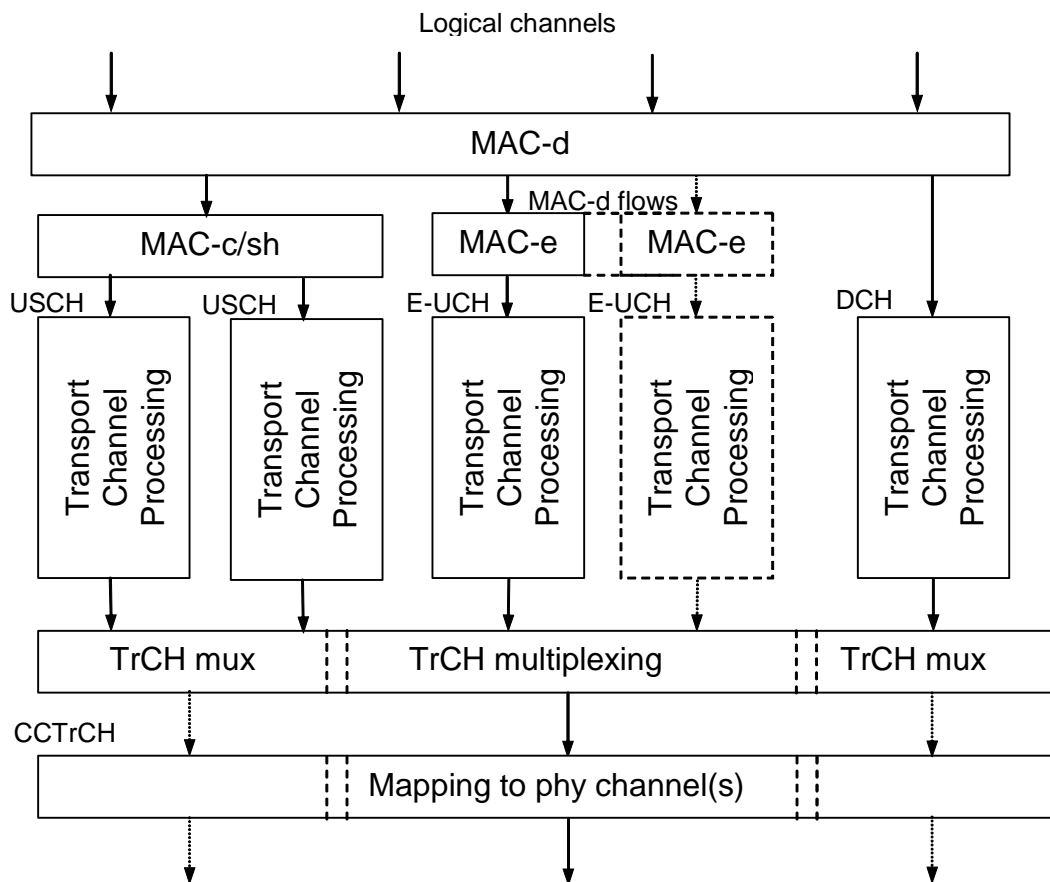

Figure 7.1.1.1: Simplified illustration of possible transport channel structures(UE side).

7.1.1.1 Number of E-UCHs

Supporting only one E-UCH may simplify transport channel multiplexing and reduce the amount of additional outband signalling. MAC layer multiplexing may be used to support (simultaneous) transmission of multiple MAC-d flows (possibly with different priorities) into a single transport channel. In-band signalling may be used for separating the received data into different MAC-d flows instead of relying on the TFCI.

Supporting multiple E-UCHs may allow for greater flexibility but may require more outband signaling compared to a single E-UCH. One E-UCH can be set up for each MAC-d flow. Out-band TFCI signalling is used to demultiplex the received data into multiple transport channels/MAC-d flows.

The interaction with TFC selection needs to be considered. According to Rel5, logical channels in the uplink have absolute priority, i.e., the UE shall maximise transmission of high priority data in each TTI. Whether this rule is to be maintained for the E-UCH or not is FFS, although the TFC selection needs to take both legacy transport channels (USCHs, DCHs) and E-UCHs into account. For TDD, considering the transmit power aspects, TFC selection for legacy

channels could be performed without interaction with MAC-es/MAC-e if legacy channels (USCH or DCH) and E-UCH are not allowed to co-exist in the same timeslot. Extending the Rel5 principle, E-UCH TFC selection and MAC-e (if applicable) multiplexing must be jointly designed in order not to “starve” low-priority MAC-d flows.

It is assumed that there will only be one E-UCH per UE, for simplicity and to achieve maximum commonality with FDD E-DCH [11]. Imposing the restriction that that legacy uplink physical channels and uplink E-UCH physical channels may not be supported in the same timeslot may minimise the impact of E-UCH on existing specifications.

7.1.1.2 TTI

A static TTI, i.e., the specifications mandate a single TTI value to be supported by the E-UCH, may simplify the processing. Obviously a static TTI will prohibit the use of (hybrid) ARQ in conjunction with TTIs other than the one specified for E-UCH.

If a static TTI were used, a value of 10ms (for 3.84Mcps TDD) is envisaged in order to align the E-UCH TTI with the TDD HS-DSCH TTI, with the FDD E-DCH 10ms TTI option and with the TDD 10ms framing structure. For 1.28Mcps, a 5ms may be considered in order to align with the existing sub-frame duration. A semi-static TTI, i.e., the network configures the TTI to use when configuring the E-UCH, is in line with other Rel5 transport channels and may be useful in some situations. However, the additional complexity associated with this more flexible functionality may not warrant its inclusion.

8 Evaluation of Techniques for Enhanced Uplink

8.1 Scheduling <Node B controlled scheduling, AMC>

8.1.1 Performance Evaluation

A key benefit of Node-B scheduling when compared to scheduling in earlier releases is that of traffic latency. By moving the scheduler into the Node-B, the latency of traffic is reduced due to:

- Faster scheduling response to UE buffer volume measurements
- Faster scheduling response for retransmissions
- Removal of multiple traversals of the Iub interface for retransmissions

These effects have been simulated for a system scenario using the modified gaming traffic model of [9] for two sets of scheduling parameters (Table 8.1.1.1):

Table: 8.1.1.1

Parameter	Release-5 based	Enhanced uplink based	Comments
Scheduling	RNC based	Node-B scheduling of enhanced uplink code resource space	
Scheduling delay	100ms	20ms	
ACK/NACK delay	100ms	10ms	Time from PDU arriving at Node-B and the ACK/NACK being received by the UE
BLER target	1%	10%	Assumed that faster retransmission delay enables operation at more efficient BLER

for E-UL

The gaming traffic model was defined by the following parameters (see also [9] for a general description):

Table: 8.1.1.2 - Parameter Settings for the Modified Gaming model

Parameter	Value	Comment
Mean packet call duration	5s	Exponential distribution
Mean reading time	5s	Exponential distribution
Datagram size	576 bytes	Fixed
Mean datagram interarrival time	40 ms	Log-normal distribution, 40 ms standard deviation
Resulting mean data rate during packet call	115.2 kbps	

Other parameters used in the simulations are listed in table 8.1.1.3:

Table: 8.1.1.3

Parameter	Value	Comments
Carrier Frequency	2000MHz	
Chip Rate	3.84Mcps	
Frequency Re-use	N=1	
Layout	12 sites with rectangular wrap-around	
Sectorisation	Tri-sectored	
Pathloss model	$128.15 + 37.6 \log_{10}(d)$ dB	From 3GPP TS 25.942
Cell radius	1000m	Inter-site distance 2000m
Shadow fading standard deviation	8dB	Log normal
Node-B antenna gain	14dBi	
Node-B receiver noise figure	5dB	
Node-B Rx diversity	2 antennas	
UE antenna gain	0dBi	
Users per cell	8,12,14,16,18,20	
Number of uplink timeslots	8	
Traffic model	Modified Gaming	
Scheduling	Round-robin	Max TTI resource per user = 1xSF4, 8 timeslots
Channel type	Pedestrian-B 3kmph	All users
Power control	On	

The simulation was run for 8, 10, 12, 14, 16, 18 and 20 gaming users per cell, presenting mean offered loads of 460 to 1152kbps per sector. For each user the datagram delay times were recorded and averaged over the period of each simulation. The CDFs of the datagram delays are plotted in figure 8.1.1.1 below:

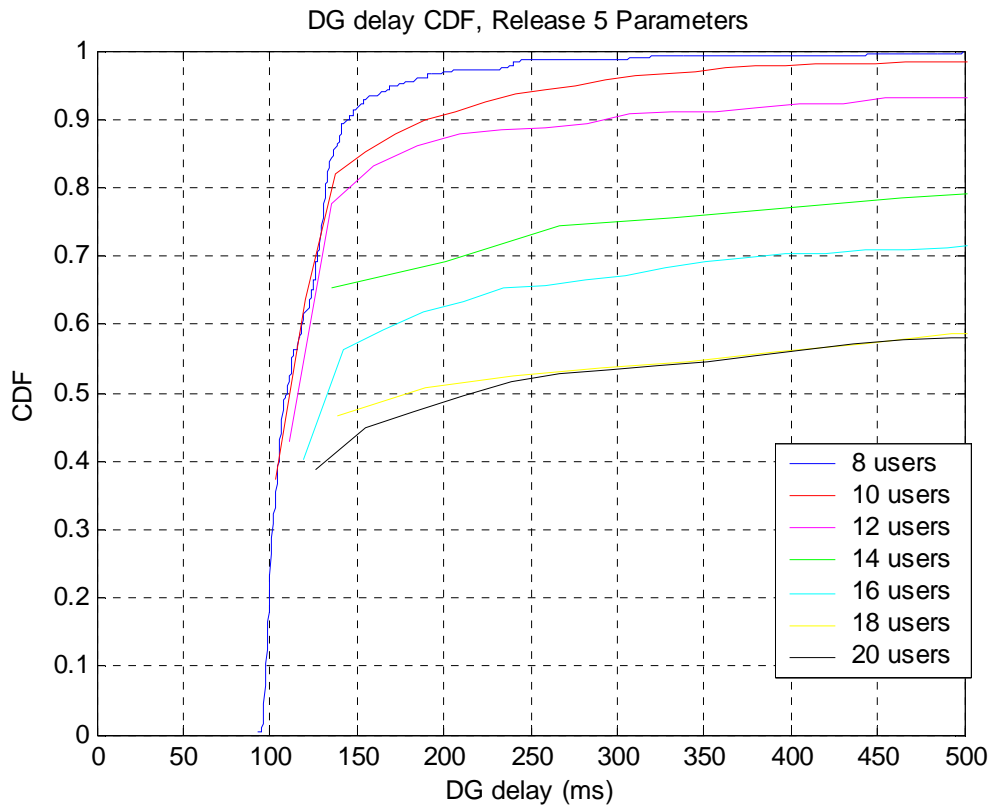

Figure 8.1.1.1 – Datagram delay CDF, Rel-5 scheduling parameters, modified gaming model, round robin scheduler

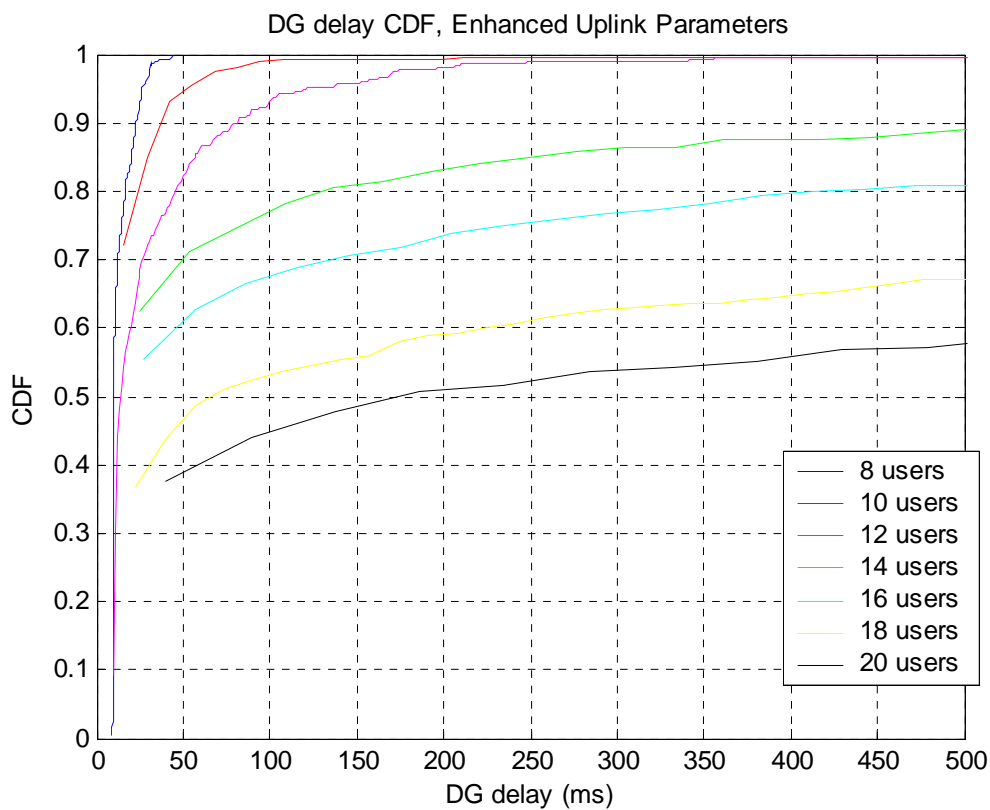

Figure 8.1.1.2: Datagram delay CDF, E-UL scheduling parameters, modified gaming model, round robin scheduler

As for many other traffic types, gaming traffic is sensitive to delay. The exact sensitivity is subjective however, and dependent upon the exact application. A reasonable assumption is to stipulate that 99% of datagrams should experience a delay of less than eg: 250ms in order to not impair the gaming experience.

Comparing figures 8.1.1.1 and 8.1.1.2, this corresponds to 8 and 12 users for the release 5 and enhanced uplink parameter sets respectively, or a 50% increase in the number of satisfied users in the cell for the same quality of service.

In terms of packet call throughput, the gains are less significant due to the long mean length of a packet call in the gaming model (5 seconds) ie: the latency improvements are small in comparison to the packet call duration. Packet call throughput is however seen to increase by a factor of approximately 10% to 15% depending on the loading (figure 8.1.1.3).

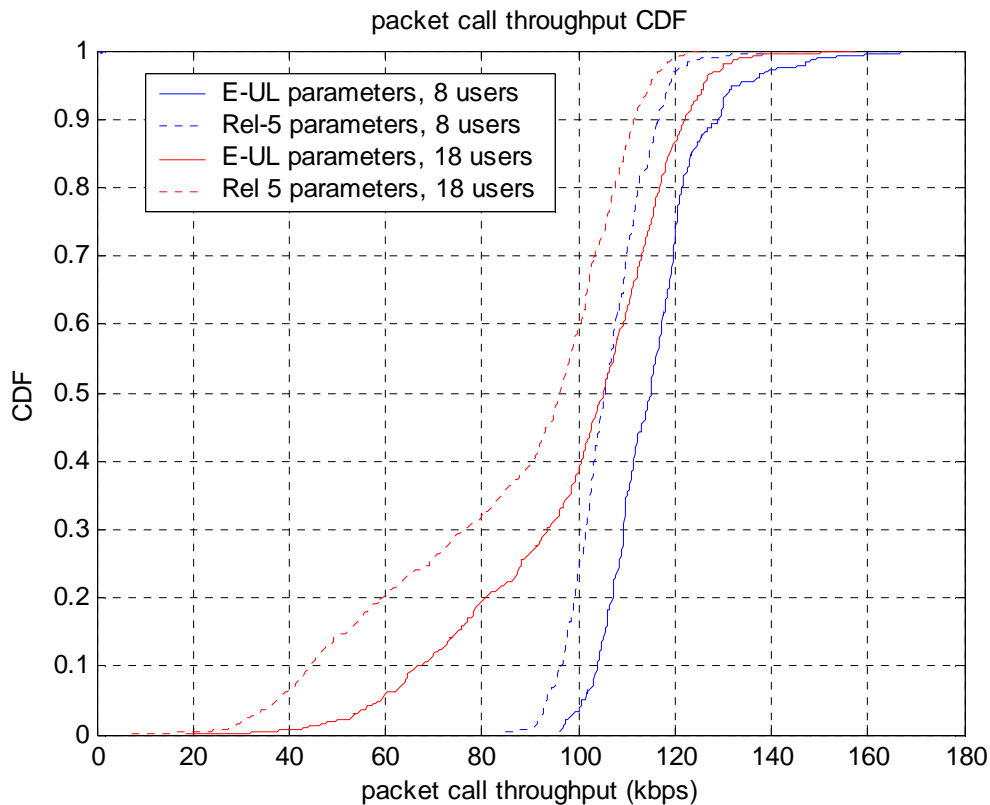

Figure 8.1.1.3: Packet call throughput CDFs at low and high loading, modified gaming model

Packet call throughput improvements arising due to scheduling and ACK/NACK delay improvements become much more noticeable as the mean packet call duration is reduced. The results of figure 8.1.1.4 show an example of this for the same modified gaming traffic model in which the mean packet call duration has been reduced from 5 seconds to 500ms. As can be seen, the packet call throughput gain increases to approximately 50%.

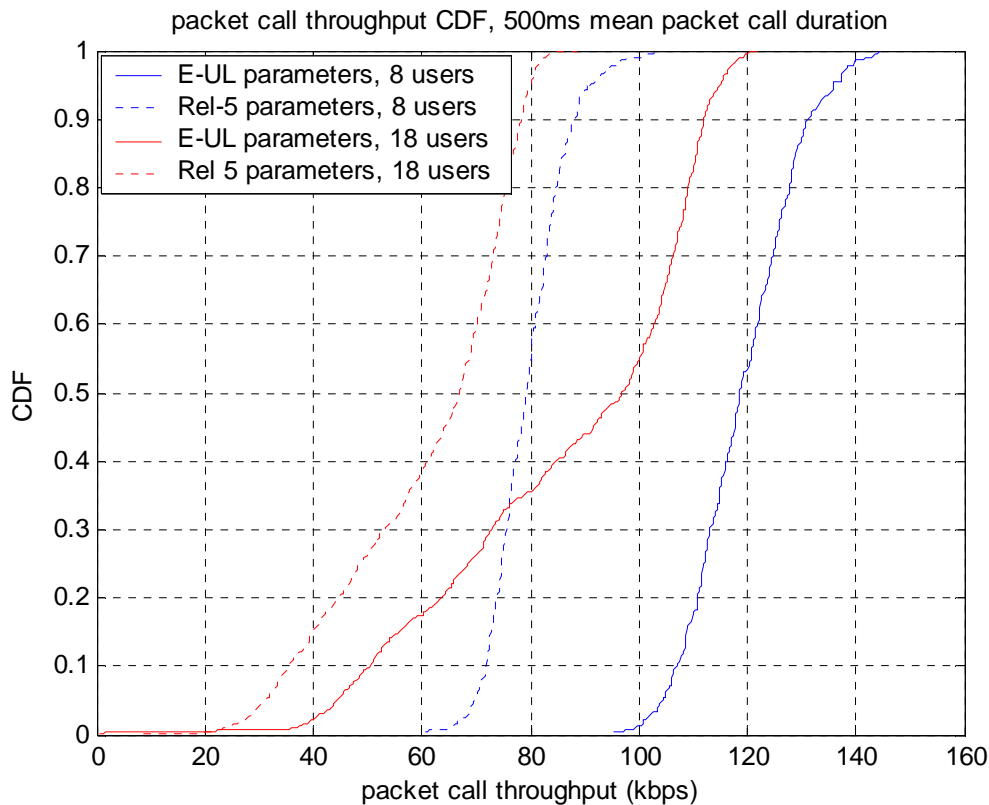

Figure 8.1.1.4: Packet call throughput CDFs at low and high loading, modified gaming model with 500ms mean packet call duration

As such, the packet call throughput experienced by users for bursty services with short packet call times are likely to be significantly enhanced by means of Node-B scheduling.

In addition to traffic delay and packet call throughput benefits associated with Node-B scheduling, other aspects of Node-B scheduling in an enhanced uplink system are:

- i) the scheduler may be located in the same entity as the H-ARQ function, allowing for accurate resource scheduling as a function of buffer status and retransmission requirements
- ii) the scheduler may be co-located with the MAC-hs scheduler for HS-DSCH, such that uplink and downlink resource requirements may be jointly considered
- iii) buffer volume reports and measurement from the UE of relevance to the scheduler may experience lower delay and improve the responsiveness of the scheduler to channel conditions and buffer status

It should be noted that the results presented within this section analyse performance of the scheduling aspects only. When used in conjunction with other proposed enhancements (notably H-ARQ and 8-PSK), buffer delay will be further reduced due to increases in sector throughput (see sections 8.2 and [8.1.6]).

8.1.2 Complexity Evaluation <UE and UTRAN impacts>

From a UE perspective, the complexity associated with Node-B scheduling is relatively small. The UE must be able to demodulate and decode the scheduling and ACK/NACK messages (see section 8.1.3). These scheduling messages effectively substitute those higher-layer scheduling messages for release 5. The ACK/NACK messages are additional to release 5. The delay aspects of decoding the signaling must be jointly considered with UE complexity when selecting suitable downlink signaling in order to achieve minimum scheduling delay at reasonable complexity. However, this is not anticipated to prove problematic (cf: HS-SCCH for HS-DSCH).

Some additional RRC signaling may be required to support Node-B scheduling.

From a UTRAN perspective, Node-B scheduling would require additional Iub signaling to support configuration of the enhanced uplink resources. Additionally, the instantiation of the scheduler within MAC-e is non-trivial. However, the scheduling function is likely to be of similar complexity to that for HS-DSCH in release 5 and as such is considered feasible.

8.1.3 Downlink Signalling

In order to support Node-B scheduling, new downlink signaling would need to be introduced to carry the scheduling information from the Node-B to the UE.

It is anticipated that the scheduling information would be carried by means of physical layer signaling between MAC-e peer entities. The times of transmission of the scheduling information and ACK/NACK information are not necessarily coincident and as such separate physical channels for ACK/NACK and for scheduling information would be advantageous.

The exact nature of the downlink signaling is not of concern to this study although it is assumed that scheduling information to be carried to the UE may include:

- code resources
- timeslot resources
- rate scheduling information
- UE identity
- The length of grant (shortest 1 TTI, longest duration TBD)

8.1.4 Uplink Signalling

New uplink signaling would be required in order to convey information from the UE to the Node-B in order to assist with scheduling decisions (for example buffer volume, current channel conditions, etc ...). The details of this signaling may remain FFS.

8.1.5 Compatibility with earlier Releases

It is assumed that the Node-B scheduler would be allocated a pool of power and physical (code/timeslot) resources over which it has arbitration amongst contending enhanced uplink users. These resources would be distinct and separate from those under control of the RNC for legacy uplink channels. In this sense, the enhanced uplink system may co-exist with earlier releases under the control of the RNC.

8.1.6 8-PSK

Of the set of higher-order modulations, 8-PSK is particularly of interest due to its constant-envelope nature.

8-PSK was studied for FDD during the E-DCH study item phase [9] but was not included in the work item due to the fact that 3 x BPSK naturally outperformed 1 x 8-PSK.

However, for FDD, because each UE is assigned a scrambling code, the code resources in the cell on the uplink are plentiful and the system is usually interference-limited. Thus the 3 x BPSK is an attractive option. For TDD however, a scrambling code is assigned to each cell, and OVSF code resources are thus more limited. As such, it is necessary to look at both link and system impacts of 8-PSK in the context of an enhanced uplink TDD system.

This section presents results on 8-PSK link performance (section 8.1.6.1) and corresponding system performance (section 8.1.6.2). PAR aspects are considered in section 8.1.6.3.

8.1.6.1 Link Performance

Simulations have been performed for 8-PSK in AWGN and ITU Indoor-to-outdoor Pedestrian-B channel (3kmph). Power control is enabled and receive diversity is disabled.

There are two aspects to the link performance:

1. the loss associated with the 8-PSK modulation scheme
2. the coding gain associated with 8-PSK for the same information data rate as a QPSK transmission occupying the same code resource (the physical channel capacity is increased and so a lower coderate may be used)

In order to evaluate the modulation loss aspect, a single SF8 code using 8-PSK was compared to 3 x SF16 codes using QPSK, these two having the same physical channel capacity. Thus, for a given transport block size the coderate on each is the same. However, the code resources used by the QPSK transmission are 50% greater than for the 8-PSK transmission. This increase in required code resources may be viewed as one “cost” of using QPSK modulation.

Four transport block sizes were considered, resulting in four different coderates. 1/3 rate turbo coding and burst type 1 are assumed throughout. For simplicity, single-slot formats were simulated.

Table 8.1.6.1.1 lists the simulated formats:

Table: 8.1.6.1.1

ID	OVSF resource	Modulation	TrBlk Size	Coderate
1	3 x SF16	QPSK	244	0.3333
2	1 x SF8	8-PSK	244	0.3333
3	3 x SF16	QPSK	366	0.5
4	1 x SF8	8-PSK	366	0.5
5	3 x SF16	QPSK	488	0.6667
6	1 x SF8	8-PSK	488	0.6667
7	3 x SF16	QPSK	608	0.8306
8	1 x SF8	8-PSK	608	0.8306

Performance results are shown in figures 8.1.6.1.1 through 8.1.6.1.4.

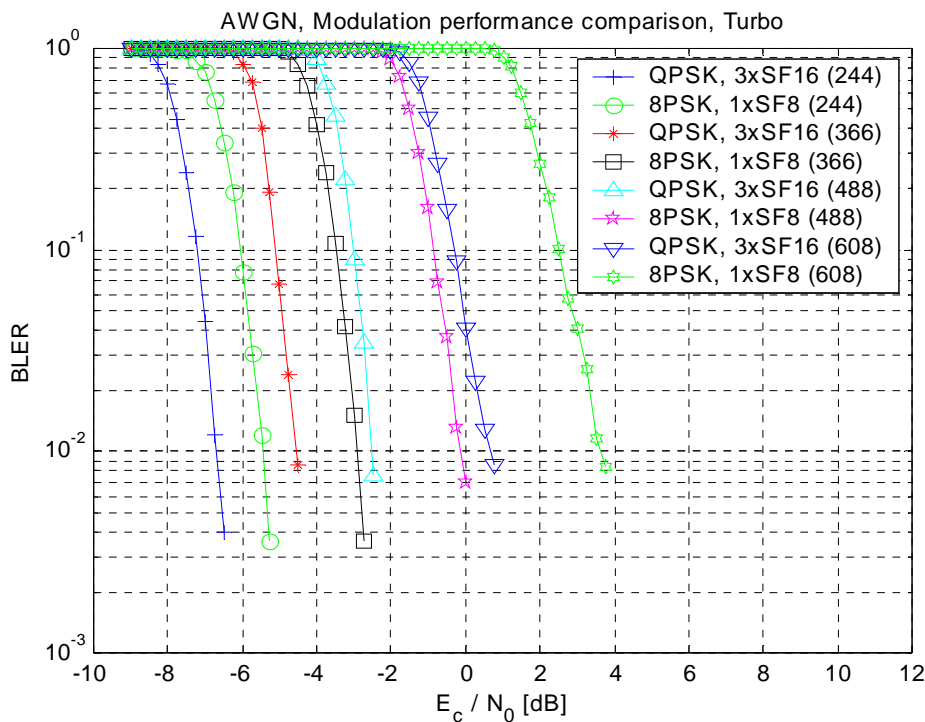

Figure 8.1.6.1.1: QPSK and 8-PSK BLER performance, AWGN

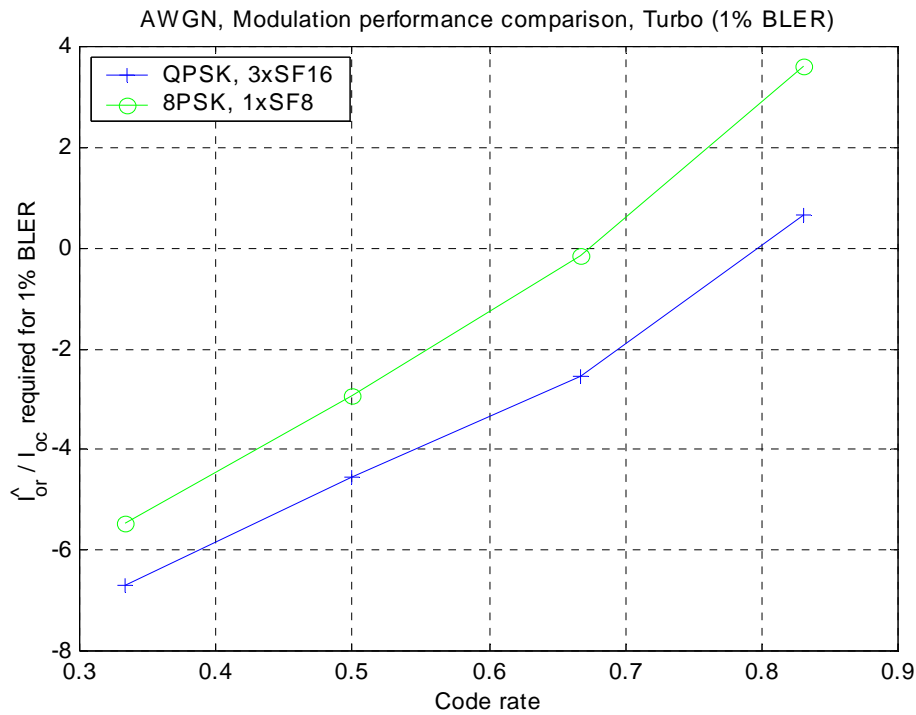

Figure 8.1.6.1.2: QPSK/8-PSK performance comparison, AWGN

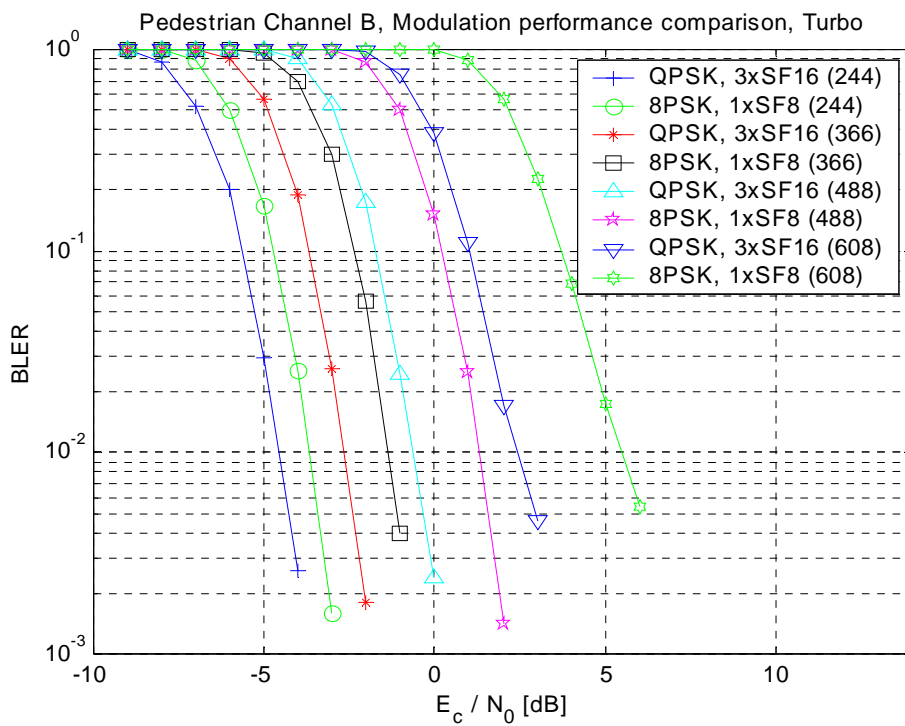

Figure 8.1.6.1.3: QPSK and 8-PSK BLER performance, Pedestrian-B

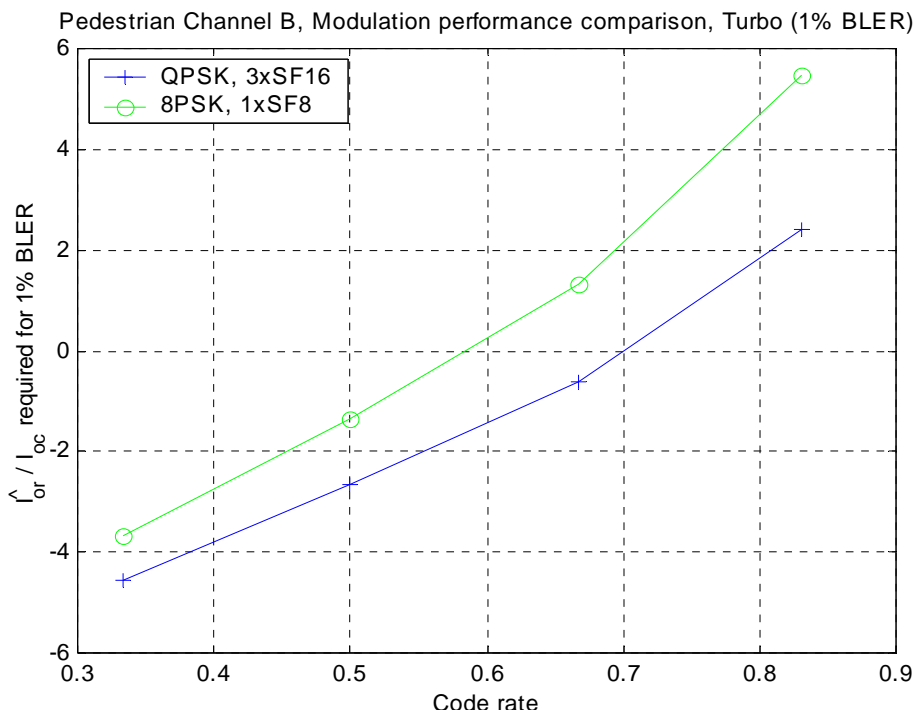

Figure 8.1.6.1.4: QPSK/8-PSK performance comparison, Pedestrian-B

As expected, 3 x QPSK SF16 consistently out-performs 1 x SF8 8-PSK. For a given data rate, the power of the link is minimized if QPSK modulation is used. This is because in the 3xSF16 case, more of the orthogonal code dimension is exploited to increase the data rate, whereas in the 8-PSK case, the additional data rate comes at the expense of a decreased minimum distance between constellation points for the same symbol power.

In terms of the second aspect of 8-PSK link performance (coding gain), QPSK and 8-PSK modulation were compared using the same amount of code resources and at the same data rate. Thus, a lower coderate is afforded for the 8-PSK case and is able to counteract, to a greater or lesser degree, the loss associated with the modulation.

Formats considered for this evaluation are listed in table 8.1.6.1.2 and results are presented in figures 8.1.6.1.5 and 8.1.6.1.6 for AWGN and Pedestrian-B respectively.

Table: 8.1.6.1.2

ID	OVSF resource	Modulation	TrBlk Size	Coderate
1	1 x SF4	QPSK	488	0.5
2	1 x SF4	8-PSK	488	0.3333
3	1 x SF4	QPSK	682	0.7
4	1 x SF4	8-PSK	682	0.47
5	1 x SF4	QPSK	732	0.75
6	1 x SF4	8-PSK	732	0.5
7	1 x SF4	QPSK	760	0.78
8	1 x SF4	8-PSK	760	0.52
9	1 x SF4	QPSK	814	0.83
10	1 x SF4	8-PSK	814	0.56

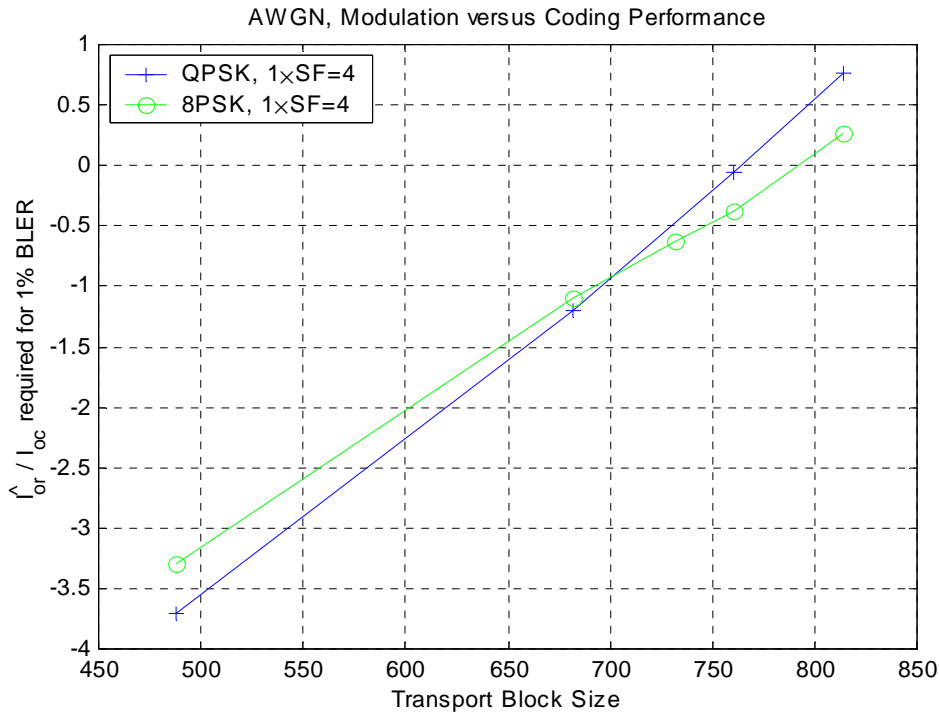

Figure 8.1.6.1.5: 8-PSK vs: QPSK at the same data rate and using equal code resources, AWGN

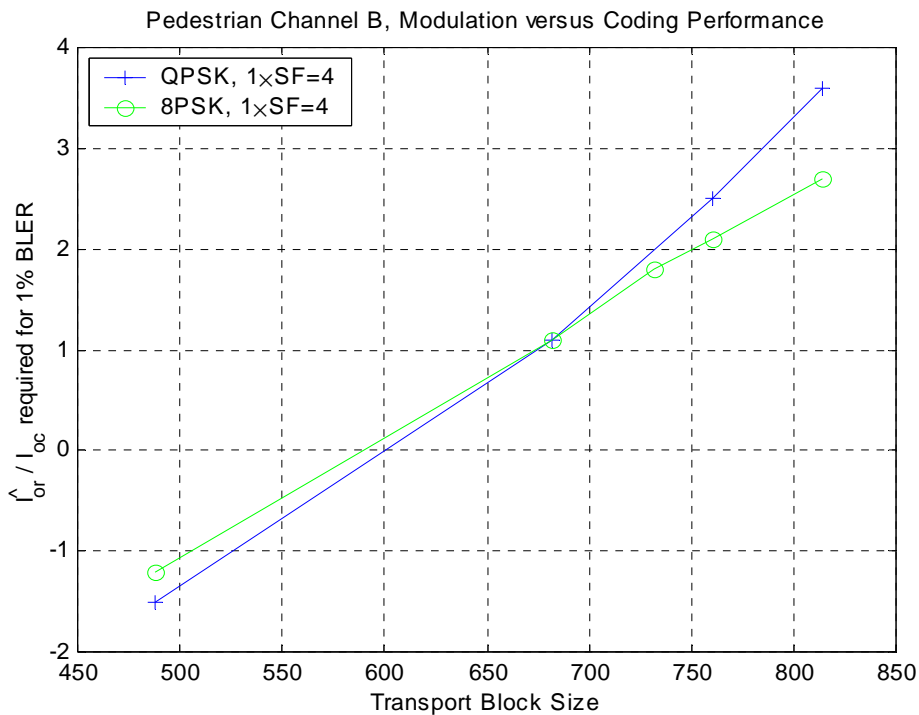

Figure 8.1.6.1.6: 8-PSK vs: QPSK at the same data rate and using equal code resources, Pedestrian-B

It is evident that there becomes a point at which the coding gain from using 8-PSK outweighs the modulation loss. For AWGN the net gain of 8-PSK for high data rate formats is of the order of 0.5dB. For pedestrian-B the net gain is of the order of 1dB.

8.1.6.2 System Performance

Although from a link perspective it is advantageous to utilise QPSK and maximise the used code resources for a user whenever possible in order to minimise the mean transmission power, this is not always practical:

- i. available uplink code resources are taken away from other users and,
- ii. the peak to average power ratio (PAR) is increased due to the multi-code transmission.

The results of section 8.1.6.1 indicate that a net gain may be realised by using 8-PSK when code resources are limited.

To investigate the impact of (i), system simulations have been performed in order to determine whether or not there is a net system gain to be had from the inclusion of 8-PSK in an enhanced uplink system.

System parameters were as follows:

Table: 8.1.6.2.1 – System simulation parameters

Parameter	Value	Comments
Carrier Frequency	2000MHz	
Chip Rate	3.84Mcps	
Frequency Re-use	N=1	
Layout	12 sites with rectangular wrap-around	
Sectorisation	Tri-sectored	
Pathloss model	$128.15 + 37.6 \log_{10}(d)$ dB	From 3GPP TS 25.942
Cell radius	1000m	Inter-site distance 2000m
Shadow fading standard deviation	8dB	Log normal
Node-B antenna gain	14dBi	
Node-B receiver noise figure	5dB	
Node-B Rx diversity	2 antennas	
UE antenna gain	0dBi	
Users per cell	20	
Number of uplink timeslots	8	
Traffic model	Full buffer	
Scheduling	Round-robin	Max resource per user = 1xSF4, 8 timeslots
Channel type	Pedestrian-B 3kmph	All users
Power control	On	10% BLER target

The scenario of table 8.1.6.2.1 was simulated for two cases. In case 1, all TFCs available to the UEs used QPSK modulation only. For case 2, the set of available TFCs included both QPSK and 8-PSK modulation types. Sector throughput was analysed as a function of the rise over thermal in the cell (controlled by the scheduler). The rise over thermal is defined as the power at the Node-B receiver which may not be resolved by the joint detection receiver. The results obtained are shown in figure 8.1.6.2.1.

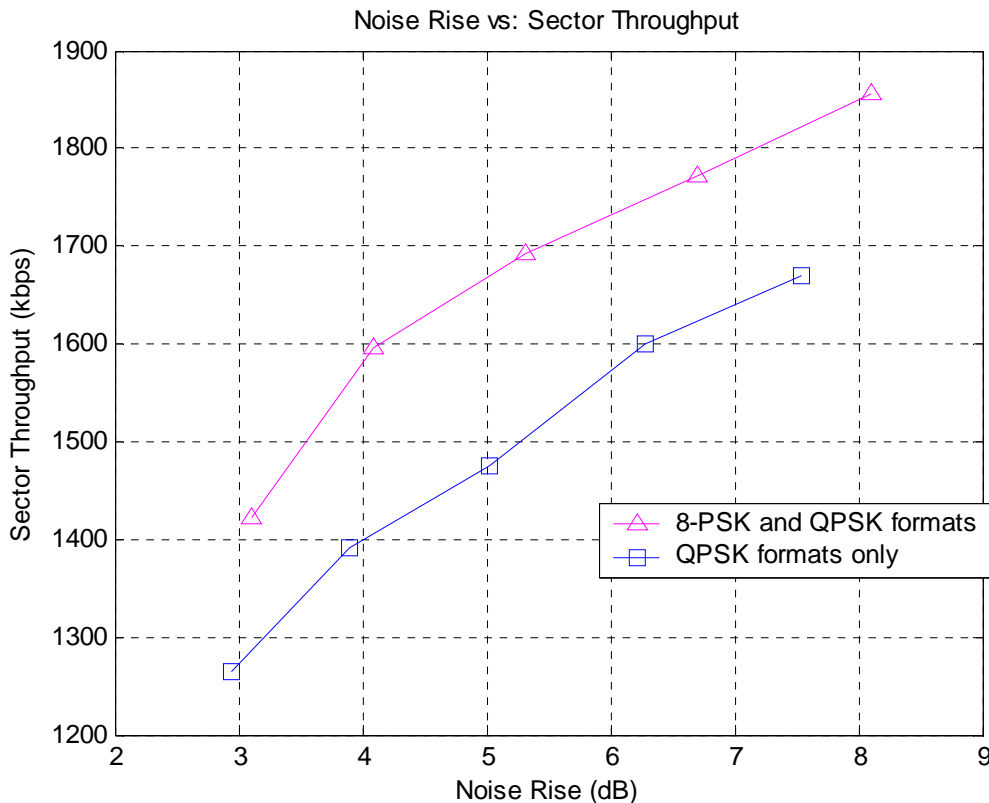

Figure 8.1.6.2.1: Sector throughput with and without 8-PSK (8 uplink timeslots)

From figure 8.1.6.2.1, it can be seen that the throughput gain of the system is improved by between 10% and 15% when 8-PSK formats are enabled.

8.1.6.3 Peak to average power ratio

In order to verify that the inclusion of 8-PSK would not cause adverse effects on the UE power amplifier, simulations have been conducted in order to quantify the impact of 8-PSK modulation in terms of PAR.

A histogram of the instantaneous signal power was recorded across multiple monte-carlo simulation runs in which channelisation code and scrambling codes were selected at random. A ratio was then formed for each histogram 'bin' by dividing the bin by the by the mean power. Thus a histogram of the instantaneous signal power to mean power ratio was generated. This was then integrated to form the signal CDF.

SF16 was used as the basis of the simulations. Both QPSK and 8-PSK with 1, 2 and 3 codes were simulated. In addition, SF8 8-PSK was simulated to verify that the impact of the spreading factor on the signal CDF was not significant. The following cases were thus studied:

- a) 1 x SF16, QPSK
- b) 2 x SF16, QPSK
- c) 3 x SF16, QPSK
- d) 1 x SF16, 8-PSK
- e) 2 x SF16, 8-PSK
- f) 3 x SF16, 8-PSK
- g) 1 x SF8, 8-PSK

Note that case (b) may be used as the benchmark for existing Release-5 3.84Mcps TDD equipment capable of 2-code transmission using QPSK.

The CDF results are plotted in figure 8.1.6.3.1.

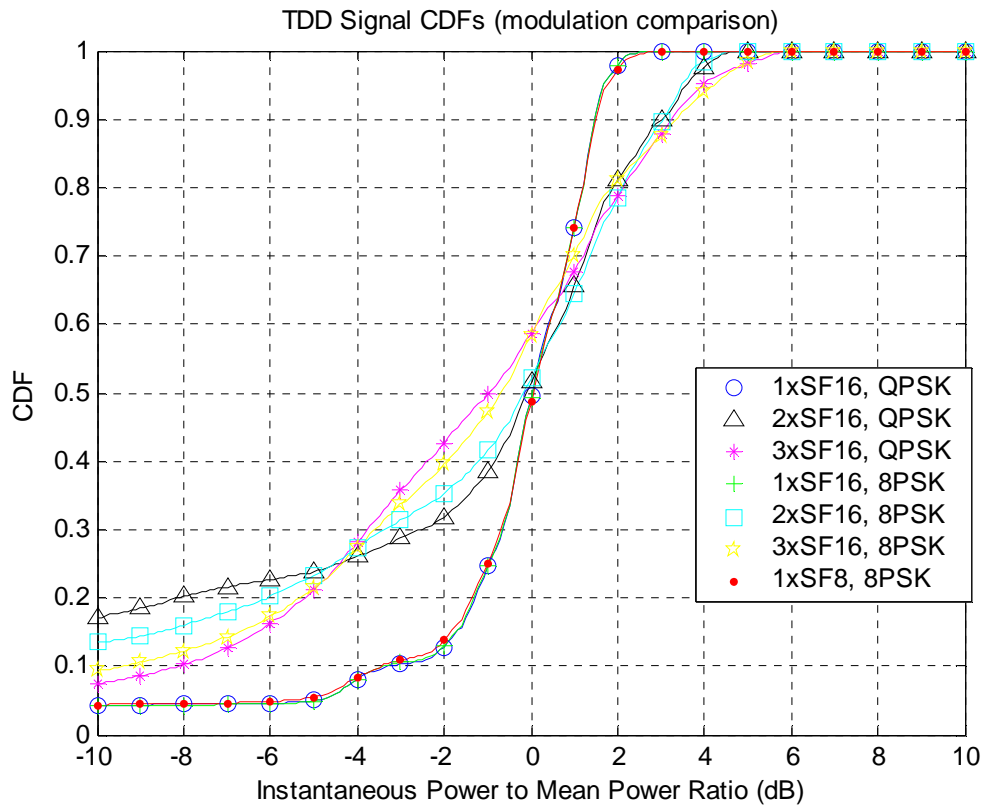

Figure 8.1.6.3.1: TDD Signal Amplitude Properties

The region of interest is where the CDFs approach 1. That is to say, it is of interest to determine a ratio of the instantaneous power relative to the mean power which is exceeded only x% of the time, as this bears some relation to the degree of power amplifier backoff required in the UE. A reasonable comparison point is x=99.9%. Figure 8.1.6.3.2 shows a zoomed plot of the region of interest.

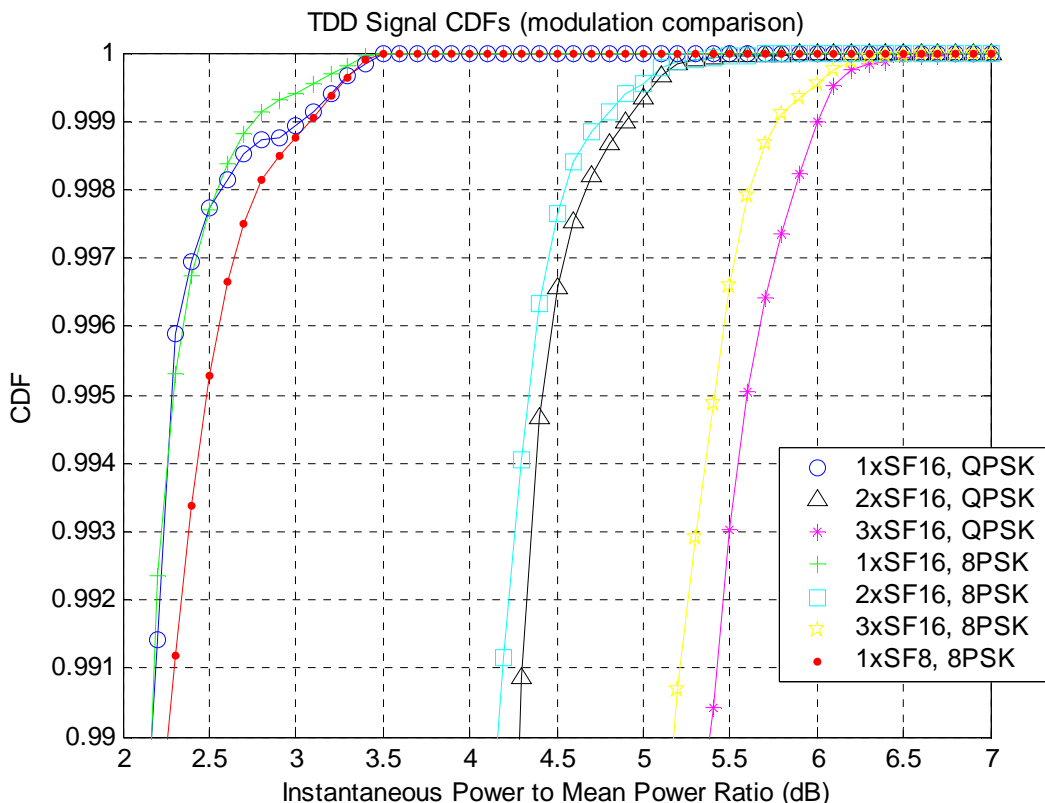

Figure 8.1.6.3.2: TDD Signal Amplitude Properties (zoomed)

For the 99%-‘ile point, the UE PA backoffs of table 8.1.6.3.1 are obtained:

Table: 8.1.6.3.1

OVSF resource	Modulation	UE PA backoff
1 x SF16	QPSK	3.0dB
2 x SF16	QPSK	4.8dB
3 x SF16	QPSK	6.0dB
1 x SF16	8-PSK	2.7dB
2 x SF16	8-PSK	4.7dB
3 x SF16	8-PSK	5.8dB
1 x SF8	8-PSK	3.1dB

The results indicate that 8-PSK is actually able to deliver a slightly lower PAR than QPSK for the same number of OVSF codes (a gain of approximately 0.1 to 0.3dB). The effect of SF on the PAR is small compared to the number of codes, and so these relative (QPSK vs: 8-PSK) results are assumed to also apply for lower SF.

If enhanced uplink transmissions were limited to a single OVSF code per timeslot, on which no other legacy channel transmissions existed then the mean UE PA output power could be increased without change to the UE PA design. The magnitude of this increase is of the order of 1.8dB and 2.1dB for QPSK and 8-PSK respectively, and is relative to the Release-5 2xSF16 QPSK case.

8.2 Hybrid ARQ

8.2.1 Performance Evaluation

8.2.1.1 Hybrid ARQ Link Performance

In this section, link level performance results of hybrid ARQ with and without chase combining are presented for the Rel-99 384kbps UL reference measurement channel with a 10ms TTI. The results are provided in an ITU Pedestrian A channel at a velocity of 3kmph.

Simulation assumptions are provided in Table 8.2.1.1.1 below.

Table: 8.2.1.1.1 - Simulation assumptions

Parameter	Value
Chip rate	3.84 Mcps
Carrier Frequency	2 GHz
Propagation Channel	ITU Pedestrian A, 3 kmph
Channel Estimation	Realistic
Inner loop open power control	ON (based off Beacon measurements)
Outer loop power control	OFF
Power control delay	4 timeslots
Beacon transmit diversity	Enabled
Antenna configuration	2 antenna receive diversity
Receiver	Joint Detector
Channel over-sampling	4 samples/chip
Turbo code information	Max log MAP, 4 iterations
Information bit rate	384 kbps
Resource occupied	1 x SF 2, 3 timeslots, burst type 2
Maximum number of transmissions	4
TTI	10ms
Hybrid ARQ	No combining (NC) / Chase combining (CC)
AC/NACK signaling error	NONE
Rate matching	Release 99

The throughput is calculated as the information bit rate divided by the average number of transmissions required. The throughput is shown in Figure 8.2.1.1.1 for a Pedestrian A 3kmph channel plotted against the mean received C/I per antenna branch for each of the transmissions. From the figure it can be seen that chase combining provides a throughput gain in situations where the received C/I is low and insufficient for hybrid ARQ without chase combining to operate.

Figure 8.2.1.1.2 shows the average number of transmissions required in a Pedestrian A 3kmph channel. It can be observed that for a given low C/I , chase combining can reduce the number of transmissions required significantly from that of no combining of transmissions at the receiver.

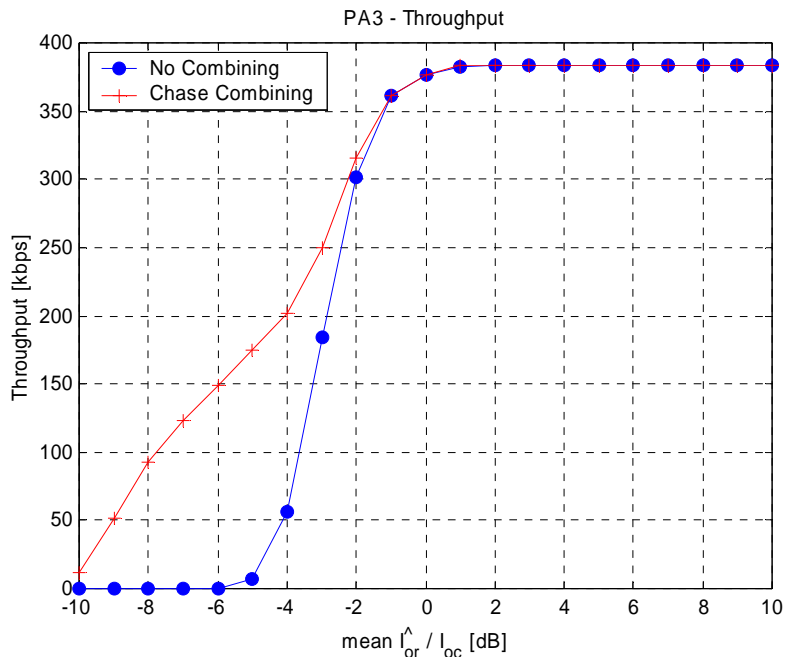

Figure 8.2.1.1.1: Throughput in a Pedestrian A 3kmph with power control.

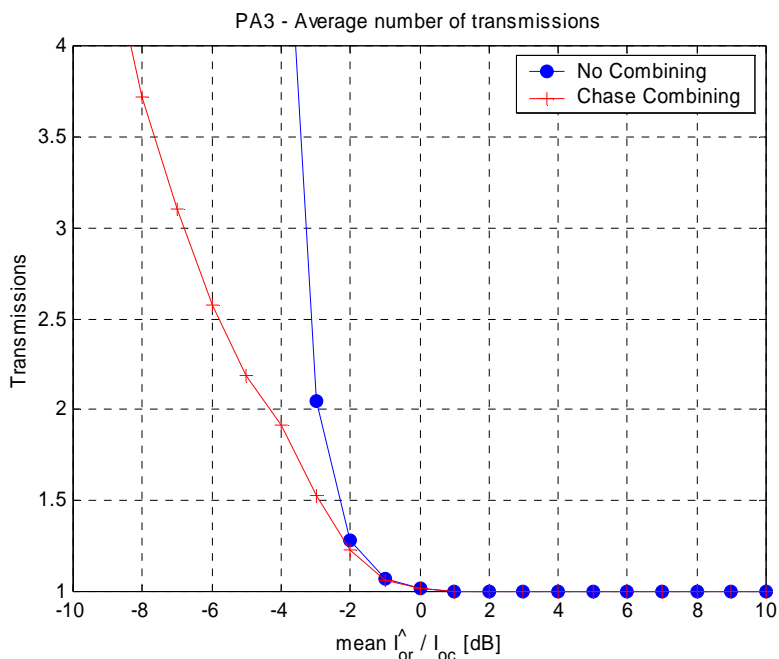

Figure 8.2.1.1.2: Average number of transmission in a Pedestrian A 3kmph with power control.

Figure 8.2.1.1.3 shows the BLER curves for the 384kbps bearer in a Pedestrian A 3kmph channel for each transmission with chase combining applied at the receiver. This figure demonstrates that even with nearly 100% BLER on the initial transmission, after 3 re-transmissions chase combining will enable a final BLER of below 1%.

Figure 8.2.1.1.4 shows the delay distributions with the initial transmission BLER being approximately 50% and 10%. From this it is observed that with an initial transmission BLER of approximately 50%, chase combining requires only two transmissions in order to achieve a final BLER below 1%.

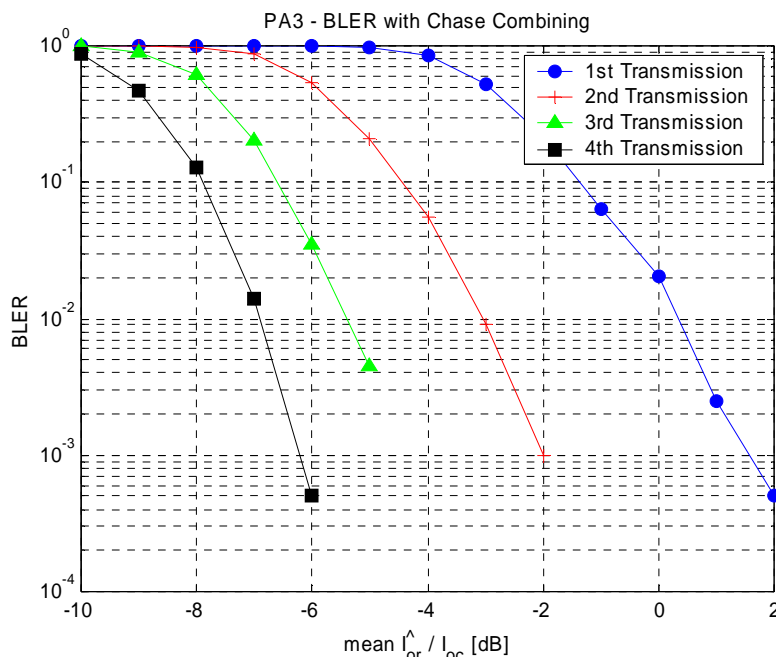

Figure 8.2.1.1.3: BLER for 384kbps bearer in a Pedestrian A 3kmph channel.

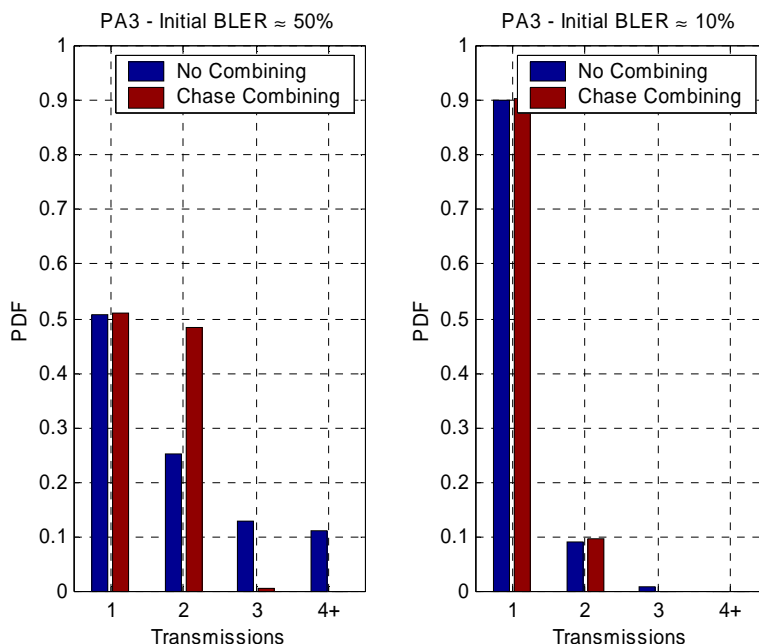

Figure 8.2.1.1.4: Delay distribution with first transmission BLER of 50% and 10% in a Pedestrian A 3kmph channel.

8.2.1.2 Hybrid ARQ Efficiency

In this section results demonstrating the efficiency of hybrid ARQ are presented and the number of transmissions required to support the 384 kbps bearer at its most efficient operating point is established.

In Figure 8.2.1.2.1 the E_b/N_0 per uncoded bit required for error free transmission is plotted against the mean received C/I per antenna branch per transmission. It can be seen that there is a gain from using hybrid ARQ with chase combining over that of no combining as the curve minimum is approximately 1dB lower in the former case. It can however also be seen that in order to obtain the most efficient performance from both chase combining and no combining the operating points in terms of received C/I are approximately 5dB apart.

This is demonstrated more clearly in Figure 8.2.1.2.2 where the plots of Figure 8.2.1.2.1 are inverted and translated into the linear domain to show the relative link capacity between hybrid ARQ with and without chase combining. From this figure it can be seen that when operating at the most efficient link C/I with and without chase combining (approximately -2dB with no combining and approximately -7dB with chase combining in this scenario), a link capacity gain of the order of 29% can be expected in a Pedestrian A 3kmph channel. By comparing the locations of the link capacity peaks with and without chase combining with Figure 8.2.1.1.2 and Figure 8.2.1.1.3 we observe that without chase combining the optimum capacity is achieved with approximately 1.25 transmissions on average and an initial transmission BLER of approximately 20%. However in the case of chase combining the optimum link capacity is achieved with approximately 3 transmissions and an initial transmission BLER of close to 100% and only falling to 20% after 3 transmissions.

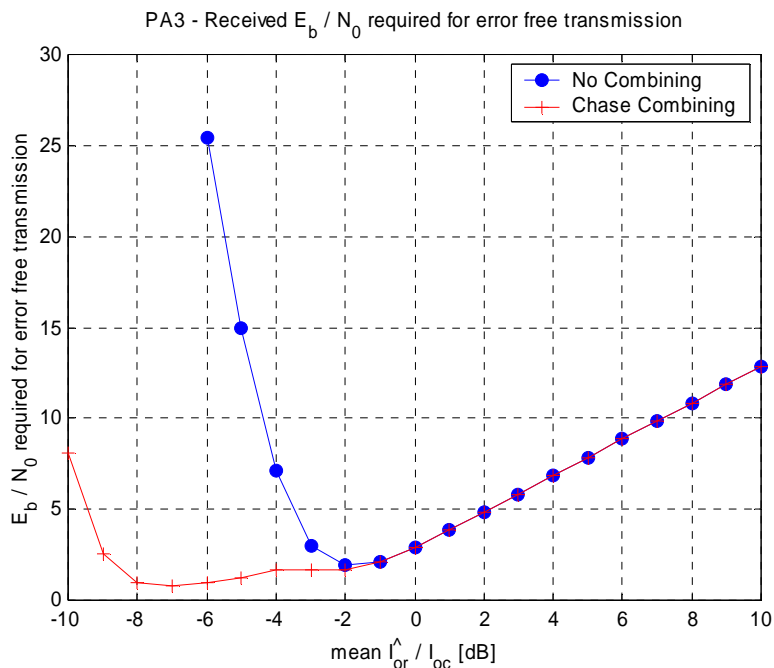

Figure 8.2.1.2.1: Energy per bit required for error free transmission in a Pedestrian A 3kmph channel.

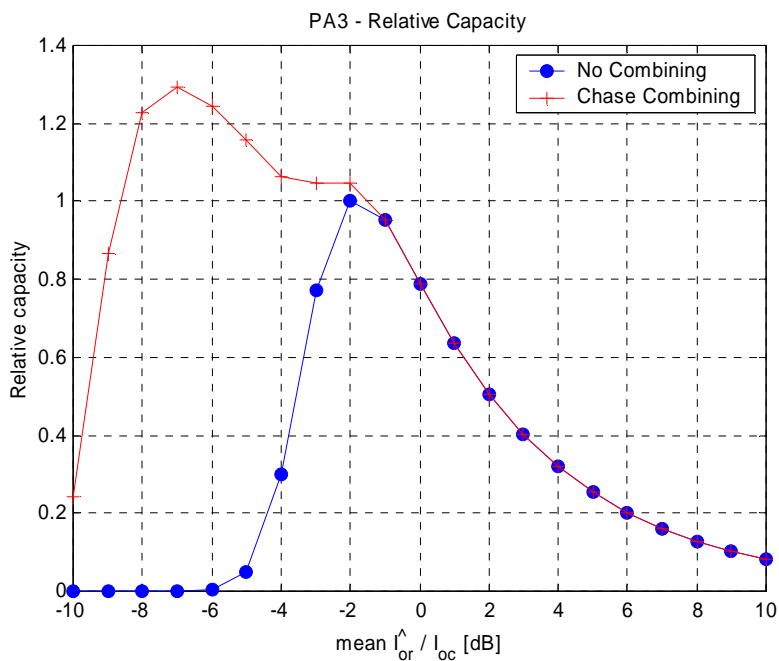

Figure 8.2.1.2.2: Relative capacity with and without chase combining in a Pedestrian A 3kmph channel.

- 8.2.2 Complexity Evaluation <UE and UTRAN impacts>
- 8.2.3 Downlink Signalling
- 8.2.4 Uplink Signalling
- 8.2.5 Compatibility with earlier Releases
- 8.3 Fast Allocation of Dedicated or Shared Resources
 - 8.3.1 Performance Evaluation
 - 8.3.2 Complexity Evaluation <UE and UTRAN impacts>
 - 8.3.3 Downlink Signalling
 - 8.3.4 Uplink Signalling
 - 8.3.5 Compatibility with earlier Releases
- 8.4 Physical Layer Enhancements
 - 8.4.1 Intra-frame Scrambling Code Hopping
 - 8.4.1.1 Performance Evaluation

In this section we present simulation results generated under the following conditions:

Chip Rate	3.84 Mcps
Burst Type	2
Modulation	QPSK
Spreading Factor	16
Channel Model	AWGN; each user is given a uniformly distributed random delay in the range [0, 4] chips. All users within the cell are assumed to be perfectly power controlled.
Channel Estimation	Perfect
FEC	1/3 and 3/4 rate Turbo code; iterative MAP decoding with 4 iterations
Physical channel structure	Each uplink user in the cell of interest is allocated one channelization code in the same 4 consecutive timeslots every frame (employing code hopping if applicable)
Intra-cell interferers	11 uplink users in addition to the user of interest (employing code hopping if applicable)
Inter-cell interference	1 user allocated a single SF 16 code in each timeslot; no code hopping is applied.
Detection	Users in the cell of interest are jointly detected using a linear MMSE receiver.

As described above all users in the cell of interest are allocated a distinct SF 16 channelization code over the same four consecutive timeslots. Scrambling codes ‘Code 0’, ‘Code 1’, ‘Code 2’ and ‘Code 3’, are applied to all bursts transmitted in first, second, third and fourth uplink timeslot respectively, where ‘Code 0’ to ‘Code 3’ are as defined in Annex A TR 25.223 [REF from 25.804]. An AWGN channel model is assumed in order to investigate the gains of code cycling in isolation i.e. without considering gains from interleaving in a fading channel.

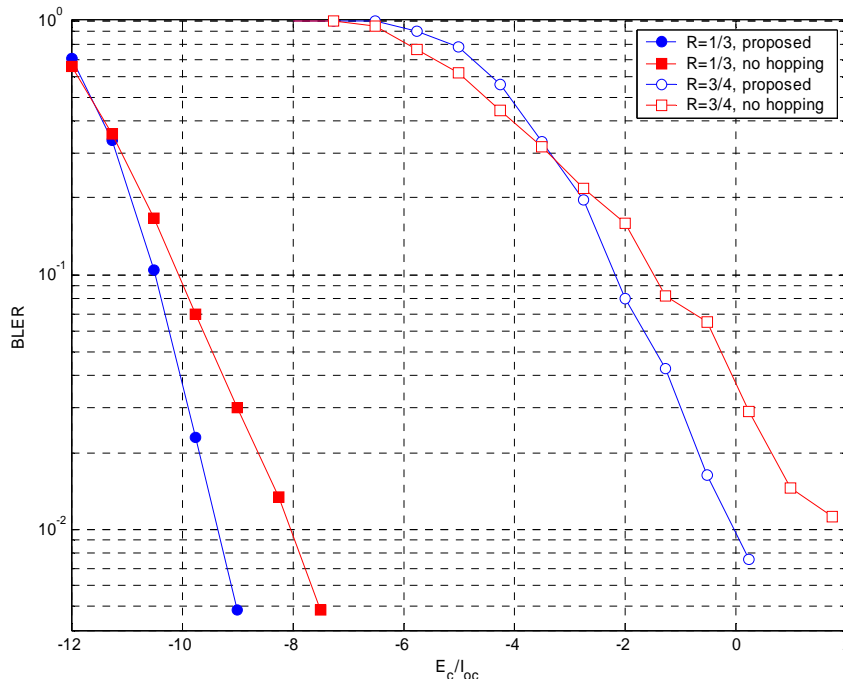

Figure 8.4.1.1.1: Performance in the presence of intra-cell interference only

Figure 8.4.1.1.1 compares the uplink block error rate performance with and without code hopping in the presence of intra-cell interference only. Observe that code hopping gives a reduction over 1 dB in the SNR required to achieve a BLER of 1% for both 1/3 rate and 3/4 rate turbo codes.

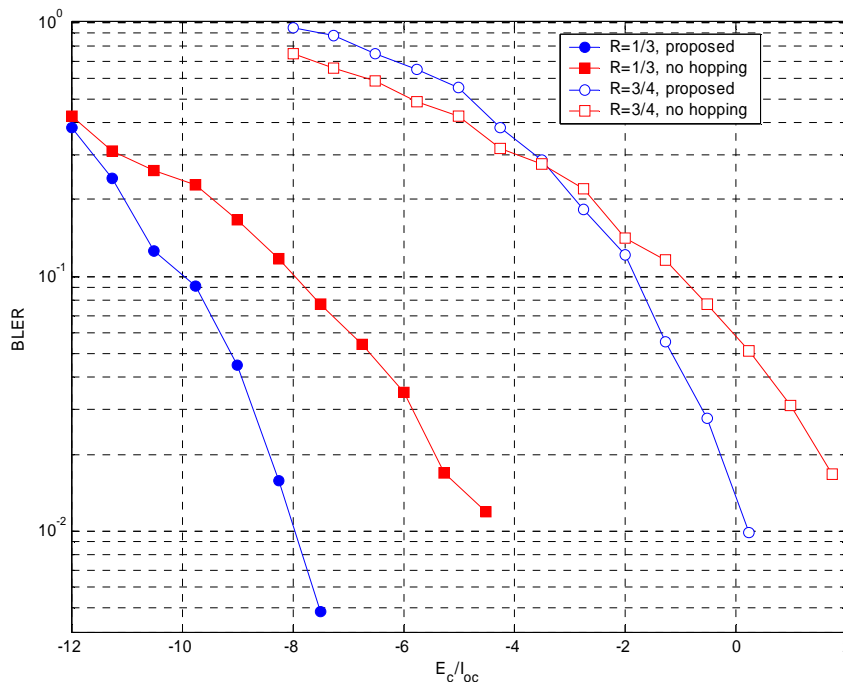

Figure 8.4.1.1.2: Performance in the presence of inter-cell and intra-cell interference

Figure 8.4.1.1.2 shows performance with and without code hopping in the presence of inter-cell interference and intra-cell interference. It is assumed that the inter-cell interferer does not employ code hopping. As such, the inter-cell interferer transmits a burst using the same scrambling code (randomly selected every frame) and the same channelization code (randomly selected every frame) every timeslot. The gain from code hopping is high as the inter-cell interference is highly correlated across the timeslots in a frame, if code hopping is not employed. Figure 8.4.1.1.2 shows that code hopping results in 2-4dB reduction in SIR required for 1% BLER.

We observe, from Figure 8.4.1.1.1 and Figure 8.4.1.1.2 that the gain from using code hopping is higher for the 1/3 rate turbo code compared to the 3/4 rate code. This is as expected since a more powerful code is able to better exploit interleaving.

8.4.1.2 Complexity Evaluation

As the receiver updates channel estimates every slot and detects the received signal slot by slot, intra-frame code hopping will not incur significantly more complexity. The scrambling code needs to be looked up or computed every slot as opposed to once per frame in the current system. The memory and time requirements for this operation is insignificant compared to the overall complexity of signal detection.

8.4.1.3 Compatibility with Earlier Releases

It is possible that users in a cell transmit a mixture of EU-TDD and non-EU-TDD bursts in the same timeslot. Each burst will be allocated a unique channelization code. The scrambling code used by the EU-TDD users will be different from the scrambling code used by the non-EU-TDD users. Thus the scrambling code set used for EU-TDD must have good cross correlation properties with the scrambling codes set defined in TS 25.223.

The inter-cell interference caused by EU-TDD bursts to neighbouring cells will be less severe over a radio frame in the sense that the interference will be randomised due to code hopping. However it should be guaranteed that users in neighbouring cells will not use the same or highly correlated scrambling codes in any timeslots. This may be accomplished either by using a new scrambling code set for EU-TDD or by network planning in the case when current scrambling code set is used.

9 Impacts to the Radio Network Protocol Architecture

9.1 Protocol Model

The proposed new MAC entity (see Chapter 7) is introduced to the Rel99/4/5/6 MAC sub-layer in the UE and UTRAN as for FDD (see [11]) and this covers the E-UCH specific functionality.

Figure 9.1.1 is an example protocol model for E-UCH. Reordering of E-UCH PDUs and demultiplexing of E-UCH PDUs to MAC-d PDUs is assumed to take place in the MAC-es of the serving RNC.

Transmissions and HARQ retransmissions of E-UCH PDUs, multiplexing of MAC-d PDUs to E-UCH PDUs and TFC selection are assumed to be performed by MAC-es/MAC-e in the UE.

Control of Hybrid ARQ and scheduling functions (control of UE access and resource assignment to E-UCH) is assumed to be provided by MAC-e in the Node B.

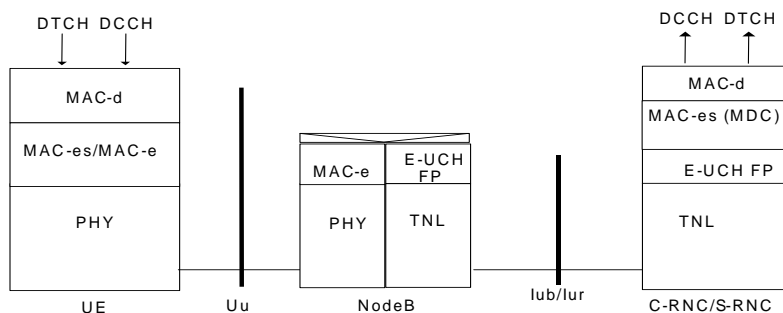

Figure 9.1.1: Example of protocol model for E-UCH transport channel

9.2 Introduction of new MAC functionality

New MAC functionality for E-UCH is realised via new MAC entities referred to as MAC-es/MAC-e. The introduction of a new MAC entity has an impact on TS25.321 [4]. It is assumed that much of the E-DCH functionality introduced in Rel6 for FDD will be re-used (and modified where appropriate) for the TDD E-UCH.

9.2.1 Introduction of an enhanced uplink transport channel (E-UCH)

The support of the uplink enhancements, considered in RAN WG1 for TDD, requires the introduction of a new enhanced uplink transport channel, called E-UCH. The E-UCH provides the same services/functionality to higher layers (i.e. to MAC-d) as is provided by the E-DCH defined for FDD [11]; however no assumption is made concerning the use of dedicated physical channels (see section 6.1). The introduction of E-UCH has no impact on MAC-c/sh or MAC-hs. A new connection is added between MAC-d and MAC-es/MAC-e.

Only one E-UCH transport channel is supported in the UE, hence multiplexing is required to concatenate several MAC-d flows into one E-UCH. Only one E-UCH is carried in a TTI and a single TTI of 10 ms is envisaged for 3.84Mcps TDD (for 1.28Mcps TDD support for a 5ms TTI may be preferred). One Transport Block per TTI should be assumed (as for FDD E-DCH [11]). There is one E-UCH per UE in the Node B and hence one MAC-e entity per UE in the Node B. There is one MAC-es entity in the RNC per UE. It must therefore be possible to multiplex several MAC-d flows onto the E-UCH.

9.2.2 HARQ functionality

Node B controlled Hybrid ARQ allows for rapid retransmissions of erroneously received data packets between UE and Node B. It is assumed that a stop and wait protocol will be employed as for FDD E-DCH. However, in order to maintain full arbitration of the enhanced uplink physical resources at Node-B MAC-e, a scheme employing synchronous retransmissions may not be desirable for TDD. Note this does not preclude the use of synchronous ACK/NACK signalling.

The absence of support for soft handover in TDD may enable procedures in the UE and Node B, and their associated signalling, to be simplified.

9.2.3 Reordering entity

RLC expects in-sequence delivery. The re-ordering functionality is assumed to be provided by MAC-es, in the SRNC (see [11]).

There will be one reordering queue per logical channel (per MAC-es, i.e. per UE) as for FDD E-DCH.

The reordering is based on a specific TSN included in the MAC-es PDU and on Node-B tagging. For each MAC-es PDU, the SRNC receives the TSN originating from the UE. Additional mechanisms (e.g. timer-based and/or window-based) are up to SRNC implementation and should not be standardised.

9.2.4 Control of Radio Resources

In Rel5 TFC selection in the UE is performed in accordance with the priorities (logical channel priority) indicated by RRC. For FDD E-DCH the Node B controls the subset of TFCs which may be used by the UE but all other radio resources remain controlled by the RNC.

For TDD E-UCH it is envisaged that the RNC will assign a pool of radio resources to a Node B for E-UCH and the Node B will then control allocation of resources from this pool to UEs (in the same manner as MAC-hs for HS-DSCH resources). This pool of resources would consist of a set of timeslots and codes that are to be used for E-UCH. It is therefore proposed that the Node B controls allocation of codes, timeslots, maximum transmission rate/highest TFC, duration of transmission, and desired signal power level to be used by the UE.

New signalling employed between peer MAC-e entities to effect control of enhanced uplink radio resources would include:

- (Serving cell Node B → UE) scheduling/allocation information

- (see [11],[9], it is envisaged that the FDD E-AGCH concept can be reused, with new parameters carried for TDD E-UCH)
- (Serving cell Node B → UE) H-ARQ ACK/NACK indication
 - cf: E-HICH for FDD E-DCH
- (UE → Serving cell Node B) provision of up-to-date information for use by the scheduler

9.3 RLC

Since the E-UCH is intended to transport dedicated logical channels, layers above the MAC layer are kept as per Rel99/4/5/6 (and as for FDD E-DCH [9]).

9.4 RRC

To support the uplink enhancements, required new signaling will need to be added to the RRC specification TS25.331 [5] to indicate parameters pertaining to the resources that may be assigned for the support of E-UCH and to support their setup and reconfiguration.

10 Impacts to Iub/Iur Protocols

10.1 Impacts on Iub/Iur Application Protocols

Enhancements considered for the uplink transport channels like Node B scheduling and Node B controlled HARQ will have an impact on the Iub/Iur application protocols, RNSAP and NBAP, TS25.423 [13] and TS25.433 [12] respectively.

To support enhanced uplink channels, application protocol procedures for setup, addition, reconfiguration and deletion of related radio links will have to be supported. This will very likely have an impact on Common NBAP procedures (e.g. Radio Link Setup), Dedicated NBAP procedures (e.g. Radio Link Reconfiguration) and corresponding RNSAP procedures. And as in the HSDPA case, CRNC will need to allocate and signal resources (e.g. codes and timeslots) to the Node B. In addition, the scheduling performed by serving Node B only is decentralized, and only limited information is available. To improve the accuracy of the scheduling, some communication between the RNC and Node Bs and possibly between different RNCs might be necessary. For the efficient scheduling, certain changes in NBAP Common Measurement and related RNSAP Global procedures might be required.

10.2 Impacts on Frame Protocol over Iub/Iur

The introduction of a new Frame Protocol for the enhanced uplink channels across Iub/Iur interface needs to be considered. Alternatively the current DCH or USCH FP could be enhanced, e.g. new IEs or Control Frames could be defined.

11 Conclusions and Recommendations

11.1 Conclusions

In the study of “Uplink Enhancements for UTRA TDD”, the following techniques have been evaluated:

- Node B controlled rate scheduling
- Node-B controlled physical resource scheduling
- Hybrid ARQ

- Higher order modulation
- Intra-frame code hopping

In addition, associated power control schemes and physical channel structures/alternatives have been considered.

Simulation of the effects on packet delay afforded through Node-B scheduling indicate that for delay-sensitive traffic such as gaming, the number of supported users at a given quality of service may be increased by approximately 50% when compared to a system with Release-5-like scheduling and ACK/NACK delays.

Packet call throughput gains are highly dependent upon the statistics of the traffic and in particular the mean packet call duration. For the gaming traffic model, with a long packet call duration of 5 seconds, packet call throughput was seen to increase by 10-15% through Node-B scheduling alone. However, this gain was seen to rise to 50% when the mean packet call time was reduced to 500ms. User experience is expected to be significantly improved via Node-B scheduling for traffic with short packet call times.

For TDD, the presence of limited code resources on the uplink requires that the Node-B scheduler has arbitration of the physical resources (code and timeslots) used for enhanced uplink amongst users. Scheduling strategies may vary depending upon the nature of the services offered and the traffic types carried. Thus, the system will benefit from an ability to allocate resources for long or short (i.e. 1 TTI) periods of time.

Simulation of hybrid ARQ has shown system throughput gains of the order of 30% for chase combining in a pedestrian-A channel for 3.84Mcps TDD. Incremental redundancy was not simulated.

For 3.84Mcps TDD, higher order modulation, of which only 8PSK has been studied, has been found to cause a loss in link performance compared to multi-code transmission with QPSK using greater code resources, but reveals a gain in link performance when compared with QPSK at high coderates using equal code resources. Due to the fact that TDD users share a cell-specific scrambling code, OVSF code resources must be shared amongst users and hence these link gains apply, especially in cases of high load. System simulations for a full buffer traffic model and round-robin scheduler show an increase in sector throughput of 10-15% when 8-PSK formats are enabled.

PAR is not worsened by the introduction of 8-PSK and has in-fact shown a small reduction when compared to an equivalent number of QPSK codes. Restriction of the enhanced uplink transmissions to use only a single channelisation code per UE (8-PSK or QPSK) would facilitate a reduction in PAR of approximately 2dB when compared to 2-codes using QPSK, typical of a release 5 UE. This would require that legacy physical channels are not allowed to be transmitted from a given UE together with enhanced uplink transmission within the same timeslot. Note this does not preclude transmission of legacy channels within the frame.

Intra-frame code hopping has been studied for 3.84Mcps TDD in order to ascertain the benefits of code diversity for short-code systems in a multi-user environment. Link gains of 1dB have been observed for intra-cell interference only, and 2-4dB in the presence of significant inter-cell interference.

A single static TTI of 10ms has been considered for 3.84Mcps TDD. A TTI of 5ms may be more appropriate for 1.28Mcps TDD due to alignment with the existing 5ms sub-frame structure.

Complexity and backwards compatibility aspects of the enhancements have been studied where appropriate and comments from RAN2 and RAN3 on their respective areas have also been taken into account in the TR. It is expected that the enhancements may be introduced into the specifications without undue impact on features present in earlier releases and with manageable complexity.

11.2 Recommendations

In light of the findings in this document, it is proposed that the following uplink enhancements are incorporated into the specifications; the work being continued via the creation of a suitable work item:

- Node B controlled rate scheduling
- Node-B controlled physical resource scheduling
- Hybrid ARQ
- Higher order modulation (including 8-PSK at a minimum)
- Intra-frame code hopping (for 3.84Mcps TDD, 1.28Mcps TDD FFS)

Annex A: Simulation Assumptions and Results

A.1 Link Simulation Assumptions

A.2 Link Simulation Results

A.3 System Simulation Assumptions

A.4 System Simulation Results

A.5 Traffic Models

Annex B: Change history

Change history							
Date	TSG #	TSG Doc.	CR	Rev	Subject/Comment	Old	New
08-2003	RAN1#33	R1-03-0940			Initial TR skeleton presented for discussion	x	0.0.1
02-2004	RAN1#36	R1-04-0175			Inclusion of R1-030978 – Text proposal on reference, definitions and abbreviations	0.0.1	0.2
02-2004	RAN1#36	R1-040383			Removed revision marks	0.0.2	0.1.0
05-2004	RAN1#37	R1-040410			Inclusion of R1-040176 Text proposal on Reference Techniques in Earlier Releases and HARQ as Candidate Technique for TDD UL Enhancements	0.1.0	0.1.1
05-2004	RAN1#37	R1-040639			Removed revision marks	0.1.1	0.2.0
08-2004	RAN1#38	R1-040819			Inclusion of R1-040591 Text proposal for Node-B Scheduling for TDD Enhanced Uplink and R1-040592 Text proposal 25.804 Section 7	0..2.0	0.2.1
08-2004	RAN1#38	R1-041041			Removed revision marks	0.2.1	0.3.0
11-2004	RAN1#38 RAN3#44	R1-041319			Inclusion of R1-040991 Intra-frame Code Hopping for EU-TDD, R1-040992 HARQ performance for TDD Enhanced Uplink, R1-01035 Power Control for TDD Enhanced Uplink and R3-041384 Text Proposal for RAN3 Impact for TDD Enhanced Uplink	0.3.0	0.3.1
11-2004	RAN1#38 RAN3#44	R1-041519			Editorial corrections to v3.0.1	0.3.1	0.3.2
11-2004	RAN1#38 RAN3#44	R1-041539			Removal of revision marks	0.3.2	1.0.0
02-2005	RAN1#40 RAN2#46	R1-050212			Inclusion of R1-050160, "8-PSK for TDD Enhanced Uplink and text proposal for TR25.804", R1-050162, "Draft Text on Conclusions and Recommendations for the TDD Enhanced", R1-050190, "Text proposal on Node-B scheduling for TR 25.904", R2-050316, "Text for Chapters 7, 9 and 10 of TR 25.804 Feasibility",	1.0.0	1.0.1
02-2005	RAN1#40 RAN2#46	R1-050229			Removal of revision marks. Editorial/ formatting correction	1.0.1	1.1.0
02-2005	RAN1#40				Removal of revision marks	1.1.0	2.0.0