

3GPP TSG RAN Meeting #21
Frankfurt, Germany, 16 - 19 September 2003

RP-030474

TSG-RAN Working Group 4 (Radio) meeting #28
Sophia Antipolis, France, 18th – 22nd August 2003

R4-030833

Title: Reply LS on the material to be submitted to ITU-R WP8F#11 for Revision 4 of Recommendation ITU-R M.1457

Source: RAN WG4
To: ITU-R Ad Hoc
Cc: RAN

Contact: **Claudio Guerrini**
Telecom Italia
claudio.guerrini@telecomitalia.com

RAN4 would like to thank ITU-R Ad Hoc for the LS on the material to be submitted to ITU-R WP8F#11 for Revision 4 of Recommendation ITU-R M.1457.

RAN4 has reviewed the LS and the attached annexes.

As a first input, RAN4 kindly asks to take into account the following versions of the specifications under RAN4 responsibility, as listed below for both FDD and TDD component:

IMT-2000 CDMA Direct Spread component (FDD component):

- 25.101 v3.14.0
- 25.101 v4.8.0
- 25.101 v5.7.0
- 25.101 v6.1.0
- 25.104 v3.12.0
- 25.104 v4.7.0
- 25.104 v5.7.0
- 25.104 v6.2.0
- 25.106 v4.6.0
- 25.106 v5.5.0
- 25.113 v3.5.0
- 25.113 v4.4.0
- 25.113 v5.4.0
- 25.133 v3.13.0
- 25.133 v4.8.0
- 25.133 v5.6.0
- 25.133 v6.1.0

- 25.141 v4.8.0
- 25.141 v6.2.0
- 25.141 v5.7.0
- 25.143 v4.8.0
- 25.143 v5.5.0
- 34.124 v.3.4.0
- 34.124 v.4.2.0
- 34.124 v5.3.0

IMT-2000 CDMA TDD (TDD component)

- 25.102 v3.12.0
- 25.102 v4.7.0
- 25.102 v5.5.0
- 25.105 v3.13.0
- 25.105 v4.7.0
- 25.105 v5.4.0
- 25.113 v3.5.0
- 25.113 v4.4.0
- 25.113 v5.4.0
- 25.123 v3.13.0
- 25.123 v4.9.0
- 25.123 v5.3.0
- 25.142 v3.13.0
- 25.142 v4.8.0
- 25.142 v5.5.0
- 34.124 v.3.4.0
- 34.124 v.4.2.0
- 34.124 v5.3.0

Moreover, in RAN4's opinion, it is up to RAN plenary to establish the level of completion for ITU-R submission of the following WIs:

- UMTS850
- DS CDMA introduction in the 800MHZ Band
- UMTS 1.7/2.1

Depending on RAN's decision on these specific WIs, the referenced version of the previously listed specifications has to be updated. For this specific issue, RAN4 proposes a new version of the overview for UTRA FDD component, hereby attached.

5.1 IMT-2000 CDMA Direct Spread

5.1.1 Overview of the radio interface

5.1.1.1 Introduction

The IMT-2000 radio-interface specifications for CDMA Direct Spread technology are developed by a partnership of SDOs (see Note 1). This radio interface is called Universal Terrestrial Radio Access (UTRA) FDD or Wideband CDMA (WCDMA).

NOTE 1 – Currently, these specifications are developed within the third generation partnership project (3GPP) where the participating SDOs are the Association of Radio Industries and Businesses (ARIB), China Wireless Telecommunication Standard Group (CWTS), the European Telecommunications Standards Institute (ETSI), T1 (Alliance for Telecommunications Industry Solutions (ATIS) Standards Committee T1), Telecommunications Technology Association (TTA) and Telecommunication Technology Committee (TTC).

These radio-interface specifications have been developed with the strong objective of harmonization with the TDD component (see § 5.3) to achieve maximum commonality. This was achieved by harmonization of important parameters of the physical layer. Furthermore, a common set of protocols in the higher layers is specified for both FDD and TDD.

In the development of this radio interface the CN specifications are based on an evolved GSM-MAP. However, the specifications include the necessary capabilities for operation with an evolved ANSI-41-based CN.

The radio-access scheme is Direct-Sequence CDMA (DS-SS) with information spread over approximately 5 MHz bandwidth using a chip rate of 3.84 Mchip/s. The radio interface is defined to carry a wide range of services to efficiently support both circuit-switched services (e.g. PSTN- and ISDN-based networks) as well as packet-switched services (e.g. IP-based networks). A flexible radio protocol has been designed where several different services such as speech, data and multimedia can simultaneously be used by a user and multiplexed on a single carrier. The defined radio-bearer services provide support for both real-time and non-real-time services by employing transparent and/or non-transparent data transport. The quality of service (QoS) can be adjusted in terms such as delay, bit error probability, and frame error ratio (FER).

The radio-interface specification includes enhanced features for High-Speed Downlink Packet Access (HSDPA), allowing for downlink packet-data transmission with peak data rates exceeding 8 Mbit/s and simultaneous high-speed packet data and other services such as speech on the single carrier.

WCDMA was originally specified for the IMT-2000 core bands identified in WRC-1992 and using 1920-1980 MHz as uplink and 2110-2170 MHz as downlink. In WRC-2000 additional spectrum for IMT-2000 was identified and subsequently as a complement to 3GPP Release99 the relevant specifications have been updated to also include the 1900 MHz, 1800 MHz, 850 MHz, and 800 MHz bands as well as a pairing of parts, or whole, of 1710-1770 MHz as uplink with whole, or parts, of 2110-2170 MHz as downlink. In addition a more general study has been performed considering the viable deployment of WCDMA in additional and diverse spectrum arrangements.

5.1.1.2 Radio access network architecture

The overall architecture of the radio access network is shown in Fig. 3.

The architecture of this radio interface consists of a set of radio network subsystems (RNS) connected to the CN through the Iu interface. An RNS consists of a radio network controller (RNC) and one or more entities called Node B. Node B is connected to the RNC through the Iub interface. Each Node B can handle one or more cells. The RNC is responsible for the handover decisions that require signalling to the user equipment (UE). In case macro diversity between different Node Bs is to be supported, the RNC comprises a combining/splitting function to support this. Node B can comprise an optional combining/splitting function to support macro diversity within a Node B. The RNCs of the RNS can be interconnected through the Iur interface. Iu and Iur are logical interfaces, i.e. the Iur interface can be conveyed over a direct physical connection between RNCs or via any suitable transport network.

Figure 4 shows the radio interface protocol architecture for the radio access network. On a general level, the protocol architecture is similar to the current ITU-R protocol architecture as described in Recommendation ITU-R M.1035. Layer 2 (L2) is split into the following sub-layers; radio link control (RLC), medium access control (MAC), Packet Data Convergence Protocol (PDCP) and Broadcast/Multicast Control (BMC). Layer 3 (L3) and RLC are divided into control (C-plane) and user (U-plane) planes. In the C-plane, L3 is partitioned into sub-layers where the lowest sub-layer, denoted as radio resource control (RRC), interfaces with L2. The higher-layer signalling such as mobility management (MM) and call control (CC) are assumed to belong to the CN. There are no L3 elements in this radio interface for the U-plane.

FIGURE 3
Radio access network architecture
(Cells are indicated by ellipses)

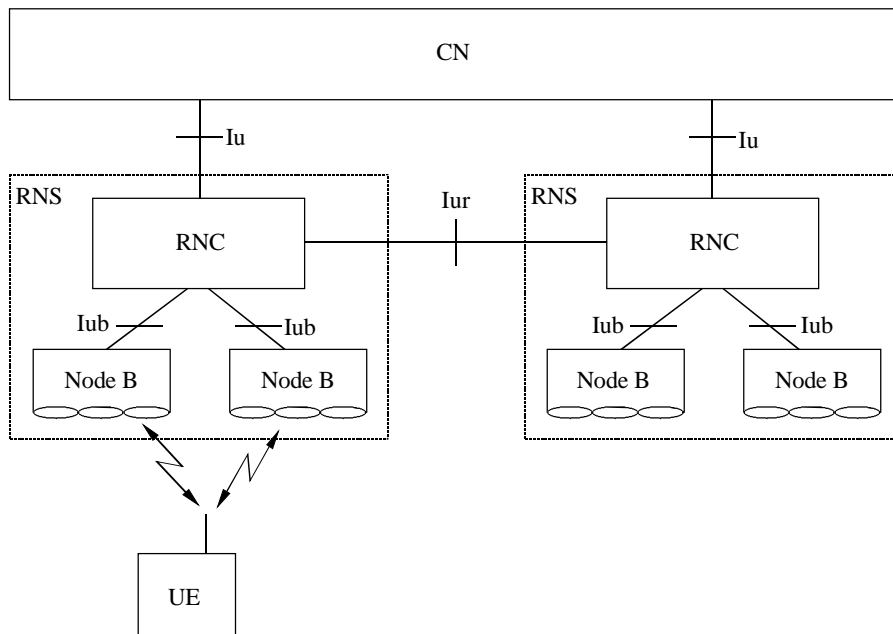

1457-03

Each block in Fig. 4 represents an instance of the respective protocol. Service access points (SAPs) for peer-to-peer communication are marked with circles at the interface between sub-layers. The SAP between MAC and the physical layer provides the transport channels. A transport channel is characterized by how the information is transferred over the radio interface (see Section 5.1.1.3.1 for an overview of the types of transport channels defined). The SAPs between RLC and the MAC sub-layer provide the logical channels. A logical channel is characterized by the type of information

that is transferred over the radio interface. The logical channels are divided into control channels and traffic channels. The different types of logical channels are not further described in this overview. In the C-plane, the interface between RRC and higher L3 sub-layers (CC, MM) is defined by the general control (GC), notification (Nt) and dedicated control (DC) SAPs. These SAPs are not further discussed in this overview.

Also shown in Fig. 4 are connections between RRC and MAC as well as RRC and L1 providing local inter-layer control services (including measurement results). An equivalent control interface exists between RRC and the RLC sub-layer. These interfaces allow the RRC to control the configuration of the lower layers. For this purpose separate control SAPs are defined between RRC and each lower layer (RLC, MAC, and L1).

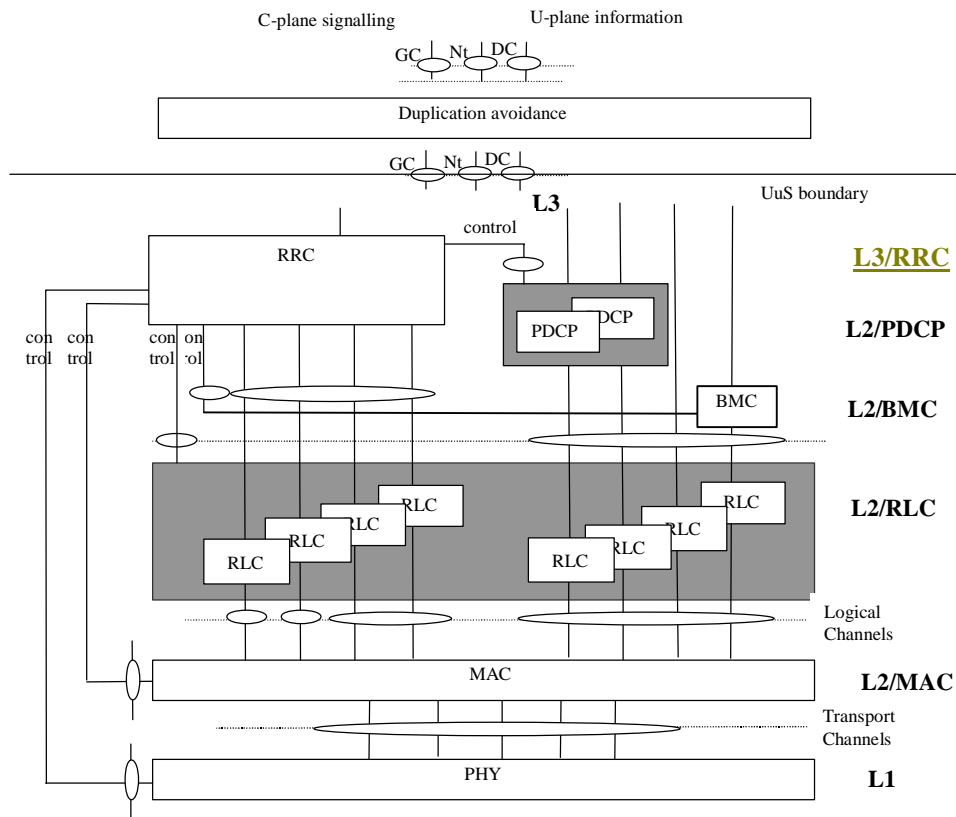

FIGURE 4

Radio interface protocol architecture of the RRC sublayer, (L2 and L1)

Figure 5 shows the general structure and some additional terminology definitions of the channel formats at the various sub-layer interfaces indicated in Fig. 4. The Figure indicates how higher layer service data units (SDUs) and protocol data units (PDUs) are segmented and multiplexed to transport blocks to be further treated by the physical layer (e.g. CRC handling). The transmission chain of the physical layer is exemplified in the next section.

5.1.1.3 Physical layer

5.1.1.3.1 Transport Channels

Transport channels are the services offered by the physical layer to MAC and higher layers. The general classification of transport channels is into two groups:

- Common transport channels where there is a need for explicit UE identification when a particular UE is addressed or a particular group of UEs are addressed.
- Dedicated transport channels where a UE is implicitly identified by the physical channel, i.e. code and frequency.

Common transport channel types are:

- **Random Access Channel (RACH)**

A contention based uplink channel used for transmission of relatively small amounts of data, e.g. for initial access or non-real-time dedicated control or traffic data.

– **Common Packet Channel (CPCH)**

A contention based uplink channel used for transmission of bursty data traffic. The common packet channel is shared by the UEs in a cell and therefore, it is a common resource. The CPCH is fast power controlled.

– **Forward Access Channel (FACH)**

A common downlink channel without closed-loop power control used for transmission of relatively small amount of data.

– **Downlink Shared Channel (DSCH)**

A downlink channel shared by several UEs carrying dedicated control or traffic data.

– **High-speed Downlink Shared Channel (HS-DSCH)**

A downlink channel served by several UEs carrying dedicated control or traffic data. HS-DSCH offers the possibility for high-speed downlink packet access through the support of higher-order modulation, adaptive modulation and coding, fast channel-dependent scheduling, and hybrid ARQ with soft combining.

– **Broadcast Channel (BCH)**

A downlink channel used for broadcast of system information into an entire cell.

– **Paging Channel (PCH)**

A downlink channel used for broadcast of control information into an entire cell allowing efficient UE sleep mode procedures. Currently identified information types are paging and notification. Another use could be UTRAN notification of change of BCCH information.

Dedicated transport channel types are:

– **Dedicated Channel (DCH)**

A channel dedicated to one UE used in uplink or downlink.

On each transport channel, a number of *Transport Blocks* are delivered to/from the physical layer once every *Transmission Time Interval* (TTI). To each transport channel, there is an associated *Transport Format* or set of transport formats. The transport format describes the physical properties of the transport channel, such as the TTI, the number of transport blocks per TTI, the number of bits per transport blocks, the coding scheme and coding rate, and the modulation scheme.

5.1.1.3.2 Physical layer functionality and building blocks

The physical layer includes the following functionality:

- error detection on transport channels and indication to higher layers;
- forward error correction (FEC) encoding/decoding of transport channels;
- multiplexing of transport channels and demultiplexing of coded composite transport channels;
- rate matching;
- mapping of coded composite transport channels on physical channels;
- data modulation and demodulation of physical channels;
- spreading and de-spreading of physical channels;
- radio characteristics measurements including FER, Signal-to-Interference (SIR), Interference Power Level, etc., and indication to higher layers;
- frequency and time (chip, bit, slot, frame) synchronization;

- power weighting and combining of physical channels;
- closed-loop power control;
- RF processing;
- support of UE positioning methods;
- beamforming;
- macro-diversity distribution/combining and soft handover execution.

Figure 6 gives the physical layer transmission chain for the DCH transport channel. The Figure shows how several transport channels can be multiplexed onto one or more dedicated physical data channels (DPDCH).

The cyclic redundancy check (CRC) provides for error detection of the transport blocks for the particular transport channel. The CRC can take the length zero (no CRC), 8, 12, 16 or 24 bits depending on the service requirements.

The transport block concatenation and code block segmentation functionality performs serial concatenation of those transport blocks that will be sent in one transmission time interval and any code block segmentation if necessary.

The types of channel coding defined are convolutional coding, turbo coding and no coding. Real-time services use only FEC encoding while non-real-time services uses a combination of FEC and ARQ. The ARQ functionality resides in the RLC sub-layer of Layer 2. The convolutional coding rates are 1/2 or 1/3 while the rate is 1/3 for turbo codes. The possible interleaving depths are 10, 20, 40 or 80 ms.

The radio frame segmentation performs padding of bits. The rate matching adapts any remaining differences of the bit rate so the number of outgoing bits fit to the available bit rates of the physical channels. Repetition coding and/or puncturing is used for this purpose.

The transport channel multiplexing stage combines transport channels in a serial fashion. This is done every 10 ms. The output of this operation is also called coded composite transport channels.

If several physical channels will be used to transmit the data, the split is made in the physical channel segmentation unit.

The downlink can use DTX on a slot-to-slot basis for variable rate transmission. The insertions could either be at fixed or at flexible positions.

For other transport-channel types, the physical-layer transmission chain is similar although not necessarily identical to that of DCH in Figure 6.

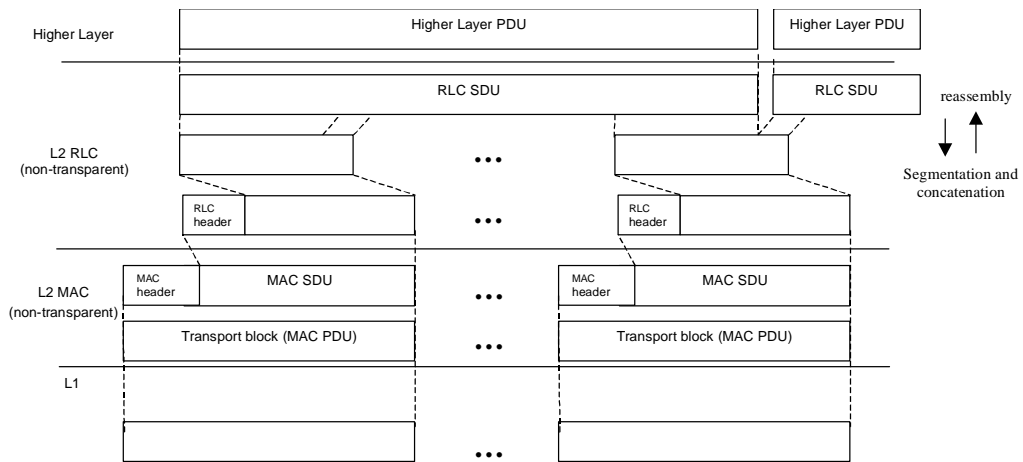

FIGURE 5

**Data flow for a service using a non-transparent RLC and non-transparent MAC
(see Sections 5.1.1.4.1-2 for further definitions of the MAC and RLC services
and functionality)**

FIGURE 6

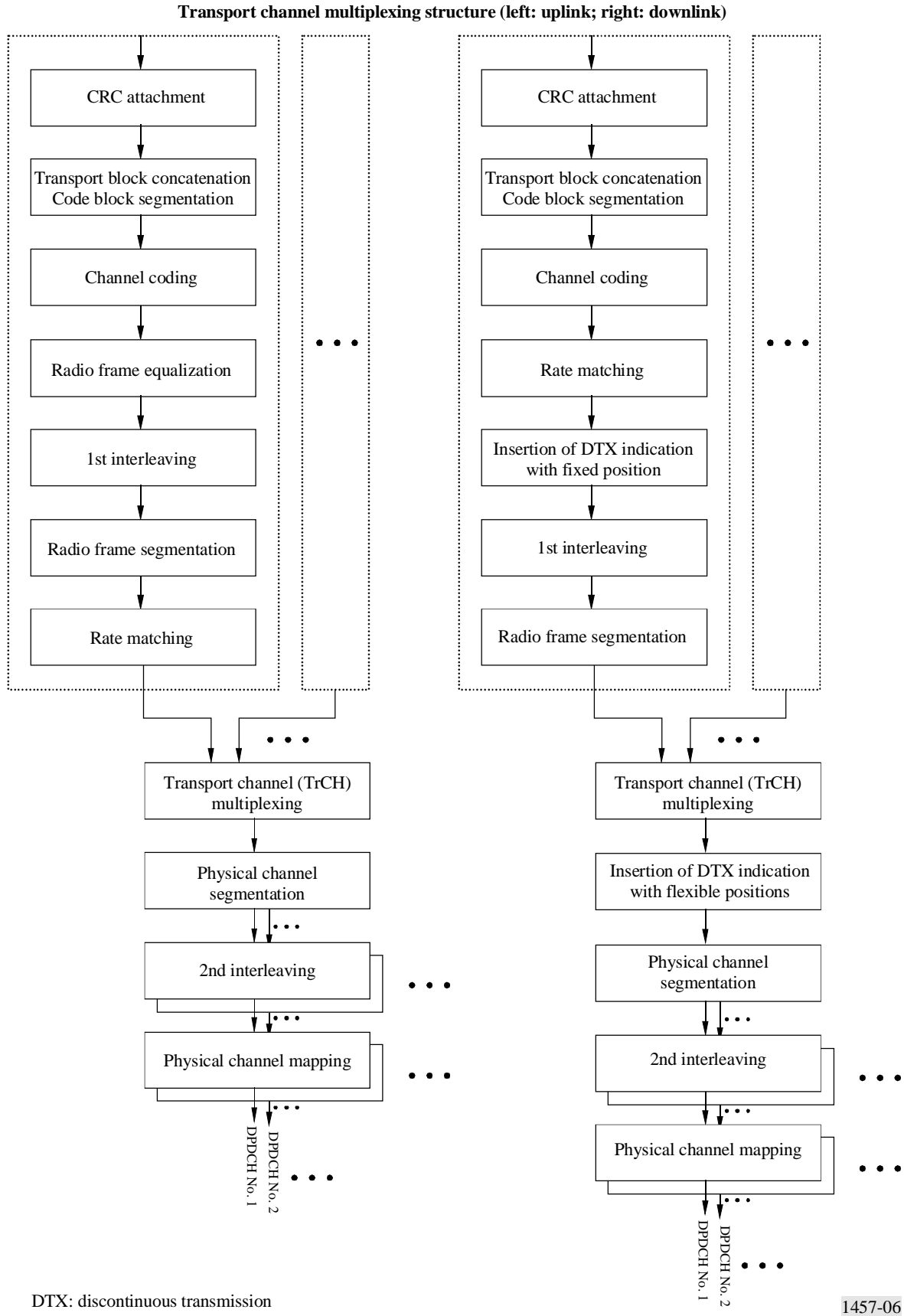

FIGURE 6
DCH transport channel multiplexing structure (left: uplink; right: downlink)

5.1.1.3.3 Transport channels to physical channel mapping

The transport channels are mapped onto the physical channels. Figure 7 shows the different physical channels and summarizes the mapping of transport channels onto physical channels. Each physical channel has its tailored slot content. The slot content for the uplink and downlink DPDCH/DPCCH, on to which the uplink and downlink DCH is mapped, is shown in Section 5.1.1.3.4.

5.1.1.3.4 Physical frame structure

The basic physical frame rate is 10 ms with 15 slots. Figure 8 shows the frame structure.

Figure 9 shows the content for a slot used by the DCH. The uplink physical channels DPDCH and DPCCH are I/Q multiplexed while the downlink channels are time multiplexed. The DPDCH, the channel where the user data is transmitted on, is always associated with a DPCCH containing Layer 1 control information. The transport format combination indicator (TFCI) field is used for indicating the demultiplexing scheme of the data stream. The TFCI field does not exist for combinations that are static (i.e. fixed bit rate allocations) or blind transport format detection is employed. The feedback information (FBI) field is used for transmit and site diversity functions. The transmit power control (TPC) bits are used for power control.

Transport Channels	Physical Channels
BCH	Primary Common Control Physical Channel (Primary CCPCH) (Downlink; 30 kbps fixed rate)
FACH	Secondary Common Control Physical Channel (Secondary CCPCH) (Downlink; Variable rate.)
PCH	Physical Random Access Channel (PRACH) (Uplink)
RACH	
CPCH	Physical Common Packet Channel (PCPCH) (Uplink)
DCH	Dedicated Physical Data Channel (DPDCH) (Downlink/Uplink)
	Dedicated Physical Control Channel (DPCCH) (Downlink/Uplink; Associated with a DPDCH)
DSCH	Physical Downlink Shared Channel (PDSCH) (Downlink)
HS-DSCH	Physical High-Speed-Downlink Shared Channel (PHSDSCH) (Downlink)
	Synchronization Channel (SCH) (Downlink; uses part of the slot of primary CCPCH; used for cell search)
	Common Pilot Channel (CPICH) (Downlink, used as phase reference for other downlink physical channels)
	Acquisition Indicator Channel (AICH) (Downlink; used to carry acquisition indicator for the random access procedure)
	Paging Indicator Channel (PICH) (Downlink; used to carry page indicators to indicate the presence of a page message on the PCH)
	Access Preamble Acquisition Indicator Channel (AP-AICH)*
	CPCH Status Indicator Channel (CSICH)*
	Collision-Detection/Channel-Assignment Indicator Channel (CD/CA-ICH)* (*Downlink, channels for CPCH access procedure)

FIGURE 7

Transport channels, physical channels and their mapping

FIGURE 8
Basic frame structure

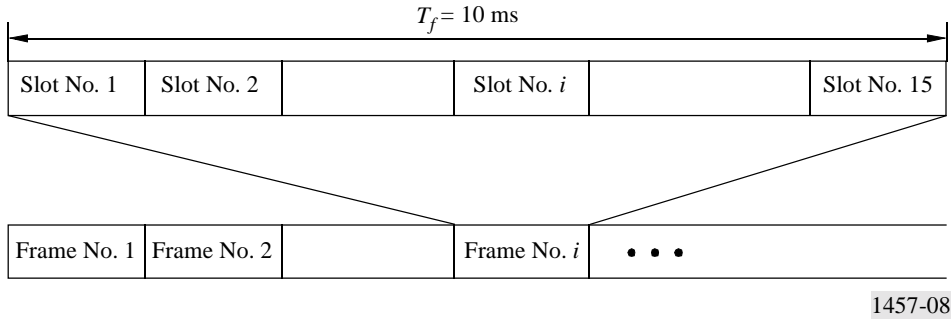

1457-08

FIGURE 8
Basic frame structure

FIGURE 9
The slot content for the DPDCH/DPCCH

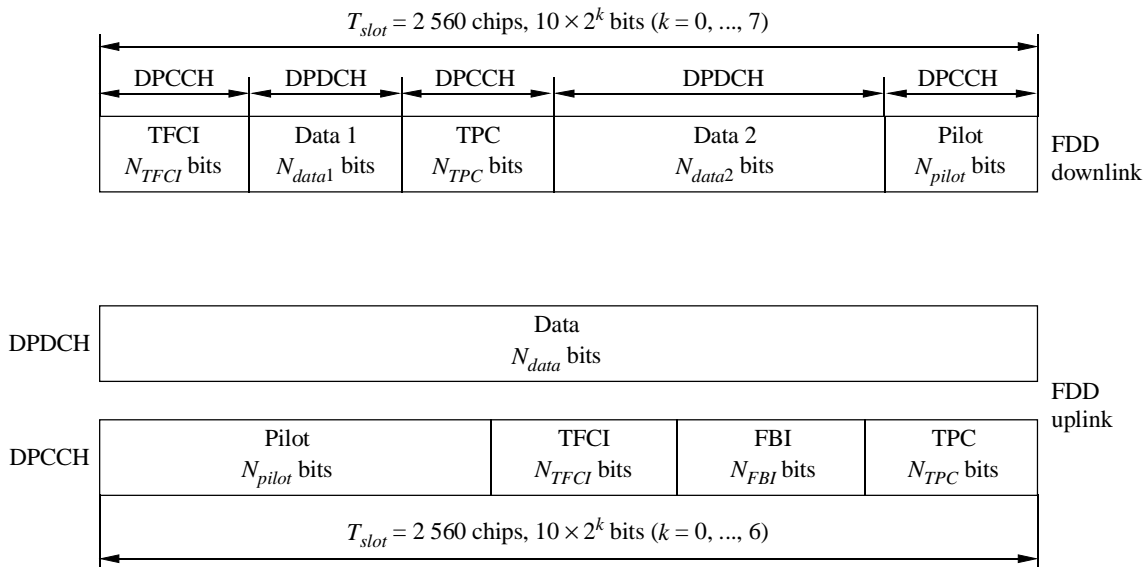

1457-09

For the uplink, the DPDCH bit rate can vary between 15 up to 960 kbit/s using spreading factors (SFs) (256 down to 4). To obtain higher bit rates for a user several physical channels can be used. The bit rate of the DPCCH is fixed to 15 kbit/s. For the downlink the DPDCH bit rate is variable between 15 up to 1 920 kbit/s with a SF ranging from 512 down to 4. Note that the symbol bit rate is equal to the channel bit rate for the uplink while it is half of the channel bit rate for the downlink.

A CPICH is defined. It is an unmodulated downlink channel, that is the phase reference for other downlink physical channels. There is always one primary CPICH in each cell. There may also be additional secondary CPICHs in a cell.

To be able to support inter-frequency handover as well as measurements on other carrier frequencies or carriers of other systems, like GSM, a compressed mode of operation is defined. The function is implemented by having some slots empty, but without deleting any user data. Instead the user data is transmitted in the remaining slots. The number of slots that is not used can be variable with a minimum of three slots (giving minimum idle lengths of at least 1.73 ms). The slots can be empty either in the middle of a frame or at the end and in the beginning of the consecutive frame. If and how often is controlled by the RRC functionality in Layer 3.

5.1.1.3.5 Spreading, modulation and pulse shaping

Uplink

Spreading consists of two operations. The first is the channelization operation, which transforms every data symbol into a number of chips, thus increasing the bandwidth of the signal. The number of chips per data symbol is called the SF. The second operation is the scrambling operation, where a scrambling code is applied to the spread signal.

In the channelization operation, data symbol on so-called I- and Q-branches are independently multiplied with a code. The channelization codes are orthogonal variable spreading factor (OVSF) codes that preserve the orthogonality between a user's different physical channels. With the scrambling operation, the resultant signals on the I- and Q-branches are further multiplied by complex-valued scrambling code, where I and Q denote real and imaginary parts, respectively. Note that before complex multiplication binary values 0 and 1 are mapped to +1 and -1, respectively. Figure 10 illustrates the spreading and modulation for the case of multiple uplink DPDCHs. Note that this figure only shows the principle, and does not necessarily describe an actual implementation. Modulation is dual-channel QPSK (i.e. separate BPSK on I- and Q-channel), where the uplink DPDCH and DPCCH are mapped to the I and Q branch respectively. The I and Q branches are then spread to the chip rate with two different channelization codes and subsequently complex scrambled by a UE specific complex scrambling code C_{scramb} . There are 2^{24} uplink-scrambling codes. Either short (256 chips from the family of S(2) codes) or long (38 400 chips equal to one frame length, gold code-based) scrambling codes is used on the uplink. The short scrambling code is typically used in cells where the BS is equipped with an advanced receiver, such as a multi-user detector or interference canceller whereas the long codes gives better interference averaging properties.

The pulse-shaping filters are root-raised cosine with roll-off $\alpha = 0.22$ in the frequency domain.

The modulation of both DPCCH and DPDCH is BPSK. The modulated DPCCH is mapped to the Q-branch, while the first DPDCH is mapped to the I-branch. Subsequently added DPDCHs are mapped alternatively to the I- or Q-branches.

Downlink

Figure 11 illustrates the spreading and modulation for the downlink DPDCH/DPCCH. Data modulation is QPSK where each pair of two bits are serial-to-parallel (S/P) converted and mapped to the I- and Q-branch respectively. The I- and Q-branch are then spread to the chip rate with the same channelization code C_{ch} (real spreading) and subsequently scrambled by the scrambling code C_{scramb} (complex scrambling).

The channelization codes are the same codes as used in the uplink that preserve the orthogonality between downlink channels of different rates and SFs. There are a total of $512 \times 512 = 262\,144$ scrambling codes, numbered 0 to 262 143. The scrambling codes are divided into 512 sets each of a primary scrambling code and 511 secondary scrambling codes. Each cell is allocated one and only one primary scrambling code. The primary CCPCH is always transmitted using the primary

scrambling code. The other downlink physical channels can be transmitted with either the primary scrambling code or a secondary scrambling code from the set associated with the primary scrambling code of the cell.

The pulse-shaping filters are root-raised cosine with roll-off $\alpha = 0.22$ in the frequency domain.

Downlink spreading for downlink physical channels other than the downlink DPCH is very similar. For the physical channel to which HS-DSCH is mapped, higher-order data modulation can be used in addition to QPSK.

FIGURE 10
Spreading/modulation for uplink DPDCH/DPCCH

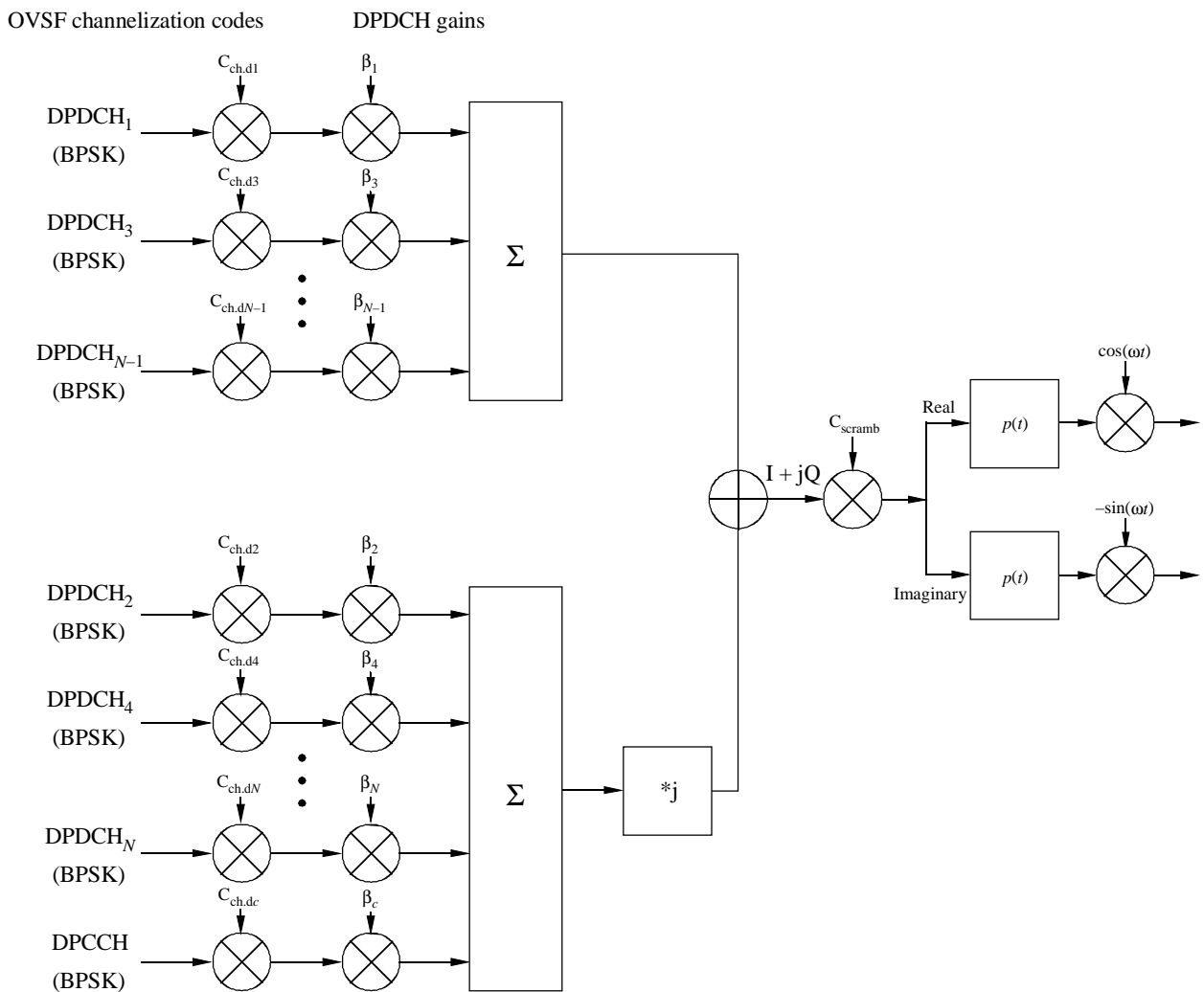

1457-10

FIGURE 11
Spreading/modulation for downlink DPDCH/DPCCCH

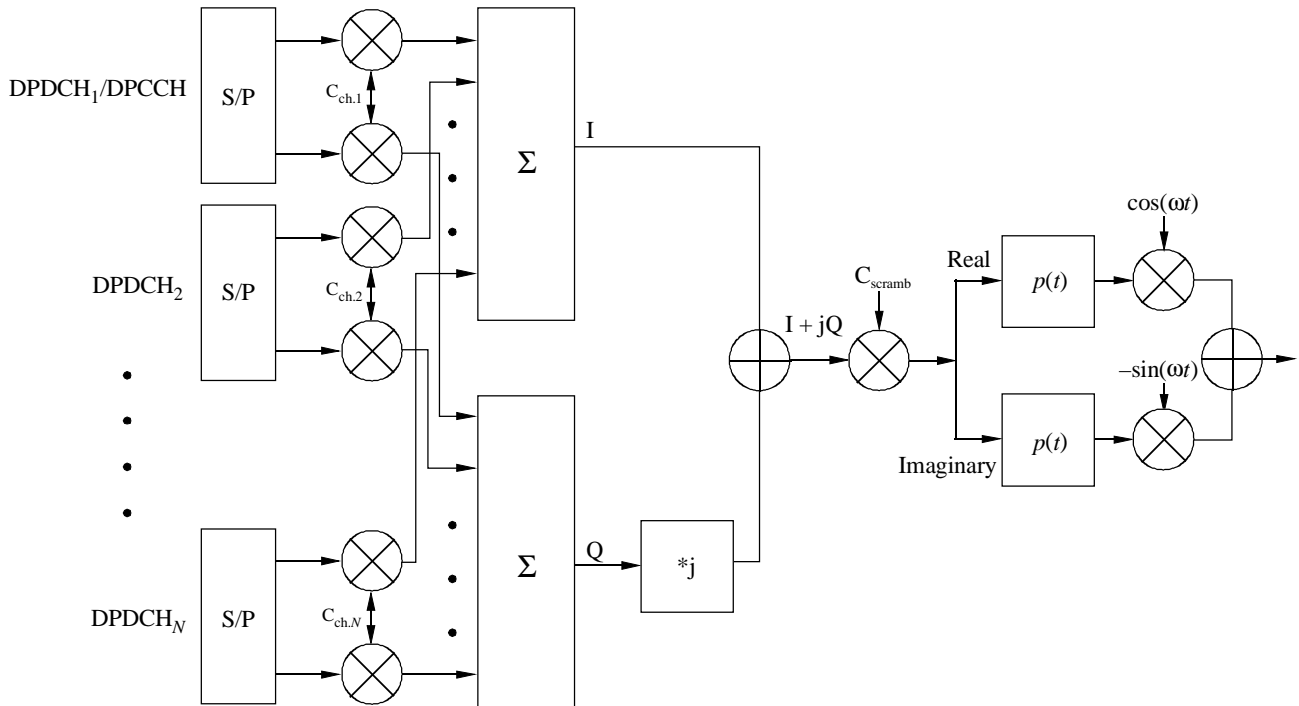

1457-11

5.1.1.4 Layer 2

5.1.1.4.1 MAC sub-layer

The MAC sub-layer is responsible for the handling of the data streams coming from the RLC and RRC sub-layers. It provides an unacknowledged transfer mode service to the upper layers. The interface to the RLC sub-layer is through logical channel service access points. It also re-allocates radio resources on request by the RRC sub-layer as well as provides measurements to the upper layers. The logical channels are divided into control channels and traffic channels. Thus, the functionality handles issues like:

- mapping of the different logical channels to the appropriate transport channels and selection of appropriate transport format for the transport channels based on the instantaneous source bit rate, and optimization of the HS-DSCH transport channel;
- multiplexing/demultiplexing of the PDUs to/from transport blocks which are thereafter further treated by the physical layer;
- dynamic switching between common and dedicated transport channels based on information from the RRC sub-layer;
- priority issues for services to one UE according to information from higher layers and physical layer (e.g. available transmit power level) as well as priority handling between UEs by means of dynamic scheduling in order to increase spectrum efficiency;
- monitoring of traffic volume that can be used by the RRC sub-layer;
- hybrid ARQ with soft combining in case of the HS-DSCH transport channel.

Figure 12 shows the possibilities of mapping the logical dedicated traffic channel (DTCH) onto transport channels. There are possibilities to map onto common transport channels as well as dedicated transport channels. The choice of mapping could be determined on e.g. the DTCH traffic intensity..

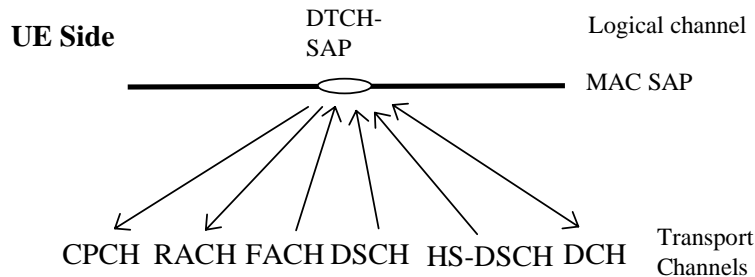

FIGURE 12

**The possible transport channel mappings of the dedicated traffic channel (DTCH)
(The arrows show the direction of the channel (UE side).
The directions are reversed from the network side)**

5.1.1.4.2 RLC sub-layer

The RLC sub-layer provides three different types of data transfer modes:

- *Transparent data transfer.* This service transmits higher layer PDUs without adding any protocol information, possibly including segmentation/reassemble functionality.
- *Unacknowledged data transfer.* This service transmits higher layer PDUs without guaranteeing delivery to the peer entity. The unacknowledged data transfer mode has the following characteristics:
 - a) detection of erroneous data: The RLC sub-layer shall deliver only those SDUs to the receiving higher layer that are free of transmission errors by using the sequence-number check function;
 - b) unique delivery: The RLC sub-layer shall deliver each SDU only once to the receiving upper layer using duplication detection function;
 - c) immediate delivery: The receiving RLC sub-layer entity shall deliver a SDU to the higher layer receiving entity as soon as it arrives at the receiver.
- *Acknowledged data transfer.* This service transmits higher layer PDUs and guarantees delivery to the peer entity. In case RLC is unable to deliver the data correctly, the user of RLC at the transmitting side is notified. For this service, both in-sequence and out-of-sequence delivery are supported. In many cases a higher layer protocol can restore the order of its PDUs. As long as the out-of-sequence properties of the lower layer are known and controlled (i.e. the higher layer protocol will not immediately request retransmission of a missing PDU) allowing out-of-sequence delivery can save memory space in the receiving RLC. The acknowledged data transfer mode has the following characteristics:
 - a) error-free delivery: error-free delivery is ensured by means of retransmission. The receiving RLC entity delivers only error-free SDUs to the higher layer;
 - b) unique delivery: the RLC sub-layer shall deliver each SDU only once to the receiving upper layer using duplication detection function;

- c) in-sequence delivery: RLC sub-layer shall provide support for in-order delivery of SDUs, i.e. RLC sub-layer should deliver SDUs to the receiving higher layer entity in the same order as the transmitting higher layer entity submits them to the RLC sub-layer;
- d) out-of-sequence delivery: alternatively to in-sequence delivery, it shall also be possible to allow that the receiving RLC entity delivers SDUs to higher layer in different order than submitted to RLC sub-layer at the transmitting side.

It also provides for RLC connection establishment/release. As well as QoS setting and notification to higher layers in case of unrecoverable errors.

An example of the data flow for non-transparent (acknowledged/unacknowledged) data transfer is shown in Fig. 5.

5.1.1.4.3 PDCP sub-layer

PDCP provides transmission and reception of Network PDUs in acknowledged, unacknowledged and transparent RLC mode.

It is responsible for the mapping of Network PDUs from one network protocol to one RLC entity and it provides compression in the transmitting entity and decompression in the receiving entity of redundant Network PDU control information (header compression/ decompression).

5.1.1.4.4 BMC sub-layer

The BMC provides a broadcast/multicast transmission service in the user plane on the radio interface for common user data in transparent or unacknowledged mode.

It can handle functionalities such as storage, scheduling and transmission of BMC messages.

5.1.1.5 Layer 3 (RRC sub-layer)

The RRC sub-layer handles the control plane signalling of Layer 3 between the UEs and the radio interface. In addition to the relation with the upper layers (such as CN) the following main functions are performed:

- *Broadcast of information provided by the non-access stratum (CN)* – The RRC layer performs system information broadcasting from the network to all UEs. The system information is normally repeated on a regular basis. This function supports broadcast of higher layer (above RRC) information. This information may be cell specific or not. As an example RRC may broadcast CN location service area information related to some specific cells.
- *Broadcast of information related to the access stratum* – The RRC layer performs system information broadcasting from the network to all UEs. This function supports broadcast of typically cell-specific information.
- *Establishment, maintenance and release of an RRC connection between the UE and the radio access network* – The establishment of an RRC connection is initiated by a request from higher layers at the UE side to establish the first signalling connection for the UE. The establishment of an RRC connection includes an optional cell re-selection, an admission control, and a Layer 2 signalling link establishment.

- *Establishment, reconfiguration and release of radio access bearers* – The RRC layer will, on request from higher layers, perform the establishment, reconfiguration and release of radio access bearers in the user plane. A number of radio access bearers can be established to an UE at the same time. At establishment and reconfiguration, the RRC layer performs admission control and selects parameters describing the radio access bearer processing in Layer 2 and Layer 1, based on information from higher layers.
- *Assignment, reconfiguration and release of radio resources for the RRC connection* – The RRC layer handles the assignment of radio resources (e.g. codes) needed for the RRC connection including needs from both the control and user plane. The RRC layer may reconfigure radio resources during an established RRC connection. This function includes coordination of the radio resource allocation between multiple radio bearers related to the same RRC connection. RRC controls the radio resources in the uplink and downlink such that UE and the radio access network can communicate using unbalanced radio resources (asymmetric uplink and downlink). RRC signals to the UE to indicate resource allocations for purposes of handover to GSM or other radio systems.
- *RRC connection mobility functions* – The RRC layer performs evaluation, decision and execution related to RRC connection mobility during an established RRC connection, such as handover, preparation of handover to GSM or other systems, cell re-selection and cell/paging area update procedures, based on e.g. measurements done by the UE.
- *Paging/notification* – The RRC layer can broadcast paging information from the network to selected UEs. The RRC layer can also initiate paging during an established RRC connection.
- *Control of requested QoS* – This function ensures that the QoS requested for the radio access bearers can be met. This includes the allocation of a sufficient number of radio resources.
- *UE measurement reporting and control of the reporting* – The measurements performed by the UE are controlled by the RRC layer, in terms of what to measure, when to measure and how to report, including both this radio interface and other systems. The RRC layer also performs the reporting of the measurements from the UE to the network.
- *Outer loop power control* – The RRC layer controls setting of the target of the closed-loop power control.
- *Control of ciphering* – The RRC layer provides procedures for setting of ciphering (on/off) between the UE and the radio access network.
- *Initial cell selection and re-selection in idle mode* – Selection of the most suitable cell based on idle mode measurements and cell selection criteria.
- *Arbitration of the radio resource allocation between the cells* – This function shall ensure optimal performance of the overall radio access network capacity.

5.1.1.6 Summary of major technical parameters

Parameter	Value	Reference to § 5.1.2
Multiple access technique and duplexing scheme	Multiple access: DS-CDMA Duplexing: FDD	5.1.2.1.1
Chip rate (Mchip/s)	3.84	5.1.2.1.4
Frame length and structure	Frame length: 10 ms Slot length: 10/15 ms. TTI: 10 ms, 20 ms, 40 ms, 80 ms, 2 ms (HS-DSCH only)	5.1.2.1.2
Occupied bandwidth	Less than 5 MHz	5.1.2.4.1, 5.1.2.4.3
Adjacent channel leakage power ratio (ACLR) (transmitter side)	UE (UE power class: +21 dBm and +24 dBm): ACLR (5 MHz) = 33 dB ACLR (10 MHz) = 43 dB BS: ACLR (5 MHz) = 45 dB ACLR (10 MHz) = 50 dB	5.1.2.4.1 5.1.2.4.3
Adjacent channel selectivity (ACS) (receiver side)	UE: ACS (5 MHz) = 33 dB BS: ACS (5 MHz) = 45 dB	5.1.2.4.1 5.1.2.4.3
Random access mechanism	Acquisition indication based random-access mechanism with power ramping on preamble followed by message	5.1.2.1.2 5.1.2.1.5
Pilot structure	Uplink: dedicated pilots Downlink: common and/or dedicated pilots	5.1.2.1.2
Inter-base station asynchronous/synchronous operation	Asynchronous; synchronous	5.1.2.1.5 5.1.2.4.3

5.1.2 Detailed specification of the radio interface

The standards contained in this section are derived from the global core specifications for IMT-2000 contained at [ties.itu.int/u/itu-r/ede/rsg8/wp8f/rtech/GCSupdat/5-1-2/](http://www.itu.int/u/itu-r/ede/rsg8/wp8f/rtech/GCSupdat/5-1-2/).

5.1.2.1 25.200 series

5.1.2.1.1 25.201 Physical layer – General description

This specification gives general description of the physical layer of the UTRA radio interface.

Release 99	Document No.	Version	Status	Issued date	Location ⁽¹⁾
⁽²⁾	ARIB/ TTC				
	CWTS				
	ETSI				
	T1				
	TTA				
Release 4	Document No.	Version	Status	Issued date	Location ⁽¹⁾
⁽²⁾	ARIB/ TTC				
	CWTS				
	ETSI				
	T1				
	TTA				
Release 5	Document No.	Version	Status	Issued date	Location ⁽¹⁾
⁽²⁾	ARIB/ TTC				
	CWTS				
	ETSI				
	T1				
	TTA				

⁽¹⁾ The relevant SDOs should make their reference material available from their Web site.

⁽²⁾ This information was supplied by the recognized external organizations and relates to their own deliverables of the transposed global core specification.

5.1.2.1.2 25.211 Physical channels and mapping of transport channels onto physical channels (FDD)

This specification describes the characteristics of the Layer 1 transport channels and physical channels in the FDD mode of UTRA. The main objectives of the specification are to be a part of the full description of the UTRA Layer 1, and to serve as a basis for the drafting of the actual technical specification (TS).

Release 99		Document No.	Version	Status	Issued date	Location ⁽¹⁾
⁽²⁾	ARIB/ TTC					
	CWTS					
	ETSI					
	T1					
	TTA					
Release 4		Document No.	Version	Status	Issued date	Location ⁽¹⁾
⁽²⁾	ARIB/ TTC					
	CWTS					
	ETSI					
	T1					
	TTA					
Release 5		Document No.	Version	Status	Issued date	Location ⁽¹⁾
⁽²⁾	ARIB/ TTC					
	CWTS					
	ETSI					
	T1					
	TTA					

^{(1), (2)} See Notes ⁽¹⁾ and ⁽²⁾, § 5.1.2.1.1.

5.1.2.1.3 25.212 Multiplexing and channel coding (FDD)

This specification describes the characteristics of the Layer 1 multiplexing and channel coding in the FDD mode of UTRA.

Release 99		Document No.	Version	Status	Issued date	Location ⁽¹⁾
(2)	ARIB/ TTC					
	CWTS					
	ETSI					
	T1					
	TTA					
Release 4		Document No.	Version	Status	Issued date	Location ⁽¹⁾
(2)	ARIB/ TTC					
	CWTS					
	ETSI					
	T1					
	TTA					
Release 5		Document No.	Version	Status	Issued date	Location ⁽¹⁾
(2)	ARIB/ TTC					
	CWTS					
	ETSI					
	T1					
	TTA					

(1), (2) See Notes ⁽¹⁾ and ⁽²⁾, § 5.1.2.1.1.

5.1.2.1.4 25.213 Spreading and modulation (FDD)

This specification describes spreading and modulation for UTRA physical layer FDD mode.

Release 99	Document No.	Version	Status	Issued date	Location ⁽¹⁾
⁽²⁾	ARIB/ TTC				
	CWTS				
	ETSI				
	T1				
	TTA				
Release 4	Document No.	Version	Status	Issued date	Location ⁽¹⁾
⁽²⁾	ARIB/ TTC				
	CWTS				
	ETSI				
	T1				
	TTA				
Release 5	Document No.	Version	Status	Issued date	Location ⁽¹⁾
⁽²⁾	ARIB/ TTC				
	CWTS				
	ETSI				
	T1				
	TTA				

^{(1), (2)} See Notes ⁽¹⁾ and ⁽²⁾, § 5.1.2.1.1.

5.1.2.1.5 25.214 Physical layer procedures (FDD)

This specification describes and establishes the characteristics of the physical layer procedures in the FDD mode of UTRA.

Release 99	Document No.	Version	Status	Issued date	Location ⁽¹⁾
⁽²⁾	ARIB/ TTC				
	CWTS				
	ETSI				
	T1				
	TTA				
Release 4	Document No.	Version	Status	Issued date	Location ⁽¹⁾
⁽²⁾	ARIB/ TTC				
	CWTS				
	ETSI				
	T1				
	TTA				
Release 5	Document No.	Version	Status	Issued date	Location ⁽¹⁾
⁽²⁾	ARIB/ TTC				
	CWTS				
	ETSI				
	T1				
	TTA				

(1), (2) See Notes ⁽¹⁾ and ⁽²⁾, § 5.1.2.1.1.

5.1.2.1.6 25.215 Physical layer – Measurements (FDD)

This specification describes the measurements done at the UE and network in order to support operation in idle mode and connected mode for FDD mode.

Release 99		Document No.	Version	Status	Issued date	Location ⁽¹⁾
(2)	ARIB/ TTC					
	CWTS					
	ETSI					
	T1					
	TTA					
Release 4		Document No.	Version	Status	Issued date	Location ⁽¹⁾
(2)	ARIB/ TTC					
	CWTS					
	ETSI					
	T1					
	TTA					
Release 5		Document No.	Version	Status	Issued date	Location ⁽¹⁾
(2)	ARIB/ TTC					
	CWTS					
	ETSI					
	T1					
	TTA					

(1), (2) See Notes ⁽¹⁾ and ⁽²⁾, § 5.1.2.1.1.

5.1.2.2 25.300 series

5.1.2.2.1 25.301 Radio interface protocol architecture

This specification describes an overview and overall description of the UE-UTRAN radio interface protocol architecture. Details of the radio protocols will be specified in companion documents.

Release 99	Document No.	Version	Status	Issued date	Location ⁽¹⁾
(2)	ARIB/ TTC				
	CWTS				
	ETSI				
	T1				
	TTA				
Release 4	Document No.	Version	Status	Issued date	Location ⁽¹⁾
(2)	ARIB/ TTC				
	CWTS				
	ETSI				
	T1				
	TTA				
Release 5	Document No.	Version	Status	Issued date	Location ⁽¹⁾
(2)	ARIB/ TTC				
	CWTS				
	ETSI				
	T1				
	TTA				

(1), (2) See Notes ⁽¹⁾ and ⁽²⁾, § 5.1.2.1.1.

5.1.2.2.2 25.302 Services provided by the physical layer

This specification describes a technical specification of the services provided by the physical layer of UTRA to upper layers.

Release 99	Document No.	Version	Status	Issued date	Location ⁽¹⁾
⁽²⁾	ARIB/ TTC				
	CWTS				
	ETSI				
	T1				
	TTA				
Release 4	Document No.	Version	Status	Issued date	Location ⁽¹⁾
⁽²⁾	ARIB/ TTC				
	CWTS				
	ETSI				
	T1				
	TTA				
Release 5	Document No.	Version	Status	Issued date	Location ⁽¹⁾
⁽²⁾	ARIB/ TTC				
	CWTS				
	ETSI				
	T1				
	TTA				

^{(1), (2)} See Notes ⁽¹⁾ and ⁽²⁾, § 5.1.2.1.1.

5.1.2.2.3 25.303 Interlayer procedures in connected mode

This specification describes informative interlayer procedures to perform the required tasks.

This specification attempts to provide a comprehensive overview of the different states and transitions within the connected mode of universal mobile telecommunications system (UMTS) terminal.

Release 99	Document No.	Version	Status	Issued date	Location ⁽¹⁾
⁽²⁾	ARIB/ TTC				
	CWTS				
	ETSI				
	T1				
	TTA				
Release 4	Document No.	Version	Status	Issued date	Location ⁽¹⁾
⁽²⁾	ARIB/ TTC				
	CWTS				
	ETSI				
	T1				
	TTA				
Release 5	Document No.	Version	Status	Issued date	Location ⁽¹⁾
⁽²⁾	ARIB/ TTC				
	CWTS				
	ETSI				
	T1				
	TTA				

^{(1), (2)} See Notes ⁽¹⁾ and ⁽²⁾, § 5.1.2.1.1.

5.1.2.2.4 25.304 UE procedures in idle mode and procedures for cell reselection in connected mode

This specification describes the overall idle mode process for the UE and the functional division between the non-access stratum and access stratum in the UE. The UE is in idle mode when the connection of the UE is closed on all layers, e.g. there is neither an MM connection nor an RRC connection.

This specification presents also examples of inter-layer procedures related to the idle mode processes and describes idle mode functionality of a dual mode UMTS/GSM UE.

Release 99	Document No.	Version	Status	Issued date	Location ⁽¹⁾
⁽²⁾	ARIB/ TTC				
	CWTS				
	ETSI				
	T1				
	TTA				
Release 4	Document No.	Version	Status	Issued date	Location ⁽¹⁾
⁽²⁾	ARIB/ TTC				
	CWTS				
	ETSI				
	T1				
	TTA				
Release 5	Document No.	Version	Status	Issued date	Location ⁽¹⁾
⁽²⁾	ARIB/ TTC				
	CWTS				
	ETSI				
	T1				
	TTA				

^{(1), (2)} See Notes ⁽¹⁾ and ⁽²⁾, § 5.1.2.1.1.

5.1.2.2.5 25.305 Stage 2 Functional Specification of UE positioning in UTRAN (LCS)

This document specifies the stage 2 of the UE Positioning function of UTRAN, which provides the mechanisms to support the calculation of the geographical position of a UE.

Release 99	Document No.	Version	Status	Issued date	Location ⁽¹⁾
(2)	ARIB/ TTC				
	CWTS				
	ETSI				
	T1				
	TTA				
Release 4	Document No.	Version	Status	Issued date	Location ⁽¹⁾
(2)	ARIB/ TTC				
	CWTS				
	ETSI				
	T1				
	TTA				
Release 5	Document No.	Version	Status	Issued date	Location ⁽¹⁾
(2)	ARIB/ TTC				
	CWTS				
	ETSI				
	T1				
	TTA				

(1), (2) See Notes ⁽¹⁾ and ⁽²⁾, § 5.1.2.1.1.

5.1.2.2.6 25.306 UE Radio Access capabilities definition

This document identifies the parameters of the access stratum part of the UE radio access capabilities. Furthermore, some reference configurations of these values are defined. The intention is that these configurations will be used for test specifications.

Release 99	Document No.	Version	Status	Issued date	Location ⁽¹⁾
(2)	ARIB/ TTC				
	CWTS				
	ETSI				
	T1				
	TTA				
Release 4	Document No.	Version	Status	Issued date	Location ⁽¹⁾
(2)	ARIB/ TTC				
	CWTS				
	ETSI				
	T1				
	TTA				
Release 5	Document No.	Version	Status	Issued date	Location ⁽¹⁾
(2)	ARIB/ TTC				
	CWTS				
	ETSI				
	T1				
	TTA				

(1), (2) See Notes (1) and (2), § 5.1.2.1.1.

5.1.2.2.7 25.307 Requirements on UE supporting a release-independent frequency band

This document specifies requirements on UEs supporting a frequency band that is independent of release.

Release 99	Document No.	Version	Status	Issued date	Location ⁽¹⁾
(2)	ARIB/ TTC				
	CWTS				
	ETSI				
	T1				
	TTA				
Release 4	Document No.	Version	Status	Issued date	Location ⁽¹⁾
(2)	ARIB/ TTC				
	CWTS				
	ETSI				
	T1				
	TTA				
Release 5	Document No.	Version	Status	Issued date	Location ⁽¹⁾
(2)	ARIB/ TTC				
	CWTS				
	ETSI				
	T1				
	TTA				

(1), (2) See Notes (1) and (2), § 5.1.2.1.1.

5.1.2.2.8 25.308 UTRA High Speed Downlink Packet Access – Overall Description (Stage 2)

This document is a technical specification of the overall support of High Speed Downlink Packet Access in UTRA.

Release 5	Document No.	Version	Status	Issued date	Location ⁽¹⁾
⁽²⁾	ARIB/ TTC				
	CWTS				
	ETSI				
	T1				
	TTA				

⁽¹⁾, ⁽²⁾ See Notes ⁽¹⁾ and ⁽²⁾, § 5.1.2.1.1.

5.1.2.2.9 25.321 Medium access control (MAC) protocol specification

This specification describes the MAC protocol.

Release 99		Doc. Number	Version	Status	Issued Date	Location⁽¹⁾
⁽²⁾	ARIB/TTC					
	ETSI					
	T1					
	TTA					
	CWTS					
Release 4		Doc. Number	Version	Status	Issued Date	Location⁽¹⁾
⁽²⁾	ARIB/TTC					
	ETSI					
	T1					
	TTA					
	CWTS					
Release 5		Doc. Number	Version	Status	Issued Date	Location⁽¹⁾
⁽²⁾	ARIB/TTC					
	ETSI					
	T1					
	TTA					
	CWTS					

^{(1), (2)} See Notes ⁽¹⁾ and ⁽²⁾, § 5.1.2.1.1.

5.1.2.2.10 25.322 Radio link control (RLC) protocol specification

This specification describes the RLC protocol.

Release 99		Doc. Number	Version	Status	Issued Date	Location⁽¹⁾
⁽²⁾	ARIB/TTC					
	ETSI					
	T1					
	TTA					
	CWTS					
Release 4		Doc. Number	Version	Status	Issued Date	Location⁽¹⁾
⁽²⁾	ARIB/TTC					
	ETSI					
	T1					
	TTA					
	CWTS					
Release 5		Doc. Number	Version	Status	Issued Date	Location⁽¹⁾
⁽²⁾	ARIB/TTC					
	ETSI					
	T1					
	TTA					
	CWTS					

(1), (2) See Notes ⁽¹⁾ and ⁽²⁾, § 5.1.2.1.1.

5.1.2.2.11 25.323 Packet Data Convergence Protocol (PDCP) protocol

This document provides the description of the Packet Data Convergence Protocol (PDCP). PDCP provides its services to the NAS at the UE or the relay at the Radio Network Controller (RNC). PDCP uses the services provided by the Radio Link Control (RLC) sublayer.

Release 99	Document No.	Version	Status	Issued date	Location ⁽¹⁾
(2)	ARIB/ TTC				
	CWTS				
	ETSI				
	T1				
	TTA				
Release 4	Document No.	Version	Status	Issued date	Location ⁽¹⁾
(2)	ARIB/ TTC				
	CWTS				
	ETSI				
	T1				
	TTA				
Release 5	Document No.	Version	Status	Issued date	Location ⁽¹⁾
(2)	ARIB/ TTC				
	CWTS				
	ETSI				
	T1				
	TTA				

(1), (2) See Notes ⁽¹⁾ and ⁽²⁾, § 5.1.2.1.1.

5.1.2.2.12 25.324 Broadcast/Multicast Control (BMC) Services

This document provides the description of the Broadcast/Multicast Control Protocol (BMC). This protocol adapts broadcast and multicast services on the radio interface.

Release 99	Document No.	Version	Status	Issued date	Location ⁽¹⁾
(2)	ARIB/ TTC				
	CWTS				
	ETSI				
	T1				
	TTA				
Release 4	Document No.	Version	Status	Issued date	Location ⁽¹⁾
(2)	ARIB/ TTC				
	CWTS				
	ETSI				
	T1				
	TTA				
Release 5	Document No.	Version	Status	Issued date	Location ⁽¹⁾
(2)	ARIB/ TTC				
	CWTS				
	ETSI				
	T1				
	TTA				

(1), (2) See Notes ⁽¹⁾ and ⁽²⁾, § 5.1.2.1.1.

5.1.2.2.13 25.331 Radio resource control (RRC) protocol specification

This specification describes the RRC protocol for the radio system. The scope of this specification contains also the information to be transported in a transparent container between source RNC and target RNC in connection to SRNC relocation.

Release 99		Doc. Number	Version	Status	Issued Date	Location⁽¹⁾
⁽²⁾	ARIB/TTC					
	ETSI					
	T1					
	TTA					
	CWTS					
Release 4		Doc. Number	Version	Status	Issued Date	Location⁽¹⁾
⁽²⁾	ARIB/TTC					
	ETSI					
	T1					
	TTA					
	CWTS					
Release 5		Doc. Number	Version	Status	Issued Date	Location⁽¹⁾
⁽²⁾	ARIB/TTC					
	ETSI					
	T1					
	TTA					
	CWTS					

(1), (2) See Notes ⁽¹⁾ and ⁽²⁾, § 5.1.2.1.1.

5.1.2.3 25.400 series

5.1.2.3.1 25.401 UTRAN overall description

This specification describes the overall architecture of the UTRAN, including internal interfaces and assumptions on the radio and Iu interfaces.

Release 99	Document No.	Version	Status	Issued date	Location ⁽¹⁾
(2)	ARIB/ TTC				
	CWTS				
	ETSI				
	T1				
	TTA				
Release 4	Document No.	Version	Status	Issued date	Location ⁽¹⁾
(2)	ARIB/ TTC				
	CWTS				
	ETSI				
	T1				
	TTA				
Release 5	Document No.	Version	Status	Issued date	Location ⁽¹⁾
(2)	ARIB/ TTC				
	CWTS				
	ETSI				
	T1				
	TTA				

(1), (2) See Notes ⁽¹⁾ and ⁽²⁾, § 5.1.2.1.1.

5.1.2.3.2 25.402 Synchronization in UTRAN Stage 2

This document constitutes the stage 2 specification of different synchronisation mechanisms in UTRAN and on Uu.

Release 99	Document No.	Version	Status	Issued date	Location ⁽¹⁾
(2)	ARIB/ TTC				
	CWTS				
	ETSI				
	T1				
	TTA				
Release 4	Document No.	Version	Status	Issued date	Location ⁽¹⁾
(2)	ARIB/ TTC				
	CWTS				
	ETSI				
	T1				
	TTA				
Release 5	Document No.	Version	Status	Issued date	Location ⁽¹⁾
(2)	ARIB/ TTC				
	CWTS				
	ETSI				
	T1				
	TTA				

(1), (2) See Notes ⁽¹⁾ and ⁽²⁾, § 5.1.2.1.1.

5.1.2.3.3 25.410 UTRAN Iu interface: general aspects and principles

This specification describes an introduction to the 25.41x series of technical specifications that define the Iu interface for the interconnection of RNC component of the UTRAN to the CN.

Release 99		Document No.	Version	Status	Issued date	Location ⁽¹⁾
(2)	ARIB/ TTC					
	CWTS					
	ETSI					
	T1					
	TTA					
Release 4		Document No.	Version	Status	Issued date	Location ⁽¹⁾
(2)	ARIB/ TTC					
	CWTS					
	ETSI					
	T1					
	TTA					
Release 5		Document No.	Version	Status	Issued date	Location ⁽¹⁾
(2)	ARIB/ TTC					
	CWTS					
	ETSI					
	T1					
	TTA					

(1), (2) See Notes ⁽¹⁾ and ⁽²⁾, § 5.1.2.1.1.

5.1.2.3.4 25.411 UTRAN Iu interface Layer 1

This specification describes the standards allowed to implement Layer 1 on the Iu interface.

The specification of transmission delay requirements and O&M requirements are not in the scope of this specification.

Release 99	Document No.	Version	Status	Issued date	Location ⁽¹⁾
(2)	ARIB/ TTC				
	CWTS				
	ETSI				
	T1				
	TTA				
Release 4	Document No.	Version	Status	Issued date	Location ⁽¹⁾
(2)	ARIB/ TTC				
	CWTS				
	ETSI				
	T1				
	TTA				
Release 5	Document No.	Version	Status	Issued date	Location ⁽¹⁾
(2)	ARIB/ TTC				
	CWTS				
	ETSI				
	T1				
	TTA				

(1), (2) See Notes ⁽¹⁾ and ⁽²⁾, § 5.1.2.1.1.

5.1.2.3.5 25.412 UTRAN Iu interface signalling transport

This specification describes the standards for user data transport protocols and related signalling protocols to establish user plane transport bearers.

Release 99	Document No.	Version	Status	Issued date	Location ⁽¹⁾
(2)	ARIB/ TTC				
	CWTS				
	ETSI				
	T1				
	TTA				
Release 4	Document No.	Version	Status	Issued date	Location ⁽¹⁾
(2)	ARIB/ TTC				
	CWTS				
	ETSI				
	T1				
	TTA				
Release 5	Document No.	Version	Status	Issued date	Location ⁽¹⁾
(2)	ARIB/ TTC				
	CWTS				
	ETSI				
	T1				
	TTA				

(1), (2) See Notes ⁽¹⁾ and ⁽²⁾, § 5.1.2.1.1.

5.1.2.3.6 25.413 UTRAN Iu interface RANAP signalling

This specification describes the signalling between the CN and the UTRAN over the Iu interface.

Release 99	Document No.	Version	Status	Issued date	Location ⁽¹⁾
(2)	ARIB/ TTC				
	CWTS				
	ETSI				
	T1				
	TTA				
Release 4	Document No.	Version	Status	Issued date	Location ⁽¹⁾
(2)	ARIB/ TTC				
	CWTS				
	ETSI				
	T1				
	TTA				
Release 5	Document No.	Version	Status	Issued date	Location ⁽¹⁾
(2)	ARIB/ TTC				
	CWTS				
	ETSI				
	T1				
	TTA				

(1), (2) See Notes ⁽¹⁾ and ⁽²⁾, § 5.1.2.1.1.

5.1.2.3.7 25.414 UTRAN Iu interface data transport and transport signalling

This specification describes the standards for user data transport protocols and related signalling protocols to establish user plane transport bearers.

Release 99	Document No.	Version	Status	Issued date	Location ⁽¹⁾
(2)	ARIB/ TTC				
	CWTS				
	ETSI				
	T1				
	TTA				
Release 4	Document No.	Version	Status	Issued date	Location ⁽¹⁾
(2)	ARIB/ TTC				
	CWTS				
	ETSI				
	T1				
	TTA				
Release 5	Document No.	Version	Status	Issued date	Location ⁽¹⁾
(2)	ARIB/ TTC				
	CWTS				
	ETSI				
	T1				
	TTA				

(1), (2) See Notes ⁽¹⁾ and ⁽²⁾, § 5.1.2.1.1.

5.1.2.3.8 25.415 UTRAN Iu interface user plane protocols

This specification describes the protocols being used to transport and control over the Iu interface, the Iu user data streams.

Release 99	Document No.	Version	Status	Issued date	Location ⁽¹⁾
(2)	ARIB/ TTC				
	CWTS				
	ETSI				
	T1				
	TTA				
Release 4	Document No.	Version	Status	Issued date	Location ⁽¹⁾
(2)	ARIB/ TTC				
	CWTS				
	ETSI				
	T1				
	TTA				
Release 5	Document No.	Version	Status	Issued date	Location ⁽¹⁾
(2)	ARIB/ TTC				
	CWTS				
	ETSI				
	T1				
	TTA				

(1), (2) See Notes ⁽¹⁾ and ⁽²⁾, § 5.1.2.1.1.

5.1.2.3.9 25.419 UTRAN Iu interface: Cell broadcast protocols between SMS-CBC and RNC

This document specifies the Service Area Broadcast Protocol (SABP) between the Cell Broadcast Centre (CBC) and the Radio Network Controller (RNC).

Release 99	Document No.	Version	Status	Issued date	Location ⁽¹⁾
(2)	ARIB/ TTC				
	CWTS				
	ETSI				
	T1				
	TTA				
Release 4	Document No.	Version	Status	Issued date	Location ⁽¹⁾
(2)	ARIB/ TTC				
	CWTS				
	ETSI				
	T1				
	TTA				
Release 5	Document No.	Version	Status	Issued date	Location ⁽¹⁾
(2)	ARIB/ TTC				
	CWTS				
	ETSI				
	T1				
	TTA				

(1), (2) See Notes (1) and (2), § 5.1.2.1.1.

5.1.2.3.10 25.420 UTRAN Iur interface: general aspects and principles

This specification describes an introduction to the TSG RAN TS 25.42x series of technical specifications that define the Iur interface. It is a logical interface for the interconnection of two RNC components of the UTRAN.

Release 99		Document No.	Version	Status	Issued date	Location ⁽¹⁾
(2)	ARIB/ TTC					
	CWTS					
	ETSI					
	T1					
	TTA					
Release 4		Document No.	Version	Status	Issued date	Location ⁽¹⁾
(2)	ARIB/ TTC					
	CWTS					
	ETSI					
	T1					
	TTA					
Release 5		Document No.	Version	Status	Issued date	Location ⁽¹⁾
(2)	ARIB/ TTC					
	CWTS					
	ETSI					
	T1					
	TTA					

(1), (2) See Notes ⁽¹⁾ and ⁽²⁾, § 5.1.2.1.1.

5.1.2.3.11 25.421 UTRAN Iur interface Layer 1

This specification describes the standards allowed to implement Layer 1 on the Iur interface.

The specification of transmission delay requirements and O&M requirements are not in the scope of this specification.

Release 99		Document No.	Version	Status	Issued date	Location ⁽¹⁾
(2)	ARIB/ TTC					
	CWTS					
	ETSI					
	T1					
	TTA					
Release 4		Document No.	Version	Status	Issued date	Location ⁽¹⁾
(2)	ARIB/ TTC					
	CWTS					
	ETSI					
	T1					
	TTA					
Release 5		Document No.	Version	Status	Issued date	Location ⁽¹⁾
(2)	ARIB/ TTC					
	CWTS					
	ETSI					
	T1					
	TTA					

(1), (2) See Notes ⁽¹⁾ and ⁽²⁾, § 5.1.2.1.1.

5.1.2.3.12 25.422 UTRAN Iur interface signalling transport

This specification describes the standards for user data transport protocols and related signalling protocols to establish user plane transport bearers.

Release 99	Document No.	Version	Status	Issued date	Location ⁽¹⁾
⁽²⁾	ARIB/ TTC				
	CWTS				
	ETSI				
	T1				
	TTA				
Release 4	Document No.	Version	Status	Issued date	Location ⁽¹⁾
⁽²⁾	ARIB/ TTC				
	CWTS				
	ETSI				
	T1				
	TTA				
Release 5	Document No.	Version	Status	Issued date	Location ⁽¹⁾
⁽²⁾	ARIB/ TTC				
	CWTS				
	ETSI				
	T1				
	TTA				

^{(1), (2)} See Notes ⁽¹⁾ and ⁽²⁾, § 5.1.2.1.1.

5.1.2.3.13 25.423 UTRAN Iur interface RNSAP signalling

This specification describes the radio network layer signalling procedures between RNCs in UTRAN.

Release 99	Document No.	Version	Status	Issued date	Location ⁽¹⁾
(2)	ARIB/ TTC				
	CWTS				
	ETSI				
	T1				
	TTA				
Release 4	Document No.	Version	Status	Issued date	Location ⁽¹⁾
(2)	ARIB/ TTC				
	CWTS				
	ETSI				
	T1				
	TTA				
Release 5	Document No.	Version	Status	Issued date	Location ⁽¹⁾
(2)	ARIB/ TTC				
	CWTS				
	ETSI				
	T1				
	TTA				

(1), (2) See Notes ⁽¹⁾ and ⁽²⁾, § 5.1.2.1.1.

5.1.2.3.14 25.424 UTRAN Iur interface data transport and transport signalling for common transport channel data streams

This specification describes the UTRAN RNS-RNS (Iur) interface data transport and transport signalling for common transport channel data streams.

Release 99	Document No.	Version	Status	Issued date	Location ⁽¹⁾
(2)	ARIB/ TTC				
	CWTS				
	ETSI				
	T1				
	TTA				
Release 4	Document No.	Version	Status	Issued date	Location ⁽¹⁾
(2)	ARIB/ TTC				
	CWTS				
	ETSI				
	T1				
	TTA				
Release 5	Document No.	Version	Status	Issued date	Location ⁽¹⁾
(2)	ARIB/ TTC				
	CWTS				
	ETSI				
	T1				
	TTA				

(1), (2) See Notes ⁽¹⁾ and ⁽²⁾, § 5.1.2.1.1.

5.1.2.3.15 25.425 UTRAN Iur interface user plane protocols for common transport channel data streams

This specification describes the UTRAN RNS-RNS (Iur) interface user plane protocols for common transport channel data streams.

Release 99		Document No.	Version	Status	Issued date	Location ⁽¹⁾
(2)	ARIB/ TTC					
	CWTS					
	ETSI					
	T1					
	TTA					
Release 4		Document No.	Version	Status	Issued date	Location ⁽¹⁾
(2)	ARIB/ TTC					
	CWTS					
	ETSI					
	T1					
	TTA					
Release 5		Document No.	Version	Status	Issued date	Location ⁽¹⁾
(2)	ARIB/ TTC					
	CWTS					
	ETSI					
	T1					
	TTA					

(1), (2) See Notes ⁽¹⁾ and ⁽²⁾, § 5.1.2.1.1.

5.1.2.3.16 25.426 UTRAN Iur and Iub interface data transport and transport signalling for DCH data streams

This specification describes the transport bearers for the DCH data streams on UTRAN Iur and Iub interfaces. The corresponding transport network control plane is also specified. The physical layer for the transport bearers is outside the scope of this TS.

Release 99	Document No.	Version	Status	Issued date	Location ⁽¹⁾
(2)	ARIB/ TTC				
	CWTS				
	ETSI				
	T1				
	TTA				
Release 4	Document No.	Version	Status	Issued date	Location ⁽¹⁾
(2)	ARIB/ TTC				
	CWTS				
	ETSI				
	T1				
	TTA				
Release 5	Document No.	Version	Status	Issued date	Location ⁽¹⁾
(2)	ARIB/ TTC				
	CWTS				
	ETSI				
	T1				
	TTA				

(1), (2) See Notes ⁽¹⁾ and ⁽²⁾, § 5.1.2.1.1.

5.1.2.3.17 25.427 UTRAN Iur and Iub interface user plane protocols for DCH data streams

This specification describes the UTRAN Iur and Iub interfaces user plane protocols for dedicated transport channel data streams.

Release 99	Document No.	Version	Status	Issued date	Location ⁽¹⁾
(2)	ARIB/ TTC				
	CWTS				
	ETSI				
	T1				
	TTA				
Release 4	Document No.	Version	Status	Issued date	Location ⁽¹⁾
(2)	ARIB/ TTC				
	CWTS				
	ETSI				
	T1				
	TTA				
Release 5	Document No.	Version	Status	Issued date	Location ⁽¹⁾
(2)	ARIB/ TTC				
	CWTS				
	ETSI				
	T1				
	TTA				

(1), (2) See Notes ⁽¹⁾ and ⁽²⁾, § 5.1.2.1.1.

5.1.2.3.18 25.430 UTRAN Iub interface: general aspects and principles

This specification describes the TSG RAN TS 25.43x series of UMTS technical specifications that define the Iub interface. The Iub interface is a logical interface for the interconnection of Node B and RNC components of the UTRAN.

Release 99	Document No.	Version	Status	Issued date	Location ⁽¹⁾
(2)	ARIB/ TTC				
	CWTS				
	ETSI				
	T1				
	TTA				
Release 4	Document No.	Version	Status	Issued date	Location ⁽¹⁾
(2)	ARIB/ TTC				
	CWTS				
	ETSI				
	T1				
	TTA				
Release 5	Document No.	Version	Status	Issued date	Location ⁽¹⁾
(2)	ARIB/ TTC				
	CWTS				
	ETSI				
	T1				
	TTA				

(1), (2) See Notes ⁽¹⁾ and ⁽²⁾, § 5.1.2.1.1.

5.1.2.3.19 25.431 UTRAN Iub interface: Layer 1

This specification describes the standards allowed to implement Layer 1 on the Iub interface.

The specification of transmission delay requirements and O&M requirements is not in the scope of this specification.

Release 99	Document No.	Version	Status	Issued date	Location ⁽¹⁾
(2)	ARIB/ TTC				
	CWTS				
	ETSI				
	T1				
	TTA				
Release 4	Document No.	Version	Status	Issued date	Location ⁽¹⁾
(2)	ARIB/ TTC				
	CWTS				
	ETSI				
	T1				
	TTA				
Release 5	Document No.	Version	Status	Issued date	Location ⁽¹⁾
(2)	ARIB/ TTC				
	CWTS				
	ETSI				
	T1				
	TTA				

(1), (2) See Notes ⁽¹⁾ and ⁽²⁾, § 5.1.2.1.1.

5.1.2.3.20 25.432 UTRAN Iub interface: signalling transport

This specification describes the signalling transport related to the Node B application part (NBAP) signalling to be used across the Iub interface. The Iub interface is a logical interface for the interconnection of Node B and RNC components of the UTRAN. The RNC signalling between these nodes is based on NBAP.

Release 99	Document No.	Version	Status	Issued date	Location ⁽¹⁾
(2)	ARIB/ TTC				
	CWTS				
	ETSI				
	T1				
	TTA				
Release 4	Document No.	Version	Status	Issued date	Location ⁽¹⁾
(2)	ARIB/ TTC				
	CWTS				
	ETSI				
	T1				
	TTA				
Release 5	Document No.	Version	Status	Issued date	Location ⁽¹⁾
(2)	ARIB/ TTC				
	CWTS				
	ETSI				
	T1				
	TTA				

(1), (2) See Notes ⁽¹⁾ and ⁽²⁾, § 5.1.2.1.1.

5.1.2.3.21 25.433 UTRAN Iub interface: NBAP signalling

This specification describes the standards for NBAP specification to be used over Iub interface.

Release 99	Document No.	Version	Status	Issued date	Location ⁽¹⁾
(2)	ARIB/ TTC				
	CWTS				
	ETSI				
	T1				
	TTA				
Release 4	Document No.	Version	Status	Issued date	Location ⁽¹⁾
(2)	ARIB/ TTC				
	CWTS				
	ETSI				
	T1				
	TTA				
Release 5	Document No.	Version	Status	Issued date	Location ⁽¹⁾
(2)	ARIB/ TTC				
	CWTS				
	ETSI				
	T1				
	TTA				

(1), (2) See Notes ⁽¹⁾ and ⁽²⁾, § 5.1.2.1.1.

5.1.2.3.22 25.434 UTRAN Iub interface data transport and transport signalling for common transport channel data streams

This specification describes the UTRAN RNC-Node B (Iub) interface data transport and transport signalling for CCH data streams.

Release 99	Document No.	Version	Status	Issued date	Location ⁽¹⁾
(2)	ARIB/ TTC				
	CWTS				
	ETSI				
	T1				
	TTA				
Release 4	Document No.	Version	Status	Issued date	Location ⁽¹⁾
(2)	ARIB/ TTC				
	CWTS				
	ETSI				
	T1				
	TTA				
Release 5	Document No.	Version	Status	Issued date	Location ⁽¹⁾
(2)	ARIB/ TTC				
	CWTS				
	ETSI				
	T1				
	TTA				

(1), (2) See Notes ⁽¹⁾ and ⁽²⁾, § 5.1.2.1.1.

5.1.2.3.23 25.435 UTRAN Iub interface user plane protocols for common transport channel data streams

This specification describes the UTRAN RNC-Node B (Iub) interface user plane protocols for common transport channel data streams.

release 99	Document No.	Version	Status	Issued date	Location ⁽¹⁾
(2)	ARIB/ TTC				
	CWTS				
	ETSI				
	T1				
	TTA				
Release 4	Document No.	Version	Status	Issued date	Location ⁽¹⁾
(2)	ARIB/ TTC				
	CWTS				
	ETSI				
	T1				
	TTA				
Release 5	Document No.	Version	Status	Issued date	Location ⁽¹⁾
(2)	ARIB/ TTC				
	CWTS				
	ETSI				
	T1				
	TTA				

(1), (2) See Notes ⁽¹⁾ and ⁽²⁾, § 5.1.2.1.1.

5.1.2.3.24 25.442 UTRAN implementation specific O&M transport

This specification describes the transport of implementation specific O&M signalling between Node B and the management platform in case that the transport is routed via the RNC.

Release 99	Document No.	Version	Status	Issued date	Location ⁽¹⁾
⁽²⁾	ARIB/ TTC				
	CWTS				
	ETSI				
	T1				
	TTA				
Release 4	Document No.	Version	Status	Issued date	Location ⁽¹⁾
⁽²⁾	ARIB/ TTC				
	CWTS				
	ETSI				
	T1				
	TTA				
Release 5	Document No.	Version	Status	Issued date	Location ⁽¹⁾
⁽²⁾	ARIB/ TTC				
	CWTS				
	ETSI				
	T1				
	TTA				

^{(1), (2)} See Notes ⁽¹⁾ and ⁽²⁾, § 5.1.2.1.1.

5.1.2.3.25 25.450 UTRAN Iupc interface general aspects and principles

The present document is an introduction to the TSG RAN TS 25.45z series of UMTS Technical Specifications that define the Iupc Interface. The Iupc interface is a logical interface for the interconnection of Standalone ~~A-GPS~~-SMLC (SAS) and Radio Network Controller (RNC) components of the Universal Terrestrial Radio Access Network (UTRAN) for the UMTS system.

Release 5	Document No.	Version	Status	Issued date	Location ⁽¹⁾
(2)	ARIB/ TTC				
	CWTS				
	ETSI				
	T1				
	TTA				

(1),(2) See Notes ⁽¹⁾ and ⁽²⁾, § 5.1.2.1.1.

5.1.2.3.26 25.451 UTRAN Iupc Interface Layer 1

The present document specifies the standards allowed to implement Layer 1 on the Iupc interface.

Release 5	Document No.	Version	Status	Issued date	Location ⁽¹⁾
(2)	ARIB/ TTC				
	CWTS				
	ETSI				
	T1				
	TTA				

(1),(2) See Notes ⁽¹⁾ and ⁽²⁾, § 5.1.2.1.1.

5.1.2.3.27 25.452 UTRAN Iupc Interface: Signalling Transport

The present document specifies the signalling transport related to PCAP signalling to be used across the Iupc interface.

Release 5	Document No.	Version	Status	Issued date	Location ⁽¹⁾
(2)	ARIB/ TTC				
	CWTS				
	ETSI				
	T1				
	TTA				

(1),(2) See Notes ⁽¹⁾ and ⁽²⁾, § 5.1.2.1.1.

5.1.2.3.28 25.453 UTRAN Iupc interface PCAP signalling

The present document specifies the *Positioning Calculation Application Part (PCAP)* between the Radio Network Controller (RNC) and the Stand-alone ~~A-GPS~~-SMLC (SAS).

Release 5	Document No.	Version	Status	Issued date	Location ⁽¹⁾
(2)	ARIB/ TTC				
	CWTS				
	ETSI				
	T1				
	TTA				

(1),(2) See Notes ⁽¹⁾ and ⁽²⁾, § 5.1.2.1.1.

5.1.2.4 25.100 series

5.1.2.4.1 25.101 UE radio transmission and reception (FDD)

This document establishes the minimum RF characteristics of the UTRA User Equipment (UE) operating in the FDD mode. The values in the TS make no allowance for measurement uncertainty in conformance testing. Test limits to be used for conformance testing are specified separately in the UE conformance test specifications TS 34.121.

Release 99	Document No.	Version	Status	Issued date	Location ⁽¹⁾
⁽²⁾	ARIB/ TTC				
	CWTS				
	ETSI				
	T1				
	TTA				
Release 4	Document No.	Version	Status	Issued date	Location ⁽¹⁾
⁽²⁾	ARIB/ TTC				
	CWTS				
	ETSI				
	T1				
	TTA				
Release 5	Document No.	Version	Status	Issued date	Location ⁽¹⁾
⁽²⁾	ARIB/ TTC				
	CWTS				
	ETSI				
	T1				
	TTA				

^{(1), (2)} See Notes ⁽¹⁾ and ⁽²⁾, § 5.1.2.1.1.

5.1.2.4.2 25.106 UTRA Repeater; Radio Transmission and Reception

The present document establishes the minimum radio frequency performance of UTRA repeaters.

Release 99		Document No.	Version	Status	Issued date	Location ⁽¹⁾
	ARIB/ TTC					
	ETSI					
	T1					
	TTA					
	CWTS					
Release 4		Document No.	Version	Status	Issued date	Location ⁽¹⁾
	CWTS					
	ETSI					
	T1					
	TTA					
Release 5		Document No.	Version	Status	Issued date	Location ⁽¹⁾
	CWTS					
	ETSI					
	T1					
	TTA					

⁽¹⁾ See Note ⁽¹⁾, § 5.1.2.1.1.

5.1.2.4.3 25.133 Requirements for support of radio resource management (FDD)

This specification describes the requirements for support of radio resource management for FDD including requirements on measurements in UTRAN and the UE as well as on node dynamic behaviour and interaction, in terms of delay and response characteristics.

Release 99	Document No.	Version	Status	Issued date	Location ⁽¹⁾
⁽²⁾	ARIB/ TTC				
	CWTS				
	T1				
	TTA				
	ETSI				
Release 4	Document No.	Version	Status	Issued date	Location ⁽¹⁾
⁽²⁾	ARIB/ TTC				
	CWTS				
	T1				
	TTA				
	ETSI				
Release 5	Document No.	Version	Status	Issued date	Location ⁽¹⁾
⁽²⁾	ARIB/ TTC				
	CWTS				
	T1				
	TTA				
	ETSI				

^{(1), (2)} See Notes ⁽¹⁾ and ⁽²⁾, § 5.1.2.1.1.

5.1.2.4.4 25.104 BTS radio transmission and reception (FDD)

This specification describes the base station minimum RF characteristics of the FDD mode of UTRA. The values in the TS make no allowance for measurements uncertainties in conformance testing. Test limit to be used for conformance testing are specified separately in the BS conformance test Specification TS 25.141.

Release 99	Document No.	Version	Status	Issued date	Location ⁽¹⁾
⁽²⁾	ARIB/ TTC				
	CWTS				
	ETSI				
	T1				
	TTA				
Release 4	Document No.	Version	Status	Issued date	Location ⁽¹⁾
⁽²⁾	ARIB/ TTC				
	CWTS				
	ETSI				
	T1				
	TTA				
Release 5	Document No.	Version	Status	Issued date	Location ⁽¹⁾
⁽²⁾	ARIB/ TTC				
	CWTS				
	ETSI				
	T1				
	TTA				

^{(1), (2)} See Notes ⁽¹⁾ and ⁽²⁾, § 5.1.2.1.1.

5.1.2.4.5 25.141 Base station conformance testing (FDD)

This specification describes the RF test methods and conformance requirements for UTRA base transceiver stations (BTS) operating in the FDD mode. These have been derived from, and are consistent with, the core UTRA specifications specified in the requirements reference subclause of each test. The maximum acceptable measurement uncertainty is specified in the TS for each test, where appropriate.

Release 99	Document No.	Version	Status	Issued date	Location ⁽¹⁾
(2)	ARIB/ TTC				
	CWTS				
	ETSI				
	T1				
	TTA				
Release 4	Document No.	Version	Status	Issued date	Location ⁽¹⁾
(2)	ARIB/ TTC				
	CWTS				
	ETSI				
	T1				
	TTA				
Release 5	Document No.	Version	Status	Issued date	Location ⁽¹⁾
(2)	ARIB/ TTC				
	CWTS				
	ETSI				
	T1				
	TTA				

(1), (2) See Notes ⁽¹⁾ and ⁽²⁾, § 5.1.2.1.1.

5.1.2.4.6 25.113 Base station EMC (see Note 1)

This specification describes the assessment of base stations and associated ancillary equipment in respect of EMC.

NOTE 1 – This specification does not include the antenna port immunity and emissions.

Release 99	Document No.	Version	Status	Issued date	Location ⁽¹⁾
(2)	ARIB/ TTC				
	CWTS				
	ETSI				
	T1				
	TTA				
Release 4	Document No.	Version	Status	Issued date	Location ⁽¹⁾
(2)	ARIB/ TTC				
	CWTS				
	ETSI				
	T1				
	TTA				
Release 5	Document No.	Version	Status	Issued date	Location ⁽¹⁾
(2)	ARIB/ TTC				
	CWTS				
	ETSI				
	T1				
	TTA				

(1), (2) See Notes ⁽¹⁾ and ⁽²⁾, § 5.1.2.1.1.

5.1.2.4.7 25.143 UTRA Repeater; Conformance Testing

The present document specifies the Radio Frequency (RF) test methods and Minimum Requirements for UTRA Repeaters. These have been derived from, and are consistent with the UTRA Repeater specifications defined in TS 25.106.

Release 4	Document No.	Version	Status	Issued date	Location ⁽¹⁾
	CWTS				
	ETSI				
	T1				
	TTA				
Release 5	Document No.	Version	Status	Issued date	Location ⁽¹⁾
	CWTS				
	ETSI				
	T1				
	TTA				

⁽¹⁾. See Note ⁽¹⁾, § 5.1.2.1.1.

5.1.2.5 34.100 Series

5.1.2.5.1 34.108 Common Test Environments for User Equipment (UE) Conformance Testing

This document contains definitions of reference conditions and test signals, default parameters, reference Radio Bearer configurations, common requirements for test equipment and generic set-up procedures for use in UE conformance tests.

Release 99	Document No.	Version	Status	Issued date	Location ⁽¹⁾
(2)	ARIB/ TTC				
	CWTS				
	ETSI				
	T1				
	TTA				
Release 4	Document No.	Version	Status	Issued date	Location ⁽¹⁾
(2)	ARIB/ TTC				
	CWTS				
	ETSI				
	T1				
	TTA				
Release 5	Document No.	Version	Status	Issued date	Location ⁽¹⁾
(2)	ARIB/ TTC				
	CWTS				
	ETSI				
	T1				
	TTA				

(1), (2) See Notes ⁽¹⁾ and ⁽²⁾, § 5.1.2.1.1.

5.1.2.5.2 34.109 Logical Test Interface (TDD and FDD)

This document specifies for User Equipment (UE), in UMTS system, for FDD and TDD modes, those UE functions that are required for conformance testing purposes.

Release 99	Document No.	Version	Status	Issued date	Location ⁽¹⁾
(2)	ARIB/ TTC				
	CWTS				
	ETSI				
	T1				
	TTA				
Release 4	Document No.	Version	Status	Issued date	Location ⁽¹⁾
(2)	ARIB/ TTC				
	CWTS				
	ETSI				
	T1				
	TTA				
Release 5	Document No.	Version	Status	Issued date	Location ⁽¹⁾
(2)	ARIB/ TTC				
	CWTS				
	ETSI				
	T1				
	TTA				

(1), (2) See Notes (1) and (2), § 5.1.2.1.1.

5.1.2.5.3 34.121 Terminal Conformance Specification, Radio Transmission and Reception (FDD)

This document specifies the Radio Frequency (RF) test methods and conformance requirements for UTRA User Equipment (UE) operating in the FDD mode. These have been derived from, and are consistent with, the core UTRA specifications. The maximum acceptable measurement uncertainty is specified in the TS for each test, where appropriate.

Release 99	Document No.	Version	Status	Issued date	Location ⁽¹⁾
(2)	ARIB/ TTC				
	CWTS				
	ETSI				
	T1				
	TTA				
Release 4	Document No.	Version	Status	Issued date	Location ⁽¹⁾
(2)	ARIB/ TTC				
	CWTS				
	ETSI				
	T1				
	TTA				
Release 5	Document No.	Version	Status	Issued date	Location ⁽¹⁾
(2)	ARIB/ TTC				
	CWTS				
	ETSI				
	T1				
	TTA				

(1), (2) See Notes (1) and (2), § 5.1.2.1.1.

5.1.2.5.4 34.123-1 UE Conformance Specification, Part 1- Conformance specification

This document specifies the protocol conformance testing for the 3rd Generation User Equipment (UE). This is the first part of a multi-part test specification.

Release 99	Document No.	Version	Status	Issued date	Location ⁽¹⁾
(2)	ARIB/ TTC				
	CWTS				
	ETSI				
	T1				
	TTA				
Release 4	Document No.	Version	Status	Issued date	Location ⁽¹⁾
(2)	ARIB/ TTC				
	CWTS				
	ETSI				
	T1				
	TTA				
Release 5	Document No.	Version	Status	Issued date	Location ⁽¹⁾
(2)	ARIB/ TTC				
	CWTS				
	ETSI				
	T1				
	TTA				

(1),(2) See Notes (1) and (2), § 5.1.2.1.1.

5.1.2.5.5 34.123-2 UE Conformance Specification, Part 2- ICS

This document provides the Implementation Conformance Statement (ICS) proforma for 3rd Generation User Equipment (UE), in compliance with the relevant requirements, and in accordance with the relevant guidance given in ISO/IEC 9646-7 and ETS 300 406. This document also specifies a recommended applicability statement for the test cases included in TS 34.123-1. These applicability statements are based on the features implemented in the UE.

Release 99	Document No.	Version	Status	Issued date	Location ⁽¹⁾
(2)	ARIB/ TTC				
	CWTS				
	ETSI				
	T1				
	TTA				
Release 4	Document No.	Version	Status	Issued date	Location ⁽¹⁾
(2)	ARIB/ TTC				
	CWTS				
	ETSI				
	T1				
	TTA				
Release 5	Document No.	Version	Status	Issued date	Location ⁽¹⁾
(2)	ARIB/ TTC				
	CWTS				
	ETSI				
	T1				
	TTA				

(1), (2) See Notes ⁽¹⁾ and ⁽²⁾, § 5.1.2.1.1.

5.1.2.5.6 34.124 Electromagnetic compatibility (EMC) requirements for Mobile terminals and ancillary equipment

This document establishes the essential EMC requirements for "3rd generation" digital cellular mobile terminal equipment and ancillary accessories in combination with a 3GPP user equipment (UE).

Release 99	Document No.	Version	Status	Issued date	Location ⁽¹⁾
(2)	ARIB/ TTC				
	CWTS				
	ETSI				
	T1				
	TTA				
Release 4	Document No.	Version	Status	Issued date	Location ⁽¹⁾
(2)	ARIB/ TTC				
	CWTS				
	ETSI				
	T1				
	TTA				
Release 5	Document No.	Version	Status	Issued date	Location ⁽¹⁾
(2)	ARIB/ TTC				
	CWTS				
	ETSI				
	T1				
	TTA				

(1),(2) See Notes ⁽¹⁾ and ⁽²⁾, § 5.1.2.1.1.

5.1.2.6 Core network aspects

5.1.2.6.1 23.108 Mobile radio interface Layer 3 specification core network protocols – Stage 2

This specification describes the procedures used at the radio interface for call control (CC), mobility management (MM) and session management (SM). It shall hold examples of the structured procedures.

Release 99	Document No.	Version	Status	Issued date	Location ⁽¹⁾
⁽²⁾	ARIB/ TTC				
	CWTS				
	ETSI				
	T1				
	TTA				
Release 4	Document No.	Version	Status	Issued date	Location ⁽¹⁾
⁽²⁾	ARIB/ TTC				
	CWTS				
	ETSI				
	T1				
	TTA				
Release 5	Document No.	Version	Status	Issued date	Location ⁽¹⁾
⁽²⁾	ARIB/ TTC				
	CWTS				
	ETSI				
	T1				
	TTA				

^{(1), (2)} See Notes ⁽¹⁾ and ⁽²⁾, § 5.1.2.1.1.

5.1.2.6.2 23.110 UMTS access stratum services and functions

This specification describes the detailed specifications of the protocols which rule the information flows, both control and user data, between the access stratum and the parts of UMTS outside the access stratum, and of the detailed specifications of the UTRAN. These detailed specifications are to be found in other technical specifications.

Release 99	Document No.	Version	Status	Issued date	Location ⁽¹⁾
⁽²⁾	ARIB/ TTC				
	CWTS				
	ETSI				
	T1				
	TTA				
Release 4	Document No.	Version	Status	Issued date	Location ⁽¹⁾
⁽²⁾	ARIB/ TTC				
	CWTS				
	ETSI				
	T1				
	TTA				
Release 5	Document No.	Version	Status	Issued date	Location ⁽¹⁾
⁽²⁾	ARIB/ TTC				
	CWTS				
	ETSI				
	T1				
	TTA				

^{(1), (2)} See Notes ⁽¹⁾ and ⁽²⁾, § 5.1.2.1.1.

5.1.2.6.3 23.122 Functions related to Mobile Stations (MS) in idle mode and group receive mode

This specification shall give an overview of the tasks undertaken by a Mobile Station (MS) when in idle mode, that is, switched on but not having a dedicated channel allocated, e.g. not making or receiving a call, or when in group receive mode, that is, receiving a group call or broadcast call but not having a dedicated connection. It also describes the corresponding network functions.

Release 99	Document No.	Version	Status	Issued date	Location ⁽¹⁾
(2)	ARIB/ TTC				
	CWTS				
	ETSI				
	T1				
	TTA				
Release 4	Document No.	Version	Status	Issued date	Location ⁽¹⁾
(2)	ARIB/ TTC				
	CWTS				
	ETSI				
	T1				
	TTA				
Release 5	Document No.	Version	Status	Issued date	Location ⁽¹⁾
(2)	ARIB/ TTC				
	CWTS				
	ETSI				
	T1				
	TTA				

(1), (2) See Notes ⁽¹⁾ and ⁽²⁾, § 5.1.2.1.1.

5.1.2.6.4 24.007 Mobile radio interface signalling Layer 3 – general aspects

This specification describes the principal architecture of Layer 3 and its sub-layers on the GSM Um interface, i.e. the interface between mobile station (MS) and network; for the CM sub-layer, the description is restricted to paradigmatic examples, CC, supplementary services, and short message services for non-general packet radio service (GPRS) services. It also defines the basic message format and error handling applied by the Layer 3 protocols.

Release 99	Document No.	Version	Status	Issued date	Location ⁽¹⁾
(2)	ARIB/ TTC				
	CWTS				
	ETSI				
	T1				
	TTA				
Release 4	Document No.	Version	Status	Issued date	Location ⁽¹⁾
(2)	ARIB/ TTC				
	CWTS				
	ETSI				
	T1				
	TTA				
Release 5	Document No.	Version	Status	Issued date	Location ⁽¹⁾
(2)	ARIB/ TTC				
	CWTS				
	ETSI				
	T1				
	TTA				

(1), (2) See Notes ⁽¹⁾ and ⁽²⁾, § 5.1.2.1.1.

5.1.2.6.5 24.008 Mobile radio interface Layer 3 specification; core network protocols – Stage 3

This specification describes the procedures used at the radio interface for CC, MM and SM.

The procedures currently described are for the CC of circuit-switched connections, SM for GPRS services, MM and radio resource management for circuit-switched and GPRS services.

Release 99		Document No.	Version	Status	Issued date	Location ⁽¹⁾
(2)	ARIB/ TTC					
	CWTS					
	ETSI					
	T1					
	TTA					
Release 4		Document No.	Version	Status	Issued date	Location ⁽¹⁾
(2)	ARIB/ TTC					
	CWTS					
	ETSI					
	T1					
	TTA					
Release 5		Document No.	Version	Status	Issued date	Location ⁽¹⁾
(2)	ARIB/ TTC					
	CWTS					
	ETSI					
	T1					
	TTA					

(1), (2) See Notes ⁽¹⁾ and ⁽²⁾, § 5.1.2.1.1.

5.1.2.6.6 24.011 Point-to-point short message service (SMS) support on mobile radio interface

This specification describes the procedures used across the mobile radio interface by the signalling Layer 3 function short message control (SMC) and short message relay (SM-RL) function for both circuit-switched GSM and GPRS.

Release 99	Document No.	Version	Status	Issued date	Location ⁽¹⁾
⁽²⁾	ARIB/ TTC				
	CWTS				
	ETSI				
	T1				
	TTA				
Release 4	Document No.	Version	Status	Issued date	Location ⁽¹⁾
⁽²⁾	ARIB/ TTC				
	CWTS				
	ETSI				
	T1				
	TTA				
Release 5	Document No.	Version	Status	Issued date	Location ⁽¹⁾
⁽²⁾	ARIB/ TTC				
	CWTS				
	ETSI				
	T1				
	TTA				

^{(1), (2)} See Notes ⁽¹⁾ and ⁽²⁾, § 5.1.2.1.1.

5.1.2.6.7 23.060 General packet radio service (GPRS) service description – Stage 2

This specification describes a general overview over the GPRS architecture as well as a more detailed overview of the MS – CN protocol architecture. Details of the protocols will be specified in companion documents.

Release 99	Document No.	Version	Status	Issued date	Location ⁽¹⁾
⁽²⁾	ARIB/ TTC				
	CWTS				
	ETSI				
	T1				
	TTA				
Release 4	Document No.	Version	Status	Issued date	Location ⁽¹⁾
⁽²⁾	ARIB/ TTC				
	CWTS				
	ETSI				
	T1				
	TTA				
Release 5	Document No.	Version	Status	Issued date	Location ⁽¹⁾
⁽²⁾	ARIB/ TTC				
	CWTS				
	ETSI				
	T1				
	TTA				

^{(1), (2)} See Notes ⁽¹⁾ and ⁽²⁾, § 5.1.2.1.1.

5.1.2.6.8 24.022 Radio link protocol (RLP) for circuit switched bearer and teleservices

This specification describes the RLP for data transmission over the UMTS public land mobile network (PLMN). RLP covers the Layer 2 functionality of the ISO OSI reference model (IS 7498). It is based on ideas contained in IS 3309, IS 4335 and IS 7809 (HDLC of ISO) as well as ITU-T Recommendations X.25, Q.921 and Q.922 (LAP-B and LAP-D, respectively). RLP has been tailored to the special needs of digital radio transmission. RLP provides to its users the OSI data link service (IS 8886).

Release 99		Document No.	Version	Status	Issued date	Location ⁽¹⁾
	ARIB/ TTC					
	CWTS					
	ETSI					
	T1					
	TTA					
Release 4		Document No.	Version	Status	Issued date	Location ⁽¹⁾
	ARIB/ TTC					
	CWTS					
	ETSI					
	T1					
	TTA					
Release 5		Document No.	Version	Status	Issued date	Location ⁽¹⁾
	ARIB/ TTC					
	CWTS					
	ETSI					
	T1					
	TTA					

⁽¹⁾ See Note ⁽¹⁾, § 5.1.2.1.1.

5.1.2.6.9 24.010 Mobile radio interface Layer 3 – supplementary services specification – general aspects

This specification describes the general aspects of the specification of supplementary services at the Layer 3 radio interface. Details will be specified in other documents.

Release 99	Document No.	Version	Status	Issued date	Location ⁽¹⁾
⁽²⁾	ARIB/ TTC				
	CWTS				
	ETSI				
	T1				
	TTA				
Release 4	Document No.	Version	Status	Issued date	Location ⁽¹⁾
⁽²⁾	ARIB/ TTC				
	CWTS				
	ETSI				
	T1				
	TTA				
Release 5	Document No.	Version	Status	Issued date	Location ⁽¹⁾
⁽²⁾	ARIB/ TTC				
	CWTS				
	ETSI				
	T1				
	TTA				

^{(1), (2)} See Notes ⁽¹⁾ and ⁽²⁾, § 5.1.2.1.1.

5.1.2.6.10 24.080 Mobile radio interface Layer 3 – supplementary services specification – formats and coding

This specification describes the coding of information necessary for support of supplementary service operation on the mobile radio interface L3. Details will be specified in other documents.

Release 99		Document No.	Version	Status	Issued date	Location ⁽¹⁾
(2)	ARIB/ TTC					
	CWTS					
	ETSI					
	T1					
	TTA					
Release 4		Document No.	Version	Status	Issued date	Location ⁽¹⁾
(2)	ARIB/ TTC					
	CWTS					
	ETSI					
	T1					
	TTA					
Release 5		Document No.	Version	Status	Issued date	Location ⁽¹⁾
(2)	ARIB/ TTC					
	CWTS					
	ETSI					
	T1					
	TTA					

(1), (2) See Notes ⁽¹⁾ and ⁽²⁾, § 5.1.2.1.1.

5.1.2.7 Terminal aspects

5.1.2.7.1 21.111 USIM and IC card requirements

This specification describes the requirements of the USIM and the USIM IC card (UICC). These are derived from the service and security requirements defined in the respective specifications. The document is the basis for the detailed specification of the USIM and the UICC, and the interface to the terminal.

Release 99		Document No.	Version	Status	Issued date	Location ⁽¹⁾
(2)	ARIB/ TTC					
	CWTS					
	ETSI					
	T1					
	TTA					
Release 4		Document No.	Version	Status	Issued date	Location ⁽¹⁾
(2)	ARIB/ TTC					
	CWTS					
	ETSI					
	T1					
	TTA					
Release 5		Document No.	Version	Status	Issued date	Location ⁽¹⁾
(2)	ARIB/ TTC					
	CWTS					
	ETSI					
	T1					
	TTA					

(1), (2) See Notes ⁽¹⁾ and ⁽²⁾, § 5.1.2.1.1.

5.1.2.7.2 31.101 UICC-Terminal Interface; Physical and Logical Characteristics

This document specifies the interface between the UICC and the Terminal for 3G telecom network operation. This includes the requirements for the physical characteristics of the UICC, the electrical interface between the UICC and the Terminal, the initial communication establishment and the transport protocols, the communication commands and the procedures and the application independent files and protocols.

Release 99	Document No.	Version	Status	Issued date	Location ⁽¹⁾
(2)	ARIB/ TTC				
	CWTS				
	ETSI				
	T1				
	TTA				
Release 4	Document No.	Version	Status	Issued date	Location ⁽¹⁾
(2)	ARIB/ TTC				
	CWTS				
	ETSI				
	T1				
	TTA				
Release 5	Document No.	Version	Status	Issued date	Location ⁽¹⁾
(2)	ARIB/ TTC				
	CWTS				
	ETSI				
	T1				
	TTA				

(1), (2) See Notes (1) and (2), § 5.1.2.1.1.

5.1.2.7.3 31.102 Characteristics of the USIM Application

This document defines the USIM application for 3G telecom network operation. The present document specifies, command parameters, file structures and content, security functions and the application protocol to be used on the interface between UICC (USIM) and ME.

Release 99	Document No.	Version	Status	Issued date	Location ⁽¹⁾
(2)	ARIB/ TTC				
	CWTS				
	ETSI				
	T1				
	TTA				
Release 4	Document No.	Version	Status	Issued date	Location ⁽¹⁾
(2)	ARIB/ TTC				
	CWTS				
	ETSI				
	T1				
	TTA				
Release 5	Document No.	Version	Status	Issued date	Location ⁽¹⁾
(2)	ARIB/ TTC				
	CWTS				
	ETSI				
	T1				
	TTA				

(1), (2) See Notes (1) and (2), § 5.1.2.1.1.

5.1.2.7.4 31.110 Numbering system for telecommunication IC card applications

This document describes the numbering system for Application IDentifiers (AID) for 3G telecommunication Integrated Circuits (IC) card applications. The numbering system provides a means for an application and related services offered by a provider to identify if a given card contains the elements required by its application and related services.

Release 99	Document No.	Version	Status	Issued date	Location ⁽¹⁾
(2)	ARIB/ TTC				
	CWTS				
	ETSI				
	T1				
	TTA				
Release 4	Document No.	Version	Status	Issued date	Location ⁽¹⁾
(2)	ARIB/ TTC				
	CWTS				
	ETSI				
	T1				
	TTA				
Release 5	Document No.	Version	Status	Issued date	Location ⁽¹⁾
(2)	ARIB/ TTC				
	CWTS				
	ETSI				
	T1				
	TTA				

(1), (2) See Notes ⁽¹⁾ and ⁽²⁾, § 5.1.2.1.1.

5.1.2.7.5 31.111 USIM application toolkit (USAT)

This document defines the interface between the UICC and the Mobile Equipment (ME), and mandatory ME procedures, specifically for "USIM Application Toolkit". USAT is a set of commands and procedures for use during the network operation phase of 3G, in addition to those defined in TS 31.101.

Release 99	Document No.	Version	Status	Issued date	Location ⁽¹⁾
(2)	ARIB/ TTC				
	CWTS				
	ETSI				
	T1				
	TTA				
Release 4	Document No.	Version	Status	Issued date	Location ⁽¹⁾
(2)	ARIB/ TTC				
	CWTS				
	ETSI				
	T1				
	TTA				
Release 5	Document No.	Version	Status	Issued date	Location ⁽¹⁾
(2)	ARIB/ TTC				
	CWTS				
	ETSI				
	T1				
	TTA				

(1), (2) See Notes (1) and (2), § 5.1.2.1.1.

5.1.2.7.6 31.112 USIM Application Toolkit (USAT) interpreter architecture

This document defines the overall architecture for the USAT Interpreter system including the role models, system architecture and information flow.

Release 5	Document No.	Version	Status	Issued date	Location ⁽¹⁾
(2)	ARIB/ TTC				
	CWTS				
	ETSI				
	T1				
	TTA				

(1),(2) See Notes ⁽¹⁾ and ⁽²⁾, § 5.1.2.1.1.

5.1.2.7.7 31.113 USAT Interpreter Byte Codes

This document specifies the byte codes that are recognised by an USAT Interpreter. The primary purpose of the byte codes is to provide efficient programmatic access to the SIM Application Toolkit commands.

Release 5	Document No.	Version	Status	Issued date	Location ⁽¹⁾
(2)	ARIB/ TTC				
	CWTS				
	ETSI				
	T1				
	TTA				

(1),(2) See Notes ⁽¹⁾ and ⁽²⁾, § 5.1.2.1.1.

5.1.2.7.8 31.120 Physical, Electrical and Logical Test Specification

This document tests the physical, electrical and logical requirements as specified in TS 31.101.

Release 99	Document No.	Version	Status	Issued date	Location ⁽¹⁾
(2)	ARIB/ TTC				
	CWTS				
	ETSI				
	T1				
	TTA				
Release 4	Document No.	Version	Status	Issued date	Location ⁽¹⁾
(2)	ARIB/ TTC				
	CWTS				
	ETSI				
	T1				
	TTA				
Release 5	Document No.	Version	Status	Issued date	Location ⁽¹⁾
(2)	ARIB/ TTC				
	CWTS				
	ETSI				
	T1				
	TTA				

(1), (2) See Notes ⁽¹⁾ and ⁽²⁾, § 5.1.2.1.1.

5.1.2.7.9 31.121 UICC-Terminal Interface; USIM Application Test specification

This document provides the UICC-Terminal Interface Conformance Test Specification between the 3G Terminal and USIM (Universal Subscriber Identity Module) as an application on the UICC and the Terminal for 3G telecom network operation.

Release 99	Document No.	Version	Status	Issued date	Location ⁽¹⁾
(2)	ARIB/ TTC				
	CWTS				
	ETSI				
	T1				
	TTA				
Release 4	Document No.	Version	Status	Issued date	Location ⁽¹⁾
(2)	ARIB/ TTC				
	CWTS				
	ETSI				
	T1				
	TTA				
Release 5	Document No.	Version	Status	Issued date	Location ⁽¹⁾
(2)	ARIB/ TTC				
	CWTS				
	ETSI				
	T1				
	TTA				

(1),(2) See Notes ⁽¹⁾ and ⁽²⁾, § 5.1.2.1.1.

5.1.2.7.10 31.122 USIM Conformance Test Specification

The present document provides the Conformance Test Specification for a UICC defined in TS 31.101 with Universal Subscriber Identity Module (USIM) defined in 3G TS 31.102.

Release 99	Document No.	Version	Status	Issued date	Location ⁽¹⁾
(2)	ARIB/ TTC				
	CWTS				
	ETSI				
	T1				
	TTA				
Release 4	Document No.	Version	Status	Issued date	Location ⁽¹⁾
(2)	ARIB/ TTC				
	CWTS				
	ETSI				
	T1				
	TTA				
Release 5	Document No.	Version	Status	Issued date	Location ⁽¹⁾
(2)	ARIB/ TTC				
	CWTS				
	ETSI				
	T1				
	TTA				

(1), (2) See Notes ⁽¹⁾ and ⁽²⁾, § 5.1.2.1.1.

5.1.2.7.11 22.048 Security mechanisms for (U)SIM application toolkit - stage 1

This document provides standardised security mechanisms in conjunction with the SIM Application Toolkit for the interface between a 3G or GSM PLMN Entity and a UICC at the functional level.

Release 4	Document No.	Version	Status	Issued date	Location ⁽¹⁾
(2)	ARIB/ TTC				
	CWTS				
	ETSI				
	T1				
	TTA				
Release 5	Document No.	Version	Status	Issued date	Location ⁽¹⁾
(2)	ARIB/ TTC				
	CWTS				
	ETSI				
	T1				
	TTA				

(1), (2) See Notes (1) and (2), § 5.1.2.1.1.

5.1.2.7.12 23.048 Security mechanisms for (U)SIM application toolkit - stage 2

This document specifies the structure of the Secured Packets in a general format and in implementations using Short Message Service Point to Point (SMS-PP) and Short Message Service Cell Broadcast (SMS-CB).

Release 4	Document No.	Version	Status	Issued date	Location ⁽¹⁾
(2)	ARIB/ TTC				
	CWTS				
	ETSI				
	T1				
	TTA				
Release 5	Document No.	Version	Status	Issued date	Location ⁽¹⁾
(2)	ARIB/ TTC				
	CWTS				
	ETSI				
	T1				
	TTA				

(1), (2) See Notes (1) and (2), § 5.1.2.1.1.

5.1.2.7.13 23.038 Alphabets and language specific information

This specification describes the language specific requirements for the terminals including character coding.

Release 99	Document No.	Version	Status	Issued date	Location ⁽¹⁾
(2)	ARIB/ TTC				
	CWTS				
	ETSI				
	T1				
	TTA				
Release 4	Document No.	Version	Status	Issued date	Location ⁽¹⁾
(2)	ARIB/ TTC				
	CWTS				
	ETSI				
	T1				
	TTA				
Release 5	Document No.	Version	Status	Issued date	Location ⁽¹⁾
(2)	ARIB/ TTC				
	CWTS				
	ETSI				
	T1				
	TTA				

(1), (2) See Notes ⁽¹⁾ and ⁽²⁾, § 5.1.2.1.1.

5.1.2.7.14 23.040 Technical realization of SMS point-to-point

This specification describes the point-to-point SMS.

Release 99	Document No.	Version	Status	Issued date	Location ⁽¹⁾
⁽²⁾	ARIB/ TTC				
	CWTS				
	ETSI				
	T1				
	TTA				
Release 4	Document No.	Version	Status	Issued date	Location ⁽¹⁾
⁽²⁾	ARIB/ TTC				
	CWTS				
	ETSI				
	T1				
	TTA				
Release 5	Document No.	Version	Status	Issued date	Location ⁽¹⁾
⁽²⁾	ARIB/ TTC				
	CWTS				
	ETSI				
	T1				
	TTA				

^{(1), (2)} See Notes ⁽¹⁾ and ⁽²⁾, § 5.1.2.1.1.

5.1.2.7.15 23.041 Technical realization of cell broadcast service (CBS)

This specification describes the point-to-multipoint CBS.

Release 99	Document No.	Version	Status	Issued date	Location ⁽¹⁾
⁽²⁾	ARIB/ TTC				
	CWTS				
	ETSI				
	T1				
	TTA				
Release 4	Document No.	Version	Status	Issued date	Location ⁽¹⁾
⁽²⁾	ARIB/ TTC				
	CWTS				
	ETSI				
	T1				
	TTA				
Release 5	Document No.	Version	Status	Issued date	Location ⁽¹⁾
⁽²⁾	ARIB/ TTC				
	CWTS				
	ETSI				
	T1				
	TTA				

^{(1), (2)} See Notes ⁽¹⁾ and ⁽²⁾, § 5.1.2.1.1.

5.1.2.7.16 23.042 Compression algorithm for text messaging services

This specification describes the compression algorithm for text messaging services.

Release 99	Document No.	Version	Status	Issued date	Location ⁽¹⁾
⁽²⁾ ARIB/ TTC					
CWTS					
ETSI					
T1					
TTA					
Release 4	Document No.	Version	Status	Issued date	Location ⁽¹⁾
⁽²⁾ ARIB/ TTC					
CWTS					
ETSI					
T1					
TTA					
Release 5	Document No.	Version	Status	Issued date	Location ⁽¹⁾
⁽²⁾ ARIB/ TTC					
CWTS					
ETSI					
T1					
TTA					

^{(1), (2)} See Notes ⁽¹⁾ and ⁽²⁾, § 5.1.2.1.1.

5.1.2.7.17 23.057 Mobile Execution Environment (MExE) - stage 2

This TS describes the functional capabilities and the security architecture of the Mobile Execution Environment.

Release 99	Document No.	Version	Status	Issued date	Location ⁽¹⁾
ARIB/ TTC					
CWTS					
	ETSI				
	T1				
	TTA				
Release 4	Document No.	Version	Status	Issued date	Location ⁽¹⁾
ARIB/ TTC					
CWTS					
	ETSI				
	T1				
	TTA				
Release 5	Document No.	Version	Status	Issued date	Location ⁽¹⁾
ARIB/ TTC					
CWTS					
	ETSI				
	T1				
	TTA				

⁽¹⁾ See Note ⁽¹⁾, § 5.1.2.1.1.

5.1.2.7.18 23.140 Multimedia Messaging Service - stage 2

This TS describes the MMS network architecture, the application protocol framework and the technical realization of service features needed to support the non-realtime Multimedia Messaging Service.

Release 99	Document No.	Version	Status	Issued date	Location ⁽¹⁾
ARIB/ TTC					
CWTS ETSI T1 TTA					
Release 4	Document No.	Version	Status	Issued date	Location ⁽¹⁾
ARIB/ TTC					
CWTS ETSI T1 TTA					
Release 5	Document No.	Version	Status	Issued date	Location ⁽¹⁾
ARIB/ TTC					
CWTS ETSI T1 TTA					

⁽¹⁾ See Note ⁽¹⁾, § 5.1.2.1.1.

5.1.2.7.19 27.005 Use of data terminal equipment – data circuit terminating equipment (DTE – DCE) interface for cell broadcast service (CBS)

This specification describes three interface protocols for control of SMS functions within a GSM mobile telephone from a remote terminal via an asynchronous interface.

Release 99		Document No.	Version	Status	Issued date	Location ⁽¹⁾
(2)	ARIB/ TTC					
	CWTS					
	ETSI					
	T1					
	TTA					
Release 4		Document No.	Version	Status	Issued date	Location ⁽¹⁾
(2)	ARIB/ TTC					
	CWTS					
	ETSI					
	T1					
	TTA					
Release 5		Document No.	Version	Status	Issued date	Location ⁽¹⁾
(2)	ARIB/ TTC					
	CWTS					
	ETSI					
	T1					
	TTA					

(1), (2) See Notes ⁽¹⁾ and ⁽²⁾, § 5.1.2.1.1.

5.1.2.7.20 27.007 AT command set for the user equipment (UE)

This specification describes a profile of AT commands and recommends that this profile be used for controlling mobile equipment (ME) functions and GSM network services from a terminal equipment (TE) through terminal adaptor (TA).

Release 99		Document No.	Version	Status	Issued date	Location ⁽¹⁾
(2)	ARIB/ TTC					
	CWTS					
	ETSI					
	T1					
	TTA					
Release 4		Document No.	Version	Status	Issued date	Location ⁽¹⁾
(2)	ARIB/ TTC					
	CWTS					
	ETSI					
	T1					
	TTA					
Release 5		Document No.	Version	Status	Issued date	Location ⁽¹⁾
(2)	ARIB/ TTC					
	CWTS					
	ETSI					
	T1					
	TTA					

(1), (2) See Notes ⁽¹⁾ and ⁽²⁾, § 5.1.2.1.1.

5.1.2.7.21 27.010 Terminal equipment to mobile station (TE-MS) multiplexer protocol

This specification describes a multiplexing protocol between a mobile station and an external data terminal for the purposes of enabling multiple channels to be established for different purposes (e.g. simultaneous SMS and data call).

Release 99	Document No.	Version	Status	Issued date	Location ⁽¹⁾
(2)	ARIB/ TTC				
	CWTS				
	ETSI				
	T1				
	TTA				
Release 4	Document No.	Version	Status	Issued date	Location ⁽¹⁾
(2)	ARIB/ TTC				
	CWTS				
	ETSI				
	T1				
	TTA				
Release 5	Document No.	Version	Status	Issued date	Location ⁽¹⁾
(2)	ARIB/ TTC				
	CWTS				
	ETSI				
	T1				
	TTA				

(1), (2) See Notes ⁽¹⁾ and ⁽²⁾, § 5.1.2.1.1.

5.1.2.7.22 27.103 Wide area network synchronization standard

This specification describes a definition of a wide area synchronization protocol. The synchronization protocol is based upon infrared mobile communication (IrMC) Level 4 for Release 99. The synchronization protocol is based upon SyncML from Release 4 onwards.

Release 99	Document No.	Version	Status	Issued date	Location ⁽¹⁾
⁽²⁾	ARIB/ TTC				
	CWTS				
	ETSI				
	T1				
	TTA				
Release 4	Document No.	Version	Status	Issued date	Location ⁽¹⁾
⁽²⁾	ARIB/ TTC				
	CWTS				
	ETSI				
	T1				
	TTA				
Release 5	Document No.	Version	Status	Issued date	Location ⁽¹⁾
⁽²⁾	ARIB/ TTC				
	CWTS				
	ETSI				
	T1				
	TTA				

^{(1), (2)} See Notes ⁽¹⁾ and ⁽²⁾, § 5.1.2.1.1.

5.1.2.7.23 23.227 Application and user interaction in the UE; Principles and specific requirements

This Technical Specification defines the principles for scheduling resources between applications in different application execution environment (e.g. MExE, USAT etc.) and internal and external peripherals (e.g. infra-red, Bluetooth, USIM, radio interface, MMI, memory etc.).

Release 4	Document No.	Version	Status	Issued date	Location ⁽¹⁾
(2)	ARIB/ TTC				
	CWTS				
	ETSI				
	T1				
	TTA				
Release 5	Document No.	Version	Status	Issued date	Location ⁽¹⁾
(2)	ARIB/ TTC				
	CWTS				
	ETSI				
	T1				
	TTA				

(1), (2) See Notes ⁽¹⁾ and ⁽²⁾, § 5.1.2.1.1.

5.1.2.8 System aspects

IMT-2000 CDMA Direct Spread specification also includes the following documents which are useful and related to this Recommendation.

5.1.2.8.1 TS 23.002 UMTS release 1999 network architecture

This specification describes the possible architectures of the mobile system.

5.1.2.8.2 TS 23.101 General UMTS architecture

This specification describes the basic physical and functional separation of UMTS. The content of this specification is limited to those features that are common to all UMTS networks independent of their origin. It identifies and names the reference points and functional groupings appearing at this level.

5.1.2.8.3 TS 23.107 QoS concept and architecture

This specification describes the framework for QoS in UMTS. The document shall be used as a living document which will cover all issues related QoS in UMTS.

5.1.2.8.4 TS 23.121 Architectural requirements for release 1999

This specification describes architectural requirements for release 1999 related to the evolution of the GSM platform towards UMTS with the overall goal of fulfilling the UMTS service requirements, support of roaming and support of new functionality, signalling systems and interfaces.

5.1.2.8.5 TR 23.930 Iu principles

This specification describes the requirements on the Iu and studies relevant principles to guide further standardization of the related interface(s).

5.1.2.8.6 TS 22.002 Bearer services supported by a GSM PLMN

This 3G specification describes a set of bearer services to be provided to 3G subscribers by a 3G network itself and in connection with other networks. This document is also be used as a reference for defining the corresponding required mobile network capabilities which are specified by means of the connection type concept.

5.1.2.8.7 TS 22.004 General on supplementary services

This specification describes a recommended set of supplementary services to the teleservices and bearer services which will be supported by a 3G network in connection with other networks as a basis for the definition of the network capabilities required.

5.1.2.8.8 TS 22.011 Service accessibility

This specification describes the service access procedures as presented to the user. The document contains definitions and procedures are provided for international roaming, national roaming and regionally provided service. These are mandatory in relation to the technical realization of the UE.

5.1.2.8.9 TS 22.016 International mobile equipment identities (IMEI)

This specification describes the principal purpose and use of unique equipment identities.

5.1.2.8.10 TS 22.022 Personalization of GSM ME mobile functionality specification – Stage 1

This specification describes functional specifications of five features to personalize UE. These features are called:

- network personalization;
- network subset personalization;
- service provider (SP) personalization;
- corporate personalization;
- UMTS subscriber identity module (USIM) personalization.

This specification describes requirements for UE, which provide these personalization features.

5.1.2.8.11 TS 22.024 Description of charge advice information (CAI)

This specification describes an overall view of how the charging advice supplementary service shall operate both in the network and within the UE. The charging supplementary service is described in TS 22.086.

5.1.2.8.12 TS 22.030 Man-machine interface (MMI) of the mobile station

This specification describes the requirements for and gives guidelines on the MMI for calls on the 3G UE. This includes the requirements of the user procedures for call control and supplementary service control, the requirements on the physical input media and the output, such as indications and displayed information.

5.1.2.8.13 TS 22.034 High speed circuit switched data (HSCSD) – Stage 1

This specification describes the Stage 1 description of HSCSD. HSCSD is a feature that allows users subscribing to the general bearer services to access user rates that can be achieved with one or more traffic channel. HSCSD also defines a flexible use of air interface resources, which makes efficient and flexible use of higher user rates feasible.

5.1.2.8.14 TS 22.038 SIM application toolkit (SAT) – Stage 1

This specification describes the Stage 1 description of the SAT primarily from the subscriber's and serving environment's points of view, and does not deal with the details of the human interface itself. It includes information applicable to network operators, serving environments and terminal, switch and database manufacturers and contains the core requirements for a SAT which are sufficient to provide a complete service.

5.1.2.8.15 TS 22.041 Operator determined call barring

The feature operator determined barring (ODB) allows the network operator or service provider to regulate, by means of an exceptional procedure, access by the subscribers to 3G services, by the barring of certain categories of outgoing or incoming calls or of roaming. ODB shall take effect immediately and shall terminate ongoing calls and bar future calls. The purpose of this network feature is to be able to limit the service provider's financial exposure to new subscribers, or to those who have not promptly paid their bills. It may only be applied to the service provider's own subscribers.

5.1.2.8.16 TS 22.042 Network identity and time zone (NITZ) – Stage 1

The feature NITZ provides the means for serving networks to transfer current identity, time, daylight saving time and the local time zone to user equipment storage and use.

5.1.2.8.17 TS 22.057 Mobile station application execution environment (MExE) – Stage 1

This specification describes the Stage 1 description of the MExE.

5.1.2.8.18 TS 22.060 General packet radio service (GPRS) – Stage 1

This specification describes the Stage 1 description of the GPRS.

5.1.2.8.19 TS 22.066 Support of mobile number portability (MNP) – Stage 1

This specification describes the Stage 1 description of the support of MNP between networks in the same country. It is in response to a study mandate agreed between the European Commission and ETSI under order voucher ETSI/97/M-251.

5.1.2.8.20 TS 22.067 Priority set-up service – Stage 1 (ASCI spec)

This specification describes the Stage 1 description of the enhanced multi-level precedence and pre-emption (eMLPP) service. This service has two parts: precedence and pre-emption. Precedence involves assigning a priority level to a call in combination with fast call set-up. Pre-emption involves the seizing of resources, which are in use by a call of a lower precedence, by a higher level precedence call in the absence of idle resources. Pre-emption can also involve the disconnection of an on-going call of lower precedence to accept an incoming call of higher precedence.

5.1.2.8.21 TS 22.071 Location services (LCS) – Stage 1

LCS is a network provided enabling technology consisting of standardized service capabilities which enables the provision of location applications. This application may be service provider specific. The description of the numerous and varied possible location applications which are enabled by this technology are outside the scope of this specification. However, clarifying examples

of how the functionality being specified may be used to provide specific LCS is included in various sections of the specification.

5.1.2.8.22 TS 22.072 Call deflection (CD) – Stage 1

CD enables the served mobile subscriber to respond to an incoming call offered by the network by requesting redirection of this call to another number specified in the response. The CD supplementary service can only be invoked before the connection is established by the served mobile subscriber, i.e. in response to the offered call, or during the period that the served subscriber is being informed of the call. The served subscriber's ability to originate calls is unaffected by the CD supplementary service.

5.1.2.8.23 TS 22.078 Customized applications for mobile network enhanced logic (CAMEL) – Stage 1

This specification describes the Stage 1 description for CAMEL feature which provides the mechanisms to support services consistently independently of the serving network. The CAMEL features shall facilitate service control of operator specific services external from the serving network. The CAMEL feature is a network feature and not a supplementary service. It is a tool to help the network operator to provide the subscribers with the operator specific services even when roaming outside the home network.

5.1.2.8.24 TS 22.079 Support of optimal routing – Stage 1

Support of optimal routing is a network feature to reduce the number of unnecessary inter-network call legs when the subscriber is roaming.

5.1.2.8.25 TS 22.081 Line identification supplementary services – Stage 1

This specification describes the supplementary services belonging to the group line identification supplementary services. The group of line identification supplementary services is divided into the following four supplementary services:

- CLIP: calling line identification presentation (clause 1);
- CLIR: calling line identification restriction (clause 2);
- COLP: connected line identification presentation (clause 3);
- COLR: connected line identification restriction (clause 4).

5.1.2.8.26 TS 22.082 Call forwarding (CF) supplementary services – Stage 1

This specification describes the supplementary services belonging to the group call offering supplementary services.

The group of supplementary services call offering supplementary services is divided into four different supplementary services:

- call forwarding unconditional (§ 1);
- call forwarding on mobile subscriber busy (§ 2);
- call forwarding on no reply (§ 3);
- call forwarding on mobile subscriber not reachable (§ 4).

5.1.2.8.27 TS 22.083 Call waiting (CW) and call hold (HOLD) supplementary services – Stage 1

This specification describes the supplementary services belonging to the group call completion supplementary services which are divided into the following two supplementary services:

- call waiting (clause 1);
- call hold (clause 2).

5.1.2.8.28 TS 22.084 Multiparty (MPTY) supplementary service – Stage 1

This supplementary service provides a mobile subscriber with the ability to have a multi-connection call, i.e. a simultaneous communication with more than one party.

5.1.2.8.29 TS 22.085 Closed user group (CUG) supplementary services – Stage 1

The CUG supplementary service enables subscribers, connected to a network and possibly also other networks, to form CUGs to and from which access is restricted. A specific user may be a member of one or more CUGs. Members of a specific CUG can communicate among each other but not, in general, with users outside the group.

5.1.2.8.30 TS 22.086 Advice of charge (AoC) supplementary services – Stage 1

These services are designed to supply to a mobile user sufficient information to allow a real-time estimate to be made of the bill which will eventually be levied in the home public land mobile network (PLMN) on the mobile station subscriber.

5.1.2.8.31 TS 22.087 User-to-user signalling (UUS) – Stage 1

The UUS supplementary service allows a mobile subscriber to send/receive a limited amount of information to/from another network or ISDN subscriber over the signalling channel in association with a call to the other subscriber.

5.1.2.8.32 TS 22.088 Call barring (CB) supplementary services – Stage 1

The call restriction supplementary services allow the possibility for a mobile subscriber to have barring of certain categories of outgoing or incoming calls at the mobile subscribers access.

The group of call restriction services includes two supplementary services:

- barring of outgoing calls;
- barring of incoming calls.

By use of subscription options, the mobile subscriber can at provision time select a set of one or more barring programs to determine the categories of calls to be barred. The following categories are defined:

- all outgoing calls;
- outgoing international calls;
- outgoing international calls except those directed to the home PLMN country;
- all incoming calls;
- incoming calls when roaming outside the home PLMN country.

5.1.2.8.33 TS 22.090 Unstructured supplementary service data (USSD) – Stage 1

There are two modes of USSD: MMI-mode and application mode. MMI-mode USSD is for the transparent transport of MMI strings entered by the user to the network and for the transparent transport of text strings from the network that are displayed by the mobile for user information.

Application mode USSD is for the transparent transport of data between the network and the mobile station. Application mode USSD is intended to be used by applications in the network and their peer applications in the UE.

The communication over the radio interface takes place on the signalling channels using short dialogues with peak data throughput rate capabilities of up to approximately 600 bits/s outside of a call and 1 000 bits/s during a call.

5.1.2.8.34 TS 22.091 Explicit call transfer (ECT) supplementary service – Stage 1

The ECT supplementary service enables the served mobile subscriber (subscriber A) who has two calls, each of which can be an incoming or outgoing call, to connect the other parties in the two calls and release the served mobile subscribers own connection.

5.1.2.8.35 TS 22.093 Call completion to busy subscriber (CCBS) – Stage 1

In the situation when subscriber A encounters a network determined user busy (NDUB) destination B, the subscriber A can request the CCBS supplementary service (i.e. activate a CCBS request against destination B). The network will then monitor the wanted destination B for becoming idle.

When the wanted destination B becomes idle, then the network will wait a short time in order to allow destination B to make an outgoing call. If destination B does not make any outgoing call within this time, then the network shall automatically recall subscriber A.

5.1.2.8.36 TS 22.096 Calling name presentation (CNAP) – Stage 1

The CNAP supplementary service enables the called party to receive the calling name information of the calling party.

5.1.2.8.37 TS 22.097 Multiple subscriber profile (MSP) – Stage 1

MSP is an optional service to enable mobile subscribers to have several profiles associated with a single subscriber identity (SIM) and a single international mobile subscriber identity (IMSI), with each profile being a subscription option. Each profile may be used for mobile originated and mobile terminated calls.

Up to four different profiles can be provisioned against a subscriber using the MSP feature. This will allow the subscriber to separate her telecommunication service needs into different identities (e.g. business and home).

5.1.2.8.38 TS 22.100 UMTS phase 1 capabilities

This specification describes contains how the definition of the UMTS system will be achieved in a phased approach. This document also specifies the requirements for release 99 of UMTS. Some requirements which are necessary to ensure a smooth transition to later releases are also indicated. This document should, however, be read in conjunction with the other 22.000 series documents which provide a complete description of the requirements for UMTS release 1999 and beyond.

5.1.2.8.39 TS 22.101 UMTS service principles

This specification describes the service principles of the UMTS.

5.1.2.8.40 TS 22.105 Services and service capabilities

Pre-UMTS systems have largely standardized the complete sets of bearer services, teleservices and supplementary services which they provide. One major difference between UMTS and pre-UMTS systems is that service capabilities rather than services are standardized for UMTS, allowing service differentiation and system continuity. This document describes how and what kind of services the UMTS user has access to.

5.1.2.8.41 TS 22.115 Service aspects: charging and billing

This specification describes the service aspects of charging and billing of the UMTS.

This standard is not intended to duplicate existing standards or standards being developed by other groups on these topics, and will reference these where appropriate. This standard will elaborate on the charging requirements described in the charging principles in TS 22.101 UMTS service principles. It will allow the generation of accurate charging information to be used in the commercial and contractual relationships between the parties concerned.

5.1.2.8.42 TS 22.121 Virtual home environment (VHE)

This specification describes the content of the Stage 1 requirement for realization of VHE. VHE is defined as a concept for personal service environment (PSE) portability across network boundaries and between terminals. The concept of the VHE is such that users are consistently presented with the same personalized features, user interface customization and services in whatever network and whatever terminal (within the capabilities of the terminal and the network), wherever the user may be located.

A key feature to support VHE is the ability to build services using a standardized application interface.

5.1.2.8.43 TS 22.129 Handover requirements between UMTS and GSM or other radio systems

This specification describes service requirements for handover (terms are defined below) within UMTS systems and between UMTS, other IMT-2000 family members and second generation systems. Particular emphasis has been placed on the description of requirements for handover between UMTS and GSM but requirements specific to other systems are incorporated as required.

5.1.2.8.44 TS 22.135 Multicall

This specification describes multicall scenarios and requirements for UMTS phase 1 release 1999.

Multicall feature specifies functionality and interactions related to usage of several simultaneous bearers between a terminal and a network. Multicall features allows both circuit-switched call(s) and packet session(s) to exist simultaneously.

5.1.2.8.45 TR 22.971 Automatic establishment of roaming relations

This report describes a proposed framework for commercial and technical interworking between UMTS home environments and serving networks who have no direct prior commercial agreements with each other.

This text is applicable to UMTS standardization within ETSI, and is produced with the intent to clarify the concepts involved, and identify those areas which require standardization.

5.1.2.8.46 TR 22.975 Advanced addressing

This report describes the requirements for numbering and addressing for UMTS. This technical report is aimed at generating discussion and should be agreed with ETSI WG NA2. The responsibility for developing of numbering and addressing schemes for all networks being in ETSI NA2.

5.1.2.8.47 TS 21.133 Security threats and requirements

Detailed security requirements.

5.1.2.8.48 TS 33.102 Security architecture

Provides a specification of all security mechanisms and protocols, except algorithms.

5.1.2.8.49 TS 33.103 Security integration guidelines

5.1.2.8.50 TS 33.105 Cryptographic algorithm requirements

Defines requirements for standard cipher and integrity algorithm.

5.1.2.8.51 TS 33.106 Lawful interception requirements

Defines all requirements for network based lawful interception.

5.1.2.8.52 TS 33.120 Security objectives and principles

Elaborates on the basic principles underlying the security.

5.1.2.8.53 TR 33.901 Criteria for cryptographic algorithm design process

This report describes the process used to design cipher and integrity algorithm.

5.1.2.8.54 TR 33.902 Formal analysis of the 3G authentication protocol with modified sequence number management

Formal analysis using BAN and temporal logic of authentication mechanism.

5.1.2.8.55 TS 26.071 AMR speech codec: general description

This specification describes an introduction to the set of the adaptive multi-rate (AMR) specifications.

5.1.2.8.56 TS 26.090 AMR speech codec: transcoding functions

This specification describes a detailed description of the AMR speech codec transcoding functions.

5.1.2.8.57 TS 26.091 AMR speech codec: error concealment of lost frames

This specification describes example procedures for the error concealment, also called frame substitution or muting procedure, of lost speech or silence indicator frames.

5.1.2.8.58 TS 26.092 AMR speech codec: comfort noise aspects

This specification describes the detailed requirements for the correct operation of the background acoustic noise evaluation, noise parameter encoding/decoding and comfort noise generation for the AMR speech codec during source controlled rate (SCR) operation.

5.1.2.8.59 TS 26.093 AMR speech codec: source controlled rate (SCR) operation

This specification describes the operation of the AMR speech codec during SCR operation.

5.1.2.8.60 TS 26.094 AMR speech codec: voice activity detector (VAD)

This specification describes two alternatives for the VAD to be used during SCR operation in conjunction with the AMR codec.

5.1.2.8.61 TS 26.110 Codec for circuit-switched multimedia telephony service: general description

This specification describes an introduction to the set of specifications for the support of circuit-switched 3G-324M multimedia telephony service.

5.1.2.8.62 TS 26.111 Codec for circuit-switched multimedia telephony service: modifications to ITU-T Recommendation H.324

This specification describes the modifications applicable to the ITU-T Recommendation H.324, Annex C for the support of circuit-switched 3G-324M multimedia telephony service.

5.1.2.8.63 TR 26.911 Codec for circuit-switched multimedia telephony service: terminal implementor's guide

This report describes non-mandatory Recommendations for the use of the different codec implementation options for the circuit-switched 3G-324M multimedia telephony service based on ITU-T Recommendation H.324, Annex C. These Recommendations address issues specific to the third generation operating environment, including guaranteeing sufficient error resilience and inter-working between terminals.

5.1.2.9 Vocabulary

Document 21.905 is a collection of terms, definitions and abbreviations related to the baseline documents defining the objectives and systems framework. This document provides a tool for further work on the technical documentation and facilitates their understanding.

Release 99		Document No.	Version	Status	Issued date	Location ⁽¹⁾
(2)	ARIB/ TTC					
	CWTS					
	ETSI					
	T1					
	TTA					
Release 4		Document No.	Version	Status	Issued date	Location ⁽¹⁾
(2)	ARIB/ TTC					
	CWTS					
	ETSI					
	T1					
	TTA					
Release 5		Document No.	Version	Status	Issued date	Location ⁽¹⁾
(2)	ARIB/ TTC					
	CWTS					
	ETSI					
	T1					
	TTA					

(1), (2) See Notes ⁽¹⁾ and ⁽²⁾, § 5.1.2.1.1.

5.1.2.10 SDO's complete system standard

SDO	Location (Release 99)
ARIB	
CWTS	
TTC	
ETSI	
T1	
TTA	
SDO	Location (Release 4)
ARIB	
CWTS	
TTC	
ETSI	
T1	
TTA	
SDO	Location (Release 5)
ARIB	
CWTS	
TTC	
ETSI	
T1	
TTA	