

TSG-RAN Meeting #18
New-Orleans, USA, 03 - 06 December 2002

RP-020734

Title: Agreed CR (Rel-5) to TS 25.308
Source: TSG-RAN WG2
Agenda item: 7.2.5

Doc-1st-	Status-	Spec	CR	Rev	Phase	Subject	Cat	Version-	Version
R2-023206	Agreed	25.308	003	2	Rel-5	Alignment with the physical layer specifications	F	5.2.0	5.3.0
R2-022705	Agreed	25.308	004	-	Rel-5	Generation of RLC Status Reports to coordinate with MAC-hs reset	F	5.2.0	5.3.0

CR-Form-v7

CHANGE REQUEST

⌘ **25.308 CR 003** ⌘ rev **2** ⌘ Current version: **5.2.0** ⌘

For **HELP** on using this form, see bottom of this page or look at the pop-up text over the ⌘ symbols.

Proposed change affects: UICC apps ME Radio Access Network Core Network

Title:	⌘ Alignment with the physical layer specifications		
Source:	⌘ Motorola / Siemens		
Work item code:	⌘ HSDPA	Date:	⌘ 12/11/2002
Category:	⌘ F	Release:	⌘ Rel-5
	<i>Use <u>one</u> of the following categories:</i> F (correction) A (corresponds to a correction in an earlier release) B (addition of feature), C (functional modification of feature) D (editorial modification) Detailed explanations of the above categories can be found in 3GPP TR 21.900 .		<i>Use <u>one</u> of the following releases:</i> 2 (GSM Phase 2) R96 (Release 1996) R97 (Release 1997) R98 (Release 1998) R99 (Release 1999) Rel-4 (Release 4) Rel-5 (Release 5) Rel-6 (Release 6)

Reason for change:	⌘ Document updated to reflect recent changes in RAN1 TDD specifications.
	<p>With the completion of the majority of the work on HSDPA it was felt appropriate to clean-up the Stage 2 description to ensure:</p> <ol style="list-style-type: none"> 1. correctness 2. alignment with Stage 3 specifications in RAN WG2 and RAN WG3 3. avoidance of duplication of text in order to minimise conflicting specifications <p>Open Issues to resolve during meeting – A few statements with square brackets remain (highlighted in blue) – we need to decide if the need for the square brackets persists or text can be agreed or deleted. (sub-clauses 5.2.2.1, 7.4, 10)</p>
Summary of change:	⌘ Changes mainly to signalling parameter descriptions: <ul style="list-style-type: none"> • Abbreviations • Models of the UE's physical layer for TDD • HS-SICH added • Transport channel attributes • Signalling parameters description added (HARQ Information, TFRI) • HS-SCCH Cyclic Sequence Number description added • Resource management description. <p>Various editorial changes.</p>
Consequences if not approved:	⌘ RAN1 and RAN2 specifications will be misaligned

Clauses affected:	⌘ 3.2, 5.2.2.2, 5.2.4.2, 5.3, 8, 10 3.1, 5.1, 5.2.1, 5.2.2.1, 5.2.4.2, 6.1.1, 6.1.2, 6.1.4, 6.2, 6.2.3, 7.2, 7.3, 7.4, 8.1,
--------------------------	---

		8.1.9, 8.2, 8.2.2			
Other specs affected:		Y	N		
	⌘		X	Other core specifications	⌘
			X	Test specifications	
			X	O&M Specifications	
Other comments:	⌘				

How to create CRs using this form:

Comprehensive information and tips about how to create CRs can be found at <http://www.3gpp.org/specs/CR.htm>. Below is a brief summary:

- 1) Fill out the above form. The symbols above marked ⌘ contain pop-up help information about the field that they are closest to.
- 2) Obtain the latest version for the release of the specification to which the change is proposed. Use the MS Word "revision marks" feature (also known as "track changes") when making the changes. All 3GPP specifications can be downloaded from the 3GPP server under <ftp://ftp.3gpp.org/specs/> For the latest version, look for the directory name with the latest date e.g. 2001-03 contains the specifications resulting from the March 2001 TSG meetings.
- 3) With "track changes" disabled, paste the entire CR form (use CTRL-A to select it) into the specification just in front of the clause containing the first piece of changed text. Delete those parts of the specification which are not relevant to the change request.

1 Scope

The present document is a technical specification of the overall support of High Speed Downlink Packet Access in UTRA.

2 References

The following documents contain provisions which, through reference in this text, constitute provisions of the present document.

- References are either specific (identified by date of publication, edition number, version number, etc.) or non-specific.
- For a specific reference, subsequent revisions do not apply.
- For a non-specific reference, the latest version applies. In the case of a reference to a 3GPP document (including a GSM document), a non-specific reference implicitly refers to the latest version of that document *in the same Release as the present document*.

[1] 3GPP TR 25.855: "High Speed Downlink Packet Access (HSDPA): Overall UTRAN Description".

[2] 3GPP TS 25.321: "Medium Access Control (MAC) protocol specification".

3 Definitions and abbreviations

3.1 Definitions

For the purposes of the present document, the following terms and definitions apply.

Data block: The data transmitted to one UE on HS-DSCH in one TTI.

Priority class: One flow of data within a HS-DSCH transport channel. One HS-DSCH can transport several priority classes (only one priority class per TTI).

HARQ Process: Peer state machines capable of achieving error correction by retransmission. One process can be used only for one data block at a time.

HARQ Entity: Consists of all the HARQ processes of a UE, controlling all the available soft buffer capacity.

Serving HS-DSCH radio link: The radio link that the HS-PDSCH physical channel(s) allocated to the UE belongs to.

Serving HS-DSCH cell: The cell associated with the UTRAN access point performing transmission and reception of the serving HS-DSCH radio link for a given UE. The serving HS-DSCH cell is always part of the current active set of the UE.

Serving HS-DSCH Node B: A role a Node B may take with respect to a UE having one or several HS-PDSCHs allocated. The serving HS-DSCH Node B is the Node B controlling the serving HS-DSCH cell.

HS-SCCH set: a set of HS-SCCH which is used for HS-PDSCH allocation. There is a maximum of four HS-SCCHs in a given HS-SCCH set. There can be multiple HS-SCCH sets in one cell. HS-SCCH sets are independent, i.e. they can overlap or have no intersection.

Serving HS-SCCH set: the HS-SCCH set being used by a given UE for HS-PDSCH allocations.

MAC-d flow: a MAC-d flow is a flow of MAC-d PDUs which belong to logical channels which are MAC-d multiplexed. ~~using the same C/T field.~~

3.2 Abbreviations

For the purposes of the present document, the following abbreviations apply:

16QAM	16 Quadrature Amplitude Modulation
CCTrCH	Coded Composite Transport Channel
CQI	Channel Quality Indicator
HARQ	Hybrid Automatic Repeat Request
HSDPA	High Speed Downlink Packet Access
HS-DSCH	High Speed Downlink Shared Channel
HS-PDSCH	High Speed Physical Downlink Shared Channel
HS-SCCH	Shared Control Channel for HS-DSCH
HS-SICH	Shared Information Channel for HS-DSCH
MCS	Modulation and Coding scheme
NW	Network
QPSK	Quadrature Phase Shift Keying
TFCI	Transport Format Combination Indicator
TFRC	Transport Format Resource Combination
TFRI	Transport Format and Resource Indicator
TPC	Transmit Power Control
TSN	Transmission Sequence Number
UE	User Equipment

4 Background and Introduction

High Speed Downlink Packet Access is based on techniques such as adaptive modulation and hybrid ARQ to achieve high throughput, reduce delay and achieve high peak rates.

It relies on a new type of transport channel, the HS-DSCH, which is terminated in the Node B.

5 Basic structure of HS-DSCH

5.1 Protocol structure

The ~~HSDPA~~[HS-DSCH](#) functionality should be able to operate in an environment where certain cells are not updated with ~~HSDPA~~[HS-DSCH](#) functionality. The PDCP, RLC and MAC-d layers are unchanged from the Release '99 and Release 4 architecture.

RLC can operate in either AM or UM mode (but not in TM mode due to ciphering).

PDCP can be configured either to perform or not to perform header compression.

MAC-d is retained in the S-RNC. Transport channel type switching is therefore feasible.

The new functionalities of hybrid ARQ and ~~HSDPA~~[HS-DSCH](#) scheduling are included in the MAC layer. In the UTRAN these functions are included in a new entity called MAC-hs located in Node B. The transport channel that the ~~HSDPA~~[HS-DSCH](#) functionality ~~will~~ uses is called HS-DSCH (High Speed Downlink Shared Channel) and is controlled by the MAC-hs.

Two MAC protocol configurations are possible on the UTRAN side:

- Configuration with MAC-c/sh: In this case, the MAC-hs in Node B is located below MAC-c/sh in CRNC. MAC-c/sh shall provide functions to ~~HSDPA already included for~~[HS-DSCH identical to those provided for the DSCH](#) in the Release '99. The HS-DSCH FP (frame protocol) will handle the data transport from SRNC to CRNC (if the Iur interface is involved) and between CRNC and the Node B.

- Configuration without MAC-c/sh: In this case, the CRNC does not have any user plane function for the HS-DSCH. MAC-d in SRNC is located directly above MAC-hs in Node B, i.e. in the HS-DSCH user plane the SRNC is directly connected to the Node B, thus bypassing the CRNC.

Both configurations are transparent to both the UE and Node B. Figures 5.1-1 and 5.1-2 show the respective radio interface protocol architecture with termination points for the above two configurations.

The same architecture supports both FDD and TDD modes of operation, though some details of the associated signalling for HS-DSCH are different.

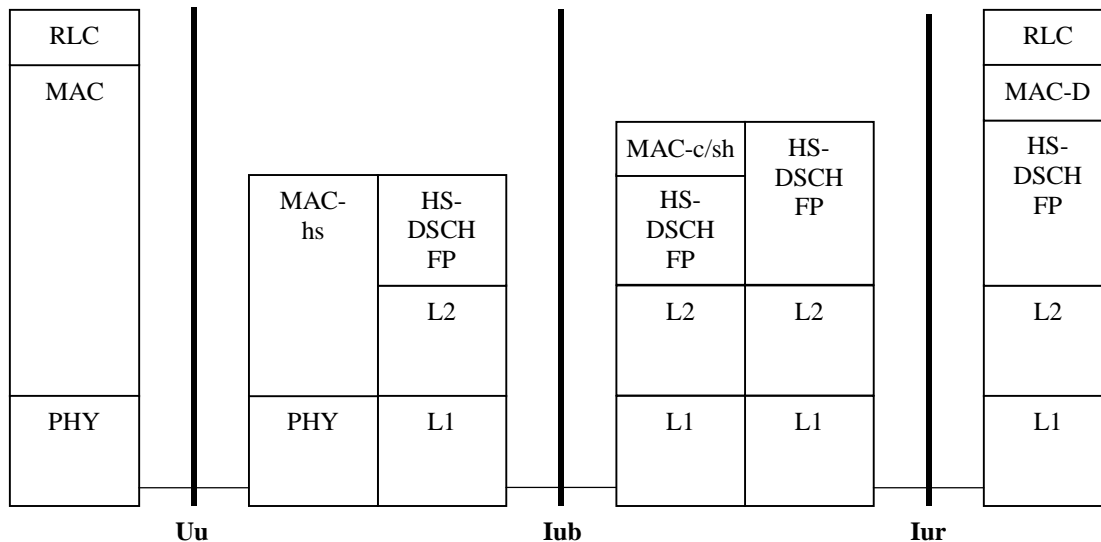

Figure 5.1-1: Protocol Architecture of **HSDPA** HS-DSCH, Configuration with MAC-c/sh

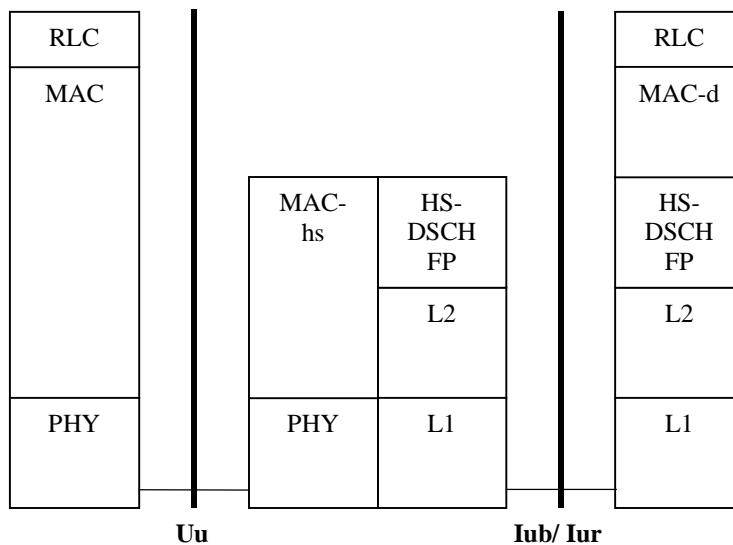

Figure 5.1-2: Protocol Architecture of **HSDPA** HS-DSCH, Configuration without MAC-c/sh

5.2 Basic physical structure

5.2.1 HS-DSCH Characteristics

The HS-DSCH transport channel has the following characteristics:

- An HS-DSCH transport channel is processed and decoded from one CCTrCH;

- There is only one CCTrCH of HS-DSCH type per UE;
- The CCTrCH can be mapped to one or several physical channels;
- There is only one HS-DSCH per CCTrCH;
- Existence in downlink only;
- Possibility to use beam forming;
- Possibility of applying link adaptation techniques other than power control;
- Possibility to be broadcast in the entire cell;
- Always associated with a DPCH and one or more shared physical control channels (HS-SCCHs).

~~As in Release '99 it shall be possible to map certain logical channels to DCH and HS-DSCH simultaneously.~~

5.2.2 DL HSDPA HS-DSCH Physical layer model

5.2.2.1 FDD Downlink Physical layer Model

DCH model with HS-DSCH

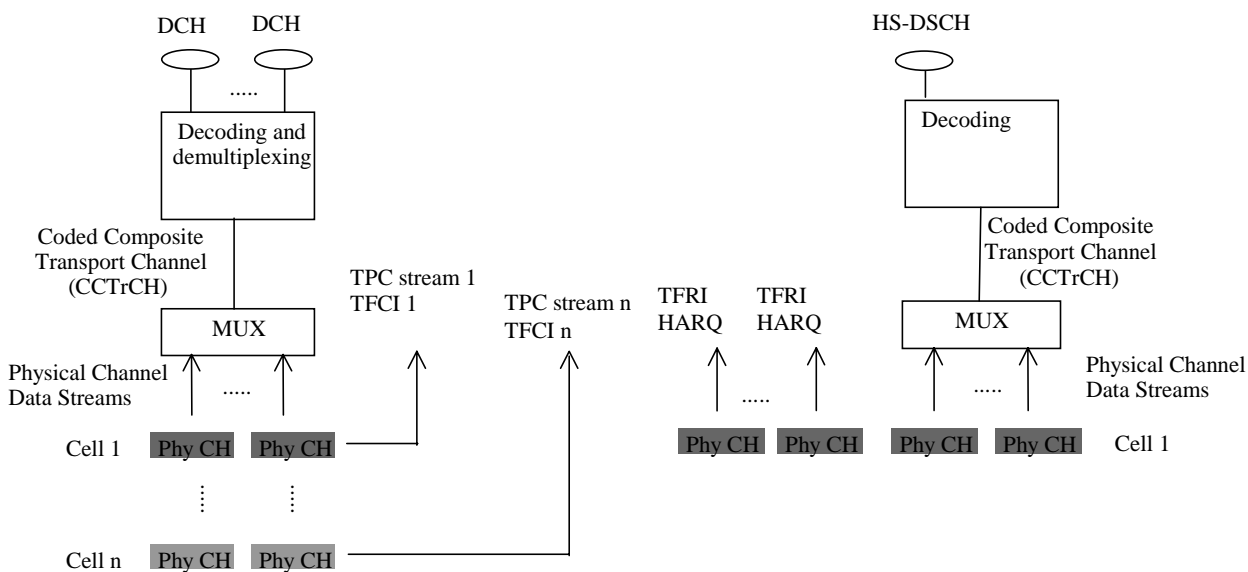

Figure 5.2.2.1-1: Model of the UE's Downlink physical layer - HS-PDSCH with associated DPCH. HS-PDSCH is transmitted from cell 1 in this figure

The basic downlink channel configuration consists of one or several HS-PDSCHs along with an associated DPCH combined with a number of separate shared physical control channels, HS-SCCHs ~~in combination with the HS-PDSCH~~. The set of shared physical control channels ~~What a UE is~~ allocated to the UE at a given time is called an HS-SCCH set. ~~The maximum number of HS-SCCHs in an HS-SCCH set is four.~~ The UTRAN may use more than one HS-SCCH set in one given cell. There is a fixed time offset between the start of the HS-SCCH information and the start of the corresponding HS-PDSCH subframe ~~HS-DSCH TTI~~.

The UE is provided at HS-PDSCH configuration/re-configuration via RRC signalling with one HS-SCCH set. :

~~[a list of HS-SCCH sets. The Serving HS-SCCH set is provided/modified by the Node-B to the UE using Node-B signalling]; or~~

~~[one HS-SCCH set].~~

The number of HS-SCCHs in a HS-SCCH set as seen from the UE's point-of-view can range from a minimum of one HS-SCCH to a maximum of four HS-SCCHs. The UE shall monitor continuously all the HS-SCCHs in the allocated set.

A two-step signalling approach is used for indicating which UE has been scheduled and signalling the necessary information for the UE to decode the HS-PDSCHs.

For each HS-DSCH TTI, each Shared Control Channel (HS-SCCH) carries HS-DSCH-related downlink signalling for one UE. The following information is carried on the HS-SCCH:

- Transport Format and Resource Indicator (TFRI):
The TFRI includes information about the dynamic part of the HS-DSCH transport format, including transport block set size and modulation scheme. The TFRI also includes information about the set of physical channels (channelisation codes) onto which HS-DSCH is mapped in the corresponding HS-DSCH TTI.
- Hybrid-ARQ-related Information (HARQ information):
This includes the HARQ protocol related information for the corresponding HS-DSCH TTI (subclause 7.1.2.1) and information about the redundancy version.

The HS-SCCH carries a UE identity (via a UE-specific CRC) that identifies the UE for which it is carrying the information necessary for decoding the HS-PDSCH. The UE may also identify the HS-SCCH channel carrying information for it by descrambling the first part of the HS-SCCH by the UE identity.

The HS-PDSCH channelisation codes that are used in a given cell ~~need are~~ not ~~be~~ sent to the UE ~~by using~~ RRC signalling, ~~since The MAC hs in Node B can~~ HS-SCCH signals ~~the any~~ set of HS-PDSCH channelisation codes which are allocated to a UE for a given TTI.

The first part of the HS-SCCH contains the channelisation code set and the modulation scheme for the HS-DSCH allocation with the second part containing the transport block size and H-ARQ related information. One CRC is calculated over both parts and the UE id and attached to the HS-SCCH information.

~~A two-step signalling approach is used for indicating which UE has been scheduled and signalling the necessary information for the UE to decode the HS-PDSCH.~~

~~It consists of a downlink DPCH and a number of HS-SCCHs. For each HS-DSCH TTI, each Shared Control Channel (HS-SCCH) carries HS-DSCH-related downlink signalling for one UE. The number of HS-SCCHs as seen from the UE's point of view can range from a minimum of one HS-SCCH to a maximum of four HS-SCCHs.~~

~~The UE has the capability to monitor four HS-SCCHs simultaneously.~~

~~The UE identifies the HS-SCCH channel carrying information for it by descrambling the first part of the HS-SCCH by the UE identity. This part contains the channelisation code set and the modulation scheme for the HS-DSCH allocation with the second part containing the transport block size and H-ARQ related information. One CRC is calculated over both parts and attached to the HS-SCCH information.~~

In case of HS-DSCH transmission to the same UE in consecutive HS-DSCH TTIs, the same HS-SCCH should be used for the corresponding associated downlink signalling.

The upper layer signalling on the DCCH can be mapped to the DCCH mapped to the associated DPCH or the HS-DSCH, ~~as in the case of Release '99.~~

~~For each HS-DSCH TTI, each HS-SCCH carries HS-DSCH-related downlink signalling for one UE. The following information is carried on the HS-SCCH:~~

- ~~— Transport Format and Resource Indicator (TFRI):~~
The TFRI includes information about the dynamic part of the HS-DSCH transport format, including transport block set size and modulation scheme. The TFRI also includes information about the set of physical channels (channelisation codes) onto which HS-DSCH is mapped in the corresponding HS-DSCH TTI.
- ~~— Hybrid-ARQ-related Information (HARQ information):~~
This includes the HARQ protocol related information for the corresponding HS-DSCH TTI (subclause 7.1.2.1) and information about the redundancy version.

~~The HS-SCCH carries a UE identity (via a UE-specific CRC) that identifies the UE for which it is carrying the information necessary for decoding the HS-PDSCH.~~

[The HS-DSCH carries a UE identity that identifies the UE so that erroneous delivery of MAC-PDUs to MAC-d is avoided.]

~~There is a fixed time offset between the start of the HS-SCCH information and the start of the corresponding HS-DSCH TTI.~~

5.2.2.2 TDD Downlink Physical layer model

DCH model with HS-DSCH(s)

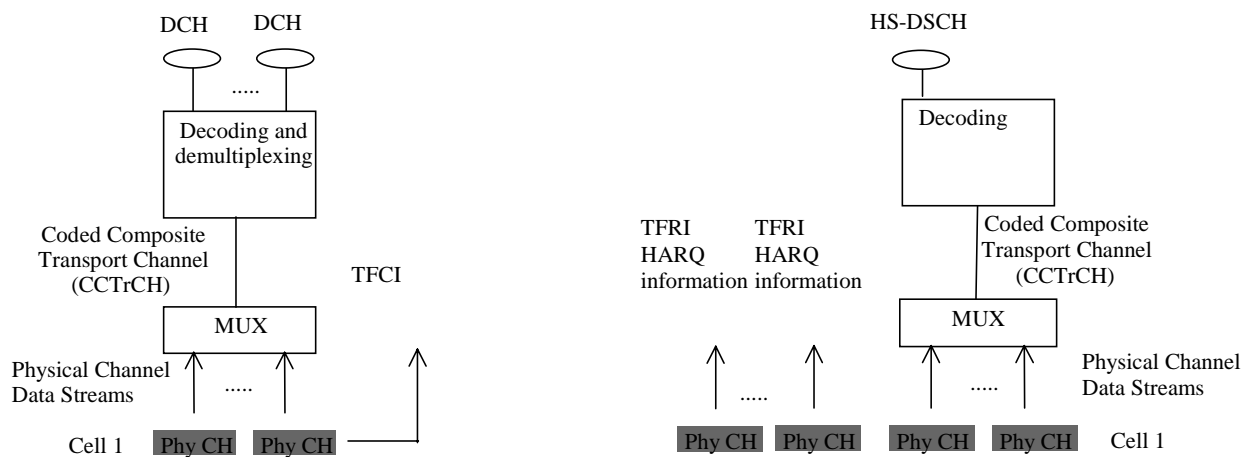

Figure 5.2.2.2-1: Model of the UE's physical layer (3.84 Mcps TDD)

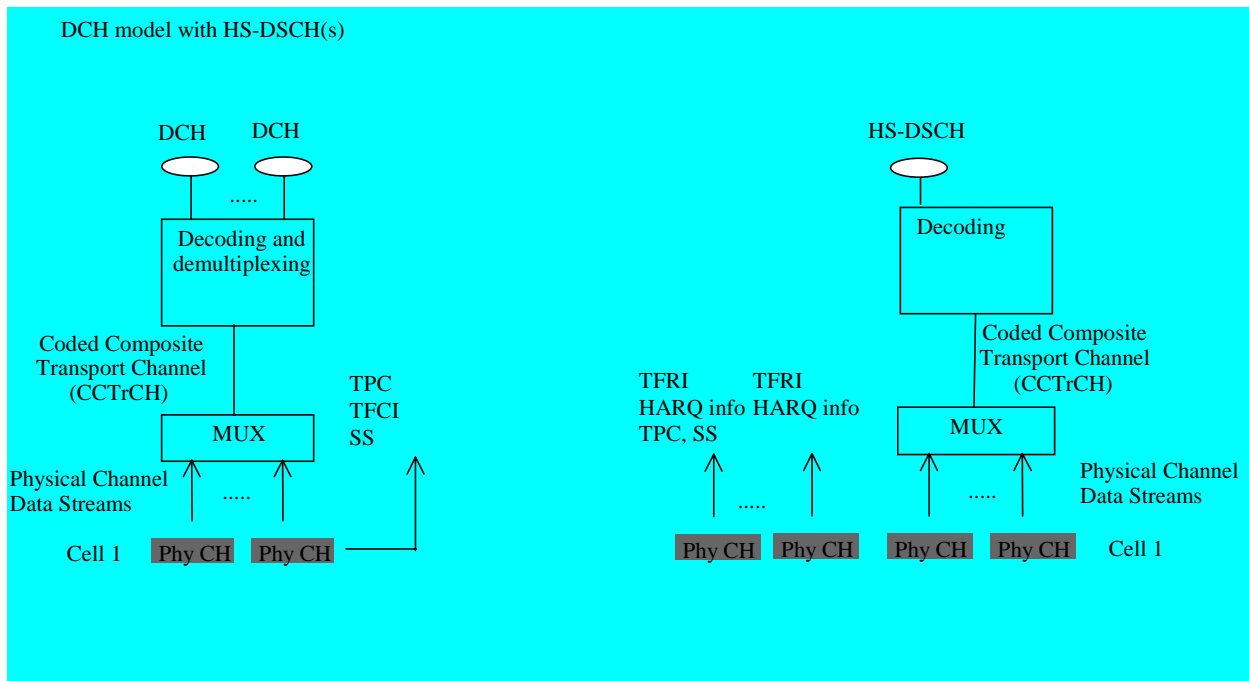
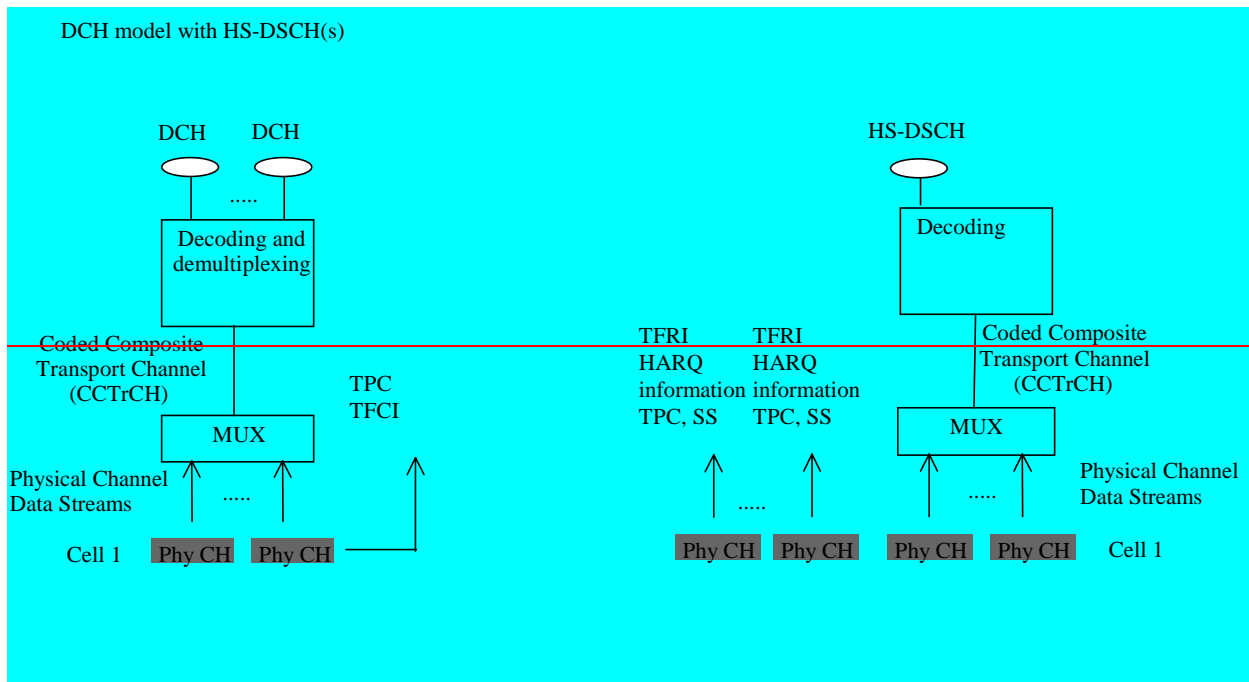

Figure 5.2.2.2-2: Model of the UE's physical layer (1.28 Mcps TDD)

The TDD overall downlink signalling structure is based on associated dedicated physical channels and shared physical control channels. The downlink signalling information for support of HS-DSCH is carried by the HS-SCCH.

As in Release '99, the associated dedicated physical channel can also be a fractionated channel for efficient resource usage with a corresponding repetition period in terms of TTIs. The UE is informed of an HS-DSCH allocation by means of a signalling message on an HS-SCCH. The UE shall be allocated a set of up to four HS-SCCHs, and shall monitor all of these HS-SCCHs continuously. In any given TTI, a maximum of one of these HS-SCCHs may be addressed to the UE. In the case that a UE detects a message for it on a specific HS-SCCH, then it may restrict its monitoring of HS-SCCHs to only that HS-SCCH in the next TTI.

5.2.3 UL ~~HSDPA~~ HS-DSCH Physical layer model

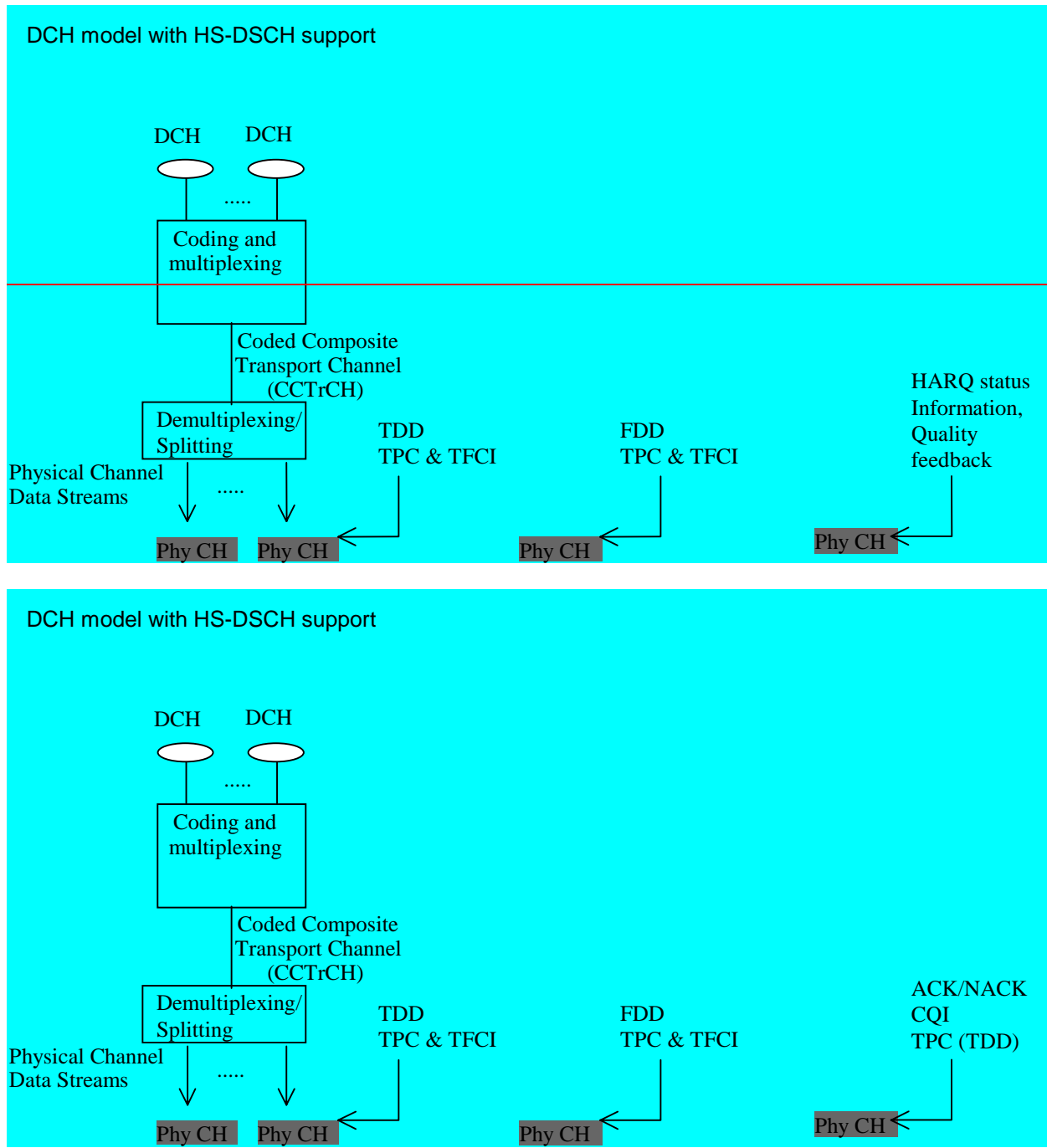

Figure 5.2.3-1: Model of the UE's Uplink physical layer

In FDD, the uplink signalling uses an additional DPCCCH with SF=256 that is code multiplexed with the existing dedicated uplink physical channels. The HS-DSCH related uplink signalling consists of H-ARQ acknowledgement and channel quality indicator.

In TDD, the UE shall use a shared uplink resource (the HS-SICH) for transmitting ACK/NACK and CQI information. The relation between the HS-SCCH in DL and shared the HS-SICH in UL resource can be is pre-defined and is not signalled dynamically on the HS-SCCH.

5.2.4 HSDPA HS-DSCH physical-layer structure in the code domain

5.2.4.1 FDD

HS-DSCH relies on channelisation codes at a fixed spreading factor, SF=16. A UE may be assigned multiple channelisation codes in the same TTI, depending on its UE capability. Furthermore, multiplexing of multiple UEs in the code domain within a HS-DSCH TTI is allowed.

5.2.4.2 TDD

HS-DSCH relies on one or more channelisation codes ~~at a fixed spreading factor, with SF=16 with either SF=16 or SF=1, but not both simultaneously~~. Transmission on one or more timeslots is also allowed. Furthermore, a combination of code multiplexing and time multiplexing by timeslot within a HS-DSCH TTI is allowed, ~~but the same set of channelisation codes must be used in all timeslots allocated to the HS-DSCH. The HS-DSCH TTI is not allowed to cross the frame (3.84 Mcps TDD) or the sub-frame (1.28 Mcps TDD) boundary.~~

5.3 Transport channel attributes

The following is a list of HS-DSCH transport channel attributes:

1. Transport block size - ~~dynamic for first transmission. An identical transport block size shall be applied for any retransmission. There shall be no support for blind transport format detection~~dynamic.
2. Transport block set size - ~~dynamic for first transmission. An identical transport block set size shall be applied for retransmission. There shall be no support for blind transport format detection~~The transport block set always contains only one transport block.
3. Transmission Time Interval (TTI). For FDD the HS-DSCH TTI is fixed and equal to 2ms. The HS-DSCH TTI for 3.84 Mcps TDD is 10 ms. For 1.28 Mcps TDD a fixed 5 ms TTI shall apply.
4. Coding parameters:
 - Type of error protection: turbo code rate 1/3.
5. Modulation - dynamic for first transmission and retransmission. ~~Support for QPSK is mandatory in the UE whereas support for 16QAM depends on the UE capability. There shall be mandatory support for QPSK and 16QAM.~~
6. Redundancy version - dynamic.
7. CRC size - fixed size of 24 bits. There is one CRC per TTI, i.e. one CRC per TB set.

6 MAC architecture

6.1 HSDPA HS-DSCH MAC architecture – UE side

This subclause describes the architecture of the MAC and functional split required to support HSDPA HS-DSCH on the UE side.

6.1.1 Overall architecture

Figure 6.1.1-1 shows the overall MAC architecture. ~~In case of HSDPA-t~~The data received on HS-DSCH is mapped to the MAC-c/sh. The MAC-hs is configured via the MAC Control SAP by RRC similar to the MAC-c/sh and MAC-d, to set the parameters in the MAC-hs such as allowed transport format combinations for the HS-DSCH.

The associated Downlink Signalling carries information for support of HS-DSCH while the associated Uplink Signalling carries feedback information.

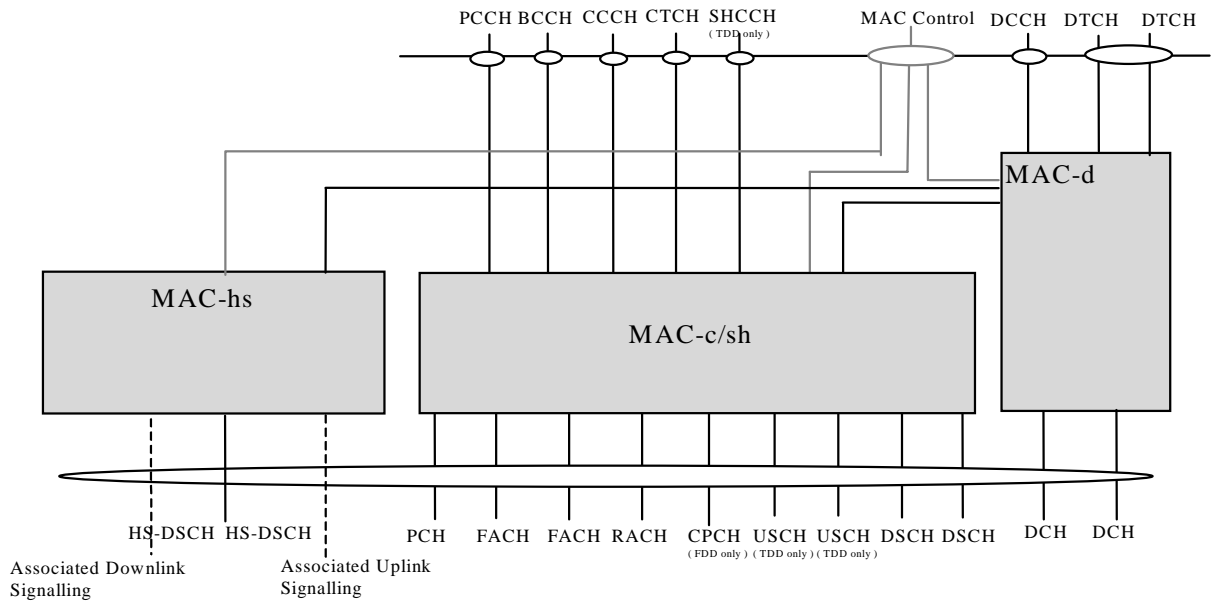
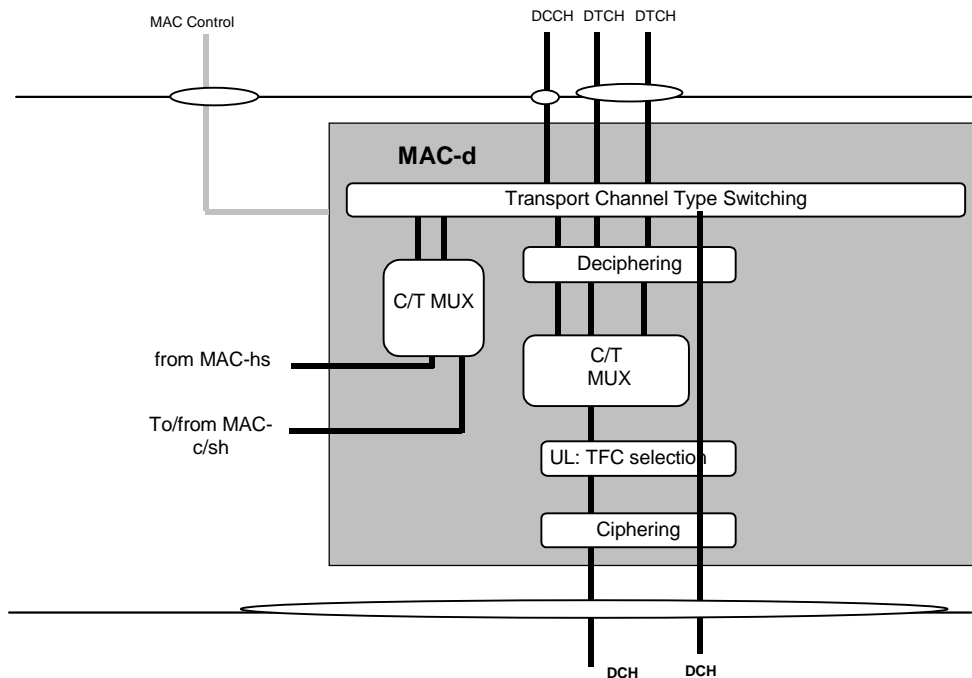

Figure 6.1.1-1: UE side MAC architecture with HSDPA/HS-DSCH

6.1.2 Details of MAC-d

The MAC-d entity is modified with the addition of a link to the MAC-hs entity. The links to MAC-hs and MAC-c/sh cannot be configured simultaneously in one UE.

The mapping between C/T MUX entity in MAC-d and the reordering buffer in MAC-hs is configured by higher layers. One reordering buffer maps to one C/T MUX entity and many reordering buffers can map to the same C/T MUX entity.



Note 1: For DCH, DSCH and HS-DSCH, different scheduling mechanisms apply
 Note 2: Ciphering is performed in MAC-d only for transparent RLC mode

Figure 6.1.2-1: MAC-d architecture

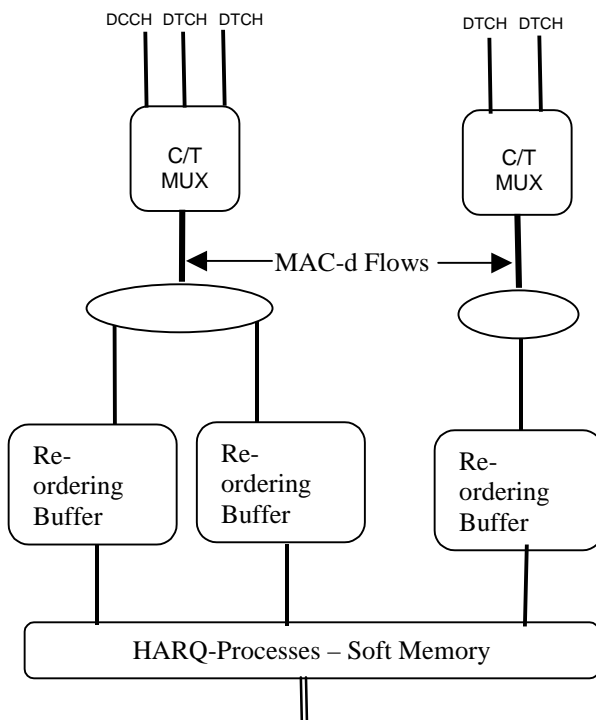

Figure 6.1.2-2: Simplified architecture showing MAC-hs inter-working in UE

6.1.3 Details of MAC-c/sh

The MAC-c/sh on the UE side is not modified for ~~HSDPA~~HS-DSCH.

6.1.4 Details of MAC-hs

The MAC-hs handles the ~~HSDPA~~HS-DSCH specific functions. In the model below the MAC-hs comprises the following entity:

- HARQ:
The HARQ entity is responsible for handling the HARQ protocol. There shall be one HARQ process per HS-DSCH per TTI. The HARQ functional entity handles all the tasks that are required for hybrid ARQ. It is for example responsible for generating ACKs or NACKs. The detailed configuration of the hybrid ARQ protocol is provided by RRC over the MAC-Control SAP.
- Reordering:
The reordering entity organises received data blocks according to the received TSN. Data blocks with consecutive TSNs are delivered to higher layers upon reception. A timer mechanism determines delivery of non-consecutive data blocks to higher layers. There is one reordering entity for each priority class, ~~and MAC identity configured at the UE.~~
- ~~Multiplexing chain inside MAC-hs needs to be completed.~~The following is allowed:
 - One MAC-hs PDU contains only MAC-d PDUs with the same priority, and from the same MAC-d flow;
 - Different MAC-d PDU sizes can be supported in a given MAC-hs PDU.

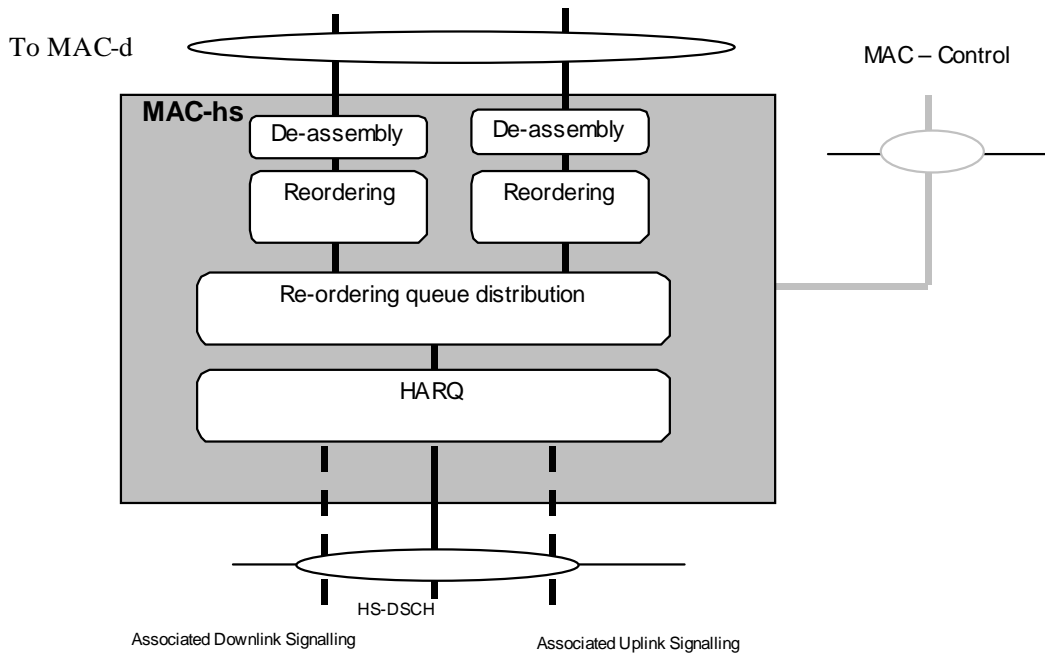

Figure 6.1.4-1: UE side MAC architecture/MAC-hs details

6.2 HSDPA/HS-DSCH MAC architecture – UTRAN side

This subclause describes the **changes that are required** modifications -to the MAC model **with respect to the Release 99 model** to support the features for **HSDPA/HS-DSCH** on the UTRAN side.

6.2.1 Overall architecture

A new MAC functional entity, the MAC-hs, is added to the MAC architecture of Release '99. The MAC-hs is located in the Node B. If an HS-DSCH is assigned to the UE the MAC-hs SDUs, i.e. MAC-d PDUs to be transmitted are transferred from MAC-c/sh to the MAC-hs via the Iub interface in case of Configuration with MAC-c/sh, or from the MAC-d via Iur/Iub in case of Configuration without MAC-c/sh.

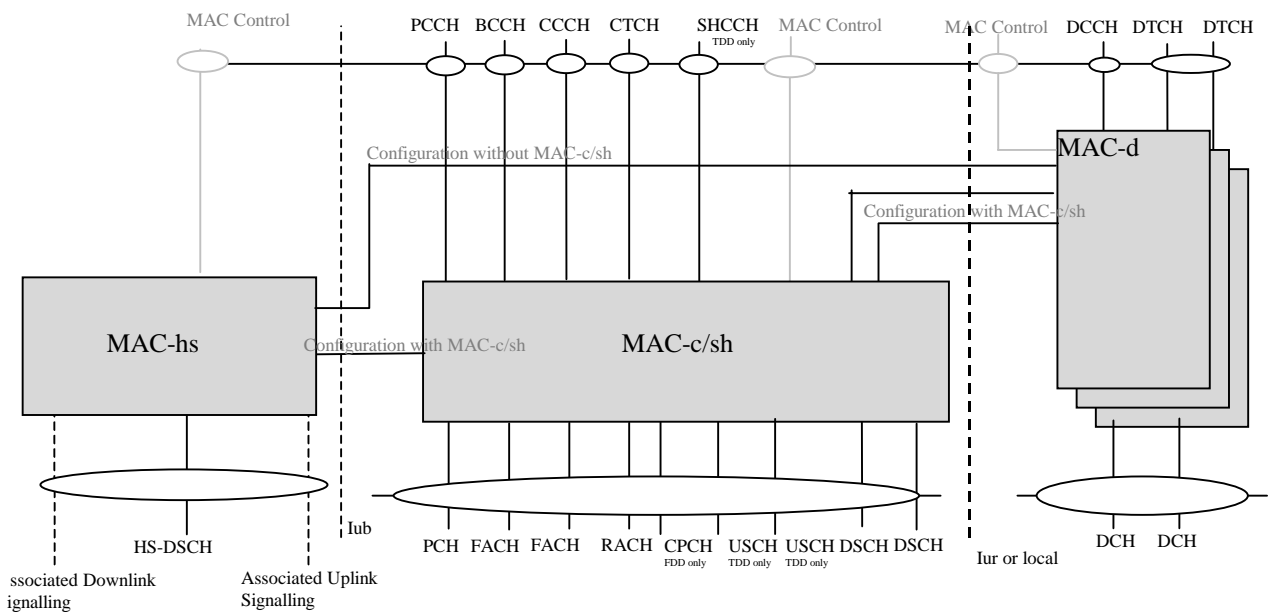

Figure 6.2.1-1: UTRAN side overall MAC architecture

The multiplexing chain for **HSDPA****HS-DSCH** on the UTRAN side is illustrated below:

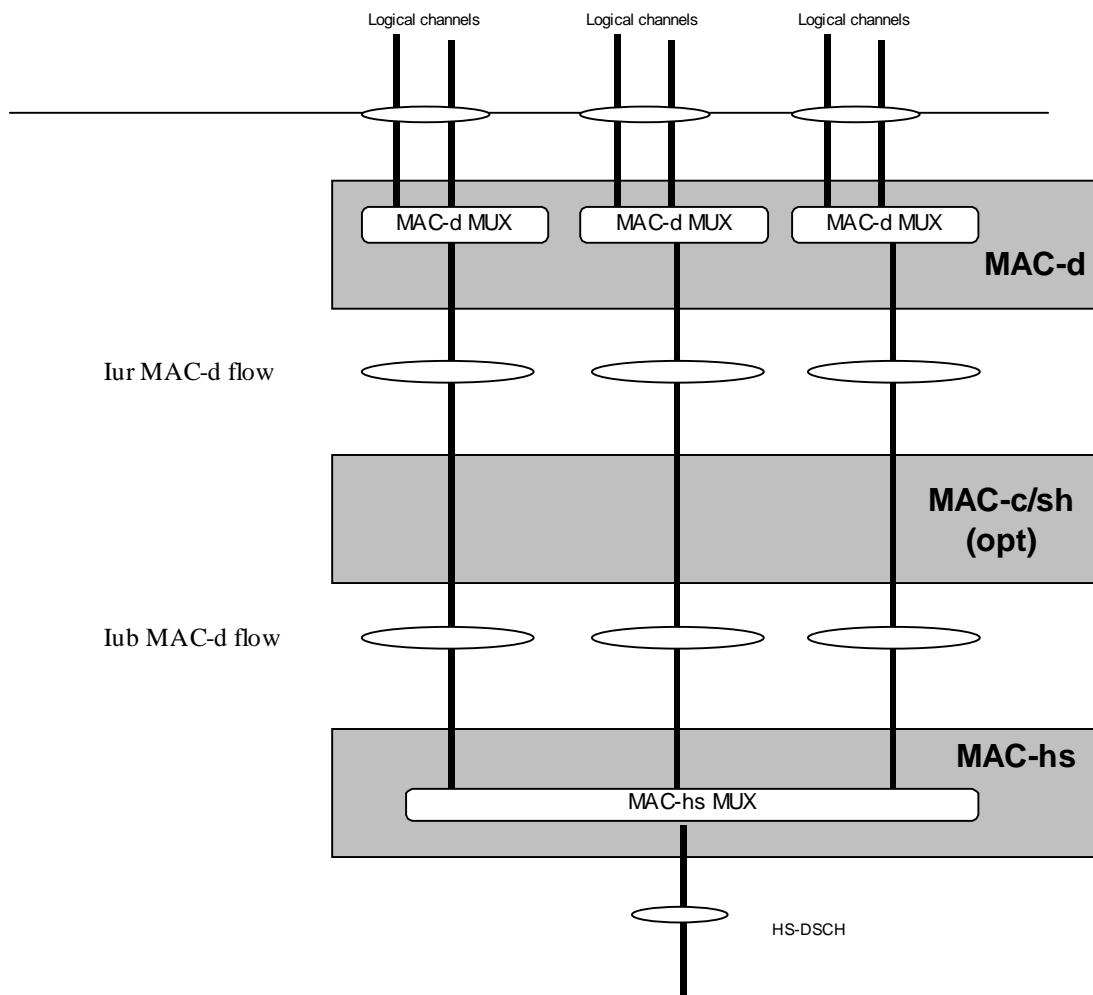

Figure 6.2.1-2: UTRAN side of MAC multiplexing

6.2.2 Details of MAC-c/sh

The data for the HS-DSCH is subject to flow control between the serving and the drift RNC.

A new flow control function is included to support the data transfer between MAC-d and MAC-hs.

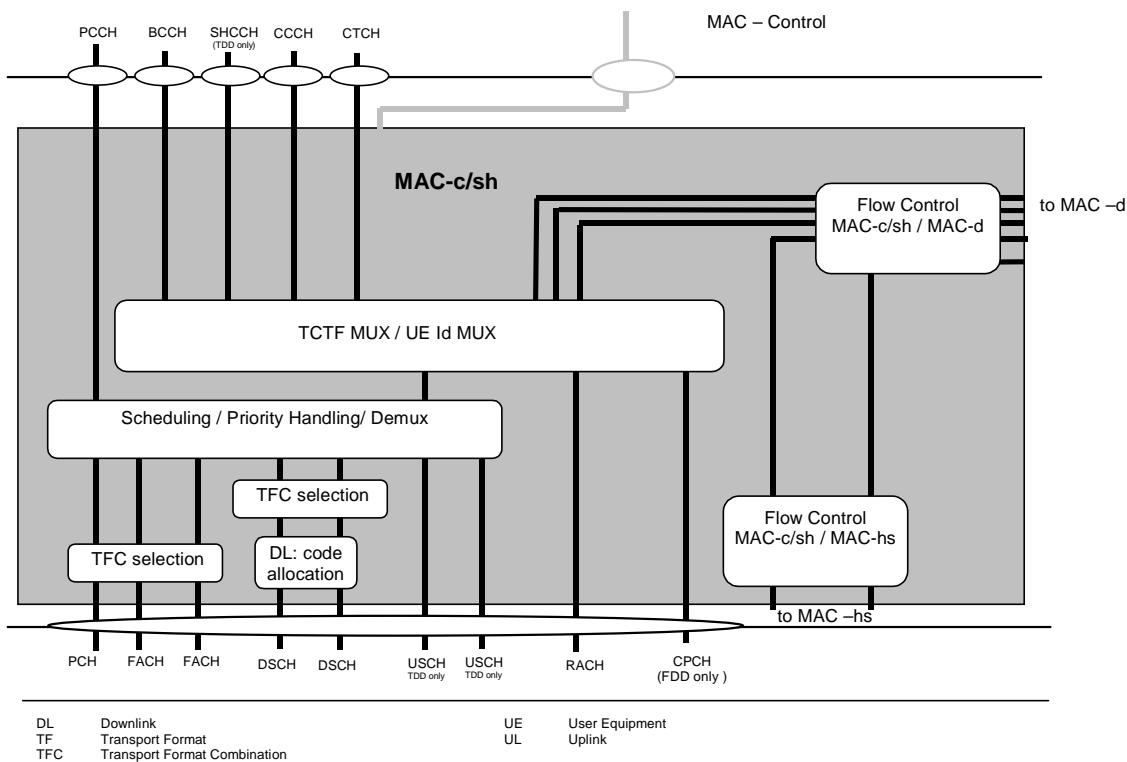

Figure 6.2.2-1: UTRAN side MAC architecture/MAC-c/sh details

6.2.3 Details of MAC-hs

The MAC-hs is responsible for handling the data transmitted on the HS-DSCH. Furthermore it is **its responsibility responsible for the management of** the physical resources allocated to **HSDPA HS-DSCH**. MAC-hs receives configuration parameters from the RRC layer via the MAC-Control SAP. There shall be priority handling per MAC-d PDU in the MAC-hs. The MAC-hs is comprised of four different functional entities:

- Flow Control:

This is the companion flow control function to the flow control function in the MAC-c/sh in case of Configuration with MAC-c/sh and MAC-d in case of Configuration without MAC-c/sh. Both entities together provide a controlled data flow between the MAC-c/sh and the MAC-hs (Configuration with MAC-c/sh) or the MAC-d and MAC-hs (Configuration without MAC-c/sh) taking the transmission capabilities of the air interface into account in a dynamic manner. This function is intended to limit layer 2 signalling latency and reduce discarded and retransmitted data as a result of HS-DSCH congestion. Flow control is provided independently **by per** priority class for each MAC-d flow.
- Scheduling/Priority Handling:

This function manages HS-DSCH resources between HARQ entities and data flows according to their priority class. Based on status reports from associated uplink signalling either new transmission or retransmission is determined. Further it sets the priority class identifier and TSN for each new data block being serviced. To maintain proper transmission priority a new transmission can be initiated on a HARQ process at any time. The TSN is unique to each priority class within a HS-DSCH, and is incremented for each new data block. It is not permitted to schedule new transmissions, including retransmissions originating in the RLC layer, within the same TTI, along with retransmissions originating from the HARQ layer.
- HARQ:

One HARQ entity handles the hybrid ARQ functionality for one user. One HARQ entity is capable of supporting multiple instances (HARQ process) of stop and wait HARQ protocols. There shall be one HARQ process per TTI.
- TFC selection:

Selection of an appropriate transport format and resource combination for the data to be transmitted on HS-DSCH.

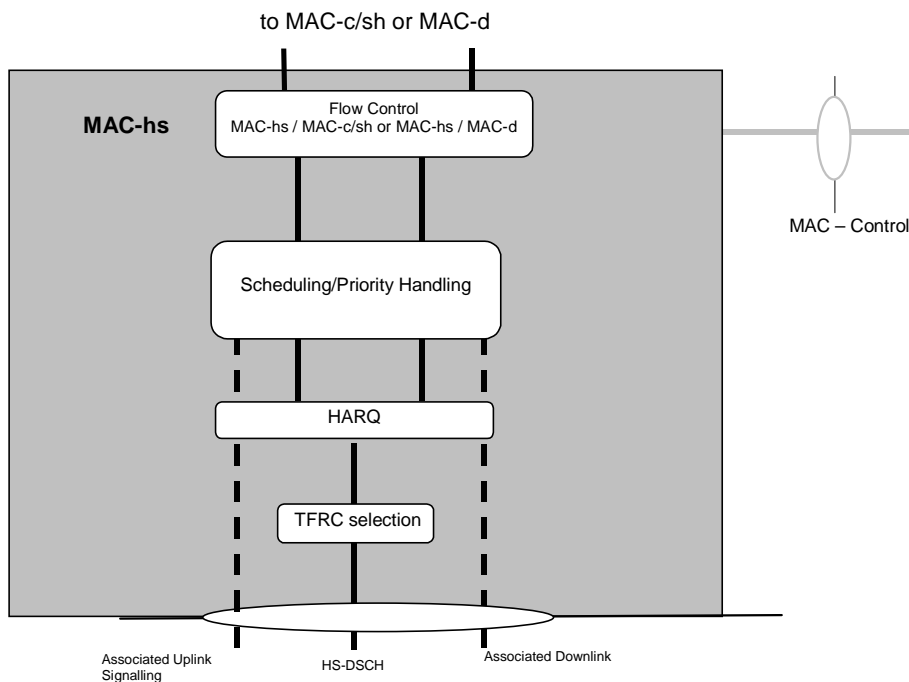

Figure 6.2.3-1: UTRAN side MAC architecture/MAC-hs details

7 HARQ protocol

The HARQ protocol is based on an asynchronous downlink and synchronous uplink scheme. The ARQ combining scheme is based on Incremental redundancy. Chase Combining is considered to be a particular case of Incremental Redundancy. The UE soft memory capability shall be defined according to the needs for Chase combining. The soft memory is partitioned across the HARQ processes in a semi-static fashion through upper layer signalling. The UTRAN should take into account the UE soft memory capability when configuring the different transport formats (including possibly multiple redundancy versions for the same effective code rate) and when selecting transport formats for transmission and retransmission.

7.1 Signalling

7.1.1 Uplink

In the uplink, a report is used indicating either ACK (positive acknowledgement) or NACK (negative acknowledgement).

7.1.2 Downlink

7.1.2.1 Shared control channel signalling

The following HARQ protocol parameters are carried on the HS-SCCH:

- HARQ process identifier:
 - Every HARQ process is assigned an identifier, which is used to couple the processes in the transmitter and the receiver.
- New data indicator:
 - It is used to distinguish between data blocks. It is specific to the HARQ process. It is incremented for each new data block.

7.1.2.2 In-band signalling on HS-DSCH

The following parameters are signalled in-band in the MAC-hs header to support in-sequence delivery and priority handling at the UE. These parameters are protected by the same CRC as the Data block.

- Priority class identifier:
 - It is used to distinguish different priority classes in order to differentiate between logical channels multiplexed in the same transport channel.
- Transmission sequence number:
 - It is incremented for each new data block within a priority class. It is used for reordering to support in-sequence delivery.

7.2 ~~Void Network operation~~

~~The following are the functions of the various functional entities at the network in support of the HARQ protocol.~~

~~7.2.1 Scheduler~~

~~The scheduler performs the following functions:~~

- ~~— Schedules all UEs within a cell.~~
- ~~— Services priority class queues:

 - ~~— The scheduler receives MAC-hs SDUs based on information from the Iub frame protocol. One UE may be associated with one or more Iub logical flows. Each Iub logical flow contains HS-DSCH MAC-d PDUs for one priority class.~~
 - ~~— There is a delay attribute associated with each priority class queue. The delay attribute is provided from RNC to Node B (e.g., signalled in the control plane by NBAP).~~
 - ~~— Information about the available bit rate for each priority class queue may be provided from Node B to RNC.~~~~
- ~~— Determines the HARQ Entity and the queue to be served.~~
- ~~— Schedules new transmissions and retransmissions:

 - ~~— Based on the status reports from HARQ Processes the scheduler determines either new transmission or retransmission. A new transmission can be initiated on an HARQ process at any time.~~~~

~~7.2.2 HARQ entity (one per UE)~~

~~There is one HARQ entity per UE. It performs the following functions:~~

- ~~— Priority class identifier setting:

 - ~~— It sets the priority class identifier based on priority class of the queue being serviced.~~~~
- ~~— Transmission sequence number setting:

 - ~~— The TSN is incremented for each new data block within the same HS-DSCH and priority class. TSN is initiated at value 0.~~~~
- ~~— HARQ process identifier setting:

 - ~~— The HARQ process to service the request is determined and the HARQ process identifier is set accordingly.~~~~

~~7.2.3 HARQ process~~

~~The following are the functions of the HARQ process:~~

- ~~New Data Indicator setting:~~

- ~~The New data indicator is incremented each time when there is new data for this HARQ process.~~

- ~~Processes ACK/NACK from the receiver:~~

- ~~The status report from the UE is passed to the scheduler.~~

7.3 ~~Void~~UE operation

The UE operation in support of the HARQ protocol is split among the following three functional units with their associated functions:

7.3.1 HARQ entity

There is one HARQ entity at the UE performing the following function:

- ~~Processes HARQ process identifiers:~~

- ~~It allocates received data blocks to different HARQ processes based on the HARQ process identifiers.~~

7.3.2 HARQ process

The HARQ process at the UE performs the following functions:

- ~~New Data Indicator processing:~~

- ~~If the New Data Indicator has been incremented compared to the value in the previous transmission, if any, the data currently in the soft buffer can be replaced with the received data block.~~

- ~~If the New Data Indicator is identical to the value used in the previous transmission, the received data is combined with the data currently in the soft buffer.~~

- ~~Error detection result processing:~~

- ~~The physical layer decodes the data in the soft buffer and checks for errors.~~

- ~~If no error was detected, the decoded data is forwarded to the reordering entity and an ACK is generated.~~

- ~~If an error was detected a NACK is generated.~~

- ~~Status report transmission:~~

- ~~The status report is scheduled for transmission based on predetermined configuration.~~

- ~~Priority class identifier processing:~~

- ~~Received data is arranged in queues based on priority class identifiers.~~

7.3.3 Reordering entity

There is one re-ordering entity for each priority class and transport channel configured at the UE. It performs the following functions:

- ~~Reordering of received data based on transmission sequence numbers:~~

- ~~A received data block is inserted to its appropriate position in the queue according to the TSN.~~

- ~~Forwarding data to higher layer:~~

- ~~If the received data block is the next to be delivered to higher layer, all data blocks with consecutive TSNs up to the first not received data block are delivered to higher layer.~~

- ~~A timer mechanism determines the delivery of non consecutive data blocks to higher layer.~~

~~Stall avoidance mechanisms in the reordering buffer based on upper layer configured timers and window based schemes can be configured.~~

~~7.3.3.1 Timer-based mechanism~~

~~Timer T1 controls the stall avoidance in the UE reordering buffer. The value of T1 is configured by upper layers.~~

~~If no timer T1 is active:~~

- ~~— the timer T1 shall be started when a data block with TSN=SN is correctly received but cannot be delivered to higher layer due to that a data block with lower TSN is missing.~~

~~If a timer T1 is already active:~~

- ~~— no additional timer shall be started, i.e. only one timer T1 may be active at a given time.~~

~~The timer T1 shall be stopped if:~~

- ~~— the data block for which the timer was started can be delivered to higher layer before the timer expires.~~

~~When the timer T1 expires:~~

- ~~— all data blocks up to and including TSN-1 shall be removed from the reordering buffer;~~
- ~~— all data blocks up to the first missing data block shall be delivered to higher layer.~~

~~When the timer T1 is stopped or expires, and there still exist some received data blocks that cannot be delivered to higher layer:~~

- ~~— timer T1 is started for the data block with lowest TSN among those data blocks that cannot be delivered.~~

~~7.3.3.2 Window-based mechanism~~

~~Additional mechanisms can be used in combination with the timer based mechanism, in order to account for the module nature of the TSN. Details can be found in [2].~~

7.4 Error handling

The most frequent error cases to be handled are the following:

- NACK is detected as an ACK. The NW starts afresh with new data in the HARQ process. The data block is discarded in the NW and lost. Retransmission is left up to higher layers.
- ACK is detected as a NACK: If the network retransmits the data block, the UE will re-send an ACK to the network. If in this case the transmitter at the network sends an abort indicator by incrementing the New Packet Indicator, the receiver at the UE will continue to process the data block as in the normal case.
- ~~— [A threshold to detect lost status message is up to NW implementation. If detection is possible, better performance is achieved by defaulting to a NACK.]~~
- If a CRC error on the HS-SCCH is detected, UE receives no data and sends no status report. If the absence of the status report is detected, NW can retransmit the block.

8 Signalling parameters

[Claude, I have managed to mess up the style in the above....TAB spacing for H1 style above seems incorrect – cannot seem to revive it!](#)

8.1 Downlink signalling parameters

8.1.1 UE identification

This identifies the UE (or UEs) for which data is transmitted in the corresponding HS-DSCH TTI. The UE identity is implicitly carried on the HS-SCCH through inclusion in the CRC calculation.

8.1.2 Transport format Block Sizes

This defines what transport format (Transport Block Set Size) is used in the corresponding HS-DSCH TTI.

This defines what transport block size is used in the corresponding HS-DSCH TTI. The signalled parameter is an index to a pre-defined set of available transport block sizes.

8.1.3 Channelisation codes (FDD only)

This identifies to the UE (or UEs) the codes it (they) should receive and decode.

8.1.4 HS-PDSCH configuration (TDD only)

This identifies to a UE (or UEs) the timeslots and codes it (they) should receive and decode. Additionally, which transport formats are applied on HS-DSCH is also signalled. An identical set of channelisation codes is used in each of the identified timeslots.

8.1.5 HARQ information

Details of signalling parameters for the HARQ Protocol can be found in subclause 7.1.2. In addition, to support the Incremental Redundancy combining scheme, the Redundancy version is also signalled on the HS-SCCH.

8.1.6 Measurement feedback rate (FDD only)

This identifies the feedback rate for downlink quality measurement. This information may be sent at a much lower rate than the other parameters described in this subclause.

8.1.7 HS-PDSCH power offset

Default power offset between HS-DSCH code channel and P-CPICH (or S-CPICH in case beamforming with S-CPICH is used).

8.1.8 BLER threshold Void

BLER value that UE uses for selecting the TFRC provided as a channel quality indicator.

8.1.9 Padding indicator Void

In order to account for possible limited granularity in the Transport Block Set Size a padding indicator along with number of padding blocks is indicated in the MAC-hs header.

The following table identifies the downlink signalling parameters.

Table 1: Downlink Signalling Parameters

Parameter	Location	Length in bits (FDD)	Length in bits (3.84 Mcps TDD)	Length in bits (1.28 Mcps TDD)
HARQ Parameters				
Process Identity	HS-SCCH	3	3	3
New Data Indicator	HS-SCCH	[1]	[1]	[1]
Redundancy Version	HS-SCCH	[3]	[2]	[2]
Priority Class Indicator	HS-PDSCH	3	3	3
TSN	HS-PDSCH	6	6	6
Padding Block Indicator and TB count	HS-PDSCH			
Transport Format and Resource Indication Parameters				
Resource Allocation	HS-SCCH	7	24	13
Modulation	HS-SCCH	4	4	4
Transport Block Set Size	HS-SCCH	6	9	6
Other Parameters				
Measurement Feedback Rate	Upper Layer signalling-on-set-up		none	none
Power Offset	Upper Layer signalling-on-set-up		none	none
BLER _{threshold}	Upper Layer signalling-on-set-up			

8.1.10 HS-SCCH Cyclic Sequence Number (HCSN) (TDD only)

A cyclic counter that is incremented each time a HS-SCCH transmission is sent to a given UE. Separate counters are maintained for each UE. The counter is used by the UE to estimate the BLER on the HS-SCCH for the purposes of closed loop power control.

8.2 Uplink signalling parameters

8.2.1 ACK/NACK

A one-bit indication is used by the HARQ protocol to indicate a successful/unsuccessful transmission on the HS-DSCH.

8.2.2 Measurement report

In FDD, the transmission rate of the measurement report to the network is configured by upper layer signalling.

Measurement feedback information contains channel quality indicator that may be used to select transport format and resource by HS-DSCH serving Node-B. For FDD, the transmission rate of the measurement report to the network is configured by higher layer signalling. For TDD, a measurement report is associated with each HS-SCCH transmission.

The following table identifies the uplink signalling parameters.

Table 2: Uplink Signalling Parameters

Parameter	Channel Location	Length in bits (FDD)	Length in bits (3.84 Mcps TDD)	Length in bits (1.28 Mcps TDD)
Status Indicator (ACK/NACK)	DPCCH-HS	4	4	4
Channel Quality Indicator	DPCCH-HS	[5]	40	7

9 Mobility procedures

While in CELL_DCH state, the UE may be allocated one or more HS-PDSCH(s), allowing it to receive data on the HS-DSCH(s).

Mobile evaluated hard-handover and soft-handover mechanisms provide the RRC connection mobility in CELL_DCH state. The mobility procedures are affected by the fact that the HS-PDSCH allocation for a given UE belongs to only one of the radio links assigned to the UE, the *serving HS-DSCH radio link*. The cell associated with the serving HS-DSCH radio link is defined as the *serving HS-DSCH cell*.

A *serving HS-DSCH cell change* facilitates the transfer of the role of serving HS-DSCH radio link from one radio link belonging to the source HS-DSCH cell to a radio link belonging to the target HS-DSCH cell.

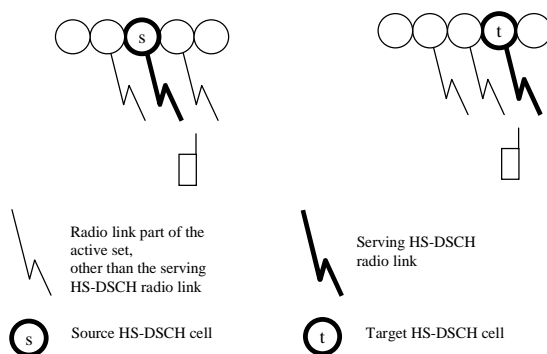

Figure 9-1: Serving HS-DSCH cell change

The serving HS-DSCH cell change may be further categorised in regards to whether the decision of the target HS-DSCH cell is made by the UE or by the network. In Release 5, only network controlled serving HS-DSCH cell changes shall be supported.

In case of a *network-controlled serving HS-DSCH cell change* the network makes the decision of the target HS-DSCH cell, and the decision could be based on UE measurement reports and other information available in the network. A network controlled HS-DSCH cell change is performed as an RRC layer signalling procedure and is based on the existing handover procedures in CELL_DCH state.

9.1 Serving HS-DSCH cell change

NOTE: This sub-clause needs to be reviewed.

With regard to the way a serving HS-DSCH cell change is performed with respect to the dedicated physical channel configuration, the following categories exist:

1. Serving HS-DSCH cell change while keeping the dedicated physical channel configuration and the active set;
2. Serving HS-DSCH cell change in combination with an establishment, release and/or reconfiguration of dedicated physical channels (note: this may by definition imply an update of the active set);
3. Serving HS-DSCH cell change in combination with active set update in soft handover.

With respect to synchronisation between UE and UTRAN as to when transmission and reception is stopped and restarted, two possibilities for a serving HS-DSCH cell change exist:

1. Synchronised serving HS-DSCH cell change: Start and stop of HS-DSCH transmission and reception is performed at a certain time typically selected by the network;
2. Unsynchronised serving HS-DSCH cell change: Start and stop of HS-DSCH transmission and reception is performed "as soon as possible" (stated by UE performance requirements) at either side.

The serving HS-DSCH cell change may also be categorised with respect to the serving HS-DSCH Node B:

1. Intra-Node B serving HS-DSCH cell change: The source and target HS-DSCH cells are both controlled by the same Node B. The serving HS-DSCH Node B is not changed.
2. Inter-Node B serving HS-DSCH cell change: The Node B controlling the target HS-DSCH cell is different from the Node B controlling the source HS-DSCH cell.

The cell-Node B relations shall remain transparent for the UE and the UE should therefore shall not be aware of whether the serving HS-DSCH cell change procedure is of a intra-Node B or inter-Node B nature.

At an Inter-Node B serving HS-DSCH cell change, a *serving HS-DSCH Node B relocation* needs to be performed at the UTRAN. Serving HS-DSCH Node B relocation and serving HS-DSCH cell change are two separate procedures, even if serving HS-DSCH Node B relocation cannot be performed without a serving HS-DSCH cell change (but the other way is possible).

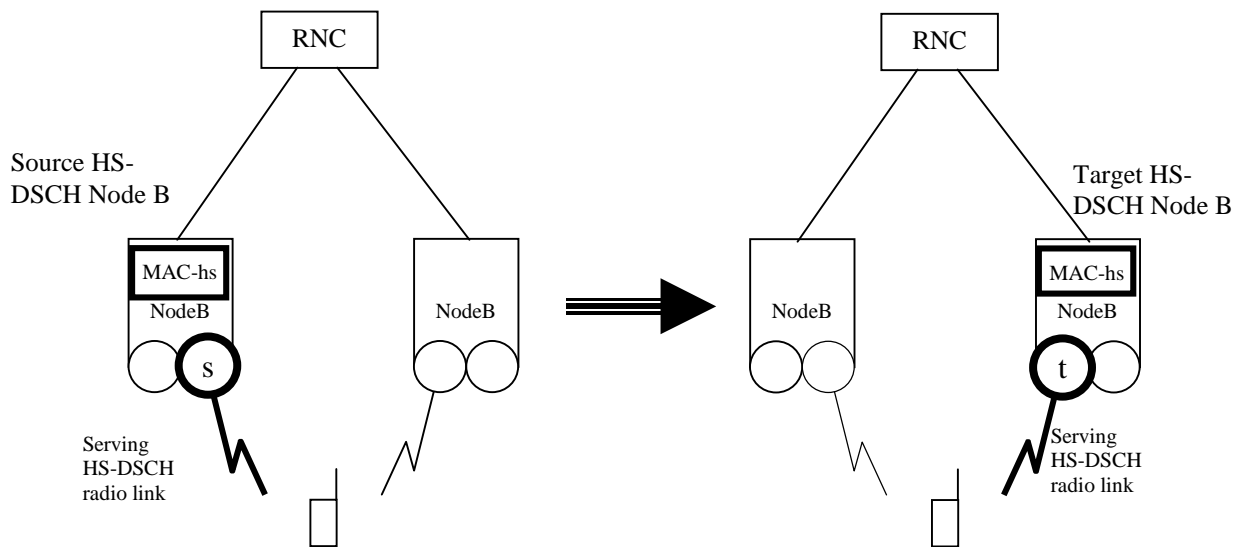

Figure 9.1-1: Inter-Node B serving HS-DSCH cell change combined with serving HS-DSCH Node B relocation

During a serving HS-DSCH Node B relocation, the HARQ entities located in the source HS-DSCH Node B belonging to the specific UE are deleted and new HARQ entities in the target HS-DSCH Node B are established. Different CRNCs may control the source and target HS-DSCH Node B.

9.2 Serving HS-DSCH cell change mechanisms

In the case of AM RLC mode, the polling function either pre- or post- HS-DSCH cell change can be utilised to obtain the status of the data transmission to the UE at the RLC level. In the case of UM RLC mode, the need for relocating the PDUs not transmitted to the UE, is FFS.

NOTE: Additional mechanisms would need to be defined in the relevant TSG-RAN WG3 specifications to indicate to the Node B to stop transmission to the UE on a decision to execute an HS-DSCH cell change.

9.3 Intra-Node B synchronised serving HS-DSCH cell change

Figure 9.3-1 illustrates an intra-Node B serving HS-DSCH cell change while keeping the dedicated physical channel configuration and the active set, using the Physical channel reconfiguration procedure. The transition from source to target HS-DSCH cell is performed synchronised, i.e. at a given activation time.

In this example, the UE transmits a MEASUREMENT REPORT message containing intra-frequency measurement results, here assumed to be triggered by the event 1D "change of best cell". When the SRNC has performed the

handover decision, the Node B is prepared for the serving HS-DSCH cell change at an activation time indicated with CPHY-RL-Commit-REQ primitive. The SRNC then sends a PHYSICAL CHANNEL RECONFIGURATION message, which indicates the target HS-DSCH cell and the activation time to the UE. Since the same Node B controls both the source and target HS-DSCH cells we assume there is no need to reset the MAC-hs entities. When the UE has completed the serving HS-DSCH cell change it transmits a PHYSICAL CHANNEL RECONFIGURATION COMPLETE message to the network.

In this example it is assumed that HS-DSCH transport channel and radio bearer parameters do not change. If transport channel or radio bearer parameters shall be changed, the serving HS-DSCH cell change would need to be executed by a Transport channel reconfiguration procedure or a Radio bearer reconfiguration procedure, respectively.

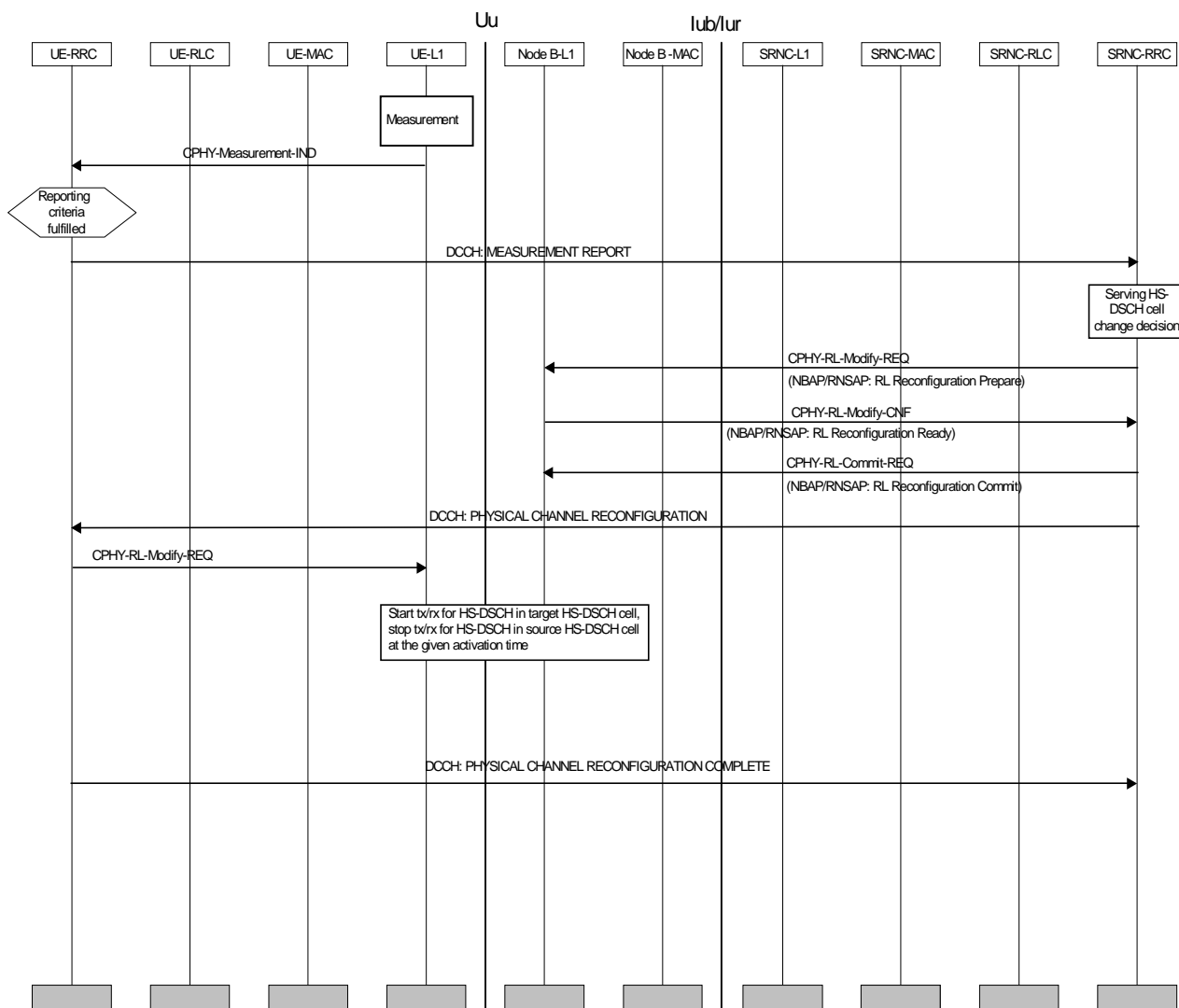

Figure 9.3-1: Intra-Node B synchronised serving HS-DSCH cell change

9.4 Inter-Node B synchronised serving HS-DSCH cell change during hard handover

Figure 9.4-1 illustrates a synchronised inter-Node B serving HS-DSCH cell change in combination with hard handover. The reconfiguration is performed in two steps within UTRAN. On the radio interface only a single RRC procedure is used.

Here we assume the UE transmits a MEASUREMENT REPORT message containing intra-frequency measurement results, triggered by the event 1D "change of best cell". The SRNC determines the need for hard handover based on

9.5 Inter-Node B synchronised serving HS-DSCH cell change after active set update (radio link addition)

Figure 9.5-1 illustrates an inter-Node B serving HS-DSCH cell change performed subsequent to an active set update. In this example it is assumed that a new radio link is added which belongs to a target Node B different from the source Node B. The cell which is added to the active set is assumed to become the serving HS-DSCH cell in the second step. This combined procedure is comprised of an ordinary Active Set Update procedure in the first step and a synchronised serving HS-DSCH cell change in the second step.

We assume the UE transmits a MEASUREMENT REPORT message containing intra-frequency measurement results. The SRNC determines the need for the combined radio link addition and serving HS-DSCH cell change based on received measurement reports and/or load control algorithms (measurements may be performed in compressed mode for FDD).

As the first step, the SRNC establishes the new radio link in the target Node B for the dedicated physical channels and transmits an ACTIVE SET UPDATE message to the UE. The ACTIVE SET UPDATE message includes the necessary information for establishment of the dedicated physical channels in the added radio link (but not the HS-PDSCH). When the UE has added the new radio link it returns an ACTIVE SET UPDATE COMPLETE message.

The SRNC will now carry on with the next step of the procedure, which is the serving HS-DSCH cell change. The target HS-DSCH cell is the newly added radio link, so far only including dedicated physical channels. For the synchronised serving HS-DSCH cell change, both the source and target Node Bs are first prepared for execution of the handover at the activation time indicated with CPHY-RL-Commit-REQ primitive.

The SRNC then sends a TRANSPORT CHANNEL RECONFIGURATION message, which indicates the target HS-DSCH cell and the activation time to the UE. The message may also include a configuration of transport channel related parameters for the target HS-DSCH cell, including an indication to reset the MAC-hs entity.

Since source and target HS-DSCH cell are controlled by different Node Bs, MAC-hs in source and target Node B need to be released and setup, respectively, which is assumed to be done with CMAC-HS-Release-REQ and CMAC-HS-Setup-REQ primitives. These MAC-hs control primitives are assumed to be carried on the same NBAP/RNSAP messages, which carry the CPHY-RL-Reconfig-REQ primitives. Execution of release and setup of MAC-hs entities shall also be performed at the indicated activation time.

When the UE has completed the serving HS-DSCH cell change it returns a TRANSPORT CHANNEL RECONFIGURATION message to the network.

Annex A (informative): Evaluation criteria

The following considerations should be taken into account in the evaluation of the different techniques proposed for [HSDPAHS-DSCH](#):

1. The focus shall be on the streaming, interactive and background services. It should be noted that it might not be possible to simultaneously optimise the performance of [HSDPAHS-DSCH](#) for all of the above traffic classes.
2. System performance improvement shall be obtained with concomitant reduction in delay of service.
3. Priority shall be given to urban environments and then to indoor deployments. The techniques shall not be limited to these environments however.
4. The techniques accepted shall be optimised at speeds typical of urban environments but techniques should apply at other speeds also. Full mobility shall be supported, i.e., mobility should be supported for high-speed cases also, but optimisation should be for low-speed to medium-speed scenarios.
5. Features or group of features considered should demonstrate significant incremental gain.
6. Features accepted shall provide the benefit at reasonable cost to the operators. The value added per feature should be considered in the evaluation.
7. The techniques should be compatible with advanced antenna and receiver techniques.
8. The techniques should take into account the impact on Release '99 networks both from a protocol and hardware perspective.
9. The choice of techniques (such as HARQ) shall take into account UE processing time and memory requirements.
10. The UE complexity shall be minimised for a given level of system performance.
11. An evolutionary philosophy shall be adopted as opposed to a revolutionary one in adopting new techniques and architectures.

Annex B (informative): Change history

Change history							
Date	TSG #	TSG Doc.	CR	Rev	Subject/Comment	Old	New
09/2001	RP-13	RP-010643	-		Approved at TSG-RAN #13 and placed under Change Control	-	5.0.0
12/2001	RP-14	RP-010774	001		Update to HSDPA Stage 2	5.0.0	5.1.0
03/2002	RP-15	RP-020093	002		HSDPA Updates	5.1.0	5.2.0

3GPP TSG-RAN WG2 Meeting #33
Sophia Antipolis, France, 12th-15th November 2002

Tdoc # R2-022705

<small>CR-Form-v7</small>
<h2 style="margin: 0;">CHANGE REQUEST</h2>
25.308 CR 004 # rev - # Current version: 5.2.0

For **HELP** on using this form, see bottom of this page or look at the pop-up text over the # symbols.

Proposed change affects: UICC apps# ME Radio Access Network Core Network

Title:	#	Generation of RLC Status Reports to coordinate with MAC-hs reset
Source:	#	InterDigital
Work item code:	#	HSDPA-L23
	Date: #	Sep 27, 2002
Category:	#	B
		Use <u>one</u> of the following categories: F (correction) A (corresponds to a correction in an earlier release) B (addition of feature), C (functional modification of feature) D (editorial modification) Detailed explanations of the above categories can be found in 3GPP TR 21.900 .
	Release: #	REL-5
		Use <u>one</u> of the following releases: 2 (GSM Phase 2) R96 (Release 1996) R97 (Release 1997) R98 (Release 1998) R99 (Release 1999) Rel-4 (Release 4) Rel-5 (Release 5) Rel-6 (Release 6)

Reason for change:	#	UTRAN generates MAC-hs reset upon Node-B serving HS-DSCH cell changes. It was agreed in RAN2#31 that efficient recovery of source Node-B data is achieved with UE automatical generation of RLC Status Reports.
Summary of change:	#	If the IE "MAC-hs reset indicator" is present, the UE resets the MAC-hs entity and RLC Status Reports should be generated.
Consequences if not approved:	#	Unnecessary delay in recovery of data lost in the source Node-B following handovers.

Clauses affected:	#	9.4, 9.5.								
Other specs affected:	#	<table border="1" style="display: inline-table; vertical-align: middle;"> <tr> <td style="width: 20px; text-align: center;">Y</td> <td style="width: 20px; text-align: center;">N</td> </tr> <tr> <td style="text-align: center;">X</td> <td style="text-align: center;"></td> </tr> <tr> <td style="text-align: center;"></td> <td style="text-align: center;">X</td> </tr> <tr> <td style="text-align: center;"></td> <td style="text-align: center;">X</td> </tr> </table> Other core specifications # 25.321 CR 137, 25.322 CR 210. Test specifications O&M Specifications	Y	N	X			X		X
Y	N									
X										
	X									
	X									
Other comments:	#									

How to create CRs using this form:

Comprehensive information and tips about how to create CRs can be found at <http://www.3gpp.org/specs/CR.htm>. Below is a brief summary:

- 1) Fill out the above form. The symbols above marked # contain pop-up help information about the field that they are closest to.
- 2) Obtain the latest version for the release of the specification to which the change is proposed. Use the MS Word "revision marks" feature (also known as "track changes") when making the changes. All 3GPP specifications can be

downloaded from the 3GPP server under <ftp://ftp.3gpp.org/specs/> For the latest version, look for the directory name with the latest date e.g. 2001-03 contains the specifications resulting from the March 2001 TSG meetings.

3) With "track changes" disabled, paste the entire CR form (use CTRL-A to select it) into the specification just in front of the clause containing the first piece of changed text. Delete those parts of the specification which are not relevant to the change request.

9.4 Inter-Node B synchronised serving HS-DSCH cell change during hard handover

Figure 9.4-1 illustrates a synchronised inter-Node B serving HS-DSCH cell change in combination with hard handover. The reconfiguration is performed in two steps within UTRAN. On the radio interface only a single RRC procedure is used.

Here we assume the UE transmits a MEASUREMENT REPORT message containing intra-frequency measurement results, triggered by the event 1D "change of best cell". The SRNC determines the need for hard handover based on received measurement reports and/or load control algorithms (measurements may be performed in compressed mode for FDD).

In the first step, the SRNC establishes a new radio link in the target Node B. In the second step this newly created radio link is prepared for a synchronised reconfiguration to be executed at a given activation time indicated in the CPHY-RL-Commit-REQ primitive. After the first step, the target Node B starts transmission and reception on dedicated channels. At the indicated activation time, transmission of HS-DSCH is started in the target HS-DSCH Node B and stopped in the source HS-DSCH Node B.

The SRNC then sends a TRANSPORT CHANNEL RECONFIGURATION message on the old configuration. This message indicates the configuration after handover, both for DCH and HS-DSCH. The TRANSPORT CHANNEL RECONFIGURATION message includes a flag indicating that the MAC-sh entity in the UE shall be reset. The message also includes an update of transport channel related parameters for the HS-DSCH in the target HS-DSCH cell.

The UE terminates transmission and reception on the old radio link at the activation time indicated in the TRANSPORT CHANNEL RECONFIGURATION message, and configures its physical layer to begin reception on the new radio link. After L1 synchronisation has been established, the UE sends a TRANSPORT CHANNEL RECONFIGURATION COMPLETE message. The SRNC then terminates reception and transmission on the old radio link for dedicated channels and releases all resources allocated to the considered UE.

Note that in this inter-Node B handover example, RLC for transmission/reception on HS-DSCH is stopped at both the UTRAN and UE sides prior to reconfiguration and continued when the reconfiguration is completed. It is furthermore assumed in this example that the TRANSPORT CHANNEL RECONFIGURATION message indicates to the UE that the MAC-hs entity should be reset and a status report for each RLC entity associated with the HS-DSCH should be generated. -A reset of the UE MAC-hs entity however does not require to flush the reordering buffers but to deliver the content to higher layers.

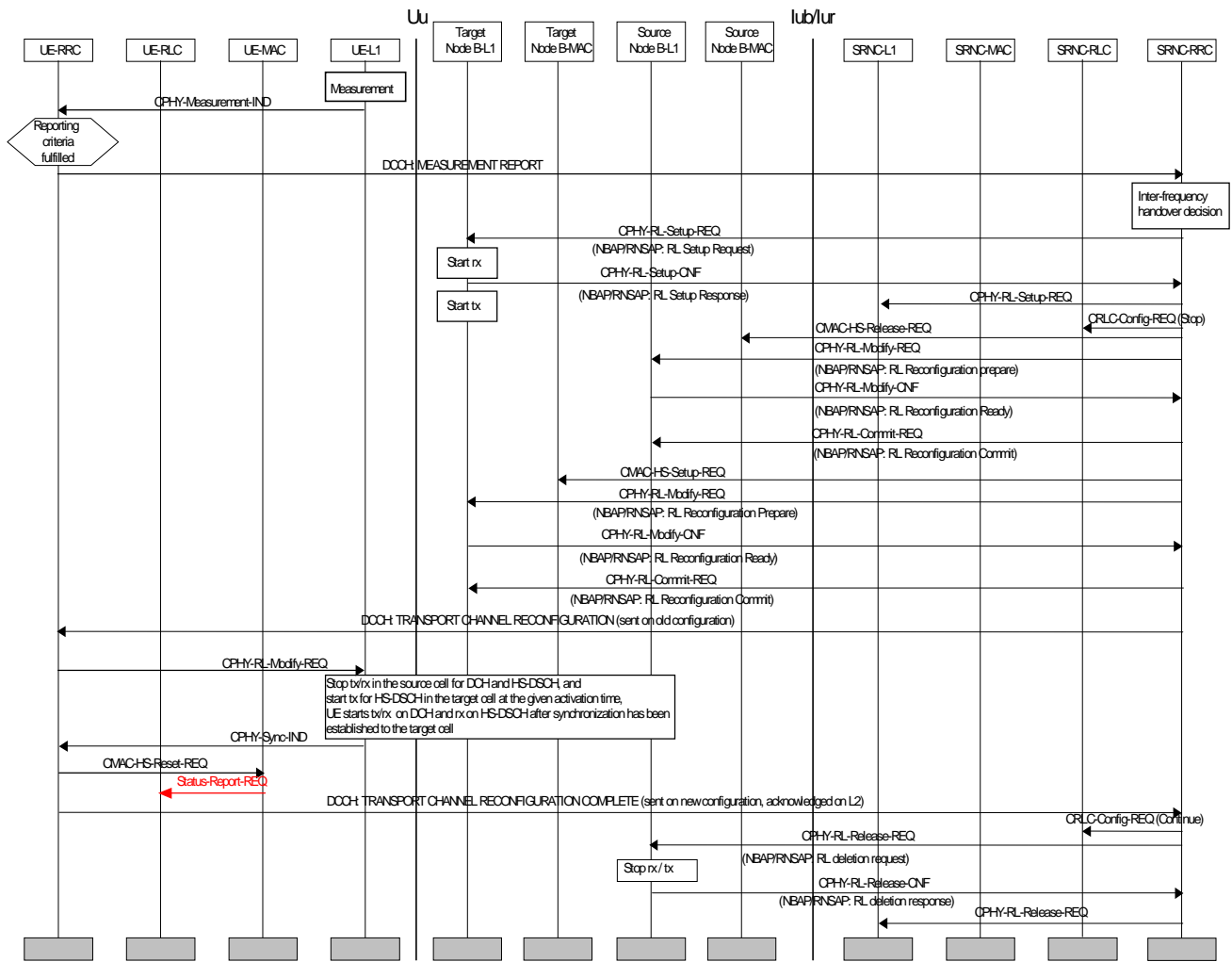

Figure 9.4-1: Inter-Node B synchronised serving HS-DSCH cell change during hard handover

9.5 Inter-Node B synchronised serving HS-DSCH cell change after active set update (radio link addition)

Figure 9.5-1 illustrates an inter-Node B serving HS-DSCH cell change performed subsequent to an active set update. In this example it is assumed that a new radio link is added which belongs to a target Node B different from the source Node B. The cell which is added to the active set is assumed to become the serving HS-DSCH cell in the second step. This combined procedure is comprised of an ordinary Active Set Update procedure in the first step and a synchronised serving HS-DSCH cell change in the second step.

We assume the UE transmits a MEASUREMENT REPORT message containing intra-frequency measurement results. The SRNC determines the need for the combined radio link addition and serving HS-DSCH cell change based on received measurement reports and/or load control algorithms (measurements may be performed in compressed mode for FDD).

As the first step, the SRNC establishes the new radio link in the target Node B for the dedicated physical channels and transmits an ACTIVE SET UPDATE message to the UE. The ACTIVE SET UPDATE message includes the necessary information for establishment of the dedicated physical channels in the added radio link (but not the HS-PDSCH). When the UE has added the new radio link it returns an ACTIVE SET UPDATE COMPLETE message.

The SRNC will now carry on with the next step of the procedure, which is the serving HS-DSCH cell change. The target HS-DSCH cell is the newly added radio link, so far only including dedicated physical channels. For the synchronised serving HS-DSCH cell change, both the source and target Node Bs are first prepared for execution of the handover at the activation time indicated with CPHY-RL-Commit-REQ primitive.

The SRNC then sends a TRANSPORT CHANNEL RECONFIGURATION message, which indicates the target HS-DSCH cell and the activation time to the UE. The message may also include a configuration of transport channel related parameters for the target HS-DSCH cell, including an indication to reset the MAC-hs entity and a status report for each RLC entity associated with the HS-DSCH should be generated.

Since source and target HS-DSCH cell are controlled by different Node Bs, MAC-hs in source and target Node B need to be released and setup, respectively, which is assumed to be done with CMAC-HS-Release-REQ and CMAC-HS-Setup-REQ primitives. These MAC-hs control primitives are assumed to be carried on the same NBAP/RNSAP messages, which carry the CPHY-RL-Reconfig-REQ primitives. Execution of release and setup of MAC-hs entities shall also be performed at the indicated activation time.

When the UE has completed the serving HS-DSCH cell change it returns a TRANSPORT CHANNEL RECONFIGURATION message to the network.

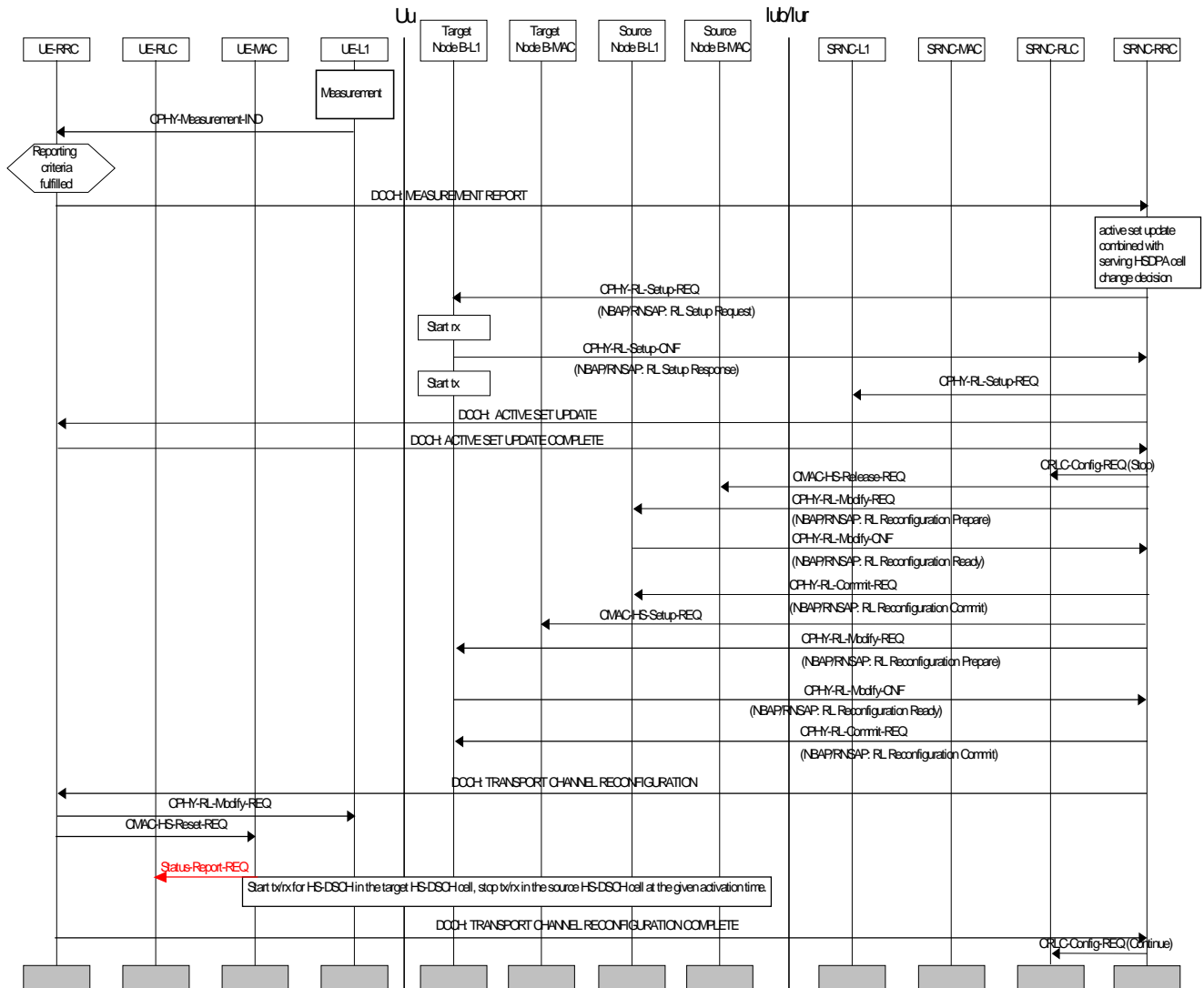

Figure 9.5-1: Inter-Node B synchronised serving HS-DSCH cell change after active set update