

TSG-RAN Meeting #15
Jeju-do, Korea, 5 - 8 March 2002

RP-020007

(S2-020276, copy TSG-RAN) LS on Restoration of R'96 Any Time Interrogation functionality

Title: Liaison Statement on Restoration of R'96 Any Time Interrogation functionality
Source: SA 2
To: RAN 3
Cc: RAN 2, GERAN 2, CN 2, SA 1, TSG-RAN, TSG-CN, TSG-SA

Attachments S2-020252, S2-020238, S2-020253

Contact Person:

Name: Chris Pudney
E-mail Address: chris.pudney@vf.vodafone.co.uk

1. Overall Description:

SA 2 have discussed the situation described in the attached S2-020252 and SA 2 believe that this problem needs to be removed from the 3GPP system.

A summary of the problem is as follows:

An Any Time Interrogate command can be sent from a CAMEL platform to an HLR in order to obtain the mobile's last known location. This triggers a Provide Subscriber information message to the MSC which, if the Gs interface is in use, triggers an MS Information Request message to the SGSN. If the mobile has an lu interface connection to the SGSN, then a Location Report Control message is sent to the RNC. If the mobile is in URA-PCH state but is out of coverage, then the RNC should return its most accurate location information to the SGSN. This would be the last known cell ID (mapped one to one to a Service Area ID). Currently the lu interface Location Report message cannot carry any 'age of location information' and so the SGSN will (because it has an active lu connection for that mobile) assume that the mobile is currently in coverage in that cell and insert "age=zero" information onto the Gs interface. This "age=zero" information will be incorrectly transported all the way back to the application.

This problem seems relatively easy to fix by

- (a) adding an 'age of location information' field (with its value given in minutes) to the lu Location report message, and,
- (b) by specifying that the SGSN copies the Age information from the lu interface onto the Gs interface (R'99 and onwards) and, for R'4 and onwards, onto the MAP interface to the GMLC.

A CR to correct the R'99 GPRS stage 2 specification 23.060 is attached in S2-020238. A **DRAFT** CR indicating one way that R'99 RANAP (25.413) could be updated is attached in S2-020253.

Obviously, this seems a relatively late change to R'99, but, it has to be recognised that we are discussing something which potentially damages services and features based on R'96.

However, the situation is not yet too serious. It should be recognised that, for R'99, this problem only relates to a subset of all operating scenarios. Namely the RNC only seems to need to be upgraded if:

- the operator is using a Gs interface between the MSC and SGSN to which the SRNC is connected,
- AND,
- the manufacturer/operator is using 'long lived' lu interface connections for mobiles that are in the URA-PCH state.

In R'4, the requirements on the RNC become stronger, because, in R'4 the GMLC can talk directly to the SGSN. For R'4, the RNC seems to need to be upgraded if:

the manufacturer/operator is using 'long lived' lu interface connections for mobiles that are in the URA-PCH state

AND

(

the operator is using a Gs interface between the MSC and SGSN to which the SRNC is connected,

OR

the operator has interface(s) to GMLC(s) from the SGSN.

)

When considering which versions of RANAP need to be updated, the key question seems to be "When will R'99 RANAP disappear from operator's networks?"

In order to answer this there is at least one related question, namely, "What mandatory new features are in R'4 or R'5 RANAP?" This question is important because, if R'4 or R'5 RANAP requires expensive upgrades, then, operators will remain with R'99 RANAP for a long period and hence it would be necessary to change R'99.

At least the first of these questions would appear to be a TSG-RAN/TSG-SA level issue. Hence SA 2 invites RAN 3 to prepare 'technically correct' R'99, R'4 and R'5 CRs to solve this problem, and, to leave the choice of "which release" to TSGs RAN and SA.

2. Actions:

To RAN 3 group:

SA2 invites RAN 3 :

- 1 to prepare 'technically correct' CRs to solve this problem for R'99, R4 and R'5 RANAP.
- 2 to provide guidance to RAN and SA as to the date RAN 3 believes "R'99 RANAP disappear from operator's networks?" (SA 2 note that commercial considerations may prevent this being achieved.)
- 3 to identify all mandatory new features on the R'4 and R'5 lu-ps interfaces.

To RAN 2, SA 1 and CN 2

To note this debate.

To GERAN 2

To take this issue into account with regard to the design and specification of the lu mode BSS.

To RAN, CN and SA plenaries

This document is for information. It is intended to help any debate on this topic which might occur at TSG level.

3. Date of Next SA2 Meetings:

SA2#23	18-22 February 2002 (Sophia Antipolis, France)
SA2#24	22-26 April 2002 (venue tbd)

3GPP TSG-SA2 Meeting #22
Phoenix, USA,14-18 January 2002

Tdoc S2-020238
rev of S2-020110

CR-Form-v4

CHANGE REQUEST

⌘ **23.060 CR 302** ⌘ **R1** ⌘ Current version: **3.10.0** ⌘

For **HELP** on using this form, see bottom of this page or look at the pop-up text over the ⌘ symbols.

Proposed change affects: ⌘ (U)SIM ME/UE Radio Access Network Core Network

Title:	⌘ Restoration of R'96 Any Time Interrogation functionality		
Source:	⌘ Vodafone		
Work item code:	⌘ TEI	Date:	⌘ 15 January 2002
Category:	⌘ F	Release:	⌘ R99
	Use <u>one</u> of the following categories:		Use <u>one</u> of the following releases:
	F (correction)	2 (GSM Phase 2)	
	A (corresponds to a correction in an earlier release)	R96 (Release 1996)	
	B (addition of feature),	R97 (Release 1997)	
	C (functional modification of feature)	R98 (Release 1998)	
	D (editorial modification)	R99 (Release 1999)	
	Detailed explanations of the above categories can be found in 3GPP TR 21.900 .	REL-4 (Release 4)	REL-5 (Release 5)

Reason for change: ⌘ In R'96, R'97 and R'98 it is possible to build many services based on the mobile's cell identity. This is either the cell where the mobile currently is, or, the cell where the mobile was last known to be. In the latter case, accurate information is supplied on "how long it has been since the mobile was last in contact with the network".

In R'99, the accuracy of the 'age of location' information has been lost in the case where the mobile is out of coverage but has an RRC connection to the SGSN, eg the mobile is in the URA_PCH state. Note that the periodic URA update timer (T305) can take values from the set {5, 10, 30, 60, 120, 360, 720 or infinity} minutes, so this 'loss of coverage while an RRC connection is active' is a real possibility.

Further information and example message flows are given in the document inserted into the 'other comments' field below. But it can be summarised as follows:

An Any Time Interrogate command can be sent from a CAMEL platform to an HLR in order to obtain the mobile's last known location. This triggers a Provide Subscriber information message to the MSC which, if the Gs interface is in use, triggers an MS Information Request message to the SGSN. If the mobile has an lu interface connection to the SGSN, then a Location Report Control message is sent to the RNC. If the mobile is in URA-PCH state but is out of coverage, then the RNC should return its most accurate location information to the SGSN. This would be the last known cell ID (mapped one to one to a Service Area ID). Currently the lu interface Location Report message cannot carry any 'age of location information' and so the SGSN will (because it has an active lu connection for that mobile) assume that the mobile is currently in coverage in that cell and insert "age=zero" information onto the Gs interface. This "age=zero" information will be incorrectly transported all the way back to the application.

This behaviour is incorrect and this CR attempts to correct the stage 2 description.

This CR is one of a set of CRs that aims to restore the R'96 capability to the R'99 system.

Summary of change:	⌘ When the RNC cannot determine the current Cell Id of the mobile, the RNC shall report an indication of how long has past since the mobile was known to be in the indicated cell.
Consequences if not approved:	⌘ Services based on Cell ID/SAI will randomly and unpredictably fail by indicating that the 'mobile is active in a specific cell' while, in reality, the mobile might have been switched off while out of coverage (or had the battery removed) hours ago in that cell. Note that this might be particularly problematic for law enforcement functions. For other services, note that changes in configuration of the VPLMN (eg URA timer, installation of Gs interface) could unpredictably alter the performance of HPLMN functions.

Clauses affected:	⌘ 6.3.6									
Other specs Affected:	<table border="0"> <tr> <td data-bbox="454 728 494 772">⌘</td> <td data-bbox="494 728 877 772"><input checked="" type="checkbox"/> Other core specifications</td> <td data-bbox="877 728 1445 772">⌘ 25.413</td> </tr> <tr> <td data-bbox="454 772 494 817">⌘</td> <td data-bbox="494 772 877 817">Test specifications</td> <td></td> </tr> <tr> <td data-bbox="454 817 494 862">⌘</td> <td data-bbox="494 817 877 862">O&M Specifications</td> <td></td> </tr> </table>	⌘	<input checked="" type="checkbox"/> Other core specifications	⌘ 25.413	⌘	Test specifications		⌘	O&M Specifications	
⌘	<input checked="" type="checkbox"/> Other core specifications	⌘ 25.413								
⌘	Test specifications									
⌘	O&M Specifications									
Other comments:	⌘ For release '4, 29.002 and [23.171] may also be impacted to describe the interworking between the lu interface and the MAP interface to the GMLC. The related document S2-020252 is attached below.  S2-020252.zip									

6.3.6 MS Information Procedure

When the MS is marked at the VLR as both IMSI- and GPRS-attached, the VLR may perform the MS Information procedure via the SGSN. If the information requested by the VLR in the MS Information procedure is known by the SGSN, then the SGSN shall return this information to the VLR without interrogating the MS.

If the information requested is MS identity information (e.g., IMEI) that is not known by the SGSN but is known by the MS, then the SGSN shall interrogate the MS in a similar manner to that described in subclause "Identity Check Procedures".

In A/Gb mode, if the information requested is MS location information, then this indicates a request for Cell Global Identity and Cell Identity Age. In Iu mode, if the information requested is MS location information, then this indicates a request for Service Area Identity and Service Area Code Age, and in this case if an Iu connection for the MS exists, then the SGSN shall use the Location Reporting procedure (see subclause "Location Reporting Procedure") in order to retrieve the Service Area Identity and Service Area Code Age.

The MS Information procedure is illustrated in **Error! Reference source not found.** Procedure steps are explained in the following list.

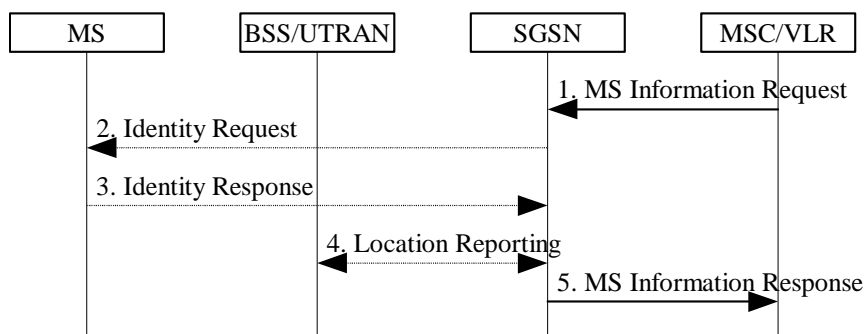

Figure 1: MS Information Procedure

- 1) The MSC/VLR sends an MS Information Request (IMSI, Information Type) message to the SGSN. Information Type indicates the information that the MSC/VLR is requesting for that IMSI.
- 2) If the information requested is not known by the SGSN but should be known by the MS, then the SGSN interrogates the MS in a similar manner to that described in the subclause "Identity Check Procedures". The SGSN sends an Identity Request (Identity Type) message to the MS.
- 3) The MS responds with an Identity Response (Mobile Identity) message to the SGSN.
- 4) In Iu mode, if an Iu connection for the MS exists, then the SGSN shall use the Location Reporting procedure to retrieve the current or last known Service Area Identity and the Service Area Code Age.
- 5) The SGSN sends an MS Information Response (IMSI, Information) message to the MSC/VLR. Information contains the information requested by the MSC/VLR.

Source: Vodafone
Title: Problem with SGSN location reporting behaviour with and without an Iu 'connection' to the UE
Document for: Information
Agenda Item: 6 (R'99 and earlier)

1 Introduction

With R'96, R'97 and R'98 it has been possible to build services based on the last known "GSM cell ID" of the mobile. Unfortunately, R'99 (and later) seems to have damaged this functionality. Vodafone would like to see this functionality restored.

2 Summary of problem

An Any Time Interrogate command can be sent from a CAMEL platform to an HLR in order to obtain the mobile's last known location. This triggers a Provide Subscriber information message to the MSC which, if the Gs interface is in use, triggers an MS Information Request message to the SGSN. If the mobile has an Iu interface connection to the SGSN, then a Location Report Control message is sent to the RNC. If the mobile is in URA-PCH state but is out of coverage, then the RNC should return its most accurate location information to the SGSN. This would be the last known cell ID (mapped one to one to a Service Area ID). Currently the Iu interface Location Report message cannot carry any 'age of location information' and so the SGSN will (because it has an active Iu connection for that mobile) assume that the mobile is currently in coverage in that cell and insert "age=zero" information onto the Gs interface. This "age=zero" information will be incorrectly transported all the way back to the application.

This problem seems relatively easy to fix by

- (a) adding an 'age of location information' field to the Iu Location report message, and,
- (b) specifying that the SGSN copies the Age information from the Iu interface onto the Gs interface (R'99 and onwards) and, for R'4 and onwards, onto the MAP interface to the GMLC.

The following figures show how existing functionality can be used, and the impact of the introduction of UMTS.

3 Basic GSM R'96 procedure to find last known Cell ID

Any Time Interrogation and Provide Subscriber Information are MAP messages that provide CAMEL functionality.

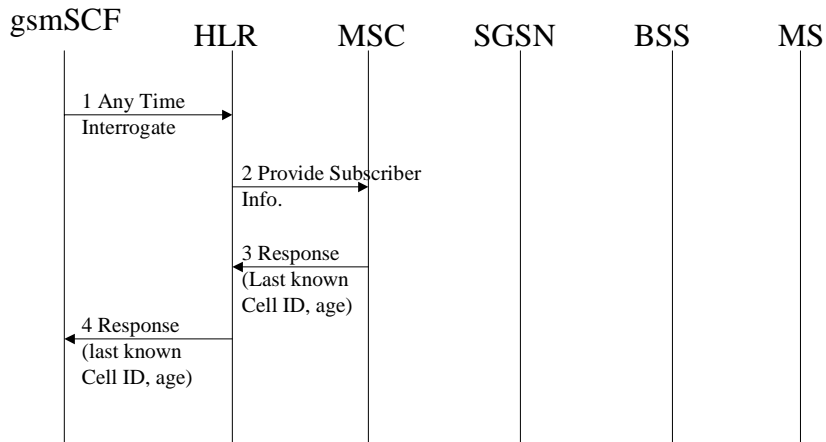

Fig 1. GSM mobile, not connected to MSC, no Gs interface

If the mobile is not in a call, then the MSC can return the last known Cell ID and the 'age' of this location information. The Age information is in minutes. Age is probably used to avoid any need for the MSC to accurately know the time.

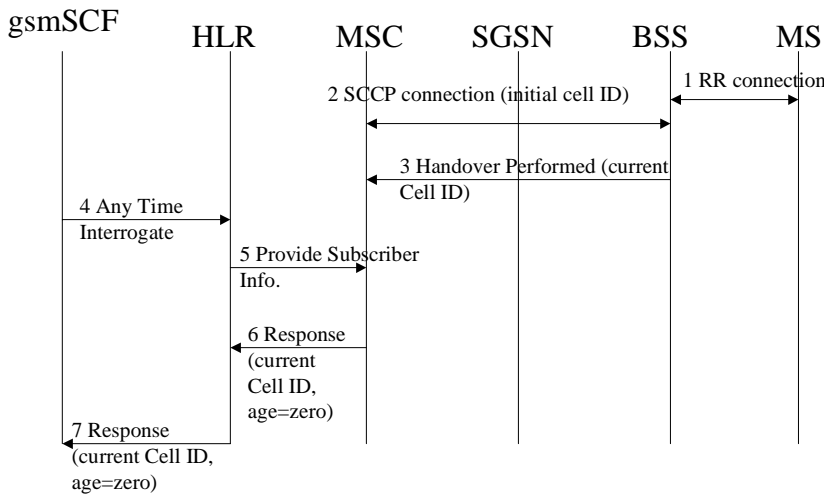

Fig 2. GSM mobile, connected to MSC

If the mobile is in a call with the MSC, the BSS always informs the MSC of every cell change that the mobile makes. Hence the MSC always knows which cell a mobile is using during a GSM call. When the mobile is in a call, the MSC sets the “Age” field to zero to indicate that the mobile is ‘connected’ and that the cell information is totally up to date.

2 Basic UMTS MSC procedure to find last known Cell ID

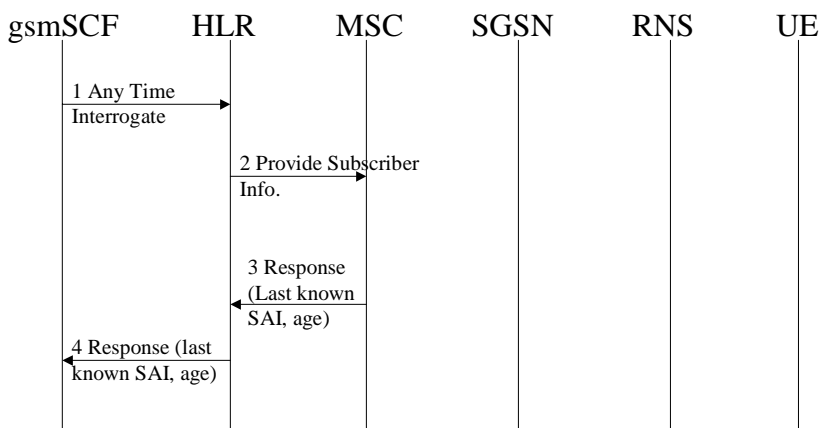

Fig 3. UMTS mobile, not connected to MSC, no Gs interface

This is basically the same as GSM, except that MAP carries the SAI rather than the Cell ID.

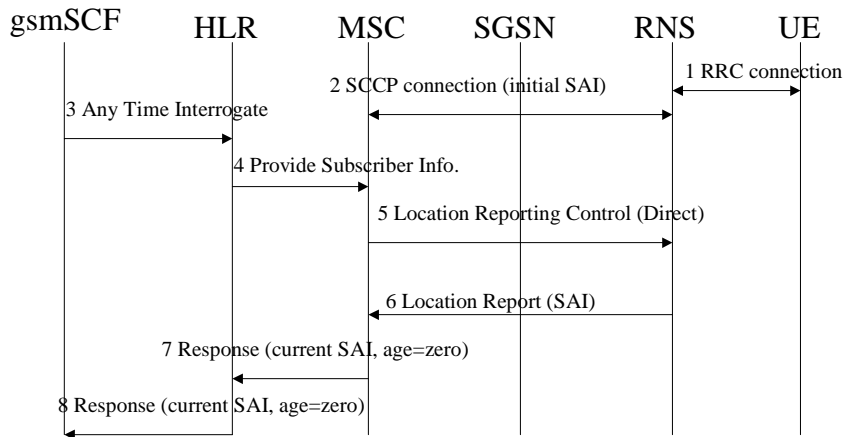

Fig 4. UMTS mobile, connected to MSC

In UMTS, the UTRAN does not automatically report all cell changes to the MSC. Hence when the mobile is in a call and the HLR asks for the last known cell ID, then the MSC has to invoke the Iu interface Location Reporting Control procedure.

4 GSM R'97 procedure to find last known Cell ID with Gs interface

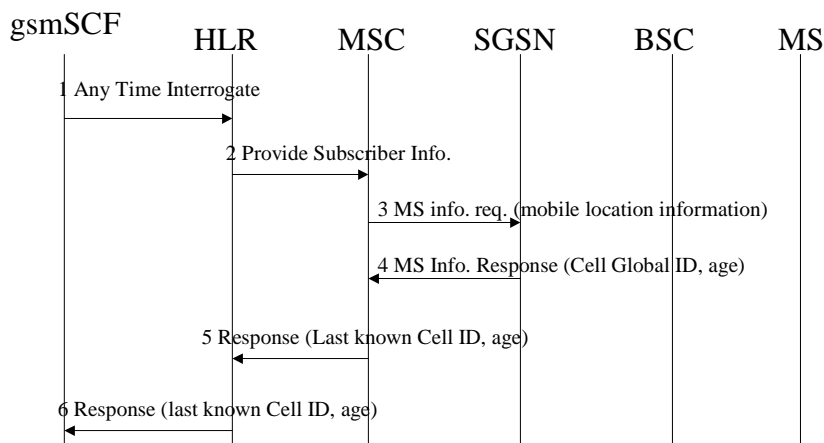

Fig 5. GSM MS attached to CS and PS domain. No A interface connection to MSC. Gs interface present.

When the mobile is not in a call, but the mobile is attached via the SGSN and Gs interface, the Gs interface signalling is used to obtain the Cell ID from the SGSN.

4 R'99 procedure to find last known SAI with Gs interface

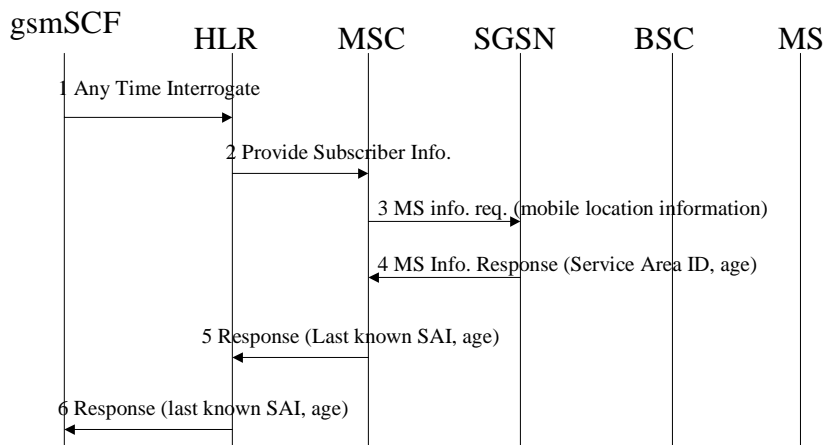

Fig 6. UMTS MS attached to CS and PS domains. No Iu interface connection to MSC or SGSN. Gs interface present

When the mobile does not have an RRC connection (and hence no Iu connection), this procedure is very similar to that for GSM R'97, except that SAI is returned rather than CGI.

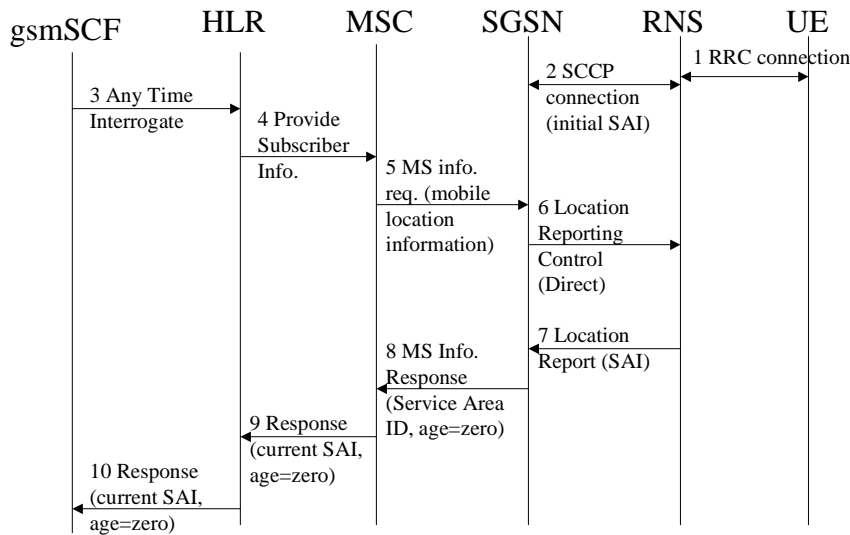

Fig 7. UMTS MS attached to CS and PS domains. No Iu interface connection to MSC. Gs interface present. Iu interface connection to SGSN. MS not in URA-PCH state.

When there is an Iu interface connection with only the SGSN, and the mobile is in coverage, then the above procedure returns the current SAI, and, the SGSN/MSC correctly adds an "Age=zero" field.

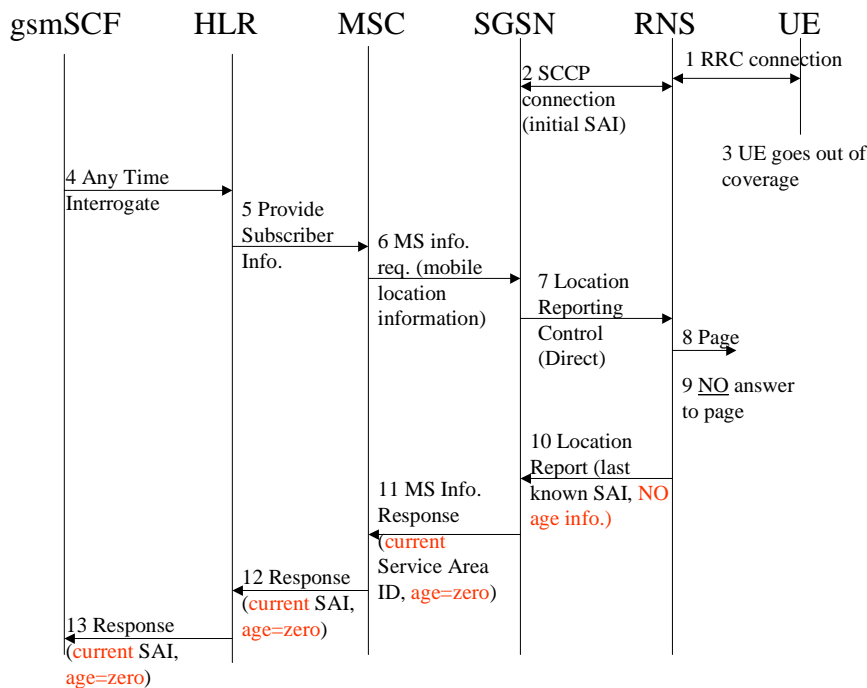

Fig 8. UMTS MS attached to CS and PS domains. No Iu interface connection to MSC. Gs interface present. Iu interface connection to SGSN. MS in URA-PCH state, but out of coverage. **Current (incorrect) behaviour. Problems shown in red.**

However, when there is one Iu interface connection to the SGSN but the mobile has temporarily gone out of coverage, then, what happens?

A decent implementation of the RNC should return its most accurate information, namely the last known cell ID (converted by a one to one mapping into SAI) along with an indication of how long ago that the mobile was in that cell. Unfortunately, the Iu interface signalling does not carry an “age of location field”.

Even worse, the SGSN regards the out of coverage mobile as “connected” and adds a “age=zero” field to the information returned to the MSC/HLR.

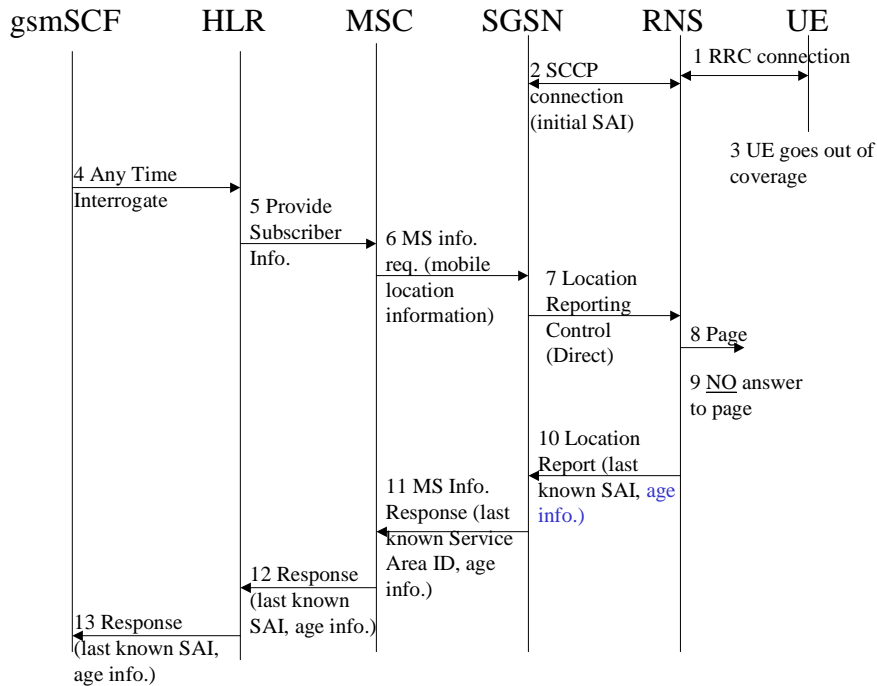

Fig 9. UMS MS attached to CS and PS domains. No Iu interface connection to MSC. Gs interface present. Iu interface connection to SGSN. MS in URA-PCH state, but out of coverage.

Proposed modified (correct) behaviour. Changes to existing signalling protocols shown in blue. This problem seems relatively easy to fix by

- (a) adding an 'age of location information' field to the Iu Location report message, and,
- (b) specifying that the SGSN copies the Age information from the Iu interface onto the Gs interface (R'99 and onwards) and, for R'4 and onwards, onto the MAP interface to the GMLC.

3GPP TSG-SA2 Meeting #22
Phoenix, USA,14-18 January 2002

Tdoc S2-020253

CR-Form-v4

CHANGE REQUEST

⌘ 25.413 CR _____ ⌘ _____ ⌘ Current version: 3.7.0 ⌘

For **HELP** on using this form, see bottom of this page or look at the pop-up text over the ⌘ symbols.

Proposed change affects: ⌘ (U)SIM ME/UE Radio Access Network Core Network

Title:	⌘ Restoration of R'96 Any Time Interrogation functionality		
Source:	⌘ Vodafone		
Work item code:	⌘ TEI	Date:	⌘ 15 January 2002
Category:	⌘ F	Release:	⌘ R99
	Use <u>one</u> of the following categories:		Use <u>one</u> of the following releases:
	F (correction)		2 (GSM Phase 2)
	A (corresponds to a correction in an earlier release)		R96 (Release 1996)
	B (addition of feature),		R97 (Release 1997)
	C (functional modification of feature)		R98 (Release 1998)
	D (editorial modification)		R99 (Release 1999)
	Detailed explanations of the above categories can be found in 3GPP TR 21.900 .		REL-4 (Release 4)
			REL-5 (Release 5)

Reason for change: ⌘ In R'96, R'97 and R'98 it is possible to build many services based on the mobile's cell identity. This is either the cell where the mobile currently is, or, the cell where the mobile was last known to be. In the latter case, accurate information is supplied on "how long it has been since the mobile was last in contact with the network".

In R'99, the accuracy of the 'age of location' information has been lost in the case where the mobile is out of coverage but has an RRC connection to the SGSN, eg the mobile is in the URA_PCH state. Note that the periodic URA update timer (T305) can take values from the set {5, 10, 30, 60, 120, 360, 720 or infinity} minutes, so this 'loss of coverage while an RRC connection is active' is a real possibility.

Further information and example message flows are given in the document inserted into the 'other comments' field below. But it can be summarised as follows:

An Any Time Interrogate command can be sent from a CAMEL platform to an HLR in order to obtain the mobile's last known location. This triggers a Provide Subscriber information message to the MSC which, if the Gs interface is in use, triggers an MS Information Request message to the SGSN. If the mobile has an lu interface connection to the SGSN, then a Location Report Control message is sent to the RNC. If the mobile is in URA-PCH state but is out of coverage, then the RNC should return its most accurate location information to the SGSN. This would be the last known cell ID (mapped one to one to a Service Area ID). Currently the lu interface Location Report message cannot carry any 'age of location information' and so the SGSN will (because it has an active lu connection for that mobile) assume that the mobile is currently in coverage in that cell and insert "age=zero" information onto the Gs interface. This "age=zero" information will be incorrectly transported all the way back to the application.

This behaviour is incorrect and this CR attempts to correct the RANAP description.

It is also worth noting that the RANAP behaviour appears to be out of line with the

	<p>behaviour specified in section 8.1.1 of 25.305 v3.7.0 which states</p> <p>“Alternatively, the cell ID may be determined as the one that was used during the last active connection to the UE. This determination should be accompanied by the time-of-day of the last connection in the cell.”</p> <p>This CR is one of a set of CRs that aims to restore the R'96 capability to the R'99 system.</p>									
<p>Summary of change: ⌘</p>	<p>When the RNC cannot determine the current Cell Id of the mobile, the RNC shall report an indication of how long has past since the mobile was known to be in the indicated cell.</p> <p>For R'99, this change is only needed on the lu-ps interface AND when the core network is using the Gs interface AND when the RNC does not rapidly release the lu connection when radio 'activity' has ceased. The RNC's RRC-connection release timer also controls the release of the lu connection. It would normally be set equal to "T305+a guard timer". The guard timer allows time for the mobile to contact the RNC following T305 expiry in the mobile. A typical value for the guard timer could be 3 minutes, in which case the RRC connection release timer could have values from the set {(less than 5), 8, 13, 33, 63, 123, 363, 723 or infinity} minutes.</p> <p>In order to achieve reasonable accuracy of the age information, the value 8 minutes is suggested in this CR.</p> <p>Isolated impact:</p> <p>If this change is implemented first on the RNC, then the SGSN will ignore the new IE and act as it did previously.</p> <p>If this change is implemented first on the SGSN, then if the SGSN does not receive the Area Identity Age IE, the SGSN would just assume that the RRC connection release timer was less than 8 minutes.</p>									
<p>Consequences if not approved:</p>	<p>⌘ Services based on Cell ID/SAI will randomly and unpredictably fail by indicating that the 'mobile is active in a specific cell' while, in reality, the mobile might have been switched off while out of coverage (or had the battery removed) hours ago in that cell. Note that this might be particularly problematic for law enforcement functions.</p> <p>For other services, note that changes in configuration of the VPLMN (eg URA timer, installation of Gs interface) could unpredictably alter the performance of HPLMN functions.</p>									
<p>Clauses affected:</p>	<p>⌘ 6.3.6</p>									
<p>Other specs Affected:</p>	<table border="0"> <tr> <td>⌘ <input checked="" type="checkbox"/></td> <td>Other core specifications</td> <td>⌘ 23.060</td> </tr> <tr> <td><input type="checkbox"/></td> <td>Test specifications</td> <td></td> </tr> <tr> <td><input type="checkbox"/></td> <td>O&M Specifications</td> <td></td> </tr> </table>	⌘ <input checked="" type="checkbox"/>	Other core specifications	⌘ 23.060	<input type="checkbox"/>	Test specifications		<input type="checkbox"/>	O&M Specifications	
⌘ <input checked="" type="checkbox"/>	Other core specifications	⌘ 23.060								
<input type="checkbox"/>	Test specifications									
<input type="checkbox"/>	O&M Specifications									
<p>Other comments:</p>	<p>⌘ For release '4, 29.002 and [23.171] may also be impacted to describe the interworking between the Iu interface and the MAP interface to the GMLC.</p>									

8.19 Location Reporting Control

8.19.1 General

The purpose of the Location Reporting Control procedure is to allow the CN to request information on the location of a given UE. The procedure uses connection oriented signalling.

8.19.2 Successful Operation



Figure 1: Location Reporting Control procedure. Successful operation.

The CN shall initiate the procedure by generating a LOCATION REPORTING CONTROL message.

The *Request Type* IE shall indicate to the serving RNC whether:

- to report directly;
- to report upon change of Service area, or
- to stop reporting at change of Service Area.

If reporting upon change of Service Area is requested, the Serving RNC shall report whenever the UE moves between Service Areas. For this procedure, only Service Areas that are defined for the PS and CS domains shall be considered.

The *Request Type* IE shall also indicate what type of location information the serving RNC shall report. The location information is either of the following types:

- Service Area Identifier, or
- Geographical coordinates, with or without requested accuracy.

A request for a direct report can be done in parallel with having an active request to report upon change of Service Area for the same UE. The request to report upon change of Service Area shall not be affected by this.

Interaction with Relocation:

The order to perform location reporting at change of Service Area is lost in UTRAN at successful Relocation of SRNS. If the location reporting at change of Service Area shall continue also after the relocation has been performed, the Location Reporting Control procedure shall thus be re-initiated from the CN towards the future SRNC after the Relocation Resource Allocation procedure has been executed successfully.

8.19.3 Abnormal Conditions

Not applicable.

8.20 Location Report

8.20.1 General

The purpose of the Location Report procedure is to provide the UE's location information to the CN. The procedure uses connection oriented signalling.

8.20.2 Successful Operation

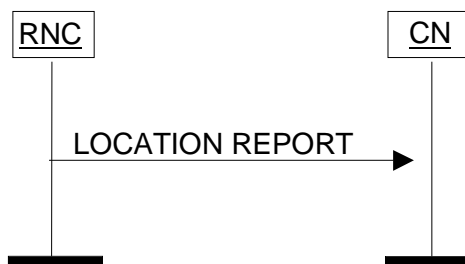

Figure 2: Location Report procedure. Successful operation.

The serving RNC shall initiate the procedure by generating a LOCATION REPORT message. The LOCATION REPORT message may be used as a response for the LOCATION REPORTING CONTROL message. Also, when a user enters or leaves a classified zone set by O&M, e.g. zone where a disaster occurred, a LOCATION REPORT message shall be sent to the CN including the Service Area of the UE in the *Area Identity* IE. The *Cause* IE shall indicate the appropriate cause value to CN, e.g. "User Restriction Start Indication" and "User Restriction End Indication". The CN shall react to the LOCATION REPORT message with CN vendor specific actions.

For this procedure, only Service Areas that are defined for the PS and CS domains shall be considered.

In case reporting at change of Service Area is requested by the CN, then the RNC shall issue a LOCATION REPORT message

- whenever the information given in the previous LOCATION REPORT message or INITIAL UE MESSAGE message is not anymore valid.
- upon receipt of the first LOCATION REPORTING CONTROL message following a Relocation Resource Allocation procedure, with *Request Type* IE set to "Change of Service Area", as soon as SAI becomes available in the new SRNC and the relocation procedure has been successfully completed.

In the case when Service Area is reported, the RNC shall include to the LOCATION REPORT message in the *Area Identity* IE the Service Area, which includes at least one of the cells from which the UE is consuming radio resources.

When the LOCATION REPORT is sent to the PS domain of the CN, and, the CN is using the Gs interface, and, the RRC-Connection-Release timer (see section "Iu Release Procedure" in 3GPP TS 23.060 [21]) has a value greater than 8 minutes, then the *Area Identity Age* IE shall be included by the SRNC.

The *Area Identity Age* IE indicates how long ago (in minutes) the Area Identity Information was obtained. When the UE is currently in contact with the network, a value of zero minutes is used.

If the RNC can not deliver the location information as requested by the CN, the RNC shall indicate the UE location to be "Undetermined" by omitting the *Area Identity* IE. A cause value shall instead be added to indicate the reason for the undetermined location, e.g. "Requested Report Type not supported". If the *Cause* IE is set to "Requested Report Type not supported" the *Request Type* IE shall be included as a reference of what report type is not supported.

If the Location Report procedure was triggered by a LOCATION REPORTING CONTROL message, which included a request for a geographical area with a specific accuracy, the LOCATION REPORT message shall include either a point with indicated uncertainty or a polygon, which both shall fulfill the requested accuracy as accurately as possible. If, on the other hand, no specific accuracy level was requested in the LOCATION REPORTING CONTROL message, it is up to UTRAN to decide with which accuracy to report.

8.20.3 Abnormal Conditions

Not applicable.

9.1.29 LOCATION REPORTING CONTROL

This message is sent by the CN to initiate, modify or stop location reporting from the RNC to the CN.

Direction: CN → RNC.

Signalling bearer mode: Connection oriented.

IE/Group Name	Presence	Range	IE type and reference	Semantics description	Criticality	Assigned Criticality
Message Type	M		9.2.1.1		YES	ignore
Request Type	M		9.2.1.16		YES	ignore

9.1.30 LOCATION REPORT

This message is sent by the RNC to the CN with information about the UE location.

Direction: RNC → CN.

Signalling bearer mode: Connection oriented.

IE/Group Name	Presence	Range	IE type and reference	Semantics description	Criticality	Assigned Criticality
Message Type	M		9.2.1.1		YES	ignore
Area Identity	O		9.2.3.10		YES	ignore
Cause	O		9.2.1.4		YES	ignore
Request Type	C – ifReqType NS		9.2.1.16		YES	ignore
<u>Area Identity Age</u>	<u>O</u>		<u>9.2.1.43</u>		<u>YES</u>	<u>ignore</u>

Condition	Explanation
IfReqTypeNS	This IE shall be present if the Cause IE is set to "Requested Report Type not supported".

9.2.1.43 Area Identity Age

This IE indicates how long ago (in minutes) the Area Identity Information was obtained.

<u>IE/Group Name</u>	<u>Presence</u>	<u>Range</u>	<u>IE type and reference</u>	<u>Semantics description</u>
<u>Area Identity Age</u>	<u>M</u>		<u>INTEGER (0...32767)</u>	<u>The value represents the elapsed time in minutes since the last network contact of the UE (i.e. the actuality of the Area Identity information).</u> <u>Value "0" indicates that the UE is currently in contact with the network.</u> <u>Value "32767" indicates that the Area Identity information is at least 32767 minutes old.</u>