

Technical Specification Group, Radio Access Network

TSGR#9 RP-000490

Meeting #9, Hawaii, 20-22 September 2000

Source: TSG RAN WG4
Title: TR 25.945, RF requirements for 1.28Mcps UTRA TDD option
Document for: Approval
Agenda Item: 6.1 (Release'00 work plan and Status update)

3G TR 25.945 V0.3.0(2000-09)

Technical Report

**3rd Generation Partnership Project (3GPP);
Technical Specification Group (TSG);
Radio Access Network (RAN);
RF requirements for 1.28Mcps UTRA TDD option**



Reference

DTS/TSGR-0125223
(25223-300.PDF)

Keywords

<keyword[, keyword]>

3GPP

Postal address

Office address

Internet

secretariat@3gpp.org

Individual copies of this deliverable
can be downloaded from
<http://www.3gpp.org>

Copyright Notification

No part may be reproduced except as authorized by written permission.
The copyright and the foregoing restriction extend to reproduction in all media.

© 1999, 3GPP Organizational Partners (ARIB, CWTS, ETSI, T1, TTA, TTC).

All rights reserved.

Contents

1	Scope	17
2	References	17
3	Abbreviations	18
4	RF Parameters in Support of Radio Resource Management	19
4.1	Idle Mode Tasks	19
4.1.1	Introduction	19
4.1.2	RF Cell Selection Scenario	19
4.1.2.1	Requirements for Cell Selection single carrier single cell case.....	19
4.1.2.2	Requirements for Cell Selection single carrier multi cell case.....	19
	RF Cell Re-Selection Scenario.....	19
4.1.3.1	Requirements for Cell Re-Selection single carrier multi cell case.....	19
4.1.3.2	Requirements for UTRAN to GSM Cell Re-Selection	19
4.2	RRC Connection mobility.....	19
4.2.1	Handover	19
4.2.1.1	Introduction.....	19
4.2.1.2	1.28Mcps TDD/1.28Mcps TDD Handover.....	20
4.2.1.2.1	Requirements.....	20
4.2.1.2.1.1	Maximum number of cells to be monitored.....	20
4.2.1.2.1.2	Measurement reporting delay	20
4.2.1.2.1.2.1	Correct reporting of neighbours in AWGN propagation condition.....	20
4.2.1.2.1.2.1.1	Requirements	22
4.2.1.2.1.3	Handover Delay	22
4.2.1.3	Handover 3G to 2G	22
4.2.1.3.1	Handover to GSM	22
4.2.2	Radio Link Management	23
4.2.2.1	Link adaptation	23
4.2.3	Cell Update	23
4.2.4	URA Update	23
4.3	RRC Connection Control	23
4.3.1	Radio Access Bearer Control.....	23
4.4	Dynamic Channel Allocation	23
4.4.1	Introduction	23
4.4.2	Implementation Requirements	23
4.4.3	Number of timeslots to be measured	23
4.4.4	Measurement reporting delay	23
4.5	Timing characteristics	23
4.5.1	Timing Advance (TA) Requirements for 1.28Mcps TDD option)	23
4.5.1.1	RX Timing Deviation.....	24
4.6	Measurements Performance Requirements	24

4.6.1	Measurements Performance for UE for 1.28Mcps TDD option	25
4.6.1.1	Performance for UE Measurements in Downlink (RX)	25
4.6.1.1.1	COMMON CONTROL PHYSICAL CHANNEL MEASUREMENTS	25
4.6.1.1.1.1	P-CCPCH RSCP (1.28Mcps TDD)	25
4.6.1.1.1.1.1	Intra frequency test parameters	25
4.6.1.1.1.1.2	Absolute accuracy requirements	26
4.6.1.1.1.1.3	Relative accuracy requirements.....	26
4.6.1.1.1.1.4	Range/mapping 26	
4.6.1.1.3	UTRA carrier RSSI	27
4.6.1.1.3.1	Test parameters for requirement	27
4.6.1.1.3.2	Absolute accuracy requirement.....	27
4.6.1.1.3.3	Relative accuracy requirement.....	27
4.6.1.1.3.4	Range/mapping	28
4.6.1.1.7	SFN-SFN observed time difference.....	28
4.6.1.1.7.1	Accuracy requirements.....	28
4.6.1.1.7.2	Range/mapping 28	
4.6.2	Measurements Performance for UTRAN in 1.28Mcps TDD option	29
4.6.2.1	Performance for UTRAN Measurements in Uplink (RX)	29
4.6.2.1.8	RX Timing Deviation	29
4.6.2.1.8.1	Accuracy requirements	29
4.6.2.1.8.2	Range/mapping	30
	Annex 4.A RF Power Management Scenario.....	31
	Annex 4.B RF Handover Scenario.....	31
	5 UE Radio Transmission and Reception.....	32
5.1	Frequency bands and channel arrangement.....	32
5.1.1	General	32
5.1.2	Frequency bands	32
5.1.3	TX–RX frequency separation	32
5.1.4	Channel arrangement	32
5.1.4.1	Channel spacing	32
5.1.4.1.1	Background32	
5.1.4.1.2	Channel spacing	33
5.1.4.2	Channel raster	33
5.1.4.3	Channel number	33
5.2	Transmitter characteristics	33
5.2.1	General	33
5.2.2	Transmit power.....	33
5.2.2.1	User Equipment maximum output power	33
5.2.3	UE frequency stability	33
5.2.4	Output power dynamics.....	33
5.2.4.1	Open loop power control.....	33
5.2.4.1.1	minimum requirement	33
5.2.4.2	Close loop power control in the uplink.....	34
5.2.4.2.1	Power control steps	34

5.2.4.2.1.1	Minimum requirement.....	34
5.2.4.3	Minimum transmit output power	35
5.2.4.3.1	Minimum requirement	35
[Rationale:]	35	
5.2.5	Transmit ON/OFF power.....	35
5.2.5.1	Transmit OFF power	35
5.2.5.1.1	Minimum Requirement	35
5.2.5.2	Transmit ON/OFF Time mask	36
5.2.6	Output RF spectrum emissions	36
5.2.6.1	Occupied bandwidth	36
5.2.6.2	Out of band emission	36
5.2.6.2.1	Spectrum emission mask	36
5.2.6.2.2	Adjacent Channel Leakage power Ratio (ACLR).....	37
5.2.6.3	Spurious emissions.....	37
5.2.6.3.1	Minimum Requirement	37
5.2.7	Transmit intermodulation	38
5.2.7.1	Minimum requirements.....	38
5.2.8	Transmit Modulation	38
5.2.8.1	Transmit pulse shape filter.....	38
5.2.8.2	Modulation Accuracy.....	39
5.2.8.2.1	Minimum Requirement	39
5.2.8.3	Peak Code Domain Error	39
5.2.8.3.1	Minimum Requirement	39
5.3	Receiver characteristics	39
5.3.1	General	39
5.3.2	Diversity characteristics.....	39
5.3.3	Reference sensitivity level.....	39
5.3.3.1	Minimum Requirements	39
5.3.4	Maximum input level.....	41
5.3.4.1	Minimum Requirements	41
5.3.5	Adjacent Channel Selectivity (ACS)	41
5.3.5.1	Minimum Requirement.....	41
5.3.6	Blocking characteristics.....	42
5.3.6.1	Minimum Requirement.....	42
5.3.7	Spurious response	44
5.3.7.1	Minimum Requirements	44
5.3.8	Intermodulation characteristics.....	45
5.3.8.1	Minimum Requirements	45
5.3.9	Spurious emissions	45
5.3.9.1	Minimum Requirement.....	45
5.4	Performance requirement	46
5.4.1	General	46
5.4.2	Demodulation in static propagation conditions	47
5.4.2.1	Demodulation of DCH	47

5.4.2.1.1	Minimum requirement.....	47
5.4.3	Demodulation of DCH in multipath fading conditions.....	48
5.4.3.1	Multipath fading Case 1.....	48
5.4.3.1.1	Minimum requirement.....	48
5.4.3.2	Multipath fading Case 2.....	48
5.4.3.2.1	Minimum requirement.....	48
5.4.3.3	Multipath fading Case 3.....	49
5.4.3.3.1	Minimum requirement.....	49
Annex 5.A (normative): Measurement Channels.....		50
5.A.1	General.....	50
5.A.2	Reference Measurement Channels.....	50
5.A.2.1	DL reference measurement channel (12.2 kbps).....	50
5.A.2.2	DL reference measurement channel (64 kbps).....	51
5.A.2.3	DL reference measurement channel (144 kbps).....	52
5.A.2.4	DL reference measurement channel (384 kbps).....	54
Annex 5.B (normative): Propagation conditions.....		56
5.B.1	Static Propagation conditions.....	56
5.B.2	multi-path fading Propagation conditions.....	56
Annex 5.C (normative): Environmental conditions.....		56
5.C.1	General.....	56
5.C.2	Environmental requirements for the UE.....	57
5.C.2.1	Temperature.....	57
5.C.2.2	Voltage 57	
5.C.2.3	Vibration 57	
[Rationale:]	58	
6 BS radio transmission and reception.....		58
6.1	Frequency bands and channel arrangement.....	58
6.1.1	General.....	58
6.1.2	Frequency bands.....	58
6.1.3	TX–RX frequency separation.....	58
6.1.4	Channel arrangement.....	59
6.1.4.1	Channel spacing.....	59
6.1.4.1.1	Background 59	
6.1.4.1.2	Channel spacing.....	59
6.1.4.2	Channel raster.....	59
6.1.4.3	Channel number.....	59
6.2	Transmitter characteristics.....	59
6.2.1	General.....	59
6.2.2	Base station output power.....	59
6.2.2.1	Base station maximum output power.....	60
6.2.2.1.1	Minimum requirement.....	60
6.2.3	Frequency stability.....	60

6.2.4	Output power dynamics.....	60
6.2.4.1	Inner loop power control.....	60
6.2.4.2	Power control steps.....	60
6.2.4.2.1	Minimum requirement.....	60
6.2.4.3	Power control dynamic range.....	60
6.2.4.3.1	Minimum requirement.....	60
6.2.4.4	Minimum transmit power.....	60
6.2.4.4.1	Minimum requirement.....	60
6.2.4.5	Primary CCPCH power.....	60
6.2.5	Transmit ON/OFF power.....	61
6.2.5.1	Transmit OFF power.....	61
6.2.5.1.1	Minimum Requirement.....	61
6.2.5.2	Transmit ON/OFF Time mask.....	61
6.2.6	Output RF spectrum emissions.....	61
6.2.6.1	Occupied bandwidth.....	61
6.2.6.2	Out of band emission.....	62
6.2.6.2.1	Spectrum emission mask.....	62
	Frequency offset from carrier Δf	62
6.2.6.2.2	Adjacent Channel Leakage power Ratio(ACLR).....	62
6.2.6.3	Spurious emissions.....	62
6.2.6.3.1	Mandatory Requirements.....	62
6.2.6.3.1.1	Spurious emissions (Category A).....	63
6.2.6.3.1.2	Spurious emissions (Category B).....	63
6.2.6.3.1.2.1	Minimum Requirement.....	63
6.2.6.3.2	Co-existence with GSM 900.....	64
6.2.6.3.2.1	Operation in the same geographic area.....	64
6.2.6.3.2.1.1	Minimum requirement.....	64
6.2.6.3.2.2	Co-located base stations.....	64
6.2.6.3.2.2.1	Minimum requirement.....	64
6.2.6.3.3	Co-existence with DCS 1800.....	64
6.2.6.3.3.1	Operation in the same geographic area.....	64
6.2.6.3.3.1.1	Minimum requirement.....	64
6.2.6.3.3.2	Co-located base stations.....	64
6.2.6.3.3.2.1	Minimum requirement.....	64
6.2.6.3.4	Co-existence with UTRA FDD.....	64
6.2.6.3.4.1	Operation in the same geographic area.....	64
6.2.6.3.4.1.1	Minimum requirement.....	64
6.2.6.3.4.2	Co-located base stations.....	64
6.2.6.3.4.2.1	Minimum requirement.....	65
6.2.7	Transmit intermodulation.....	65
6.2.7.1	Minimum requirement.....	65
6.2.8	Transmit modulation.....	65
6.2.8.1	Transmit pulse shape filter.....	65

6.2.8.2	Modulation Accuracy.....	66
6.2.8.2.1	Minimum Requirement.....	66
6.2.8.3	Peak Code Domain Error.....	66
6.2.8.3.1	Minimum Requirement.....	66
6.3	Receiver characteristics.....	66
6.3.1	General.....	66
6.3.2	Reference sensitivity level.....	66
6.3.2.1	Minimum Requirement.....	67
6.3.2.2	Maximum Frequency Deviation for Receiver Performance.....	68
6.3.3	Dynamic range.....	68
6.3.3.1	Minimum requirement.....	69
6.3.4	Adjacent Channel Selectivity (ACS).....	69
6.3.4.1	Minimum Requirement.....	69
6.3.5	Blocking characteristics.....	70
6.3.5.1	Minimum Requirements.....	70
6.3.6	Intermodulation characteristics.....	71
6.3.7	Spurious emissions.....	71
6.3.7.1	Minimum Requirement.....	71
6.4	Performance requirement.....	72
6.4.1	General	72
6.4.2	Demodulation in static propagation conditions.....	73
6.4.2.1	Demodulation of DCH.....	73
6.4.2.2.1.1	Minimum requirement.....	73
6.4.3	Demodulation of DCH in multipath fading conditions	74
6.4.3.1	Multipath fading Case 1.....	74
6.4.3.1.1	Minimum requirement.....	74
6.4.3.2	Multipath fading Case 2.....	74
6.4.3.2.1	Minimum requirement.....	75
6.4.3.3	Multipath fading Case 3.....	75
6.4.3.3.1	Minimum requirement.....	75
Annex 6.A (normative): Measurement Channels.....		77
6.A.1:	General.....	77
6.A.2:	Reference Measurement Channel;.....	77
6.A.2.1	UL reference measurement channel (12.2 kbps).....	77
6.A.2.2	UL reference measurement channel (64 kbps).....	78
6.A.2.3	UL reference measurement channel (144 kbps).....	79
6.A.2.4	UL reference measurement channel (384 kbps).....	81
Annex 6.B (normative): Propagation conditions.....		83
6.B.1	Static Propagation conditions.....	83
6.B.2	multi-path fading Propagation conditions.....	83
7 Base Station EMC.....		84
7.1	Test conditions.....	84
7.1.1	General.....	84

7.1.2	Arrangements for establishing a communication link	84
7.1.3	Narrow band responses on receivers.....	84
7.2	Performance assessment.....	85
7.2.1	General	85
7.2.2	Ancillary equipment	85
7.3	Performance Criteria	85
7.3.1	Performance criteria A for continuous phenomena for BS	85
7.3.2	Performance criteria B for transient phenomena for BS.....	85
7.3.3	Performance criteria C for BS	85
7.3.4	Performance criteria A for continuous phenomena for Ancillary equipment	85
7.3.5	Performance criteria B for transient phenomena for Ancillary equipment	85
7.3.6	Performance criteria C for Ancillary equipment.....	85
7.4	Applicability overview	86
7.4.1	Emission	86
7.4.2	Immunity	86
Annex 7.A (normative):	Methods of measurement.....	86
7.A.1:	Emission	86
7.A.1.1	Methods of measurement and limits for EMC emissions	86
7.A.1.2	Test configurations.....	86
7.A.1.3	Radiated spurious emission from Base station and ancillary equipment.....	86
7.A.1.3.1	Radiated spurious emission, Base stations	86
7.A.1.3.1.1	Definition 86	
7.A.1.3.1.2	Test method 86	
7.A.1.3.1.3	Test configurations	87
7.A.1.3.2	Radiated spurious emission, Ancillary equipment	87
7.A.1.4	Conducted emission DC power input/output port	87
7.A.1.5	Conducted emissions, AC mains power input/output port	87
7.A.1.6	Harmonic Current emissions (AC mains input port).....	87
7.A.1.7	Voltage fluctuations and flicker (AC mains input port)	87
7.A.2:	Immunity	87
8	BS conformance testing.....	88
8.1	Frequency bands and channel arrangement.....	88
8.1.1	General	88
8.1.2	Frequency bands	88
8.1.3	TX–RX frequency separation	88
8.1.4	Channel arrangement	88
8.1.4.1	Channel spacing	88
8.1.4.1.1	Background88	
8.1.4.1.2	Channel spacing	89
8.1.4.2	Channel raster	89
8.1.4.3	Channel number	89
8.2	General test conditions and declarations	89
8.2.1	Base station classes.....	89
8.2.2	Output power and determination of power class	89

8.2.3	Specified frequency range	89
8.2.4	Spectrum emission mask	89
8.2.5	Adjacent Channel Leakage power Ratio (ACLR)	89
8.2.6	Tx spurious emissions.....	89
8.2.6.1	Category of spurious emissions limit	89
8.2.6.2	Co-existence with GSM	90
8.2.6.3	Co-existence with DCS 1800	90
8.2.6.4	Co-existence with UTRA FDD	90
8.2.7	Blocking characteristics.....	90
8.2.8	Test environments.....	90
8.2.9	Interpretation of measurement results.....	90
8.2.10	Selection of configurations for testing.....	90
8.2.11	BS Configurations	90
8.2.12	Overview of the conformance test requirements	90
8.2.13	Format and interpretation of tests	91
8.3	Transmitter characteristics	91
8.3.1	General	91
8.3.2	Maximum output power	91
8.3.2.1	Definition and applicability.....	91
8.3.2.2	Conformance requirements	91
8.3.2.3	Test purpose	91
8.3.2.4	Method of test	91
8.3.2.4.1	Initial conditions.....	91
8.3.2.4.2	Procedure 92	
8.3.2.5	Test requirements	92
8.3.3	Frequency stability.....	92
8.3.3.1	Definition and applicability.....	92
8.3.3.2	Conformance requirement.....	92
8.3.3.3	Test purpose	92
8.3.3.4	Method of test	92
8.3.3.4.1	Initial conditions.....	92
8.3.3.4.2	Procedure 93	
8.3.3.5	Test requirement	93
8.3.4	Output power dynamics.....	93
8.3.4.1	Inner loop power control.....	93
8.3.4.2	Power control steps	93
8.3.4.2.1	Definition and applicability.....	93
8.3.4.2.2	Conformance requirements	94
8.3.4.2.3	Test purpose	94
8.3.4.2.4	Method of test.....	94
8.3.4.2.4.1	Initial conditions	94
8.3.4.2.4.2	Procedure 94	
8.3.4.2.5	Test requirements	95
8.3.4.3	Power control dynamic range.....	95

8.3.4.3.1	Definition and applicability	95
8.3.4.3.2	Conformance requirements	95
8.3.4.3.3	Test purpose	95
8.3.4.3.4	Method of test.....	95
8.3.4.3.4.1	Initial conditions	95
8.3.4.3.4.2	Procedure 96	
8.3.4.3.5	Test requirements	96
8.3.4.4	Minimum transmit power.....	96
8.3.4.4.1	Definition and applicability.....	96
8.3.4.4.2	Conformance requirements	97
8.3.4.4.3	Test purpose	97
8.3.4.4.4	Method of test.....	97
8.3.4.4.4.1	Initial conditions	97
8.3.4.4.4.2	Procedure 97	
8.3.4.4.5	Test requirements	97
8.3.4.5	Primary CCPCCH power.....	98
8.3.4.5.1	Definition and applicability.....	98
8.3.4.5.2	Conformance requirement	98
8.3.4.5.3	Test purpose	98
8.3.4.5.4	Method of test.....	98
8.3.4.5.4.1	Initial conditions	98
8.3.4.5.4.2	Procedure 98	
8.3.4.5.5	Test requirement.....	99
8.3.5	Transmit OFF power.....	99
8.3.5.1	Definition and applicability.....	99
8.3.5.2	Conformance requirements	99
8.3.5.3	Test purpose	99
8.3.5.4	Method of test	99
8.3.5.4.1	Initial conditions.....	99
8.3.5.4.2	Procedure 100	
8.3.5.5	Test requirements	100
8.3.6	Output RF spectrum emissions.....	100
8.3.6.1	Occupied bandwidth	100
8.3.6.1.1	Definition and applicability.....	100
8.3.6.1.2	Conformance requirements	100
8.3.6.1.3	Test purpose	100
8.3.6.1.4	Method of test.....	100
8.3.6.1.4.1	Initial conditions	100
8.3.6.1.4.2	Procedure 101	
8.3.6.1.5	Test requirements	101
8.3.6.2	Out of band emission	102
8.3.6.2.1	Spectrum emission mask	102
8.3.6.2.1.1	Definition and applicability	102
8.3.6.2.1.2	Conformance requirements.....	102

8.3.6.2.1.3	Test purpose	102
8.3.6.2.1.4	Method of test	102
8.3.6.2.1.4.1	Initial conditions	102
8.3.6.2.1.4.2	Procedure	103
8.3.6.2.1.5	Test requirements	103
8.3.6.2.2	Adjacent Channel Leakage power Ratio (ACLR)	103
8.3.6.2.2.1	Definition and applicability	103
8.3.6.2.2.2	Conformance requirements	103
8.3.6.2.2.3	Test purpose	103
8.3.6.2.2.4	Method of test	103
8.3.6.2.2.4.1	Initial conditions	103
8.3.6.2.2.4.2	Procedure	104
8.3.6.2.2.5	Test requirements	104
8.3.6.3	Spurious emissions	105
8.3.6.3.1	Definition and applicability	105
8.3.6.3.2	Conformance requirements	105
8.3.6.3.3	Test purpose	105
8.3.6.3.4	Method of test	105
8.3.6.3.4.1	Initial conditions	105
8.3.6.3.4.2	Procedure	106
8.3.6.3.5	Test requirements	106
8.3.7	Transmit intermodulation	106
8.3.7.1	Definition and applicability	106
8.3.7.2	Conformance requirements	107
8.3.7.3	Test purpose	107
8.3.7.4	Method of test	107
8.3.7.4.1	Initial conditions	107
8.3.7.4.2	Procedure	107
8.3.7.5	Test requirements	108
8.3.8	Transmit Modulation	108
8.3.8.1	Modulation accuracy	108
8.3.8.1.1	Definition and applicability	108
8.3.8.1.2	Conformance requirements	109
8.3.8.1.3	Test purpose	109
8.3.8.1.4	Method of test	109
8.3.8.1.4.1	Initial conditions	109
8.3.8.1.4.2	Procedure	109
8.3.8.1.5	Test requirements	109
8.3.8.2	Peak code domain error	109
8.3.8.2.1	Definition and applicability	109
8.3.8.2.2	Conformance requirements	110
8.3.8.2.3	Test purpose	110
8.3.8.2.4	Method of test	110
8.3.8.2.4.1	Initial conditions	110

8.3.8.2.4.2	Procedure	110
8.3.8.2.5	Test requirements	110
8.4	Receiver characteristics	111
8.4.1	General	111
8.4.2	Reference sensitivity level	111
8.4.2.1	Definition and applicability	111
8.4.2.2	Conformance requirements	111
8.4.2.3	Test purpose	111
8.4.2.4	Method of test	111
8.4.2.4.1	Initial conditions	111
8.4.2.4.2	Procedure	111
8.4.2.5	Test requirements	111
8.4.3	Dynamic range	112
8.4.3.1	Definition and applicability	112
8.4.3.2	Conformance requirements	112
8.4.3.3	Test purpose	112
8.4.3.4	Method of test	112
8.4.3.4.1	Initial conditions	112
8.4.3.4.2	Procedure	112
8.4.3.5	Test requirement	112
8.4.4	Adjacent Channel Selectivity (ACS)	112
8.4.4.1	Definition and applicability	112
8.4.4.2	Conformance requirements	112
8.4.4.3	Test purpose	113
8.4.4.4	Method of test	113
8.4.4.4.1	Initial conditions	113
8.4.4.4.2	Procedure	113
8.4.4.5	Test requirements	113
8.4.5	Blocking characteristics	113
8.4.5.1	Definition and applicability	113
8.4.5.2	Conformance requirements	114
8.4.5.3	Test purpose	114
8.4.5.4	Method of test	114
8.4.5.4.1	Initial conditions	114
8.4.5.4.2	Procedure	114
8.4.5.5	Test requirements	115
8.4.6	Intermodulation characteristics	115
8.4.6.1	Definition and applicability	115
8.4.6.2	Conformance requirements	115
8.4.6.3	Test purpose	115
8.4.6.4	Method of test	115
8.4.6.4.1	Initial conditions	115
8.4.6.4.2	Procedure	116
8.4.6.5	Test requirements	116

8.4.7	Spurious emissions	116
8.4.7.1	Definition and applicability.....	116
8.4.7.2	Conformance requirements	116
8.4.7.3	Test requirements	116
8.4.7.4	Method of test	116
8.4.7.4.1	Initial conditions	116
8.4.7.4.2	Procedure 117	
8.4.7.5	Test requirements	117
8.5	Performance requirements.....	118
8.5.1	General	118
8.5.2.	Demodulation in static propagation conditions	118
8.5.2.1	Demodulation of DCH	118
8.5.2.1.1	Definition and applicability.....	118
8.5.2.1.2	Conformance requirements	118
8.5.2.1.3	Test purpose	119
8.5.2.1.4	Method of test.....	119
8.5.2.1.4.1	Initial conditions	119
8.5.2.1.4.2	Procedure 119	
8.5.2.1.5	Test requirements	120
8.5.3.	Demodulation of DCH in multipath fading conditions.....	120
8.5.3.1	Multipath fading Case 1	120
8.5.3.1.1	Definition and applicability.....	120
8.5.3.1.2	Conformance requirements	121
8.5.3.1.3	Test purpose	121
8.5.3.1.4	Method of test.....	121
8.5.3.1.4.1	Initial conditions	121
8.5.3.1.4.2	Procedure 122	
8.5.3.1.5	Test requirements	122
8.5.3.2	Multipath fading Case 2	123
8.5.3.2.1	Definition and applicability	123
8.5.3.2.2	Conformance requirements	123
8.5.3.2.3	Test purpose	123
8.5.3.2.4	Method of test.....	124
8.5.3.2.4.1	Initial conditions	124
8.5.3.2.4.2	Procedure 124	
8.5.3.2.5	Test requirements	125
8.5.3.3	Multipath fading Case 3	125
8.5.3.3.1	Definition and applicability	125
8.5.3.3.2	Conformance requirements	125
8.5.3.3.3	Test purpose	126
8.5.3.3.4	Method of test.....	126
8.5.3.3.4.1	Initial conditions	126
8.5.3.3.4.2	Procedure 127	
8.5.3.3.5	Test requirements	127

Annex 8.A (normative): Measurement Channels	128
8.A.1: General	128
8.A.2: Reference measurement channel	128
8.A.2.1 UL reference measurement channel (12.2 kbps).....	128
8.A.2.2 UL reference measurement channel (64 kbps).....	129
8.A.2.3 UL reference measurement channel (144 kbps).....	130
8.A.2.4 UL reference measurement channel (384 kbps).....	132
Annex 8.B (normative): Propagation conditions	134
8.B.1 Static Propagation conditions	134
8.B.2 multi-path fading Propagation conditions.....	134
Annex 8.C (normative): Global in-channel Tx test	134
8.C.1: General	134
8.C.2: Definition of the process.....	135
8.C.2.1 Basic principle	135
8.C.2.2 Output signal of the Tx under test	135
8.C.2.3 Reference signal	135
8.C.2.4 Classification of measurement results	135
8.C.2.5 Process definition to achieve results of type “deviation”.....	135
8.C.2.6 Process definition to achieve results of type “residual”	135
8.C.2.6.1 Error Vector Magnitude (EVM)	135
8.C.2.6.2 Peak Code Domain Error (PCDE).....	135
8.C.3: Applications.....	135
8.C.4 Notes	136
9 RF System scenarios.....	136
9.1 General	136
9.2 Methodology for coexistence studies 1.28Mcps TDD / FDD	138
9.3 Methodology for coexistence studies 1.28Mcps TDD / 3.84Mcps TDD	138
9.4 Methodology for coexistence studies 1.28Mcps TDD / 1.28Mcps TDD	138
9.5 Results, implementation issues and recommendations.....	138
9.5.1 1.28Mcps TDD /FDD	138
9.5.2 1.28Mcps TDD / 3.84Mcps TDD	138
9.5.3 1.28Mcps TDD / 1.28Mcps TDD	138
9.6 Information and General purpose materials	138
9.6.1 CDMA Definitions and Equations.....	138
9.6.1.1 CDMA-related definitions.....	138
9.6.1.2 CDMA equations.....	139
9.7 Link Level performances.....	139
9.7.1 Simulation results for 1,28Mcps TDD performace.....	139
9.7.1.1 Simulation assumptions	139
9.7.1.1.1 Simulation chain.....	139
9.7.1.1.1.1 Downlink 139	
9.7.1.1.1.2 Uplink 140	
9.7.1.1.2 Simulation Assumptions.....	143

9.7.1.1.2.1	General	143
9.7.1.1.2.2	Additional downlink parameters.....	143
9.7.1.1.2.3	Additional uplink parameters.....	144
9.7.1.2	Simulation results.....	144
9.7.1.2.1	12.2kps service	144
9.7.1.2.1.1	Graphical Presentation of 12.2 kbps service UL Simulation Results.....	144
9.7.1.2.1.2	Graphical Presentation of 12.2 kbps service DL Simulation Results.....	146
9.7.1.2.2	64kps Service	147
9.7.1.2.2.1	Graphical Presentation of 64 kbps service UL Simulation Results.....	147
9.7.1.2.2.2	Graphical Presentation of 64 kbps service DL Simulation Results.....	149
9.7.2	1,28Mcps TDD and FDD link level simulation.....	150
	Annex: The key physical layer parameters for low chip rate TDD option.....	151
13	History	155

Foreword

This Technical Report has been produced by the 3GPP.

The contents of the present document are subject to continuing work within the TSG and may change following formal TSG approval. Should the TSG modify the contents of this TS, it will be re-released by the TSG with an identifying change of release date and an increase in version number as follows:

Version 3.y.z

where:

- x the first digit:
 - 1 presented to TSG for information;
 - 2 presented to TSG for approval;
 - 3 Indicates TSG approved document under change control.
- y the second digit is incremented for all changes of substance, i.e. technical enhancements, corrections, updates, etc.
- z the third digit is incremented when editorial only changes have been incorporated in the specification.

1 Scope

This technical Report identifies the RF Radio Transmission/Reception and Radio Resource Management requirements for the 1.28Mcps UTRA TDD option, including the commonalties and differences. Furthermore, the impact on the RF system Scenarios and BS conformance testing is also identified.

2 References

The following documents contain provisions which, through reference in this text, constitute provisions of the present document.

- References are either specific (identified by date of publication, edition number, version number, etc.) or non-specific.
- For a specific reference, subsequent revisions do not apply.
- For a non-specific reference, the latest version applies.
- A non-specific reference to an TS shall also be taken to refer to later versions published as an EN with the same number.

- [1] 25.102 UE Radio transmission and reception (TDD)
- [3] 25.105 BS Radio transmission and reception (TDD)
- [4] 25.123 RF parameters in support of RRM (TDD)
- [5] 25.142 Base Station conformance testing (TDD)
- [6] 25.113 Base Station EMC
- [7] 25.942 RF System scenarios
- [8] 25.922 RRM Strategies

3 Abbreviations

For the purposes of the present document, the following abbreviations apply:

4 RF Parameters in Support of Radio Resource Management

4.1 Idle Mode Tasks

4.1.1 Introduction

4.1.2 RF Cell Selection Scenario

4.1.2.1 Requirements for Cell Selection single carrier single cell case

4.1.2.2 Requirements for Cell Selection single carrier multi cell case

RF Cell Re-Selection Scenario

4.1.3.1 Requirements for Cell Re-Selection single carrier multi cell case

4.1.3.2 Requirements for UTRAN to GSM Cell Re-Selection

4.2 RRC Connection mobility

4.2.1 Handover

4.2.1.1 Introduction

The handover process should be implemented in both the UE and UTRAN. The UE measurements and which radio links the UE shall use is controlled by UTRAN with RRC signalling.

For the handover preparation the UE receives from the UTRAN a list of cells (e.g. 1.28Mcps TDD, or GSM), which the UE shall monitor (see 'monitored set' in 3GPP RAN TS 25.331 'RRC Protocol Specification') in its idle timeslots.

[Editor note]: The handover from 1.28Mcps TDD to FDD will be given out in short term. And the handover from 1.28Mcps TDD to 3.84Mcps TDD would be as a future option

At the beginning of the measurement process the UE shall find synchronization to the cell to measure using the synchronization channel (DwPTS). This is described under 'cell search' in 3GPP RAN TR 25.928 ' if the monitored cell is a 1.28Mcps TDD cell.

For a TDD cell to monitor after this procedure the exact timing of the midamble of the P-CCPCH is known and the measurements can be performed. Depending on the UE implementation and if timing information about the cell to monitor is available, the UE may perform the measurements on the P-CCPCH directly without prior DwPTS synchronization.

4.2.1.2 1.28Mcps TDD/1.28Mcps TDD Handover

For the search for other cells the UE is provided by a handover monitoring set by the UTRAN.

The handover procedure is initiated from UTRAN with an active set update message.

For the requirements in this section, all cells are assumed to be unsynchronized.

4.2.1.2.1 Requirements

4.2.1.2.1.1 Maximum number of cells to be monitored

The UE shall be capable of measuring at least [6] cells given in a measurement control message(s).

4.2.1.2.1.2 Measurement reporting delay

The measurement reporting delay is defined as the time from when a report is triggered at the physical layer according to the event or periodic mechanism set to trigger the measurement report, until the UE starts to transmit the measurement report over the Uu interface. This measurement reporting delay excludes the delay uncertainty resulting when the measurement report is inserted to the TTI of the uplink DCCH. The delay uncertainty is twice the TTI of the uplink DCCH.

The DL reference measurement channel 12.2 kbps shall be used.

4.2.1.2.1.2.1 Correct reporting of neighbours in AWGN propagation condition

This test will derive that the terminal makes correct reporting of an event Cell 1 is the active cell, Cell 2 is a neighbour cell on the used frequency. The power level on Cell 1 is kept constant and the power level of Cell 2 is changed using 'change of best cell event' as illustrated in Figure1. Hysteresis, absolute Threshold and Time to Trigger values are given in the table below and they are signaled from test device. In the measurement control information it is indicated to the UE that event-triggered reporting with Event 1G shall be used. P-CCPCH RSCP of the best cell has to be reported together with Event 1G reporting. New measurement control information, which defines neighbour cells etc., is always sent before the event starts.

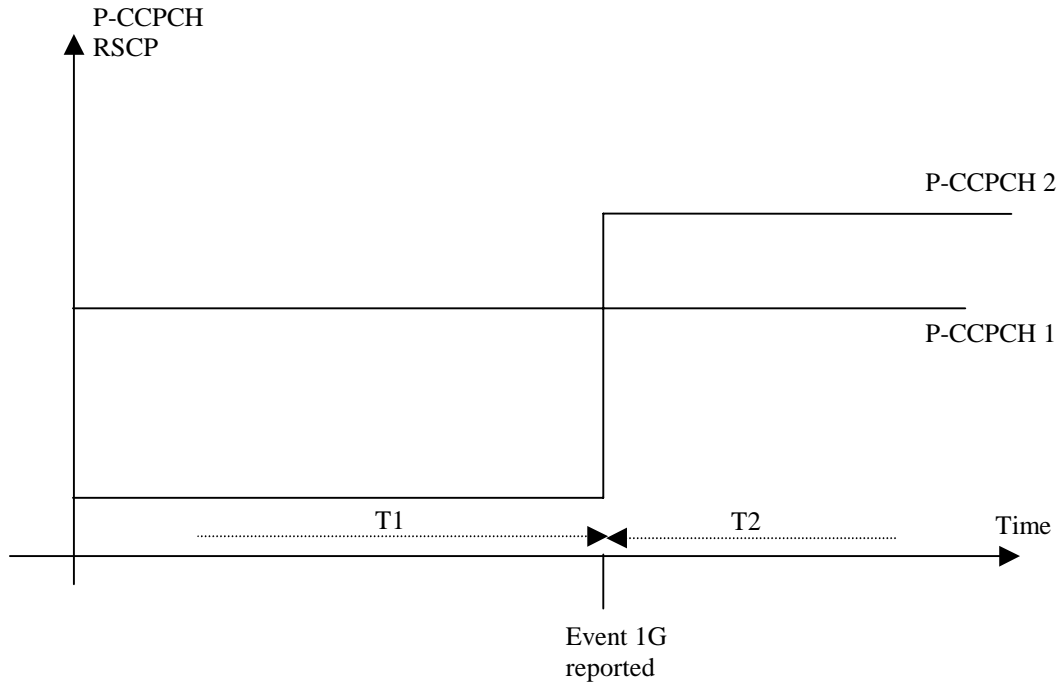

Figure 1: Illustration of parameters for handover measurement reporting test case

Table 4.2.1.2.-1

Parameter	Unit	Cell 1		Cell 2	
		T1	T2	T1	T2
<i>Timeslot Number</i>		0		0	
<i>UTRA RF Channel Number</i>		Channel 1		Channel 1	
<i>PCCPCH_Ec/Ior</i>	dB	-3	-3	-3	-3
<i>SCH_offset</i>		0	0	15	15
<i>DCH_Ec/Ior</i>		[]	[]	[]	[]
<i>OCNS</i>		-3	-3	-3	-3
\hat{I}_{or}/I_{oc}	dB	3	3	-Infinity	5
I_{oc}	dBm/1.28 MHz	-70			
<i>PCCPCH_RSCP</i>	dB	-70	-70	-Infinity	-68
Absolute Threshold (SIR)	dB	[]			
Hysteresis	dB	[]			
Time to Trigger	msec	[]			
Propagation Condition		AWGN			

[Explanation difference:]

In 1.28Mcps TDD the PICH is mapped onto P-CCPCH as describe in TR25.928. So the PICH-Ec/Ior is no longer used. The function of the SCH is achieved by DwPTS in 1.28Mcps TDD and it is allocated to a dedicated timeslot. And the P-CCPCH is always mapped onto time slot 0, so time slot 8 is not considered in 1.28Mcps TDD.

4.2.1.2.1.2.1.1 Requirements

The measurement reporting delay shall be less than [5] seconds in 90% of the cases.

All the reported entities shall be within the requirements.

4.2.1.2.1.3 Handover Delay

The handover delay is defined as the time from when the UE receives the handover command message from UTRAN, until the UE successfully uses the entire set of radio links stated in that message for power control.

The handover delay is stated in the table below. There is different requirement on the handover delay depending on if the cell has been within the monitored set of cells for the last [FFS] [s] or not.

Table 4.2.1.2-2

Number of new cells present in the handover command message	Maximum update delay [ms]	
	Cells within monitored set	Cells outside monitored set
1-6...		

4.2.1.3 Handover 3G to 2G

In the early days of UMTS deployment it can be anticipated that the service area will not be as contiguous and extensive as existing second generation systems. It is also anticipated that UMTS network will be an overlay on the 2nd generation network and utilise the latter, in the minimum case, as a fall back to ensure continuity of service and maintain a good QoS as perceived by the user.

4.2.1.3.1 Handover to GSM

This section presents some of the important aspects of GSM handover required to be performed by the UE. For the full specifications reference should be made the GSM recommendations.

The underlying requirement is to ensure continuity of service to the UMTS user. The handover requirements for 3G to GSM should be comparable to GSM to GSM handover requirements.

The MS (GSM terminology) shall be able to monitor up to [32] carriers.

The MS shall be able synchronize to [6] carriers

The MS shall be able to report back to the network on the [6] strongest cells with correctly identified BSIC.

The MS shall be able to perform this task at levels down to the reference sensitivity level or reference interference levels as specified in GSM 05.05.

The MS shall demodulate the SCH on the BCCH carrier of each surrounding cell and decode the BSIC as often as possible, and as a minimum at least once every [10 seconds].

4.2.2 Radio Link Management

4.2.2.1 Link adaptation

4.2.3 Cell Update

4.2.4 URA Update

4.3 RRC Connection Control

4.3.1 Radio Access Bearer Control

4.4 Dynamic Channel Allocation

4.4.1 Introduction

4.4.2 Implementation Requirements

4.4.3 Number of timeslots to be measured

4.4.4 Measurement reporting delay

4.5 Timing characteristics

4.5.1 Timing Advance (TA) Requirements for 1.28Mcps TDD option)

To update timing advance (synchronisation shift) of a moving UE the UTRAN measures 'RX Timing deviation'. The measurements are reported to higher layers and physical layer, where timing advance values are calculated and signaled to the UE. The measurement for timing advance of 1.28Mcps TDD is same as that is defined in TS25.225 "Physical Layer Measurements (TDD)" except that the range/mapping requirement, the requirements on the measurement is specified

bellow. The UE shall adjust the timing of its transmissions within $\pm 1/8$ chip of the signaled timing advance value.

4.5.1.1 RX Timing Deviation

Definition	'RX Timing Deviation' is the time difference $TRX_{dev} = TTS - TRX_{path}$ in chips, with TRX_{path} : time of the reception in the Node B of the first significant uplink path to be used in the detection process TTS : time of the beginning of the respective slot according to the Node B internal Timing
Range/mapping	RX Timing Deviation is given with a resolution of $[1/8]$ chip with the range $[-128;128]$ chip (11 bit) in random access procedure. RX Timing Deviation is given with a resolution of $[1/8]$ chip with the range $[-1/8; 1/8]$ chip (2 bit) in DPCH. RX Timing Deviation cell shall be reported in the unit RX_TIME_DEV , where $RX_TIME_DEV: (N * 1/8 - 128) \text{ chips} \leq RX \text{ Timing Deviation} < ((N+1) * 1/8 - 128) \text{ chips}$ With $N= 0, 1, 2, \dots, 2047$

NOTE: This measurement can be used for timing advance (synchronisation shift) calculation for uplink synchronisation or location services.

[Explanation difference:]

In 3.84Mcps TDD the 'RX Timing Deviation' measurement is only needed to report to the higher layer for timing advance calculation or location services. It does not need to measure this value continuously.

While in 1.28Mcps TDD this measurement is not only reported to higher layer, but also severed as a physical signal ('Synchronisation Shift' or 'SS') to keep uplink synchronisation. It needs to be refreshed every 5ms (every sub-frame). The resolution requirement is $1/8$ chip as described in section 10.2 'Timing Advance' of TR25.928.

Because SS is severed as a physical layer signal in 1.28Mcps TDD, it needs to consider how to map this value onto data burst. When in random access procedure the SS control step should have a large range to quickly establish the uplink synchronisation. While in normal working procedure to maintain the uplink synchronisation it should use as little bits as possible to reduce the affection to the DPCH capacity. These consideration are described in section 10.2 'Timing Advance' and section 8.2.2 'Coding of Synchronisation Shift' of TR25.928.

4.6 Measurements Performance Requirements

One of the key services provided by the physical layer is the measurement of various quantities which are used to trigger or perform a multitude of functions. Both the UE and the UTRAN are required to perform a variety of measurements. The complete list of measurements is specified in TSG RAN WG2 S25.302 "Services Provided by Physical Layer". The physical layer measurements for TDD are described and defined in TSG RAN WG1 TS25.225 "Physical layer – Measurements (TDD)". In this section for 1.28Mcps TDD, per each measurement the relevant requirements on performance in terms of accuracy are reported.

Unless explicitly stated,

- Reported measurements shall be within defined range in 90 % of the cases.
- Measurement channel is 12.2 kbps as defined in annex 5.A, section 5.A.2. This measurement channel is used both in active cell and cells to be measured.

- Physical channels used as defined in TR25.928.
- All requirements are defined when UE is in a CELL_DCH or CELL_FACH stage. The difference between modes are the reporting delay. Some of the measurements are not requested to be reported in both stages.
- Cell 1 is the active cell, if not otherwise stated
- Single task reporting.
- Power control is active.

4.6.1 Measurements Performance for UE for 1.28Mcps TDD

option

4.6.1.1 Performance for UE Measurements in Downlink (RX)

If not otherwise stated, the test parameters in table 4.6-1-1 should be applied for UE RX measurements requirements in this section.

Table 4.6-1-1 Intra frequency test parameters for UE RX Measurements

Parameter	Unit	Cell 1	Cell 2
<i>UTRA RF Channel number</i>		Channel 1	Channel 1
<i>Timeslot</i>		0	0
<i>P-CCPCH Ec/Ior</i>	dB	-3	-3
<i>SCH Ec/Ior</i>	dB	[]	[]
<i>DPCH_Ec/Ior</i>	dB	[]	[]
<i>OCNS</i>	dB	[]	[]
<i>I_{or}/I_{oc}</i>	dB	[]	[]
<i>I_{oc}</i>	dBm/ 1.28 MHz	-70	-70
<i>Range 1: I_o</i>	DBm	-94..-70	-94..-70
<i>Range 2: I_o</i>		-94..-50	-94..-50
<i>Propagation condition</i>	-	AWGN	AWGN

[Explanation difference:]

In 1.28Mcps TDD the PICH is mapped onto P-CCPCH as describe in TR25.928. So the PICH-Ec/Ior is no longer used.

4.6.1.1.1 COMMON CONTROL PHYSICAL CHANNEL MEASUREMENTS

These measurements consider *P-CCPCH RSCP* measurements for 1.28Mcps TDD cells.

4.6.1.1.1.1 P-CCPCH RSCP (1.28Mcps TDD)

4.6.1.1.1.1.1 Intra frequency test parameters

In this case all cells are in the same frequency. The table 4.6-1-2 and notes 4 define the limits of signal strengths and code powers, where the requirement is applicable.

Table 4.6-1-2 P-CCPCH RSCP intra frequency test parameters

Parameter	Unit	Cell 1	Cell 2
<i>UTRA RF Channel number</i>		Channel 1	Channel 1

<i>Timeslot</i>		0	0
<i>P-CCPCH Ec/Ior</i>	dB	-3	-3
<i>OCNS</i>	dB	[]	[]
$\hat{I}or/Ioc$	dB	[]	[]
<i>Ioc</i>	dBm/ 1.28 MHz	Note 4	Note 4
<i>Range 1: Io</i>	dBm	-94..-70	-94..-70
<i>Range 2: Io</i>		-94..-50	-94..-50
<i>Propagation condition</i>	-	AWGN	

Note 1: $P-CCPCH_RSCP_{1,2} \geq -[102]$ dBm.

Note 2: $|P-CCPCH_RSCP1 - PCCPCH_RSCP2| \leq 20$ dB.

Note 3: $|Io - P-CCPCH_Ec/Ior| \leq [20]$ dB.

Note 4: *Ioc* level shall be adjusted according the total signal power *Io* at receiver input and the geometry factor $\hat{I}or/Ioc$.

4.6.1.1.1.1.2 Absolute accuracy requirements

The absolute accuracy of P-CCPCH RSCP is defined as measured one code power after de-spreading. In this test only Cell 1 in table 4.6-3 is present.

Table 4.6-3: P-CCPCH_RSCP Intra frequency absolute accuracy

Parameter	Value	Range	Accuracy	
			Normal conditions	Extreme conditions
<i>P-CCPCH_RSCP</i>	dB	1	± 6	± 9
	dB	2	± 8	± 11

4.6.1.1.1.1.3 Relative accuracy requirements

The relative accuracy of P-CCPCH RSCP is defined as measured code powers from active cell and one or more cells after de-spreading. The reported value is relative to active cell value. In this test Cell 1 and 2 in table 1 are present.

Table 4.6-4 P-CCPCH_RSCP Intra frequency relative accuracy

Parameter	Unit	Accuracy	
		Normal conditions	Extreme conditions
<i>P-CCPCH_RSCP</i>	dB	± 3	± 3

4.6.1.1.1.1.4 Range/mapping

Range/mapping	P-CCPCH RSCP is given with a resolution of 1 dB with the range [-115,-25] dBm. P-CCPCH RSCP shall be reported in the unit P-CCPCH_RSCP_LEV where:		
			P-CCPCH_RSCP < -115dBm
	P-CCPCH_RSCP_LEV_00:		
	P-CCPCH_RSCP_LEV_01:	-115dBm ≤	P-CCPCH_RSCP < -114dBm
	P-CCPCH_RSCP_LEV_02:	-114dBm ≤	P-CCPCH_RSCP < -113dBm
	...		
	P-CCPCH_RSCP_LEV_89:	-27dBm ≤	P-CCPCH_RSCP < -26dBm
	P-CCPCH_RSCP_LEV_90:	-26dBm ≤	P-CCPCH_RSCP < -25dBm
	P-CCPCH_RSCP_LEV_91:	-25dBm ≤	P-CCPCH_RSCP

4.6.1.1.3 UTRA carrier RSSI

NOTE: The purpose of measurement is for Inter-frequency handover evaluation.

4.6.1.1.3.1 Test parameters for requirement

The table 4.6-1-3 and notes 1,2 define the limits of signal strengths, where the requirement is applicable.

Table 4.6-1-3 UTRA carrier RSSI Inter frequency test parameters

Parameter	Unit	Cell 1	Cell 2
<i>UTRA RF Channel number</i>	-	Channel 1	Channel 2
\hat{I}_{or}/I_{oc}	dB	-1	-1
<i>I_{oc}</i>	dBm/1.28 MHz	Note 2	Note 2
<i>Range 1: I_o</i>	dBm/ 1.28MHz	-94..-70	-94..-70
<i>Range 2: I_o</i>		-94..-50	-94..-50
<i>Propagation condition</i>	-	AWGN	

NOTE 1: For relative accuracy requirement / $Channel\ 1_{I_o} - Channel\ 2_{I_o}$ / <20dB

NOTE 2: *I_{oc}* level shall be adjusted according the total signal power *I_o* at receiver input and the geometry factor \hat{I}_{or}/I_{oc} .

4.6.1.1.3.2 Absolute accuracy requirement

Absolute accuracy case only one carrier is applied (Cell 1).

Table 4.6-1-4: UTRA carrier RSSI Inter frequency absolute accuracy

Parameter	Value	Range	Accuracy	
			Normal conditions	Extreme conditions
<i>UTRA Carrier RSSI</i>	dB	1	± 4	± 7
	dB	2	± 6	± 9

4.6.1.1.3.3 Relative accuracy requirement

Relative accuracy requirement is defined as active cell frequency UTRAN RSSI compared to measured other frequency UTRAN RSSI level. In relative accuracy test case both carriers in table 4.6-1-5 are used.

Table 4.6-1-5 UTRA carrier RSSI Inter frequency relative accuracy

Parameter	Unit	Accuracy	
		Normal condition	Extreme condition
<i>I_o</i>	dBm	± 5	± 8

4.6.1.1.3.4 Range/mapping

UTRA carrier RSSI is given with a resolution of 1 dB with the range [-94, ..., -32] dBm.		
UTRA carrier RSSI shall be reported in the unit UTRA_carrier_RSSI_LEV where:		
UTRA_carrier_RSSI_LEV_00:		UTRA_carrier_RSSI < -94dBm
UTRA_carrier_RSSI_LEV_01:	-94dBm ≤	UTRA_carrier_RSSI < -93dBm
UTRA_carrier_RSSI_LEV_02:	-93dBm ≤	UTRA_carrier_RSSI < -92dBm
...		
UTRA_carrier_RSSI_LEV_61:	-34dBm ≤	UTRA_carrier_RSSI < -33dBm
UTRA_carrier_RSSI_LEV_62:	-33dBm ≤	UTRA_carrier_RSSI < -32dBm
UTRA_carrier_RSSI_LEV_63:	-32dBm ≤	UTRA_carrier_RSSI

4.6.1.1.7 SFN-SFN observed time difference

4.6.1.1.7.1 Accuracy requirements

Table 4.6-1-6 SFN-SFN observed time difference accuracy

Parameter	Unit	Accuracy
<i>SFN-SFN observed time difference</i>	chips period	+/-0.5 for both type 1 and 2

4.6.1.1.7.2 Range/mapping

<p>Type 1: SFN-SFN observed time difference is given with a resolution of 1 chip with the range [0; 3276800] chips (22 bits). SFN-SFN observed time difference shall be reported in the unit T1_SFN-SFN_TIME, where T1_SFN-SFN_TIME_N: $N * 1 \text{ chip} \leq \text{SFN-SFN observed time difference} < (N+1) * 1 \text{ chip}$ With N= 0, 1, 2, ..., 3276799</p> <p>Type 2: SFN-SFN observed time difference is given with a resolution of 0.25 chip with the range (-6400; 6400] chips (16 bits). SFN-SFN observed time difference shall be reported in the unit T2_SFN-SFN_TIME, where T2_SFN-SFN_TIME_N: $N * 0.25 \text{ chip} - 6400 \text{ chips} < \text{SFN-SFN observed time difference} \leq (N+1) * 0.25 \text{ chip} - 6400 \text{ chips}$ With N= 0, 1, 2, ..., 51199</p>

[Explanation difference:]

In 1.28Mcps TDD there are 12800chips per frame while in 3.84Mcps TDD there are 38400chips. According to this chip number difference, the observed time difference range in type 1 should be changed correspondingly.

There are 3 kind of special time slot (DwPTS, UpPTS and GP) in 1.28Mcps TDD frame structure (see section 7.2.1 'frame structure' in TR 25.928). When calculation the SFN-SFN observed time difference in type 2, it needs to consider the position and affection of these 3 special time slots.

Let us suppose:

T_{RXTSi} : time of start of timeslot#0 received of the serving TDD cell i.

T_{RXTSk} : time of start of timeslot#0 received from the target UTRA cell k that is closest in time to the start of the timeslot of the serving TDD cell i.

SFN-SFN observed time difference = $T_{RXTSk} - T_{RXTSi}$, in chips, which means to calculate the the time difference of the start position of the current frame in cell i to the closest starting position of one frame in cell k.

[Editor Note:]

Here in type 2 we only consider to measure the difference of two cells of 1.28Mcps TDD. The measurement method is like that in TS25.215. In type 2 measurement of TS25.215, it measures the time difference of the start position of the P-CPICH of two cells. That is just something like in 1.28Mcps TDD.

4.6.2 Measurements Performance for UTRAN in 1.28Mcps TDD

option

4.6.2.1 Performance for UTRAN Measurements in Uplink (RX)

If not otherwise stated, the test parameters in table 4.6-2-1 should be applied for UE RX measurements requirements in this section.

Table 4.6-2-1 Intra frequency test parameters for UTRAN RX Measurements

Parameter	Unit	Cell 1
<i>UTRA RF Channel number</i>		Channel 1
<i>Timeslot</i>		[]
<i>DPCH Ec/Ior</i>	dB	[]
\hat{I}_{or}/I_{oc}	dB	[]
<i>I_{oc}</i>	dBm/ 1.28 MHz	-91
<i>Range: I_o</i>	dBm	-106..-75
<i>Propagation condition</i>	-	AWGN

4.6.2.1.8 RX Timing Deviation

4.6.2.1.8.1 Accuracy requirements

Parameter	Unit	Accuracy
<i>RX Timing Deviation</i>	-chips period	+/- 0.125

4.6.2.1.8.2 Range/mapping

RX Timing Deviation is given with a resolution of $[1/8]$ chip with the range $[-128;128)$ chip (11 bit) in random access procedure.
 RX Timing Deviation is given with a resolution of $[1/8]$ chip with the range $[-1/8; 1/8]$ chip (2 bit) in DPCH.
 RX Timing Deviation cell shall be reported in the unit RX_TIME_DEV, where
 RX_TIME_DEV: $(N * 1/8 - 128) \text{ chips} \leq \text{RX Timing Deviation} < ((N+1) * 1/8 - 128) \text{ chips}$
 With $N = 0, 1, 2, \dots, 2047$

NOTE: This measurement can be used for timing advance (synchronisation shift) calculation for uplink synchronisation or location services.

[Explanation difference:]

In 3.84Mcps TDD the ‘RX Timing Deviation’ measurement is only needed to report to the higher layer for timing advance calculation or location services. It does not need to measure this value continuously.

While in 1.28Mcps TDD this measurement is not only reported to higher layer, but also severed as a physical signal (‘Synchronisation Shift’ or ‘SS’) to keep uplink synchronisation. It needs to be refreshed every 5ms (every sub-frame). The resolution requirement is $1/8$ chip as described in section 10.2 ‘Timing Advance’ of TR25.928.

Because SS is severed as a physical layer signal in 1.28Mcps TDD, it needs to consider how to map this value onto data burst. When in random access procedure the SS control step should have a large range to quickly establish the uplink synchronisation. While in normal working procedure to maintain the uplink synchronisation it should use as little bits as possible to reduce the affection to the DPCH capacity. These consideration are described in section 10.2 ‘Timing Advance’ and section 8.2.2 ‘Coding of Synchronisation Shift’ of TR25.928.

Annex 4.A RF Power Management Scenario

Annex 4.B RF Handover Scenario

5 UE Radio Transmission and Reception

5.1 Frequency bands and channel arrangement

5.1.1 General

The information presented in this section is based on a chip rate of 1,28Mcps.

5.1.2 Frequency bands

Common with 3,84Mcps TDD option.

5.1.3 TX–RX frequency separation

[Description:]

No TX-RX frequency separation is required as Time Division Duplex (TDD) is employed. Each subframe of 1.28Mcps TDD consists of 7 main timeslots where all main timeslots (at least the first one) before the single switching point are allocated DL and all main timeslots (at least the last one) after the single switching point are allocated UL.

[Explanation of difference:]

The frame structure for 3.84Mcps TDD and 1.28Mcps TDD is different. For 3.84 Mcps TDD, each TDMA frame consists of 15 timeslots where each timeslot can be allocated to either transmit or receive.

5.1.4 Channel arrangement

5.1.4.1 Channel spacing

5.1.4.1.1 Background

The roll filter factor is would be 0.22, then we select the nominal bandwidth as 1.6MHz;
Considering the easy co-existence with Wide-band TDD mode, for its 3 times bandwidth would be 4.8, less than the nominal bandwidth of wide band UTRA TDD;
It is just nominal for 1.6MHz, and it is also flexible to adjust the channel raster step 200kHz to narrow as 1.4MHz for strict requirement situations if needed;

Considering the easy to implementation, for too narrow band of the bandwidth would be very difficult to implementation.

5.1.4.1.2 Channel spacing

The channel spacing for 1.28Mcps chip rate option is 1.6MHz.

5.1.4.2 Channel raster

Common with 3,84Mcps TDD option.

5.1.4.3 Channel number

Common with 3,84Mcps TDD option.

5.2 Transmitter characteristics

5.2.1 General

Common with 3,84Mcps TDD option.

5.2.2 Transmit power

5.2.2.1 User Equipment maximum output power

Common with 3,84Mcps TDD option.

5.2.3 UE frequency stability

Common with 3,84Mcps TDD option.

5.2.4 Output power dynamics

Power control is used to limit the interference level.

5.2.4.1 Open loop power control

Open loop power control is the ability of the UE transmitter to sets its output power to a specific value. The open loop power control tolerance is given in Table 5.2.3

5.2.4.1.1 minimum requirement

The UE open loop power is defined as the average power in a timeslot or ON power duration, whichever is available, and they are measured with a filter that has a Root-Raised Cosine (RRC) filter response with a roll off $\alpha = 0.22$ and a bandwidth equal to the chip rate.

Table 5.2.3: Open loop power control

Normal conditions	± 9 dB
Extreme conditions	± 12 dB

5.2.4.2 Closed loop power control in the uplink

Closed loop power control in the Uplink is the ability of the UE transmitter to adjust its output power in accordance with one or more TPC commands received in the downlink.

5.2.4.2.1 Power control steps

The power control step is the change in the UE transmitter output power in response to a single TPC command, TPC_cmd, arrived at the UE.

5.2.4.2.1.1 Minimum requirement

The UE transmitter shall have the capability of changing the output power with a step size of 1, 2 and 3 dB according to the value of Δ_{TPC} or $\Delta_{\text{RP-TPC}}$, in the slot immediately after the TPC_cmd can be arrived.

- (a) The transmitter output power step due to closed loop power control shall be within the range shown in Table 5.2.4.
- (b) The transmitter average output power step due to closed loop power control shall be within the range shown in Table 5.2.5. Here a TPC_cmd group is a set of TPC_cmd values derived from a corresponding sequence of TPC commands of the same duration.

The closed loop power is defined as the relative power differences between averaged power of original (reference) timeslot and averaged power of the target timeslot without transient duration. They are measured with a filter that has a Root-Raised Cosine (RRC) filter response with a roll off $\alpha = 0.22$ and a bandwidth equal to the chip rate.

Table 5.2.4: Transmitter power control range

TPC_cmd	Transmitter power control range					
	1 dB step size		2 dB step size		3 dB step size	
	Lower	Upper	Lower	Upper	Lower	Upper
Up	+0.5 dB	+1.5 dB	+1 dB	+3 dB	+1.5 dB	+4.5 dB
Down	-0.5 dB	-1.5 dB	-1 dB	-3 dB	-1.5 dB	-4.5 dB

Table 5.2.5: Transmitter average power control range

TPC_ cmd group	Transmitter power control range after 10 equal TPC_ cmd groups					
	1 dB step size		2 dB step size		3 dB step size	
	Lower	Upper	Lower	Upper	Lower	Upper
Up	+8 dB	+12 dB	+16 dB	+24 dB	+24 dB	+36 dB
Down	-8 dB	-12 dB	-16 dB	-24 dB	-24 dB	-36 dB

5.2.4.3 Minimum transmit output power

The minimum controlled output power of the UE is when the power control setting is set to a minimum value. This is when both the closed loop and open loop power control indicate a minimum transmit output power is required.

5.2.4.3.1 Minimum requirement

The minimum transmit power is defined as an averaged power in a time slot measured with a filter that has a Root-Raised Cosine (RRC) filter response with a roll off $\alpha = 0.22$ and a bandwidth equal to the chip rate. The minimum transmit power shall be better than -49 dBm/1.28MHz.

[Rationale:]

For the power control issue, the open loop and closed loop power control procedure is introduced in 1.28Mcps TDD option [4], basically has the similar requirements as that of UTRA FDD.

The minimum transmit output power is basically kept in line with 3.84Mcps TDD mode, just considering the RRC measurement filter bandwidth is 1/3 of 3.84Mcps TDD mode, so the figure is scaleable change accordingly.

5.2.5 Transmit ON/OFF power

5.2.5.1 Transmit OFF power

The transmit OFF power state is when the UE does not transmit. This parameter is defined as the maximum output transmit power within the channel bandwidth when the transmitter is OFF.

5.2.5.1.1 Minimum Requirement

The requirement for transmit OFF power shall be better than -65 dBm measured with a filter that has a Root-Raised Cosine (RRC) filter response with a roll off $\alpha=0.22$ and a bandwidth equal to the chip rate.

[Rational]:

In TDD mode, various users are transmitting and receiving on the same frequency band. A maximum transmit output power in the transmitter idle mode has to be defined not to affect other nearby receiving

mobiles or BSs. Then received power due to a near by UE has to be required below the noise floor.

The maximum acceptable transmit off power level can be represented as follows

$$\text{Transmit off power level [dBm]} < -174 [\text{dBm/Hz}] + 10\log(1.28\text{M[Hz]}) + \text{NF} + \text{MCL},$$

Assuming a minimum coupling loss (MCL) of 40 dB between mobiles and a noise figure (NF) of 9 dB for the UE, then we can get:

$$\text{Transmit off power level [dBm]} < -113 + 9 + 40 = -64\text{dBm},$$

I.e., the transmit off power level has to be below -64 dBm.

A selected value of -65 dBm leads to minor degradation in the receiver sensitivity, and also leads to well compatible with 3.84Mcps TDD option.

5.2.5.2 Transmit ON/OFF Time mask

5.2.6 Output RF spectrum emissions

5.2.6.1 Occupied bandwidth

[Description:]

Occupied bandwidth is a measure of the bandwidth containing 99% of the total integrated power for transmitted spectrum and is centered on the assigned channel frequency. The occupied channel bandwidth is about 1.6 MHz based on a chip rate of 1.28 Mcps.

[Explanation of difference:]

In 3.84Mcps TDD, the occupied channel bandwidth is less than 5MHz based on 3.84Mcps.

But in 1.28Mcps TDD, as the background analysis in WG4#12 Meeting Tdoc515, which has been accepted to into the TR25.945, the occupied channel bandwidth should be less than 1.6 MHz based on 1.28 Mcps.

5.2.6.2 Out of band emission

5.2.6.2.1 Spectrum emission mask

For the 1.28Mcps chip rate option, UE emission shall not exceed the levels specified in the following table.

Table 5.2.6.2.1-1: UE Spectrum Emission Mask Requirement(1.28Mcps chip rate)

Frequency offset from carrier Δf	Minimum requirement	Measurement bandwidth
0.8 – 1.12 MHz	$-35] - [31] * (\Delta f - [0.8])$ dBc	30 kHz *
1.12 - 2.4 MHz	$[-35] - [2.5] * (\Delta f - [1.12])$	[0.3] MHz *

	dBc	
2.4 – 2.72 MHz	$[-39] - [31]*(\Delta f - [2.4])\text{dBc}$	[0.3] MHz *
2.72 – 4.0 MHz	[-49] dBc	[0.3] MHz *

Note

The first and last measurement position with a 30 kHz filter is 0.815 MHz and 1.105 MHz

The first and last measurement position with a [0.3] MHz filter is 1.27 MHz and 4 MHz

5.2.6.2.2 Adjacent Channel Leakage power Ratio (ACLR)

For the 1.28Mcps chip rate option, the ACLR shall be better than the value specified in the following Table.

Table 5.2.6.2.2-1 : UE ACLR (1.28Mcps chip rate)

Power Class	UE channel	ACLR limit
21dBm	± 1.6 MHz	[33] dB
21dBm	± 3.2 MHz	[43] dB

5.2.6.3 Spurious emissions

Spurious emissions are emissions which are caused by unwanted transmitter effects such as harmonics emission, parasitic emission, intermodulation products and frequency conversion products, but exclude out of band emissions.

The frequency boundary and the detailed transitions of the limits between the requirement for out band emissions and spectrum emissions are based on ITU-R Recommendations SM.329.

5.2.6.3.1 Minimum Requirement

These requirements are only applicable for frequencies which are greater than 4 MHz away from the UE center carrier frequency.

Table 5.2.6.3-1a : General Spurious emissions requirements

Frequency Bandwidth	Resolution Bandwidth	Minimum requirement
$9 \text{ kHz} \leq f < 150 \text{ kHz}$	1 kHz	-36 dBm
$150 \text{ kHz} \leq f < 30 \text{ MHz}$	10 kHz	-36 dBm
$30 \text{ MHz} \leq f < 1000 \text{ MHz}$	100 kHz	-36 dBm
$1 \text{ GHz} \leq f < 12.75 \text{ GHz}$	1 MHz	-30 dBm

Table 5.2.6.3-1b : Additional Spurious emissions requirements

Frequency Bandwidth	Resolution Bandwidth	Minimum requirement
$925 \text{ MHz} \leq f \leq 935 \text{ MHz}$	100 KHz	-67 dBm*
$935 \text{ MHz} < f \leq 960 \text{ MHz}$	100 KHz	-79 dBm*
$1805 \text{ MHz} \leq f \leq 1880 \text{ MHz}$	100 KHz	-71 dBm*

Note

* The measurements are made on frequencies which are integer multiples of 200 kHz. As exceptions, up to five measurements with a level up to the applicable requirements defined in Table 5.2.7a are permitted for each UARFCN used in the measurement.

[Explanation of difference:]

The UE TX Spurious emissions requirements basically keep in line with UTRAN FDD and 3.84Mcps TDD.

For the frequency offset, as ITU specification SM.329, the frequency limit between out of band emissions and spurious emissions is defined as 250% of the necessary bandwidth. In 1.28Mcps option the necessary bandwidth is 1.6MHz, so the frequency offset from carrier frequency is

$$250 \% \times 1.6 MHz = 4 MHz$$

5.2.7 Transmit intermodulation

5.2.7.1 Minimum requirements

For the 1.28Mcps chip rate option, the requirement of transmitting intermodulation for carrier spacing 1.6MHz is prescribed in the following table.

Table 5.2.7-1 . Transmitting intermodulation attenuation.

Interference signal frequency offset	1.6MHz	3.2MHz
Interference signal level	[-40]dBc	
Minimum requirement of intermodulation products	[-31] dBc	[-41] dBc

Note: This requirement is applicable to the 21 dBm power class of UE.

5.2.8 Transmit Modulation

5.2.8.1 Transmit pulse shape filter

The transmit pulse-shaping filter is a root-raised cosine (RRC) with roll-off $\alpha = 0.22$ in the frequency domain. The impulse response of the chip impulse filter $RC_0(t)$ is

$$RC_0(t) = \frac{\sin\left(\pi \frac{t}{T_C}(1-\alpha)\right) + 4\alpha \frac{t}{T_C} \cos\left(\pi \frac{t}{T_C}(1+\alpha)\right)}{\pi \frac{t}{T_C} \left(1 - \left(4\alpha \frac{t}{T_C}\right)^2\right)}$$

Where the roll-off factor $\alpha = 0.22$ and the chip duration: $T_C = \frac{1}{\text{chiprate}} = 0.78125 \mu s$

5.2.8.2 Modulation Accuracy

Common with 3.84Mcps TDD option.

5.2.8.2.1 Minimum Requirement

Common with 3.84Mcps TDD option.

5.2.8.3 Peak Code Domain Error

Common with 3.84Mcps TDD option.

5.2.8.3.1 Minimum Requirement

Common with 3.84Mcps TDD option.

[Rational:]

For 3.84Mcps and FDD, the minimum requirements for the error vector magnitude and peak code domain error ensures that

the error vector magnitude does not degrade the performance

the error vector magnitude leads only to low increase for the transmitted output power to remain the E_b/N_0

The theoretical investigations have shown that the error vector magnitude is related to the spreading factor. Because the same spreading factors are used for low chip rate TDD and for high chiprate TDD, the same minimum requirement applies.

5.3 Receiver characteristics

5.3.1 General

Common with 3,84Mcps TDD option.

5.3.2 Diversity characteristics

Common with 3,84Mcps TDD option.

5.3.3 Reference sensitivity level

The reference sensitivity is the minimum receiver input power measured at the antenna port at which the BIT Error Ratio BER does not exceed a specific value.

5.3.3.1 Minimum Requirements

The BER shall not exceed 0.001 for the parameters specified in Table 5.3.2.

Table 5.3.3-1 : Test parameters for reference sensitivity

Parameter	Level	Unit
$\frac{\Sigma\text{DPCH_Ec}}{I_{\text{or}}}$	0	dB
\hat{I}_{or}	-108	dBm/1.28 MHz

[Simulation results:]

The simulation is done to 12.2kb/s data in static propagation condition for UE of 1.28Mcps TDD. The service-mapping is specified in ANNEX: *Measurement Channel*, and the simulation assumption is specified in “*Simulation Assumption for 1.28Mcps Chip Rate TDD option*”.

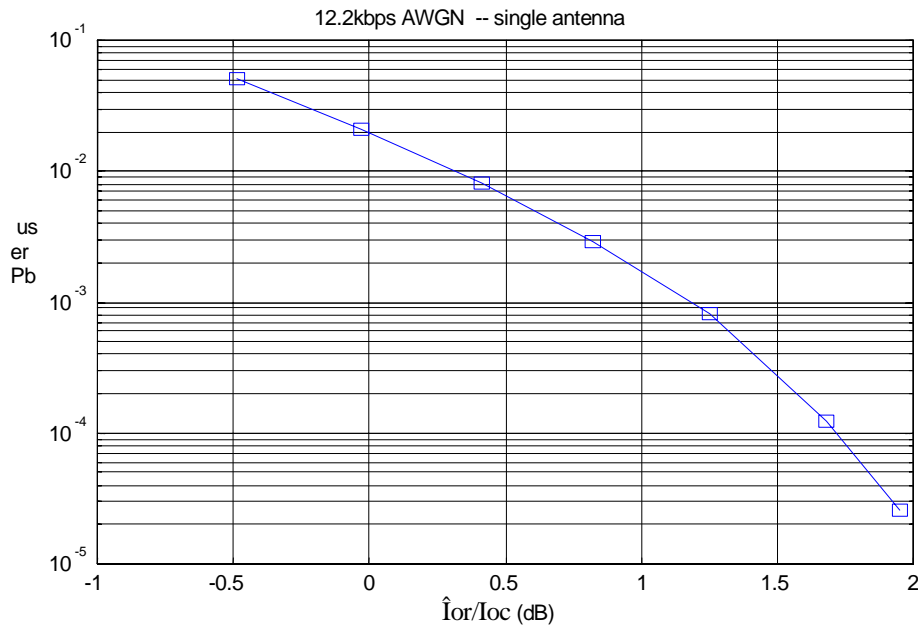

$\hat{I}_{\text{or}}/I_{\text{oc}}$	Pb
-0.49	5.09E-2
-0.03	2.12E-2
0.41	8.11E-3
0.82	2.90E-3
1.25	8.12E-4
1.68	1.23E-4
1.95	2.61E-5

5.3.4 Maximum input level

This is defined as the maximum receiver input power at the UE antenna port which does not degrade the specified BER performance.

5.3.4.1 Minimum Requirements

The BER shall not exceed 0.001 for the parameters specified in Table 5.3.3

Table 5.3.4-1: Maximum input level

Parameter	Level	Unit
$\frac{\Sigma DPCH_Ec}{I_{or}}$	-7	dB
\hat{I}_{or}	-25	dBm/1.28 MHz

5.3.5 Adjacent Channel Selectivity (ACS)

Adjacent Channel Selectivity is a measure of a receiver's ability to receive a wanted signal at its assigned channel frequency in the presence of adjacent channel signal at a given frequency offset from the centre frequency of the assigned channel. ACS is the ratio of the receive filter attenuation on the assigned channel frequency to the receiver filter attenuation on the adjacent channel(s).

5.3.5.1 Minimum Requirement

The ACS shall be better than the value indicated in Table 5.3.4 for the test parameters specified in Table 5.3.5 where the BER shall not exceed 0.001

Table 5.3.5-1: Adjacent Channel Selectivity

Power Class	Unit	ACS
2	dB	33
3	dB	33

Table 5.3.5-2: Test parameters for Adjacent Channel Selectivity

Parameter	Unit	Level
$\frac{\Sigma DPCH_Ec}{I_{or}}$	dB	0
\hat{I}_{or}	dBm/1.28MHz	-91
I_{oac}	dBm/1.28 MHz	-54

F_{uw} offset	MHz	+1.6 or -1.6
-----------------	-----	--------------

[Rationale:]

The ACS performance of terminals is largely determined by an IF filter (usually a SAW), the A/D converter and digital baseband filtering. And the ACS requirements should reflect what can be achieved with present state of the art technology. So we can select the same receiver filter performance as 3.84Mcps TDD, ACS equals to 33 dBc.

The reference sensitivity value of UE for 1.28Mcps TDD is derived from the following formula. Assuming the noise figure (NF) of UE is 9dB, the noise floor is:

$$P_N = -174 \text{ dBm/Hz} + 10\log(1.28 \text{ MHz/Hz}) + \text{NF}(9 \text{ dB}) = -104 \text{ dBm}$$

And the reference sensitivity value of -108dBm is proposed to the UE specification for 1.28Mcps TDD in [1].

The wanted signal is set at -91dBm, just like that of 3.84Mcps TDD, i.e., the wanted signal is 17dB above sensitivity level.

$$-91 - (-108) = 17\text{dB}$$

So the adjacent signal is allowed to be 17dB above of the noise floor. Then the unwanted adjacent level could be derived as below:

$$\begin{aligned} P_i &\leq \text{noise floor [dBm]} + 17\text{dB (because the wanted signal is 17 dB above sensitivity)} + \text{ACS} \\ &= -104 \text{ dBm} + 17 \text{ dB} + 33 \text{ dBc} \\ &= -54 \text{ dBm} \end{aligned}$$

5.3.6 Blocking characteristics

The blocking characteristics is a measure of the receiver ability to receive a wanted signal at its assigned channel frequency in the presence of an unwanted interferer on frequencies other than those of the spurious response or the adjacent channels without this unwanted input signal causing a degradation of the performance of the receiver beyond a specified limit. The blocking performance shall apply at all frequencies except those at which a spurious response occur.

5.3.6.1 Minimum Requirement

The BER shall not exceed 0.001 for the parameters specified in table 5.3.6-1 and table 5.3.6-2. For table 13 up to 24 exceptions are allowed for spurious response frequencies in each assigned frequency channel when measured using a 1MHz step size.

Table 5.3.6-1: In-band blocking

Parameter	Offset	Offset	Unit
Wanted Signal Level	<REFSENS> + 3 dB	<REFSENS> + 3 dB	dBm/1.28 MHz
Unwanted Signal Level (modulated)	-61	-49	dBm/1.28 MHz
F _{uw} (offset)	+3.2 or -3.2	+4.8 or -4.8	MHz

Table 5.3.6-2: Out of band blocking

Parameter	Band 1	Band 2	Band 3	Unit
Wanted Signal Level	<REFSENS> + 3 dB	<REFSENS> + 3 dB	<REFSENS> + 3 dB	dBm/1.28 MHz
Unwanted Signal Level (CW)	-44	-30	-15	dBm
F _{uw} For operation in frequency bands as defined in subclause 5.2(a)	1840 <f <1895.2 1924.8 <f <2005.2 2029.8 <f <2085	1815 <f <1840 2085 <f <2110	1 <f <1815 2110 <f <12750	MHz
F _{uw} For operation in frequency bands as defined in subclause 5.2(b)	1790 <f < 1845.2 1994.8 <f < 2050	1765 <f < 1790 2050 <f < 2075	1 <f < 1765 2075 <f < 12750	MHz
F _{uw} For operation in frequency bands as defined in subclause 5.2(c)	1850 <f < 1905.2 1934.8 <f < 1990	1825 <f < 1850 1990 <f < 2015	1 <f < 1825 2015 <f < 12750	MHz

Note: 1. For operation referenced in 5.1.2(a), from 1895.2 <f < 1900 MHz, 1920 <f < 1924.8 MHz, 2005.2 <f < 2010 MHz and 2025 <f < 2029.8 MHz, the appropriate in-band blocking or adjacent channel selectivity in section 5.3.5.1 shall be applied.

For operation referenced in 5.1.2(b), from 1845.2 <f < 1850 MHz and 1990 <f < 1994.8 MHz, the appropriate in-band blocking or adjacent channel selectivity in section 5.3.5.1 shall be applied.

For operation referenced in 5.1.2(c), from 1905.2 <f < 1910 MHz and 1930 <f < 1934.8 MHz, the appropriate in-band blocking or adjacent channel selectivity in section 5.3.5.1 shall be applied.

[Rationale]:

3.2MHz blocking requirement

From [1,2] the required interfering signal level can be calculated, just like FDD,

$$I_{\text{blocking}} = NF + 10 \cdot \log(1.28\text{Mcps}) - 174\text{dBm/Hz} + ACS2,$$

$$I_{\text{blocking}} = 9\text{ dB} + 61\text{ dB} - 174\text{dBm/Hz} + 43\text{ dB} = -61\text{ dBm}.$$

ACS Adjacent channel selectivity

NF Noise figure

In the equations above, the ACS2 is assumed as 43dB, and NF is assumed as 9dB. The principle is basically like FDD and 3.84Mcps TDD, just the chiprate has been changed, so the in band blocking value is also scalable changed.

Considering the chiprate is 1.28Mcps, so the unwanted signal frequency offset is also scalable changed from 3.84Mcps TDD.

Out of band blocking requirement

The relevant frequency bands for out of band blocking are calculated according to the specified frequency bands for FDD in[3] and 3.84Mcps TDD in [4].

Note: Reference

- 1.Nokia, Ericsson,FDD UE Blocking Requirement, TSGR4#6(99) 393
- 2.Siemens, Blocking characteristics, Spurious response, Intermodulation characteristics for UE TDD, TSGR4#7(99) 457
3. Nokia, Ericsson, Revised FDD UE Blocking Requirement, TSGR4#6(99) 431
4. TS 25.102 V3.30

5.3.7 Spurious response

5.3.7.1 Minimum Requirements

For the 1.28Mcps chip rate option, the requirement of Spurious response for carrier spacing 1.6MHz is prescribed in the following table.

Table 5.3.7.1: Spurious Response (1.28MHz chiprate)

Parameter	Level	Unit
Wanted Signal Level	<REFSENS> + 3 dB	dBm/1.28 MHz
Unwanted Signal Level (CW)	[-44]	dBm
F _{uw}	Spurious response frequencies	MHz

5.3.8 Intermodulation characteristics

5.3.8.1 Minimum Requirements

For the 1.28Mcps chip rate option, the requirement of intermodulation for carrier spacing 1.6MHz is prescribed in the following table.

Table 5.3.8-1: Receive intermodulation characteristics (1.28MHz chiprate)

Parameter	Level	Unit
$\frac{\Sigma DPCCH - Ec}{I_{or}}$	0	dB
\hat{I}_{or}	<REFSENS> + 3 dB	dBm/1.28 MHz
I_{ouw1} (CW)	[-46]	dBm
I_{ouw2} (modulated)	[-46]	dBm/1.28 MHz
F_{uw1} (CW)	3.2	MHz
F_{uw2} (Modulated)	6.4	MHz

5.3.9 Spurious emissions

The Spurious Emissions Power is the power of emissions generated or amplified in a receiver that appear at the UE antenna connector.

5.3.9.1 Minimum Requirement

The power of any spurious emission shall not exceed:

Table 5.3.9-1: Receiver spurious emission requirements

Band	Maximum level	Measurement Bandwidth	Note
9 kHz – 1 GHz	-57 dBm	100 kHz	
1 GHz – 1.9 GHz and 1.92 GHz – 2.01 GHz and 2.025 GHz – 2.11 GHz	-47 dBm	1 MHz	With the exception of frequencies between 4MHz below the first carrier frequency and 4MHz above the last carrier frequency used by the UE.
1.9 GHz – 1.92 GHz and 2.01 GHz – 2.025 GHz and 2.11 GHz – 2.170 GHz	-64 dBm	1.28 MHz	With the exception of frequencies between 4MHz below the first carrier frequency and 4MHz above the last carrier frequency used by the UE.
2.170 GHz – 12.75 GHz	-47 dBm	1 MHz	

[Rationale]:

The inband (Band 3 in the above table) RX spurious emission value could be conducted as below.

Assumptions:

The Noise Figure (NF) of the UE receiver is 9dB;

The MCL for UE's is 40dB.

So the derivation is as follows:

Spurious level – MCL (Minimum Coupling Loss) < Thermal noise

Spurious level < Thermal noise + MCL = $kT_0 + NF + MCL = -174\text{dBm/Hz} + 9\text{dB} + 40\text{dB} = -125\text{dBm/Hz}$

In other way, in 1.28Mcps TDD,

Spurious level < -64dBm/ 1.28MHz (= -125dBm/Hz)

The spurious levels in Band 1,2 and 4 are independent if the disturber is a FDD UE or aTDD UE. Therefore we propose to adopt these values for 1.28Mcps TDD UE, just like 3.84Mcps TDD UE.

The values of the 1.28Mcps TDD UE receiver spurious levels from point 1 to 4 are proposed for approval for 1.28Mcps TDD taking into account the impact of the TDD UE receiver spurious emission to the FDD UE receiver band.

For the frequency offset, as ITU specification, the frequency limit between out of band emissions and spurious emissions is defined as 250% of the necessary bandwidth. In 1.28Mcps option the necessary bandwidth is 1.6MHz, so the frequency offset from carrier frequency is

$$250 \% \times 1.6 \text{ MHz} = 4 \text{ MHz} .$$

5.4 Performance requirement

5.4.1 General

The performance requirements for the UE in this section are specified for the measurement channels specified in Annex 5.A and the propagation condition specified in Annex 5.B.

Table 5.4.1: Summary of UE performance targets

Test Chs.	Information Data Rate	Static	Multi-path Case 1	Multi-path Case 2	Multi-path Case 3
		Performance metric			
DCH	12.2 kbps	$\text{BLER} < 10^{-2}$	$\text{BLER} < 10^{-2}$	$\text{BLER} < 10^{-2}$	$\text{BLER} < 10^{-2}$
	64 kbps	$\text{BLER} < 10^{-1}, 10^{-2}$	$\text{BLER} < 10^{-1}, 10^{-2}$	$\text{BLER} < 10^{-1}, 10^{-2}$	$\text{BLER} < 10^{-1}, 10^{-2}, 10^{-3}$
	144 kbps	$\text{BLER} < 10^{-1}, 10^{-2}$	$\text{BLER} < 10^{-1}, 10^{-2}$	$\text{BLER} < 10^{-1}, 10^{-2}$	$\text{BLER} < 10^{-1}, 10^{-2}, 10^{-3}$
	384 kbps	$\text{BLER} < 10^{-1}, 10^{-2}$	$\text{BLER} < 10^{-1}, 10^{-2}$	$\text{BLER} < 10^{-1}, 10^{-2}$	$\text{BLER} < 10^{-1}, 10^{-2}, 10^{-3}$

5.4.2 Demodulation in static propagation conditions

5.4.2.1 Demodulation of DCH

The performance requirement of DCH in static propagation conditions is determined by the maximum Block Error Ratio (BLER). The BLER is specified for each individual data rate of the DCH. DCH is mapped into the Dedicated Physical Channel (DPCH).

5.4.2.1.1 Minimum requirement

For the parameters specified in Table 5.4.2 the BLER should not exceed the piece-wise linear BLER curve specified in Table 5.4.3.

Table 5.4.2: DCH parameters in static propagation conditions

Parameters	Unit	Test 1	Test 2	Test 3	Test 4
Number of DPCH _o		8	2	2	0
$\frac{DPCH_o - E_c}{I_{or}}$	dB	-10	-10	-10	0
I _{oc}	DBm/1.28MHz	-60			
Information Data Rate	Kbps	12.2	64	144	384

Table 5.4.3: Performance requirements in AWGN channel.

Test Number	$\frac{\hat{I}_{or}}{I_{oc}}$ [dB]	BLER
1		10^{-2}
2		10^{-1}
		10^{-2}
3		10^{-1}
		10^{-2}
4		10^{-1}

		10^{-2}
--	--	-----------

5.4.3 Demodulation of DCH in multipath fading conditions

5.4.3.1 Multipath fading Case 1

The performance requirement of DCH is determined by the maximum Block Error Ratio (BLER). The BLER is specified for each individual data rate of the DCH. DCH is mapped into the Dedicated Physical Channel (DPCH).

5.4.3.1.1 Minimum requirement

For the parameters specified in Table 5.4.4 the BLER should not exceed the piece-wise linear BLER curve specified in Table 5.4.5.

Table 5.4.4: DCH parameters in multipath Case 1 channel

Parameters	Unit	Test 1	Test 2	Test 3	Test 4
Number of DPCH _o		8	2	2	0
$\frac{DPCH_o - E_c}{I_{or}}$	DB	-10	-10	-10	0
I _{oc}	dBm/1.28MHz	-60			
Information Data Rate	Kbps	12.2	64	144	384

Table 5.4.5: Performance requirements in multipath Case 1 channel.

Test Number	$\frac{\hat{I}_{or}}{I_{oc}}$ [dB]	BLER
1		10^{-2}
2		10^{-1}
		10^{-2}
3		10^{-1}
		10^{-2}
4		10^{-1}
		10^{-2}

5.4.3.2 Multipath fading Case 2

The performance requirement of DCH is determined by the maximum Block Error Ratio (BLER). The BLER is specified for each individual data rate of the DCH. DCH is mapped into the Dedicated Physical Channel (DPCH).

5.4.3.2.1 Minimum requirement

For the parameters specified in Table 5.4.6 the BLER should not exceed the piece-wise linear BLER curve specified in Table 5.4.7.

Table 5.4.6: DCH parameters in multipath Case 2 channel

Parameters	Unit	Test 1	Test 2	Test 3	Test 4
Number of DPCH _o		8	2	2	0
$\frac{DPCH_o - E_c}{I_{or}}$	dB	-10	-10	-10	0
I _{oc}	dBm/1.28MHz	-60			
Information Data Rate	Kbps	12.2	64	144	384

Table 5.4.7: Performance requirements in multipath Case 2 channel.

Test Number	$\frac{\hat{I}_{or}}{I_{oc}}$ [dB]	BLER
1		10 ⁻²
2		10 ⁻¹
		10 ⁻²
3		10 ⁻¹
		10 ⁻²
4		10 ⁻¹
		10 ⁻²

5.4.3.3 Multipath fading Case 3

The performance requirement of DCH is determined by the maximum Block Error Ratio (BLER). The BLER is specified for each individual data rate of the DCH. DCH is mapped into the Dedicated Physical Channel (DPCH).

5.4..3.3.1 Minimum requirement

For the parameters specified in Table 5.4.8 the BLER should not exceed the piece-wise linear BLER curve specified in Table 5.4.9.

Table 5.4.8: DCH parameters in multipath Case 3 channel

Parameters	Unit	Test 1	Test 2	Test 3	Test 4
Number of DPCH _o		8	2	2	0
$\frac{DPCH_o - E_c}{I_{or}}$	dB	-10	-10	-10	0
I _{oc}	dBm/1.28MHz	-60			
Information Data Rate	Kbps	12.2	64	144	384

Table 5.4.9: Performance requirements in multipath Case 3 channel.

Test Number	$\frac{\hat{I}_{or}}{I_{oc}}$ [dB]	BLER
12.2 kbps		10 ⁻²
64 kbps		10 ⁻¹

		10^{-2}
		10^{-3}
144 kbps		10^{-1}
		10^{-2}
		10^{-3}
384 kbps		10^{-1}
		10^{-2}
		10^{-3}

[Explanation difference:]

The different performance requirement is result from different propagation condition (Annex 5.B), different service mapping (Annex 5.A) ,different simulation assumption and different chip rate with 3.84Mcps chip rate TDD.

The BCH test case, is testing the block STTD capability of the terminal. Block STTD is currently not supported by 1.28Mcps chip rate TDD, as specified in TR 25.928. Therefore this test case is not needed for 1.28Mcps chip rate TDD.

Annex 5.A (normative): Measurement Channels

5.A.1 General

5.A.2 Reference Measurement Channels

5.A.2.1 DL reference measurement channel (12.2 kbps)

Parameter	
Information data rate	12.2 kbps
RU's allocated	1TS (2*SF16) = 2RU/5ms
Midamble	144
Interleaving	20 ms
Power control (TPC)	4 Bit/user/10ms
TFCI	16 Bit/user/10ms
Synchronisation Shift (SS)	4 Bit/user/10ms
Inband signalling DCCH	2 kbps

Puncturing level at Code rate 1/3: DCH / DCCH	33% / 33%
---	-----------

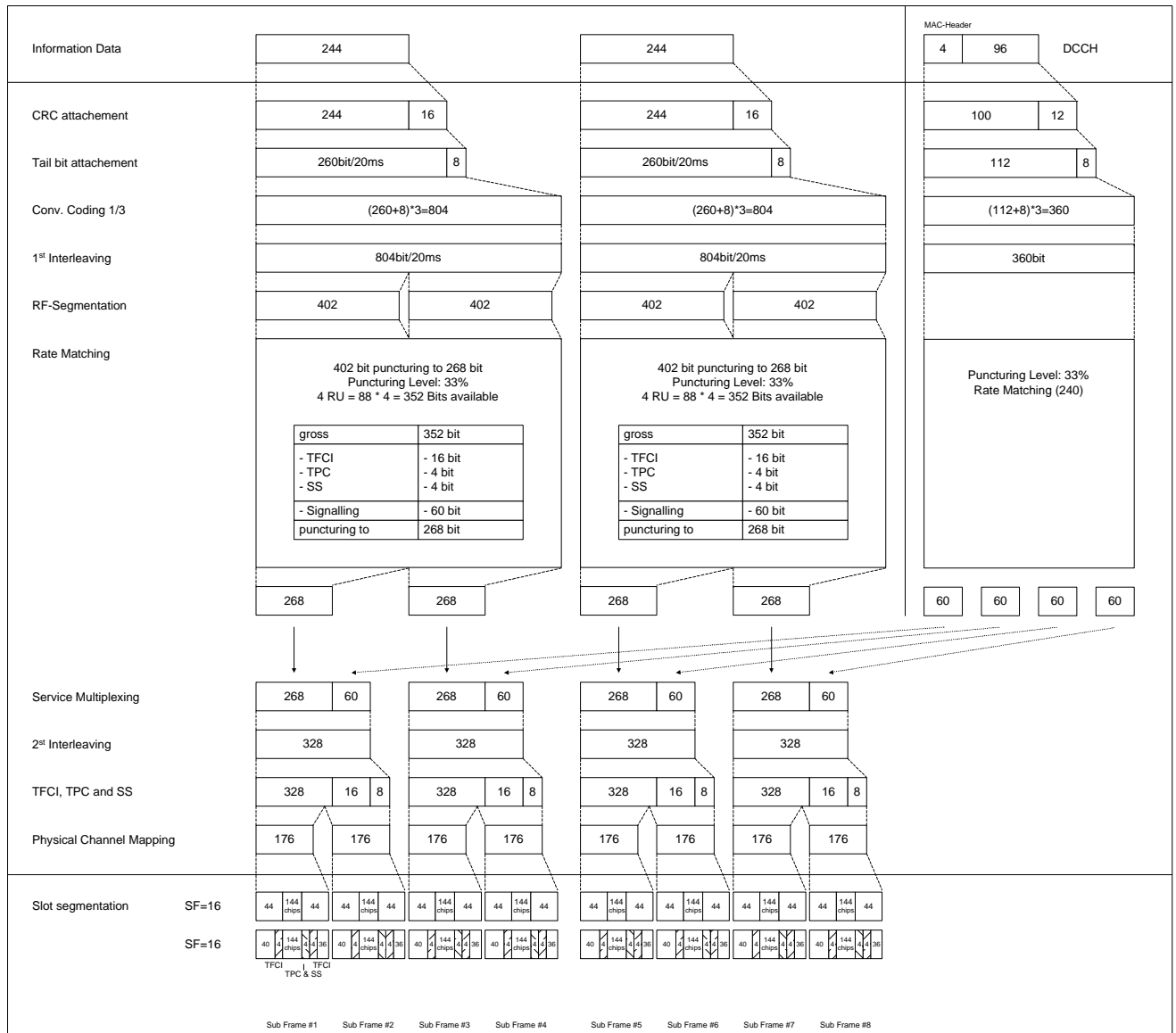

5.A.2.2 DL reference measurement channel (64 kbps)

Parameter	
Information data rate	64 kbps
RU's allocated	1TS (8*SF16) = 8RU/5ms
Midamble	144
Interleaving	20 ms
Power control (TPC)	4 Bit/user/10ms
TFCI	16 Bit/user/10ms

Synchronisation Shift (SS)	4 Bit/user/10ms
Inband signalling DCCH	2 kbps
Puncturing level at Code rate: 1/3 DCH / 1/2 DCCH	32% / 0

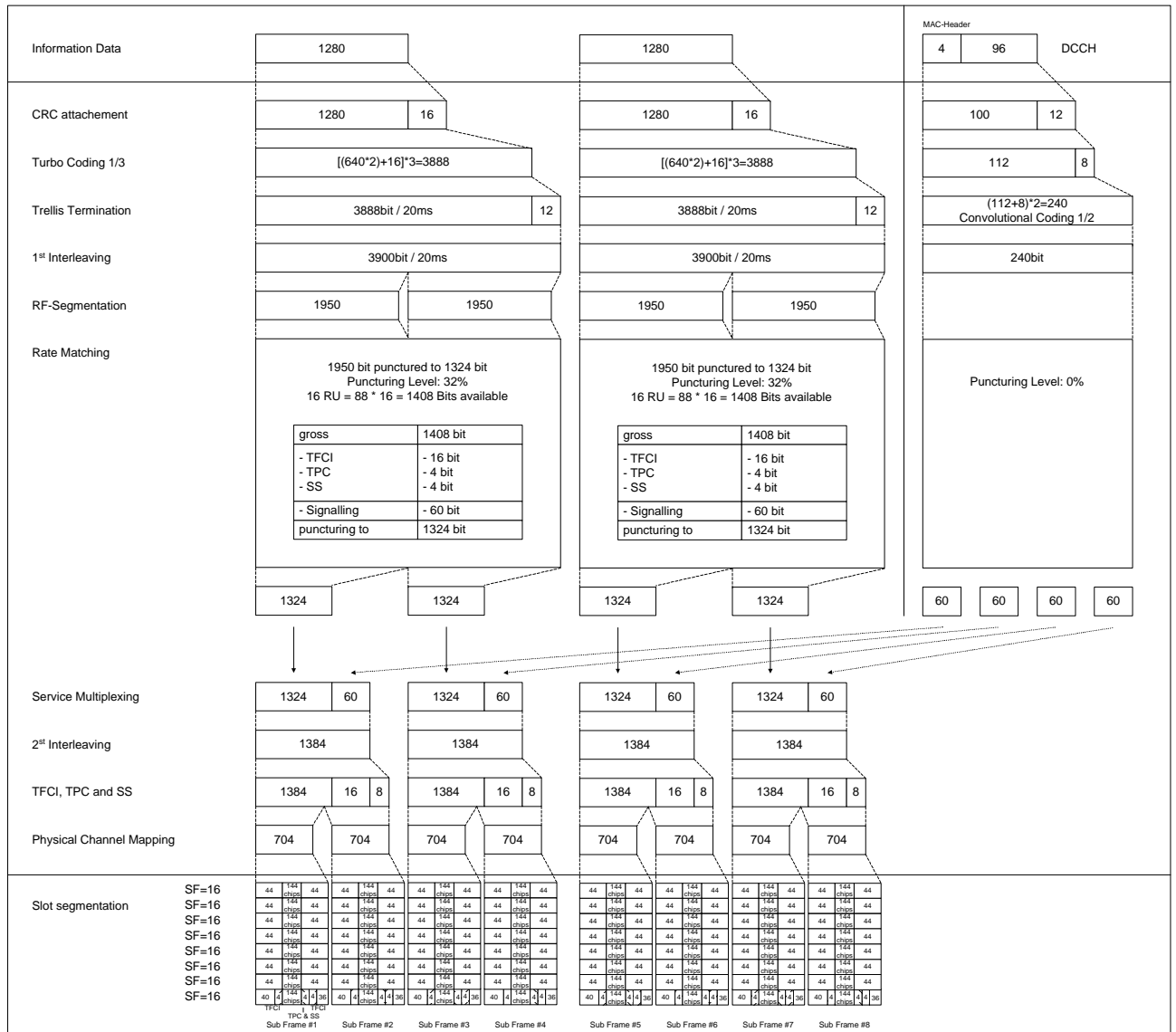

5.A.2.3 DL reference measurement channel (144 kbps)

Parameter	
-----------	--

Information data rate	144 kbps
RU's allocated	2TS (8*SF16) = 16RU/5ms
Midamble	144
Interleaving	20 ms
Power control (TPC)	8 Bit/user/10ms
TFCI	32 Bit/user/10ms
Synchronisation Shift (SS)	8 Bit/user/10ms
Inband signalling DCCH	2 kbps
Puncturing level at Code rate: 1/3 DCH / 1/2 DCCH	38% / 7%

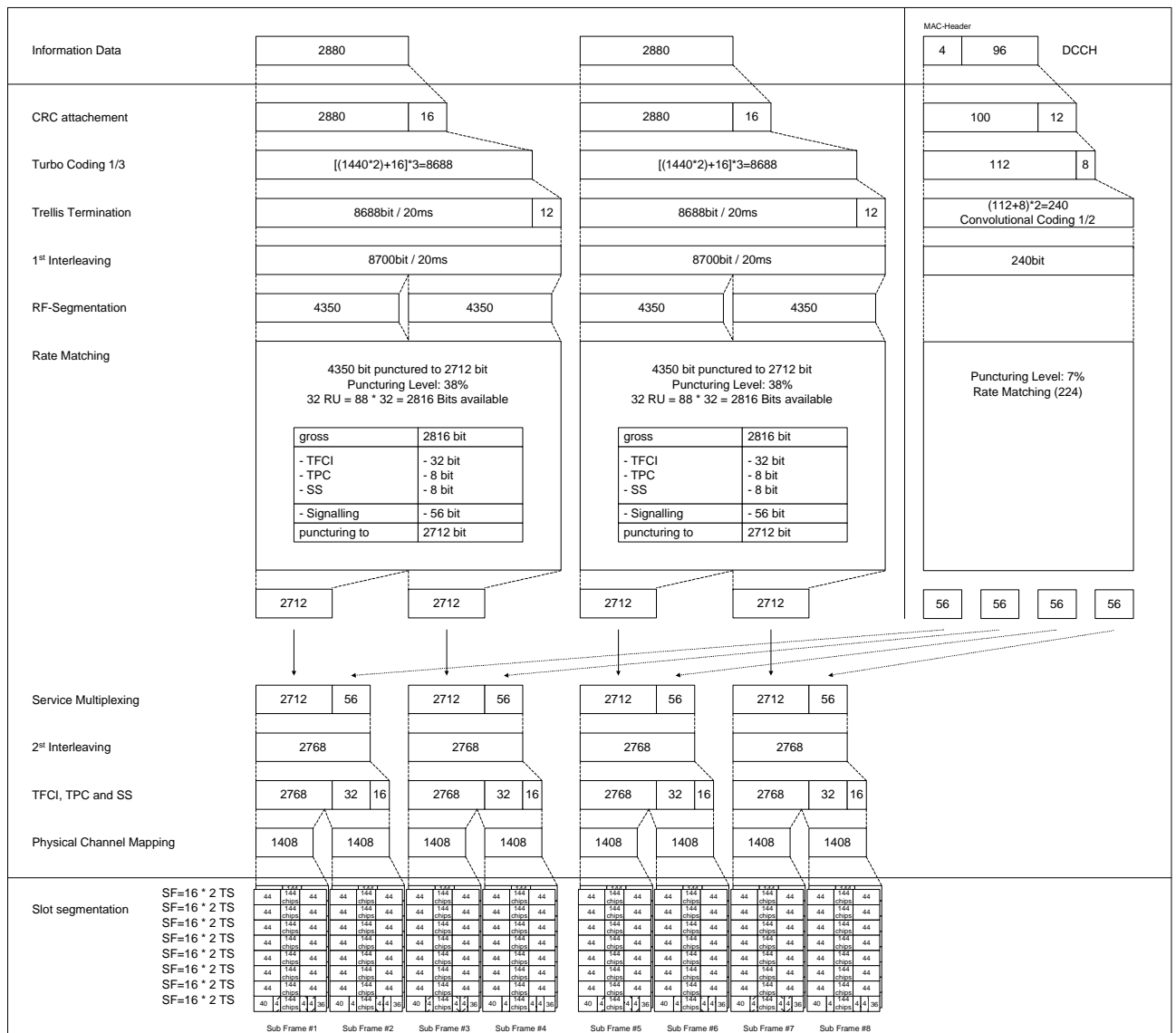

5.A.2.4 DL reference measurement channel (384 kbps)

Parameter	
Information data rate	384 kbps
RU's allocated	4TS (10*SF16) = 40RU/5ms
Midamble	144
Interleaving	20 ms
Power control (TPC)	16 Bit/user/10ms
TFCI	64 Bit/user/10ms
Synchronisation Shift (SS)	16 Bit/user/10ms
Inband signalling DCCH	2 kbps
Puncturing level at Code rate: 1/3 DCH / ½ DCCH	41% / 12%

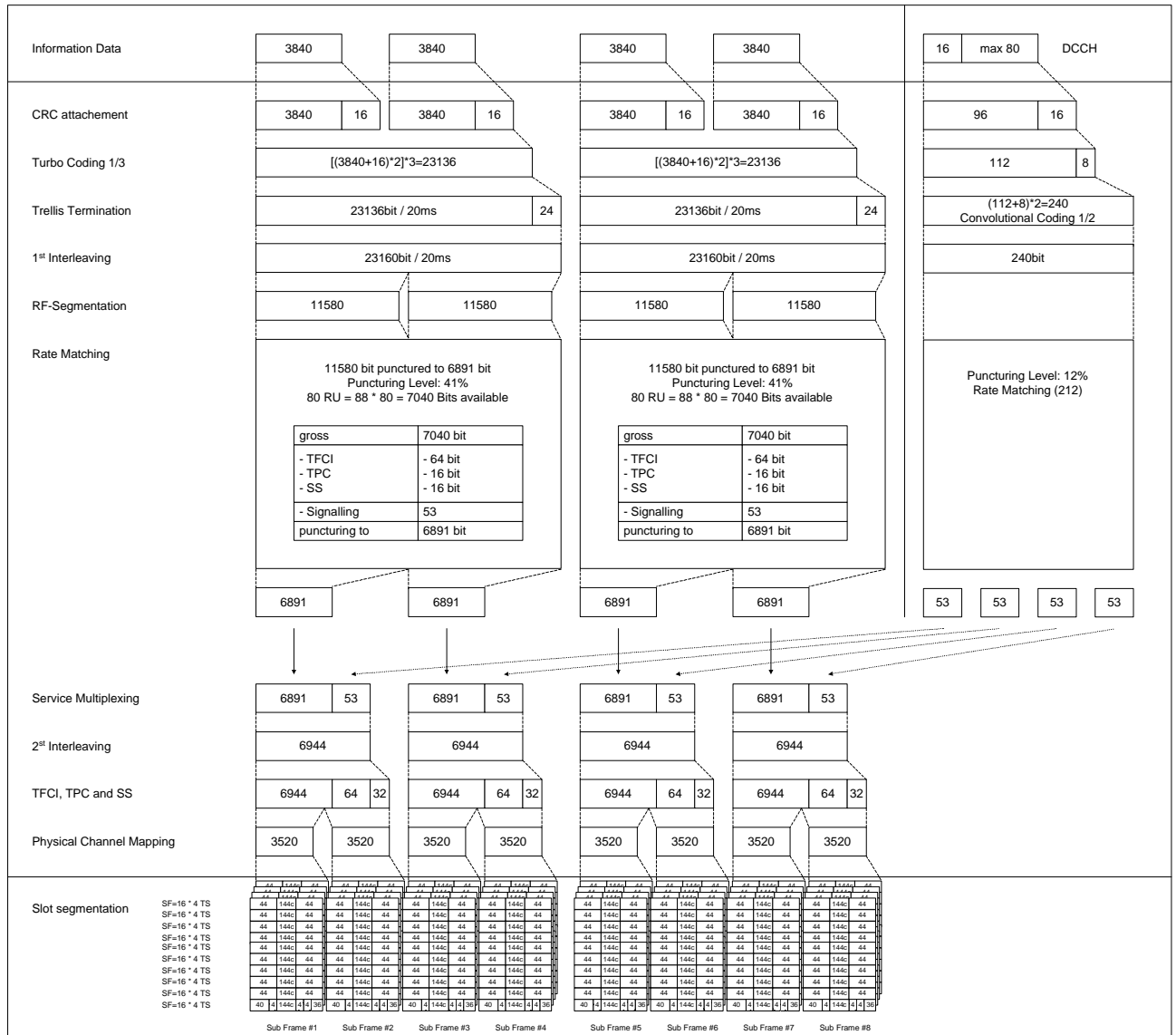

[Explanation difference:]

For the 1.28Mcps chip rate TDD option, one frame (10ms) consists of two sub-frames(5ms), and one

Sub-frame consists of 7 timeslots. The structure of timeslot in 1.28Mcps chip rate TDD (shown inTR25.928) is different from the structure of timeslot in 3.84Mcps TDD. So the service mapping of variance data rate of 1.28Mcps chip rate TDD option is different from that of 3.84Mcps chip rate TDD option.

Annex 5.B (normative): Propagation conditions

5.B.1 Static Propagation conditions

The propagation for the static performance measurement is an Additive White Gaussian Noise (AWGN) environment. No fading and multi-path exist for the propagation model.

5.B.2 multi-path fading Propagation conditions

Table 1 shows propagation conditions that are used for the performance measurements in multi-path fading environment. All taps have classical Doppler spectrum.

Table 1: Propagation Conditions for Multi-Path Fading Environments

Case 1, speed 3km/h		Case 2, speed 3km/h		Case 3, speed 120km/h	
Relative Delay [ns]	Average Power [dB]	Relative Delay [ns]	Average Power [dB]	Relative Delay [ns]	Average Power [dB]
0	0	0	0	0	0
2928	-10	2928	0	781	-3
		12000	0	1563	-6
				2344	-9

[Rationale]:

The channel estimation can only resolve paths with are separated by at least one chip in delay. Otherwise the paths fall into the same tap. Even though this happens in realistic environments, it is not useful to base the propagation models for the performance requirements on a scenario with a delay spread of less than 1 chip, because the baseband is not tested in this case. Therefore, it is proposed to keep the same delay for the path in units of chips for the 1.28Mcps chip rate TDD-mode as for the 3.84Mcps chip rate TDD-mode. The tap delays in units of time are changed accordingly to take into account the difference in the chip rate. Due to the request to have the same maximum delay spread for 1.28Mcps chip rate TDD as for 3.84Mcps chip rate TDD, the delay spread of tap 3rd for the case 2 propagation conditions is set to 12 ms.:

Annex 5.C (normative): Environmental conditions

5.C.1 General

This normative annex specifies the environmental requirements of the UE. Within these limits the

requirements of this specifications shall be fulfilled.

5.C.2 Environmental requirements for the UE

The requirements in this clause apply to all types of UE(s)

5.C.2.1 Temperature

The UE shall fulfil all the requirements in the full temperature range of:

+15°C – +35°C	for normal conditions (with relative humidity of 25 % to 75 %);
-10°C - +55°C	for extreme conditions (see IEC publications 68-2-1 and 68-2-2)

Outside this temperature range the UE, if powered on, shall not make ineffective use of the radio frequency spectrum. In no case shall the UE exceed the transmitted levels as defined in TR25.945 UE Section for extreme operation.

5.C.2.2 Voltage

The UE shall fulfil all the requirements in the full voltage range, i.e. the voltage range between the extreme voltages.

The manufacturer shall declare the lower and higher extreme voltages and the approximate shutdown voltage. For the equipment that can be operated from one or more of the power sources listed below, the lower extreme voltage shall not be higher, and the higher extreme voltage shall not be lower than that specified below.

Power source	Lower extreme voltage	Higher extreme voltage	Normal conditions voltage
AC mains	0,9 * nominal	1,1 * nominal	nominal
Regulated lead acid battery	0,9 * nominal	1,3 * nominal	1,1 * nominal
Non regulated batteries:			
- Leclanché/lithium	0,85 * nominal	Nominal	Nominal
- Mercury/nickel cadmium	0,90 * nominal	Nominal	Nominal

Outside this voltage range the UE if powered on, shall not make ineffective use of the radio frequency spectrum. In no case shall the UE exceed the transmitted levels as defined in TR25.945 UE section for extreme operation. In particular, the UE shall inhibit all RF transmissions when the power supply voltage is below the manufacturer declared shutdown voltage.

5.C.2.3 Vibration

The UE shall fulfil all the requirements when vibrated at the following frequency/amplitudes:

Frequency	ASD (Acceleration Spectral Density) random vibration
-----------	--

5 Hz to 20 Hz	0,96 m ² /s ³
20 Hz to 500 Hz	0,96 m ² /s ³ at 20 Hz, thereafter -3 dB/Octave

Outside the specified frequency range the UE, if powered on, shall not make ineffective use of the radio frequency spectrum. In no case shall the UE exceed the transmitted levels as defined in TR25.945 UE section for extreme operation.

[Rationale:]

The environmental conditions of UE specification is kept in line with 3.84Mcps TDD, because these specification do not consider the bandwidth of the signal nor any other difference between 3.84Mcps TDD and 1.28Mcps TDD.

6 BS radio transmission and reception

6.1 Frequency bands and channel arrangement

6.1.1 General

The information presented in this section is based on a chip rate of 1,28Mcps.

6.1.2 Frequency bands

Common with 3,84Mcps TDD option.

6.1.3 TX–RX frequency separation

[Description:]

No TX-RX frequency separation is required as Time Division Duplex (TDD) is employed. Each subframe of 1.28Mcps TDD consists of 7 main timeslots where all main timeslots (at least the first one) before the single switching point are allocated DL and all main timeslots (at least the last one) after the single switching point are allocated UL.

[Explanation of difference:]

The frame structure for 3.84Mcps TDD and 1.28Mcps TDD is different. For 3.84 Mcps TDD, each TDMA frame consists of 15 timeslots where each timeslot can be allocated to either transmit or receive.

6.1.4 Channel arrangement

6.1.4.1 Channel spacing

6.1.4.1.1 Background

The roll filter factor is would be 0.22, then we select the nominal bandwidth as 1.6MHz;
Considering the easy co-existence with Wide-band TDD mode, for its 3 times bandwidth would be 4.8, less than the nominal bandwidth of wide band UTRA TDD;
It is just nominal for 1.6MHz, and it is also flexible to adjust the channel raster step 200kHz to narrow as 1.4MHz for strict requirement situations if needed;
Considering the easy to implementation, for too narrow band of the bandwidth would be very difficult to implementation.

6.1.4.1.2 Channel spacing

The channel spacing for 1.28Mcps chip rate option is 1.6MHz.

6.1.4.2 Channel raster

Common with 3,84Mcps TDD option.

6.1.4.3 Channel number

Common with 3,84Mcps TDD option.

6.2 Transmitter characteristics

6.2.1 General

Common with 3,84Mcps TDD option.

6.2.2 Base station output power

Common with 3,84Mcps TDD option.

6.2.2.1 Base station maximum output power

Common with 3,84Mcps TDD option.

6.2.2.1.1 Minimum requirement

Common with 3,84Mcps TDD option.

6.2.3 Frequency stability

Common with 3,84Mcps TDD option.

6.2.4 Output power dynamics

Common with 3,84Mcps TDD option.

6.2.4.1 Inner loop power control

Common with 3,84Mcps TDD option.

6.2.4.2 Power control steps

Common with 3,84Mcps TDD option.

6.2.4.2.1 Minimum requirement

Common with 3,84Mcps TDD option.

6.2.4.3 Power control dynamic range

Common with 3,84Mcps TDD option.

6.2.4.3.1 Minimum requirement

Common with 3,84Mcps TDD option.

6.2.4.4 Minimum transmit power

Common with 3,84Mcps TDD option.

6.2.4.4.1 Minimum requirement

Common with 3,84Mcps TDD option.

6.2.4.5 Primary CCPCH power

Common with 3,84Mcps TDD option.

6.2.5 Transmit ON/OFF power

6.2.5.1 Transmit OFF power

The transmit OFF power state is when the BS does not transmit. This parameter is defined as maximum output transmit power within the channel bandwidth when the transmitter is OFF.

6.2.5.1.1 Minimum Requirement

The requirement of transmitOFF power shall be better than -82 dBm measured with a filter that has a Root Raised Cosine (RRC) filter response with a roll off $\alpha=0.22$ and a bandwidth equal to the chip rate.

[Rationale:]

Assuming the Noise Figure(NF) of BS is 7dB and Minimum Couple Loss(MCL) is 30dB. For the victim receiver ,the Tx OFF power should not exceed the thermal noise. If Tx OFF power is 6dB below thermal noise, it will introduce 1dB degradation. The proposal for Tx OFF power is as follows:

$$P_N = -174 \text{ dBm/Hz} + 10\log(1.28 \text{ MHz/Hz}) + \text{NF}(7 \text{ dB}) = -106 \text{ dBm}$$

$$P_{Tx_OFF} \leq P_N - 6\text{dB} + MCL = -106 - 6 + 30 = -82\text{dBm}$$

Note: In 1.28Mcps TDD option, The noise figure of BS is assumed to be 7dB, it is based on that this parameter has been approved by CWTS yet and it is easier for implementation of BS.

6.2.5.2 Transmit ON/OFF Time mask

6.2.6 Output RF spectrum emissions

6.2.6.1 Occupied bandwidth

[Description:]

Occupied bandwidth is a measure of the bandwidth containing 99% of the total integrated power for transmitted spectrum and is centered on the assigned channel frequency. The occupied channel bandwidth is about 1.6 MHz based on a chip rate of 1.28 Mcps.

[Explanation of difference:]

In 3.84Mcps TDD, the occupied channel bandwidth is less than 5MHz based on 3.84Mcps. But in 1.28Mcps TDD, as the background analysis in WG4#12 Meeting Tdoc515, which has been accepted to into the TR25.945, the occupied channel bandwidth should be less than 1.6 MHz based on 1.28 Mcps.

6.2.6.2 Out of band emission

6.2.6.2.1 Spectrum emission mask

Table 6.2.6.2-1: BS Spectrum Emission Mask Requirement(1.28Mcps chip rate)

Frequency offset from carrier Δf	Maximum level	Measurement bandwidth
0.8 – 1.12 MHz	[-22]dBm	30 kHz *
1.12 - 2.4 MHz		[0.3] MHz *
2.4 – 2.72 MHz	[-21]dBm	[0.3] MHz *
2.72 – 4.0 MHz	[-25]dBm	[0.3] MHz *

Note

The first and last measurement position with a 30 kHz filter is 0.815 MHz and 1.105 MHz

The first and last measurement position with a [0.3] MHz filter is 1.27 MHz and 4 MHz

6.2.6.2.2 Adjacent Channel Leakage power Ratio(ACLR)

For the 1.28Mcps chip rate option, the ACLR shall be better than the value specified in the following Table.

Table 6.2.6.2.2-1 : BS ACLR (1.28Mcps chip rate)

BS adjacent channel offset	ACLR limit
± 1.6 MHz	[40] dB
± 3.2 MHz	[50] dB

6.2.6.3 Spurious emissions

Common with 3.84Mcps option.

6.2.6.3.1 Mandatory Requirements

The requirements of either subclause 6.2.6.3.1.1 or subclause 6.2.6.3.1.2 shall apply whatever the type of transmitter considered (single carrier or multi-carrier). It applies for all transmission modes foreseen by the manufacturer's.

Either requirement applies at frequencies within the specified frequency ranges which are more than 4MHz under the first carrier frequency used or more than 4 MHz above the last carrier frequency used.

[Explanation of difference]

In 3.84Mcps option, the frequency offset from carrier frequency is greater than 12.5MHz, while in 1.28Mcps option it is greater than 4 MHz.

In ITU specification, the frequency limit between out of band emissions and spurious emissions is defined as 250% of the necessary bandwidth. In 1.28Mcps option the necessary bandwidth is 1.6MHz, so the frequency offset from carrier frequency is $250 \% \times 1.6 MHz = 4 MHz$.

6.2.6.3.1.1 Spurious emissions (Category A)

Common with 3.84Mcps option.

6.2.6.3.1.2 Spurious emissions (Category B)

The following requirements shall be met in cases where Category B limits for spurious emissions, as defined in ITU-R Recommendation SM.329-7, are applied.

6.2.6.3.1.2.1 Minimum Requirement

The power of any spurious emission shall not exceed:

Table 6.2.6.3.1.2.1 BS Mandatory spurious emissions limits, Category B

Band	Maximum Level	Measurement Bandwidth	Note
9kHz – 150kHz	-36 dBm	1 kHz	Bandwidth as in ITU SM.329-7, s4.1
150kHz – 30MHz	- 36 dBm	10 kHz	Bandwidth as in ITU SM.329-7, s4.1
30MHz – 1GHz	-36 dBm	100 kHz	Bandwidth as in ITU SM.329-7, s4.1
1GHz ↔ Fc1-19.2 MHz or Fl -3.2 MHz <i>whichever is the higher</i>	-30 dBm	1 MHz	Bandwidth as in ITU SM.329-7, s4.1
Fc1 – 19.2 MHz or Fl -3.2MHz <i>whichever is the higher</i> ↔ Fc1 - 16 MHz or Fl -3.2 MHz <i>whichever is the higher</i>	-25 dBm	1 MHz	Specification in accordance with ITU-R SM.329-7, s4.1
Fc1 - 16 MHz or Fl -3.2 MHz <i>whichever is the higher</i> ↔ Fc2 + 16 MHz or Fu +3.2 MHz <i>whichever is the lower</i>	-15 dBm	1 MHz	Specification in accordance with ITU-R SM.329-7, s4.1
Fc2 + 16 MHz or Fu + 3.2MHz <i>whichever is the lower</i> ↔ Fc2 +19.2 MHz or Fu + 3.2MHz <i>whichever is the lower</i>	-25 dBm	1 MHz	Specification in accordance with ITU-R SM.329-7, s4.1
Fc2 + 19.2 MHz or Fu +3.2 MHz <i>whichever is the lower</i> ↔ 12,5 GHz	-30 dBm	1 MHz	Bandwidth as in ITU-R SM.329-7, s4.1. Upper frequency as in ITU-R SM.329-7, s2.6

Fc1: Center frequency of emission of the first carrier transmitted by the BS

Fc2: Center frequency of emission of the last carrier transmitted by the BS

F_l : Lower frequency of the band in which TDD operates

F_u : Upper frequency of the band in which TDD operates

6.2.6.3.2 Co-existence with GSM 900

Common with 3,84Mcps TDD option.

6.2.6.3.2.1 Operation in the same geographic area

Common with 3,84Mcps TDD option.

6.2.6.3.2.1.1 Minimum requirement

Common with 3,84Mcps TDD option.

6.2.6.3.2.2 Co-located base stations

Common with 3,84Mcps TDD option.

6.2.6.3.2.2.1 Minimum requirement

Common with 3,84Mcps TDD option.

6.2.6.3.3 Co-existence with DCS 1800

Common with 3,84Mcps TDD option.

6.2.6.3.3.1 Operation in the same geographic area

Common with 3,84Mcps TDD option.

6.2.6.3.3.1.1 Minimum requirement

Common with 3,84Mcps TDD option.

6.2.6.3.3.2 Co-located base stations

Common with 3,84Mcps TDD option.

6.2.6.3.3.2.1 Minimum requirement

Common with 3,84Mcps TDD option.

6.2.6.3.4 Co-existence with UTRA FDD

Common with 3,84Mcps TDD option.

6.2.6.3.4.1 Operation in the same geographic area

Common with 3,84Mcps TDD option.

6.2.6.3.4.1.1 Minimum requirement

Common with 3,84Mcps TDD option.

6.2.6.3.4.2 Co-located base stations

Common with 3,84Mcps TDD option.

6.2.6.3.4.2.1 Minimum requirement

Common with 3,84Mcps TDD option.

6.2.7 Transmit intermodulation

The transmit intermodulation performance is a measure of the capability of the transmitter to inhibit the generation of signals in its non linear elements caused by presence of the wanted signal and an interfering signal reaching the transmitter via the antenna.

The transmit intermodulation level is the power of the intermodulation products when a CDMA modulated interference signal is injected into the antenna connector at a level of 30 dB lower than that of the subject signal. The frequency of the interference signal shall be ± 1.6 MHz, ± 3.2 MHz and ± 4.8 MHz offset from the subject signal.

[Explanation of difference:]

In 1.28Mcps option, the necessary bandwidth is 1.6MHz. The frequency of interference signal is $1*NB, 2*NB$ and $3*NB$ offset from the subject, that means ± 1.6 MHz, ± 3.2 MHz and ± 4.8 MHz.

In 3.84Mcps option, the necessary bandwidth is 5 MHz. So the frequency of interference signal is ± 5 MHz, ± 10 MHz and ± 15 MHz offset from subject signal.

6.2.7.1 Minimum requirement

The Transmit intermodulation level shall not exceed the out of band or the spurious emission requirements of section 6.2.6.2 and 6.2.6.3 in TR25.945.

6.2.8 Transmit modulation

6.2.8.1 Transmit pulse shape filter

The transmit pulse-shaping filter is a root-raised cosine (RRC) with roll-off $\alpha = 0.22$ in the frequency domain. The impulse response of the chip impulse filter $RC_0(t)$ is

$$RC_0(t) = \frac{\sin\left(\pi \frac{t}{T_C}(1-\alpha)\right) + 4\alpha \frac{t}{T_C} \cos\left(\pi \frac{t}{T_C}(1+\alpha)\right)}{\pi \frac{t}{T_C} \left(1 - \left(4\alpha \frac{t}{T_C}\right)^2\right)}$$

Where the roll-off factor $\alpha = 0.22$ and the chip duration: $T_C = \frac{1}{\text{chiprate}} = 0.78125\mu s$

[Explanation of difference:]

The chip rate for 1.28Mcps TDD option is 1.28Mcps, the chip duration is

$T_C = \frac{1}{\text{chiprate}} = 0.78125\mu\text{s}$. While in 3.84 Mcps TDD option, the chip rate is 3.84Mcps, the

duration is $T_c = \frac{1}{\text{chiprate}} \approx 0.26042\mu\text{s}$.

6.2.8.2 Modulation Accuracy

Common with 3.84Mcps TDD option.

6.2.8.2.1 Minimum Requirement

Common with 3.84Mcps TDD option.

6.2.8.3 Peak Code Domain Error

Common with 3.84Mcps TDD option.

6.2.8.3.1 Minimum Requirement

Common with 3.84Mcps TDD option.

[Rationale:]

For 3.84Mcps TDD and FDD, the minimum requirements for the error vector magnitude and peak code domain error ensures that the error vector magnitude does not degrade the performance the error vector magnitude leads only to low increase for the transmitted output power to remain the E_b/N_0

The theoretical investigations have shown that the error vector magnitude is related to the spreading factor. Because the same spreading factors are used for 1.28Mcps TDD and for 3.84Mcps TDD, the same minimum requirement applies.

6.3 Receiver characteristics

6.3.1 General

Common with 3,84Mcps TDD option.

6.3.2 Reference sensitivity level

The reference sensitivity is the minimum receiver input power measured at the antenna connector at which the FER/BER does not exceed the specific value indicated in section 6.3.2.1.

6.3.2.1 Minimum Requirement

For the measurement channel specified in the Annex6.A: *Measurement Channel*, the reference sensitivity level and performance of the BS shall be as specified in table 6.3.2-1 below.

Table 6.3.2-1: BS reference sensitivity levels

Data rate	BS reference sensitivity level (dBm)	FER/BER
12.2 kbps	-110 dBm	BER shall not exceed 0.001

[Rationale:]

The reference sensitivity value of BS for 1.28Mcps TDD is derived from the following formula. Assuming the noise figure(NF) of BS is 7dB, the noise floor is:

$$P_N = -174 \text{ dBm/Hz} + 10\log(1.28 \text{ MHz/Hz}) + \text{NF}(7 \text{ dB}) = -106 \text{ dBm}$$

According to the simulation results for 12.2Kbps measurement channel, the BER=0.001 is achieved at $\hat{I}_{or}/I_{oc} = 1.2\text{dB}$. In simulation, assume \hat{I}_{or} equal to I_{or} , we can get:

$$\frac{DPCH - E_c}{I_{oc}} = \frac{DPCH - E_c}{I_{or}} \frac{\hat{I}_{or}}{I_{oc}} = -7 \text{ dB} + 1.2\text{dB} = -5.8 \text{ dB}$$

The sensitivity value without implementation is calculated as follows:

$$P_s = \frac{DPCH - E_c}{I_{oc}} P_N = -106 \text{ dBm} - 5.8\text{dB} = -111.8\text{dBm}$$

If the implementation margin is considered to be 1.5dB, the final sensitivity value is:

$$P_s = -111.8 \text{ dBm} + \text{margin} = -110.3\text{dBm}$$

The reference sensitivity value of -110dBm is proposed to the BS specification for 1.28Mcps TDD .

Note: In 1.28Mcps TDD option, The noise figure of BS is assumed to be 7dB, it is based on that this parameter has been approved by CWTS yet and it is easier for implementation of BS.

[Simulation results:]

The simulation is done to 12.2kb/s data in static propagation condition for BS of 1.28Mcps TDD. The service-mapping is specified in Annex6.A: *Measurement Channel*, and the simulation assumption is specified in “*Simulation Assumption for 1.28Mcps Chip Rate TDD option*”.

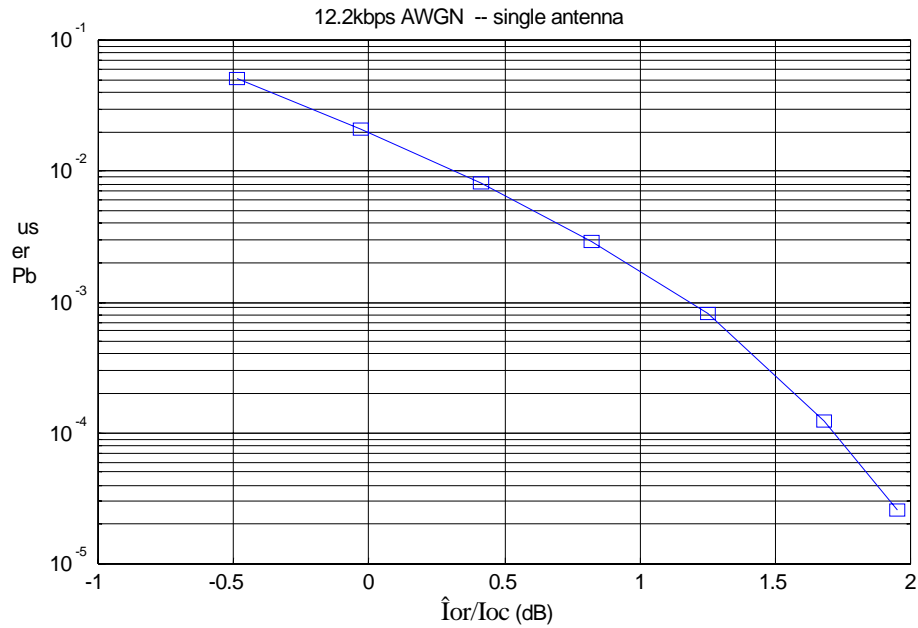

\hat{I}_{or}/I_{oc} P_b

-0.49	5.09E-2
-0.03	2.12E-2
0.41	8.11E-3
0.82	2.90E-3
1.25	8.12E-4
1.68	1.23E-4
1.95	2.61E-5

6.3.2.2 Maximum Frequency Deviation for Receiver Performance

The need for such a requirement is for further study.

6.3.3 Dynamic range

Receiver dynamic range is the receiver ability to handle a rise of interference in the reception

frequency channel. The receiver shall fulfil a specified BER requirement for a specified sensitivity degradation of the wanted signal in the presence of an interfering AWGN signal in the same reception frequency channel.

6.3.3.1 Minimum requirement

The BER shall not exceed 0.001 for the parameters specified in Table 6.3.3-1.

Table 6.3.3-1: Dynamic Range

Parameter	Level	Unit
Data rate	12.2	kbps
Wanted signal	<REFSENS> + 30 dB	dBm
Interfering AWGN signal	-76dBm	dBm/1.28 MHz

[Rationale:]

When wanted signal level is 30 dB above the reference sensitivity level, in order to keep the performance of $BER \leq 0.001$ the maximum interfering signal P_I needs meet the following requirement:

$$\begin{aligned}
 P_I &\leq \text{noise floor [dBm]} + \text{noise figure [dB]} + 30 \text{ dB} \\
 &= -113 \text{ dBm} + 7 \text{ dB} + 30 \text{ dB} \\
 &= -76 \text{ dBm}
 \end{aligned}$$

It is also proposed to the BS conformance test, the section 8.4.3 in TR25.945.

Note: In 1.28Mcps TDD option, The noise figure of BS is assumed to be 7dB, it is based on that this parameter has been approved by CWTS yet and it is easier for implementation of BS.

6.3.4 Adjacent Channel Selectivity (ACS)

Adjacent channel selectivity (ACS) is a measure of the receiver ability to receive a wanted signal at its assigned channel frequency in the presence of an adjacent channel signal at a given frequency offset from the center frequency of the assigned channel. ACS is the ratio of the receiver filter attenuation on the assigned channel frequency to the receive filter attenuation on the adjacent channel(s).

6.3.4.1 Minimum Requirement

The BER shall not exceed 0.001 for the parameters specified in table 6.3.4-1.

Table 6.3.4-1 : Adjacent channel selectivity

Parameter	Level	Unit
Data rate	12.2	kbps
Wanted signal	Reference sensitivity level + 6dB	dBm

Interfering signal	[-55]	dBm
Fuw (Modulated)	1.6	MHz

[Rationale:]

Assuming the receiver filter ACS equals to 45 dBc, in order to keep the performance of BER, the interference signal level P_I should meet the following requirement:

$$\begin{aligned}
 P_I &\leq \text{noise floor [dBm]} + \text{noise figure [dB]} + 6 \text{ dB (because the wanted signal is 6 dB above sensitivity)} + \text{ACS} \\
 &= -113 \text{ dBm} + 7 \text{ dB} + 6 \text{ dB} + 45 \text{ dBc} \\
 &= -55 \text{ dBm}
 \end{aligned}$$

Note: In 1.28Mcps TDD option, The noise figure of BS is assumed to be 7dB, it is based on that this parameter has been approved by CWTS yet and it is easier for implementation of BS.

6.3.5 Blocking characteristics

6.3.5.1 Minimum Requirements

For the 1.28Mcps chip rate option, the requirement of Blocking for carrier spacing 1.6MHz is prescribed in the following table.

Table 6.3.5-1 (a): Blocking requirements for operating bands defined in 6.1.2(a)

Center Frequency of Interfering Signal	Interfering Signal Level	Wanted Signal Level	Minimum Offset of Interfering Signal	Type of Interfering Signal
1900 – 1920 MHz, 2010 – 2025 MHz	[-40] dBm	<REFSENS> + 6 dB	[3.2]MHz	Narrow band CDMA signal with one code
1880 – 1900 MHz, 1990 – 2010 MHz, 2025 – 2045 MHz	[-40] dBm	<REFSENS> + 6 dB	[3.2]MHz	Narrow band CDMA signal with one code
1920 – 1980 MHz	[-40] dBm	<REFSENS> + 6 dB	[3.2]MHz	Narrow band CDMA signal with one code
1 – 1880 MHz, 1980 – 1990 MHz, 2045 – 12750 MHz	[-15] dBm	<REFSENS> + 6 dB	—	CW carrier

Table 6.3.5-1(b) : Blocking requirements for operating bands defined in 6.1.2(b)

Center Frequency of Interfering Signal	Interfering Signal Level	Wanted Signal Level	Minimum Offset of Interfering Signal	Type of Interfering Signal
1850 – 1990 MHz	[-40] dBm	<REFSENS> + 6 dB	[3.2]MHz	Narrow band CDMA signal with one code
1830 – 1850 MHz, 1990 – 2010 MHz	[-40] dBm	<REFSENS> + 6 dB	[3.2]MHz	Narrow band CDMA signal with one code
1 – 1830 MHz, 2010 – 12750 MHz	[-15] dBm	<REFSENS> + 6 dB	—	CW carrier

Table 6.3.5-1(c) : Blocking requirements for operating bands defined in 6.1.2(c)

Center Frequency of Interfering Signal	Interfering Signal Level	Wanted Signal Level	Minimum Offset of Interfering Signal	Type of Interfering Signal
1910 – 1930 MHz	[-40] dBm	<REFSENS> + 6 dB	[3.2]MHz	Narrow band CDMA signal with one code
1890 – 1910 MHz, 1930 – 1950 MHz	[-40] dBm	<REFSENS> + 6 dB	[3.2]MHz	Narrow band CDMA signal with one code
1 – 1890 MHz, 1950 – 12750 MHz	[-15] dBm	<REFSENS> + 6 dB	—	CW carrier

6.3.6 Intermodulation characteristics

Third and higher order mixing of the two interfering RF signals can produce an interfering signal in the band of the desired channel. Intermodulation response rejection is a measure of the capability of the receiver to receiver a wanted signal on its assigned channel frequency in the presence of two or more interfering signals which have a specific frequency relationship to the wanted signal.

The static reference performance as specified in clause 6.3.2.1 should be met when the following signals are coupled to BS antenna input.

A wanted signal at the assigned channel frequency, 6 dB above the static reference level.

Two interfering signals with the following parameters.

Table 6.3.6-1: Intermodulation requirement (1.28Mcps chiprate)

Interfering Signal Level	Offset	Type of Interfering Signal
- 48 dBm	3.2 MHz	CW signal
- 48 dBm	6.4 MHz	Narrow band CDMA signal with one code

[Rationale:]

Intermodulation characteristics mean the BS receiver needs to have a sufficient capability to reject the interfering signals. Same frequency bands is applied for 1.28Mcps and 3.84Mcps TDD, therefore 1.28Mcps TDD should be resistant to the same level of interfering signals at other frequencies. The level –48dBm is proposed for interfering signals without brackets.

6.3.7 Spurious emissions

The spurious emissions power is the power of emissions generated or amplified in a receiver that appear at the BS antenna connector. The requirements apply to all BS with separate RX and TX antenna port. The test shall be performed when both TX and RX are on with the TX port terminated.

For all BS with common RX and TX antenna port the transmitter spurious emission as specified in section 6.2.6.3 is valid.

6.3.7.1 Minimum Requirement

The power of any spurious emission shall not exceed:

Table 6.3.7-1 : Receiver spurious emission requirements

Band	Maximum level	Measurement Bandwidth	Note
9 kHz – 1 GHz	-57 dBm	100 kHz	
1 GHz – 1.9 GHz and 1.98 GHz – 2.01 GHz	-47 dBm	1 MHz	With the exception of frequencies between 4MHz below the first carrier frequency and 4MHz above the last carrier frequency used by the BS.
1.9 GHz – 1.98 GHz and 2.01 GHz – 2.025 GHz	-83 dBm	1.28 MHz	With the exception of frequencies between 4MHz below the first carrier frequency and 4MHz above the last carrier frequency used by the BS.
2.025 GHz – 12.75 GHz	-47 dBm	1 MHz	With the exception of frequencies between 4MHz below the first carrier frequency and 4MHz above the last carrier frequency used by the BS.

[Rationale:]

Assuming the Minimum Couple Loss (MCL) is 30dB. For the victim receiver, the spurious emissions power generated by the BS receiver should not exceed the thermal noise. . The proposal for spurious emission power that located in the 1.9 GHz – 1.98 GHz and 2.01 GHz – 2.025 GHz band is as follows:

$$P_N = -174 \text{ dBm/Hz} + 10\log(1.28 \text{ MHz/Hz}) = -113 \text{ dBm}$$

$$P_{\text{Spurious}} \leq P_N + MCL = -113 + 30 = -83 \text{ dBm}$$

This leads to the same requirement as for 3.84 Mcps TDD. The different value is only due to the 1.28 MHz measurement bandwidth.

6.4 Performance requirement

6.4.1 General

Performance requirements for the BS are specified for the measurement channels defined in Annex 6.A and the propagation conditions in Annex 6.B. The requirements only apply to those measurement channels that are supported by the base station.

The requirements only apply to a base station with dual receiver antenna diversity. The required \hat{I}_{or}/I_{oc} shall be applied separately at each antenna port.

Table 6.4.1: Summary of Base Station performance targets

Physical channel	Measurement channel	Static	Multi-path Case 1	Multi-path Case 2	Multi-path Case 3
		Performance metric			
DCH	12.2 kbps	BLER < 10^{-2}	BLER < 10^{-2}	BLER < 10^{-2}	BLER < 10^{-2}
	64 kbps	BLER < $10^{-1}, 10^{-2}$	BLER < $10^{-1}, 10^{-2}$	BLER < $10^{-1}, 10^{-2}$	BLER < $10^{-1}, 10^{-2}, 10^{-3}$
	144 kbps	BLER < $10^{-1}, 10^{-2}$	BLER < $10^{-1}, 10^{-2}$	BLER < $10^{-1}, 10^{-2}$	BLER < $10^{-1}, 10^{-2}, 10^{-3}$
	384 kbps	BLER < $10^{-1}, 10^{-2}$	BLER < $10^{-1}, 10^{-2}$	BLER < $10^{-1}, 10^{-2}$	BLER < $10^{-1}, 10^{-2}, 10^{-3}$

6.4.2 Demodulation in static propagation conditions

6.4.2.1 Demodulation of DCH

The performance requirement of DCH in static propagation conditions is determined by the maximum Block Error Rate (BLER) allowed when the receiver input signal is at a specified \hat{I}_{or}/I_{oc} limit. The BLER is calculated for each of the measurement channels supported by the base station.

6.4.2.2.1.1 Minimum requirement

For the parameters specified in Table 6.4.2 the BLER should not exceed the piece-wise linear BLER curve specified in Table 6.4.3.

Table 6.4.2: Parameters in static propagation conditions

Parameters	Unit	Test 1	Test 2	Test 3	Test 4
Number of DPCH _o		4	1	1	0
Spread factor of DPCH _o		8	8	8	-
$\frac{DPCH_o - E_c}{I_{or}}$	DB	-7	-7	-7	0
I _{oc}	DBm/1.28MHz	-91			
Information Data Rate	Kbps	12.2	64	144	384

Table 6.4.3: Performance requirements in AWGN channel.

Test Number	$\frac{\hat{I}_{or}}{I_{oc}}$ [dB]	BLER Required E _b /N ₀
1		10^{-2}
2		10^{-1}
		10^{-2}
3		10^{-1}

		10^{-2}
4		10^{-1}
		10^{-2}

6.4.3 Demodulation of DCH in multipath fading conditions

6.4.3.1 Multipath fading Case 1

The performance requirement of DCH in multipath fading Case 1 is determined by the maximum Block Error Rate (BLER) allowed when the receiver input signal is at a specified \hat{I}_{or}/I_{oc} limit. The BLER is calculated for each of the measurement channels supported by the base station.

6.4.3.1.1 Minimum requirement

For the parameters specified in Table 6.4.4 the BLER should not exceed the piece-wise linear BLER curve specified in Table 6.4.5.

Table 6.4.4: Parameters in multipath Case 1 channel

Parameters	Unit	Test 1	Test 2	Test 3	Test 4
Number of DPCH _o		4	1	1	0
Spread factor of DPCH _o		8	8	8	-
$\frac{DPCH_o - E_c}{I_{or}}$	DB	-7	-7	-7	0
I_{oc}	dBm/1.28 MHz	-91			
Information Data Rate	Kbps	12.2	64	144	384

Table 6.4.5: Performance requirements in multipath Case 1 channel.

Test Number	$\frac{\hat{I}_{or}}{I_{oc}}$ [dB]	BLER
1		10^{-2}
2		10^{-1}
		10^{-2}
3		10^{-1}
		10^{-2}
4		10^{-1}
		10^{-2}

6.4.3.2 Multipath fading Case 2

The performance requirement of DCH in multipath fading Case 2 is determined by the maximum Block Error Rate (BLER) allowed when the receiver input signal is at a specified \hat{I}_{or}/I_{oc} limit. The BLER is calculated for each of the measurement channels supported by the base station.

6.4.3.2.1 Minimum requirement

For the parameters specified in Table 6.4.6 the BLER should not exceed the piece-wise linear BLER curve specified in Table 6.4.7.

Table 6.4.6: Parameters in multipath Case 2 channel

Parameters	Unit	Test 1	Test 2	Test 3	Test 4
Number of DPCH _o		4	1	1	0
Spread factor of DPCH _o		8	8	8	-
$\frac{DPCH_o - E_c}{I_{or}}$	DB	-7	-7	-7	0
I _{oc}	dBm/1.28 MHz	-91			
Information Data Rate	Kbps	12.2	64	144	384

Table 6.4.7: Performance requirements in multipath Case 2 channel.

Test Number	$\frac{\hat{I}_{or}}{I_{oc}}$ [dB]	BLER
1		10 ⁻²
2		10 ⁻¹
		10 ⁻²
3		10 ⁻¹
		10 ⁻²
4		10 ⁻¹
		10 ⁻²

6.4.3.3 Multipath fading Case 3

The performance requirement of DCH in multipath fading Case 3 is determined by the maximum Block Error Rate (BLER) allowed when the receiver input signal is at a specified \hat{I}_{or}/I_{oc} limit. The BLER is calculated for each of the measurement channels supported by the base station.

6.4.3.3.1 Minimum requirement

For the parameters specified in Table 6.4.8 the BLER should not exceed the piece-wise linear BLER curve specified in Table 6.4.9.

Table 6.4.8: Parameters in multipath Case 3 channel

Parameters	Unit	Test 1	Test 2	Test 3	Test 4
Number of DPCH _o		4	1	1	0
Spread factor of DPCH _o		8	8	8	-
$\frac{DPCH_o - E_c}{I_{or}}$	DB	-7	-7	-7	0
I _{oc}	dBm/1.28 MHz	-91			
Information Data Rate	Kbps	12.2	64	144	384

Table 6.4.9: Performance requirements in multipath Case 3 channel.

Test Number	$\frac{\hat{I}_{or}}{I_{oc}}$ [dB]	BLER
1		10^{-2}
2		10^{-1}
		10^{-2}
		10^{-3}
3		10^{-1}
		10^{-2}
		10^{-3}
4		10^{-1}
		10^{-2}
		10^{-3}

[Explanation difference:]

The different performance requirement is result from different propagation condition (Annex 6.B), different service mapping (Annex 6.A), different simulation assumption and different chip rate with 3.84Mcps chip rate TDD.

Annex 6.A (normative): Measurement Channels

6.A.1: General

6.A.2: Reference Measurement Channel;

6.A.2.1 UL reference measurement channel (12.2 kbps)

Parameter	
Information data rate	12.2 kbps
RU's allocated	1TS (1*SF8) = 2RU/5ms
Midamble	144
Interleaving	20 ms
Power control (TPC)	4 Bit/user/10ms
TFCI	16 Bit/user/10ms
Synchronisation Shift (SS)	4 Bit/user/10ms
Inband signalling DCCH	2 kbps
Puncturing level at Code rate 1/3: DCH / DCCH	33% / 33%

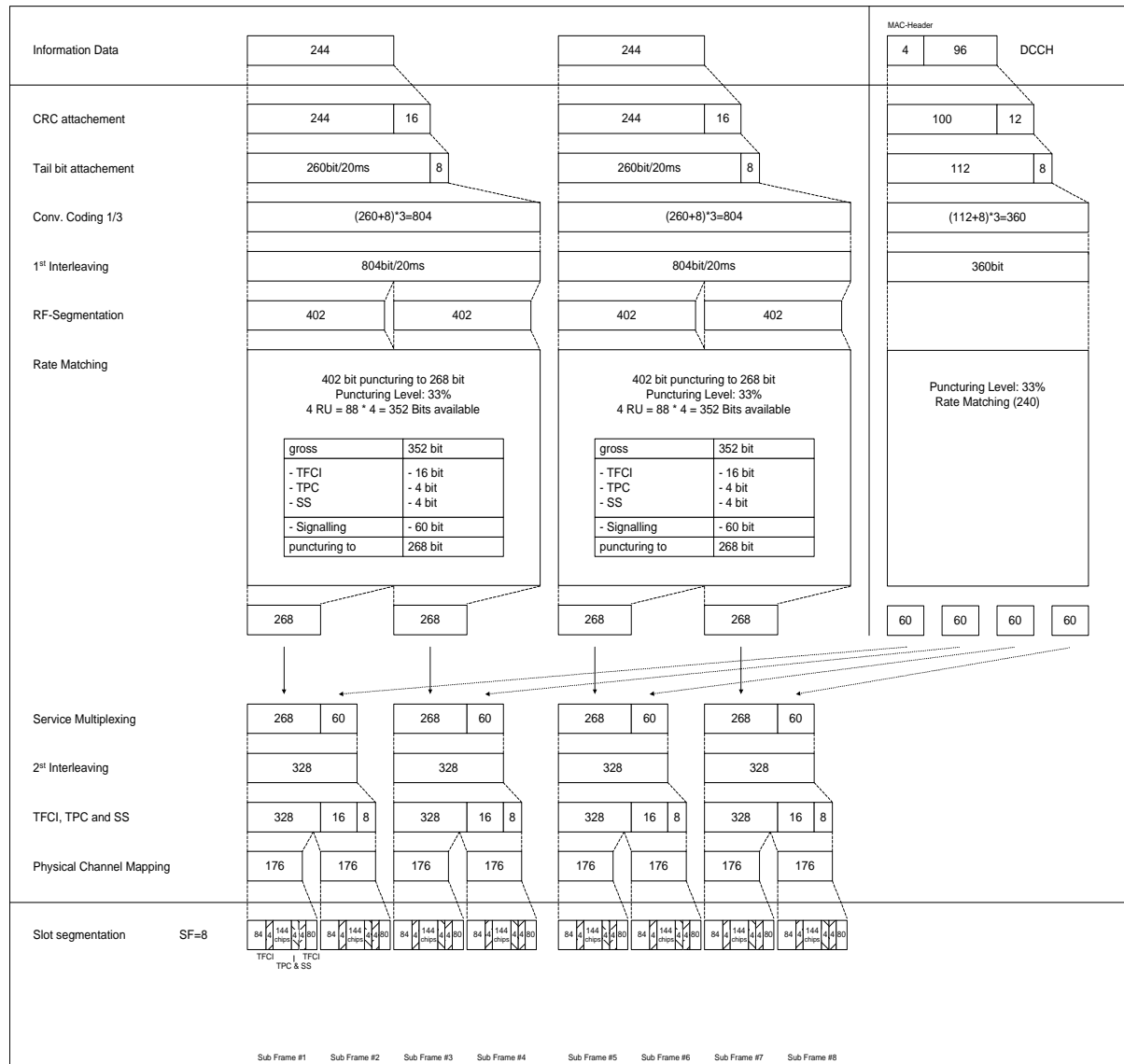

6.A.2.2 UL reference measurement channel (64 kbps)

Parameter	
Information data rate	64 kbps
RU's allocated	1TS (1*SF2) = 8RU/5ms
Midamble	144
Interleaving	20 ms
Power control (TPC)	4 Bit/user/10ms
TFCI	16 Bit/user/10ms
Synchronisation Shift (SS)	4 Bit/user/10ms
Inband signalling DCCH	2 kbps
Puncturing level at Code rate: 1/3 DCH / 1/2 DCCH	32% / 0

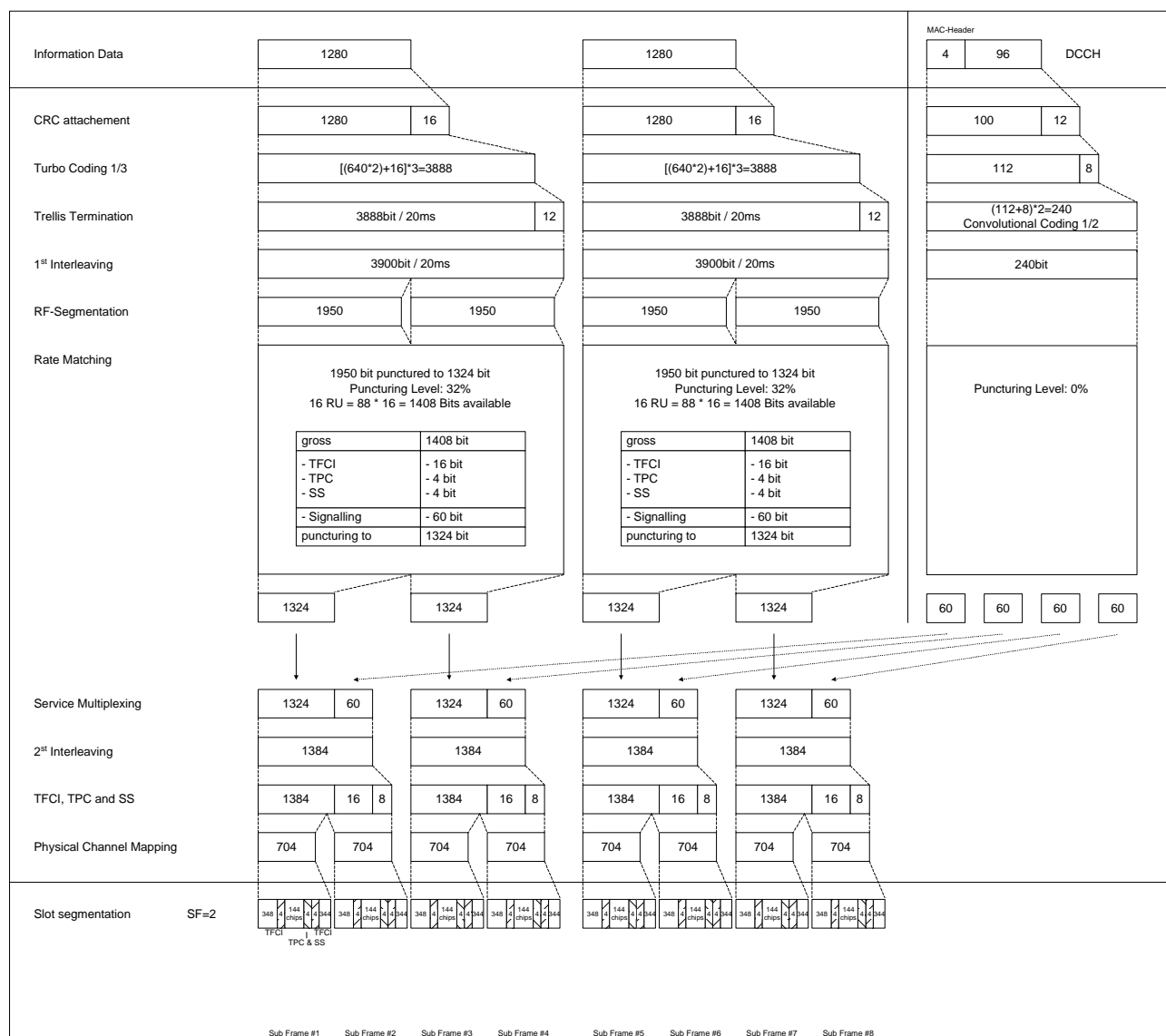

6.A.2.3 UL reference measurement channel (144 kbps)

Parameter	
Information data rate	144 kbps
RU's allocated	2TS (1*SF2) = 16RU/5ms
Midamble	144
Interleaving	20 ms

Power control (TPC)	8 Bit/user/10ms
TFCI	32 Bit/user/10ms
Synchronisation Shift (SS)	8 Bit/user/10ms
Inband signalling DCCH	2 kbps
Puncturing level at Code rate: 1/3 DCH / 1/2 DCCH	38% / 7%

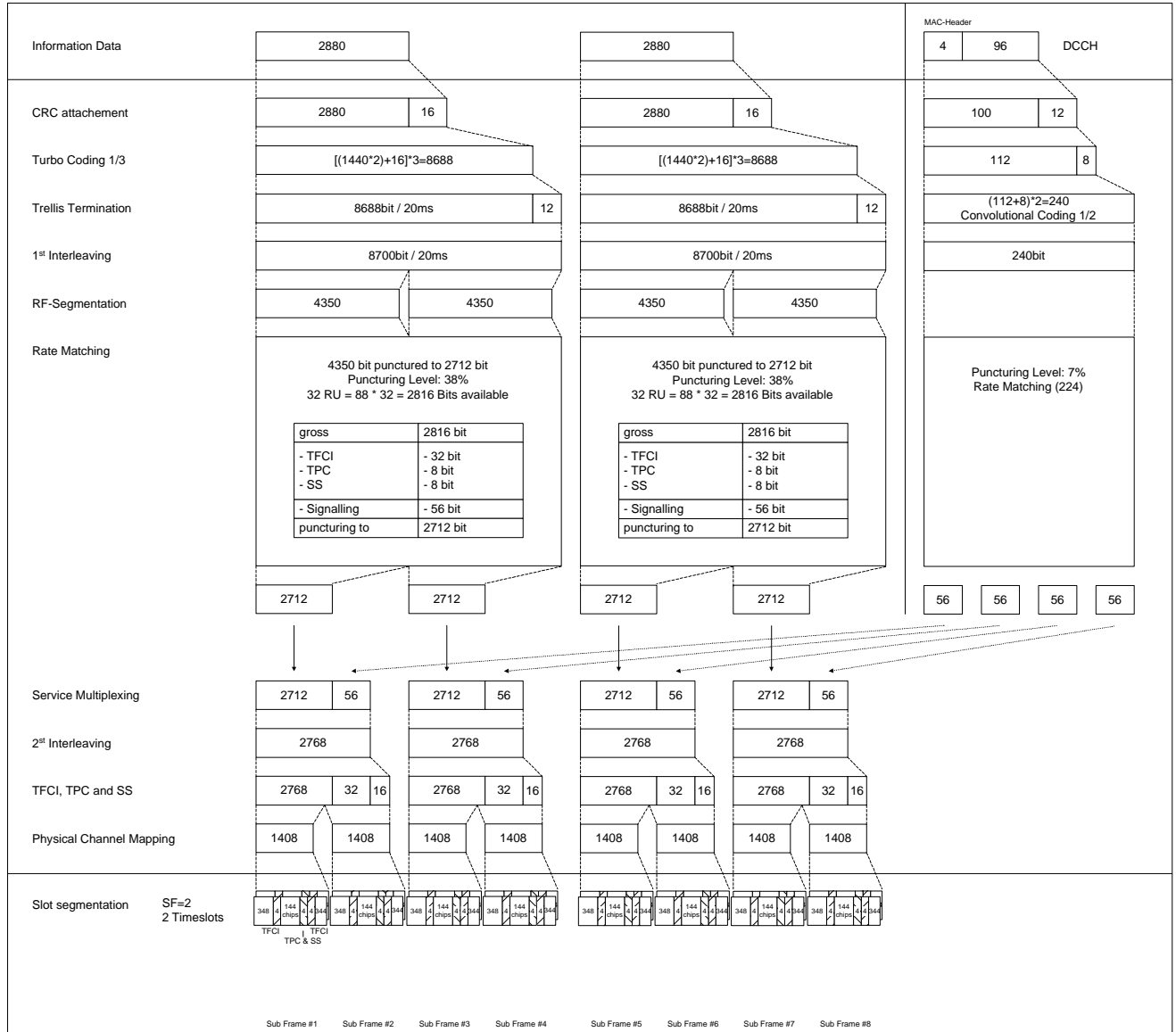

6.A.2.4 UL reference measurement channel (384 kbps)

Parameter	
Information data rate	384 kbps
RU's allocated	4TS (1*SF2 + 1*SF8) = 40RU/5ms
Midamble	144
Interleaving	20 ms
Power control (TPC)	16 Bit/user/10ms
TFCI	64 Bit/user/10ms
Synchronisation Shift (SS)	16 Bit/user/10ms
Inband signalling DCCH	2 kbps
Puncturing level at Code rate: 1/3 DCH / 1/2 DCCH	41% / 12%

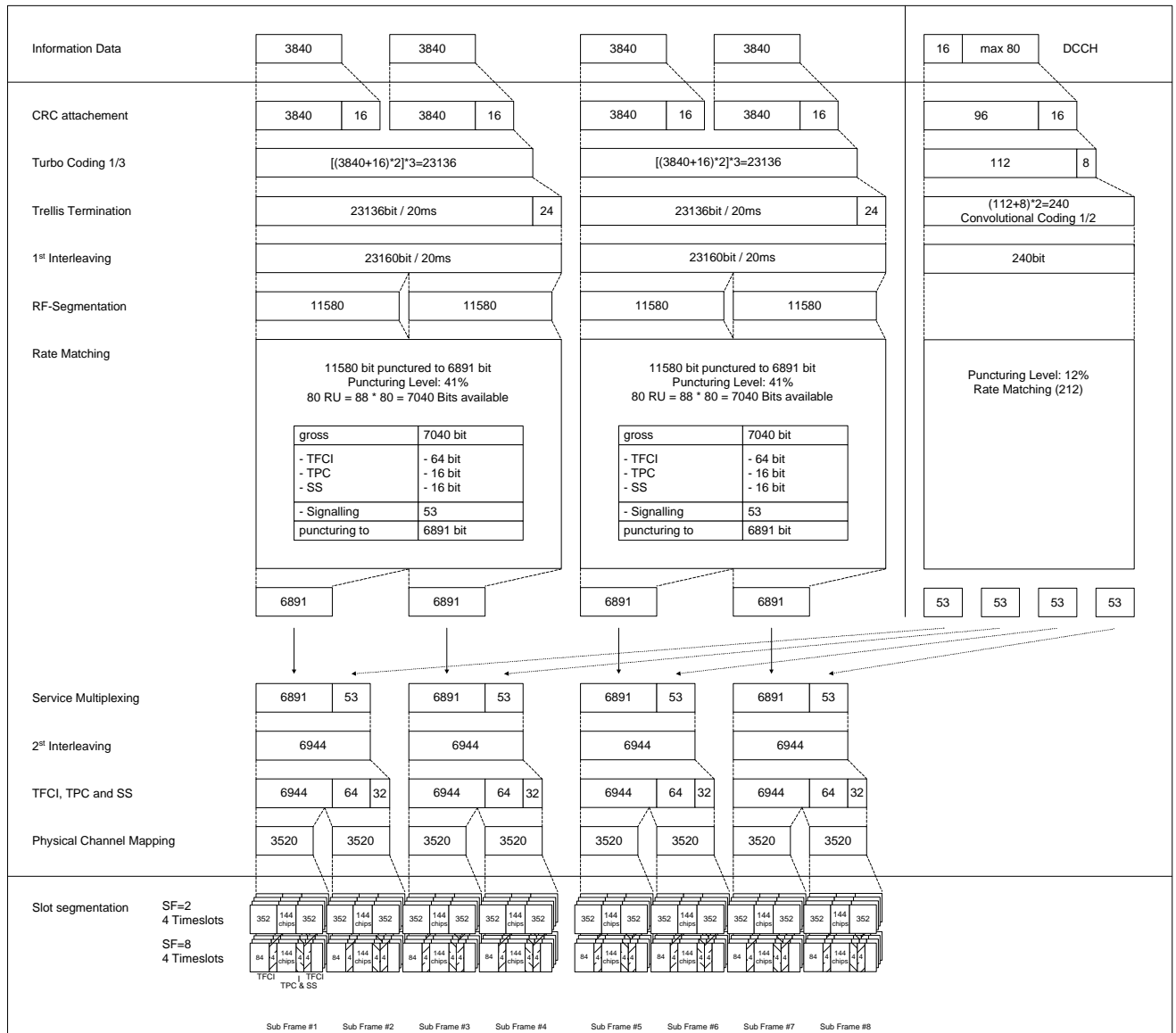

[Explanation difference:]

For the 1.28Mcps chip rate TDD option, one frame (10ms) consists of two sub-frames(5ms), and one

Sub-frame consists of 7 timeslots. The structure of timeslot in 1.28Mcps chip rate TDD (shown inTR25.928) is different from the structure of timeslot in 3.84Mcps TDD. So the service mapping of variance data rate of 1.28Mcps chip rate TDD option is different from that of 3.84Mcps chip rate TDD option.

Annex 6.B (normative): Propagation conditions

6.B.1 Static Propagation conditions

The propagation for the static performance measurement is an Additive White Gaussian Noise (AWGN) environment. No fading and multi-path exist for the propagation model.

6.B.2 multi-path fading Propagation conditions

Table 1 shows propagation conditions that are used for the performance measurements in multi-path fading environment. All taps have classical Doppler spectrum.

Table 2: Propagation Conditions for Multi-Path Fading Environments

Case 1, speed 3km/h		Case 2, speed 3km/h		Case 3, speed 120km/h	
Relative Delay [ns]	Average Power [dB]	Relative Delay [ns]	Average Power [dB]	Relative Delay [ns]	Average Power [dB]
0	0	0	0	0	0
2928	-10	2928	0	781	-3
		12000	0	1563	-6
				2344	-9

[Rationale]:

The channel estimation can only resolve paths with are separated by at least one chip in delay. Otherwise the paths fall into the same tap. Even though this happens in realistic environments, it is not useful to base the propagation models for the performance requirements on a scenario with a delay spread of less than 1 chip, because the baseband is not tested in this case. Therefore, it is proposed to keep the same delay for the path in units of chips for the 1.28Mcps chip rate TDD-mode as for the 3.84Mcps chip rate TDD-mode. The tap delays in units of time are changed accordingly to take into account the difference in the chip rate. Due to the request to have the same maximum delay spread for 1.28Mcps chip rate TDD as for 3.84Mcps chip rate TDD, the delay spread of tap 3rd for the case 2 propagation conditions is set to 12 ms.:

7 Base Station EMC

7.1 Test conditions

7.1.1 General

Common with 3,84Mcps Chip rate TDD option.

7.1.2 Arrangements for establishing a communication link

Common with 3,84Mcps Chip rate TDD option.

7.1.3 Narrow band responses on receivers

For 1.28Mcps chip rate TDD option, responses on receivers or duplex transceivers occurring during the test at discrete frequencies which are narrow band responses (spurious responses), are identified by the following method:

if during an immunity test the quantity being monitored goes outside the specified tolerances, it is necessary to establish whether the deviation is due to a narrow band response or to a wide band (EMC) phenomenon. Therefore, the test shall be repeated with the unwanted signal frequency increased, and then decreased by 3.2MHz;

if the deviation disappears in either or both of the above 3.2 MHz offset cases, then the response is considered as a narrow band response;

if the deviation does not disappear, this may be due to the fact that the offset has made the frequency of the unwanted signal correspond to the frequency of another narrow band response. Under these circumstances the procedure is repeated with the increase and decrease of the frequency of the unwanted signal set to 4MHz;

if the deviation does not disappear with the increased and/or decreased frequency, the phenomenon is considered wide band and therefore an EMC problem and the equipment fails the test.

Narrow band responses are disregarded.

7.2 Performance assessment

7.2.1 General

Common with 3,84Mcps Chip rate TDD option.

7.2.2 Ancillary equipment

Common with 3,84Mcps Chip rate TDD option.

7.3 Performance Criteria

7.3.1 Performance criteria A for continuous phenomena for BS

Common with 3,84Mcps Chip rate TDD option.

7.3.2 Performance criteria B for transient phenomena for BS

Common with 3,84Mcps Chip rate TDD option.

7.3.3 Performance criteria C for BS

Common with 3,84Mcps Chip rate TDD option.

7.3.4 Performance criteria A for continuous phenomena for Ancillary equipment

Common with 3,84Mcps Chip rate TDD option.

7.3.5 Performance criteria B for transient phenomena for Ancillary equipment

Common with 3,84Mcps Chip rate TDD option.

7.3.6 Performance criteria C for Ancillary equipment

Common with 3,84Mcps Chip rate TDD option.

7.4 Applicability overview

7.4.1 Emission

Common with 3,84Mcps Chip rate TDD option.

7.4.2 Immunity

Common with 3,84Mcps Chip rate TDD option.

Annex 7.A (normative): Methods of measurement

7.A.1: Emission

7.A.1.1 Methods of measurement and limits for EMC emissions

Common with 3,84Mcps Chip rate TDD option.

7.A.1.2 Test configurations

Common with 3,84Mcps Chip rate TDD option.

7.A.1.3 Radiated spurious emission from Base station and ancillary equipment

7.A.1.3.1 Radiated spurious emission, Base stations

7.A.1.3.1.1 Definition

Common with 3,84Mcps Chip rate TDD option.

7.A.1.3.1.2 Test method

- a) Common with 3,84Mcps TDD option.
- b) The BS shall transmit with maximum power declared by the manufacturer with all transmitters active. Set the base station to transmit a signal as stated in table 8.3.2.4.1.1 of TR25.945.
- c) The received power shall be measured over the frequency range 30 MHz to 12.75 GHz, excluding 4MHz below the first carrier frequency to 4 MHz above the last carrier frequency used. The measurement bandwidth shall be 100 kHz between 30 MHz and 1 GHz and 1 MHz above 1 GHz as given in ITU-R SM.329-7 [1]. The video bandwidth shall be approximately three times the resolution bandwidth. If this video bandwidth is not available on the measuring receiver, it shall be the maximum available and at least 1 MHz. At each frequency at which a component is detected, the maximum effective radiated power of that component shall be determined, as described in step a.

[Explanation difference:]

To identify responses on receivers or duplex transceivers occurring during the test at discrete frequencies which are narrow band responses, the test shall be repeated with the unwanted signal frequency increased, and then decreased by several bandwidths.

Due to the different bandwidth of the low chip rate TDD option from that of the high chip rate TDD option, the frequency increased and/or decreased is changed from 10MHz to 3.2MHz, from 12.5MHz to 4MHz.

7.A.1.3.1.3 Limits

Common with 3,84Mcps Chip rate TDD option.

7.A.1.3.2 Radiated spurious emission, Ancillary equipment

Common with 3,84Mcps Chip rate TDD option.

7.A.1.4 Conducted emission DC power input/output port

Common with 3,84Mcps Chip rate TDD option.

7.A.1.5 Conducted emissions, AC mains power input/output port

Common with 3,84Mcps Chip rate TDD option.

7.A.1.6 Harmonic Current emissions (AC mains input port)

Common with 3,84Mcps Chip rate TDD option.

7.A.1.7 Voltage fluctuations and flicker (AC mains input port)

Common with 3,84Mcps Chip rate TDD option.

7.A.2: Immunity

Common with 3,84Mcps Chip rate TDD option.

8 BS conformance testing

8.1 Frequency bands and channel arrangement

8.1.1 General

The information presented in this section is based on a chip rate of 1,28Mcps.

8.1.2 Frequency bands

Common with 3,84Mcps TDD option.

8.1.3 TX–RX frequency separation

[Description:]

No TX-RX frequency separation is required as Time Division Duplex (TDD) is employed. Each subframe of 1.28Mcps TDD consists of 7 main timeslots where all main timeslots (at least the first one) before the single switching point are allocated DL and all main timeslots (at least the last one) after the single switching point are allocated UL.

[Explanation of difference:]

The frame structure for 3.84Mcps TDD and 1.28Mcps TDD is different. For 3.84 Mcps TDD, each TDMA frame consists of 15 timeslots where each timeslot can be allocated to either transmit or receive.

8.1.4 Channel arrangement

8.1.4.1 Channel spacing

8.1.4.1.1 Background

The roll filter factor is would be 0.22, then we select the nominal bandwidth as 1.6MHz;
Considering the easy co-existence with Wide-band TDD mode, for its 3 times bandwidth would be 4.8, less than the nominal bandwidth of wide band UTRA TDD;
It is just nominal for 1.6MHz, and it is also flexible to adjust the channel raster step 200kHz to narrow as 1.4MHz for strict requirement situations if needed;
Considering the easy to implementation, for too narrow band of the bandwidth would be very difficult to implementation.

8.1.4.1.2 Channel spacing

The channel spacing for 1.28Mcps chip rate option is 1.6MHz.

8.1.4.2 Channel raster

Common with 3,84Mcps TDD option.

8.1.4.3 Channel number

Common with 3,84Mcps TDD option.

8.2 General test conditions and declarations

8.2.1 Base station classes

Common with 3,84Mcps TDD option.

8.2.2 Output power and determination of power class

Common with 3,84Mcps TDD option.

8.2.3 Specified frequency range

Common with 3,84Mcps TDD option.

8.2.4 Spectrum emission mask

Common with 3,84Mcps TDD option.

8.2.5 Adjacent Channel Leakage power Ratio (ACLR)

Common with 3,84Mcps TDD option.

8.2.6 Tx spurious emissions

8.2.6.1 Category of spurious emissions limit

Common with 3,84Mcps TDD option.

8.2.6.2 Co-existence with GSM

Common with 3,84Mcps TDD option.

8.2.6.3 Co-existence with DCS 1800

Common with 3,84Mcps TDD option.

8.2.6.4 Co-existence with UTRA FDD

Common with 3,84Mcps TDD option.

8.2.7 Blocking characteristics

Common with 3,84Mcps TDD option.

8.2.8 Test environments

Common with 3,84Mcps TDD option.

8.2.9 Interpretation of measurement results

Common with 3,84Mcps TDD option.

8.2.10 Selection of configurations for testing

Common with 3,84Mcps TDD option.

8.2.11 BS Configurations

Common with 3,84Mcps TDD option.

8.2.12 Overview of the conformance test requirements

Common with 3,84Mcps TDD option.

8.2.13 Format and interpretation of tests

Common with 3,84Mcps TDD option.

8.3 Transmitter characteristics

8.3.1 General

Common with 3,84Mcps TDD option.

8.3.2 Maximum output power

8.3.2.1 Definition and applicability

Common with 3,84Mcps TDD option.

8.3.2.2 Conformance requirements

Common with 3,84Mcps TDD option.

8.3.2.3 Test purpose

Common with 3,84Mcps TDD option.

8.3.2.4 Method of test

8.3.2.4.1 Initial conditions

- (1) Common with the 3.84Mcps chip rate
- (2) Common with the 3.84Mcps chip rate
- (3) Common with the 3.84Mcps chip rate
- (4) For 1.28Mcps chip rate TDD option, set the parameters of the transmitted signal according to the following table.

Table 8.3.2-1: Parameters of the transmitted signal for maximum output power test for 1.28Mcps chip rate TDD option

Parameter	Value/description
TDD Duty Cycle	TS i ; $i = 0, 1, 2, 3, 4, 5, 6$: transmit, if i is 0,4,5,6; receive, if i is 1,2,3.
BS output power setting	PRAT
Number of DPCH in each active TS	8
Power of each DPCH	1/8 of Base Station output power
Data content of DPCH	real life (sufficient irregular)

8.3.2.4.2 Procedure

- (1) Measure thermal power over the 848 active chips of a transmit time slot (this excludes the guard periods), and with a measurement bandwidth of at least 1.6 MHz.
- (2) Average over TBD time slots.
- (3) Run steps (1) and (2) for RF channels Low / Mid / High.

8.3.2.5 Test requirements

Common with 3,84Mcps TDD option.

[Explanation difference:]

For the 1.28Mcps chip rate TDD option, one frame(10ms) consists of two subframes(5ms), and one subframe consists of 7 timeslots, the structure of the subframe is shown in section 7.2.1 of TR 25.928. So the number of timeslot i should be 0, 1,...,6. In addition, for the 1.28Mcps chip rate TDD option, the DL reference measurement channel for 144kbits/s need two timeslots, each consists of 8 DPCH(SF=16).So the number of DPCH in each active TS should be 8.

For the 1.28Mcps chip rate TDD option, each TS consists of 864 chips, but 16 chips is for Guard Period, so the measuring thermal power should over 848 active chips.

8.3.3 Frequency stability

8.3.3.1 Definition and applicability

Common with 3,84Mcps TDD option.

8.3.3.2 Conformance requirement

Common with 3,84Mcps TDD option.

8.3.3.3 Test purpose

Common with 3,84Mcps TDD option.

8.3.3.4 Method of test

8.3.3.4.1 Initial conditions

- (1) Common with the 3.84Mcps chip rate
- (2) Common with the 3.84Mcps chip rate
- (3) Common with the 3.84Mcps chip rate
- (4) For 1.28Mcps chip rate TDD option, set the parameters of the transmitted signal according to the following table.

Table 8.3.3-1: Parameters of the transmitted signal for Frequency stability test for 1.28Mcps chip rate TDD option

Parameter	Value/description
TDD Duty Cycle	TS i ; $i = 0, 1, 2, \dots, 6$: transmit, if i is 0, 4,5,6; receive, if i is 1,2,3.
Number of DPCH in each active TS	1
BS output power setting	PRAT
Data content of DPCH	real life (sufficient irregular)

8.3.3.4.2 Procedure

- (1) Common with 3.84Mcps chip rate TDD option.
- (2) Common with 3.84Mcps chip rate TDD option.
- (3) Common with 3.84Mcps chip rate TDD option.

8.3.3.5 Test requirement

Common with 3,84Mcps TDD option.

[Explanation difference:]

For the 1.28Mcps chip rate TDD option, one frame(10ms) consists of two subframes(5ms), and one subframe consists of 7 timeslots, (the structure of the subframe is shown in section 7.2.1 of 3GPP TR 25.928), so the number of timeslot i should be 0, 1, ..., 6.

The frequency stability is a characteristic of the local oscillator and will not change, if the number of DPCH is varied. In these cases, it is felt that the use of only 1 DPCH will make the measurement easier and, at least for some parameters, more exact. Therefore, it is proposed to specify the test for frequency stability with 1 DPCH only also in the case of 1.28 Mcps TDD option.

8.3.4 Output power dynamics

8.3.4.1 Inner loop power control

Common with 3,84Mcps TDD option.

8.3.4.2 Power control steps

8.3.4.2.1 Definition and applicability

Common with 3,84Mcps TDD option.

8.3.4.2.2 Conformance requirements

Common with 3,84Mcps TDD option.

8.3.4.2.3 Test purpose

Common with 3,84Mcps TDD option.

8.3.4.2.4 Method of test

8.3.4.2.4.1 Initial conditions

- (1) Common with the 3.84Mcps chip rate
- (2) Common with the 3.84Mcps chip rate
- (3) For 1.28Mcps chip rate TDD option, set the initial parameters of the transmitted signal according to the following table.
- (4) Common with the 3.84Mcps chip rate
- (5) Common with the 3.84Mcps chip rate

Table 8.3.4-1: Parameters of the transmitted signal for Power control step test for 1.28Mcps chip rate TDD option

Parameter	Value/description
TDD Duty Cycle	TS i ; $i = 0, 1, 2, \dots, 6$: transmit, if i is 0, 4,5,6; receive, if i is 1,2,3.
Number of DPCH in each active TS	1
DPCH power	Minimum
Data content of DPCH	real life (sufficient irregular)

8.3.4.2.4.2 Procedure

- (1) Common with 3.84Mcps chip rate TDD option.
- (2) Set the BS tester to produce a sequence of TPC commands related to the active DPCH. This sequence shall be transmitted to the BS within the time slots TS $i=1,2,3$, and shall consist of a series of TPC commands with content "Increase Tx power", followed by a series of TPC commands with content "Decrease Tx power". Each of these series should be sufficiently long so that the transmit output power of the active DPCH is controlled to reach its maximum and its minimum, respectively.
- (3) Measure the power of the active DPCH over the 848 active chips of each time slot TS $i=0,4,5,6$ (-this excludes the guard period), and with a measurement filter that has a RRC filter response with a roll off $\alpha = 0,22$ and a bandwidth equal to the chip rate. The power is determined by calculating the RMS value of the signal samples at the measurement filter output taken at the decision points.
- (4) Common with 3.84Mcps chip rate TDD option.
- (5) Common with 3.84Mcps chip rate TDD option.

8.3.4.2.5 Test requirements

Common with 3,84Mcps TDD option.

[Explanation difference:]

For the 1.28Mcps chip rate TDD option, one frame(10ms) consists of two subframes(5ms), and one subframe consists of 7 timeslots, (the Structure of subframe is shown in section7.2.1 of 3GPP TR 25.928), so the number of timeslot i should be 0, 1,...,6.

For the 1.28Mcps chip rate TDD option, each TS consists of 864 chips, but 16 chips is for Guard Period,so the measuring power should over 848 active chips.

8.3.4.3 Power control dynamic range

8.3.4.3.1 Definition and applicability

Common with 3,84Mcps TDD option.

8.3.4.3.2 Conformance requirements

Common with 3,84Mcps TDD option.

8.3.4.3.3 Test purpose

Common with 3,84Mcps TDD option.

8.3.4.3.4 Method of test

8.3.4.3.4.1 Initial conditions

- (1) Common with the 3.84Mcps chip rate
- (2) For 1.28Mcps chip rate TDD option, set the initial parameters of the transmitted signal according to the following table.
- (3) Common with the 3.84Mcps chip rate
- (4) Common with the 3.84Mcps chip rate

Table 8.3.4-2: Parameters of the transmitted signal for Power control dynamic range test for 1.28Mcps chip rate TDD option

Parameter	Value/description
TDD Duty Cycle	TS i ; $i = 0, 1, 2, \dots, 6$: transmit, if i is 0, 4,5,6; receive, if i is 1,2,3.
Number of DPCH in each active TS	1
Data content of DPCH	real life (sufficient irregular)

8.3.4.3.4.2 Procedure

- (1) Common with 3.84Mcps chip rate TDD option.
- (2) Set the BS tester to produce a sequence of TPC commands related to the active DPCH, with content "Increase Tx power". This sequence shall be sufficiently long so that the transmit output power of the active DPCH is controlled to reach its maximum, and shall be transmitted to the BS within the TS $i=1,2,3$ time slots.
- (3) Measure the power of the active DPCH over the 848 active chips of each time slot TS $i=0,4,5,6$ (this excludes the guard period), and with a measurement filter that has a RRC filter response with a roll off $\alpha = 0,22$ and a bandwidth equal to the chip rate. The power is determined by calculating the RMS value of the signal samples at the measurement filter output taken at the decision points.
- (4) Common with 3.84Mcps chip rate TDD option.
- (5) Set the BS tester to produce a sequence of TPC commands related to the active DPCH, with content "Decrease Tx power". This sequence shall be sufficiently long so that the transmit output power of the active DPCH is controlled to reach its minimum, and shall be transmitted to the BS within the time slots TS $i=1,2,3$.
- (6) Measure the power of the active DPCH over the 848 active chips of each time slot TS $i=0,4,5,6$ (this excludes the guard period), and with a measurement filter that has a RRC filter response with a roll off $\alpha = 0,22$ and a bandwidth equal to the chip rate. The power is determined by calculating the RMS value of the signal samples at the measurement filter output taken at the decision points.
- (7) Common with 3.84Mcps chip rate TDD option.
- (8) Common with 3.84Mcps chip rate TDD option.
- (9) Common with 3.84Mcps chip rate TDD option.

8.3.4.3.5 Test requirements

Common with 3,84Mcps TDD option.

[Explanation difference:]

For the 1.28Mcps chip rate TDD option, one frame(10ms) consists of two subframes(5ms), and one subframe consists of 7 timeslots, (the structure of the subframe is shown in section 7.2.1 of 3GPP TR 25.928), so the number of timeslot i should be 0, 1, ..., 6.

For the 1.28Mcps chip rate TDD option, each TS consists of 864 chips, but 16 chips is for Guard Period, so the measuring power should over 848 active chips.

8.3.4.4 Minimum transmit power

8.3.4.4.1 Definition and applicability

Common with 3,84Mcps TDD option.

8.3.4.4.2 Conformance requirements

Common with 3,84Mcps TDD option.

8.3.4.4.3 Test purpose

Common with 3,84Mcps TDD option.

8.3.4.4.4 Method of test

8.3.4.4.4.1 Initial conditions

- (1) Common with the 3.84Mcps chip rate
- (2) For 1.28Mcps chip rate TDD option, set the parameters of the transmitted signal according to the following table.
- (3) Common with the 3.84Mcps chip rate
- (4) Common with the 3.84Mcps chip rate

Table 8.3.4-3: Parameters of the transmitted signal for Minimum transmit power test for 1.28Mcps chip rate TDD option

Parameter	Value/description
TDD Duty Cycle	TS i ; $i = 0, 1, 2, 3, 4, 5, 6$: transmit, if i is 0,4,5,6; receive, if i is 1,2,3.
BS output power setting	PRAT
Number of DPCH in each active TS	8
Power of each DPCH	1/8 of Base Station output power
Data content of DPCH	real life (sufficient irregular)

8.3.4.4.4.2 Procedure

- (1) Common with 3.84Mcps chip rate TDD option.
- (2) Set the BS tester to produce a sequence of TPC commands related to all active DPCH, with content "Decrease Tx power". This sequence shall be sufficiently long so that the transmit output power of all active DPCH is controlled to reach its minimum, and shall be transmitted to the BS within the time slots TS $i=1,2,3$ (receive time slots of the BS).
- (3) Measure the power of the BS output signal over the 848 active chips of each time slot TS $i=0,4,5,6$ (this excludes the guard period), and with a measurement filter that has a RRC filter response with a roll off $\alpha = 0,22$ and a bandwidth equal to the chip rate. The power is determined by calculating the RMS value of the signal samples at the measurement filter output taken at the decision points.
- (4) Average over TBD time slots.
- (5) Common with 3.84Mcps chip rate TDD option.

8.3.4.4.5 Test requirements

Common with 3,84Mcps TDD option.

[Explanation difference:]

For the 1.28Mcps chip rate TDD option, one frame(10ms) consists of two subframes(5ms), and one subframe consists of 7 timeslots, the structure of subframe is shown in Section 7.2.1 of TR 25.928. So the number of timeslot i should be 0, 1, ..., 6. In addition, for the 1.28Mcps chip rate TDD option, the DL reference measurement channel for 144kbts/s need two timeslots, each consists of 8 DPCH(SF=16). So the number of DPCH in each active TS should be 8.

For the 1.28Mcps chip rate TDD option, each TS consists of 864 chips, but 16 chips is for Guard Period, so the measuring thermal power should over 848 active chips.

8.3.4.5 Primary CCPCH power

8.3.4.5.1 Definition and applicability

Common with 3,84Mcps TDD option.

8.3.4.5.2 Conformance requirement

Common with 3,84Mcps TDD option.

8.3.4.5.3 Test purpose

Common with 3,84Mcps TDD option.

8.3.4.5.4 Method of test

8.3.4.5.4.1 Initial conditions

- (1) Common with the 3.84Mcps chip rate
- (2) For 1.28Mcps chip rate TDD option, set the parameters of the transmitted signal according to the following table.

Table 8.3.4-4 : Parameters of the BS transmitted signal for Primary CCPCH power testing for 1.28Mcps chip rate TDD option

Parameter	Value/description
TDD Duty Cycle	TS i ; $i = 0, 1, 2, \dots, 6$: transmit, if i is 0,4,5,6; receive, if i is 1,2,3.
Time slots carrying PCCPCH	TS 0
BS output power setting	PRAT
Relative power of PCCPCH	1/2 of BS output power
Data content of DPCH	real life (sufficient irregular)

8.3.4.5.4.2 Procedure

- (1) Measure the PCCPCH power in TS 0 by applying the global in-channel Tx test method described in Annex C.
- (2) Reduce the base station output power by 2 dB, 5 dB and 13 dB, without changing the

relative powers of the PCCPCH, and repeat step (1) for each output power setting.

8.3.4.5.5 Test requirement

Common with 3,84Mcps TDD option.

[Explanation difference:]

For the 1.28Mcps chip rate TDD option, one frame(10ms) consists of two subframes(5ms), and one subframe consists of 7 timeslots, the structure of subframe is shown in section 7.2.1 of TR 25.928. So the number of timeslot i should be 0, 1, ..., 6.

In 1,28Mcps TDD option, likely scenario is that TS 0 is only used for broadcast, so no DPCH in TS 0.

8.3.5 Transmit OFF power

8.3.5.1 Definition and applicability

Common with 3,84Mcps TDD option.

8.3.5.2 Conformance requirements

Common with 3,84Mcps TDD option.

8.3.5.3 Test purpose

Common with 3,84Mcps TDD option.

8.3.5.4 Method of test

8.3.5.4.1 Initial conditions

Common with the 3.84Mcps chip rate

(2) For 1.28Mcps chip rate TDD option, set the parameters of the transmitted signal according to the following table.

Table 8.3.5-1: Parameters of the transmitted signal for transmit off power test for 1.28Mcps chip rate TDD option

Parameter	Value/description
TDD Duty Cycle	TS i ; $i = 0, 1, 2, 3, 4, 5, 6$: transmit, if i is 0,4,5,6; receive, if i is 1,2,3.
BS output power setting	PRAT
Number of DPCH in each active TS	8
Power of each DPCH	1/8 of Base Station output power
Data content of DPCH	real life (sufficient irregular)

8.3.5.4.2 Procedure

(1) Measure the power of the BS output signal chipwise (i.e. averaged over time intervals of one chip duration) over the transmit off power period starting 20 chips before the start of the receive time slot TS $i = 3$, and ending 16 chips before the next transmit time slot TS $i=4$ starts, and with a measurement filter that has a RRC filter response with a roll off $\alpha = 0,22$ and a bandwidth equal to the chip rate. If the power measuring equipment is based on signal sampling, the sampling theorem shall be met. In this case, the power is determined by calculating the RMS value of the signal samples taken at the measurement filter output over one chip duration.

(2) Run steps (1) and (2) for RF channels Low / Mid / High.

8.3.5.5 Test requirements

Common with 3,84Mcps TDD option.

[Explanation difference:]

For the 1.28Mcps chip rate TDD option, one frame(10ms) consists of two subframes(5ms), and one subframe consists of 7 timeslots, (the subframe is shown in section 7.2.1 of 3GPP TR 25.928), so the number of timeslot i should be 0, 1,...,6. In addition, for the 1.28Mcps chip rate TDD option, the DL reference measurement channel for 144kbps/s need two timeslots, each consists of 8 DPCH(SF=16).So the number of DPCH in each active TS should be 8.

8.3.6 Output RF spectrum emissions

8.3.6.1 Occupied bandwidth

8.3.6.1.1 Definition and applicability

Common with 3,84Mcps TDD option.

8.3.6.1.2 Conformance requirements

The occupied bandwidth shall be less than 1,6 MHz based on a chip rate of 1,28 Mcps.

8.3.6.1.3 Test purpose

Common with 3,84Mcps TDD option.

8.3.6.1.4 Method of test

8.3.6.1.4.1 Initial conditions

(1) Common with the 3.84Mcps chip rate

(2) For 1.28Mcps chip rate TDD option, set the parameters of the transmitted signal according to the

following table.

Table 8.3.6-1: Parameters of the transmitted signal for occupied bandwidth test for 1.28Mcps chip rate TDD option

Parameter	Value/description
TDD Duty Cycle	TS i ; $i = 0, 1, 2, 3, 4, 5, 6$: transmit, if i is 0,4,5,6; receive, if i is 1,2,3.
BS output power setting	PRAT
Number of DPCH in each active TS	8
Power of each DPCH	1/8 of Base Station output power
Data content of DPCH	real life (sufficient irregular)

8.3.6.1.4.2 Procedure

- (1) Measure the power of the transmitted signal with a measurement filter of bandwidth 30 kHz. The characteristic of the filter shall be approximately Gaussian (typical spectrum analyzer filter). The center frequency of the filter shall be stepped in contiguous 30 kHz steps from a minimum frequency, which shall be $(2,4 - 0,015)$ MHz below the assigned channel frequency of the transmitted signal, up to a maximum frequency, which shall be $(2,4 + 0,015)$ MHz above the assigned channel frequency of the transmitted signal. The time duration of each step shall be sufficiently long to capture one active time slot. The measured power shall be recorded for each step.
- (2) Determine the transmitted power within the assigned channel bandwidth by accumulating the recorded power measurements results of all steps with center frequencies from $(0,8 - 0,015)$ MHz below the assigned channel frequency up to $(0,8 + 0,015)$ MHz above the assigned channel frequency.
- (3) Determine the total transmitted power by accumulating the recorded power measurements results of all steps.
- (4) Calculate the ratio
transmitted power within the assigned channel bandwidth acc. to (2) / total transmitted power acc. to (3).

8.3.6.1.5 Test requirements

Common with 3,84Mcps TDD option.

[Explanation difference:]

For the 1.28Mcps chip rate TDD option, one frame(10ms) consists of two subframes(5ms), and one subframe consists of 7 timeslots, the structure of subframe is shown in section 7.2.1 of TR 25.928. So the number of timeslot i should be 0, 1,...,6. In addition, for the 1.28Mcps chip rate TDD option, the DL reference measurement channel for 144kbts/s need two timeslots, each consists of 8 DPCH(SF=16).So the number of DPCH in each active TS should be 8.

8.3.6.2 Out of band emission

8.3.6.2.1 Spectrum emission mask

8.3.6.2.1.1 Definition and applicability

For 1.28Mcps chip rate TDD option, the spectrum emission mask specifies the limit of the transmitter out of band emissions at frequency offsets from the assigned channel frequency of the wanted signal between 0,8 MHz and 4,0 MHz.

8.3.6.2.1.2 Conformance requirements

Emissions shall not exceed the maximum level specified in tables in Section 6.2.6.2.1 of TR 25.945.

8.3.6.2.1.3 Test purpose

The test purpose is to verify that the BS out of band emissions do not result in undue interference to any other system (wideband, narrowband) operating at frequencies close to the assigned channel bandwidth of the wanted signal.

This test is independent of the characteristics of possible victim systems and, therefore, complements the tests on occupied bandwidth in 8.3.6.1 of TR 25.945 (verifying the spectral concentration of the BS Tx emissions) and on ACLR in 8.3.6.2.2 of TR 25.945 (simulating the perception of other receivers).

8.3.6.2.1.4 Method of test

8.3.6.2.1.4.1 Initial conditions

(1) Common with the 3.84Mcps chip rate

(2) For 1.28Mcps chip rate TDD option, set the parameters of the transmitted signal according to the following table.

Table 1: Parameters of the transmitted signal for spectrum emission mask test for 1.28Mcps chip rate TDD option

Parameter	Value/description
TDD Duty Cycle	TS i ; $i = 0, 1, 2, 3, 4, 5, 6$: transmit, if i is 0,4,5,6; receive, if i is 1,2,3.
BS output power setting	PRAT
Number of DPCH in each active TS	8
Power of each DPCH	1/8 of Base Station output power
Data content of DPCH	real life (sufficient irregular)

8.3.6.2.1.4.2 Procedure

Measure the power of the BS spectrum emissions by applying measurement filters with bandwidths as specified in the relevant table in subclause 8.3.6.2.1.2. The characteristic of the filters shall be approximately Gaussian (typical spectrum analyzer filters). The center frequency of the filter shall be stepped in contiguous steps over the frequency bands as given in the tables. The step width shall be equal to the respective measurement bandwidth. The time duration of each step shall be sufficiently long to capture one active time slot.

8.3.6.2.1.5 Test requirements

The spectrum emissions measured according to subclause 8.3.6.2.1.4.2 shall be within the mask defined in the relevant table of subclause 8.3.6.2.1.2.

[Explanation difference:]

For the 1.28Mcps chip rate TDD option, one frame(10ms) consists of two subframes(5ms), and one subframe consists of 7 timeslots, the structure of subframe is shown in section 7.2.1 of TR 25.928. So the number of timeslot i should be 0, 1,...,6. In addition, for the 1.28Mcps chip rate TDD option, the DL reference measurement channel for 144kbits/s need two timeslots, each consists of 8 DPCH(SF=16).So the number of DPCH in each active TS should be 8.

8.3.6.2.2 Adjacent Channel Leakage power Ratio (ACLR)

8.3.6.2.2.1 Definition and applicability

Common with 3,84Mcps TDD option.

8.3.6.2.2.2 Conformance requirements

The ACLR shall be equal to or greater than the limits given in Tables in section 6.2.6.2.2 of TR 25.945.

8.3.6.2.2.3 Test purpose

Common with 3,84Mcps TDD option.

8.3.6.2.2.4 Method of test

8.3.6.2.2.4.1 Initial conditions

(1) Common with the 3.84Mcps chip rate

(2) For 1.28Mcps chip rate TDD option, set the parameters of the transmitted signal according to the following table.

Table 8.3.6-2: Parameters of the transmitted signal for ACLR test for 1.28Mcps chip rate TDD option

Parameter	Value/description
TDD Duty Cycle	TS i ; $i = 0, 1, 2, 3, 4, 5, 6$: transmit, if i is 0,4,5,6; receive, if i is 1,2,3.
BS output power setting	PRAT
Number of DPCH in each active TS	8
Power of each DPCH	1/8 of Base Station output power
Data content of DPCH	real life (sufficient irregular)

8.3.6.2.2.4.2 Procedure

- (1) Measure transmitted power over the 848 active chips of the time slots TS $i=0,4,5,6$ (this excludes the guard period), and with a measurement filter that has a RRC filter response with a roll off $\alpha = 0,22$ and a bandwidth equal to the chip rate. The power is determined by calculating the RMS value of the signal samples at the measurement filter output taken at the decision points. (The global in-channel Tx test described in Annex C may be applied.)
- (2) Average over TBD time slots.
- (3) Measure interference power at the first lower adjacent RF channel (center frequency 1,6 MHz below the assigned channel frequency of the transmitted signal) over the useful part of the burst within the time slots TS $i=0,4,5,6$ (this excludes the guard period), and with a measurement filter that has a RRC filter response with a roll off $\alpha = 0,22$ and a bandwidth equal to the chip rate. The power is determined by calculating the RMS value of the signal samples at the measurement filter output taken with adherence to the sampling theorem.
- (4) Average over TBD time slots.
- (5) Calculate the ACLR by the ratio

$$\text{ACLR} = \text{transmitted power acc. to (2)} / \text{interference power acc. to (4)}.$$
- (6) Repeat steps (3), (4) and (5) for the second lower adjacent RF channel (center frequency 3,2 MHz below the assigned channel frequency of the transmitted signal) and also for the first and second upper adjacent RF channel (center frequency 1,6 MHz and 3,2 MHz above the assigned channel frequency of the transmitted signal, respectively).

8.3.6.2.2.5 Test requirements

The ACLR calculated in step (5) of subclause 8.3.6.2.2.4.2 shall be equal or greater than the limits given in tables in section 6.2.6.2.2 of TR 25.945.

[Explanation difference:]

For the 1.28Mcps chip rate TDD option, one frame(10ms) consists of two subframes(5ms), and one subframe consists of 7 timeslots, (the structure of subframe is shown in TR 25.928), so the number of timeslot i should be 0, 1,...,6. In addition, for the 1.28Mcps chip rate TDD option, the DL reference measurement channel for 144kbits/s need two timeslots,

each consists of 8 DPCH(SF=16).So the number of DPCH in each active TS should be 8. For the 1.28Mcps chip rate TDD option, each TS consists of 864 chips, but 16 chips is for Guard Period, so the measuring thermal power should be over 848 active chips.

8.3.6.3 Spurious emissions

8.3.6.3.1 Definition and applicability

Spurious emissions are emissions which are caused by unwanted transmitter effects such as harmonics emission, parasitic emission, intermodulation products and frequency conversion products, but exclude out of band emissions. This is measured at the base station RF output port. The requirements in this subclause shall apply to base stations intended for general-purpose applications.

8.3.6.3.2 Conformance requirements

The requirements of either subclause 6.2.6.3.1 or subclause 6.2.6.3.2 of TR 25.945 shall apply whatever the type of transmitter considered (single carrier or multi-carrier). It applies for all transmission modes foreseen by the manufacturer.

Either requirement applies at frequencies within the specified frequency ranges which are more than 4 MHz under the first carrier frequency used or more than 4 MHz above the last carrier frequency used.

The power of any spurious emission shall not exceed the maximum level given in Tables in subclause 6.2.6.3 of TR 25.945.

8.3.6.3.3 Test purpose

The test purpose is to verify the ability of the BS to limit the interference caused by unwanted transmitter effects to other systems operating at frequencies which are more than 4 MHz away from of the UTRA band used.

8.3.6.3.4 Method of test

8.3.6.3.4.1 Initial conditions

(1) Common with the 3.84Mcps chip rate

(2) For 1.28Mcps chip rate TDD option, set the parameters of the transmitted signal according to the following table.

Table 8.3.6-3: Parameters of the transmitted signal for spurious emissions for 1.28Mcps chip rate TDD option

Parameter	Value/description
TDD Duty Cycle	TS i ; $i = 0, 1, 2, 3, 4, 5, 6$: transmit, if i is 0,4,5,6; receive, if i is 1,2,3.
BS output power setting	PRAT
Number of DPCH in each active TS	8
Power of each DPCH	1/8 of Base Station output power
Data content of DPCH	real life (sufficient irregular)

8.3.6.3.4.2 Procedure

Measure the power of the spurious emissions by applying measurement filters with bandwidths as specified in the relevant tables of 8.3.6.3.2. The characteristic of the filters shall be approximately Gaussian (typical spectrum analyzer filters). The center frequency of the filter shall be stepped in contiguous steps over the frequency bands as given in the tables. The step width shall be equal to the respective measurement bandwidth. The time duration of each step shall be sufficiently long to capture one active time slot.

8.3.6.3.5 Test requirements

The spurious emissions measured according to subclause 8.3.6.3.4.2 shall not exceed the limits specified in the relevant tables of 8.3.6.3.2.

[Explanation difference:]

For the 1.28Mcps chip rate TDD option, one frame(10ms) consists of two subframes(5ms), and one subframe consists of 7 timeslots, (the subframe is shown in section7.2.1 of 3GPP TR 25.928), so the number of timeslot i should be 0, 1,...,6. In addition, for the 1.28Mcps chip rate TDD option, the DL reference measurement channel for 144kbps/s need two timeslots, each consists of 8 DPCH(SF=16).So the number of DPCH in each active TS should be 8.

8.3.7 Transmit intermodulation

8.3.7.1 Definition and applicability

The transmit intermodulation performance is a measure of the capability of the transmitter to inhibit the generation of signals in its non linear elements caused by presence of the wanted signal and an interfering signal reaching the transmitter via the antenna.

The transmit intermodulation level is the power of the intermodulation products when a CDMA modulated interference signal is injected into the antenna connector at a level of 30 dB lower than that of the subject signal. The frequency of the interference signal shall be $\pm 1,6$ MHz, $\pm 3,2$ MHz and

$\pm 4,8$ MHz offset from the subject signal.

The requirements in this subclause shall apply to base stations intended for general-purpose applications.

8.3.7.2 Conformance requirements

The transmit intermodulation level shall not exceed the out of band or the spurious emission requirements of subclause 8.3.6.2 and 8.3.6.3, respectively.

8.3.7.3 Test purpose

The test purpose is to verify the ability of the BS transmitter to restrict the generation of intermodulation products in its non linear elements caused by presence of the wanted signal and an interfering signal reaching the transmitter via the antenna to below specified levels.

8.3.7.4 Method of test

8.3.7.4.1 Initial conditions

Common with the 3.84Mcps chip rate

(2) For 1.28Mcps chip rate TDD option, set the parameters of the transmitted signal according to the following table.

Table 8.3.7-1: Parameters of the transmitted signal for transmit intermodulation for 1.28Mcps chip rate TDD option

Parameter	Value/description
TDD Duty Cycle	TS i ; $i = 0, 1, 2, 3, 4, 5, 6$: transmit, if i is 0,4,5,6; receive, if i is 1,2,3.
BS output power setting	PRAT
Number of DPCH in each active TS	8
Power of each DPCH	1/8 of Base Station output power
Data content of DPCH	real life (sufficient irregular)

(3) Configure the CDMA signal generator to produce an interference signal with a level of 30 dB lower than that of the BS transmitted signal. The interference signal shall be like-modulated as the BS transmitted signal, and the active time slots of both signals shall be synchronized. The frequency of the interference signal shall be $\pm 1,6$ MHz, $\pm 3,2$ MHz and $\pm 4,8$ MHz offset from the BS transmitted signal.

8.3.7.4.2 Procedure

Apply the test procedures for out of band and spurious emissions as described in 8.3.6.2 and 8.3.6.3, respectively. The frequency band occupied by the interference signal are excluded from the measurements.

8.3.7.5 Test requirements

The conformance requirements for out of band and spurious emissions as specified in 8.3.6.2 and 8.3.6.3 shall be met.

[Explanation difference:]

For the 1.28Mcps chip rate TDD option, one frame(10ms) consists of two subframes(5ms), and one subframe consists of 7 timeslots, (the structure of the subframe is shown in section 7.2.1 of 3GPP TR 25.928), so the number of timeslot i should be 0, 1, ..., 6. In addition, for the 1.28Mcps chip rate TDD option, the DL reference measurement channel for 144kbps/s need two timeslots, each consists of 8 DPCH(SF=16). So the number of DPCH in each active TS should be 8.

Because the bandwidth of 1,28Mcps TDD option is 1,6MHz, the frequency offset of interference signal shall be $\pm 1,6$ MHz, $\pm 3,2$ MHz and $\pm 4,8$ MHz.

8.3.8 Transmit Modulation

8.3.8.1 Modulation accuracy

8.3.8.1.1 Definition and applicability

The modulation accuracy is a measure of the difference between the measured waveform and the theoretical modulated waveform (the error vector). A quantitative measure of the modulation accuracy is the error vector magnitude (EVM) which is defined as the square root of the ratio of the mean error vector power to the mean reference signal power expressed as %. The measurement interval is one timeslot.

The requirements in this subclause shall apply to base stations intended for general-purpose applications.

NOTE: The theoretical modulated waveform shall be calculated on the basis that the transmit pulse shaping filter is a root-raised cosine (RRC) with roll-off $\alpha=0,22$ in the frequency domain. The impulse response of the chip impulse filter $RC_0(t)$ is

$$RC_0(t) = \frac{\sin\left(\pi \frac{t}{T_c}(1-\alpha)\right) + 4\alpha \frac{t}{T_c} \cos\left(\pi \frac{t}{T_c}(1+\alpha)\right)}{\pi \frac{t}{T_c} \left(1 - \left(4\alpha \frac{t}{T_c}\right)^2\right)}$$

Where the roll-off factor $\alpha = 0,22$ and for 1.28Mcps chip rate option the chip

$$\text{duration } T_c = \frac{1}{\text{chiprate}} = 0.78125 \mu\text{s}.$$

8.3.8.1.2 Conformance requirements

Common with 3,84Mcps TDD option.

8.3.8.1.3 Test purpose

Common with 3,84Mcps TDD option.

8.3.8.1.4 Method of test

8.3.8.1.4.1 Initial conditions

(1) Common with the 3.84Mcps chip rate

(2) For 1.28Mcps chip rate TDD option, set the parameters of the transmitted signal according to the following table.

Table 8.3.8-1: Parameters of the transmitted signal for modulation accuracy for 1.28Mcps chip rate TDD option

Parameter	Value/description
TDD Duty Cycle	TS i ; $i = 0, 1, 2, \dots, 6$: Transmit, if i is 0,4,5,6; receive, if i is 1,2,3.
Number of DPCH in each active TS	1
Base station power	maximum, according to manufacturer's declaration
Data content of DPCH	real life (sufficient irregular)

8.3.8.1.4.2 Procedure

Common with 3,84Mcps Chip rate TDD option

8.3.8.1.5 Test requirements

Common with 3,84Mcps TDD option.

[Explanation difference:]

For the 1.28Mcps chip rate TDD option, one frame(10ms) consists of two subframes(5ms), and one subframe consists of 7 timeslots, so the number of timeslot i should be 0, 1,...,6. The structure of subframe is shown in section 7.2.1 of TR 25.928.

8.3.8.2 Peak code domain error

8.3.8.2.1 Definition and applicability

Common with 3,84Mcps TDD option.

8.3.8.2.2 Conformance requirements

Common with 3,84Mcps TDD option.

8.3.8.2.3 Test purpose

Common with 3,84Mcps TDD option.

8.3.8.2.4 Method of test

8.3.8.2.4.1 Initial conditions

(1) Common with the 3.84Mcps chip rate

(2) For 1.28Mcps chip rate TDD option, set the parameters of the transmitted signal according to the following table.

Table 8.3.8-2: Parameters of the transmitted signal for Peak code domain error for 1.28Mcps chip rate TDD option

Parameter	Value/description
TDD Duty Cycle	TS i ; $i = 0, 1, 2, \dots, 6$: transmit, if i is 0,4,5,6; receive, if i is 1,2,3.
BS output power setting	PRAT
Number of DPCH in each active TS	8
Power of each DPCH	1/8 of Base Station output power
Data content of DPCH	real life (sufficient irregular)
Spreading factor	16

8.3.8.2.4.2 Procedure

Common with 3,84Mcps Chip rate TDD option

[Explanation difference:]

For the 1.28Mcps chip rate TDD option, one frame(10ms) consists of two subframes(5ms), and one subframe consists of 7 timeslots, (the structure of subframe is shown in section 7.2.1 of 3GPP TR 25.928), so the number of timeslot i should be 0, 1, ..., 6. In addition, for the 1.28Mcps chip rate TDD option, the DL reference measurement channel for 144kbps/s need two timeslots, each consists of 8 DPCH(SF=16). So the number of DPCH in each active TS should be 8.

8.3.8.2.5 Test requirements

Common with 3,84Mcps TDD option.

8.4 Receiver characteristics

8.4.1 General

Common with 3,84Mcps TDD option.

8.4.2 Reference sensitivity level

8.4.2.1 Definition and applicability

Common with 3,84Mcps TDD option.

8.4.2.2 Conformance requirements

For the measurement channel specified in Annex 8.A.2.1, the reference sensitivity level and performance of the BS shall be as specified in table section 6.3.2.1 of TR 25.945.

8.4.2.3 Test purpose

Common with 3,84Mcps TDD option.

8.4.2.4 Method of test

8.4.2.4.1 Initial conditions

- (1) Common with the 3.84Mcps chip rate
- (2) Common with the 3.84Mcps chip rate
- (3) Common with the 3.84Mcps chip rate.
- (4) The level of BS tester output signal measured at the BS antenna connector shall be adjusted to -110 dBm.

8.4.2.4.2 Procedure

Common with 3,84Mcps chip rate TDD option.

8.4.2.5 Test requirements

Common with 3,84Mcps TDD option.

[Explanation difference:]

There is no difference in the test method and test procedure between high chip rate TDD and low chip rate TDD, however the requirement is changed according to section 6.3.2.1 of TR 25.945.

8.4.3 Dynamic range

8.4.3.1 Definition and applicability

Common with 3,84Mcps TDD option.

8.4.3.2 Conformance requirements

The BER shall not exceed 0,001 for the parameters specified in table in section 6.3.3 of TR 25.945.

8.4.3.3 Test purpose

Common with 3,84Mcps TDD option.

8.4.3.4 Method of test

8.4.3.4.1 Initial conditions

Common with the 3.84Mcps chip rate

Common with the 3.84Mcps chip rate

Common with the 3.84Mcps chip rate.

The level of the BS tester output signal measured at the BS antenna connector shall be adjusted as specified in table in subclause 8.4.3.2

The power spectral density of the band-limited white noise source measured at the BS antenna connector shall be adjusted as specified in table in subclause 8.4.3.2. The minimum bandwidth of the white noise source shall be 1,5 times the chip rate (1,92 MHz for a chip rate of 1,28 Mcps).

8.4.3.4.2 Procedure

Common with 3,84Mcps chip rate TDD option.

8.4.3.5 Test requirement

Common with 3,84Mcps TDD option.

[Explanation difference:]

Due to the smaller bandwidth in low chip rate TDD the bandwidth of the white noise source is changed.

8.4.4 Adjacent Channel Selectivity (ACS)

8.4.4.1 Definition and applicability

Common with 3,84Mcps TDD option.

8.4.4.2 Conformance requirements

The BER, measured on the wanted signal in the presence of an interfering signal, shall not exceed

0,001 for the parameters specified in table in section 6.3.4 of TR 25.945.

8.4.4.3 Test purpose

Common with 3,84Mcps TDD option.

8.4.4.4 Method of test

8.4.4.4.1 Initial conditions

Common with the 3.84Mcps chip rate

Common with the 3.84Mcps chip rate

Start transmission from the BS tester to the BS using the UL reference measurement channel (12.2 kbps) defined in Annex 8.A of TR 25.945. The level of the UE simulator signal measured at the BS antenna connector shall be adjusted to the value specified in table in subclause 8.4.4.2

Set the signal generator to produce an interfering signal that is equivalent to a continuous narrow band CDMA signal with one code of chip frequency 1,28 Mchip/s, filtered by an RRC transmit pulse-shaping filter with roll-off $\alpha = 0,22$ and 1.6MHz bandwidth. The level of the interfering signal measured at the BS antenna connector shall be adjusted to the value specified in table in subclause 8.4.4.2

8.4.4.4.2 Procedure

Set the center frequency of the interfering signal to 1,6 MHz above the assigned channel frequency of the wanted signal.

Measure the BER of the wanted signal at the BS receiver.

Set the center frequency of the interfering signal to 1,6 MHz below the assigned channel frequency of the wanted signal.

Measure the BER of the wanted signal at the BS receiver.

Interchange the connections of the BS Rx ports and repeat the measurements according to steps (1) to (4).

8.4.4.5 Test requirements

The BER measured according subclause 8.4.4.4.2 to shall not exceed 0,001.

[Explanation difference:]

Because bandwidth of 1,28Mcps TDD option is 1,6MHz, the frequency offset of the interfering signal should be 1,6MHz.

8.4.5 Blocking characteristics

8.4.5.1 Definition and applicability

The blocking characteristics is a measure of the receiver ability to receive a wanted signal at its assigned channel frequency in the presence of an unwanted interferer on frequencies other than

those of the adjacent channels. The blocking performance shall apply at all frequencies as specified in tables in section 6.3.2 of TR 25.945 respectively, using a 1 MHz step size.

The requirements in this subclause shall apply to base stations intended for general-purpose applications.

8.4.5.2 Conformance requirements

The static reference performance as specified in the section 6.3.2 of TR 25.945 should be met with a wanted and an interfering signal coupled to the BS antenna input using the parameters specified in tables in section 6.3.5 of TR 25.945 respectively, using a 1 MHz step size..

8.4.5.3 Test purpose

The test stresses the ability of the BS receiver to withstand high-level interference from unwanted signals at frequency offsets of 3.2 MHz or more, without undue degradation of its sensitivity.

8.4.5.4 Method of test

8.4.5.4.1 Initial conditions

Connect an UE simulator operating at the assigned channel frequency of the wanted signal and a signal generator to the antenna connector of one Rx port.

Terminate or disable any other Rx port not under test.

Start transmission from the BS tester to the BS using the UL reference measurement channel (12.2 kbps) defined in Annex 8.A.2 of TR 25.945. The level of the UE simulator signal measured at the BS antenna connector shall be set to 6 dB above the reference sensitivity level specified section 6.3.2 of TR 25.945.

8.4.5.4.2 Procedure

Set the signal generator to produce an interfering signal at a frequency offset F_{uw} from the assigned channel frequency of the wanted signal which is given by

$$F_{uw} = \pm (n \times 1 \text{ MHz}),$$

where n shall be increased in integer steps from $n = 10$ up to such a value that the center frequency of the interfering signal covers the range from 1 MHz to 12,75 GHz. The interfering signal level measured at the antenna connector shall be set in dependency of its center frequency, as specified in tables in section 6.3.5 of TR 25.945. respectively. The type of the interfering signal is either equivalent to a continuous narrow band CDMA signal with one code of chip frequency 1,28 Mcps, filtered by an RRC transmit pulse-shaping filter with roll-off $\alpha = 0,22$, or a CW signal; see tables in section 6.3.5 of TR 25.945 respectively.

Common with 3,84Mcps chip rate TDD option.

Common with 3,84Mcps chip rate TDD option.

8.4.5.5 Test requirements

In all measurements made according to subclause 8.4.5.4.2, the BER shall not exceed 0,001.

[Explanation difference:]

Because the chip rate of the wanted signal is 1,28Mcps, the type of the interfering signal is either equivalent to a continuous narrow band CDMA signal with one code of chip frequency 1,28 Mchip/s.

8.4.6 Intermodulation characteristics

8.4.6.1 Definition and applicability

Common with 3,84Mcps TDD option.

8.4.6.2 Conformance requirements

The static reference performance as specified in clause 8.4.2 of TR 25.945 should be met when the following signals are coupled to the BS antenna input.

A wanted signal at the assigned channel frequency, 6 dB above the static reference level.

Two interfering signals with the parameters specified in following table.

Table 8.4.6-1: Parameters of the interfering signals for intermodulation characteristics testing of 1,28Mcps TDD option

Interfering Signal Level	Offset	Type of Interfering Signal
- 48 dBm	3,2 MHz	CW signal
- 48 dBm	6,4 MHz	NCDMA signal with one code

The reference for this requirement is TR 25.945 subclause 6.3.6.

8.4.6.3 Test purpose

Common with 3,84Mcps TDD option.

8.4.6.4 Method of test

8.4.6.4.1 Initial conditions

Common with 3,84Mcps chip rate TDD option.

Common with 3,84Mcps chip rate TDD option.

Start transmission from the BS tester to the BS using the UL reference measurement channel (12.2 kbps) defined in Annex 8.A.2 of TR 25.945 The level of the UE simulator signal measured at the BS antenna connector shall be set to 6 dB above the reference sensitivity level specified section 6.3.2 of TR 25.945.

Set the first signal generator to produce a CW signal with a level measured at the BS antenna connector of - 48 dBm.

Set the second signal generator to produce an interfering signal equivalent to a narrow band CDMA signal with one code of chip frequency 1,28 Mchip/s, filtered by an RRC transmit pulse-shaping filter with roll-off $\alpha = 0,22$. The level of the signal measured at the BS antenna connector shall be set to - 48 dBm.

8.4.6.4.2 Procedure

The frequency of the first and the second signal generator shall be set to 3,2 MHz and 6,4 MHz, respectively, above the assigned channel frequency of the wanted signal.

Measure the BER of the wanted signal at the BS receiver.

The frequency of the first and the second signal generator shall be set to 3,2 MHz and 6,4 MHz, respectively, below the assigned channel frequency of the wanted signal.

Measure the BER of the wanted signal at the BS receiver.

Interchange the connections of the BS Rx ports and repeat the measurements according to steps (1) to (4).

8.4.6.5 Test requirements

The BER measured according subclause 8.4.6.4.2 to shall not exceed 0,001.

[Explanation difference:]

Because the bandwidth of 1,28Mcps TDD is 1,6MHz, the frequency offsets of first and second interference signal should be 3,2MHz and 6,4MHz respectively.

8.4.7 Spurious emissions

8.4.7.1 Definition and applicability

Common with 3,84Mcps TDD option.

8.4.7.2 Conformance requirements

The power of any spurious emission shall not exceed the values given in table in section 6.3.7 of TR 25.945

8.4.7.3 Test requirements

Common with 3,84Mcps TDD option.

8.4.7.4 Method of test

8.4.7.4.1 Initial conditions

- (1) Common with the 3.84Mcps chip rate
- (2) Common with the 3.84Mcps chip rate
- (3) Common with the 3.84Mcps chip rate

(4) Set the BS to transmit a signal with parameters according to following table.

(5) Common with the 3.84Mcps chip rate

Table 8.4.7-1: Parameters of the transmitted signal for Rx spurious emissions test

Parameter	Value/description
TDD Duty Cycle	TS i ; $i = 0, 1, 2, \dots, 6$: transmit, if i is 0,4,5,6; receive, if i is 1,2,3.
BS output power setting	PRAT
Number of DPCH in each active TS	8
Power of each DPCH	1/8 of Base Station output power
Data content of DPCH	real life (sufficient irregular)

8.4.7.4.2 Procedure

(1) Measure the power of the spurious emissions by applying the measuring equipment with the settings as specified in following table. The characteristics of the measurement filter with the bandwidth 1,28 MHz shall be RRC with roll-off $\alpha = 0,22$. The characteristics of the measurement filters with bandwidths 100 kHz and 1 MHz shall be approximately Gaussian (typical spectrum analyzer filter). The center frequency of the filters shall be stepped in contiguous steps over the frequency bands as specified in following table. The time duration of each step shall be sufficiently long to capture one transmit time slot.

(2) If the BS is equipped with more than one Rx port, interchange the connections of the BS Rx ports and repeat the measurement according to (1).

Table 8.4.7-2: Measurement equipment settings

Stepped frequency range	Measurement bandwidth	Step width	Note	Detection mode
9 kHz – 1 GHz	100 kHz	100 kHz	With the exception of frequencies between 4 MHz below the first carrier frequency and 4 MHz above the last carrier frequency used by the BS	true RMS
1 GHz – 1,900 GHz	1 MHz	1 MHz		
1,900 GHz – 1,980 GHz	1,28 MHz	200 kHz		
1,980 GHz – 2,010 GHz	1 MHz	1 MHz		
2,010 GHz – 2,025 GHz	1,28 MHz	200 kHz		
2,025 GHz – 12,75 GHz	1 MHz	1 MHz		

8.4.7.5 Test requirements

The spurious emissions measured according to subclause 8.4.7.4.2 shall not exceed the limits specified in subclause 8.4.7.2.

[Explanation difference:]

For the 1.28Mcps chip rate TDD option, one frame(10ms) consists of two subframes(5ms), and one subframe consists of 7 timeslots, the structure of subframe is shown in section 7.2.1 of TR 25.928. So the number of timeslot i should be 0, 1,...,6. In addition, for the 1.28Mcps chip rate TDD option, the DL reference measurement channel for 144kbits/s need two timeslots, each consists of 8 DPCH(SF=16).So the number of DPCH in each active TS should be 8.

Due to the smaller bandwidth in low chip rate TDD the measurement bandwidth is changed.

8.5 Performance requirements

8.5.1 General

8.5.2. Demodulation in static propagation conditions

8.5.2.1 Demodulation of DCH

8.5.2.1.1 Definition and applicability

Common with 3,84Mcps TDD.

8.5.2.1.2 Conformance requirements

For the parameters specified in table 8.5.2.1.2.1, the BLER should not exceed the piece-wise linear BLER curve specified in table 8.5.2.1.2.2.

Table 8.5.2.1.2.1: Parameters in static propagation conditions for 1,28Mcps TDD option

Parameters	Unit	Test 1	Test 2	Test 3	Test 4
Number of DPCH _o		4	1	1	0
Spread factor of DPCH _o		8	8	8	
$\frac{DPCH_o - E_c}{I_{or}}$	dB	-7	-7	-7	-
I_{oc}	dBm/1,28 MHz	-91			
Information Data Rate	kbps	12,2	64	144	384

Table 8.5.2.1.2.2: Performance requirements in AWGN channel.

Test Number	$\frac{\hat{I}_{or}}{I_{oc}}$ [dB]	BLER
1		10^{-2}
2		10^{-1}
		10^{-2}
3		10^{-1}
		10^{-2}
4		10^{-1}
		10^{-2}

The reference for this requirement is TR 25.945 subclause 6.4.2.

8.5.2.1.3 Test purpose

Common with 3,84Mcps TDD option.

8.5.2.1.4 Method of test

8.5.2.1.4.1 Initial conditions

Connect the BS tester (UE simulator) generating the wanted signal and a set of interference generators to both BS antenna connectors for diversity reception via a combining network. The set of interference generators comprises a number of CDMA generators, each representing an individual intracell interferer (subsequently called DPCH₀ generators) that the DPCH₀s are synchronous, and an additional band-limited white noise source, simulating interference from other cells. Each DPCH₀ generator shall produce an interfering signal that is equivalent to a valid 1,28Mcps TDD signal with spreading factor 8, using the same time slot(s) than the wanted signal and applying the same cell-specific scrambling code. The number of the DPCH₀ generators used in each test is given in table 8.5.2.1.2.1.

8.5.2.1.4.2 Procedure

Adjust the power of the band-limited white noise source in such a way that its power spectral density measured at the BS antenna connector takes on the value I_{oc} as specified in table 8.5.2.1.2.1.

For a given test defined by the information data rate and the BLER objective, set the power of each DPCH₀ measured at the BS antenna connector during the active time slots to the value specified in table 8.5.2.1.4.2.1.

Set up a call between the BS tester generating the wanted signal and the BS. The characteristics of the call shall be configured according to the information data rate to be provided and the

corresponding UL reference measurement channel defined in Annex 8.A. Depending on the information data rate, the UL reference measurement channel makes use of one or two Dedicated Physical Channels (DPCH₁ and DPCH₂) with different spreading factors SF. The power(s) of DPCH₁ and DPCH₂ (if applicable) measured at the BS antenna connector during the active time slots shall be set to the value(s) given in table 8.5.2.1.4.2.1.

Measure the BLER of the wanted signal at the BS receiver.

Table 8.2.1.4.2.1: Parameters of DPCH₀ and the wanted signal

Test Number	BLER objective	Number of DPCH ₀	Power of each DPCH ₀ measured at the BS antenna connector [dBm]	Parameters of the wanted signal		
				DPCH	SF	Power measured at the BS antenna connector [dBm]
1	10 ⁻²	4		DPCH ₁	8	
2	10 ⁻¹	1		DPCH ₁	2	
	10 ⁻²	1		DPCH ₁	2	
3	10 ⁻¹	1		DPCH ₁	2	
	10 ⁻²	1		DPCH ₁	2	
4	10 ⁻¹	0	-	DPCH ₁	8	
				DPCH ₂	2	
	10 ⁻²	0	-	DPCH ₁	8	
				DPCH ₂	2	

8.5.2.1.5 Test requirements

The BLER measured according to subclause 8.5.2.1.4.2 shall not exceed the limits specified in table 8.5.2.1.2.2.

[Explanation difference:]

For the 1.28Mcps chip rate TDD option, one frame(10ms) consists of two subframes(5ms), and one subframe consists of 7 timeslots, (the structure of subframe is shown in TR 25.928). Considering the chip rate, the burst structure of 1,28Mcps TDD for normal traffic is different from that of 3,84Mcps TDD option, (the burst structure for normal traffic is shown in TR 25.928). So the propagation conditions, service mapping and simulation assumption of the measurement channel 12.2kps, 64pks, 144kps and 384kps should be different from those of 3,84Mcps TDD option. As a result, the relevant parameters should be different.

8.5.3. Demodulation of DCH in multipath fading conditions

8.5.3.1 Multipath fading Case 1

8.5.3.1.1 Definition and applicability

Common with 3,84Mcps TDD option.

8.5.3.1.2 Conformance requirements

For the parameters specified in table 8.5.3.1.2.1, the BLER should not exceed the piece-wise linear BLER curve specified in table 8.5.3.1.2.2.

Table 8.5.3.1.2.1: Parameters in static propagation conditions for 1,28Mcps TDD option

Parameters	Unit	Test 1	Test 2	Test 3	Test 4
Number of DPCH _o		4	1	1	0
Spread factor of DPCH _o		8	8	8	
$\frac{DPCH_o - E_c}{I_{or}}$	dB	-7	-7	-7	-
I_{oc}	dBm/1,28 MHz	-91			
Information Data Rate	kbps	12,2	64	144	384

Table 8.5.3.1.2.2: Performance requirements in AWGN channel.

Test Number	$\frac{\hat{I}_{or}}{I_{oc}}$ [dB]	BLER
1		10^{-2}
2		10^{-1}
		10^{-2}
3		10^{-1}
		10^{-2}
4		10^{-1}
		10^{-2}

The reference for this requirement is TR 25.945 subclause 6.4.2.

8.5.3.1.3 Test purpose

Common with 3,84Mcps TDD option.

8.5.3.1.4 Method of test

8.5.3.1.4.1 Initial conditions

(1) Connect the BS tester (UE simulator) generating the wanted signal and a set of interference generators to both BS antenna connectors for diversity reception via a combining network. The set of interference generators comprises a number of CDMA generators, each representing an individual intracell interferer (subsequently called DPCH_o generators) that the DPCH_os are synchronous, and an additional band-limited white noise source, simulating interference from other cells. Each DPCH_o generator shall produce an interfering signal that is equivalent to a valid 1,28Mcps TDD signal with spreading factor 8, using the same time slot(s) than the wanted signal and applying the same cell-specific scrambling code. The number of the DPCH_o generators used in each test is given in table 8.5.3.1.2.1.

(2) The wanted signal produced by the BS tester and the interfering signals produced by the DPCH₀ generators are individually passed through independent Multipath Fading Simulators (MFS) before entering the combining network. Each MFS shall be configured to simulate multipath fading Case 1.

8.5.3.1.4.2 Procedure

Adjust the power of the band-limited white noise source in such a way that its power spectral density measured at the BS antenna connector takes on the value I_{oc} as specified in table 8.5.3.1.2.1.

For a given test defined by the information data rate and the BLER objective, set the power of each DPCH₀ measured at the BS antenna connector during the active time slots to the value specified in table 8.5.3.1.4.2.1.

Set up a call between the BS tester generating the wanted signal and the BS. The characteristics of the call shall be configured according to the information data rate to be provided and the corresponding UL reference measurement channel defined in Annex 8.A. Depending on the information data rate, the UL reference measurement channel makes use of one or two Dedicated Physical Channels (DPCH₁ and DPCH₂) with different spreading factors SF. The power(s) of DPCH₁ and DPCH₂ (if applicable) measured at the BS antenna connector during the active time slots shall be set to the value(s) given in table 8.5.3.1.4.2.1.

Measure the BLER of the wanted signal at the BS receiver.

Table 8.5.3.1.4.2.1: Parameters of DPCH₀ and the wanted signal

Test Number	BLER objective	Number of DPCH ₀	Power of each DPCH ₀ measured at the BS antenna connector [dBm]	Parameters of the wanted signal		
				DPCH	SF	Power measured at the BS antenna connector [dBm]
1	10^{-2}	4		DPCH ₁	8	
2	10^{-1}	1		DPCH ₁	2	
	10^{-2}	1		DPCH ₁	2	
3	10^{-1}	1		DPCH ₁	2	
	10^{-2}	1		DPCH ₁	2	
4	10^{-1}	0	–	DPCH ₁	8	
				DPCH ₂	2	
	10^{-2}	0	–	DPCH ₁	8	
				DPCH ₂	2	

8.5.3.1.5 Test requirements

The BLER measured according to subclause 8.5.3.1.4.2 shall not exceed the limits specified in table 8.5.3.1.2.2.

[Explanation difference:]

For the 1.28Mcps chip rate TDD option, one frame(10ms) consists of two subframes(5ms), and one subframe consists of 7 timeslots, (the structure of subframe is shown in TR 25.928). Considering the chip rate, the burst structure of 1,28Mcps TDD for normal traffic is

different from that of 3,84Mcps TDD option, (the burst structure for normal traffic is shown in TR 25.928). So the propagation conditions, service mapping and simulation assumption of the measurement channel 12.2kps, 64kps, 144kps and 384kps should be different from those of 3,84Mcps TDD option. As a result, the relevant parameters should be different.

8.5.3.2 Multipath fading Case 2

8.5.3.2.1 Definition and applicability

Common with 3,84Mcps TDD option.

8.5.3.2.2 Conformance requirements

For the parameters specified in table 8.5.3.2.2.1, the BLER should not exceed the piece-wise linear BLER curve specified in table 8.5.3.2.2.2.

Table 8.5.3.2.2.1: Parameters in static propagation conditions for 1,28Mcps TDD option

Parameters	Unit	Test 1	Test 2	Test 3	Test 4
Number of DPCH _o		4	1	1	0
Spread factor of DPCH _o		8	8	8	
$\frac{DPCH_o - E_c}{I_{or}}$	dB	-7	-7	-7	-
I_{oc}	dBm/1,28 MHz	-91			
Information Data Rate	kbps	12,2	64	144	384

Table 8.5.3.2.2.2: Performance requirements in AWGN channel.

Test Number	$\frac{\hat{I}_{or}}{I_{oc}}$ [dB]	BLER
1		10^{-2}
2		10^{-1}
		10^{-2}
3		10^{-1}
		10^{-2}
4		10^{-1}
		10^{-2}

The reference for this requirement is TR 25.945 subclause 6.4.2.

8.5.3.2.3 Test purpose

Common with 3,84Mcps TDD option.

8.5.3.2.4 Method of test

8.5.3.2.4.1 Initial conditions

(1) Connect the BS tester (UE simulator) generating the wanted signal and a set of interference generators to both BS antenna connectors for diversity reception via a combining network. The set of interference generators comprises a number of CDMA generators, each representing an individual intracell interferer (subsequently called DPCH₀ generators) that the DPCH₀s are synchronous, and an additional band-limited white noise source, simulating interference from other cells. Each DPCH₀ generator shall produce an interfering signal that is equivalent to a valid 1,28Mcps TDD signal with spreading factor 8, using the same time slot(s) than the wanted signal and applying the same cell-specific scrambling code. The number of the DPCH₀ generators used in each test is given in table 8.5.3.2.2.1.

(2) The wanted signal produced by the BS tester and the interfering signals produced by the DPCH₀ generators are individually passed through independent Multipath Fading Simulators (MFS) before entering the combining network. Each MFS shall be configured to simulate multipath fading Case 2.

8.5.3.2.4.2 Procedure

Adjust the power of the band-limited white noise source in such a way that its power spectral density measured at the BS antenna connector takes on the value I_{oc} as specified in table 8.5.3.2.2.1.

For a given test defined by the information data rate and the BLER objective, set the power of each DPCH₀ measured at the BS antenna connector during the active time slots to the value specified in table 8.5.3.2.4.2.1.

Set up a call between the BS tester generating the wanted signal and the BS. The characteristics of the call shall be configured according to the information data rate to be provided and the corresponding UL reference measurement channel defined in Annex 8.A. Depending on the information data rate, the UL reference measurement channel makes use of one or two Dedicated Physical Channels (DPCH₁ and DPCH₂) with different spreading factors SF. The power(s) of DPCH₁ and DPCH₂ (if applicable) measured at the BS antenna connector during the active time slots shall be set to the value(s) given in table 8.5.3.2.4.2.1.

Measure the BLER of the wanted signal at the BS receiver.

Table 8.5.3.2.4.2.1: Parameters of DPCH₀ and the wanted signal

Test Number	BLER objective	Number of DPCH ₀	Power of each DPCH ₀ measured at the BS antenna connector [dBm]	Parameters of the wanted signal		
				DPCH	SF	Power measured at the BS antenna connector [dBm]
1	10 ⁻²	4		DPCH ₁	8	
2	10 ⁻¹	1		DPCH ₁	2	
	10 ⁻²	1		DPCH ₁	2	
3	10 ⁻¹	1		DPCH ₁	2	
	10 ⁻²	1		DPCH ₁	2	
4	10 ⁻¹	0	-	DPCH ₁	8	
				DPCH ₂	2	
	10 ⁻²	0	-	DPCH ₁	8	
				DPCH ₂	2	

8.5.3.2.5 Test requirements

The BLER measured according to subclause 8.5.3.2.4.2 shall not exceed the limits specified in table 8.5.3.2.2.2.

[Explanation difference:]

For the 1.28Mcps chip rate TDD option, one frame(10ms) consists of two subframes(5ms), and one subframe consists of 7 timeslots, (the structure of subframe is shown in TR 25.928). Considering the chip rate, the burst structure of 1,28Mcps TDD for normal traffic is different from that of 3,84Mcps TDD option, (the burst structure for normal traffic is shown in TR 25.928). So the propagation conditions, service mapping and simulation assumption of the measurement channel 12.2kps, 64pkps, 144kps and 384kps should be different from those of 3,84Mcps TDD option. As a result, the relevant parameters should be different.

8.5.3.3 Multipath fading Case 3

8.5.3.3.1 Definition and applicability

Common with 3,84Mcps TDD option.

8.5.3.3.2 Conformance requirements

For the parameters specified in table 8.5.3.3.2.1, the BLER should not exceed the piece-wise linear BLER curve specified in table 8.5.3.3.2.2.

Table 8.5.3.3.2.1: Parameters in static propagation conditions for 1,28Mcps TDD option

Parameters	Unit	Test 1	Test 2	Test 3	Test 4
Number of DPCH ₀		4	1	1	0
Spread factor of DPCH ₀		8	8	8	
$\frac{DPCH_{0} - E_c}{I_{or}}$	dB	-7	-7	-7	-
I _{oc}	dBm/1,28 MHz	-91			
Information Data Rate	kbps	12,2	64	144	384

Table 8.5.3.3.2.2: Performance requirements in AWGN channel.

Test Number	$\frac{\hat{I}_{or}}{I_{oc}}$ [dB]	BLER
1		10 ⁻²
2		10 ⁻¹
		10 ⁻²
3		10 ⁻¹
		10 ⁻²
4		10 ⁻¹
		10 ⁻²

The reference for this requirement is TR 25.945 subclause 6.4.2.

8.5.3.3.3 Test purpose

Common with 3,84Mcps TDD option.

8.5.3.3.4 Method of test

8.5.3.3.4.1 Initial conditions

(1) Connect the BS tester (UE simulator) generating the wanted signal and a set of interference generators to both BS antenna connectors for diversity reception via a combining network. The set of interference generators comprises a number of CDMA generators, each representing an individual intracell interferer (subsequently called DPCH₀ generators) that the DPCH₀s are synchronous, and an additional band-limited white noise source, simulating interference from other cells. Each DPCH₀ generator shall produce an interfering signal that is equivalent to a valid 1,28Mcps TDD signal with spreading factor 8, using the same time slot(s) than the wanted signal and applying the same cell-specific scrambling code. The number of the DPCH₀ generators used in each test is given in table 8.5.3.3.2.1.

(2) The wanted signal produced by the BS tester and the interfering signals produced by the DPCH₀ generators are individually passed through independent Multipath Fading Simulators (MFS) before entering the combining network. Each MFS shall be configured to simulate multipath fading Case 3.

8.5.3.3.4.2 Procedure

Adjust the power of the band-limited white noise source in such a way that its power spectral density measured at the BS antenna connector takes on the value I_{oc} as specified in table 8.5.3.3.2.1.

For a given test defined by the information data rate and the BLER objective, set the power of each $DPCH_0$ measured at the BS antenna connector during the active time slots to the value specified in table 8.5.3.3.4.2.1.

Set up a call between the BS tester generating the wanted signal and the BS. The characteristics of the call shall be configured according to the information data rate to be provided and the corresponding UL reference measurement channel defined in Annex 8.A. Depending on the information data rate, the UL reference measurement channel makes use of one or two Dedicated Physical Channels ($DPCH_1$ and $DPCH_2$) with different spreading factors SF. The power(s) of $DPCH_1$ and $DPCH_2$ (if applicable) measured at the BS antenna connector during the active time slots shall be set to the value(s) given in table 8.5.3.3.4.2.1.

Measure the BLER of the wanted signal at the BS receiver.

Table 8.5.3.3.4.2.1: Parameters of $DPCH_0$ and the wanted signal

Test Number	BLER objective	Number of $DPCH_0$	Power of each $DPCH_0$ measured at the BS antenna connector [dBm]	Parameters of the wanted signal		
				DPCH	SF	Power measured at the BS antenna connector [dBm]
1	10^{-2}	4		$DPCH_1$	8	
2	10^{-1}	1		$DPCH_1$	2	
	10^{-2}	1		$DPCH_1$	2	
3	10^{-1}	1		$DPCH_1$	2	
	10^{-2}	1		$DPCH_1$	2	
4	10^{-1}	0	–	$DPCH_1$	8	
				$DPCH_2$	2	
	10^{-2}	0	–	$DPCH_1$	8	
				$DPCH_2$	2	

8.5.3.3.5 Test requirements

The BLER measured according to subclause 8.5.3.3.4.2 shall not exceed the limits specified in table 8.5.3.3.2.2.

[Explanation difference:]

For the 1.28Mcps chip rate TDD option, one frame(10ms) consists of two subframes(5ms), and one subframe consists of 7 timeslots, (the structure of subframe is shown in TR 25.928). Considering the chip rate, the burst structure of 1,28Mcps TDD for normal traffic is different from that of 3,84Mcps TDD option, (the burst structure for normal traffic is shown in TR 25.928). So the propagation conditions, service mapping and simulation assumption of the measurement channel 12.2kps, 64kps, 144kps and 384kps should be different from those of 3,84Mcps TDD option. As a result, the relevant parameters should be different.

Annex 8.A (normative): Measurement Channels

8.A.1: General

8.A.2: Reference measurement channel

8.A.2.1 UL reference measurement channel (12.2 kbps)

Parameter	
Information data rate	12.2 kbps
RU's allocated	1TS (1*SF8) = 2RU/5ms
Midamble	144
Interleaving	20 ms
Power control (TPC)	4 Bit/user/10ms
TFCI	16 Bit/user/10ms
Synchronisation Shift (SS)	4 Bit/user/10ms
Inband signalling DCCH	2 kbps
Puncturing level at Code rate 1/3: DCH / DCCH	33% / 33%

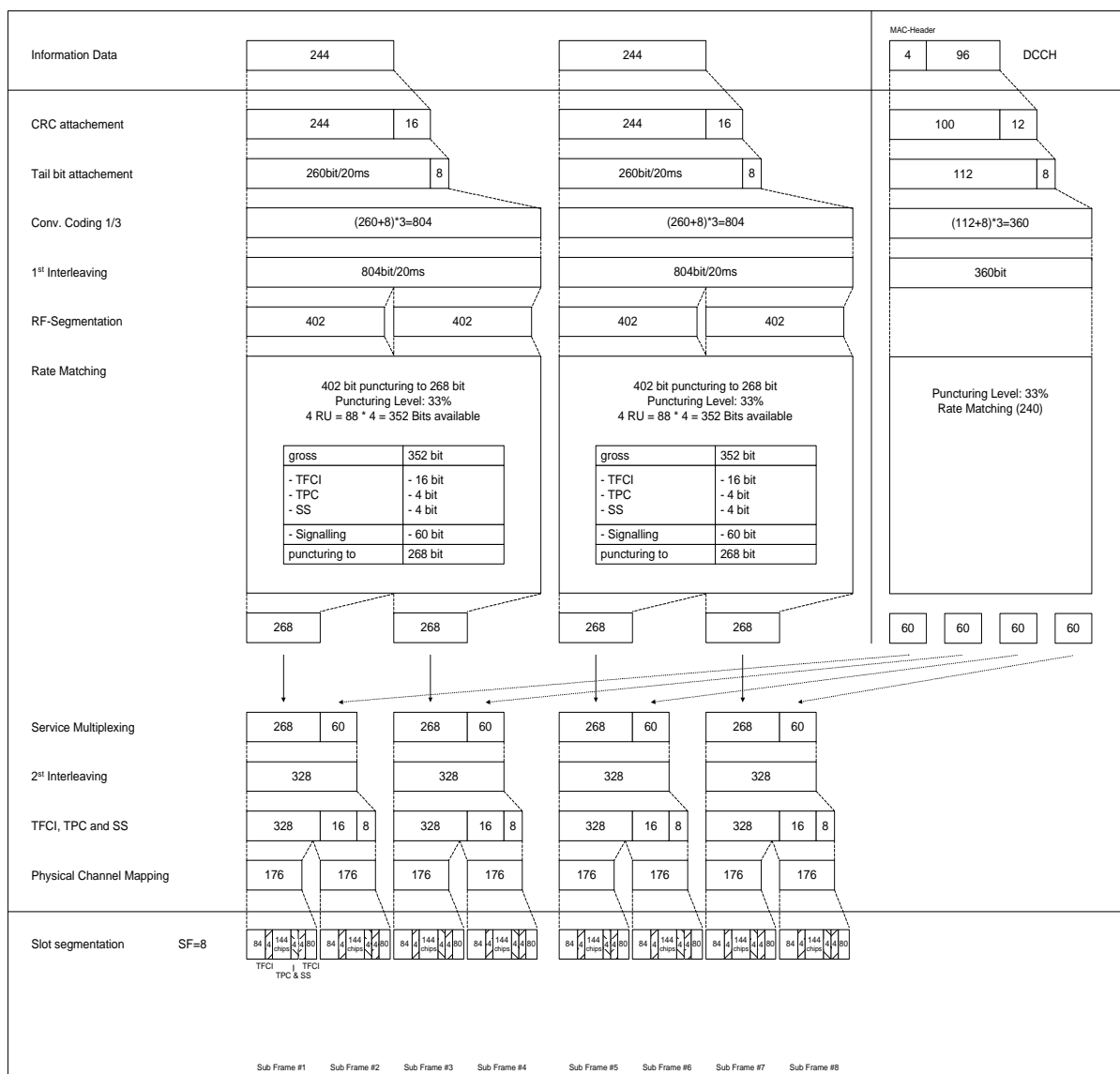

8.A.2.2 UL reference measurement channel (64 kbps)

Parameter	
Information data rate	64 kbps
RU's allocated	1TS (1*SF2) = 8RU/5ms
Midamble	144
Interleaving	20 ms
Power control (TPC)	4 Bit/user/10ms
TFCI	16 Bit/user/10ms
Synchronisation Shift (SS)	4 Bit/user/10ms
Inband signalling DCCH	2 kbps
Puncturing level at Code rate: 1/3 DCH / 1/2 DCCH	32% / 0

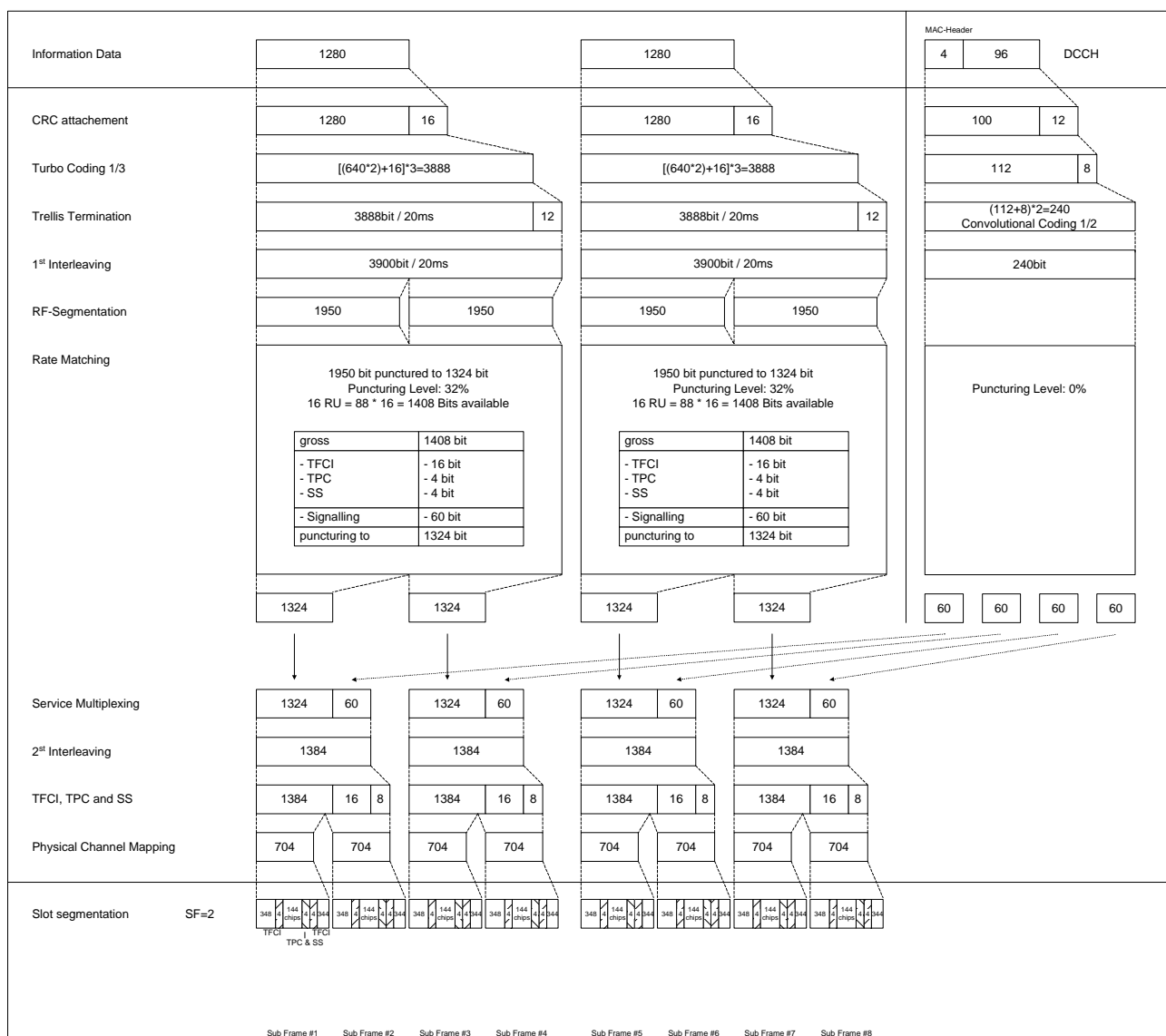

8.A.2.3 UL reference measurement channel (144 kbps)

Parameter	
Information data rate	144 kbps
RU's allocated	2TS (1*SF2) = 16RU/5ms
Midamble	144
Interleaving	20 ms

Power control (TPC)	8 Bit/user/10ms
TFCI	32 Bit/user/10ms
Synchronisation Shift (SS)	8 Bit/user/10ms
Inband signalling DCCH	2 kbps
Puncturing level at Code rate: 1/3 DCH / 1/2 DCCH	38% / 7%

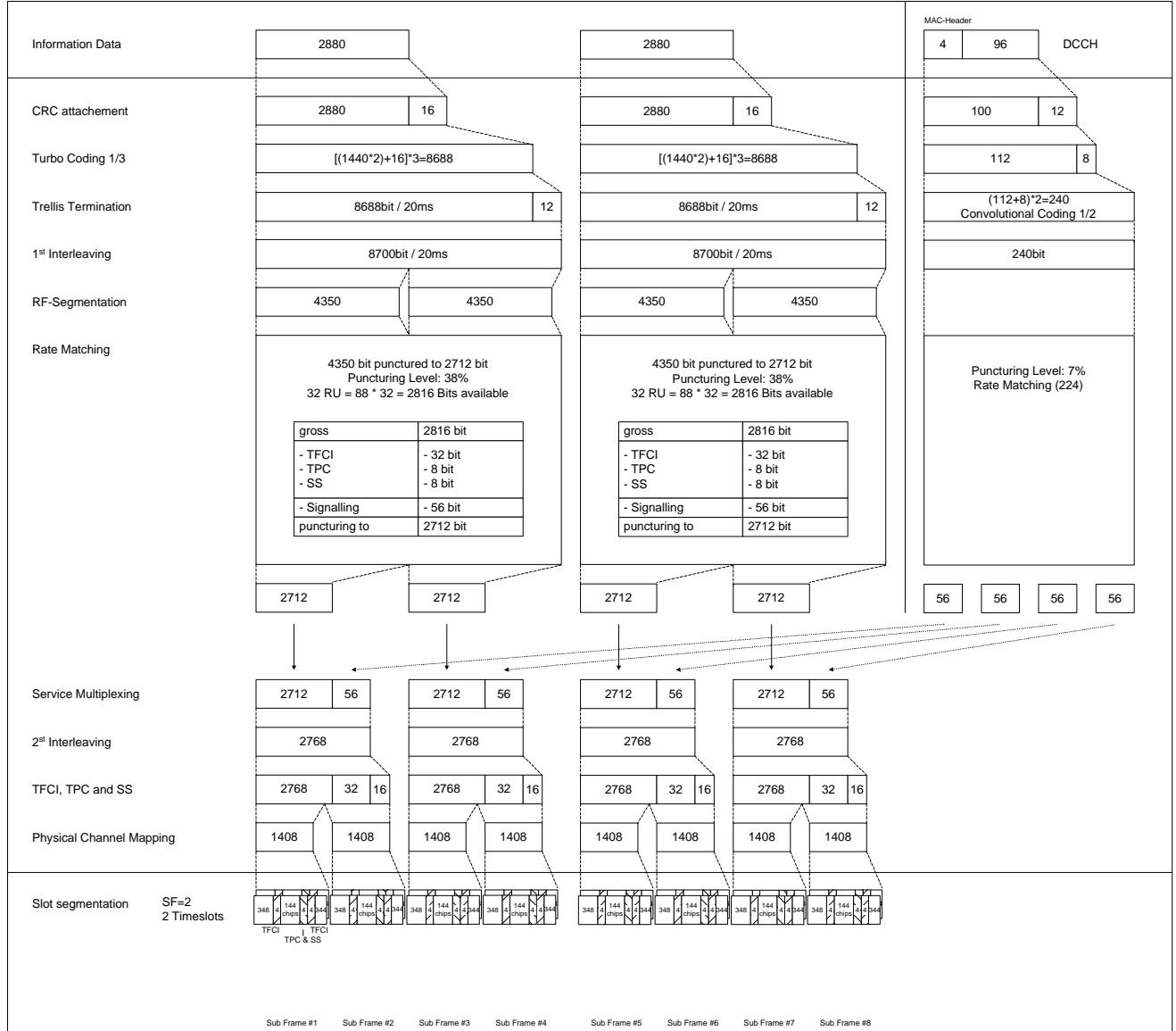

8.A.2.4 UL reference measurement channel (384 kbps)

Parameter	
Information data rate	384 kbps
RU's allocated	4TS (1*SF2 + 1*SF8) = 40RU/5ms
Midamble	144
Interleaving	20 ms
Power control (TPC)	16 Bit/user/10ms
TFCI	64 Bit/user/10ms
Synchronisation Shift (SS)	16 Bit/user/10ms
Inband signalling DCCH	2 kbps
Puncturing level at Code rate: 1/3 DCH / 1/2 DCCH	41% / 12%

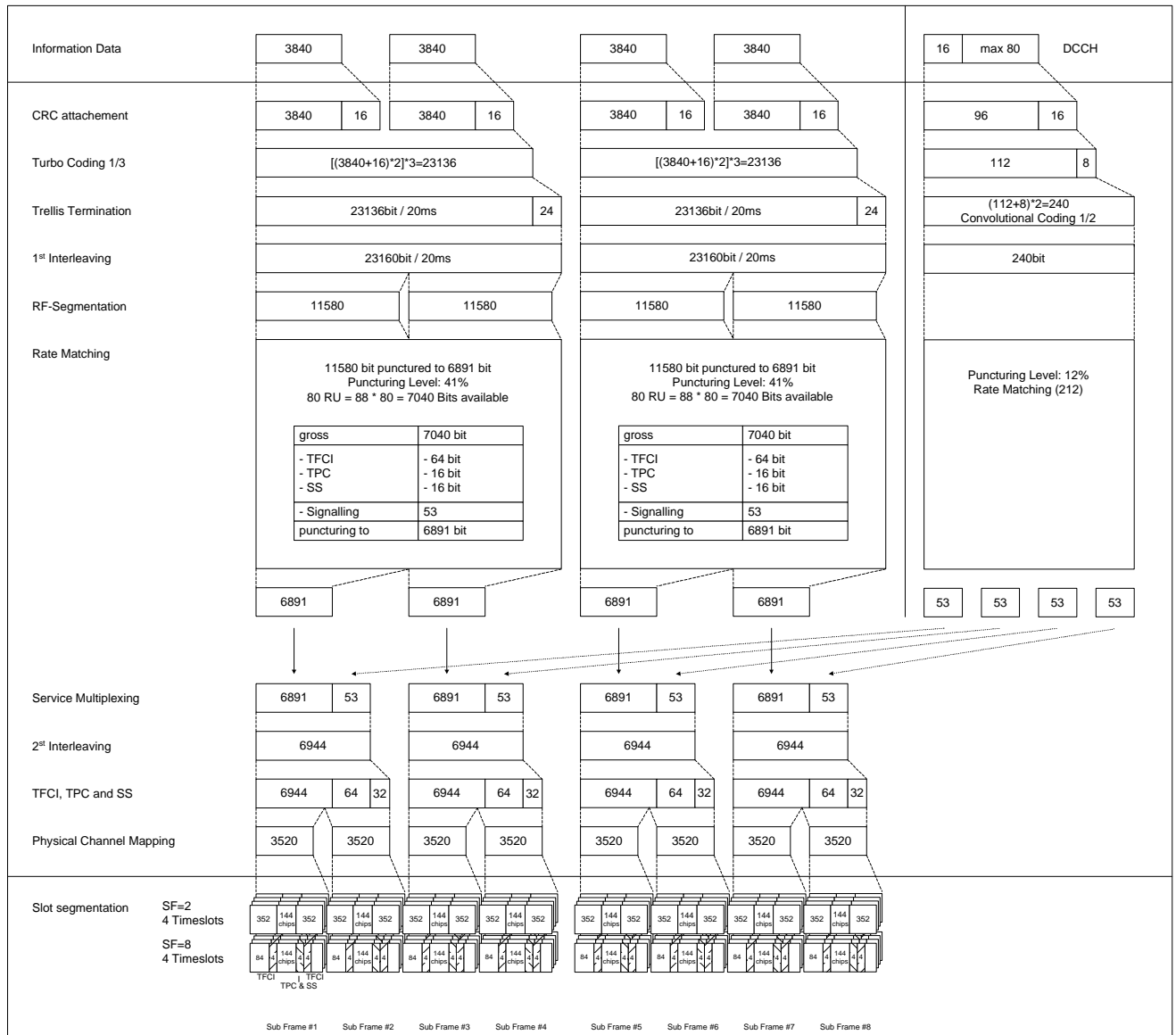

[Explanation difference:]

For the 1.28Mcps chip rate TDD option, one frame (10ms) consists of two sub-frames(5ms), and one

Sub-frame consists of 7 timeslots. The structure of timeslot in 1.28Mcps chip rate TDD (shown inTR25.928) is different from the structure of timeslot in 3.84Mcps TDD. So the service mapping of variance data rate of 1.28Mcps chip rate TDD option is different from that of 3.84Mcps chip rate TDD option.

Annex 8.B (normative): Propagation conditions

8.B.1 Static Propagation conditions

The propagation for the static performance measurement is an Additive White Gaussian Noise (AWGN) environment. No fading and multi-path exist for the propagation model.

8.B.2 multi-path fading Propagation conditions

Table 8.B.2-1 shows propagation conditions that are used for the performance measurements in multi-path fading environment. All taps have classical Doppler spectrum.

Table 8.B.2-1: Propagation Conditions for Multi-Path Fading Environments

Case 1, speed 3km/h		Case 2, speed 3km/h		Case 3, speed 120km/h	
Relative Delay [ns]	Average Power [dB]	Relative Delay [ns]	Average Power [dB]	Relative Delay [ns]	Average Power [dB]
0	0	0	0	0	0
2928	-10	2928	0	781	-3
		12000	0	1563	-6
				2344	-9

[Rationale]:

The channel estimation can only resolve paths with are separated by at least one chip in delay. Otherwise the paths fall into the same tap. Even though this happens in realistic environments, it is not useful to base the propagation models for the performance requirements on a scenario with a delay spread of less than 1 chip, because the baseband is not tested in this case. Therefore, it is proposed to keep the same delay for the path in units of chips for the 1.28Mcps chip rate TDD-mode as for the 3.84Mcps chip rate TDD-mode. The tap delays in units of time are changed accordingly to take into account the difference in the chip rate. Due to the request to have the same maximum delay spread for 1.28Mcps chip rate TDD as for 3.84Mcps chip rate TDD, the delay spread of tap 3rd for the case 2 propagation conditions is set to 12 ms.:

Annex 8.C (normative): Global in-channel Tx test

8.C.1: General

Description is common with 3,84Mcps TDD option.

8.C.2: Definition of the process

8.C.2.1 Basic principle

Description is common with 3,84Mcps TDD option.

8.C.2.2 Output signal of the Tx under test

Description is common with 3,84Mcps TDD option

8.C.2.3 Reference signal

Description is common with 3,84Mcps TDD option

8.C.2.4 Classification of measurement results

Description is common with 3,84Mcps

8.C.2.5 Process definition to achieve results of type “deviation”

Description is common with 3,84Mcps TDD option.

8.C.2.6 Process definition to achieve results of type “residual”

Description is common with 3,84Mcps TDD option.

8.C.2.6.1 Error Vector Magnitude (EVM)

Description is common with 3,84Mcps TDD option.

8.C.2.6.2 Peak Code Domain Error (PCDE)

Description is common with 3,84Mcps TDD option.

8.C.3: Applications

This process may be applied in the measurements defined in the following subclauses:

8.3.3 Frequency Stability

8.3.4 Output Power Dynamics

- 8.3.4.2 Power control steps
- 8.3.4.3 Power control dynamic range
- 8.3.4.4 Minimum transmit power
- 8.3.4.5 Primary CCPCH power
- 8.3.6.2.2 Adjacent Channel Leakage power Ratio (ACLR)
- 8.3.8 Transmit Modulation
 - 8.3.8.1 Modulation accuracy
 - 8.3.8.2 Peak Code Domain Error

8.C.4 Notes

NOTE: Symbol length

Description is common with 3,84Mcps TDD option

NOTE: Deviation

Description is common with 3,84Mcps TDD option.

NOTE: Residual

Description is common with 3,84Mcps TDD option.

NOTE: Scrambling code

Description is common with 3,84Mpcs TDD option.

NOTE: TDD

Description is common with 3,84Mcps TDD option.

[Rationale:]

The global in-channel Tx test enables the measurement of all relevant parameters that describe the in-channel quality of the output signal of the Tx under test in a single measurement process, not only FDD and all options of TDD.

9 RF System scenarios

9.1 General

To develop the 3GPP standard, all the relevant scenarios need to be considered and the most critical cases need to be identified for the various aspects of operation so that final parameters can be derived to meet both service and implementation requirements.

Parameters possibly influenced by the scenarios are listed in 25.102, 25.105 and 25.945. These

include, but are not limited to:

Out of band emissions;

Spurious emissions;

Intermodulation rejection;

Intermodulation between MS;

Blocking.

9.2 Methodology for coexistence studies 1.28Mcps
TDD / FDD

9.3 Methodology for coexistence studies 1.28Mcps
TDD / 3.84Mcps TDD

9.4 Methodology for coexistence studies 1.28Mcps
TDD / 1.28Mcps TDD

9.5 Results, implementation issues and
recommendations

9.5.1 1.28Mcps TDD /FDD

9.5.2 1.28Mcps TDD / 3.84Mcps TDD

9.5.3 1.28Mcps TDD / 1.28Mcps TDD

9.6 Information and General purpose materials

9.6.1 CDMA Definitions and Equations

9.6.1.1 CDMA-related definitions

The following CDMA-related abbreviations and definitions are used in various 3GPP WG4 documents.

<i>Chip Rate</i>	1.28M chips per second.
$DwPTS _ E_c$	Average energy per PN chip for DwPTS.
$DwPTS \frac{E_c}{I_o}$	The ratio of the received energy per PN chip for DwPTS to the total received power spectral density at the UE antenna connector.

$\frac{DwPTS - E_c}{I_{or}}$	The ratio of the average transmit energy per PN chip for DwPTS to the total transmit power spectral density.
------------------------------	--

[Explanation difference:]

For 1.28Mcps chip rate TDD option, the frame length is 10ms and the 10ms is divided into 2 sub-frames of 5 ms. Each subframe is composed of 7 normal traffic time slots and two special pilot slots, i.e., DwPTS for downlink and UpPTS for uplink.

For 1.28Mcps chip rate TDD option, the other CDMA related definitions have the same meaning as for 3.84Mcps TDD.

9.6.1.2 CDMA equations

The equations listed below describe the relationship between various parameters under different conditions.

9.6.1.2.1 BS Transmission Power

Transmit power of the Base Station is normalized to 1 and can be presented as

$$\frac{DPCH - E_c}{I_{or}} + \frac{SCCPCH - E_c}{I_{or}} + \frac{OCNS - E_c}{I_{or}} = 1 \quad (\text{Normal downlink timeslots})$$

$$\frac{PCCPCH - E_c}{I_{or}} = 1 \quad (\text{Timeslot 0})$$

$$\frac{DwPTS - E_c}{I_{or}} = 1 \quad (\text{DwPTS})$$

Explanations:

1.28 Mcps TDD option has special frame structure; its TS0 is only used for downlink so the position of P-CCPCH is fixed. DwPTS and UpPTS are unique slots so separate equations are need for them.

9.7 Link Level performances

9.7.1 Simulation results for 1,28Mcps TDD performace

9.7.1.1 Simulation assumptions

9.7.1.1.1 Simulation chain

9.7.1.1.1.1 Downlink

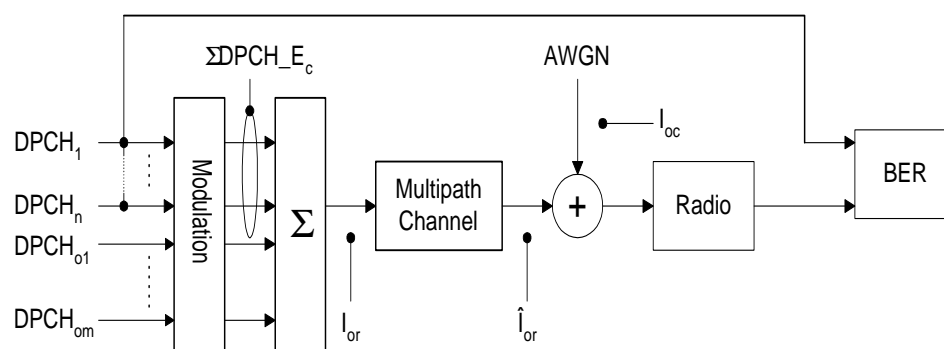

Because joint detection is considered for the low chip rate TDD option, the simulation has to differ from the wideband TDD simulation. An orthogonal channel noise simulator (OCNS) can not be used, instead all intracell interferer have to be modelled individually. The simulation chain is shown in the figure below.

Figure 1: Downlink simulation chain

I_{oc} represents the intercell interference and other noise contributions, and $DPCH_{oi}$ for $i=1$ to m are the individual intracell interferer. Each intracell interferer $DPCH_{oi}$ is modelled by one code with $Q=16$. $DPCH_1$ to $DPCH_n$ are the DPCH for the service under investigation. All $DPCH_i$ for $i=1$ to n and $DPCH_{oj}$ for $j=1$ to m have the same chip energy $DPCH_{E_c}$. Note that in the downlink all codes have a spreading factor of 16 for all reference measurement channels. The ratio of \hat{I}_{or} to I_{oc} is varied until the BLER target is reached, and

$$\Sigma DPCH_{E_c} = n \cdot DPCH_{E_c}.$$

For the performance requirement test, the ratio of \hat{I}_{or} to I_{oc} is increased by the implementation margin.

9.7.1.1.1.2 Uplink

In the uplink the same simulation chain as for wide-band TDD is used. The uplink simulation chain is shown in figure 2.

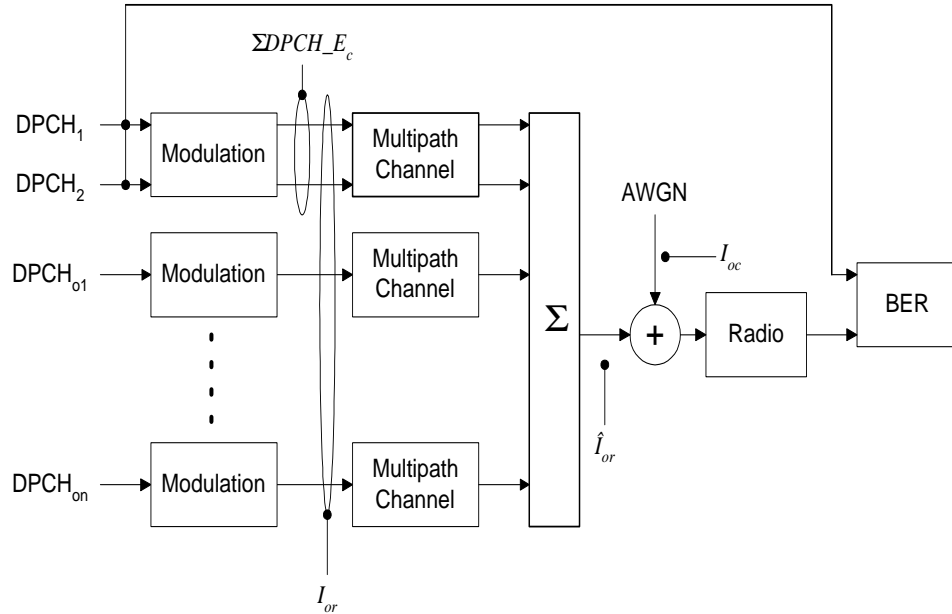

Figure 2: Uplink simulation chain

DPCH₁ and DPCH₂ are the DPCH for the service under investigation. DPCH_{oi} for $i=1$ to n is one code with the spreading factor 8. The ratio of \hat{I}_{or} to I_{oc} is varied until the BLER target is reached.

For the reference measurement channel one or two codes with different spreading factors are used. The following equations apply for the chip energy:

$$\frac{DPCH_{1-E_c}}{DPCH_{2-E_c}} = \frac{Q_2}{Q_1} \quad \text{and} \quad \frac{DPCH_{oi-E_c}}{\Sigma DPCH_{-E_c}} = \frac{\frac{Q_1 Q_2}{(Q_1 + Q_2)}}{8},$$

where Q_1 and Q_2 refer to the spreading factors of DPCH₁ and DPCH₂ and

$$\Sigma DPCH_{-E_c} = DPCH_{1-E_c} + DPCH_{2-E_c}.$$

If only a single code is used for the service under investigation, DPCH_{2-E_c} is null. In this case the following formula applies:

$$\frac{DPCH_{1-E_c}}{DPCH_{oi-E_c}} = \frac{8}{Q_1}$$

The implementation margin is encountered in the intercell interference ratio \hat{I}_{oi}/I_{oc} .

9.7.1.1.2 Simulation Assumptions

9.7.1.1.2.1 General

Parameter	Explanation/Assumption
Chip Rate	1.28 Mcps
Duration of TDMA sub-frame	5 ms
Number of time slots per sub-frame	7
Closed loop power control	OFF
AGC	OFF
Number of samples per chip	1 sample per chip
Propagation Conditions	See Tdoc R400TDD051
Numerical precision	Floating point simulations
BLER target	10E-1; 10E-2; 10E-3
BLER calculation	BLER will be calculated by comparing with transmitted and received bits.
DCCH model	Random symbols transmitted, not evaluated in the receiver
TPC and SS model	Random symbols transmitted, not evaluated in the receiver
TFCI model	Random symbols, not evaluated in the receiver but it is assumed that receiver gets error free reception of TFCI information
Turbo decoding	Max Log Map with 4 iterations
Measurement Channels	See Tdoc R400TDD052
Other L1 parameters	As Specified in latest L1 specifications
Cell parameter	0 (this determines the scrambling and basic midamble code)

9.7.1.1.2.2 Additional downlink parameters

\hat{I}_{or}/I_{oc}	Ratio to meet the required BLER target				
	Bit rate	Static	Case 1	Case 2	Case 3
# of DPCH _{oi}	12.2 kbps	8	8	8	8
	64 kbps	2	2	2	2
	144 kbps	2	2	2	2
	384 kbps	0	0	0	0
Number of timeslots per sub-frame per user	12.2 kbps: TS=1 64 kbps: TS=1 144 kbps: TS=2 384 kbps: TS=4				
Transmit diversity, "TxAA", "TSTD"	OFF				
Receiver antenna diversity	OFF				
Midamble	Common midamble (See TR25.928v1.1.0 chapter 7.2.5)				
Channelisation codes C(k; Q) (see TR25.928v1.1.0 chapter 9.2.2)		12.2 kbps	64 kbps	144 kbps	384 kbps
	DPCH _i	C(i; 16)	C(i; 16)	C(i; 16)	C(i; 16)
	DPCH _{oi}	C(j+2; 16)	C(j+8; 16)	C(j+8; 16)	-
Receiver	Joint Detector (ZF-BLE)				
Channel Estimation	Ideal multipath delay estimation and joint channel estimator according to article from Steiner and Baier in Freq., vol. 47, 1993, pp.292-298, based on correlation to obtain the complex amplitudes for the path.				

9.7.1.1.2.3 Additional uplink parameters

Channel Estimation	Ideal multipath delay estimation and joint channel estimator according to article from Steiner and Baier in Freq., vol. 47, 1993, pp.292-298, based on correlation to obtain the complex amplitudes for the path.				
Receiver antenna diversity	ON (2 antennas)				
\hat{I}_{or}/I_{oc} [dB]	Parameter to meet the required BLER				
# of DPCH _{oi}	Bit rate	Static	Case 1	Case 2	Case 3
	12.2 kbps	4	4	4	4
	64 kbps	1	1	1	1
	144 kbps	1	1	1	1
384 kbps	0	0	0	0	0
	Number of timeslots per frame per user 12.2 kbps: TS=1 64 kbps: TS=1 144 kbps: TS=2 384 kbps: TS=4				
Channelisation codes C(k; Q) (see TR25.928v1.1.0 chapter 9.2.2)		12.2 kbps	64 kbps	144 kbps	384 kbps
	DPCH ₁	C(1; 8)	C(1; 2)	C(1; 2)	C(1; 2)
	DPCH ₂	-	-	-	C(5; 8)
	DPCH _{oi}	C(i+1; 8)	C(i+4; 8)	C(i+4; 8)	-
Midamble	UE specific (See TR25.928v1.1.0 chapter 7.2.5)				
Receiver	Multi-User Detection (ZF-BLE)				

9.7.1.2 Simulation results

9.7.1.2.1 12.2kps service

9.7.1.2.1.1 Graphical Presentation of 12.2 kbps service UL Simulation Results

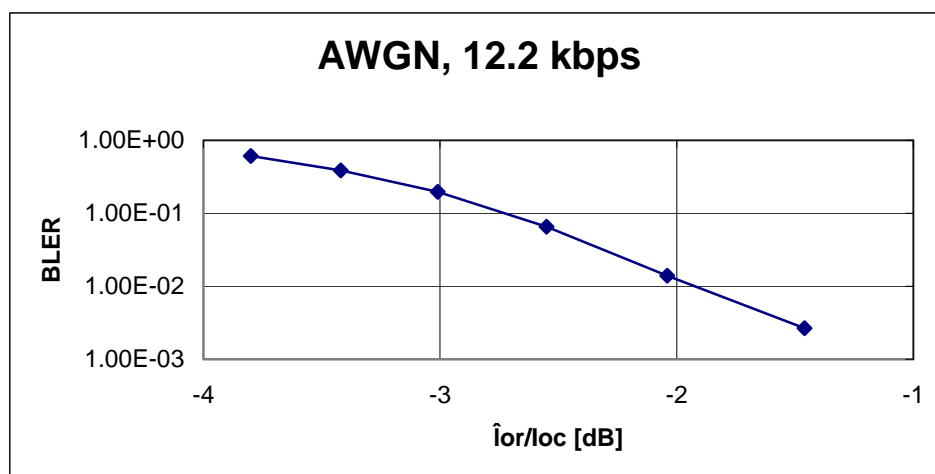

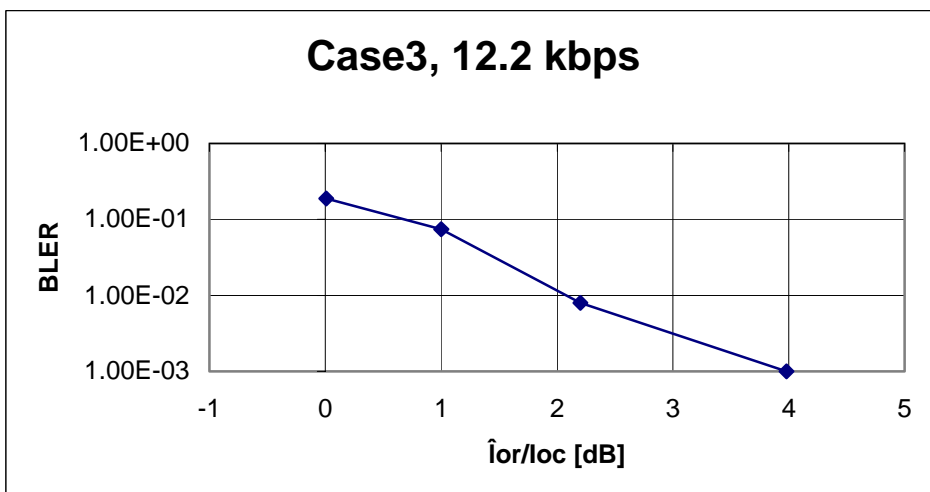
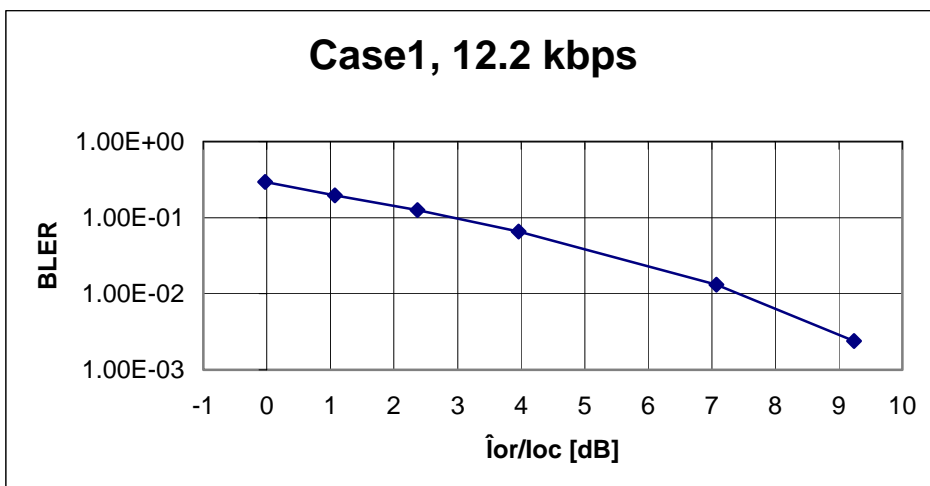

9.7.1.2.1.2 Graphical Presentation of 12.2 kbps service DL Simulation Results

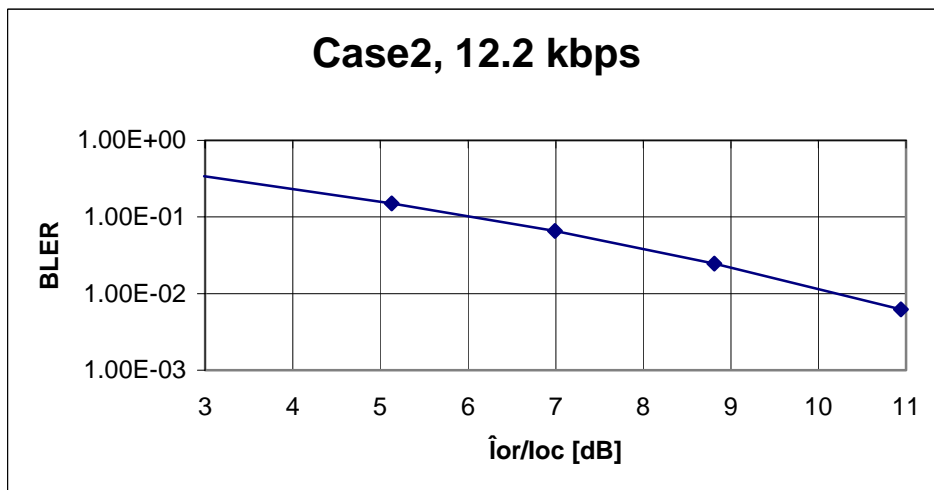
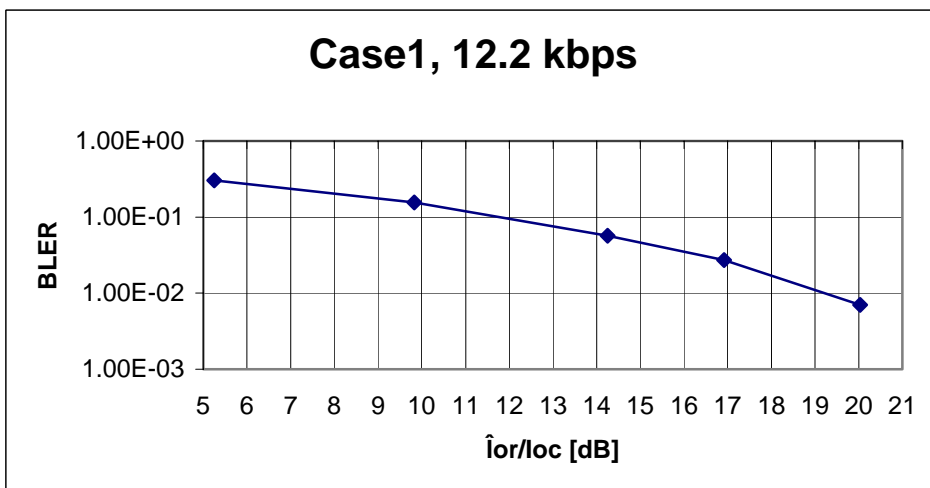
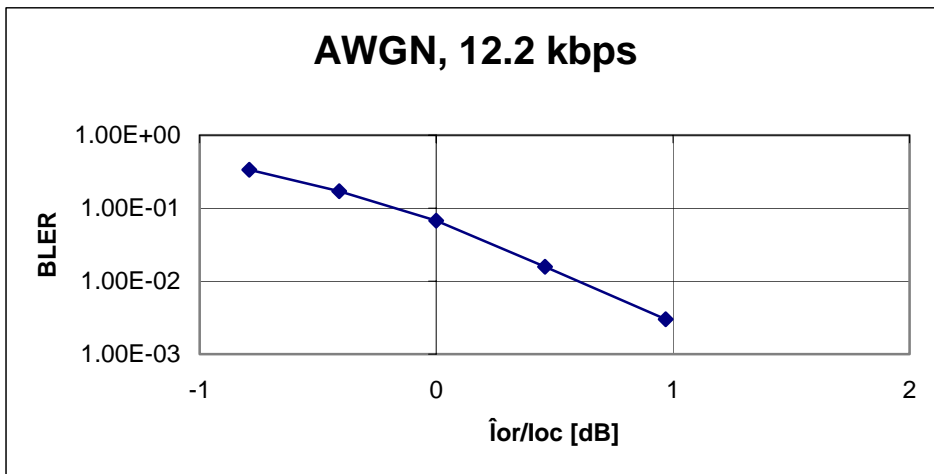

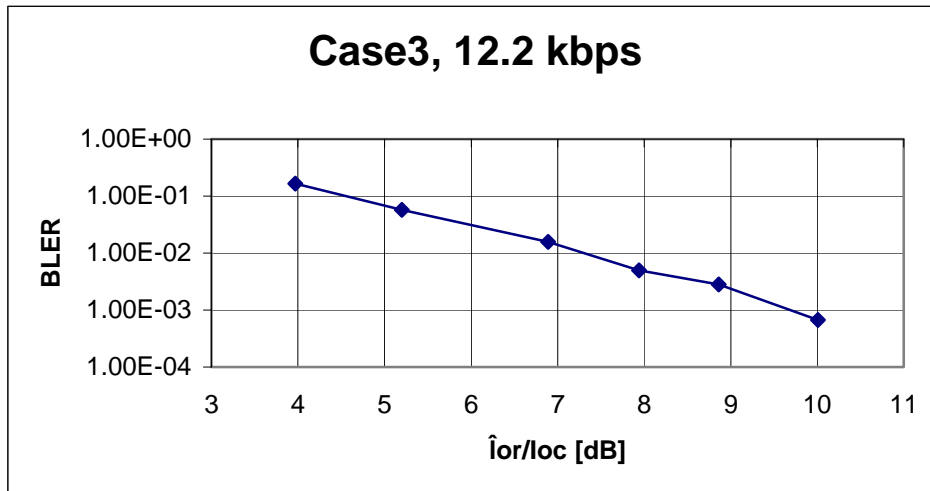

9.7.1.2.2 64kps Service

9.7.1.2.2.1 Graphical Presentation of 64 kbps service UL Simulation Results



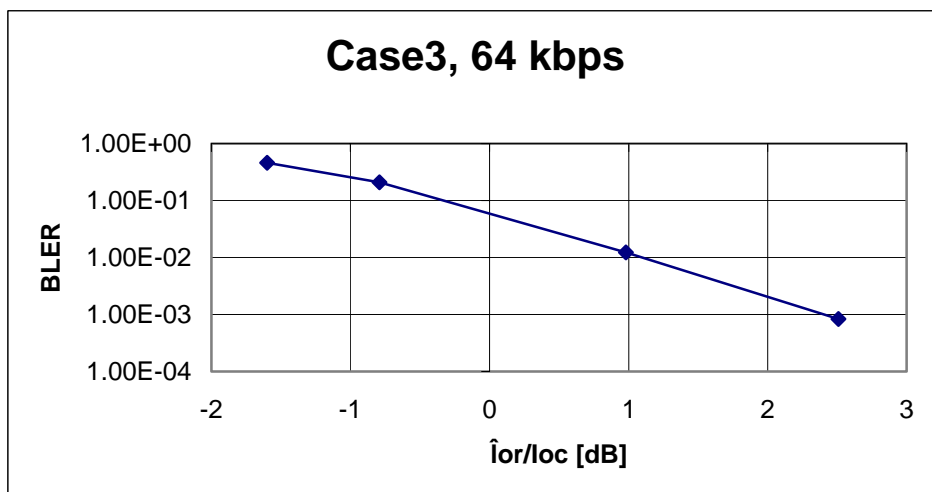
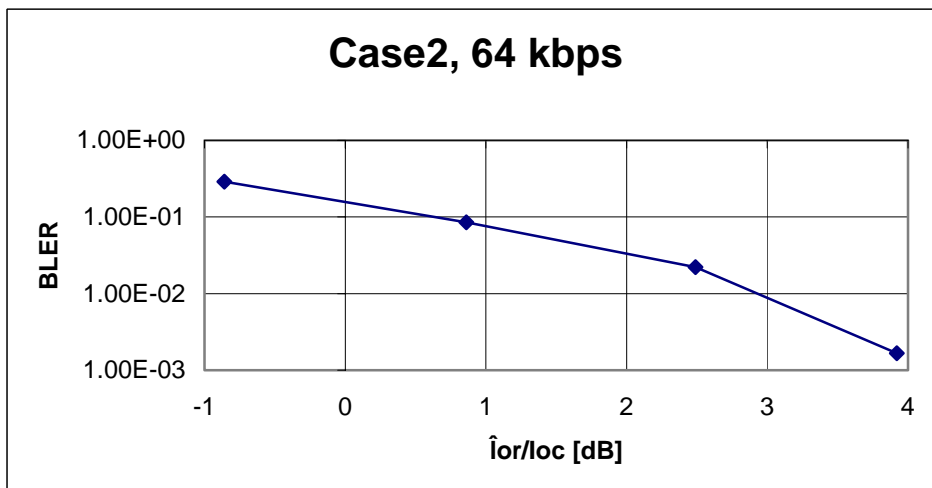
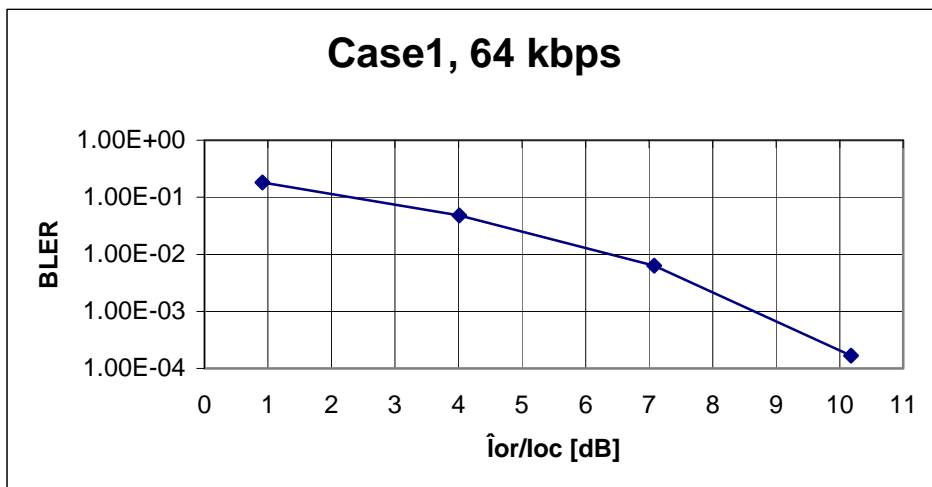

9.7.1.2.2.2 Graphical Presentation of 64 kbps service DL Simulation Results

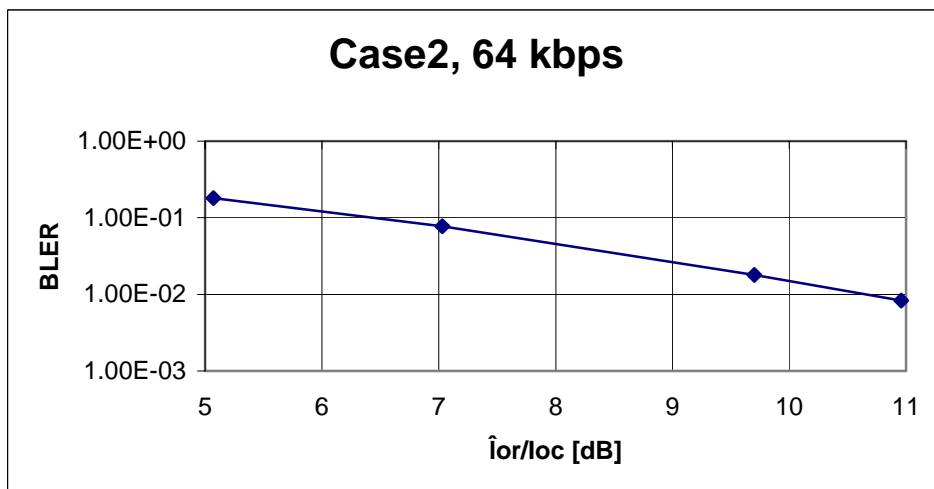
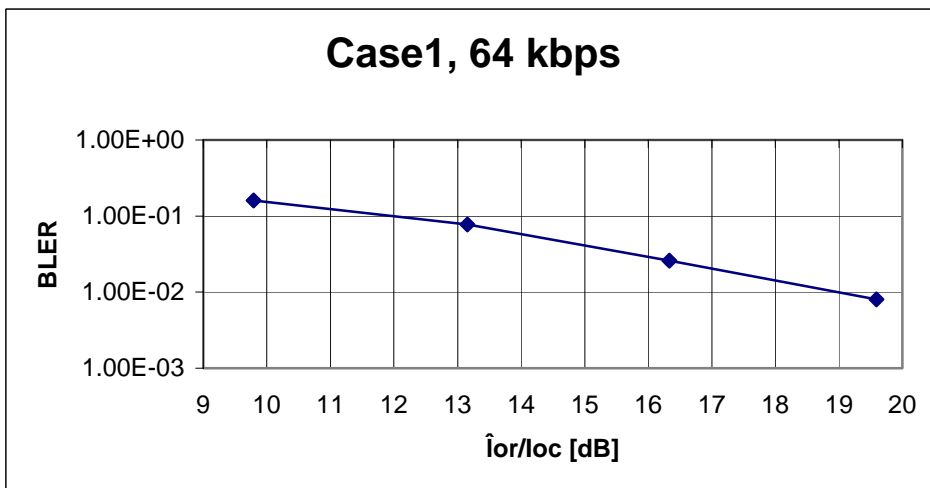
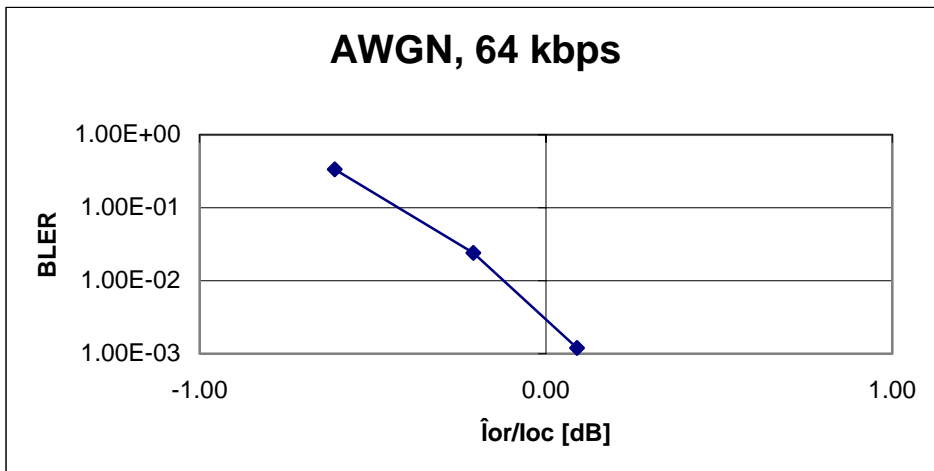

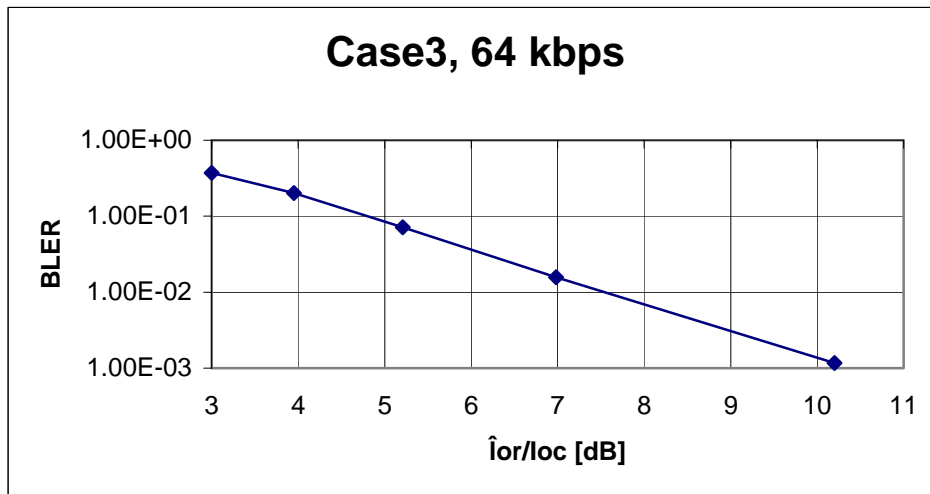

9.7.2 1,28Mcps TDD and FDD link level simulation

Annex: The key physical layer parameters for low chip rate TDD option

Support of :	Difference to high chiprate TDD option	Further details
Support of different radio frame structure	<ol style="list-style-type: none"> 1. Different frame structure to high chiprate TDD option 2. Different basic midamble sequences, maximum channel impulse response is scalable ($W=8, 9, 12, 16, 21, 32, 64$), depending on number of users and environment, including the association between midambles and channelisation codes 3. Use of only one burst type for physical channels except special bursts in DwPTS/UpPTS 4. Support of different timeslot formats due to different number of bits and L1 control signals and midamble length 5. Support of use of 8PSK for special timeslots/all timeslots per cell 6. Beacon function is provided by DwPTS and P-CCPCH 	<p>Segmentation of the radio frame into 2 subframes</p> <p>Each subframe consists of 7 traffic slots (864 chips length) and two special timeslots for synchronisation and initial access which are separated by an extra guard period</p> <p>5. Including TFCI, SS, and TPC coding (8PSK)</p>
Modified Power Control	<ol style="list-style-type: none"> 1. Closed Loop PC in uplink and downlink 2. Open loop PC on the SYNC1 Code while initial access 3. P-CCPCH and DwPTS power can be used as 	<ol style="list-style-type: none"> 1. TPC bits also in downlink 3. transmit power level reported on BCH

	<p>a beacon</p> <p>4.number of TPC symbols can take 2 values</p>	<p>4. none, one symbol, 16/SF TPC symbols per radio frame, number of TPC symbols is always the same like number of SS symbols</p>
Modified RACH procedure	<p>1.Random Access carried out in 2 steps</p>	<p>1. Send SYNC1, Receive FPACH</p> <p>2. Send power controlled, timing advanced PRACH in traffic timeslot (code associated to received FPACH. There is another association between the PRACH and the FACH. These associations are broadcast by the BCH.)</p> <p>Due to the two-step approach a collision most likely happens on the UpPTS. The RACH RUs are virtually collision free.</p> <p>There are no dedicated RACH time slots, the RACH resources share the time slot with dedicated resources, a two step procedure ensures that the actual RACH.</p>
Cell search operation	<p>1.One synchronisation channel only (DwPTS) and different frame duration</p>	<p>Step 1: Search for DwPTS</p> <p>Step 2: Scrambling- and basic midamble code identification</p> <p>Step 3: searches for the head of multi-frame indicated</p> <p>Step 4: Read the BCH</p>
Uplink synchronisation	<p>1.Special Layer1-SS symbols</p> <p>2.Number of used SS symbols can take 2 values</p> <p>3.SS-symbols are transmitted once per</p>	<p>1.SS symbols command an incremental change of timing</p> <p>2.none, one symbol, 16/SF SS symbols per radio frame, number of SS symbols is always the same like number of TPC symbols</p> <p>3.Frequency and step size are configured by</p>

	subframe	UTRAN (“k” and “M” parameters)
Beamforming	Beamforming applies to the dedicated channels and may also be used for some common channels like FPACH	
Physical channels	P-CCPCH and S-CCPCH require two channelisation codes; FPACH is a new physical channel which always uses one channelisation code at SF 16.	
Mapping of transport channels to physical channels	PCH; PICH and FACH can be time multiplexed with the BCH on the P-CCPCH. PCH, PICH and FACH can be time multiplexed on the S-CCPCH. Therefore these transport channels are using two channelisation codes of SF 16.	The PICH carries a different number of PIs than in the high chip rate option, because of the different burst structure.
Measurements	Ranges and accuracy have to be adapted for the low chip rate option.	
Service mapping	Due to the different payload size and subframe segmentation the service mapping for the low chip rate differs from that of the high chip rate option.	

13 History

Document history		
V0.0.0	Apr, 2000	Created based on the WG#11meeting approval
V0.0.1	May 22 nd , 2000	Updated based on the email reflector discussion recommendations till now
V0.0.2	May 24 th , 2000	The RRM in scope is added
V0.0.3	May 25 th , 2000	The RF system scenarios in scope is added
V0.1.0	Jun 23 th , 2000	Revised based on the input tdocs in the WG4#12 meeting in Turku, which have been approved as the start points with brackets for the value.
V0.1.1	Aug 24th,2000	Revised the RF system scenarios section contents, cancel the chapters that wouldn't have been affected by 1.28Mpcs TDD option
V0.2.0	Aug 31th,2000	Revised based on the input tdocs in the WG4 1.28Mpcs TDD option Ad-hoc meeting in London, which have been approved input to the TR25.945.
V0.3.0	Sept 13 th , 2000	Revised based on the input tdocs in the WG4#13 meeting in Turin, which have been approved input to the TR25.945.

Editor information:

Daijun Zhang

CATT/CWTS

Email: Zhangdj@pub.tdsdma.com