

TSG RAN meeting #8
21 – 23 June 2000
Dusseldorf, Germany

Agenda Item: 4.2

Source: ITU Ad Hoc Contact Person

Title: Proposed answer to the liaison from ITU-R WP 8F¹ on the updating of ITU-R M.1457 (IMT.RSPC)

Document for: Discussion & Approval

3GPP TSG RAN thanks ITU-R WP 8F for the liaison on the updating of Recommendation ITU-R M.1457.

3GPP TSG RAN gets this occasion to express its satisfaction for the approval of Recommendation ITU-R M.1457 at the recent Radiocommunication Assembly: this is definitely a major milestone for future wireless communications. 3GPP TSG RAN is grateful to ITU for their work in putting together the cooperative efforts with different external organizations and it is particularly gratified to have participated to the process.

3GPP TSG RAN intends to revise Recommendation ITU-R M.1457 for the year 2000 revision. Relevant material will be provided to ITU-R WP 8F in line with the process outlined in the received liaison statement.

In particular, 3GPP TSG RAN would like to revise section 5.3.1 (IMT-2000 CDMA TDD – Overview of the Radio Interface) in order to reflect the current status of the harmonization initiatives on UTRA TDD. Also sections 5.1.2 (IMT-2000 CDMA Direct Spread – Detailed Specification of the Radio Interface) and 5.3.2 (IMT-2000 CDMA TDD - Detailed Specification of the Radio Interface) will be updated in order to address the most recently approved Deliverables.

A draft revision of section 5.3.1 (IMT-2000 CDMA TDD – Overview of the Radio Interface) is attached as requested by ITU-R WP 8F. Final versions of 5.3.1 and 5.1.2 & 5.3.2 will be submitted to ITU-R WP 8F by October, 13, as requested.

For the future revisions of Recommendation ITU-R M.1457, 3GPP TSG RAN believes that an annual maintenance update interval should be followed, as suggest in the Beijing liaison to SDOs. This would fit the internal 3GPP work plan. The process and relevant time schedule currently proposed for the year 2000 revision should be used also for future revisions.

3GPP TSG RAN looks forward for continuing fruitful cooperation with ITU-R WP 8F.

¹ The liaison from ITU-R WP 8F is contained in RP-000152 discussed at RAN#7

5.3 IMT-2000 CDMA TDD

5.3.1 Overview of the radio interface

5.3.1.1 Introduction

The IMT-2000 radio interface specifications for CDMA TDD technology are developed by a partnership of standards development organizations (SDOs and CWTS)¹. This radio interface is called the Universal Terrestrial Radio Access (UTRA) Time Division Duplex (TDD), including a low and a high chip rate option, and TD-SCDMA.

The UTRA TDD specifications have been developed with the strong objective of harmonisation with the FDD component (see Section 5.1) to achieve maximum commonality. This was achieved by harmonisation of important parameters of the physical layer and a common set of protocols in the higher layers are specified for both FDD and TDD. The ~~TD-SCDMA~~ specifications for the low chip rate option were originally developed in China and introduced by CWTS as TD-SCDMA. TD-SCDMA has significant commonality with UTRA TDD. Within the current specifications, capabilities are included to enable introduction of TD-SCDMA properties into a joint UTRA TDD concept and to allow the on-going process to optimize the integration of the two TDD technologies. The reference sections illustrate the current state of the specification processes⁴.

In the development of this radio interface the core network specifications are based on an evolved GSM-MAP, but the specifications include the necessary capabilities for operation with an evolved ANSI-41 based core network.

The radio access scheme is direct-sequence code division multiple access in combination with time division multiple access. There are two chiprate ~~versions~~ options: UTRA TDD high chip rate option, based on TD-CDMA, with information spread over approximately 5 MHz bandwidth and a chip rate of 3.84 Mcps and UTRA TDD low chip rate option, based on TD-SCDMA, with information spread over approximately 1.6MHz bandwidth and a chiprate of 1.28 Mcps. The radio interface is defined to carry a wide range of services to efficiently support both circuit-switched services (e.g. PSTN- and ISDN-based networks) as well as packet-switched services (e.g. IP-based networks). A flexible radio protocol has been designed where several different services such as speech, data, multimedia can simultaneously be used by a user and multiplexed on a single carrier. The defined radio bearer services provide for both real-time and non-real time services support by employing transparent and/or non-transparent data transport. The quality of service can be adjusted in terms such as delay, bit error ratio, frame error ratio.

5.3.1.2 Radio Access Network Architecture

The overall architecture of the system is shown in Figure 5.22. Note: Macrodiversity (as indicated in the figure) is not necessary in TDD due to the TDMA component, and has not been included in the current specifications.

¹ Currently, these specifications are developed within the Third Generation Partnership Project (3GPP) where the participating SDOs are ARIB, CWTS, ETSI, T1, TTA and TTC.

⁴ It is anticipated that following further An initiatives is currently running in 3GPP with the goal to integrate TD-SCDMA as the “Low-chip-rate TDD option” in Release 2000 of a harmonised joint UTRA TDD solution will be developed in 3GPP.

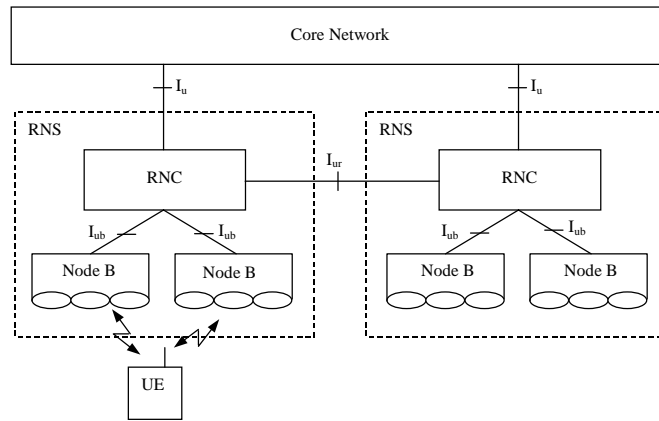

FIGURE 5.22

Radio Access Network Architecture (Cells are indicated by ellipses)

The architecture of this radio interface consists of a set of Radio Network Subsystems (RNS) connected to the Core Network through the I_u interface.

A RNS consists of a Radio Network Controller (RNC) and one or more entities called Node B. Node B are connected to the RNC through the I_{ub} interface. Node B can handle one or more cells.

The RNC is responsible for the handover decisions that require signalling to the User Equipment (UE). Inside the radio interface, the RNCs of the Radio Network Subsystems can be interconnected together through the I_{ur} . The I_u and I_{ur} are logical interfaces. I_{ur} can be conveyed over physical direct connection between RNCs or via any suitable transport network.

Figure 5.23 shows the radio interface protocol architecture for the radio access network. On a general level, the protocol architecture is similar to the current ITU-R protocol architecture as described in ITU-R recommendation M.1035. Layer 2 (L2) is split into two sublayers, Radio Link Control (RLC) and Medium Access Control (MAC). Layer 3 (L3) and RLC are divided into Control (C-) and User (U-) planes.

In the C-plane, L3 is partitioned into sublayers where the lowest sublayer, denoted as Radio Resource Control (RRC), interfaces with L2. The higher layer signalling such as Mobility Management (MM) and Call Control (CC) are assumed to belong to the core network. There are no L3 elements in UTRAN for the U-plane.

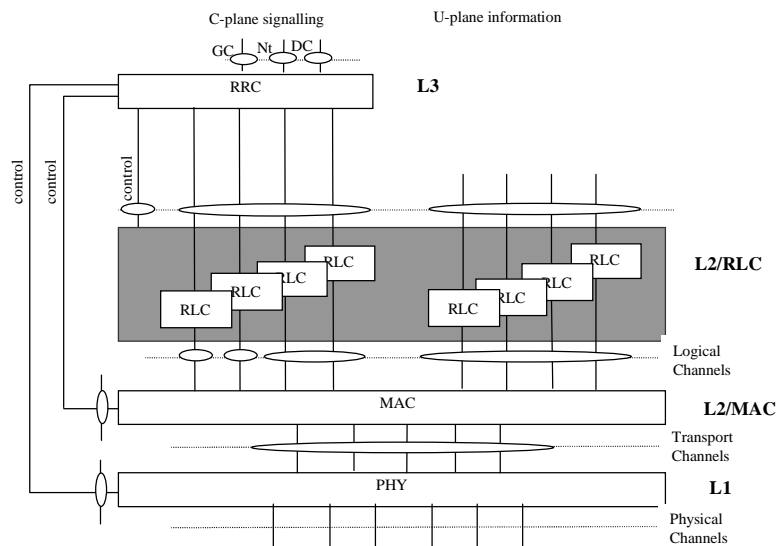

FIGURE 5.23

**Radio interface protocol architecture of the RRC sublayer,
(L2 and L1)**

Each block in Figure 5.23 represents an instance of the respective protocol. Service Access Points (SAP) for peer-to-peer communication are marked with circles at the interface between sublayers. The SAPs between RLC and the MAC sublayer provide the logical channels. The type of information transferred characterises a logical channel. The logical channels are divided into control channels and traffic channels. The different types are not further described in this overview. The SAP between MAC and the physical layer provides the transport channels. A transport channel is characterised by how the information is transferred over the radio interface, see Section 5.3.1.3 for an overview of the types defined. The physical layer generates the physical channels that will be transmitted over the air. The physical channel is defined by carrier frequency, code, time slot and multi-frame information. In the C-plane, the interface between RRC and higher L3 sublayers (CC, MM) is defined by the General Control (GC), Notification (Nt) and Dedicated Control (DC) SAPs. These SAPs are not further discussed in this overview.

Also shown in the figure are connections between RRC and MAC as well as RRC and L1 providing local inter-layer control services (including measurement results). An equivalent control interface exists between RRC and the RLC sublayer. These interfaces allow the RRC to control the configuration of the lower layers. For this purpose separate Control SAPs are defined between RRC and each lower layer (RLC, MAC, and L1).

Figure 5.24 shows the general structure and some additional terminology definitions of the channel formats at the various sublayer interfaces indicated in Figure 5.23. The figure indicates how higher layer Service data Units (SDU) and Protocol Data Units (PDUs) are segmented and multiplexed to transport blocks to be further treated by the physical layer. The transmission chain of the physical layer is described in the next section.

Opportunity Driven Multiple Access (ODMA) operates on relay links between different Relays. These Relays may be represented by either UEs with ODMA capability or ODMA seeds (ODMA equipment permanently located in the network). Relays/Seeds may act as gateways to connect the ODMA equipment to the radio interface. This can be done using either this radio interface or the radio interface in Section 5.1.

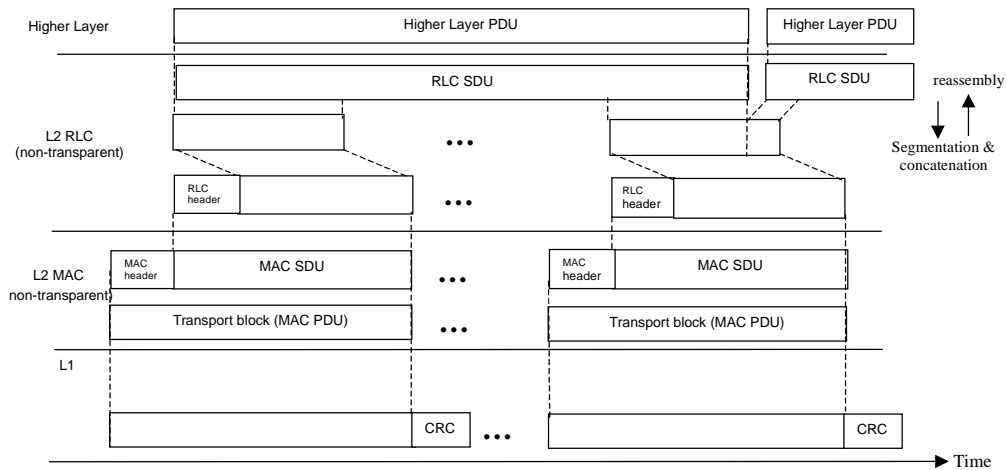

FIGURE 5.24

**Data flow for a service using a non-transparent RLC and non-transparent MAC
(see Sections 5.3.1.4.1-2 for further definitions of the MAC and
RLC services and functionality)**

5.3.1.3 Physical layer

5.3.1.3.1 UTRA TDD (high chip rate option)

5.3.1.3.1.1 Physical layer functionality and building blocks

The physical layer includes the following functionality:

- Error detection on transport channels and indication to higher layers.
- Forward Error Control (FEC) encoding/decoding of transport channels.
- Multiplexing of transport channels and demultiplexing of coded composite transport channels.
- Rate matching (data multiplexed on Dedicated and Shared Channels).
- Mapping of coded composite transport channels on physical channels.
- Power weighting and combining of physical channels.
- Modulation and spreading/demodulation and despreading of physical channels.
- Frequency and time (chip, bit, slot, frame) synchronisation.
- Radio characteristics measurements including Frame Error Rate (FER), Signal-to-Interference (SIR), Interference Power Level etc., and indication to higher layers.
- Closed-loop power control.
- Radio Frequency (RF) processing.
- Support of Timing Advance on uplink channels.

Figure 5.25 gives the physical layer transmission chain for the user plane data, i.e. from the level of transport channels down to the level of physical channel. The figure shows how several transport channels can be multiplexed onto one or more dedicated physical data channels (DPDCH).

The cyclic redundancy check (CRC) provides for error detection of the transport blocks for the particular transport channel. The CRC can take the length zero (no CRC), 8, 16 or 24 bits depending on the service requirements.

The transport block concatenation and code block segmentation functionality performs serial concatenation of those transport blocks that will be sent in one transport time interval and any code block segmentation if necessary.

The types of channel coding defined are convolutional coding, turbo coding and no coding. Real-time services use only FEC encoding while non real-time services uses a combination of FEC and ARQ. The ARQ functionality resides in the RLC layer of Layer 2. The convolutional coding rates are 1/2 or 1/3 while the rate is 1/3 for turbo codes.

The possible interleaving depths are 10, 20, 40 or 80 milliseconds.

The radio frame segmentation performs padding of bits. The rate matching adapts any remaining differences of the bit rate so the number of outgoing bits fit to the available bit rates of the physical channels. Repetition coding and/or puncturing is used for this purpose.

The TrCH multiplexing stage combines transport channels in a serial fashion. This is done every 10 milliseconds. The output of this operation is also called coded composite transport channels.

If several physical channels will be used to transmit the data, the split is made in the physical channel segmentation unit.

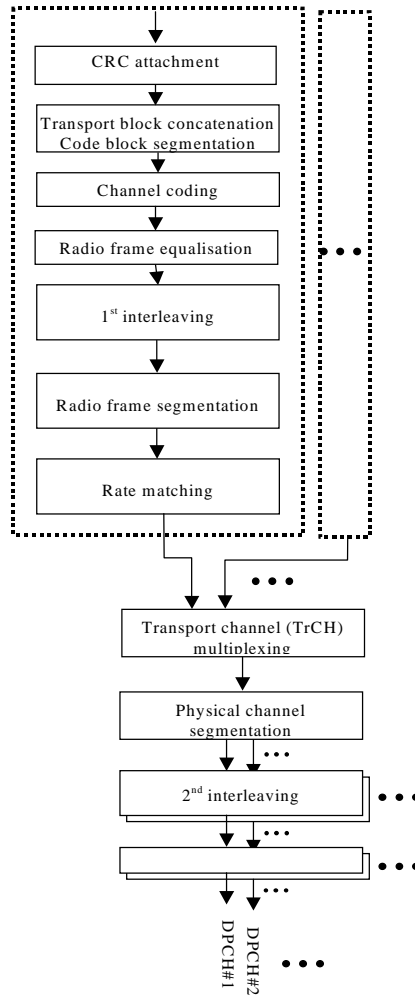

FIGURE 5.25

Transport channel multiplexing structure

5.3.1.3.1.2 Transport channels

The interface to the MAC layer is the transport channels, see Figure 5.23. The transport channels define how and with which type of characteristics the data is transferred by the physical layer. They are categorised into dedicated channels or common channels where many UEs are sharing the latter type. Introducing an information field containing the address then does the address resolution, if needed. The physical channel itself defines a dedicated channel. Thus no specific address is needed for the UE. Table 5.2 summarises the different types of available transport channels.

TABLE 5.2

The defined transport channels

Transport channel	Type and direction	Used for
DCH (Dedicated channel)	Dedicated; uplink and downlink	User or control information to a UE (entire cell or part of cell (lobe-forming))
BCH (Broadcast channel)	Common; downlink	Broadcast system and cell specific information
FACH (Forward access channel)	Common; downlink	Control information when system knows UE location or short user packets to a UE
PCH (Paging channel)	Common; downlink	Control information to UEs when good sleep mode properties are needed, e.g. idle mode operation
RACH (Random access channel)	Common; uplink	Control information or short user packets from an UE
USCH (Uplink shared channel)	Common; Uplink	TDD only. Carries dedicated user data and control information using a shared channel
ODCH (ODMA Dedicated channel)	Dedicated	TDD only. Applicable for ODMA relaying
ORACH (ODMA Random Access Channel)	Common	TDD only. Applicable for ODMA relaying
DSCH (Downlink shared channel)	Common; downlink	Carries dedicated user data and control information using a shared channel.

The random access channel on the uplink is contention-based while the dedicated channel is reservation-based.

5.3.1.3.1.3 Transport channels to Physical channel mapping

The transport channels are mapped onto the physical channels and Figure 5.26 show the different physical channels and summarises the mapping of transport channels onto physical channels. Each physical channel has its tailored slot content. The dedicated channel (DCH) is shown in Section 5.3.1.3.1.4.

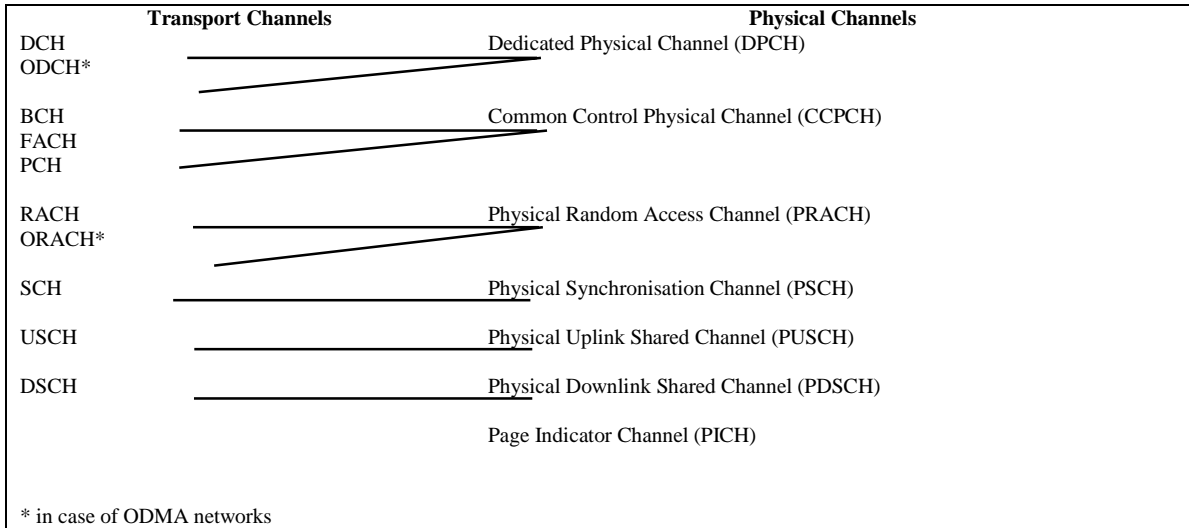

FIGURE 5.26

Transport channels, physical channels and their mapping

5.3.1.3.1.4 Physical frame structure

The basic physical frame rate is 10 milliseconds with 15 slots. Figure 5.27 shows the frame structure.

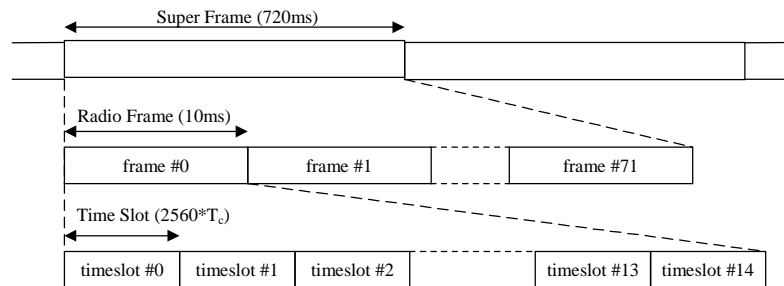

FIGURE 5.27

Basic frame structure – TDD (high chip rate option)

Each 10 ms frame consists of 15 time slots, each allocated to either the uplink or the downlink. With such a flexibility, this radio interface can be adapted to different environments and deployment scenarios. In any configuration at least one time slot has to be allocated for the downlink and at least one time slot has to be allocated for the uplink.

When operating ODMA at least one common timeslot has to be allocated for the ORACH. If large quantities of information have to be transferred between ODMA nodes then it is normal to use at least one timeslot for the ODCH (Figure 5.28).

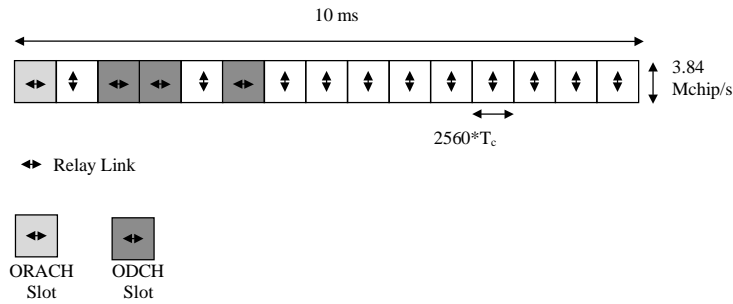

FIGURE 5.28

TDD frame structure example for ODMA operation

Figure 5.29 and Figure 5.30 show the two burst formats stating the content for a slot used by a DCH. The usage of either burst format 1 or 2 is depending on the application for UL or DL and the number of allocated users per timeslot.

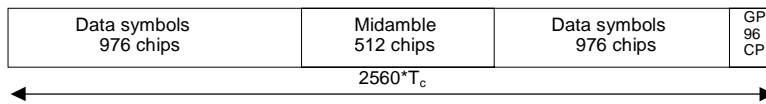

FIGURE 5.29

**Burst structure of the burst type 1
(GP denotes the guard period and CP the chip periods)**

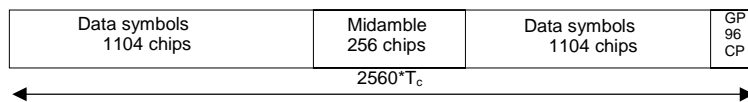

FIGURE 5.30

**Burst structure of the burst type 2
(GP denotes the guard period and CP the chip periods)**

In both cases data bits are QPSK modulated and the resulting symbols are spread with a channelisation code of length 1 to 16. Due to this variable spreading factor, each data part of one burst provides the number of symbols as shown in Table 5.3 below.

TABLE 5.3

Number of data symbols in TDD bursts in high chip rate option

Spreading factor (Q)	Number of symbols (N) per data field in Burst 1	Number of symbols (N) per data field in Burst 2
1	976	1104
2	488	552

4	244	276
8	122	138
16	61	69

Thus, the number of bits per TDD burst in the high chip rate option is four times the number shown in Table 5.3. Usage of multicode and multiple timeslots can be applied.

5.3.1.3.1.5 Spreading, modulation and pulse shaping

Spreading is applied after modulation and before pulse shaping. It consists of two operations. The first is the channelisation operation, which transforms every data symbol into a number of chips, thus increasing the bandwidth of the signal. The number of chips per data symbol is called the Spreading Factor (SF) and is in the range of 1 to 16. The second operation is the scrambling operation, where a scrambling code is applied to the spread signal. This procedure is similar to the radio interface specified in Section 5.1, but it should be noted that the midamble part in TDD bursts (see Figure 5.29 and Figure 5.30) is not spread.

The applied channelisation codes are OVSF-codes (Orthogonal Variable Spreading Factor-codes) that preserve the distinguishability of different users. The applied scrambling code is cell-specific and 128 different scrambling codes are available.

In the Uplink, the applied midamble is user specific and derived from a cell-specific Basic Midamble Sequence. In the Downlink, the applied midamble is either user specific or common for the whole cell. In each case 128 different Basic Midamble sequences are available.

After spreading same pulse-shaping is applied as in FDD Mode, i.e. the filters are root-raised cosine with roll-off $\alpha=0.22$ in the frequency domain.

5.3.1.3.2 TD-SCDMA/UTRA TDD (low chip rate option)

5.3.1.3.2.1 Physical layer functionality and building blocks

The physical layer includes the following functionality:

- FEC encoding/decoding of transport channels
- Macrodiversity distribution/combining and handover execution
- Multiplexing/demultiplexing of transport channels and of coded composite transport channels
- Mapping of coded composite transport channels on physical channels
- Modulation and spreading/demodulation and despreading of physical channels
- Frequency and time (chip, bit, time slot, subframe) synchronization
- Power control
- Random access process
- Dynamic channel allocation (DCA)
- ODMA specific procedures (optional)
- Power weighting and combining of physical channels
- RF processing
- Error detection
- Rate matching (data multiplexed on DCH)
- Radio characteristics measurements including FER, SIR, DOA, timing advance, etc.
- Handover measurements
- Uplink synchronization
- Beamforming for both uplink and downlink (Smart antenna)
- UE location/positioning (Smart antenna)

Figure 5.31 gives the physical layer transmission chain for the user plane data, i.e. from the level of transport channels down to the level of physical channel. The Figure 5.31 shows how several transport channels can be multiplexed onto one or more dedicated physical channels (DPCH). The cyclic redundancy check (CRC) provides for error detection of the transport blocks for the particular transport channel. The CRC can take the length zero (no CRC), 8, 16 or 24 bits depending on the service requirements.

The transport block concatenation and code block segmentation functionality performs serial concatenation of those transport blocks that will be sent in one transport time interval and any code block segmentation if necessary.

The types of channel coding defined are convolutional coding, turbo coding and no coding. Real-time services use only FEC encoding while non real-time services uses a combination of FEC and ARQ. The ARQ functionality resides in the RLC layer of Layer 2. The convolutional coding rates are 1/2 or 1/3 while the rate is 1/3 for turbo codes. The possible interleaving depths are 10, 20, 40 or 80 milliseconds.

The radio frame equalization performs padding of bits. The rate matching adapts any remaining differences of the bit rate so the number of outgoing bits fit to the available bit rates of the physical channels. Repetition coding and/or puncturing is used for this purpose.

The TrCH multiplexing stage combines transport channels in a serial fashion. This is done every 10 milliseconds. The output of this operation is also called coded composite transport channels.

If several physical channels will be used to transmit the data, the split is made in the physical channel segmentation unit.

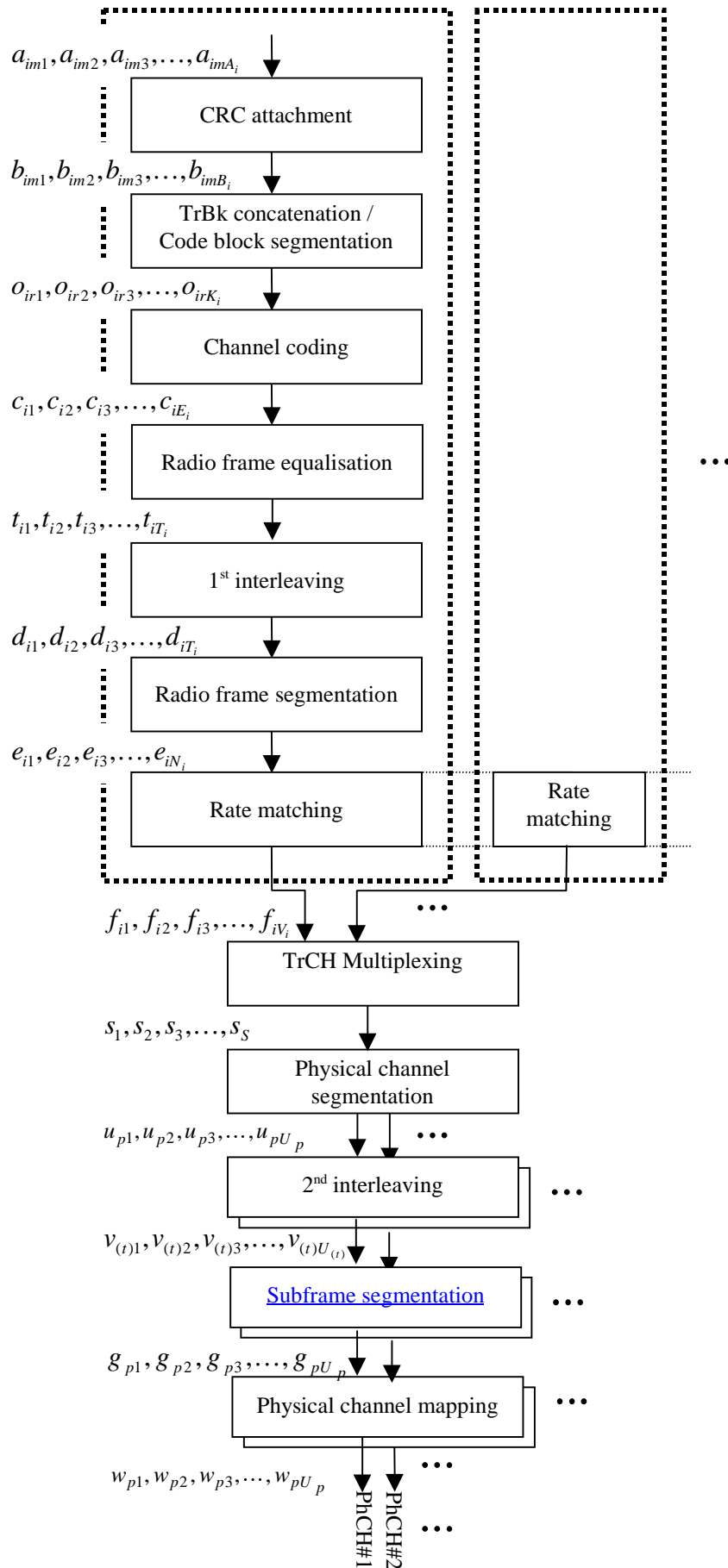

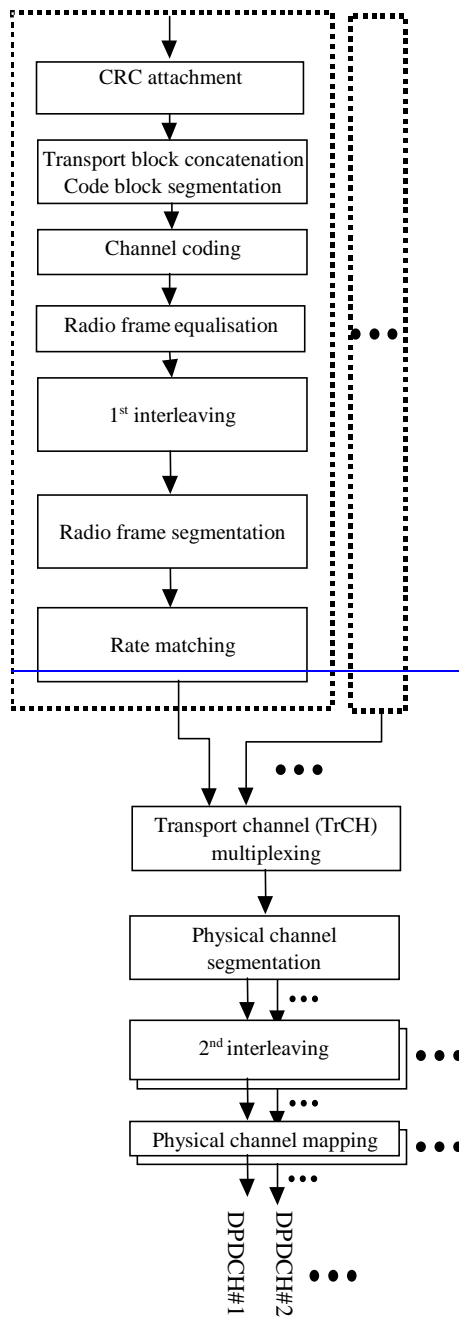

FIGURE 5.31

Transport channel multiplexing structure

5.3.1.3.2.2 Transport channels

The interface to the MAC layer is the transport channels, see Figure 5.22. The transport channels define how and with which type of characteristics the data is transferred by the physical layer. They are categorised into dedicated channels or common channels where many UEs are sharing the latter type. Introducing an information field containing the address then does the address resolution, if needed. The physical channel itself defines a dedicated channel. Thus no specific address is needed for the UE. Table 5.4 summarises the different types of available transport channels.

TABLE 5.4

The defined transport channels

Transport channel	Type and direction	Used for
DCH (Dedicated channel)	Dedicated; uplink and downlink	User or control information to a UE (entire cell or part of cell (lobe-forming))
BCH (Broadcast channel)	Common; downlink	Broadcast system and cell specific information
FACH (Forward access channel)	Common; downlink	Control information when system knows UE location or short user packets to a UE
PCH (Paging channel)	Common; downlink	Control information to UEs when good sleep mode properties are needed, e.g. idle mode operation
RACH (Random access channel)	Common; uplink	Control information or short user packets from an UE
SCH (Pilot and Synchronisation channel)	Common; uplink and downlink	Transmit uplink/downlink pilot sequence and synchronization codes
ODCH* (ODMA Dedicated channel)	Dedicated	Applicable for ODMA relaying
ORACH* (ODMA Random Access Channel)	Common	Applicable for ODMA relaying
DSCH (Downlink shared channel)	Common; downlink	Carries dedicated user data and control information using a shared channel.
USCH (Uplink shared channel)	Common; Uplink	Carries dedicated user data and control information using a shared channel
*: item which is an option		

The random access channel on the uplink is contention-based while the dedicated channel is reservation-based.

5.3.1.3.2.3 Transport channels to physical channel mapping

The transport channels are mapped onto the physical channels, and Figure 5.32 shows the different physical channels and summarises the mapping of transport channels onto physical channels. Each physical channel has its tailored slot content. The dedicated channel (DCH) is shown in section 5.3.1.3.2.4.

<u>Transport channels</u>	<u>Physical channels</u>
DCH	Dedicated Physical Channel (DPCH)
BCH	Primary Common Control Physical Channels (P-CCPCH)
PCH	Primary Common Control Physical Channels (P-CCPCH) Secondary Common Control Physical Channels(S-CCPCH)
FACH	Primary Common Control Physical Channels (P-CCPCH) Secondary Common Control Physical Channels(S-CCPCH)
RACH	Physical Random Access Channel (PRACH)
USCH	Physical Uplink Shared Channel (PUSCH)
DSCH	Physical Downlink Shared Channel (PDSCH)
	Down link Pilot Time Slot (DwPTS)
	Up link Pilot Time Slot (UpPTS)
	FPACH

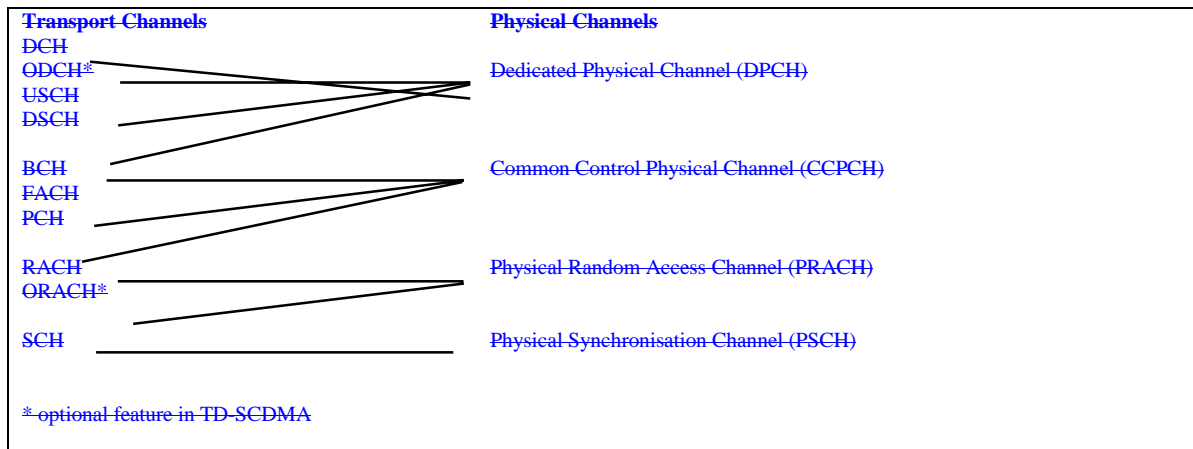

FIGURE 5.32

Transport channel, physical channel and their mapping

5.3.1.3.2.4 Frame structure

Physical channels take four-layer structure of super-frames, radio frames, sub-frames and time slots/codes as shown in Figure 5.33. One super frame has the length of 720ms, which is composed by 72 radio frames. The radio frame has a duration of 10 ms and is subdivided into 2 sub-frames of 5ms each, and each subframe is then subdivided into 7 main time slots (TS) of 675 μ s duration each and 3 special time slots: DwPTS (downlink pilot), G (guard period) and UpPTS (uplink pilot).

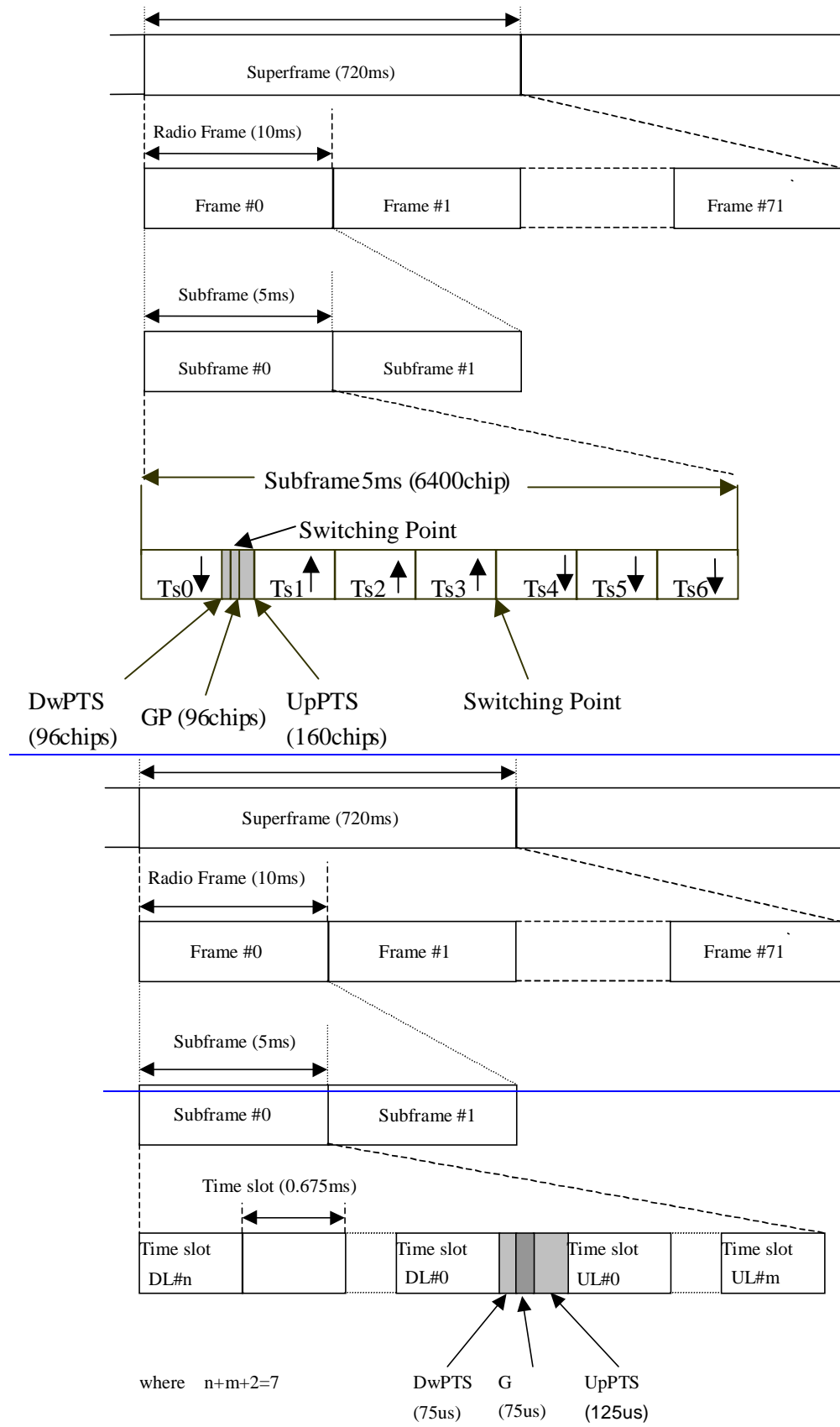

FIGURE 5.33

Frame and burst structure

When operating ODMA at least one common timeslot has to be allocated for the ORACH. If large quantities of information have to be transferred between ODMA nodes then it is normal to use at least one timeslot for the ODCH (Figure 5.34).

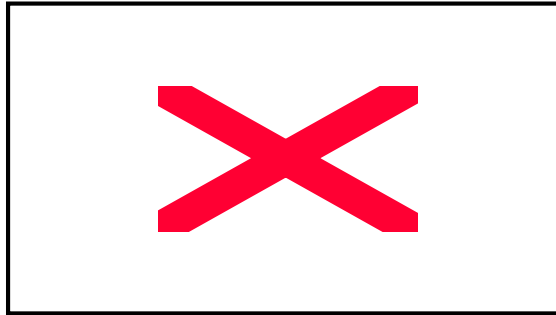

FIGURE 5.34

Frame structure for ODMA operation

The burst structure is shown in Figure 5.35. The burst type consist of two data symbol fields, a midamble of 144 chips and a guard period of 16 chips. The data fields of the burst type are 704 chips long. Data bits in the burst are QPSK modulated and are spread by the spreading factor of 1 to 16. The guard period for the burst type is 16 chips period long. 8PSK modulation may optionally be applied.



FIGURE 5.35

Burst structure

The corresponding number of symbols depends on the spreading factor as indicated in Table 5.5.

TABLE 5.5

Number of data symbols in one burst with different SF

Spreading factor (Q)	Number of symbols (N) per data field in Burst
1	352
2	176
4	88
8	44
16	22

5.3.1.3.2.5 Spreading, modulation and pulse shaping

Spreading is applied after modulation and before pulse shaping. It consists of two operations. The first is the channelisation operation, which transforms every data symbol into a number of chips, thus increasing the bandwidth of the signal. The number of chips per data symbol is called the Spreading Factor (SF) and is in the range of 1 to 16. The second operation is the scrambling operation, where a scrambling code is applied to the spread signal. It should be noted that the midamble part in TDD bursts is not spread.

The applied channelisation codes are OVVSF-codes (Orthogonal Variable Spreading Factor-codes) that preserve the distinguishability of different users. The applied scrambling code is cell-specific. In the Uplink, the applied midamble is user specific and derived from a cell-specific Basic Midamble Sequence. In the downlink, the applied midamble is either user specific or common for the whole cell. After spreading, pulse-shaping is applied, i.e. the filters are root-raised cosine with roll-off $\alpha=0.22$ in the frequency domain.

5.3.1.3.2.6 Transmission and reception

The frequency bands assumed for operation are unpaired frequency bands at 2GHz. Also system can work in other frequency bands available. Several Tx power classes for UE are being defined currently.

5.3.1.4 Layer 2

5.3.1.4.1 Medium Access Control (MAC) layer

The MAC sublayer is responsible for the handling of the data streams coming from the RLC and RRC sublayers. It provides an unacknowledged transfer mode service to the upper layers. The interface to the RLC sublayer is through logical channel service access points. It also reallocates radio resources on request by the RRC sublayer as well as provides measurements to the upper layers. The logical channels are divided into control channels and traffic channels. Thus, the functionality handles issues like:

- Mapping of the different logical channels to the appropriate transport channels and selection of appropriate transport format for the transport channels based on the instantaneous source bit rate. It also performs the multiplexing /demultiplexing of the PDUs to/from transport blocks which are thereafter further treated by the physical layer;
- performs dynamic switching between common and dedicated transport channels based on information from the RRC sublayer;
- handles priority issues for services to one UE according to information from higher layers and physical layer (e.g. available transmit power level) as well as priority handling between UEs by means of dynamic scheduling in order to increase spectrum efficiency;
- monitor traffic volume that can be used by the RRC sublayer;

Figure 5.36 shows the possibilities of mapping the logical channel DTCH (dedicated traffic channel) onto transport channels. There are possibilities to map onto shared transport channels as well as dedicated transport channels. The choice of mapping could be determined on e.g. amount of traffic a user creates.

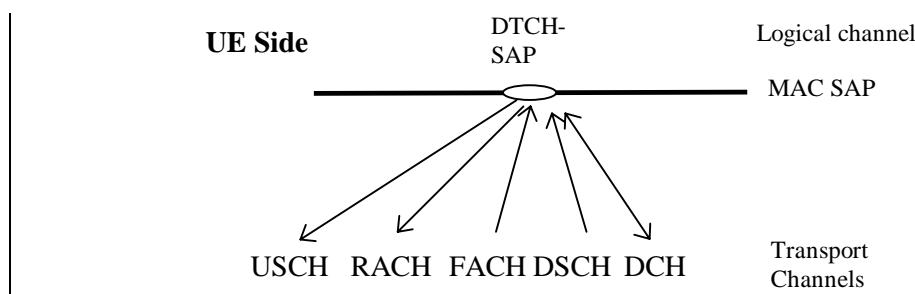

FIGURE 5.36

The possible transport channel mappings of the dedicated traffic channel (DTCH)
(The arrows shows the direction of the channel (UE side); the directions are reversed from the network side)

5.3.1.4.2 Radio Link Control (RLC) sublayer

The RLC sublayer provides three different types of data transfer modes:

- **Transparent data transfer.** This service transmits higher layer PDUs without adding any protocol information, possibly including segmentation/reassemble functionality.

- **Unacknowledged data transfer.** This service transmits higher layer PDUs without guaranteeing delivery to the peer entity. The unacknowledged data transfer mode has the following characteristics:
 - Detection of erroneous data: The RLC sublayer shall deliver only those SDUs to the receiving higher layer that are free of transmission errors by using the sequence-number check function.
 - Unique delivery: The RLC sublayer shall deliver each SDU only once to the receiving upper layer using duplication detection function.
 - Immediate delivery: The receiving RLC sublayer entity shall deliver a SDU to the higher layer receiving entity as soon as it arrives at the receiver.
- **Acknowledged data transfer.** This service transmits higher layer PDUs and guarantees delivery to the peer entity. In case RLC is unable to deliver the data correctly, the user of RLC at the transmitting side is notified. For this service, both in-sequence and out-of-sequence delivery are supported. In many cases a higher layer protocol can restore the order of its PDUs. As long as the out-of-sequence properties of the lower layer are known and controlled (i.e. the higher layer protocol will not immediately request retransmission of a missing PDU) allowing out-of-sequence delivery can save memory space in the receiving RLC. The acknowledged data transfer mode has the following characteristics:
 - Error-free delivery: Error-free delivery is ensured by means of retransmission. The receiving RLC entity delivers only error-free SDUs to the higher layer.
 - Unique delivery: The RLC sublayer shall deliver each SDU only once to the receiving upper layer using duplication detection function.
 - In-sequence delivery: RLC sublayer shall provide support for in-order delivery of SDUs, i.e., RLC sublayer should deliver SDUs to the receiving higher layer entity in the same order as the transmitting higher layer entity submits them to the RLC sublayer.
 - Out-of-sequence delivery: Alternatively to in-sequence delivery, it shall also be possible to allow that the receiving RLC entity delivers SDUs to higher layer in different order than submitted to RLC sublayer at the transmitting side.

It also provides for RLC connection establishment/release. As well as QoS setting and notification to higher layers in case of unrecoverable errors.

An example of the data flow for non-transparent (acknowledged/unacknowledged) data transfer is shown in Figure 5.24.

5.3.1.5 Layer 3 (Radio resource control sublayer)

The Radio Resource Control (RRC) sublayer handles the control plane signalling of Layer 3 between the UEs and the radio access network. In addition to the relation with the upper layers (such as core network) the following main functions are performed:

- **Broadcast of information provided by the non-access stratum (Core Network).** The RRC layer performs system information broadcasting from the network to all UEs. The system information is normally repeated on a regular basis. This function supports broadcast of higher
- layer (above RRC) information. This information may be cell specific or not. As an example RRC may broadcast Core Network location service area information related to some specific cells.

- **Broadcast of information related to the access stratum.** The RRC layer performs system information broadcasting from the network to all UEs. This function supports broadcast of typically cell-specific information.
- **Establishment, maintenance and release of an RRC connection between the UE and this radio interface.** The establishment of an RRC connection is initiated by a request from higher layers at the UE side to establish the first Signalling Connection for the UE. The establishment of an RRC connection includes an optional cell re-selection, an admission control, and a layer 2 signalling link establishment.
- **Establishment, reconfiguration and release of Radio Access Bearers.** The RRC layer will, on request from higher layers, perform the establishment, reconfiguration and release of radio access bearers in the user plane. A number of radio access bearers can be established to an UE at the same time. At establishment and reconfiguration, the RRC layer performs admission control and selects parameters describing the radio access bearer processing in layer 2 and layer 1, based on information from higher layers.
- **Assignment, reconfiguration and release of radio resources for the RRC connection.** The RRC layer handles the assignment of radio resources (e.g. codes and, for TDD only, timeslots) needed for the RRC connection including needs from both the control and user plane. The RRC layer may reconfigure radio resources during an established RRC connection. This function includes coordination of the radio resource allocation between multiple radio bearers related to the same RRC connection. RRC controls the radio resources in the uplink and downlink such that UE and the radio access network can communicate using unbalanced radio resources (asymmetric uplink and downlink). RRC signals to the UE to indicate resource allocations for purposes of handover to GSM or other radio systems.
- **RRC connection mobility functions.** The RRC layer performs evaluation, decision and execution related to RRC connection mobility during an established RRC connection, such as handover, preparation of handover to GSM or other systems, cell re-selection and cell/paging area update procedures, based on e.g. measurements done by the UE.
- **Paging/notification.** The RRC layer can broadcast paging information from the network to selected UEs. The RRC layer can also initiate paging during an established RRC connection.
- **Control of requested QoS.** This function ensures that the QoS requested for the radio access bearers can be met. This includes the allocation of a sufficient number of radio resources.
- **UE measurement reporting and control of the reporting.** The measurements performed by the UE are controlled by the RRC layer, in terms of what to measure, when to measure and how to report, including both this radio interface and other systems. The RRC layer also performs the reporting of the measurements from the UE to the network.
- **Outer loop power control.*** The RRC layer controls setting of the target of the closed loop power control.
- **Control of ciphering.** The RRC layer provides procedures for setting of ciphering (on/off) between the UE and the radio access network.

- **Initial cell selection and re-selection in idle mode.** Selection of the most suitable cell based on idle mode measurements and cell selection criteria.
- **Arbitration of the radio resource allocation between the cells.** This function shall ensure optimal performance of the overall radio access network capacity.
- **Broadcast of ODMA relay node neighbour information.** The RRC layer performs probe information broadcasting to allow ODMA routing information to be collected.
- **Collating ODMA neighbour list and gradient information.** The ODMA relay node neighbour lists and their respective gradient information maintained by the RRC.
- **Maintenance of number of ODMA relay node neighbours.** The RRC will adjust the broadcast powers used for probing messages to maintain the desired number of neighbours.
- **Establishment, maintenance and release of a route between ODMA relay nodes.** The establishment of an ODMA route and RRC connection based upon the routing algorithm.
- **Interworking between the Gateway ODMA relay node and the radio access network.** The RRC layer will control the interworking communication link between the Gateway ODMA relay node and the radio access network.
- **Contention resolution.** The RRC handles reallocations and releases of radio resources in case of collisions indicated by lower layers.
- **Slow DCA.** Allocation of preferred radio resources based on long-term decision criteria.
- **Timing advance control.*** The RRC controls the operation of timing advance.
- **Active UE positioning **** This RRC layer will determine the position of each active UE according to the received information from physical layer.

* ~~UTRA TDD low chip rate option TD-SCDMA~~ does not support this function.

**UTRA TDD high chip rate option does not support this function.

5.3.1.6 Summary of major technical parameters

Parameter	“Value”	Reference to Section 5.3.2
Multiple access technique and duplexing scheme	Multiple Access: TDMA/CDMA Duplexing: TDD	5.3.2.1.1
Chip rate	3.84 Mcps 1.28 Mcps	5.3.2.1.4
Frame length and structure	Frame length: 10 ms 15 slots per frame, each 666.666 µs Sub-frame length: 5 ms 7 main slots per sub-frame, each 675 µs	5.3.2.1.2
Occupied bandwidth	Less than 5 MHz Less than 1.6MHz	5.3.2.4.1 5.3.2.4.3
Adjacent Channel Leakage power ratio (transmitter side)	UE: (UE Power Class: + 21 dBm) ACLR (5 MHz) = 33 Db ACLR (10 MHz) = 43 dB BS: ACLR (5 MHz) = 45 dB ACLR (10 MHz) = 55 dB UE: (UE Power Class: + 21 dBm) ACLR (1.6 MHz) = 33 dB ACLR (3.2 MHz) = 43 dB BS: ACLR (1.6 MHz) = 40 dB	5.3.2.4.1 5.3.2.4.3.

	ACLR (3.2 MHz) = 50 dB	
Adjacent channel selectivity (receiver side)	UE: ACS = 33 dB BS: ACS = 45 dB	5.3.2.4.1 5.3.2.4.3
Random access mechanism	RACH burst on dedicated Uplink slot(s)	5.3.2.1.2, 5.3.2.1.5
Channel estimation	Midambles are used for channel estimation	5.3.2.1.2
Inter base station asynchronous/synchronous operation	Synchronous operation	5.3.2.1.5 5.3.2.4.3