

---

# **TS 25.104 v2.4.1 (1999-10)**

---

**3<sup>rd</sup> Generation Partnership Project (3GPP)  
Technical Specification Group (TSG) RAN WG4  
UTRA (BS) FDD; Radio transmission and Reception**





Reference

---

<Workitem>

Keywords

---

<keyword[, keyword]>

**3GPP**

Postal address

---

Office address

---

Internet

---

secretariat@3gpp.org  
Individual copies of this deliverable  
can be downloaded from  
<http://www.3gpp.org>

All rights reserved

---

**Copyright Notification**

---

Reproduction is only permitted for the purpose of standardisation work undertaken within xxxx.  
The copyright and the foregoing restrictions extend to reproduction in all media.

xxxxxx...xxx

**3GPP**

---

# Contents

<b>INTELLECTUAL PROPERTY RIGHTS</b> .....	<b>7</b>
<b>FOREWORD</b> .....	<b>7</b>
<b>1 SCOPE</b> .....	<b>7</b>
<b>2 REFERENCES</b> .....	<b>7</b>
<b>3 DEFINITIONS, SYMBOLS AND ABBREVIATIONS</b> .....	<b>8</b>
3.1 DEFINITIONS .....	8
3.2 SYMBOLS .....	8
3.3 ABBREVIATIONS .....	8
<b>4 GENERAL</b> .....	<b>9</b>
4.1 MEASUREMENT UNCERTAINTY .....	9
4.2 BASE STATION CLASSES .....	9
<b>5 FREQUENCY BANDS AND CHANNEL ARRANGEMENT</b> .....	<b>10</b>
5.1 GENERAL .....	10
5.2 FREQUENCY BANDS.....	10
5.3 TX–RX FREQUENCY SEPARATION .....	10
5.4 CHANNEL ARRANGEMENT .....	10
5.4.1 Channel spacing .....	10
5.4.2 Channel raster .....	10
5.4.3 Channel number.....	10
<b>6 TRANSMITTER CHARACTERISTICS</b> .....	<b>11</b>
6.1 GENERAL.....	11
6.2 BASE STATION OUTPUT POWER.....	11
6.2.1 Base station maximum output power .....	11
6.2.1.1 Minimum requirement.....	11
6.3 FREQUENCY STABILITY .....	11
6.3.1 Minimum requirement.....	11
6.4 OUTPUT POWER DYNAMICS.....	11
6.4.1 Inner loop power control in the downlink.....	11
6.4.1.1 Power control steps .....	11
6.4.1.1.1 Minimum requirement.....	11
6.4.2 Power control dynamic range .....	12
6.4.2.1 Minimum requirements .....	12
6.4.3 Total power dynamic range.....	12
6.4.3.1 Minimum requirement.....	12
6.4.4 Power control cycles per second .....	12
6.4.5 Primary CPICH power.....	12
6.4.5.1 Requirement.....	13
6.6 OUTPUT RF SPECTRUM EMISSIONS .....	13
6.6.1 Occupied bandwidth .....	13
6.6.2 Out of band emission .....	13
6.6.2.1 Spectrum emission mask .....	13
6.6.2.2 Adjacent Channel Leakage power Ratio (ACLR) .....	14
6.6.2.2.1 Minimum requirement.....	14
6.6.2.3 Protection outside a licensee’s frequency block.....	14
6.6.2.3.1 Minimum requirement.....	14
6.6.3 Spurious emissions.....	15
6.6.3.1 Mandatory Requirements.....	15
6.6.3.1.1 Spurious emissions (Category A) .....	15

6.6.3.1.1.1	Minimum Requirement .....	15
6.6.3.1.2	Spurious emissions (Category B) .....	15
6.6.3.1.2.1	Minimum Requirement .....	16
6.6.3.2	Protection of the BS receiver .....	16
6.6.3.2.1	Minimum Requirement.....	16
6.6.3.3	Co-existence with GSM 900.....	16
6.6.3.3.1	Operation in the same geographic area.....	16
6.6.3.3.1.1	Minimum Requirement .....	16
6.6.3.3.2	Co-located base stations.....	17
6.6.3.3.2.1	Minimum Requirement .....	17
6.6.3.4	Co-existence with DCS 1800.....	17
6.6.3.4.1	Operation in the same geographic area.....	17
6.6.3.4.1.1	Minimum Requirement .....	17
6.6.3.4.2	Co-located base stations.....	17
6.6.3.4.2.1	Minimum Requirement .....	17
6.6.3.5	Co-existence with PHS.....	18
6.6.3.5.1	Minimum Requirement.....	18
6.6.3.6	Co-existence with services in adjacent frequency bands .....	18
6.6.3.6.1	Minimum requirement.....	18
6.7	TRANSMIT INTERMODULATION .....	18
6.7.1	<i>Minimum requirement</i> .....	18
6.8	TRANSMIT MODULATION.....	18
6.8.1	<i>Transmit pulse shape filter</i> .....	18
6.8.2	<i>Modulation Accuracy</i> .....	19
6.8.2.1	Minimum requirement.....	19
6.8.3	<i>Peak code Domain error</i> .....	19
6.8.3.1	Minimum requirement.....	19
<b>7</b>	<b>RECEIVER CHARACTERISTICS.....</b>	<b>20</b>
7.1	GENERAL.....	20
7.2	REFERENCE SENSITIVITY LEVEL .....	20
7.2.1	<i>Minimum requirement</i> .....	20
7.2.2	<i>Maximum Frequency Deviation for Receiver Performance</i> .....	20
7.3	DYNAMIC RANGE.....	20
7.4	ADJACENT CHANNEL SELECTIVITY (ACS).....	20
7.4.1	<i>Minimum requirement</i> .....	20
7.5	BLOCKING CHARACTERISTICS.....	21
7.5.1	<i>Minimum requirement</i> .....	21
7.6	INTERMODULATION CHARACTERISTICS .....	21
7.6.1	<i>Minimum requirerment</i> .....	21
7.7	SPURIOUS EMISSIONS.....	21
7.7.1	<i>Minimum requirement</i> .....	22
<b>8</b>	<b>PERFORMANCE REQUIREMENT .....</b>	<b>23</b>
8.1	GENERAL.....	23
8.2	DEMODULATION IN STATIC PROPAGATION CONDITIONS.....	23
8.2.1	<i>Demodulation of DCH</i> .....	23
8.2.1.1	Minimum requirement .....	23
8.3	DEMODULATION OF DCH IN MULTIPATH FADING CONDITIONS .....	23
8.3.1	<i>Multipath fading Case 1</i> .....	23
8.3.1.1	Minimum requirement .....	24
8.3.2	<i>Multipath fading Case 2</i> .....	24
8.3.2.1	Minimum requirement .....	24
8.3.3	<i>Multipath fading Case 3</i> .....	24
8.3.3.1	Minimum requirement .....	24
8.4	DEMODULATION OF DCH IN MOVING PROPAGATION CONDITIONS.....	25
8.4.1	<i>Minimum requirement</i> .....	25
8.5	DEMODULATION OF DCH IN BIRTH/DEATH PROPAGATION CONDITIONS .....	25
8.5.1	<i>Minimum requirement</i> .....	25
<b>ANNEX A (NORMATIVE): MEASUREMENT CHANNELS .....</b>	<b>26</b>	
A.1	SUMMARY OF UL REFERENCE MEASUREMENT CHANNELS.....	26

A.2	UL REFERENCE MEASUREMENT CHANNEL FOR 12.2 KBPS .....	27
A.3	UL REFERENCE MEASUREMENT CHANNEL FOR 64 KBPS .....	28
A.4	UL REFERENCE MEASUREMENT CHANNEL FOR 144 KBPS .....	29
A.5	UL REFERENCE MEASUREMENT CHANNEL FOR 384 KBPS .....	30
A.6	UL REFERENCE MEASUREMENT CHANNEL FOR 2048 KBPS .....	31
<b>ANNEX B (NORMATIVE): PROPAGATION CONDITIONS .....</b>		<b>32</b>
B.1	<i>Static propagation condition</i> .....	32
B.2	<i>Multi-path fading propagation conditions</i> .....	32
B.3	<i>Moving propagation conditions</i> .....	32
B.4	<i>Birth-Death propagation conditions</i> .....	33
<b>ANNEX C (INFORMATIVE): OPEN ITEMS .....</b>		<b>34</b>
<b>HISTORY .....</b>		<b>35</b>

---

## Intellectual Property Rights

IPRs essential or potentially essential to the present document may have been declared to ETSI. The information pertaining to these essential IPRs, if any, is publicly available for **ETSI members and non-members**, and can be found in ETR 314: "*Intellectual Property Rights (IPRs); Essential, or potentially Essential, IPRs notified to ETSI in respect of ETSI standards*", which is available **free of charge** from the ETSI Secretariat. Latest updates are available on the ETSI Web server (<http://www.etsi.fr/ipr>).

Pursuant to the ETSI Interim IPR Policy, no investigation, including IPR searches, has been carried out by ETSI. No guarantee can be given as to the existence of other IPRs not referenced in ETR 314 (or the updates on <http://www.etsi.fr/ipr>) which are, or may be, or may become, essential to the present document.

---

## Foreword

This Technical Specification has been produced by the 3GPP.

The contents of the present document are subject to continuing work within the TSG and may change following formal TSG approval. Should the TSG modify the contents of this TS, it will be re-released by the TSG with an identifying change of release date and an increase in version number as follows:

Version 3.y.z

where:

- x the first digit:
  - 1 presented to TSG for information;
  - 2 presented to TSG for approval;
  - 3 Indicates TSG approved document under change control.
- y the second digit is incremented for all changes of substance, i.e. technical enhancements, corrections, updates, etc.
- z the third digit is incremented when editorial only changes have been incorporated in the specification;

---

## 1 Scope

This document establishes the Base Station minimum RF characteristics of the FDD mode of UTRA.

---

## 2 References

The following documents contain provisions, which, through reference in this text, constitute provisions of the present document.

- References are either specific (identified by date of publication, edition number, version number, etc.) or non-specific.
- For a specific reference, subsequent revisions do not apply.
- For a non-specific reference, subsequent revisions do apply.
- A non-specific reference to an ETS shall also be taken to refer to later versions published as an EN with the same number.

[1] ITU-R Recommendation SM.329-7, "Spurious emissions".

## 3 Definitions, symbols and abbreviations

### 3.1 Definitions

For the purposes of the present document, the following definitions apply:

Power Setting	The value of the control signal, which determines the desired transmitter, output Power. Typically, the power setting would be altered in response to power control commands
Maximum Power Setting	The highest value of the Power control setting which can be used.
Maximum output Power	This refers to the measure of power when averaged over the transmit timeslot at the maximum power setting.
Peak Power	The instantaneous power of the RF envelope which is not expected to be exceeded for [99.9%] of the time
Maximum peak power	The peak power observed when operating at a given maximum output power.
Average transmit power	The average transmitter output power obtained over any specified time interval, including periods with no transmission.
Maximum average power	The average transmitter output power obtained over any specified time interval, including periods with no transmission, when the transmit time slots are at the maximum power setting.

### 3.2 Symbols

For the purposes of the present document, the following symbols apply:

<symbol>      <Explanation>

### 3.3 Abbreviations

For the purposes of the present document, the following abbreviations apply:

<b>ACIR</b>	Adjacent Channel Interference Ratio
<b>ACLR</b>	Adjacent Channel Leakage power Ratio
<b>ACS</b>	Adjacent Channel Selectivity
<b>BS</b>	Base Station
<b>BER</b>	Bit Error Rate
<b>CW</b>	Continuous Wave (unmodulated signal)
<b>DL</b>	Down Link (forward link)
<b>EIRP</b>	Effective Isotropic Radiated Power
<b>FDD</b>	Frequency Division Duplexing
<b>FER</b>	Frame Error Rate
<b>MER</b>	Message Error Rate
<b>PPM</b>	Parts Per Million
<b>RSSI</b>	Received Signal Strength Indicator
<b>SIR</b>	Signal to Interference ratio
<b>TDD</b>	Time Division Duplexing
<b>TPC</b>	Transmit Power Control
<b>UE</b>	User Equipment
<b>UL</b>	Up Link (reverse link)
<b>UTRA</b>	UMTS Terrestrial Radio Access



---

## 4 General

### 4.1 Measurement uncertainty

The requirements given in this specification are absolute. Compliance with the requirement is determined by comparing the measured value with the specified limit, without making allowance for measurement uncertainty.

### 4.2 Base station classes

The requirements in this specification apply to base station intended for general-purpose applications.

In the future further classes of base stations may be defined; the requirements for these may be different than for general-purpose applications.

## 5 Frequency bands and channel arrangement

### 5.1 General

The information presented in this section is based on a chip rate of 3.84 Mcps.

Note

1. Other chip rates may be considered in future releases.

### 5.2 Frequency bands

UTRA/FDD is designed to operate in either of the following paired bands;

- (a) 1920 – 1980MHz: Up-link (Mobile transmit, base receive)  
2110 – 2170MHz: Down-link (Base transmit, mobile receive)

- (b) [FFS; for deployment in ITU Region 2]

Deployment in other frequency bands is not precluded.

### 5.3 Tx–Rx frequency separation

- (a) The minimum transmit to receive frequency separation is 134.8 MHz and the maximum value is 245.2 MHz when operating in the paired band defined in sub-clause 5.2 (a). All UE(s) shall support a TX –RX frequency separation of 190 MHz
- (b) UTRA/FDD can support both fixed and variable transmit to receive frequency separation.
- (c) The use of other transmit to receive frequency separations in other frequency bands shall not be precluded.

### 5.4 Channel arrangement

#### 5.4.1 Channel spacing

The nominal channel spacing is 5 MHz, but this can be adjusted to optimize performance in a particular deployment scenario.

#### 5.4.2 Channel raster

The channel raster is 200 kHz, which means that the center frequency must be an integer multiple of 200 kHz.

#### 5.4.3 Channel number

The carrier frequency is designated by the UTRA Absolute Radio Frequency Channel Number (UARFCN). The value of the UARFCN in the IMT2000 band is defined as follows;

**Table 1: UTRA Absolute Radio Frequency Channel Number**

Uplink	$N_u = 5 * (F_{\text{uplink}} - 1885.2 \text{ MHz})$	$1885.2 \text{ MHz} \leq F_{\text{uplink}} \leq 2024.8 \text{ MHz}$ where $F_{\text{uplink}}$ is the uplink frequency in MHz
Downlink	$N_d = 5 * (F_{\text{downlink}} - 2075.2 \text{ MHz})$	$2110.2 \text{ MHz} \leq F_{\text{downlink}} \leq 2199.8 \text{ MHz}$ where $F_{\text{downlink}}$ is the downlink frequency in MHz

---

## 6 Transmitter characteristics

### 6.1 General

Unless detailed the transmitter characteristic are specified at the antenna connector.

### 6.2 Base station output power

Output power,  $P_{out}$ , of the base station is the mean power of one carrier delivered to a load with resistance equal to the nominal load impedance of the transmitter during one slot.

#### 6.2.1 Base station maximum output power

Maximum output power,  $P_{max}$ , of the base station is the mean power level per carrier that the manufacturer has declared to be available at the antenna connector.

##### 6.2.1.1 Minimum requirement

In normal conditions, the Base station maximum output power shall remain within +2 dB and -2dB of the manufacturer's rated power.

In extreme conditions, the Base station maximum output power shall remain within +[ ] and -[ ] of the manufacturer's rated power.

### 6.3 Frequency stability

Frequency stability is ability of the BS to transmit at the assigned carrier frequency.

#### 6.3.1 Minimum requirement

The modulated carrier frequency of the BS shall be accurate to within  $\pm 0.05$  ppm for RF frequency generation.

### 6.4 Output power dynamics

Power control is used to limit the interference level. The transmitter uses a quality-based power control on both the uplink and downlink.

#### 6.4.1 Inner loop power control in the downlink

Inner loop power control in the downlink is the ability of the BS transmitter to adjust its output power in accordance with the TPC symbols received in the uplink.

##### 6.4.1.1 Power control steps

The power control step is the required step change in the DL transmitter output power in response to a power control command.

###### 6.4.1.1.1 Minimum requirement

The BS transmitter shall have the capability of setting the inner loop output power with a step sizes of 1dB mandatory and 0.5 dB optional

- (a) The tolerance of the transmitter output power step due to inner loop power control shall be within the range shown in Table 6.1.

- (b) The tolerance of the transmitter average output power step due to inner loop power control shall be within the range shown in Table 6.2.

**Table 6.1: Transmitter power control step tolerance**

Power control commands in the down link	Transmitter power control tolerance			
	1 dB step size		0.5 dB step size	
	Lower	Upper	Lower	Upper
Up	+0.5 dB	+1.5 dB	+0.25 dB	+0.75 dB
Down	-0.5 dB	-1.5 dB	-0.25 dB	-0.75 dB

**Table 6.2: Transmitter average power control step tolerance**

Power control commands in the down link	Transmitter power control tolerance after 10 equal commands (up or down)			
	1 dB step size		0.5dB step size	
	Lower	Upper	Lower	Upper
Up	+8 dB	+12 dB	+4 dB	+6 dB
Down	-8 dB	-12 dB	-4 dB	-6 dB

## 6.4.2 Power control dynamic range

The power control dynamic range is the difference between the maximum and the minimum transmit output power of a code channel for a specified reference condition.

### 6.4.2.1 Minimum requirements

Down link (DL) power control dynamic range:

Maximum power: BS maximum output power – 3 dB or greater  
 Minimum power: BS maximum output power – 28 dB or less

## 6.4.3 Total power dynamic range

The total power dynamic range is the difference between the maximum and the minimum total transmit output power for a specified reference condition.

Note: The upper limit of the dynamic range is the BS maximum output power. The lower limit of the dynamic range is the lowest minimum power from the BS when no traffic channels are activated.

### 6.4.3.1 Minimum requirement

The down link (DL) total power dynamic range shall be 18 dB or greater.

## 6.4.4 Power control cycles per second

This is the maximum rate for the DL transmitter power control steps.

The down link (DL) rate of power control steps shall be 1.5 kHz.

## 6.4.5 Primary CPICH power

Primary CPICH power is the transmission power of the Common Pilot Channel averaged over one frame. Primary CPICH power is indicated on the BCH.

### 6.4.5.1 Requirement

CPICH power shall be within  $\pm$ TBD of the value indicated by a signaling message.

## 6.6 Output RF spectrum emissions

### 6.6.1 Occupied bandwidth

Occupied bandwidth is a measure of the bandwidth containing 99% of the total integrated power for transmitted spectrum and is centered on the assigned channel frequency. The occupied channel bandwidth shall be less than 5 MHz based on a chip rate of 3.84 Mcps.

### 6.6.2 Out of band emission

Out of band emissions are unwanted emissions immediately outside the channel bandwidth resulting from the modulation process and non-linearity in the transmitter but excluding spurious emissions. This out of band emission limit is specified in terms of a spectrum emission mask or adjacent channel power ratio for the transmitter.

#### 6.6.2.1 Spectrum emission mask

The mask defined in Table 6.3 to 6.6 below may be mandatory in certain regions. In other regions this mask may not be applied.

For regions where this clause applies, the requirement shall be met by a base station transmitting on a single RF carrier configured in accordance with the manufacturer's specification. Emissions shall not exceed the maximum level specified by the mask in the frequency range with offset  $\Delta f$  from 2.5 MHz to  $\Delta f_{\max}$  from the carrier frequency. The maximum offset  $\Delta f_{\max}$  is either 12.5 MHz or the offset to the UMTS Tx band edge as defined in section 5.2, whichever is the greatest.

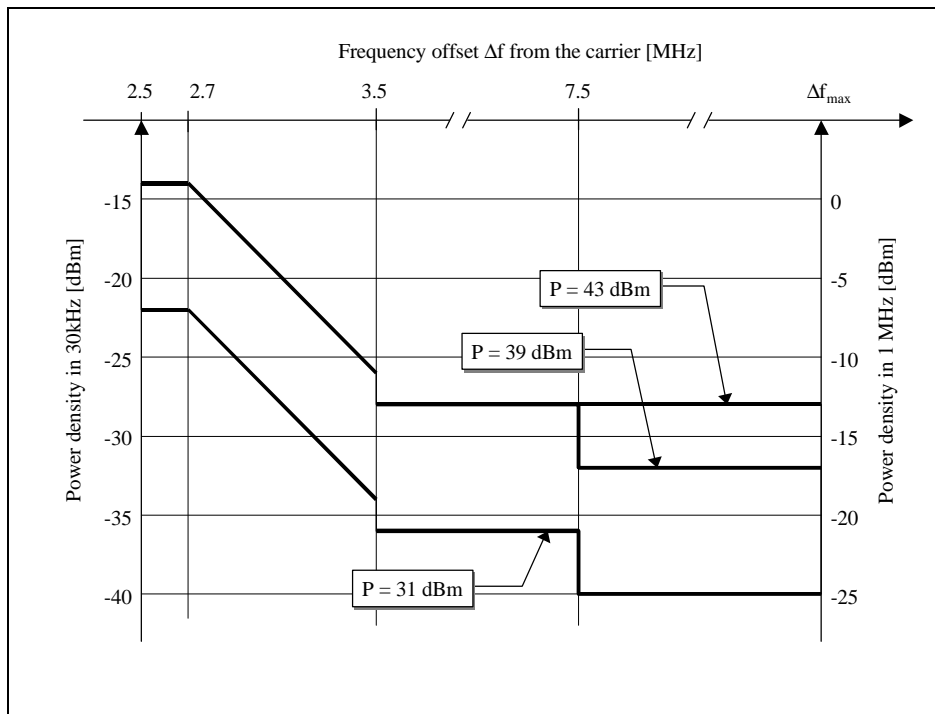

**Table 6.3: Spectrum emission mask values, BS maximum output power  $P \geq 43$  dBm**

Frequency offset $\Delta f$	Maximum level	Measurement bandwidth
$2.5 \leq \Delta f < 2.7$ MHz	-14 dBm	30 kHz <sup>1</sup>

$2.7 \leq \Delta f < 3.5$ MHz	$-14 - 15 \cdot (\Delta f - 2.7)$ dBm	30 kHz <sup>1</sup>
$3.5 \leq \Delta f \leq \Delta f_{\max}$ MHz	-13 dBm	1 MHz <sup>2</sup>

**Table 6.4: Spectrum emission mask values, BS maximum output power  $39 \leq P < 43$  dBm**

Frequency offset $\Delta f$	Maximum level	Measurement bandwidth
$2.5 \leq \Delta f < 2.7$ MHz	-14 dBm	30 kHz <sup>1</sup>
$2.7 \leq \Delta f < 3.5$ MHz	$-14 - 15 \cdot (\Delta f - 2.7)$ dBm	30 kHz <sup>1</sup>
$3.5 \leq \Delta f < 7.5$ MHz	-13 dBm	1 MHz <sup>2</sup>
$7.5 \leq \Delta f \leq \Delta f_{\max}$ MHz	$P - 56$ dBm	1 MHz <sup>2</sup>

**Table 6.5: Spectrum emission mask values, BS maximum output power  $31 \leq P < 39$  dBm**

Frequency offset $\Delta f$	Maximum level	Measurement bandwidth
$2.5 \leq \Delta f < 2.7$ MHz	$P - 53$ dBm	30 kHz <sup>1</sup>
$2.7 \leq \Delta f < 3.5$ MHz	$P - 53 - 15 \cdot (\Delta f - 2.7)$ dBm	30 kHz <sup>1</sup>
$3.5 \leq \Delta f < 7.5$ MHz	$P - 52$ dBm	1 MHz <sup>2</sup>
$7.5 \leq \Delta f \leq \Delta f_{\max}$ MHz	$P - 56$ dBm	1 MHz <sup>2</sup>

**Table 6.6: Spectrum emission mask values, BS maximum output power  $P < 31$  dBm**

Frequency offset $\Delta f$	Maximum level	Measurement bandwidth
$2.5 \leq \Delta f < 2.7$ MHz	-22 dBm	30 kHz <sup>1</sup>
$2.7 \leq \Delta f < 3.5$ MHz	$-22 - 15 \cdot (\Delta f - 2.7)$ dBm	30 kHz <sup>1</sup>
$3.5 \leq \Delta f < 7.5$ MHz	-21 dBm	1 MHz <sup>2</sup>
$7.5 \leq \Delta f \leq \Delta f_{\max}$ MHz	-25 dBm	1 MHz <sup>2</sup>

Notes:

1. The first and last measurement positions with a 30 kHz filter are 2.515 MHz and 3.485 MHz
2. The first and last measurement positions with a 1 MHz filter are 4 MHz and  $(\Delta f_{\max} - 500)$  kHz

### 6.6.2.2 Adjacent Channel Leakage power Ratio (ACLR)

Adjacent Channel Leakage power Ratio (ACLR) is the ratio of the transmitted power to the power measured after a receiver filter in the adjacent channel(s). Both the transmitted power and the received power are measured through a matched filter (Root Raised Cosine and roll-off 0.22) with a noise power bandwidth equal to the chip rate.

#### 6.6.2.2.1 Minimum requirement

The ACLR shall be better than the value specified in Table 6.7.

**Table 6.7: BS ACLR**

BS adjacent channel offset	ACLR limit
$\pm 5$ MHz	45 dB
$\pm 10$ MHz	50 dB

### 6.6.2.3 Protection outside a licensee's frequency block

This requirement is applicable if protection is required outside a licensee's defined frequency block.

#### 6.6.2.3.1 Minimum requirement

This requirement applies for frequencies outside the licensee's frequency block, up to an offset of 12.5MHz from a carrier frequency.

The power of any emission shall be attenuated below the transmit power (P) by at least  $43 + 10 \log (P)$  dB. Compliance with this provision is based on the use of measurement instrumentation employing a resolution bandwidth of 1MHz or greater. However, in the 1MHz bands immediately outside and adjacent to the frequency block a resolution bandwidth of at least one percent of the fundamental emission of the transmitter may be employed. The emission bandwidth is defined as the width of the signal between two points, one below the carrier centre frequency and one above the carrier centre frequency, outside of which all emissions are attenuated at least 26dB below the transmitter power.

When measuring the emission limits, the nominal carrier frequency shall be adjusted as close to the licensee's frequency block edges, both upper and lower, as the design permits. The measurements of emission power shall be mean power.

### 6.6.3 Spurious emissions

Spurious emissions are emissions which are caused by unwanted transmitter effects such as harmonics emission, parasitic emission, intermodulation products and frequency conversion products, but exclude out of band emissions. This is measured at the base station RF output port.

Unless otherwise stated, all requirements are measured as mean power.

#### 6.6.3.1 Mandatory Requirements

The requirements of either subclause 6.6.3.1.1 or subclause 6.6.3.1.2 shall apply whatever the type of transmitter considered (single carrier or multi-carrier). It applies for all transmission modes foreseen by the manufacturer's specification.

Either requirement applies at frequencies within the specified frequency ranges which are more than 12.5MHz under the first carrier frequency used or more than 12.5MHz above the last carrier frequency used.

##### 6.6.3.1.1 Spurious emissions (Category A)

The following requirements shall be met in cases where Category A limits for spurious emissions, as defined in ITU-R Recommendation SM.329-7 [1], are applied.

###### 6.6.3.1.1.1 Minimum Requirement

The power of any spurious emission shall not exceed:

**Table 6.8: BS Mandatory spurious emissions limits, Category A**

Band	Maximum level	Measurement Bandwidth	Note
9kHz – 150kHz	-13 dBm	1 kHz	Bandwidth as in ITU-R SM.329-7, s4.1
150kHz – 30MHz		10 kHz	Bandwidth as in ITU-R SM.329-7, s4.1
30MHz – 1GHz		100 kHz	Bandwidth as in ITU-R SM.329-7, s4.1
1GHz – 12.75 GHz		1 MHz	Upper frequency as in ITU-R SM.329-7, s2.6

##### 6.6.3.1.2 Spurious emissions (Category B)

The following requirements shall be met in cases where Category B limits for spurious emissions, as defined in ITU-R Recommendation SM.329-7 [1], are applied.

## 6.6.3.1.2.1 Minimum Requirement

The power of any spurious emission shall not exceed:

**Table 6.9: BS Mandatory spurious emissions limits, Category B**

Band	Maximum Level	Measurement Bandwidth	Note
9kHz ↔ 150kHz	-36 dBm	1 kHz	Bandwidth as in ITU-R SM.329-7, s4.1
150kHz ↔ 30MHz	- 36 dBm	10 kHz	Bandwidth as in ITU-R SM.329-7, s4.1
30MHz ↔ 1GHz	-36 dBm	100 kHz	Bandwidth as in ITU-R SM.329-7, s4.1
1GHz ↔ Fc1 - 60 MHz or 2100 MHz <i>whichever is the higher</i>	-30 dBm	1 MHz	Bandwidth as in ITU-R SM.329-7, s4.1
Fc1 - 60 MHz or 2100 MHz <i>whichever is the higher</i> ↔ Fc2 + 60 MHz or 2180 MHz <i>whichever is the lower</i>	-13 dBm	1 MHz	Specification equal to Cat. A Bandwidth as in ITU-R SM.329-7, s4.1
Fc2 + 60 MHz or 2180 MHz <i>whichever is the lower</i> ↔ 12.75 GHz	-30 dBm	1 MHz	Bandwidth as in ITU-R SM.329-7, s4.1. Upper frequency as in ITU-R SM.329-7, s2.6

Fc1 : Center frequency of first carrier frequency used.

Fc2 : Center frequency of last carrier frequency used.

## 6.6.3.2. Protection of the BS receiver

This requirement may be applied in order to prevent the receiver of the BS being desensitised by emissions from the BS transmitter which are coupled between the antennas of the BS. This is measured at the transmit antenna port.

## 6.6.3.2.1 Minimum Requirement

The power of any spurious emission shall not exceed:

**Table 6.10: BS Spurious emissions limits for protection of the BS receiver**

Band	Maximum Level	Measurement Bandwidth	Note
1920 – 1980MHz	-94 dBm	100 kHz	

## 6.6.3.3 Co-existence with GSM 900

## 6.6.3.3.1 Operation in the same geographic area

This requirement may be applied for the protection of GSM 900 MS in geographic areas in which both GSM 900 and UTRA are deployed.

[This requirement assumes the scenario described in 25.942.] For different scenarios, the manufacturer may declare a different requirement.

## 6.6.3.3.1.1 Minimum Requirement

The power of any spurious emission shall not exceed:

**Table 6.11: BS Spurious emissions limits for BS in geographic coverage area of GSM 900**



Band	Maximum Level	Measurement Bandwidth	Note
921 – 960 MHz	-47 dBm	100 kHz	

#### 6.6.3.3.2 Co-located base stations

This requirement may be applied for the protection of GSM 900 BTS receivers when GSM 900 BTS and UTRA BS are co-located.

[This requirement assumes the scenario described in 25.942.] For different scenarios, the manufacturer may declare a different requirement.

##### 6.6.3.3.2.1 Minimum Requirement

The power of any spurious emission shall not exceed:

**Table 6.12: BS Spurious emissions limits for protection of the BS receiver**

Band	Maximum Level	Measurement Bandwidth	Note
876-915 MHz	-[98]dBm	100 kHz	

#### 6.6.3.4 Co-existence with DCS 1800

##### 6.6.3.4.1 Operation in the same geographic area

This requirement may be applied for the protection of DCS 1800 MS in geographic areas in which both DCS 1800 and UTRA are deployed.

[This requirement assumes the scenario described in 25.942.] For different scenarios, the manufacturer may declare a different requirement.

##### 6.6.3.4.1.1 Minimum Requirement

The power of any spurious emission shall not exceed:

**Table 6.13: BS Spurious emissions limits for BS in geographic coverage area of DCS 1800**

Band	Maximum Level	Measurement Bandwidth	Note
1805 – 1880 MHz	-57 dBm	100 kHz	

##### 6.6.3.4.2 Co-located base stations

This requirement may be applied for the protection of DCS 1800 BTS receivers when DCS 1800 BTS and UTRA BS are co-located.

[This requirement assumes the scenario described in 25.942.] For different scenarios, the manufacturer may declare a different requirement.

##### 6.6.3.4.2.1 Minimum Requirement

The power of any spurious emission shall not exceed:

**Table 6.14: BS Spurious emissions limits for BS co-located with DCS 1800 BTS**

Band	Maximum Level	Measurement Bandwidth	Note
1710-1785 MHz	-[98]dBm	100 kHz	

### 6.6.3.5 Co-existence with PHS

This requirement may be applied for the protection of PHS in geographic areas in which both PHS and UTRA are deployed.

#### 6.6.3.5.1 Minimum Requirement

The power of any spurious emission shall not exceed:

**Table 6.15: BS Spurious emissions limits for BS in geographic coverage area of PHS**

Band	Maximum Level	Measurement Bandwidth	Note
1893.5 – 1919.6 MHz	-41 dBm	300 kHz	

### 6.6.3.6 Co-existence with services in adjacent frequency bands

This requirement may be applied for the protection in bands adjacent to 2110-2170 MHz in geographic areas in which both an adjacent band service and UTRA are deployed.

#### 6.6.3.6.1 Minimum requirement

The power of any spurious emission shall not exceed:

**Table 6.16: BS spurious emissions limits for protection of adjacent band services**

Band (f)	Maximum Level	Measurement Bandwidth	Note
2100-2105 MHz	$-30 + 3.4 \cdot (f - 2100 \text{ MHz}) \text{ dBm}$	1 MHz	
2175-2180 MHz	$-30 + 3.4 \cdot (2180 \text{ MHz} - f) \text{ dBm}$	1 MHz	

## 6.7 Transmit intermodulation

The transmit intermodulation performance is a measure of the capability of the transmitter to inhibit the generation of signals in its non linear elements caused by presence of the wanted signal and an interfering signal reaching the transmitter via the antenna.

The transmit intermodulation level is the power of the intermodulation products when a WCDMA modulated interference signal is injected into the antenna connector at a level of 30 dB lower than that of the subject signal. The frequency of the interference signal shall be  $\pm 5$  MHz,  $\pm 10$  MHz and  $\pm 15$  MHz offset from the subject signal.

### 6.7.1 Minimum requirement

The transmit intermodulation level shall not exceed the out of band emission or the spurious emission requirements of section 6.6.2 and 6.6.3.

## 6.8 Transmit modulation

### 6.8.1 Transmit pulse shape filter

The transmit pulse-shaping filter is a root-raised cosine (RRC) with roll-off  $\alpha = 0.22$  in the frequency domain. The impulse response of the chip impulse filter  $RC_0(t)$  is

$$RC_0(t) = \frac{\sin\left(p \frac{t}{T_c}(1-a)\right) + 4a \frac{t}{T_c} \cos\left(p \frac{t}{T_c}(1+a)\right)}{p \frac{t}{T_c} \left(1 - \left(4a \frac{t}{T_c}\right)^2\right)}$$

$$T_c = \frac{1}{\text{chiprate}} \approx 0.26042 \text{ms}$$

Where the roll-off factor  $\alpha = 0.22$  and the chip duration:

## 6.8.2 Modulation Accuracy

The modulation accuracy is a measure of the difference between the measured waveform and the theoretical modulated waveform (the error vector). It is the square root of the ratio of the mean error vector power to the mean reference signal power expressed as a %. The measurement interval is one power control group (timeslot)

### 6.8.2.1 Minimum requirement

The Modulation accuracy shall not be worse than 12.5 %.

## 6.8.3 Peak code Domain error

The code domain error is computed by projecting the error vector power onto the code domain at the maximum spreading factor. The error vector for each power code is defined as the ratio to the mean power of the reference waveform expressed in dB. The peak code domain error is defined as the maximum value for the code domain error. The measurement interval is one power control group (timeslot).

### 6.8.3.1 Minimum requirement

The peak code domain error shall not exceed [ ] dB

## 7 Receiver characteristics

### 7.1 General

Unless detailed the receiver characteristic are specified at each antenna connector of the BS.

### 7.2 Reference sensitivity level

The reference sensitivity is the minimum receiver input power measured at the antenna connector at which the Bit Error Rate (BER) does not exceed the specific value indicated in section 7.2.1. The signal power is equally applied to each antenna connector for diversity.

#### 7.2.1 Minimum requirement

For the measurement channel specified in Annex A, the reference sensitivity level and performance of the BS shall be as specified in Table 7.1.

**Table 7.1: BS reference sensitivity levels**

Measurement channel	BS reference sensitivity level (dBm)	BER
12.2 kbps	-122 dBm	BER shall not exceed 0.001

#### 7.2.2 Maximum Frequency Deviation for Receiver Performance

The need for such a requirement is for further study.

### 7.3 Dynamic range

The receiver dynamic range is the input power range at each BS antenna connector over which the [FER/BER] does not exceed a specific rate.

The static [BER/BER] reference performance as specified in clause 7.2.1 should be met over a receiver input range of [30] dB above the specified reference sensitivity level for [channel type ffs].

### 7.4 Adjacent Channel Selectivity (ACS)

Adjacent channel selectivity (ACS) is a measure of the receiver ability to receive a wanted signal at its assigned channel frequency in the presence of an adjacent channel signal at a given frequency offset from the center frequency of the assigned channel. ACS is the ratio of the receiver filter attenuation on the assigned channel frequency to the receive filter attenuation on the adjacent channel(s).

#### 7.4.1 Minimum requirement

The BER shall not exceed 0.001 for the parameters specified in Table 7.2.

**Table 7.2 : Adjacent channel selectivity**

Parameter	Level	Unit
Data rate	12.2	kbps
Wanted signal	Reference sensitivity level	dBm

	+ 6dB	
Interfering signal	-52	dBm
Fuw (Modulated)	5	MHz

## 7.5 Blocking characteristics

The blocking characteristics is a measure of the receiver ability to receive a wanted signal at its assigned channel frequency in the presence of an unwanted interferer on frequencies other than those of the spurious response or the adjacent channels; without this unwanted input signal causing a degradation of the performance of the receiver beyond a specified limit.

### 7.5.1 Minimum requirement

The static reference performance as specified in clause 7.2.1 should be met with a wanted and an interfering signal coupled to BS antenna input using the following parameters.

**Table 7.3 : Blocking performance requirement**

Center Frequency of Interfering Signal	Interfering Signal Level	Wanted Signal Level	Minimum Offset of Interfering Signal	Type of Interfering Signal
1920 – 1980 MHz	-40 dBm	<REFSENS> + 6 dB	10 MHz	WCDMA signal with one code
1900 – 1920 MHz 1980 – 2000 MHz	-40 dBm	<REFSENS> + 6 dB	10 MHz	WCDMA signal with one code
<1900, > 2000 MHz	-15 dBm	<REFSENS> + 6 dB	—	CW carrier

## 7.6 Intermodulation characteristics

Third and higher order mixing of the two interfering RF signals can produce an interfering signal in the band of the desired channel. Intermodulation response rejection is a measure of the capability of the receiver to receive a wanted signal on its assigned channel frequency in the presence of two or more interfering signals which have a specific frequency relationship to the wanted signal.

### 7.6.1 Minimum requirement

The static reference performance as specified in clause 7.2.1 should be met when the following signals are coupled to BS antenna input

- A wanted signal at the assigned channel frequency, 6 dB above the static reference level.
- Two interfering signals with the following parameters.

**Table 7.3 : Intermodulation performance requirement**

Interfering Signal Level	Offset	Type of Interfering Signal
- 48 dBm	10 MHz	CW signal
- 48 dBm	20 MHz	WCDMA signal with one code

## 7.7 Spurious emissions

The spurious emissions power is the power of emissions generated or amplified in a receiver that appear at the BS receiver antenna connector.

### 7.7.1 Minimum requirement

The spurious emission shall be:

- (a) Less than  $-78$  dBm/3.84 MHz at the BS receiver antenna connector, for frequencies within the BS receive band.
- (b) Less than  $-57$  dBm/100 kHz at the BS receiver antenna connector, for frequencies band from 9kHz to 1GHz.
- (c) Less than  $-47$  dBm/100 kHz at the BS receiver antenna connector, for frequencies band from 1GHz to 12.75 GHz.

## 8 Performance requirement

### 8.1 General

Performance requirements for the BS are specified for the measurement channels defined in Annex A and the propagation conditions in Annex B. The requirements only apply to those measurement channels that are supported by the base station.

The requirements only apply to a base station with dual receiver antenna diversity. The required  $E_b/N_0$  shall be applied separately at each antenna port.

**Table 8.1: Summary of Base Station performance targets**

Physical channel	Measurement channel	Static	Multi-path Case 1	Multi-path Case 2	Multi-path Case 3	Moving	Birth / Death
		Performance metric					
DCH	12.2 kbps	BLER < $10^{-2}$	BLER < $10^{-2}$	BLER < $10^{-2}$	BLER < $10^{-2}$	BLER <	BLER <
	64 kbps	BLER < $10^{-1}, 10^{-2}$	BLER < $10^{-1}, 10^{-2}$	BLER < $10^{-1}, 10^{-2}$	BLER < $10^{-1}, 10^{-2}, 10^{-3}$	BLER <	BLER <
	144 kbps	BLER < $10^{-1}, 10^{-2}$	BLER < $10^{-1}, 10^{-2}$	BLER < $10^{-1}, 10^{-2}$	BLER < $10^{-1}, 10^{-2}, 10^{-3}$	-	-
	384 kbps	BLER < $10^{-1}, 10^{-2}$	BLER < $10^{-1}, 10^{-2}$	BLER < $10^{-1}, 10^{-2}$	BLER < $10^{-1}, 10^{-2}, 10^{-3}$	-	-

### 8.2 Demodulation in static propagation conditions

#### 8.2.1 Demodulation of DCH

The performance requirement of DCH in static propagation conditions is determined by the maximum Block Error Rate (BLER) allowed when the receiver input signal is at a specified  $E_b/N_0$  limit. The BLER is calculated for each of the measurement channels supported by the base station.

##### 8.2.1.1 Minimum requirement

The BLER should not exceed the limit for the  $E_b/N_0$  specified in Table 8.2.

**Table 8.2: Performance requirements in AWGN channel.**

Measurement channel	Required $E_b/N_0$ BLER < $10^{-1}$	Required $E_b/N_0$ BLER < $10^{-2}$
12.2 kbps	n.a.	
64 kbps		
144 kbps		
384 kbps		

### 8.3 Demodulation of DCH in multipath fading conditions

#### 8.3.1 Multipath fading Case 1

The performance requirement of DCH in multipath fading Case 1 is determined by the maximum Block Error Rate (BLER) allowed when the receiver input signal is at a specified  $E_b/N_0$  limit. The BLER is calculated for each of the measurement channels supported by the base station.

### 8.3.1.1 Minimum requirement

The BLER should not exceed the limit for the  $E_b/N_0$  specified in Table 8.3.

**Table 8.3: Performance requirements in multipath Case 1 channel.**

Measurement channel	Required $E_b/N_0$ BLER < $10^{-1}$	Required $E_b/N_0$ BLER < $10^{-2}$
12.2 kbps	n.a.	
64 kbps		
144 kbps		
384 kbps		

### 8.3.2 Multipath fading Case 2

The performance requirement of DCH in multipath fading Case 2 is determined by the maximum Block Error Rate (BLER) allowed when the receiver input signal is at a specified  $E_b/N_0$  limit. The BLER is calculated for each of the measurement channels supported by the base station.

#### 8.3.2.1 Minimum requirement

The BLER should not exceed the limit for the  $E_b/N_0$  specified in Table 8.4.

**Table 8.4: Performance requirements in multipath Case 2 channel.**

Measurement channel	Required $E_b/N_0$ BLER < $10^{-1}$	Required $E_b/N_0$ BLER < $10^{-2}$
12.2 kbps	n.a.	
64 kbps		
144 kbps		
384 kbps		

### 8.3.3 Multipath fading Case 3

The performance requirement of DCH in multipath fading Case 3 is determined by the maximum Block Error Rate (BLER) allowed when the receiver input signal is at a specified  $E_b/N_0$  limit. The BLER is calculated for each of the measurement channels supported by the base station.

#### 8.3.3.1 Minimum requirement

The BLER should not exceed the limit for the  $E_b/N_0$  specified in Table 8.5.

**Table 8.5: Performance requirements in multipath Case 3 channel.**

Measurement channel	Required $E_b/N_0$ BLER < $10^{-1}$	Required $E_b/N_0$ BLER < $10^{-2}$	Required $E_b/N_0$ BLER < $10^{-3}$
12.2 kbps	n.a.		
64 kbps			
144 kbps			
384 kbps			



## 8.4 Demodulation of DCH in moving propagation conditions

The performance requirement of DCH in moving propagation conditions is determined by the maximum Block Error Rate (BLER) allowed when the receiver input signal is at a specified  $E_b/N_0$  limit. The BLER is calculated for each of the measurement channels supported by the base station.

### 8.4.1 Minimum requirement

The BLER should not exceed the limit for the  $E_b/N_0$  specified in Table 8.6.

**Table 8.6: Performance requirements in moving channel.**

Measurement channel	Required $E_b/N_0$ BLER < $10^{-1}$	Required $E_b/N_0$ BLER < $10^{-2}$
12.2 kbps	n.a.	
64 kbps		
144 kbps		
384 kbps		

## 8.5 Demodulation of DCH in birth/death propagation conditions

The performance requirement of DCH in birth/death propagation conditions is determined by the maximum Block Error Rate (BLER) allowed when the receiver input signal is at a specified  $E_b/N_0$  limit. The BLER is calculated for each of the measurement channels supported by the base station.

### 8.5.1 Minimum requirement

The BLER should not exceed the limit for the  $E_b/N_0$  specified in Table 8.7.

**Table 8.7: Performance requirements in birth/death channel.**

Measurement channel	Required $E_b/N_0$ BLER < $10^{-1}$	Required $E_b/N_0$ BLER < $10^{-2}$
12.2 kbps	n.a.	
64 kbps		
144 kbps		
384 kbps		

## Annex A (normative): Measurement channels

### A.1 Summary of UL reference measurement channels

The parameters for the UL reference measurement channels are specified in Table A.1 and the channel coding is detailed in figure A.1 through A.5 respectively. Note that for all cases, one DPCCH shall be attached to DPDCH(s).

**Table A.1: Reference measurement channels for UL DCH**

Parameter		DCH for DTCH / DCH for DCCH					Unit
DPDCH	Information bit rate	12.2/2.4	64/2.4	144/2.4	384/2.4	2048/2.4	kbps
	Physical channel	60/15	240/15	480/15	960/15	960/15	kbps
	Spreading factor	64	16	8	4	4	
	Repetition rate	23/17	19/17	9/0	-17/-18	-6.5/0	%
	Interleaving	20	40	40	40	80	ms
	Number of DPDCHs	1	1	1	1	6	
DPCCH	Dedicated pilot	6					bit/slot
	Power control	2					bit/slot
	TFCI	2					bit/slot
	Spreading factor	256					
Power ratio of DPCCH/DPDCH		-2.69	-5.46	-9.54	-9.54	-9.54	dB
Amplitude ratio of DPCCH/DPDCH		0.7333	0.5333	0.3333	0.3333	0.3333	

## A.2 UL reference measurement channel for 12.2 kbps

The parameters for the UL reference measurement channel for 12.2 kbps are specified in Table A.2 and the channel coding is detailed in Figure A.2.

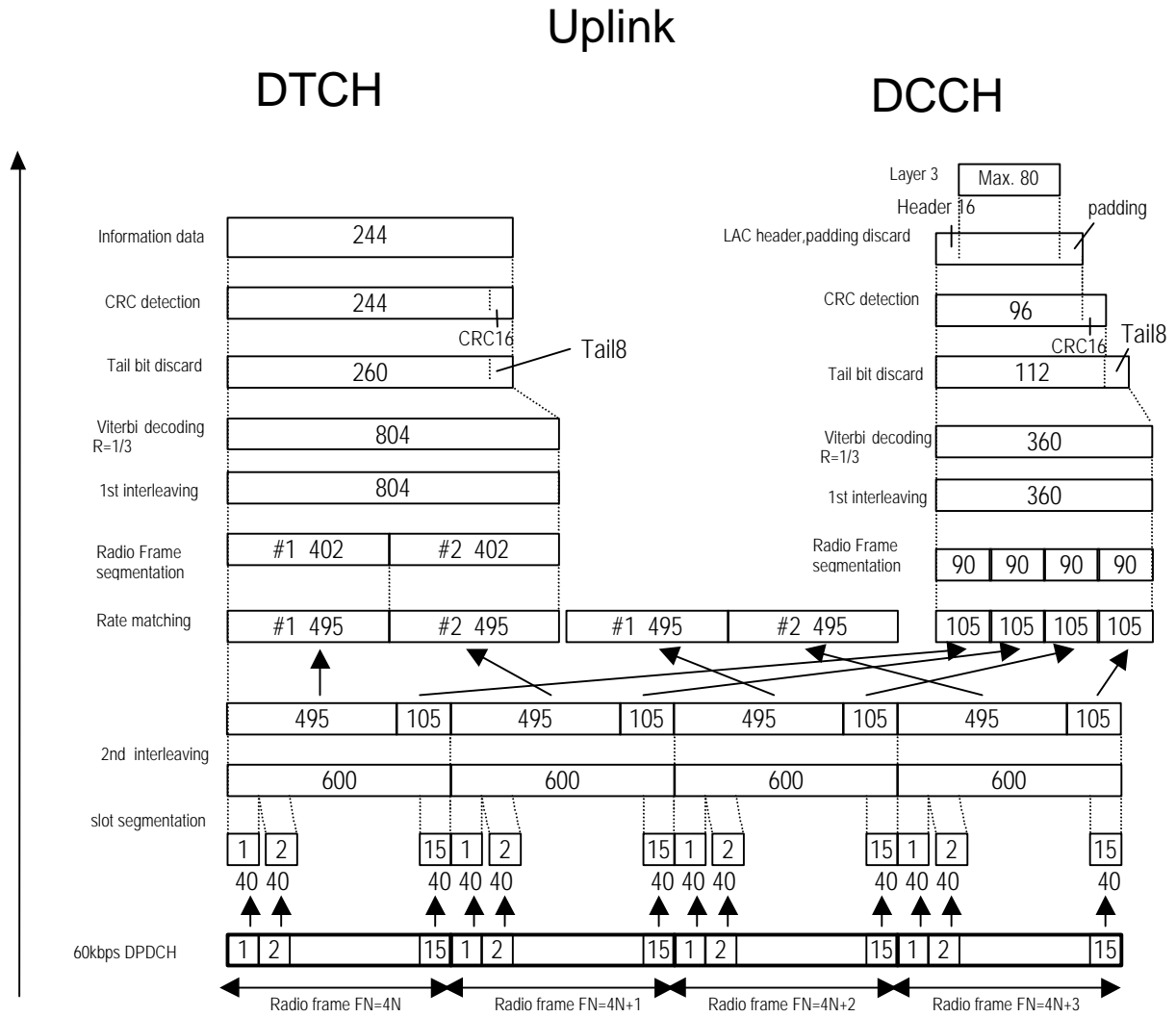
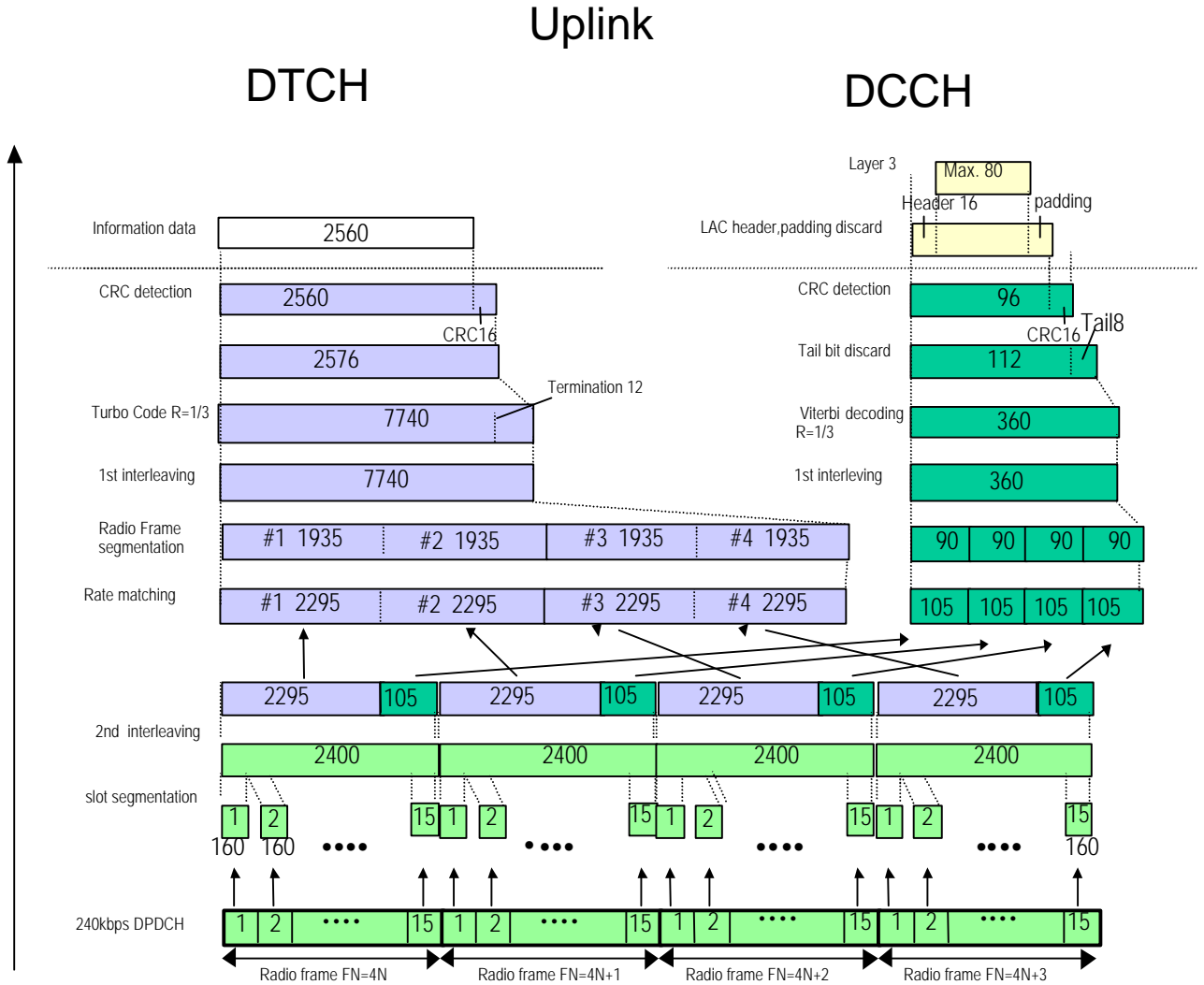

**Table A.2: UL reference measurement channel (12.2 kbps)**

Parameter	Level	Unit
Information bit rate	12.2	kbps
DPCH	60	kbps
Power control	Off	
TFCI	On	
Repetition	23	%

### A.3 UL reference measurement channel for 64 kbps

The parameters for the UL reference measurement channel for 64 kbps are specified in Table A.3 and the channel coding is detailed in Figure A.3.

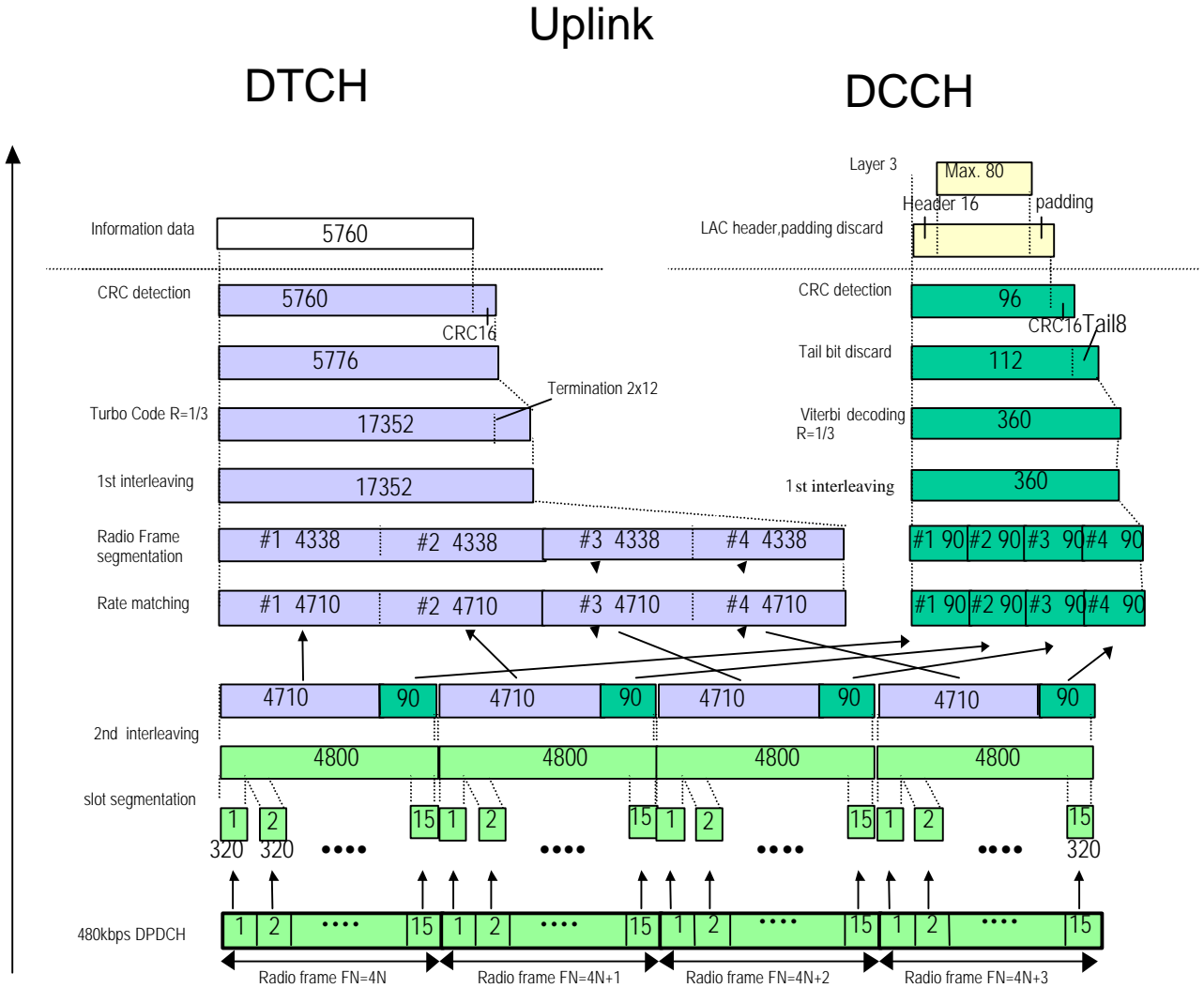

**Table A.3: UL reference measurement channel (64kbps)**

Parameter	Level	Unit
Information bit rate	64	kbps
DPCH	240	kbps
Power control	Off	
TFCI	On	
Repetition	19	%

## A.4 UL reference measurement channel for 144 kbps

The parameters for the UL reference measurement channel for 144 kbps are specified in Table A.4 and the channel coding is detailed in Figure A.4.

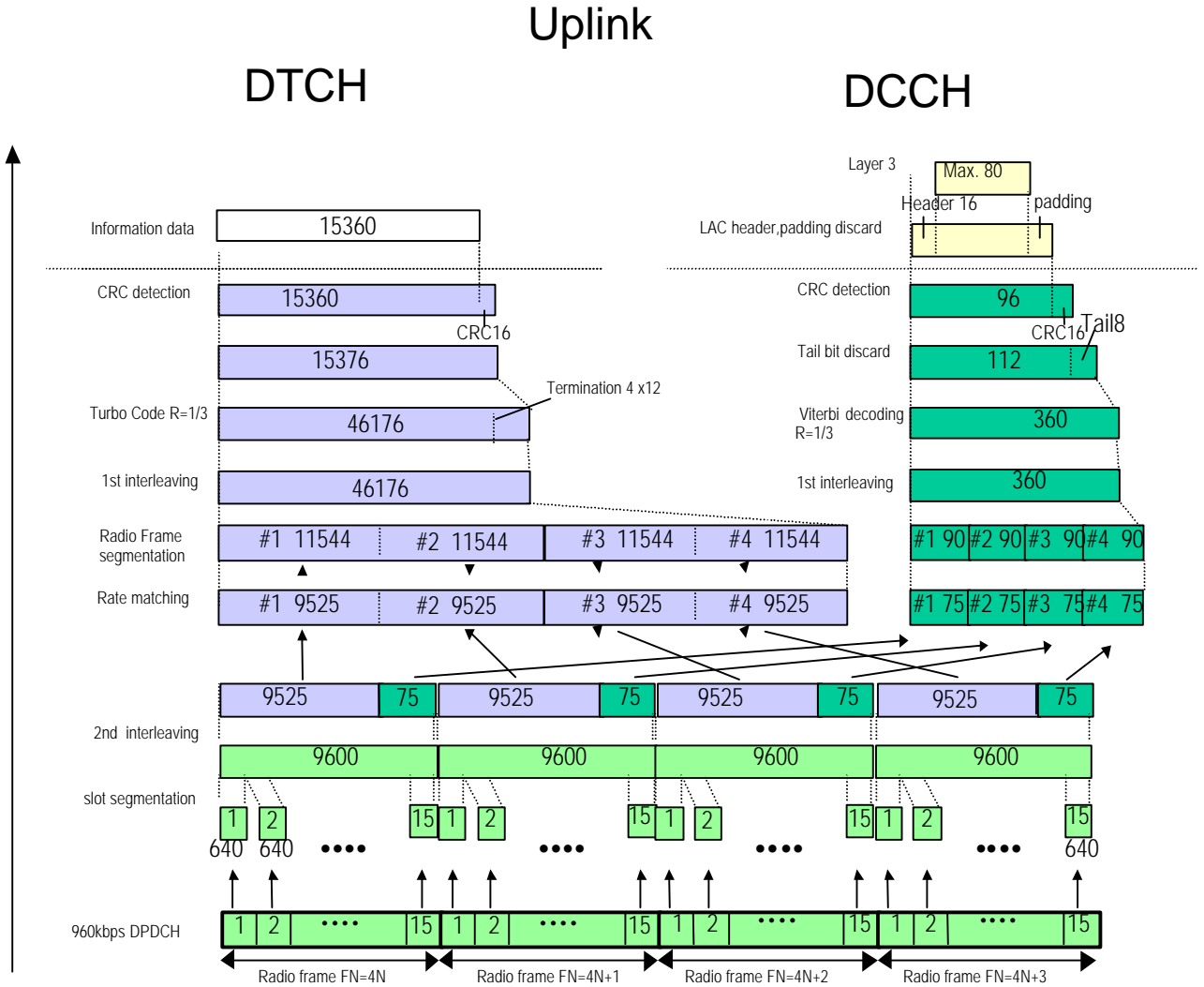

**Table A.4: UL reference measurement channel (144kbps)**

Parameter	Level	Unit
Information bit rate	144	kbps
DPCH	480	kbps
Power control	Off	
TFCI	On	
Repetition	9	%

## A.5 UL reference measurement channel for 384 kbps

The parameters for the UL reference measurement channel for 384 kbps are specified in Table A.5 and the channel coding is detailed in Figure A.5.

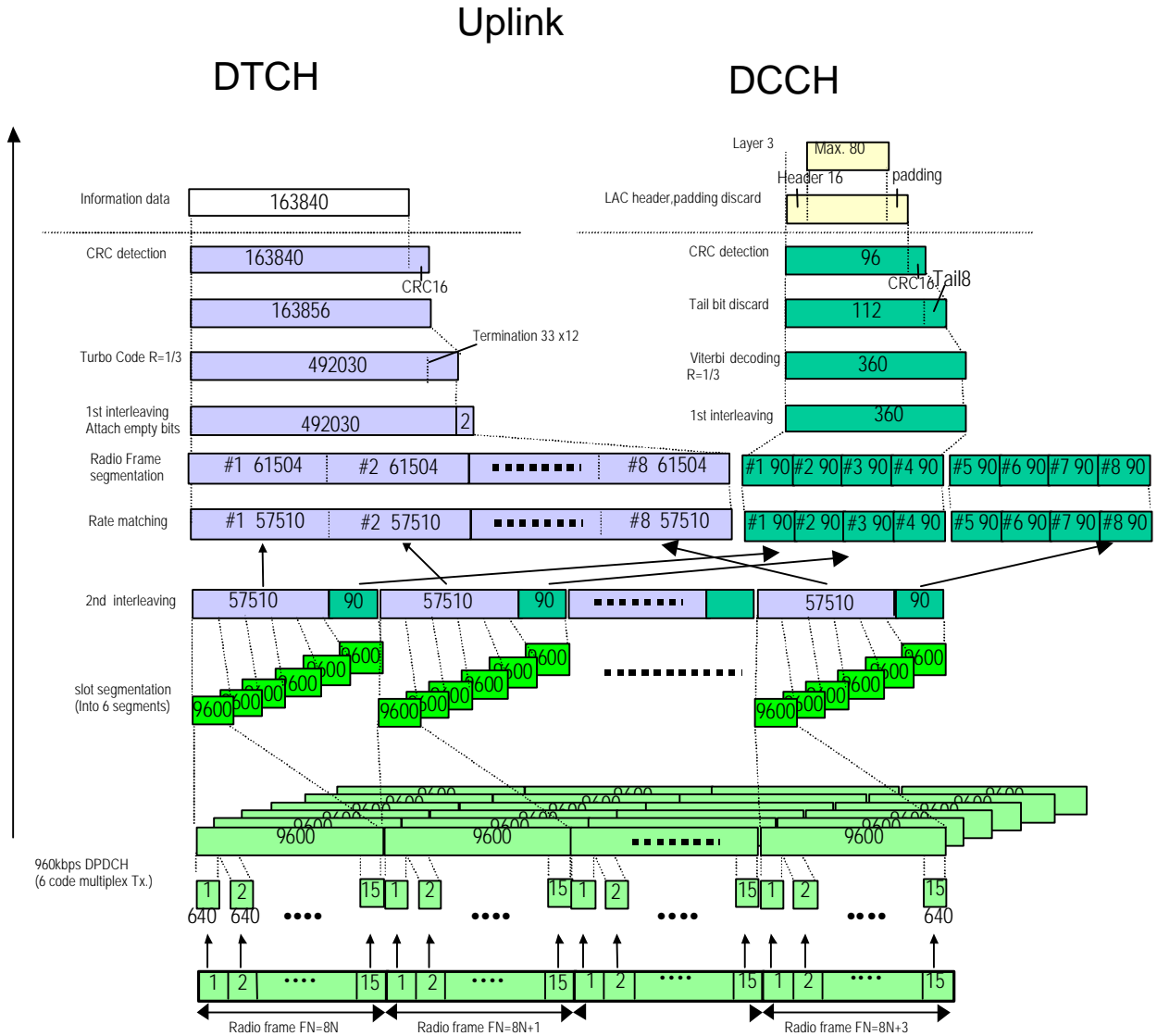

**Table A.5: UL reference measurement channel (384kbps)**

Parameter	Level	Unit
Information bit rate	384	kbps
DPCH	960	kbps
Power control	Off	
TFCI	On	
Puncturing	17	%

## A.6 UL reference measurement channel for 2048 kbps

The parameters for the UL reference measurement channel for 2048 kbps are specified in Table A.6 and the channel coding is detailed in Figure A.6.



**Table A.6: UL reference measurement channel (2048kbps)**

Parameter	Level	Unit
Information bit rate	2048	Kbps
DPCH	960	Kbps
Power control	Off	
TFCI	On	
Puncturing	6.5	%

## Annex B (normative): Propagation conditions

### B.1 Static propagation condition

The propagation for the static performance measurement is an Additive White Gaussian Noise (AWGN) environment. No fading or multi-paths exist for this propagation model.

### B.2 Multi-path fading propagation conditions

Table B.1 shows propagation conditions that are used for the performance measurements in multi-path fading environment. All taps have classical Doppler spectrum.

**Table B.1: Propagation Conditions for Multi path Fading Environments**

Case 1, speed 3km/h		Case 2, speed 3 km/h		Case 3, 120 km/h	
Relative Delay [ns]	Average Power [dB]	Relative Delay [ns]	Average Power [dB]	Relative Delay [ns]	Average Power [dB]
0	0	0	0	0	0
976	-10	976	0	260	-3
		20000	0	521	-6
				781	-9

### B.3 Moving propagation conditions

The dynamic propagation conditions for the test of the baseband performance are non-fading channel models with two taps. The moving propagation condition has two tap, one static, Path0, and one moving, Path1. The time difference between the two paths is according Equation (B.1). The parameters for the equation are shown in Table B.2.

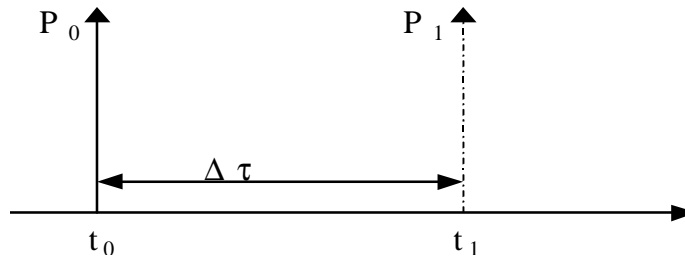

**Figure B.1 The moving propagation conditions**

$$\Delta t = \left( 1 + \frac{A}{2} (1 + \sin(\Delta \omega \cdot t)) \right) \quad (B.1)$$

**Table B.2: Parameters for moving propagation**

<b>A</b>	5 μs
<b>Δω</b>	40·10 <sup>-3</sup> s <sup>-1</sup>



## B.4 Birth-Death propagation conditions

The dynamic propagation conditions for the test of the baseband performance is a non-fading propagation channel with two taps. The moving propagation conditions has two taps, Path1 and Path2 which alternate between 'birth' and 'death'. The positions the paths appear are randomly selected with an equal probability rate and is shown in Figure B.2.

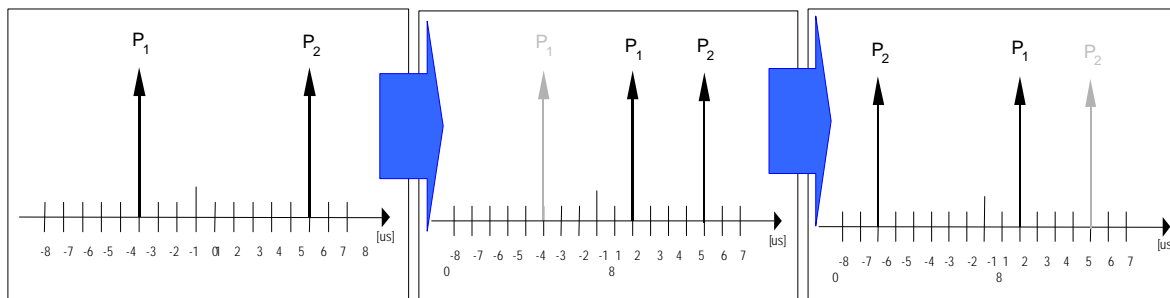

**Figure B.2: Birth death propagation sequence**

### Note

1. Two paths, Path1 and Path2 are randomly selected between  $-5\mu\text{s}$  and  $+5\mu\text{s}$ .
2. After 191 ms, Path1 vanishes and reappears immediately at a new location randomly selected between  $-8\mu\text{s}$  and  $+8\mu\text{s}$  but excludes the point Path2.
3. After an additional 191 ms, Path2 vanishes and reappears immediately at a new location randomly selected between  $-5\mu\text{s}$  and  $+5\mu\text{s}$  but excludes the point Path1.
4. The sequence in 2) and 3) is repeated.

## Annex C (informative): Open items

Section number	Section description	Status
6.2.1	Base station max output power	Minimum requirement in extreme conditions is ffs.
6.3	Frequency accuracy	Should there also be an accuracy requirement on the clock rate? Alternatives are to either tie the clock rate to the frequency accuracy or to have a separate clock rate requirement.
6.4.2	Power control dynamic range	The need for this parameter to be specified should be confirmed. The power control dynamic range necessary as a minimum requirement needs to be reviewed.
6.4.3	Total power dynamic range	The total power dynamic range necessary as a minimum requirement needs to be reviewed.
6.4.5	Primary CPICH power	Value is TBD. Details of the path loss estimation method is under study in WG1.
6.6.1	Occupied bandwidth	Measurement bandwidth for the total integrated power is ffs. Is this section still required?
6.6.2.3	Protection outside a licensee's frequency block	This requirement needs to be reviewed in content and application, since it is a regional requirement (FCC part 24.) The current text is based closely on FCC part 24. It may be possible to clarify the requirement (to allow more consistent testing) by including parameters which are specific to UTRA, including: <ul style="list-style-type: none"> <li>- defining requirement as an absolute value.</li> <li>- Defining the minimum carrier spacing from the edge of the licensee's frequency block.</li> <li>- Defining the -26dB bandwidth of the emission.</li> </ul> Defining the resolution bandwidth in the first 1MHz (the requirement would appear to be about 45kHz or greater; is it possible to perform this measurement with this value of resolution bandwidth?)
6.6.3.3.2	Co-existence with GSM 900; co-located base stations	Scenario calculations should be performed to confirm the requirement, currently -[98]dB.
6.6.3.4.2	Co-existence with DCS 1800; co-located base stations	Scenario calculations should be performed to confirm the requirement, currently -[98]dB.
6.8.2	Modulation accuracy	Further consideration is needed, especially for the multicode case.
6.8.3	Peak code domain error	The requirement is ffs.
7.1	General	Definition of requirements for antenna diversity is ffs.
7.3	Dynamic range	The requirement (BER/FER, value and channel type) is ffs. The effect of applying mast head LNAs to the dynamic range specification is ffs.
8	Performance requirement	Values are TBD. Requirements for BS without dual receiver diversity is ffs.
6 or 8	Transmit diversity	Specification text for SSDT requirement is needed, unclear in what section or possibly in TS 25.103.

## History

<b>Document history</b>		
<b>S4.01B</b> V0.0.1	1999-02-05	Merged document from (ARIB) Specification of Base Station for 3G Mobile System ver 1.0-0.1 and (ETSI) XX06v0.4.01 UTRA FDD; Radio transmission and reception (base station relevant parts).
V0.0.2	1999-02-16	Output from WG4 drafting session, with single base line text for most sections.
V0.0.3	1999-02-24	Editorial update after WG4#2 for distribution on the e-mail reflector.
V1.0.0	1999-03-04	Document status raised to v1.0.0 at TSG RAN#2. No editorial or content changes from v0.0.3 release apart from change to revision.
V1.0.1	1999-04-12	Incorporation of changes from WG4 #3, sent to e-mail reflector for comments.
<b>TS 25.104</b> V1.0.0	1999-04-22	Noted by TSG-RAN as TS 25.104 V1.0.0
V1.1.0	1999-06-04	Incorporation of changes from WG4 #4 in Kista, sent to the reflector for comments.
V1.2.0	1999-06-11	Incorporation of changes proposed on the reflector. Submitted to WG4 #5.
V2.0.0	1999-06-17	Output with changes from WG4 #5 in Miami, presented to RAN #4 in Miami.
V2.1.0	1999-06-23	Incorporation of changes approved at RAN #4 in Miami (harmonisation).
V2.2.0	1999-08-01	Incorporation of changes from WG4#6 in South Queensferry, sent to reflector in advance of WG4#7.
V2.3.0	1999-09-16	Incorporation of changes from WG4#7 in Makuhari, Japan. In addition several editorial changes and review of the Open Item list in Annex C.
V2.4.0	1999-10-03	Updated after the AH01 meeting in Noordwijkerhout on Performance Requirements. Sent to the reflector for comments in advance of TSG RAN #5.
V2.4.1	1999-10-06	A few editorial and open item updates. Presented to TSG RAN #5 for approval.
<p>Editor for TS 25.104 (UTRA (BS) FDD; Radio transmission and Reception) is:</p> <p>Johan Sköld Ericsson</p> <p>Tel: +46 (0) 8 757 23 92 Fax: +46 (0) 70 617 12 97 Email: <a href="mailto:johan.skold@era-t.ericsson.se">johan.skold@era-t.ericsson.se</a></p> <p>This document is written in Microsoft Word 7</p>		