

TSG-RAN meeting #3
Japan, 21th - 23th April 1999

TSG#3(99)230

Agenda Item:

Source: Editor

Title: S3.33: NBAP Specification

Document for:

3GPP

TS RAN S3.33 V0.1.0 (1999-04)

Technical Specification

**3rd Generation Partnership Project (3GPP);
Technical Specification Group (TSG) RAN
NBAP Specification**

[UMTS <spec>]

3GPP



Reference

<Workitem> (<Shortfilename>.PDF)

Keywords

<keyword[, keyword]>

3GPP

Postal address

Office address

Internet

secretariat@3gpp.org

Individual copies of this deliverable
can be downloaded from

<http://www.3gpp.org>

Copyright Notification

No part may be reproduced except as authorized by written permission.
The copyright and the foregoing restriction extend to reproduction in all media.

©
All rights reserved.

Contents

Intellectual Property Rights	5
Foreword	5
1 Scope	5
2 References	5
3 Definitions, symbols and abbreviations	5
3.1 Definitions.....	5
3.2 Symbols.....	6
3.3 Abbreviations.....	6
4 General.....	6
5 NBAP Services	6
6 Services expected from signalling transport.....	6
7 Functions of NBAP	6
8 Elementary NBAP procedures.....	6
9 Elements for NBAP communication	18
9.1 Message functional definition and content.....	18
9.2 Message format and information element coding	24
9.3 Timers	32 32
10 Handling of unknown, unforeseen and erroneous protocol data.....	32 32
11 Annex A (normative):.....	32 32
12 History	87 88

Intellectual Property Rights

Foreword

This Technical Specification has been produced by the 3rd Generation Partnership Project, Technical Specification Group <TSG name>.

The contents of this TS may be subject to continuing work within the 3GPP and may change following formal TSG approval. Should the TSG modify the contents of this TS, it will be re-released with an identifying change of release date and an increase in version number as follows:

Version m.t.e

where:

- m indicates [major version number]
- x the second digit is incremented for all changes of substance, i.e. technical enhancements, corrections, updates, etc.
- y the third digit is incremented when editorial only changes have been incorporated into the specification.

4 Scope

The present document ...

2 References

The following documents contain provisions which, through reference in this text, constitute provisions of the present document.

- References are either specific (identified by date of publication, edition number, version number, etc.) or non-specific.
- For a specific reference, subsequent revisions do not apply.
- For a non-specific reference, the latest version applies.
- A non-specific reference to an ETS shall also be taken to refer to later versions published as an EN with the same number.

[1]

[2]

3 Definitions, symbols and abbreviations

3.1 Definitions

For the purposes of the present document, the [following] terms and definitions [given in .and the following] apply.

<defined term>: <definition>.

example: text used to clarify abstract rules by applying them literally.

3.2 Symbols

For the purposes of the present document, the following symbols apply:

<symbol> <Explanation>

3.3 Abbreviations

<ACRONYM> <Explanation>

4 General

[Editor's note: This chapter should describe requirements on protocol capabilities, principles, etc.]

Node B Application protocol, NBAP, includes common procedures and dedicated procedures. It covers procedures for paging distribution, broadcast system information, request / complete / release of dedicated resources and management of logical resources.

Note that the issue of transport layer addressing is FFS.

5 NBAP Services

The NBAP offers the following services:

6 Services expected from signalling transport

7 Functions of NBAP

8 Elementary NBAP procedures

NBAP procedures are divided into common procedures and dedicated procedures.

- NBAP common procedures are procedures that request initiation of a UE context for a specific UE in Node B or are not related to a specific UE.

- NBAP dedicated procedures are procedures that are related to a specific UE context in Node B. This UE context is identified by a UE context identity.

The two types of procedures may be carried on separate signalling links.

8.1 NBAP Common Procedures

Note: Logical O&M Procedures will be included in this chapter.

8.1.1 Common Channels Management

This procedure provides the capability to activate common channel resources such as [cell broadcast channels and] random access channels. The ability to control, for example, paging retransmission should also be provided. Information on common channel performance (eg overload) should be provided by node B to the RNC.

8.1.2 Radio Resource Management

This procedure controls the physical radio system, eg transmitter tuning and output power control functions. Procedures [will], for example, also provide for the RNC to be informed of the automatic reconfiguration of node B in the case of partial failures and the availability of redundant radio equipment.

8.1.3 Iub Signalling Bearer Management

This procedure shall deal with the management of the Iub link. This will address not only initial link establishment, but also the ongoing monitoring of link health, link recovery, load sharing and distribution.

8.1.4 Measurement Request

For requesting measurements, the RNC use the following procedure:

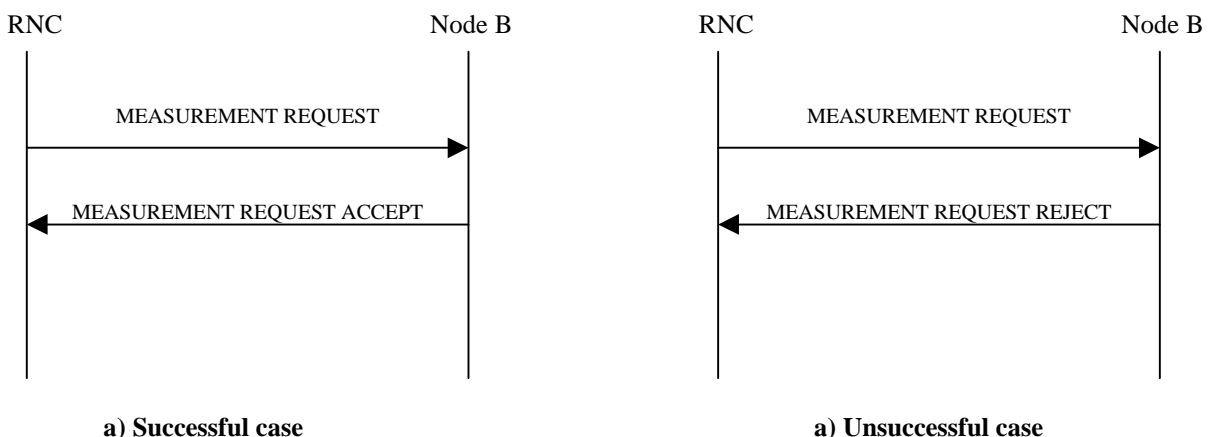

Measurement Request Procedure

The MEASUREMENT REQUEST message includes the following information:

- **Measurement Id:** This is a RNC defined identifier that uniquely identifies the measurement.
- **Measurement Object:** This defines on which resource the measurement should be performed. For example might this identifier point out a cell or a carrier within the Node B.

- **Measurement Type:** This defines what measurement that should be performed. This could for example be interference on the uplink”or tised power on the downlink”
- **Measurement Characteristics:** This defines how the measurements should be performed. For example measurement frequency, timing information, filtering information. *The exact structure and contents of this parameter is dependent on the Measurement Type and is FFS.*
- **Report Characteristics:** The reporting could be any of the following classes:
 - ◆ **Periodic:** Reports should be delivered in a periodic matter with some frequency. In this case the update frequency have to be specified.
 - ◆ **Event Triggered:** Reports should be delivered upon a specific event in Node B. In this case the event have to be specified.
 - ◆ **Immediate Reporting:** A report should be delivered immediately. Only one measurement report should be sent and after that the measurement is automatically cancelled.

The possibility to request several measurements for the same event is FFS.

The MEASUREMENT REQUEST ACCEPT message is used to accept a requested measurement and it includes the following information:

- **Measurement Id:** This is the same Id that was used in the request.

The MEASUREMENT REQUEST REJECT message is used to reject a requested measurement and it includes the following information:

- **Measurement Id:** This is the same Id that was used in the request.
- **Cause:** This states the cause for the reject. *The exact content of this parameter is FFS.*

8.4.5 Measurement Termination initiated by RNC

For termination of previously requested measurements, the RNC use the following procedure:

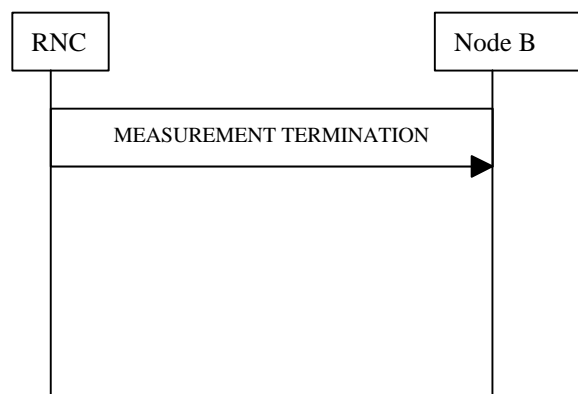

Measurement Termination Procedure initiated by RNC

The MEASUREMENT TERMINATION message includes the following information:

- **Measurement Id:** This is the same Id that was used in the request.

8.1.6 Measurement Termination initiated by NodeB

For termination of previously requested measurements from NodeB, the NodeB use the following procedure:

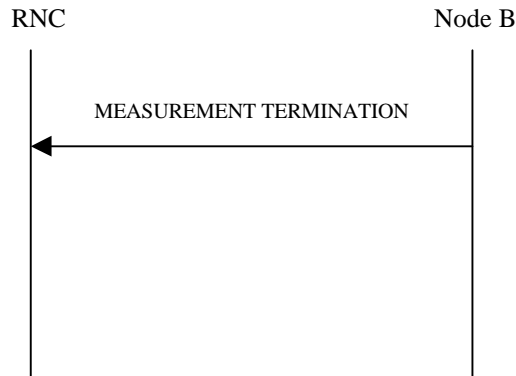

Measurement Termination Procedure initiated by NodeB

The MEASUREMENT TERMINATION message includes the following information:

- **Measurement Id:** This is the same Id that was used in the request.

8.1.7 Measurement Report

To report a previously requested measurement, Node B uses the following procedure:

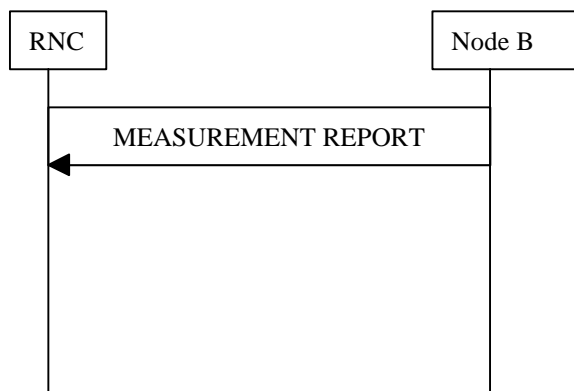

Measurement Report Procedure

The MEASUREMENT REPORT message includes the following information:

- **Measurement Id:** This is the same id that was used in the request.
- **Time Reference:** This is a time reference showing the time of the measurement. *The accuracy of this is FFS.*
- **Value**

The possibilities for including several values and/or several measurements in the same report are FFS.

8.1.8 Cell Configuration Management

This procedure provides the means for the RNC to configure some of the parameters of the node B and also the means for the node B to transfer the values of these and other parameters to the RNC. Examples are: RF parameters, system information parameters and, channel configuration data.

8.1.9 Notification of Available Logical Resources

When the resources of node B which are available to the RNC change (eg due to failures within Node B or due to interactions with OMC-B), this procedure provides the means to inform the RNC of this change and/or to warn the RNC of the impending change.

8.1.10 System Information Update Procedure

This NBAP common procedure is used by the CRNC to send system information to its Node B, which broadcasts them on the logical channel BCCH. The procedure is triggered when CRNC sets the system information at start/restart and when the system information needs to be modified.

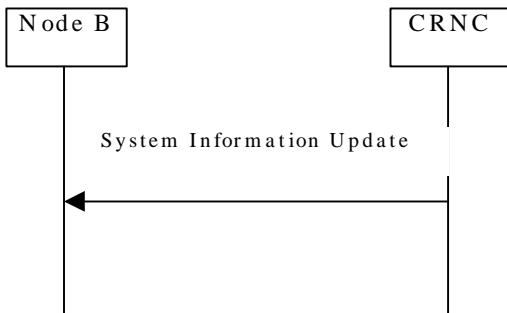

8.1.11 Radio Link Setup

This NBAP common procedure is used when there is no Radio Link for this UE in the Node B.

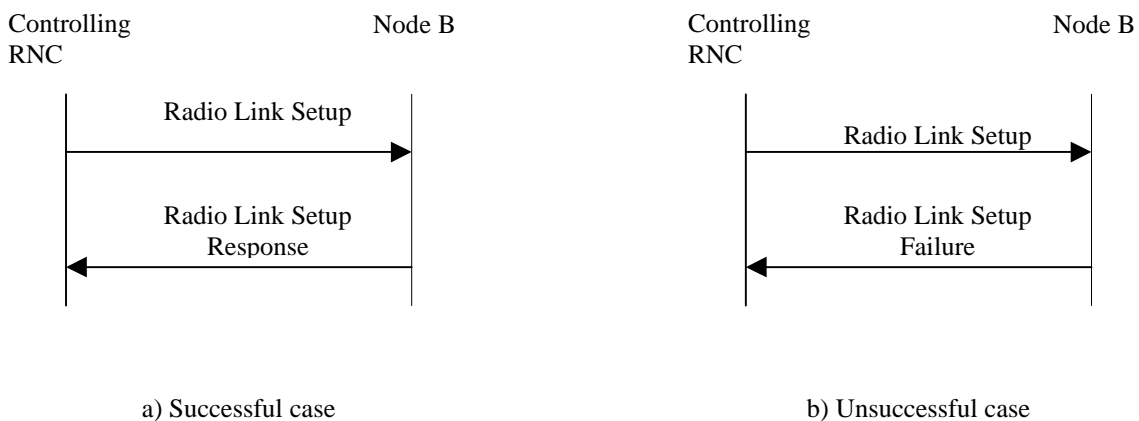

The RADIO LINK SETUP message contains the following information (the identification of the UE is FFS):

- UL Radio Resource (UL Scrambling Code, UL Channelisation Code)
- DL Radio Resource (DL Channelisation Codes per Radio Link, DL Scrambling Code is FFS)
- DCH Information (DCH Identifier, Transmission Rate, Transport Format Set) (for each DCH in the UE)
- Transport Format Combination Set
- Power control information
- Frequency
- RL identifier #1
- Target cell identifier #
- RL identifier #2
- Target cell identifier #
- Soft combining indication (may, must, or must not be combined with already existing radio links)
- ...
- RL identifier #n
- Target cell identifier #
- Soft combining indication (may, must, or must not be combined with already existing radio links)

The RADIO LINK SETUP RESPONSE message contains

- Transport layer addressing information (AAL2 address) per RL

8.1.12 Paging

Study item Iub/1: Which identity (e.g., location identity, URA id, or a list of cells) to use in order to know which cells to page is FFS.

This NBAP common procedure is used by the RNC to page UE which is in RRC idle state with UE identity; it is also used to page UE which is in URA connected state or cell connected state (PCH substate) with RNTI. This message also includes Location Identity or URA id or a list of cells (which method is being selected is FFS) for Node B to know which cell to page and an information for calculating the paging group.



8.2 NBAP Dedicated Procedures

8.2.1 Radio Link Addition

This procedure is used when there is already one or more existing Radio Link(s) for this UE in the Node B.

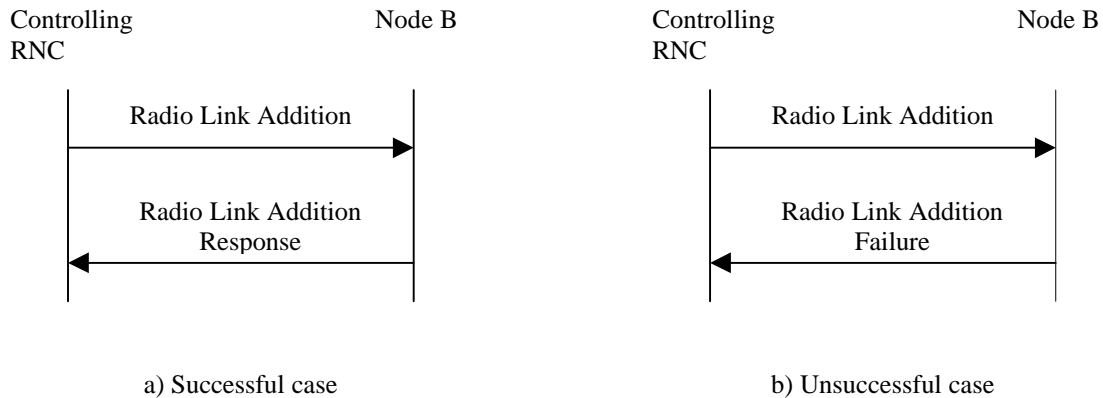

The RADIO LINK ADDITION message contains the following information (the identification of the UE is FFS):

- DL Radio Resource (DL channelisation codes) per RL
- Power control information
- the parameter OFF (frame offset information)
- Frequency
- RL identifier #n+1
- Target cell identifier #
- Soft combining indication (may, must, or must not be combined with already existing radio links)
- RL identifier #n+2
- Target cell identifier #
- Soft combining indication (may, must, or must not be combined with already existing radio links)
- ...

Other parameters are already known in the Node B, therefore there is no need to send them.

The RADIO LINK ADDITION RESPONSE message contains

- Transport layer addressing information (AAL2 address, AAL2 binding ID) per RL

If the transport layer addressing information is not needed in case Node B decides to use an existing AAL2 connection, then the AAL2 address is not needed and the AAL2 binding ID of the already existing AAL2 connection is sent. If the Controlling RNC receives the AAL2 binding ID of an already existing AAL2 connection, the Controlling

RNC does not execute the setting of the AAL2 connection.

8.2.2 Radio Link Reconfiguration (Synchronized)

The Radio Link Reconfiguration (Synchronized) procedure is used to reconfigure radio links related to one UE-UTRAN connection within Node B. The procedure can be used to add, delete or reconfigure a DCH. The Radio Link Reconfiguration procedure is initiated by the Controlling RNC by sending the message RADIO LINK RECONFIGURATION PREPARE to the Node B. The message is sent using the relevant signalling connection. It includes the desired radio link parameters for the radio links to be used continuously after completion of this procedure (no change in active set). If the proposed modifications are approved by the Node B resource management algorithms, and when the Node B has successfully reserved the required resources, it responds to the Controlling RNC with the RADIO LINK RECONFIGURATION READY message. In the unsuccessful case a NBAP message RADIO LINK RECONFIGURATION FAILURE is returned, indicating among other things the reason for failure. The Controlling RNC informs the UE about the changes in the RL with the relevant RRC message(s) after sending the RADIO LINK RECONFIGURATION COMMIT message to the Node Bs. If necessary (for example when the new L1/L2 configuration cannot coexist with the old one), the SRNC selects the most suitable CFN for the switching between the old and new configuration and includes it in the RRC message and in the RADIO LINK RECONFIGURATION COMMIT message. The Controlling RNC is responsible for releasing unnecessary Iub transport bearers (in case of DCH deletion).

This procedure is not used for adding or deleting radio links.

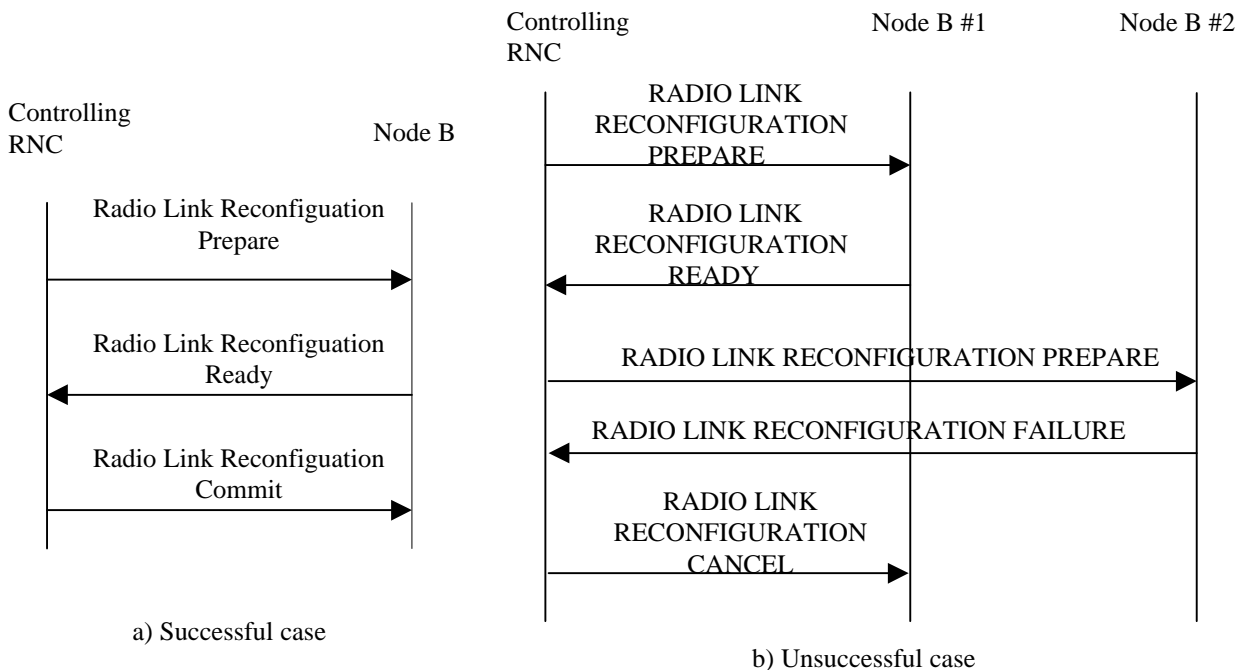

The RADIO LINK RECONFIGURATION PREPARE message contains:

- UL Radio Resources (UL Channelisation code type)
- DL Radio Resources (DL Channelisation code per RL) (if changed)
- Transport Format Combination Set

In case of DCH addition, this message also contains

- DCH Information (new DCH ID to add, Transmission Rate, Transport Format Set)
- Priority of DCH (How is it used?)

In case of DCH reconfiguration, this message also contains

- DCH Information (existing DCH ID to modify, Transmission Rate, Transport Format Set)
- Priority of modified DCH (How is it used?)

In case of DCH deletion, this message also contains

- DCH Information (DCH ID to delete)

The RADIO LINK RECONFIGURATION PREPARE message may consist of a combination of DCH addition, deletion, and reconfiguration.

The RADIO LINK RECONFIGURATION READY message contains:

- FFS

In case of DCH addition, this message also contains

- Transport layer addressing information (AAL2 address, AAL2 binding ID) for added DCH

In case of DCH reconfiguration, this message also contains

- Transport layer addressing information (AAL2 address, AAL2 binding ID) for modified DCH (if needed)

The RADIO LINK RECONFIGURATION FAILURE message contains

- CAUSE

The RADIO LINK RECONFIGURATION COMMIT message contains

- Timing information (e.g. CFN) to change old resource to new resource (FFS)

The RADIO LINK RECONFIGURATION CANCEL message contains

- Cancel information to reconfigure resources

Note: A mechanism for synchronising the switching from the old to the new configuration in the UE and in the Controlling RNC is needed and FFS.

8.2.3 Radio Link Reconfiguration (Unsynchronised)

The Radio Link Reconfiguration (Unsynchronised) procedure is used to reconfigure radio links related to one UE-UTRAN connection within Node B. The procedure can be used to add, delete or reconfigure a DCH.

The Unsynchronised RL Reconfiguration is used when there is no need to synchronise the time of the switching from the old to the new configuration in the node-Bs used by the UE-UTRAN connection. This is the case when new TFCs are added or old TFCs are deleted without changing the TFCI values of the TFCs that are maintained during the reconfiguration.

The Radio Link Reconfiguration procedure is initiated by the Controlling RNC by sending the message RADIO LINK RECONFIGURATION to the Node B. The message is sent using the relevant signalling connection. It includes the desired radio link parameters for the radio links to be used continuously after completion of this procedure (no change in active set).

If the proposed modifications are approved by the Node B resource management algorithms, and when the Node B has successfully reserved the required resources, it responds to the Controlling RNC with the RADIO LINK RECONFIGURATION RESPONSE message.

In the unsuccessful case a NBAP message RADIO LINK RECONFIGURATION FAILURE is returned, indicating among other things the reason for failure.

The Controlling RNC is responsible for releasing unnecessary Iub transport bearers (in case of DCH deletion).

This procedure is not used for adding or deleting radio links.

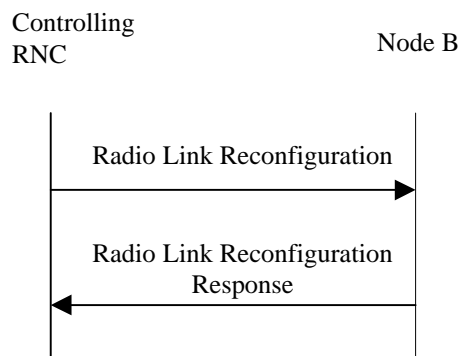

The RADIO LINK RECONFIGURATION message contains:

- Transport Format Combination Set

In case of DCH addition, this message also contains

- DCH Information (new DCH ID to add, Transmission Rate, Transport Format Set)
- Priority of DCH (How is it used?)

In case of DCH reconfiguration, this message also contains

- DCH Information (existing DCH ID to modify, Transmission Rate, Transport Format Set)
- Priority of modified DCH (How is it used?)

In case of DCH deletion, this message also contains

- DCH Information (DCH ID to delete)

The RADIO LINK RECONFIGURATION message may consist of a combination of DCH addition, deletion, and reconfiguration.

The RADIO LINK RECONFIGURATION RESPONSE message contains:

- FFS

In case of DCH addition, this message also contains

- Transport layer addressing information (AAL2 address, AAL2 binding ID) for added DCH

In case of DCH reconfiguration, this message also contains

- Transport layer addressing information (AAL2 address, AAL2 binding ID) for modified DCH (if needed)

The RADIO LINK RECONFIGURATION FAILURE message contains

- CAUSE

8.2.4 Radio Link Deletion

When the Controlling RNC is asked to delete a cell from the active set of a specific RRC connection, the message RADIO LINK DELETION is sent to the corresponding Node B. The message contains essentially the Radio Link identifier of the Radio Link to be deleted. Upon reception of the message, Node B should delete immediately the radio

link and all related allocations within the Node B and acknowledge the deletion to the Controlling RNC with the message RADIO LINK DELETION RESPONSE.

The Controlling RNC is responsible to release the corresponding Iub transport bearers if they are not used by other radio links.

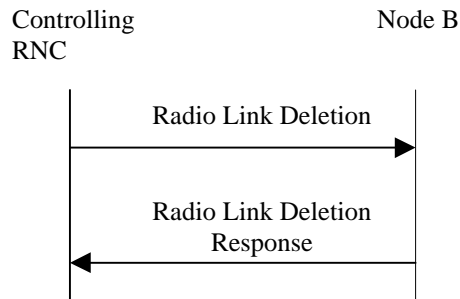

The RADIO LINK DELETION message contains (the identification of the UE is FFS):

- Radio Link Identifiers (of cells to be deleted)

The RADIO LINK DELETION RESPONSE message contains:

- FFS

8.2.5 DL Power Control

Note that this procedure is FFS. It is also FFS whether signalling is in-band or out-band.

The purpose of this procedure is to balance the DL transmission powers of Radio Links used for the related RRC connection within the node B. DL POWER CONTROL procedure is initiated by the Controlling RNC by sending a *DL POWER CONTROL* NBAP message, which contains the desired power range for the Radio Links within the node B.



8.2.6 Outer Loop Power Control

Note that there are four items that have to be solved.

First of all, this procedure itself is FFS.

It is also FFS assigned as "Study Item Iur/1" whether signalling is in-band or out-band since this study item is not only limited to Iur issue but also related to Iub issue.

Related to the item above, the third FFS item is by which DCH the DL Power Control signaling should be carried *if DL Power Control is performed in inband manner*.

The fourth FFS item is whether absolute or relative target SIR value is adopted as a parameter in DL Power Control signaling.

Note that the Eb/No range is not necessary in the signaling.

This procedure is used to provide the Node B with a new quality target value (Eb/I0) for the UL quality.



channelization code

9 Elements for NBAP communication

9.1 Message functional definition and content

Note that the content of this chapter is FFS.

This chapter defines the structure of the messages required for the NBAP protocols.

For each message there is, a table listing the signaling elements in their order of appearance in the transmitted message.

All the NBAP messages are listed in the following table:

[Note: All of these message names are tentative, these can be changed after complete discussion]

Message name	Reference
RADIO LINK SETUP	9.1.1
RADIO LINK SETUP RESPONSE	9.1.2
RADIO LINK SETUP FAILURE	9.1.3
RADIO LINK ADDITION	9.1.4
RADIO LINK ADDITION RESPONSE	9.1.5
RADIO LINK ADDITION FAILURE	9.1.6
RADIO LINK DELETION	9.1.7
RADIO LINK DELETION RESPONSE	9.1.8
RADIO LINK RECONFIGURATION PREPARE	9.1.9
RADIO LINK RECONFIGURATION READY	9.1.10
RADIO LINK RECONFIGURATION COMMIT	9.1.11
RADIO LINK RECONFIGURATION FAILURE	9.1.12

RADIO LINK RECONFIGURATION CANCEL	9.1.13
POWER CONTROL	9.1.15
OUTER LOOP POWER CONTROL	9.1.16
PAGING	9.1.17
RESET (FFS)	9.1.18
RESET ACKNOWLEDGE (FFS)	9.1.19
CONFUSION (FFS)	9.1.20

[Note: INFORMATION ELEMENT for each message shall be described in detail with each TYPE M/O.]

9.1.1 RADIO LINK SETUP

INFORMATION ELEMENT	REFERENCE	DIRECTION	TYPE	LEN
Link Reference		DRNC-NodeB	M	
Message Identifier			M	
Length			M	
Message Compatibility Information			M	
No. of DCHs			M	
DCH ID (# 1)			M	
TFS (for DCH ID# 1)			M	
DCH ID (# n)			M	
TFS (for DCH ID# n)			M	
TFCS (for DCHs)			M	
Radio Frequency			M	
UL scrambling code			M	
UL channelization code type			M	
No. of UL channelization code			M	
UL channelization code id(s)			M	
DL channelization code type			M	
No. of DL channelization code			M	
No. of Radio Links			M	
Radio Link ID			M	
Cell ID			M	
Phase Difference			M	
Radio Link ID			O	
Cell ID		O		
Soft Combination Indication		O		
Phase Difference		O		
Slot offset		M		
Frame offset		M		
Initial DL Power		M		
Target UL Eb/lo		M		

9.1.2 RADIO LINK SETUP RESPONSE

INFORMATION ELEMENT	REFERENCE	DIRECTION	TYPE	LEN
Link Reference		NodeB-DRNC	M	
Message Identifier			M	
Length			M	
Message Compatibility Information			M	
No. of DCHs			M	
DCH ID (# 1)			M	
ATM Binding ID			M	
ATM Address			O	
DCH ID (# n)			M	

ATM Binding ID			M	
ATM Address			O	
UL Interference Level			M	
No. of Radio Links			M	
Radio Link ID			M	
Neighbor Cell Information			M	
No. of DL channelization code			M	
DL channelization code id #1			M	
DL channelization code id #m			M	
Radio Link ID			O	
Neighbor Cell Information			O	
No. of DL channelization code			O	
DL channelization code id #1			O	
DL channelization code id #m			O	

9.1.3 RADIO LINK SETUP FAILURE

INFORMATION ELEMENT	REFERENCE	DIRECTION	TYPE	LEN
Link Reference		NodeB-DRNC	M	
Message Identifier			M	
Length			M	
Message Compatibility Information			M	
Cause			M	

9.1.4 RADIO LINK ADDITION

INFORMATION ELEMENT	REFERENCE	DIRECTION	TYPE	LEN
Link Reference		DRNC-NodeB	M	
Message Identifier			M	
Length			M	
Message Compatibility Information			M	
Radio Frequency			O	
No. of Radio Links			M	
Radio Link ID			M	
Cell ID			M	
Soft Combination Indication			M	
Phase Difference			M	
Radio Link ID			O	
Cell ID			O	
Soft Combination Indication			O	
Phase Difference			O	

9.1.5 RADIO LINK ADDITION RESPONSE

INFORMATION ELEMENT	REFERENCE	DIRECTION	TYPE	LEN
Link Reference		NodeB-DRNC	M	
Message Identifier			M	
Length			M	
Message Compatibility Information			M	
No. of DCHs			M	
DCH ID (# 1)			M	
ATM Binding ID			M	
ATM Address			O	
DCH ID (# n)			M	

ATM Binding ID			M	
ATM Address			O	
UL Interference Level			O	
No. of Radio Links			M	
Radio Link ID			M	
Neighbor Cell Information			M	
No. of DL channelization code			M	
DL channelization code id #1			M	
DL channelization code id #m			M	
Radio Link ID			O	
Neighbor Cell Information			O	
No. of DL channelization code			O	
DL channelization code id #1			O	
DL channelization code id #m			O	

9.1.6 RADIO LINK ADDITION FAILURE

INFORMATION ELEMENT	REFERENCE	DIRECTION	TYPE	LEN
Link Reference		NodeB-DRNC	M	
Message Identifier			M	
Length			M	
Message Compatibility Information			M	
Cause			M	

9.1.7 RADIO LINK DELETION

INFORMATION ELEMENT	REFERENCE	DIRECTION	TYPE	LEN
Link Reference		DRNC-NodeB	M	
Message Identifier			M	
Length			M	
Message Compatibility Information			M	
No. of Radio Links			M	
Radio Link ID #1			M	
Radio Link ID #2			O	

9.1.8 RADIO LINK DELETION RESPONSE

INFORMATION ELEMENT	REFERENCE	DIRECTION	TYPE	LEN
Link Reference		NodeB-DRNC	M	
Message Identifier			M	
Length			M	
Message Compatibility Information			M	

9.1.9 RADIO LINK RECONFIGURATION PREPARE

INFORMATION ELEMENT	REFERENCE	DIRECTION	TYPE	LEN
Link Reference		DRNC-NodeB	M	
Message Identifier			M	
Length			M	
Message Compatibility Information			M	
No. of DCHs			M	
DCH ID (# 1)		For Addition	M	
TFS (for DCH ID# 1)			O	

DCH QoS			M	
DCH ID (# n)			O	
TFS (for DCH ID# n)			O	
DCH QoS			O	
TFCS (for DCHs)		For Reconfiguration	M	
UL channelization code type			M	
No. of UL channelization code			M	
UL channelization code id(s)			M	
DL channelization code type			M	
No. of DL channelization code			M	
No. of Radio Links		For Deletion	M	
Radio Link ID#1			M	
Radio Link ID#2			O	

9.1.10 RADIO LINK RECONFIGURATION READY

INFORMATION ELEMENT	REFERENCE	DIRECTION	TYPE	LEN
Link Reference		NodeB-DRNC	M	
Message Identifier			M	
Length			M	
Message Compatibility Information			M	
No. of DCHs			O	
DCH ID (# 1)		For Addition	O	
ATM Binding ID			O	
ATM Address			O	
DCH ID (# n)			O	
ATM Binding ID			O	
ATM Address			O	
No. of Radio Links		For Reconfiguration	M	
Radio Link ID			M	
No. of DL channelization code			M	
DL channelization code id #1			M	
DL channelization code id #m		M		
Radio Link ID		For Deletion	O	
No. of DL channelization code			O	
DL channelization code id #1			O	
DL channelization code id #m			O	

9.1.11 RADIO LINK RECONFIGURATION COMMIT

INFORMATION ELEMENT	REFERENCE	DIRECTION	TYPE	LEN
Link Reference		DRNC-NodeB	M	
Message Identifier			M	
Length			M	
Message Compatibility Information			M	
Execution Time			M	

9.1.12 RADIO LINK RECONFIGURATION FAILURE

INFORMATION ELEMENT	REFERENCE	DIRECTION	TYPE	LEN
Link Reference		NodeB-DRNC	M	
Message Identifier			M	
Length			M	
Message Compatibility Information			M	

9.1.13 RADIO LINK RECONFIGURATION CANCEL

INFORMATION ELEMENT	REFERENCE	DIRECTION	TYPE	LEN
Link Reference		DRNC-NodeB	M	
Message Identifier			M	
Length			M	
Message Compatibility Information			M	

9.1.14 POWER CONTROL

INFORMATION ELEMENT	REFERENCE	DIRECTION	TYPE	LEN
Link Reference		DRNC-NodeB	M	
Message Identifier			M	
Length			M	
Message Compatibility Information			M	
DL Power Range			M	

9.1.15 OUTER LOOP POWER CONTROL

INFORMATION ELEMENT	REFERENCE	DIRECTION	TYPE	LEN
Link Reference		DRNC-NodeB	M	
Message Identifier			M	
Length			M	
Message Compatibility Information			M	
Target UL Eb/lo			M	

9.1.16 PAGING

INFORMATION ELEMENT	REFERENCE	DIRECTION	TYPE	LEN
Paged UE Identifier		DRNC-NodeB	M	
Link Reference			M	
Message Identifier			M	
Length			M	
LAI			M	
Group number of Incoming Call			M	

9.1.17 RESET (FFS)

9.1.18 RESET ACKNOWLEDGE (FFS)

9.1.19 CONFUSION (FFS)

9.2 Message format and information element coding

Note that the content of this chapter is FFS. Furthermore, it is also FFS whether to use abstract or explicit coding (see study item Iu/7).

This paragraph contains the CODING of the signaling elements used.

The following convention are assumed for the sequence of transmission of bits and bytes:

Each bit position is marked as 1 to 8. Bit 1 is the least significant bit and is transmitted first.

In an element octets are identified by number, octet 1 is transmitted first, then octet 2 etc.

Length Indicator

It is desirable to have Length for messages and parameters because future version of protocol may have extension to the present message or parameter, and also variable size can be present in some parameters as well.

In case of message size exceeding 256 byte it is better to have 2 bytes for message LENGTH.

However it is enough to have 1 byte for parameter LENGTH.

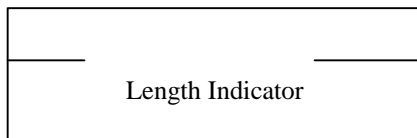

Fig. 9.2.4.1-1 Length Indicator for Message



Fig. 9.2.4.1-2 Length Indicator for Parameter

Compatibility Information

Compatibility Information is used in the situation of unrecognized messages or parameter. This parameter should be placed at a certain place then it is easy to pick up this parameter in any circumstances.

Consequently, the format can be as follow:

Message Identifier / Length / Compatibility Info / parameters

Parameter Identifier / Length / Compatibility Info / Fields

Figure 3 shows the coding format of message and Figure 4 shows the coding format of parameter.

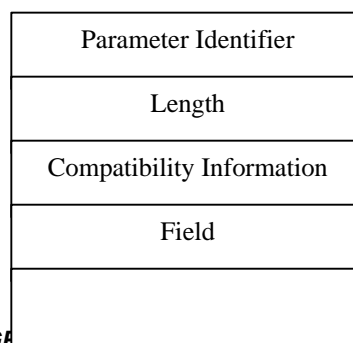
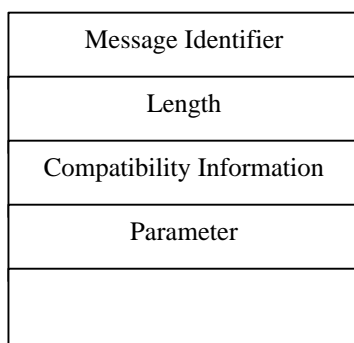

Fixed size data and Variable size data in Field

It may have two types of field i.e. with variable size or fixed size in data of field. It has no any problem to specify the fixed size field. Figure5 shows an example of fixed size data in field.

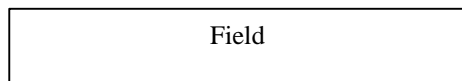

Fig. 9.2.4.1-5 Format for fixed size field

Regarding the variable size of data

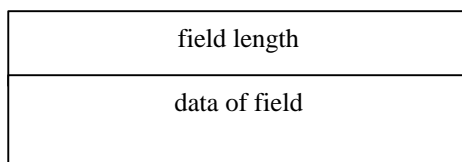

Fig. 9.2.4.1-6 Length method

The elements used and their CODING are:

Element Identifier Coding	Element name	Reference
	ATM Binding ID	
	ATM Address	
	No of DCHs	
	DCH ID	
	TFS(for DCH)	
	TFCS(for DCHs)	
	Radio Frequency	
	UL scrambling code	
	UL channelization code type	
	No. of UL channelization code	
	UL channelization code ID	
	UL Interference Level	
	DL channelization code type	
	No. of DL channelization code	
	DL channelization code id	
	Cell ID	
	Neighbor Cell Information	
	Soft Combination Indication	
	Phase Difference	
	Radio Link ID	
	No. of Radio Links	
	Execution Time	
	Slot offset	
	Frame offset	
	Initial DL Power	
	DL Power Range	
	Target UL Eb/lo	
	DCH QoS	
	LAI	
	Group number of incoming call	
	Cause	

9.2.1 Message Identifier

Message Identifier uniquely identifies the message being sent. It is a single octet element, mandatory in all messages.

8765 4321	
	RADIO LINK SETUP RADIO LINK SETUP RESPONSE RADIO LINK SETUP FAILURE
	RADIO LINK ADDITION RADIO LINK ADDITION RESPONSE RADIO LINK ADDITION FAILURE
	RADIO LINK DELETION RADIO LINK DELETION RESPONSE
	RADIO LINK RECONFIGURATION PREPARE RADIO LINK RECONFIGURATION READY RADIO LINK RECONFIGURATION COMMIT RADIO LINK RECONFIGURATION FAILURE RADIO LINK RECONFIGURATION CANCEL
	POWER CONTROL
	OUTER LOOP POWER CONTROL
	PAGING
	RESET (FFS)
	RESET ACKNOWLEDGE (FFS)

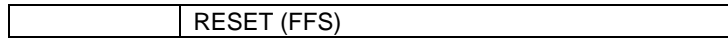

Message Compatibility Information

Message Compatibility Information is used in the situation of unrecognized messages.

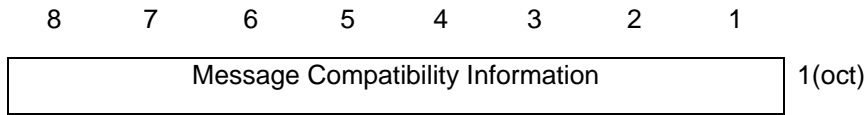

Figure: Message Compatibility Information

Table: Message Compatibility Information octet

Bit	
8	Reserved
:	
4	Pass On not possible
3	Discard Message
2	Send Notify (1)
1	Release Indicator

1. It should be used in CONFUSION message

9.2.2 Parameter Compatibility Information

Parameter Compatibility Information is used in the situation of unrecognized messages.

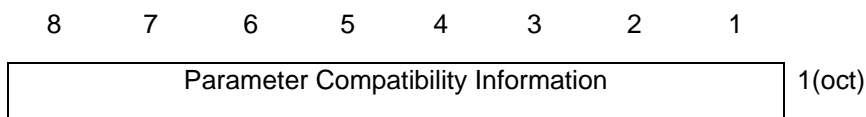

Figure: Parameter Compatibility Information

Table: Parameter Compatibility Information octet (The detail is FFS.)

Bit	
8	Reserved
:	
4	Pass On not possible
3	Discard Message
	Send Notify (1)



1. It should be used in CONFUSION message

9.2.3 ATM Address

This element is included ATM address.

[Note: The following should be described the coding format. (The detail is FFS.)]

9.2.4 ATM Binding ID

This element is included ATM Binding ID.

[Note: The following should be described the coding format. (The detail is FFS.)]

9.2.5 Cell ID

This element uniquely identifies cell which a RNC and is of variable length containing.

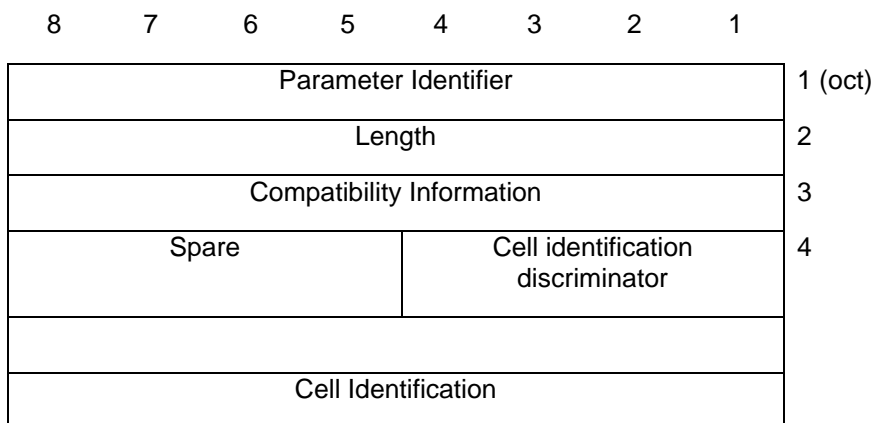

Figure: format of Cell Identifier

9.2.6 Neighbour Cell information

~~9.2.7~~No of DCHs

~~9.2.8~~DCH ID

~~9.2.9~~TFS(for DCH)

~~9.2.10~~TFCS(for DCHs)

~~9.2.11~~Soft Combination Indication

~~9.2.12~~Phase Difference

~~9.2.13~~Radio Frequency

~~9.2.14~~UL Interference level

~~9.2.15~~UL scrambling code

~~9.2.16~~UL channelization code type

~~9.2.17~~No. of UL channelization codes

~~9.2.18~~UL channelization code ID

~~9.2.19~~DL channelization code type

~~9.2.20~~No. of Radio Links

~~9.2.21~~ Radio Link ID

~~9.2.22~~ No. of DL channelization codes

~~9.2.23~~ DL channelization code ID

~~9.2.24~~ Execution Timer

~~9.2.25~~ Initial DL Power

~~9.2.26~~ DL Power Range

This Information element defines the DL transmission power range to be used for the radio links used for the related RRC connection in the node-B.

~~9.2.27~~ Target UL Eb/Io

~~9.2.28~~ Slot Offset

~~9.2.29~~ Frame Offset

~~9.2.30~~ DCH QoS

~~9.2.31~~ LAI

~~9.2.32~~ Group number of incoming call

~~9.2.33~~ Cause

This element is used to indicate the reason for a particular event to have occurred and is coded as shown below.

The cause value is a single octet element if the extension bit (bit 8) is set to 0. If it is set to 1 then the cause value is a 2octet field.

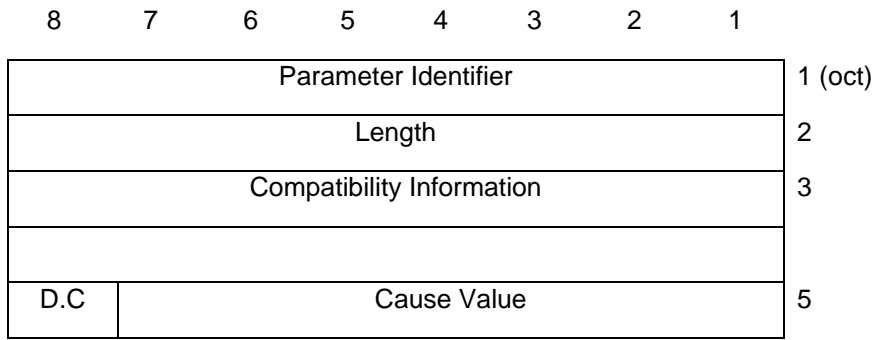

Figure: format of Cause

Cause Value:

Class: Normal event

Class: Normal event

Class: Resource unavailable

Class: Service or option not available

Class: Service or option not implemented

Class: invalid message (e.g. parameter out of range)

Class: protocol error

Class: interworking

The following table shows example of cause value.

Table: cause value

Cause Value		
Class	value	
<u>765</u>	<u>4321</u>	

		<p>Normal termination</p> <p>Mobile illegal (ex. Authentication NG)</p> <p>O & M intervention</p> <p>Equipment failure</p> <p>Protocol error</p> <p>Message type non-existent or not implemented</p> <p>Information element/parameter non-existent or not implemented</p> <p>Radio link failure</p> <p>BS approach link failure</p> <p>Timer expired</p> <p>Ciphering algorithm not supported</p> <p>Resource unavailable</p> <p>Other values are reserved</p>
--	--	--

~~9.3~~ Timers

~~10~~ Handling of unknown, unforeseen and erroneous protocol data

~~11~~ Annex A (normative):

12 ANNEX B: Iub Parameters List (Informative)

Note: The entire Annex is FFS.

Paging

Parameter Category	Iub Parameters	Iub Message	Note
		PAGING	
LAI	LAI	m	
Group No. of Incoming Call	Group No. of Incoming Call	m	

RRC Connection Setup

Parameter Category	Iub Parameters	Iub Message			Note
		IDLE to DCH			
		SETUP RADIO LINK	SETUP RADIO LINK	SETUP RADIO LINK	
Transport CH Info	No. of DCHs	m	-	-	
	DCH ID (# 1)	m	-	-	DCH ID or each DCH
	TFS (for DCH ID# 1)	m	-	-	Set TFS when it is required
	:				
	DCH ID (# n)	m	-	-	
	TFS (for DCH ID# n)	m	-	-	
	TFCS (for DCHs)	m	-	-	Set TFCS per UE
Transport Layer Addressing Information	No. of DCHs	-	m	-	
	DCH ID (# 1)	-	m	-	
	ATM Binding ID	-	m	-	(TTC) 1 Binding ID for 1 DCH *1
	ATM Address	-	o	-	
	:				
	DCH ID (# n)	-	m	-	
	ATM Binding ID	-	m	-	

3GPP

	ATM Address	-	o	-	
Radio Frequency Info	Radio Frequency	m	-	-	Set Radio Frequency per UE
	UL Interference Level	-	m	-	
UL Radio Resources	UL scrambling code	m	-	-	Set UL Scrambling Code per UE
	UL channelization code type	m	-	-	
	No. of UL channelization code	m	-	-	
	UL channelization code id(s)	m	-	-	
DL Radio Resources	DL channelization code type	m	-	-	Same code type for all Radio Links
	No. of DL channelization code	m	-	-	Same number of codes for all Radio Links
	No. of Radio Links	m	-	-	
	Radio Link ID	m	-	-	
	Cell ID	m	-	-	
	Soft Combination Indicator	-	-	-	Indicates May, Must, Must not
	Phase Difference	m	-	-	
	:				
	Radio Link ID	o	-	-	
	Cell ID	o	-	-	
	Soft Combination Indicator	o	-	-	

	Phase Difference	o	-	-	
DL Radio Resources	No. of Radio Links	-	m	-	
	Radio Link ID	-	m	-	
	Neighbor Cell Information	-	m	-	FFS*2
	No. of DL channelization code	-	m	-	
	DL channelization code id #1	-	m	-	
	:				
	DL channelization code id #m	-	m	-	
	:				
	Radio Link ID	-	o	-	
	Neighbor Cell Information	-	o	-	FFS
	No. of DL channelization code	-	o	-	
	DL channelization code id #1	-	o	-	
	:				
	DL channelization code id #m	-	o	-	
Execution Time	Execution Time	-	-	-	
Offset Values	Slot offset	m	-	-	
	Frame offset	m	-	-	

Power Control Info	Initial DL Power	m	-	-	For Initial DL Power Setting
	DL Power Range	-	-	-	For Correcting DL Power Drifting during DHO
Outerloop Power Control Info	Target UL Eb/lo	m	-	-	For L1 Power Control
Cause	Cause	-	-	m	

m: mandatory, o: optional

*1: In TTC assumption, in the case of intra RFTR RL addition in intra-frequency, it is always soft combined in RFTR. Also in the case of intra RFTR RL addition in inter-frequency, same lub ATM connection is used. Therefore, in case of RADIO LINK ADDITION resp.conf.(Inter RFTR), RFTR send existing binding ID to RACFd.

*2: Contents of this information is FFS. It is related to BS addressing scheme.

RAB Setup

Parameter Category	Iub Parameters	Iub Message										Note	
		RA/FACH to DCH			DCH to DCH						DCH to RA/FACH		
		SETUP	RADIO LINK SETUP	RADIO LINK SETUP	RADIO LINK RECONFIGURATION	RADIO LINK RECONFIGURATION	RADIO LINK RECONFIGURATION	RADIO LINK RECONFIGURATION	RADIO LINK RECONFIGURATION	RADIO LINK DELETION	RADIO LINK DELETION		
Transport CH Info	No. of DCHs	m	-	-	m	-	-	-	-	-	-	-	
	DCH ID (# 1)	m	-	-	m	-	-	-	-	-	-	-	DCH ID or each DCH
	TFS (for DCH ID# 1)	m	-	-	m	-	-	-	-	-	-	-	Set TFS when it is required

	:											
	DCH ID (# n)	m	-	-	m	-	-	-	-	-	-	
	TFS (for DCH ID# n)	m	-	-	m	-	-	-	-	-	-	
	TFCS (for DCHs)	m	-	-	m	-	-	-	-	-	-	Set TFCS per UE
Transport Layer	No. of DCHs	-	m	-	-	m	-	-	-	-	-	
Addressing Information	DCH ID (# 1)	-	m	-	-	m	-	-	-	-	-	
	ATM Binding ID	-	m	-	-	m	-	-	-	-	-	(TTC) 1 Binding ID for 1 DCH *1
	ATM Address	-	o	-	-	o	-	-	-	-	-	
	:											
	DCH ID (# n)	-	m	-	-	m	-	-	-	-	-	
	ATM Binding ID	-	m	-	-	m	-	-	-	-	-	
	ATM Address	-	o	-	-	o	-	-	-	-	-	
Radio Frequency Info	Radio Frequency	m	-	-	-	-	-	-	-	-	-	Set Radio Frequency per UE
	UL Interference Level	-	m	-	-	-	-	-	-	-	-	
UL Radio Resources	UL scrambling code	m	-	-	-	-	-	-	-	-	-	Set UL Scrambling Code per UE
	UL channelization code type	m	-	-	m	-	-	-	-	-	-	
	No. of UL channelization code	m	-	-	m	-	-	-	-	-	-	
	UL channelization code id(s)	m	-	-	m	-	-	-	-	-	-	

DL Radio Resources	DL channelization code type	m	-	-	m	-	-	-	-	-	-	Same code type for all Radio Links	
	No. of DL channelization code	m	-	-	m	-	-	-	-	-	-	Same number of codes for all Radio Links	
	No. of Radio Links	m	-	-	m	-	-	-	-	m	-		
	Radio Link ID	m	-	-	m	-	-	-	-	m	-		
	Cell ID	m	-	-	-	-	-	-	-	-	-		
	Soft Combination Indicator	-	-	-	-	-	-	-	-	-	-	Indicates May, Must, Must not	
	Phase Difference	m	-	-	-	-	-	-	-	-	-		
	:												
	Radio Link ID	o	-	-	o	-	-	-	-	-	o	-	
	Cell ID	o	-	-	-	-	-	-	-	-	-	-	
	Soft Combination Indicator	o	-	-	-	-	-	-	-	-	-	-	
	Phase Difference	o	-	-	-	-	-	-	-	-	-	-	
DL Radio Resources	No. of Radio Links	-	m	-	-	m	-	-	-	-	-		
	Radio Link ID	-	m	-	-	m	-	-	-	-	-		
	Neighbor Cell Information	-	m	-	-	-	-	-	-	-	-	FFS*2	
	No. of DL channelization code	-	m	-	-	m	-	-	-	-	-		
	DL channelization code id #1	-	m	-	-	m	-	-	-	-	-		
	:												

	DL channelization code id #m	-	m	-	-	m	-	-	-	-	-	
	:											
	Radio Link ID	-	o	-	-	o	-	-	-	-	-	
	Neighbor Cell Information	-	o	-	-	-	-	-	-	-	-	FFS
	No. of DL channelization code	-	o	-	-	o	-	-	-	-	-	
	DL channelization code id #1	-	o	-	-	o	-	-	-	-	-	
	:											
	DL channelization code id #m	-	o	-	-	o	-	-	-	-	-	
Execution Time	Execution Time	-	-	-	-	-	m	-	-	-	-	
Offset Values	Slot offset	m	-	-	-	-	-	-	-	-	-	
	Frame offset	m	-	-	-	-	-	-	-	-	-	
Power Control Info	Initial DL Power	m	-	-	-	-	-	-	-	-	-	For Initial DL Power Setting
	DL Power Range	-	-	-	-	-	-	-	-	-	-	For Correcting DL Power Drifting during DHO
Outerloop Power Control Info	Target UL Eb/lo	m	-	-	-	-	-	-	-	-	-	For L1 Power Control
Cause	Cause	-	-	m	-	-	-	m	-	-	-	

*1,*2: Same as the previous.

RAB Reconfiguration

Parameter Category	Iub Parameters	Iub Message					Note					
		DCH to DCH										
	PREPARE	ON	RADIO LINK READY RECONFIGURATI	ON	RADIO LINK COMMIT RECONFIGURATI	ON	RADIO LINK FAILURE RECONFIGURATI	ON	RADIO LINK CANCEL (FFS) RECONFIGURATI	ON	RECONFIGURATI	RADIO LINK
Transport CH Info	No. of DCHs	m	-	-	-	-						
	DCH ID (# 1)	m	-	-	-	-	DCH ID or each DCH					
	TFS (for DCH ID# 1)	m	-	-	-	-	Set TFS when it is required					
	:											
	DCH ID (# n)	m	-	-	-	-						
	TFS (for DCH ID# n)	m	-	-	-	-						
	TFCS (for DCHs)	m	-	-	-	-	Set TFCS per UE					
Transport Layer Addressing Information	No. of DCHs	-	m	-	-	-						
	DCH ID (# 1)	-	m	-	-	-						
	ATM Binding ID	-	m	-	-	-	(TTC) 1 Binding ID for 1 DCH *1					
	ATM Address	-	o	-	-	-						
	:											
	DCH ID (# n)	-	m	-	-	-						

	ATM Binding ID	-	m	-	-	-	
	ATM Address	-	o	-	-	-	
Radio Frequency Info	Radio Frequency	-	-	-	-	-	Set Radio Frequency per UE
	UL Interference Level	-	-	-	-	-	
UL Radio Resources	UL scrambling code	-	-	-	-	-	Set UL Scrambling Code per UE
	UL channelization code type	m	-	-	-	-	
	No. of UL channelization code	m	-	-	-	-	
	UL channelization code id(s)	m	-	-	-	-	
DL Radio Resources	DL channelization code type	m	-	-	-	-	Same code type for all Radio Links
	No. of DL channelization code	m	-	-	-	-	Same number of codes for all Radio Links
	No. of Radio Links	m	-	-	-	-	
	Radio Link ID	m	-	-	-	-	
	Cell ID	-	-	-	-	-	
	Soft Combination Indicator	-	-	-	-	-	Indicates May, Must, Must not
	Phase Difference	-	-	-	-	-	
	:						
	Radio Link ID	o	-	-	-	-	
	Cell ID	-	-	-	-	-	

	Soft Combination Indicator	-	-	-	-	-	
	Phase Difference	-	-	-	-	-	
DL Radio Resources	No. of Radio Links	-	m	-	-	-	
	Radio Link ID	-	m	-	-	-	
	Neighbor Cell Information	-	-	-	-	-	FFS*2
	No. of DL channelization code	-	m	-	-	-	
	DL channelization code id #1	-	m	-	-	-	
	:						
	DL channelization code id #m	-	m	-	-	-	
	:						
	Radio Link ID	-	o	-	-	-	
	Neighbor Cell Information	-	-	-	-	-	FFS
	No. of DL channelization code	-	o	-	-	-	
	DL channelization code id #1	-	o	-	-	-	
	:						
	DL channelization code id #m	-	o	-	-	-	
Execution Time	Execution Time	-	-	m	-	-	
Offset Values	Slot offset	-	-	-	-	-	

	Frame offset	-	-	-	-	-	
Power Control Info	Initial DL Power	-	-	-	-	-	For Initial DL Power Setting
	DL Power Range	-	-	-	-	-	For Correcting DL Power Drifting during DHO
Outerloop Power Control Info	Target UL Eb/lo	-	-	-	-	-	For L1 Power Control
Cause	Cause	-	-	-	m	-	

*1,*2: Same as the previous.

RAB Release

Parameter Category	Iub Parameters	Iub Message							Note
		DCH to DCH					DCH to RA/FACH		
		PREPARE	RADIO LINK READY RECONFIGURATIO	RADIO LINK COMMIT RECONFIGURATIO	RADIO LINK FAILURE RECONFIGURATIO	RADIO LINK CANCEL (FFS) RECONFIGURATIO	RADIO LINK RECONFIGURATIO	RESPONSE DELETION	
Transport CH Info	No. of DCHs	m	-	-	-	-	-	-	
	DCH ID (# 1)	m	-	-	-	-	-	-	DCH ID or each DCH
	TFS (for DCH ID# 1)	-	-	-	-	-	-	-	Set TFS when it is required
	:								
	DCH ID (# n)	m	-	-	-	-	-	-	
	TFS (for DCH ID# n)	-	-	-	-	-	-	-	
	TFCS (for DCHs)	m	-	-	-	-	-	-	Set TFCS per UE
Transport Layer Addressing Information	No. of DCHs	-	-	-	-	-	-	-	
	DCH ID (# 1)	-	-	-	-	-	-	-	
	ATM Binding ID	-	-	-	-	-	-	-	(TTC) 1 Binding ID for 1 DCH *1
	ATM Address	-	-	-	-	-	-	-	
	:								

	DCH ID (# n)	-	-	-	-	-	-	-	
	ATM Binding ID	-	-	-	-	-	-	-	
	ATM Address	-	-	-	-	-	-	-	
Radio Frequency Info	Radio Frequency	-	-	-	-	-	-	-	Set Radio Frequency per UE
	UL Interference Level	-	-	-	-	-	-	-	
UL Radio Resources	UL scrambling code	-	-	-	-	-	-	-	Set UL Scrambling Code per UE
	UL channelization code type	m	-	-	-	-	-	-	
	No. of UL channelization code	m	-	-	-	-	-	-	
	UL channelization code id(s)	m	-	-	-	-	-	-	
DL Radio Resources	DL channelization code type	m	-	-	-	-	-	-	Same code type for all Radio Links
	No. of DL channelization code	m	-	-	-	-	-	-	Same number of codes for all Radio Links
	No. of Radio Links	m	-	-	-	-	m	-	
	Radio Link ID	m	-	-	-	-	m	-	
	Cell ID	-	-	-	-	-	-	-	
	Soft Combination Indicator	-	-	-	-	-	-	-	Indicates May, Must, Must not
	Phase Difference	-	-	-	-	-	-	-	
	:								
Radio Link ID	o	-	-	-	-	o	-		

	Cell ID	-	-	-	-	-	-	-	
	Soft Combination Indicator	-	-	-	-	-	-	-	
	Phase Difference	-	-	-	-	-	-	-	
DL Radio Resources	No. of Radio Links	-	m	-	-	-	-	-	
	Radio Link ID	-	m	-	-	-	-	-	
	Neighbor Cell Information	-	-	-	-	-	-	-	FFS*2
	No. of DL channelization code	-	m	-	-	-	-	-	
	DL channelization code id #1	-	m	-	-	-	-	-	
	:								
	DL channelization code id #m	-	m	-	-	-	-	-	
	:								
	Radio Link ID	-	o	-	-	-	-	-	
	Neighbor Cell Information	-	-	-	-	-	-	-	FFS
	No. of DL channelization code	-	o	-	-	-	-	-	
	DL channelization code id #1	-	o	-	-	-	-	-	
	:								
DL channelization code id #m	-	o	-	-	-	-	-		
Execution Time	Execution Time	-	-	m	-	-	-	-	

Offset Values	Slot offset	-	-	-	-	-	-	-	
	Frame offset	-	-	-	-	-	-	-	
Power Control Info	Initial DL Power	-	-	-	-	-	-	-	For Initial DL Power Setting
	DL Power Range	-	-	-	-	-	-	-	For Correcting DL Power Drifting during DHO
Outerloop Power Control Info	Target UL Eb/lo	-	-	-	-	-	-	-	For L1 Power Control
Cause	Cause	-	-	-	m	-	-	-	

*1,*2: Same as the previous.

RRC Connection Release

Parameter Category	Iub Parameters	Iub Message		Note
		DCH to IDLE		
		DELETION	RADIO LINK DELETION	
Transport CH Info	No. of DCHs	-	-	
	DCH ID (# 1)	-	-	DCH ID or each DCH
	TFS (for DCH ID# 1)	-	-	Set TFS when it is required
	:			
	DCH ID (# n)	-	-	
	TFS (for DCH ID# n)	-	-	
	TFCS (for DCHs)	-	-	Set TFCS per UE
Transport Layer Addressing Information	No. of DCHs	-	-	
	DCH ID (# 1)	-	-	
	ATM Binding ID	-	-	(TTC) 1 Binding ID for 1 DCH *1
	ATM Address	-	-	
	:			
	DCH ID (# n)	-	-	
	ATM Binding ID	-	-	3GPP

	ATM Address	-	-	
Radio Frequency Info	Radio Frequency	-	-	Set Radio Frequency per UE
	UL Interference Level	-	-	
UL Radio Resources	UL scrambling code	-	-	Set UL Scrambling Code per UE
	UL channelization code type	-	-	
	No. of UL channelization code	-	-	
	UL channelization code id(s)	-	-	
DL Radio Resources	DL channelization code type	-	-	Same code type for all Radio Links
	No. of DL channelization code	-	-	Same number of codes for all Radio Links
	No. of Radio Links	m	-	
	Radio Link ID	m	-	
	Cell ID	-	-	
	Soft Combination Indicator	-	-	Indicates May, Must, Must not
	Phase Difference	-	-	
	:			
	Radio Link ID	o	-	
	Cell ID	-	-	
Soft Combination Indicator	-	-		
				3GPP

	Phase Difference	-	-	
DL Radio Resources	No. of Radio Links	-	-	
	Radio Link ID	-	-	
	Neighbor Cell Information	-	-	FFS*2
	No. of DL channelization code	-	-	
	DL channelization code id #1	-	-	
	:			
	DL channelization code id #m	-	-	
	:			
	Radio Link ID	-	-	
	Neighbor Cell Information	-	-	FFS
	No. of DL channelization code	-	-	
	DL channelization code id #1	-	-	
	:			
	DL channelization code id #m	-	-	
Execution Time	Execution Time	-	-	
Offset Values	Slot offset	-	-	
	Frame offset	-	-	

Power Control Info	Initial DL Power	-	-	For Initial DL Power Setting
	DL Power Range	-	-	For Correcting DL Power Drifting during DHO
Outerloop Power Control Info	Target UL Eb/lo	-	-	For L1 Power Control

*1,*2: Same as the previous.

Transport CH Reconfiguration

Parameter Category	Iub Parameters	Iub Message										Note	
		RA/FACH to DCH			DCH to DCH						DCH to RA/FACH		
		SETUP	RADIO LINK SETUP	RADIO LINK PREPARE	RADIO LINK READY RECONFIGURATION	RADIO LINK COMMIT RECONFIGURATION	RADIO LINK FAILURE RECONFIGURATION	RADIO LINK CANCEL (TFS) RECONFIGURATION	RECONFIGURATION	REPEITION	RADIO LINK DELETION		RADIO LINK
Transport CH Info	No. of DCHs	m	-	-	m	-	-	-	-	-	-	-	
	DCH ID (# 1)	m	-	-	m	-	-	-	-	-	-	-	DCH ID or each DCH
	TFS (for DCH ID# 1)	m	-	-	m	-	-	-	-	-	-	-	Set TFS when it is required
	:												
	DCH ID (# n)	m	-	-	m	-	-	-	-	-	-	-	
	TFS (for DCH ID# n)	m	-	-	m	-	-	-	-	-	-	-	
	TFCS (for DCHs)	m	-	-	m	-	-	-	-	-	-	-	Set TFCS per UE
Transport Layer	No. of DCHs	-	m	-	-	m	-	-	-	-	-	-	
Addressing Information	DCH ID (# 1)	-	m	-	-	m	-	-	-	-	-	-	
	ATM Binding ID	-	m	-	-	m	-	-	-	-	-	-	(TTC) 1 Binding ID for 1 DCH *1
	ATM Address	-	o	-	-	o	-	-	-	-	-	-	

	:											
	DCH ID (# n)	-	m	-	-	m	-	-	-	-	-	
	ATM Binding ID	-	m	-	-	m	-	-	-	-	-	
	ATM Address	-	o	-	-	o	-	-	-	-	-	
Radio Frequency Info	Radio Frequency	m	-	-	-	-	-	-	-	-	-	Set Radio Frequency per UE
	UL Interference Level	-	m	-	-	-	-	-	-	-	-	
UL Radio Resources	UL scrambling code	m	-	-	-	-	-	-	-	-	-	Set UL Scrambling Code per UE
	UL channelization code type	m	-	-	m	-	-	-	-	-	-	
	No. of UL channelization code	m	-	-	m	-	-	-	-	-	-	
	UL channelization code id(s)	m	-	-	m	-	-	-	-	-	-	
DL Radio Resources	DL channelization code type	m	-	-	m	-	-	-	-	-	-	Same code type for all Radio Links
	No. of DL channelization code	m	-	-	m	-	-	-	-	-	-	Same number of codes for all Radio Links
	No. of Radio Links	m	-	-	m	-	-	-	-	m	-	
	Radio Link ID	m	-	-	m	-	-	-	-	m	-	
	Cell ID	m	-	-	-	-	-	-	-	-	-	
	Soft Combination Indicator	-	-	-	-	-	-	-	-	-	-	Indicates May, Must, Must not
	Phase Difference	m	-	-	-	-	-	-	-	-	-	
	:											

	Radio Link ID	o	-	-	o	-	-	-	-	o	-	
	Cell ID	o	-	-	-	-	-	-	-	-	-	
	Soft Combination Indicator	o	-	-	-	-	-	-	-	-	-	
	Phase Difference	o	-	-	-	-	-	-	-	-	-	
DL Radio Resources	No. of Radio Links	-	m	-	-	m	-	-	-	-	-	
	Radio Link ID	-	m	-	-	m	-	-	-	-	-	
	Neighbor Cell Information	-	m	-	-	-	-	-	-	-	-	FFS*2
	No. of DL channelization code	-	m	-	-	m	-	-	-	-	-	
	DL channelization code id #1	-	m	-	-	m	-	-	-	-	-	
	:											
	DL channelization code id #m	-	m	-	-	m	-	-	-	-	-	
	:											
	Radio Link ID	-	o	-	-	o	-	-	-	-	-	
	Neighbor Cell Information	-	o	-	-	-	-	-	-	-	-	FFS
	No. of DL channelization code	-	o	-	-	o	-	-	-	-	-	
	DL channelization code id #1	-	o	-	-	o	-	-	-	-	-	
	:											
	DL channelization code id #m	-	o	-	-	o	-	-	-	-	-	

Execution Time	Execution Time	-	-	-	-	-	m	-	-	-	-	
Offset Values	Slot offset	m	-	-	-	-	-	-	-	-	-	
	Frame offset	m	-	-	-	-	-	-	-	-	-	
Power Control Info	Initial DL Power	m	-	-	-	-	-	-	-	-	-	For Initial DL Power Setting
	DL Power Range	-	-	-	-	-	-	-	-	-	-	For Correcting DL Power Drifting during DHO
Outerloop Power Control Info	Target UL Eb/lo	m	-	-	-	-	-	-	-	-	-	For L1 Power Control
Cause	Cause	-	-	m	-	-	-	m	-	-	-	

*1,*2: Same as the previous.

Physical CH Reconfiguration

Parameter Category	Iub Parameters	Iub Message										Note	
		RA/FACH to DCH			DCH to DCH						DCH to RA/FACH		
		SETUP	RADIO LINK SETUP	RADIO LINK SETUP	RADIO LINK RECONFIGURATION	RADIO LINK RECONFIGURATION	RADIO LINK RECONFIGURATION	RADIO LINK RECONFIGURATION	RADIO LINK RECONFIGURATION	RADIO LINK DELETION	RADIO LINK DELETION		
Transport CH Info	No. of DCHs	m	-	-	-	-	-	-	-	-	-	-	
	DCH ID (# 1)	m	-	-	-	-	-	-	-	-	-	-	DCH ID or each DCH
	TFS (for DCH ID# 1)	m	-	-	-	-	-	-	-	-	-	-	Set TFS when it is required
	:				-								
	DCH ID (# n)	m	-	-	-	-	-	-	-	-	-	-	
	TFS (for DCH ID# n)	m	-	-	-	-	-	-	-	-	-	-	
	TFCS (for DCHs)	m	-	-	-	-	-	-	-	-	-	-	Set TFCS per UE
Transport Layer Addressing Information	No. of DCHs	-	m	-	-	-	-	-	-	-	-	-	
	DCH ID (# 1)	-	m	-	-	-	-	-	-	-	-	-	
	ATM Binding ID	-	m	-	-	-	-	-	-	-	-	-	(TTC) 1 Binding ID for 1 DCH *1
	ATM Address	-	o	-	-	-	-	-	-	-	-	-	

	:												
	DCH ID (# n)	-	m	-	-	-	-	-	-	-	-		
	ATM Binding ID	-	m	-	-	-	-	-	-	-	-		
	ATM Address	-	o	-	-	-	-	-	-	-	-		
Radio Frequency Info	Radio Frequency	m	-	-	-	-	-	-	-	-	-	Set Radio Frequency per UE	
	UL Interference Level	-	m	-	-	-	-	-	-	-	-		
UL Radio Resources	UL scrambling code	m	-	-	o	-	-	-	-	-	-	Set UL Scrambling Code per UE	
	UL channelization code type	m	-	-	o	-	-	-	-	-	-		
	No. of UL channelization code	m	-	-	o	-	-	-	-	-	-		
	UL channelization code id(s)	m	-	-	o	-	-	-	-	-	-		
DL Radio Resources	DL channelization code type	m	-	-	o	-	-	-	-	-	-	Same code type for all Radio Links	
	No. of DL channelization code	m	-	-	o	-	-	-	-	-	-	Same number of codes for all Radio Links	
	No. of Radio Links	m	-	-	o	-	-	-	-	m	-		
	Radio Link ID	m	-	-	o	-	-	-	-	m	-		
	Cell ID	m	-	-	-	-	-	-	-	-	-		
	Soft Combination Indicator	-	-	-	-	-	-	-	-	-	-	-	Indicates May, Must, Must not
	Phase Difference	m	-	-	-	-	-	-	-	-	-		
	:												

	Radio Link ID	o	-	-	o	-	-	-	-	o	-	
	Cell ID	o	-	-	-	-	-	-	-	-	-	
	Soft Combination Indicator	o	-	-	-	-	-	-	-	-	-	
	Phase Difference	o	-	-	-	-	-	-	-	-	-	
DL Radio Resources	No. of Radio Links	-	m	-	-	m	-	-	-	-	-	
	Radio Link ID	-	m	-	-	m	-	-	-	-	-	
	Neighbor Cell Information	-	m	-	-	-	-	-	-	-	-	FFS*2
	No. of DL channelization code	-	m	-	-	m	-	-	-	-	-	
	DL channelization code id #1	-	m	-	-	m	-	-	-	-	-	
	:											
	DL channelization code id #m	-	m	-	-	m	-	-	-	-	-	
	:											
	Radio Link ID	-	o	-	-	o	-	-	-	-	-	
	Neighbor Cell Information	-	o	-	-	-	-	-	-	-	-	FFS
	No. of DL channelization code	-	o	-	-	o	-	-	-	-	-	
	DL channelization code id #1	-	o	-	-	o	-	-	-	-	-	
	:											
DL channelization code id #m	-	o	-	-	o	-	-	-	-	-		

Execution Time	Execution Time	-	-	-	-	-	m	-	-	-	-	
Offset Values	Slot offset	m	-	-	-	-	-	-	-	-	-	
	Frame offset	m	-	-	-	-	-	-	-	-	-	
Power Control Info	Initial DL Power	m	-	-	-	-	-	-	-	-	-	For Initial DL Power Setting
	DL Power Range	-	-	-	-	-	-	-	-	-	-	For Correcting DL Power Drifting during DHO
Outerloop Power Control Info	Target UL Eb/lo	m	-	-	-	-	-	-	-	-	-	For L1 Power Control
Cause	Cause	-	-	m	-	-	-	m	-	-	-	

*1,*2: Same as the previous.

Hard Handover (Inter-NodeB)

Parameter Category	Iub Parameters	Iub Message					Note
		RADIO LINK SETUP	RADIO LINK RESPONSE	RADIO LINK SETUP	RADIO LINK DELETION	RADIO LINK DELETION RESPONSE	
Transport CH Info	No. of DCHs	m	-	-	-	-	
	DCH ID (# 1)	m	-	-	-	-	DCH ID or each DCH
	TFS (for DCH ID# 1)	m	-	-	-	-	Set TFS when it is required
	:						
	DCH ID (# n)	m	-	-	-	-	
	TFS (for DCH ID# n)	m	-	-	-	-	
	TFCS (for DCHs)	m	-	-	-	-	Set TFCS per UE
Transport Layer Addressing Information	No. of DCHs	-	m	-	-	-	
	DCH ID (# 1)	-	m	-	-	-	
	ATM Binding ID	-	m	-	-	-	(TTC) 1 Binding ID for 1 DCH *1
	ATM Address	-	o	-	-	-	
	:						
	DCH ID (# n)	-	m	-	-	-	
	ATM Binding ID	-	m	-	-	-	
ATM Address	-	o	-	-	-		

Radio Frequency Info	Radio Frequency	m	-	-	-	-	Set Radio Frequency per UE
	UL Interference Level	-	m	-	-	-	
UL Radio Resources	UL scrambling code	m	-	-	-	-	Set UL Scrambling Code per UE
	UL channelization code type	m	-	-	-	-	
	No. of UL channelization code	m	-	-	-	-	
	UL channelization code id(s)	m	-	-	-	-	
DL Radio Resources	DL channelization code type	m	-	-	-	-	Same code type for all Radio Links
	No. of DL channelization code	m	-	-	-	-	Same number of codes for all Radio Links
	No. of Radio Links	m	-	-	m	-	
	Radio Link ID	m	-	-	m	-	
	Cell ID	m	-	-	-	-	
	Soft Combination Indicator	-	-	-	-	-	Indicates May, Must, Must not
	Phase Difference	m	-	-	-	-	
	:						
	Radio Link ID	o	-	-	o	-	
	Cell ID	o	-	-	-	-	
	Soft Combination Indicator	o	-	-	-	-	
	Phase Difference	o	-	-	-	-	

DL Radio Resources	No. of Radio Links	-	m	-	-	-	
	Radio Link ID	-	m	-	-	-	
	Neighbor Cell Information	-	m	-	-	-	FFS*2
	No. of DL channelization code	-	m	-	-	-	
	DL channelization code id #1	-	m	-	-	-	
	:						
	DL channelization code id #m	-	m	-	-	-	
	:						
	Radio Link ID	-	o	-	-	-	
	Neighbor Cell Information	-	o	-	-	-	FFS
	No. of DL channelization code	-	o	-	-	-	
	DL channelization code id #1	-	o	-	-	-	
	:						
	DL channelization code id #m	-	o	-	-	-	
Execution Time	Execution Time	-	-	-	-	-	
Offset Values	Slot offset	m	-	-	-	-	
	Frame offset	m	-	-	-	-	
Power Control Info	Initial DL Power	m	-	-	-	-	For Initial DL Power Setting

	DL Power Range	-	-	-	-	-	For Correcting DL Power Drifting during DHO
Outerloop Power Control Info	Target UL Eb/lo	m	-	-	-	-	For L1 Power Control
Cause	Cause	-	-	m	-	-	

*1,*2: Same as the previous.

Hard Handover (Intra-NodeB)

Parameter Category	Iub Parameters	Iub Message					Note
		ADDITION RESPONSE	ADDITION REQUEST	ADDITION RADIO LINK	DELETION RESPONSE	DELETION RADIO LINK	
Transport CH Info	No. of DCHs	-	-	-	-	-	
	DCH ID (# 1)	-	-	-	-	-	DCH ID or each DCH
	TFS (for DCH ID# 1)	-	-	-	-	-	Set TFS when it is required
	:						
	DCH ID (# n)	-	-	-	-	-	
	TFS (for DCH ID# n)	-	-	-	-	-	
	TFCS (for DCHs)	-	-	-	-	-	Set TFCS per UE
Transport Layer Addressing Information	No. of DCHs	-	m	-	-	-	
	DCH ID (# 1)	-	m	-	-	-	
	ATM Binding ID	-	m	-	-	-	(TTC) 1 Binding ID for 1 DCH *1
	ATM Address	-	o	-	-	-	
	:						
	DCH ID (# n)	-	m	-	-	-	
	ATM Binding ID	-	m	-	-	-	
ATM Address	-	o	-	-	-		

Radio Frequency Info	Radio Frequency	o	-	-	-	-	Set Radio Frequency per UE
	UL Interference Level	-	m	-	-	-	
UL Radio Resources	UL scrambling code	-	-	-	-	-	Set UL Scrambling Code per UE
	UL channelization code type	-	-	-	-	-	
	No. of UL channelization code	-	-	-	-	-	
	UL channelization code id(s)	-	-	-	-	-	
DL Radio Resources	DL channelization code type	-	-	-	-	-	Same code type for all Radio Links
	No. of DL channelization code	-	-	-	-	-	Same number of codes for all Radio Links
	No. of Radio Links	m	-	-	m	-	
	Radio Link ID	m	-	-	m	-	
	Cell ID	m	-	-	-	-	
	Soft Combination Indicator	m	-	-	-	-	Indicates May, Must, Must not
	Phase Difference	m	-	-	-	-	
	:						
	Radio Link ID	o	-	-	o	-	
	Cell ID	o	-	-	-	-	
	Soft Combination Indicator	o	-	-	-	-	
	Phase Difference	o	-	-	-	-	

DL Radio Resources	No. of Radio Links	-	m	-	-	-	
	Radio Link ID	-	m	-	-	-	
	Neighbor Cell Information	-	m	-	-	-	FFS*2
	No. of DL channelization code	-	m	-	-	-	
	DL channelization code id #1	-	m	-	-	-	
	:						
	DL channelization code id #m	-	m	-	-	-	
	:						
	Radio Link ID	-	o	-	-	-	
	Neighbor Cell Information	-	o	-	-	-	FFS
	No. of DL channelization code	-	o	-	-	-	
	DL channelization code id #1	-	o	-	-	-	
	:						
	DL channelization code id #m	-	o	-	-	-	
Execution Time	Execution Time	-	-	-	-	-	
Offset Values	Slot offset	-	-	-	-	-	
	Frame offset	-	-	-	-	-	
Power Control Info	Initial DL Power	-	-	-	-	-	For Initial DL Power Setting

	DL Power Range	-	-	-	-	-	For Correcting DL Power Drifting during DHO
Outerloop Power Control Info	Target UL Eb/lo	-	-	-	-	-	For L1 Power Control
Cause	Cause	-	-	m	-	-	

*1,*2: Same as the previous.

Handover Radio Link Addition (Inter-NodeB)

Parameter Category	Iub Parameters	Iub Message			Note
		SETUP RADIO LINK RESPONSE	SETUP RADIO LINK	SETUP RADIO LINK	
Transport CH Info	No. of DCHs	m	-	-	
	DCH ID (# 1)	m	-	-	DCH ID or each DCH
	TFS (for DCH ID# 1)	m	-	-	Set TFS when it is required
	:				
	DCH ID (# n)	m	-	-	
	TFS (for DCH ID# n)	m	-	-	
	TFCS (for DCHs)	m	-	-	Set TFCS per UE
Transport Layer Addressing Information	No. of DCHs	-	m	-	
	DCH ID (# 1)	-	m	-	
	ATM Binding ID	-	m	-	(TTC) 1 Binding ID for 1 DCH *1
	ATM Address	-	o	-	
	:				
	DCH ID (# n)	-	m	-	
	ATM Binding ID	-	m	-	
ATM Address	-	o	-		

Radio Frequency Info	Radio Frequency	m	-	-	Set Radio Frequency per UE
	UL Interference Level	-	m	-	
UL Radio Resources	UL scrambling code	m	-	-	Set UL Scrambling Code per UE
	UL channelization code type	m	-	-	
	No. of UL channelization code	m	-	-	
	UL channelization code id(s)	m	-	-	
DL Radio Resources	DL channelization code type	m	-	-	Same code type for all Radio Links
	No. of DL channelization code	m	-	-	Same number of codes for all Radio Links
	No. of Radio Links	m	-	-	
	Radio Link ID	m	-	-	
	Cell ID	m	-	-	
	Soft Combination Indicator	-	-	-	Indicates May, Must, Must not
	Phase Difference	m	-	-	
	:				
	Radio Link ID	o	-	-	
	Cell ID	o	-	-	
	Soft Combination Indicator	o	-	-	
	Phase Difference	o	-	-	

DL Radio Resources	No. of Radio Links	-	m	-	
	Radio Link ID	-	m	-	
	Neighbor Cell Information	-	m	-	FFS*2
	No. of DL channelization code	-	m	-	
	DL channelization code id #1	-	m	-	
	:				
	DL channelization code id #m	-	m	-	
	:				
	Radio Link ID	-	o	-	
	Neighbor Cell Information	-	o	-	FFS
	No. of DL channelization code	-	o	-	
	DL channelization code id #1	-	o	-	
	:				
	DL channelization code id #m	-	o	-	
Execution Time	Execution Time	-	-	-	
Offset Values	Slot offset	m	-	-	
	Frame offset	m	-	-	
Power Control Info	Initial DL Power	m	-	-	For Initial DL Power Setting

	DL Power Range	-	-	-	For Correcting DL Power Drifting during DHO
Outerloop Power Control Info	Target UL Eb/lo	m	-	-	For L1 Power Control
Cause	Cause	-	-	m	

*1,*2: Same as the previous.

Handover Radio Link Addition (Intra-NodeB)

Parameter Category	Iub Parameters	Iub Message			Note
		ADDI TION	RESPON SE	ADDI TION	
Transport CH Info	No. of DCHs	-	-	-	
	DCH ID (# 1)	-	-	-	DCH ID or each DCH
	TFS (for DCH ID# 1)	-	-	-	Set TFS when it is required
	:				
	DCH ID (# n)	-	-	-	
	TFS (for DCH ID# n)	-	-	-	
	TFCS (for DCHs)	-	-	-	Set TFCS per UE
Transport Layer Addressing Information	No. of DCHs	-	m	-	
	DCH ID (# 1)	-	m	-	
	ATM Binding ID	-	m	-	(TTC) 1 Binding ID for 1 DCH *1
	ATM Address	-	o	-	
	:				
	DCH ID (# n)	-	m	-	
	ATM Binding ID	-	m	-	
ATM Address	-	o	-		

Radio Frequency Info	Radio Frequency	o	-	-	Set Radio Frequency per UE
	UL Interference Level	-	m	-	
UL Radio Resources	UL scrambling code	-	-	-	Set UL Scrambling Code per UE
	UL channelization code type	-	-	-	
	No. of UL channelization code	-	-	-	
	UL channelization code id(s)	-	-	-	
DL Radio Resources	DL channelization code type	-	-	-	Same code type for all Radio Links
	No. of DL channelization code	-	-	-	Same number of codes for all Radio Links
	No. of Radio Links	m	-	-	
	Radio Link ID	m	-	-	
	Cell ID	m	-	-	
	Soft Combination Indicator	m	-	-	Indicates May, Must, Must not
	Phase Difference	m	-	-	
	:				
	Radio Link ID	o	-	-	
	Cell ID	o	-	-	
	Soft Combination Indicator	o	-	-	
	Phase Difference	o	-	-	

DL Radio Resources	No. of Radio Links	-	m	-	
	Radio Link ID	-	m	-	
	Neighbor Cell Information	-	m	-	FFS*2
	No. of DL channelization code	-	m	-	
	DL channelization code id #1	-	m	-	
	:				
	DL channelization code id #m	-	m	-	
	:				
	Radio Link ID	-	o	-	
	Neighbor Cell Information	-	o	-	FFS
	No. of DL channelization code	-	o	-	
	DL channelization code id #1	-	o	-	
	:				
	DL channelization code id #m	-	o	-	
Execution Time	Execution Time	-	-	-	
Offset Values	Slot offset	-	-	-	
	Frame offset	-	-	-	
Power Control Info	Initial DL Power	-	-	-	For Initial DL Power Setting

	DL Power Range	-	-	-	For Correcting DL Power Drifting during DHO
Outerloop Power Control Info	Target UL Eb/lo	-	-	-	For L1 Power Control
Cause	Cause	-	-	m	

*1,*2: Same as the previous.

Handover Radio Link Deletion (Inter-NodeB)

Parameter Category	Iub Parameters	Iub Message		Note
		DELETION RESPONSE	DELETION RADIO LINK	
Transport CH Info	No. of DCHs	-	-	
	DCH ID (# 1)	-	-	DCH ID or each DCH
	TFS (for DCH ID# 1)	-	-	Set TFS when it is required
	:			
	DCH ID (# n)	-	-	
	TFS (for DCH ID# n)	-	-	
	TFCS (for DCHs)	-	-	Set TFCS per UE
Transport Layer Addressing Information	No. of DCHs	-	-	
	DCH ID (# 1)	-	-	
	ATM Binding ID	-	-	(TTC) 1 Binding ID for 1 DCH *1
	ATM Address	-	-	
	:			
	DCH ID (# n)	-	-	
	ATM Binding ID	-	-	
ATM Address	-	-		

Radio Frequency Info	Radio Frequency	-	-	Set Radio Frequency per UE
	UL Interference Level	-	-	
UL Radio Resources	UL scrambling code	-	-	Set UL Scrambling Code per UE
	UL channelization code type	-	-	
	No. of UL channelization code	-	-	
	UL channelization code id(s)	-	-	
DL Radio Resources	DL channelization code type	-	-	Same code type for all Radio Links
	No. of DL channelization code	-	-	Same number of codes for all Radio Links
	No. of Radio Links	m	-	
	Radio Link ID	m	-	
	Cell ID	-	-	
	Soft Combination Indicator	-	-	Indicates May, Must, Must not
	Phase Difference	-	-	
	:			
	Radio Link ID	o	-	
	Cell ID	-	-	
	Soft Combination Indicator	-	-	
	Phase Difference	-	-	

DL Radio Resources	No. of Radio Links	-	-	
	Radio Link ID	-	-	
	Neighbor Cell Information	-	-	FFS*2
	No. of DL channelization code	-	-	
	DL channelization code id #1	-	-	
	:			
	DL channelization code id #m	-	-	
	:			
	Radio Link ID	-	-	
	Neighbor Cell Information	-	-	FFS
	No. of DL channelization code	-	-	
	DL channelization code id #1	-	-	
	:			
	DL channelization code id #m	-	-	
Execution Time	Execution Time	-	-	
Offset Values	Slot offset	-	-	
	Frame offset	-	-	
Power Control Info	Initial DL Power	-	-	For Initial DL Power Setting
3GPP				

[UMTS <spec>]

[TS RAN S3.33 V0.1.0 \(1999-04\)](#) | ~~[TS RAN S3.33 V0.1.0 \(1999-04\)](#)~~ | ~~[TS RAN S3.33 V0.01.20 \(1999-034\)](#)~~ |

	DL Power Range	-	-	For Correcting DL Power Drifting during DHO
Outerloop Power Control Info	Target UL Eb/lo	-	-	For L1 Power Control

*1,*2: Same as the previous.

Handover Radio Link Deletion (Intra-NodeB)

Parameter Category	Iub Parameters	Iub Message		Note
		DELETION RESPONSE	DELETION RADIO LINK	
Transport CH Info	No. of DCHs	-	-	
	DCH ID (# 1)	-	-	DCH ID or each DCH
	TFS (for DCH ID# 1)	-	-	Set TFS when it is required
	:			
	DCH ID (# n)	-	-	
	TFS (for DCH ID# n)	-	-	
	TFCS (for DCHs)	-	-	Set TFCS per UE
Transport Layer Addressing Information	No. of DCHs	-	-	
	DCH ID (# 1)	-	-	
	ATM Binding ID	-	-	(TTC) 1 Binding ID for 1 DCH *1
	ATM Address	-	-	
	:			
	DCH ID (# n)	-	-	
	ATM Binding ID	-	-	
ATM Address	-	-		

Radio Frequency Info	Radio Frequency	-	-	Set Radio Frequency per UE
	UL Interference Level	-	-	
UL Radio Resources	UL scrambling code	-	-	Set UL Scrambling Code per UE
	UL channelization code type	-	-	
	No. of UL channelization code	-	-	
	UL channelization code id(s)	-	-	
DL Radio Resources	DL channelization code type	-	-	Same code type for all Radio Links
	No. of DL channelization code	-	-	Same number of codes for all Radio Links
	No. of Radio Links	m	-	
	Radio Link ID	m	-	
	Cell ID	-	-	
	Soft Combination Indicator	-	-	Indicates May, Must, Must not
	Phase Difference	-	-	
	:			
	Radio Link ID	o	-	
	Cell ID	-	-	
	Soft Combination Indicator	-	-	
	Phase Difference	-	-	

DL Radio Resources	No. of Radio Links	-	-	
	Radio Link ID	-	-	
	Neighbor Cell Information	-	-	FFS*2
	No. of DL channelization code	-	-	
	DL channelization code id #1	-	-	
	:			
	DL channelization code id #m	-	-	
	:			
	Radio Link ID	-	-	
	Neighbor Cell Information	-	-	FFS
	No. of DL channelization code	-	-	
	DL channelization code id #1	-	-	
	:			
	DL channelization code id #m	-	-	
Execution Time	Execution Time	-	-	
Offset Values	Slot offset	-	-	
	Frame offset	-	-	
Power Control Info	Initial DL Power	-	-	For Initial DL Power Setting
3GPP				

[UMTS <spec>]

[TS RAN S3.33 V0.1.0 \(1999-04\)](#) | ~~[TS RAN S3.33 V0.1.0 \(1999-04\)](#)~~ | ~~[TS RAN S3.33 V0.01.20 \(1999-034\)](#)~~ |

	DL Power Range	-	-	For Correcting DL Power Drifting during DHO
Outerloop Power Control Info	Target UL Eb/Io	-	-	For L1 Power Control

*1,*2: Same as the previous.

Power Control

Parameter Category	Iub Parameters	Iub Message	Note
		POWER CONTROL	
Power Control Info	Initial DL Power	-	For Initial DL Power Setting
	DL Power Range	o	For Correcting DL Power Drifting during DHO

Outer-loop Power Control

Parameter Category	Iub Parameters	Iub Message	Note
		OUTER-LOOP POWER CONTROL	
Outerloop Power Control Info	Target UL Eb/lo	o	For L1 Power Control

13 History

Document history		
Edition x	<MMMM yyyy>	Publication as <old doctype> <old docnumber>
V0.0.1	March 1999	First Draft
V0.0.2	March 1999	Introduction of content from the Merged Description of I _{ub} Interface, V0.0.2 1999-03
V0.0.3	April 1999	<p>New sections 8.1.4. Measurement Request; 8.1.5. Measurement Termination requested by RNC; 8.1.6. Measurement Termination requested by NodeB; and 8.1.7. Measurement Report have been introduced. Contents in Tdoc R3-99191 have been reflected. Contents for Measurement Termination requested by NodeB will be contributed.</p> <p>New section 8.1.9. System Information Update Procedure has been introduced. Contents in Tdoc R99-192 have been reflected. Several corrections and modifications have been made to 4 General; 8.1.11 Paging; 8.2.2 Radio Link Reconfiguration (Synchronized); and 8.2.4 Radio Link Deletion reflecting the proposals in Tdoc R3-99193</p> <p>Editor's notes were added to 8.2.6 Outer Loop Power Control. The notes describe the raised discussion items to be solved from Tdoc R3-99176.</p> <p>8.2.7 Down Link Code Reconfiguration Trigger has been deleted according to the result of study item 'ARC/2: DL Channelization codes are managed and allocated by CRNC to NodeB'. 9.1.16 DL CODE RECONFIGURATION REQUEST has also been deleted.</p> <p>Spreading Code were renamed to Channelization Code</p> <p>Editor's notes were added onto the top of 8.1.1 stating that Logical O&M procedures would be included in NBAP Common Procedures</p>
V0.0.4	April 1999	New section 8.1.6 Measurement Termination initiated by NodeB has been added according to the result from TSG-RAN WG3 meeting #2. In accordance, the title of section 8.1.5 has been changed to 8.1.5 Measurement Termination initiated by RNC
V0.1.0	April 1999	V0.0.4 has been updated to V0.1.0 after the approval by TSG-RAN WG3
Editor for 3GPP RAN S3.33 is:		
Nobutaka Ishikawa NTT DoCoMo Tel.: +81 468 40 3220 Fax : +81 468 40 3840 Email : nobu@wsp.yrp.nttdocomo.co.jp		
This document is written in Microsoft Word 98.		