

1 **Title**

2 Proposed Changes to GERAN Stage-2 Description

3 **Source**

4 Lucent Technologies

5 **Abstract**

6 This contribution proposes changes to §§ 5.2 and 6.4.3.2 of the
7 GERAN stage-2 description.

8 **Recommendation**

9 Adopt the changes and incorporate in the latest version of the stage-2
10 description.

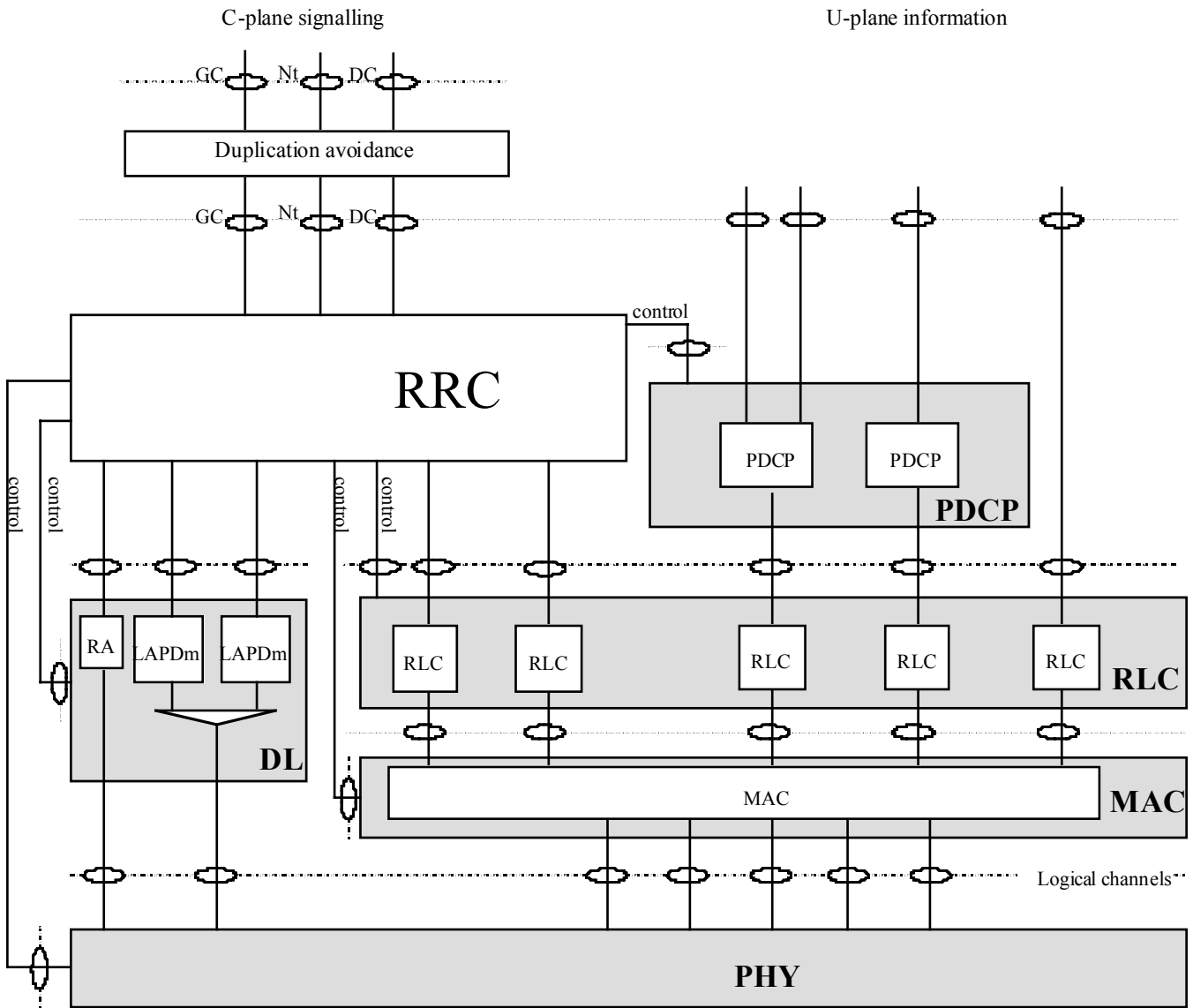

Figure 5. Radio Interface protocol architecture

Figure 5 reflects the radio interface protocol architecture as defined specifically in release 2000 connecting to the Iu interface.

5.2 Multiplexing Principles

5.2.1 Multiplexing of different types of radio access bearers

GERAN can allocate multiple dedicated and shared physical subchannels to a mobile station. The allocation shall be consistent with the mobile station's capability [11].

For a conversational class call, the GERAN offers the following multiplexing scenarios on the radio interface:

- **Operational Scenario 1.** Permanent allocation of a physical subchannel to a conversational class call, without any multiplexing capability.
- **Operational Scenario 2.** Permanent allocation of a physical subchannel to a conversational class call and multiplexing of best effort data from the same mobile station.

Different header adaptation mechanisms may be used by the PDCP:

- **Header compression.** Transport and network level headers (e.g. RTP/UDP/IP) are compressed in such a way that the decompressed headers are semantically identical to the original uncompressed headers. The IETF ROHC WG is responsible for standardising header compression schemes. Header compression is suited for standard internet applications that are not designed to work only with GERAN and especially for multimedia applications therefore the scheme will be used with generic realtime multimedia bearers.
- **Header removal.** Transport and network level headers (e.g. RTP/UDP/IP) headers are completely removed. Based on information submitted at call setup and based on information derived from lower layer (link & physical), the receiving entity can regenerate the headers. The primary application of header removal is the optimized speech bearer, and the regenerated header may not always be semantically identical to the original header.
- **No header adaptation.** Transport and network-level headers (e.g., RTP/UDP/IP) are forwarded.

6.5 Radio Link Control (RLC)

This section provides an overview on services and functions provided by the Radio Link Control (RLC). A detailed description of the RLC is given in [Ref: GERAN'00 RLC – 04.60 + ffs].

6.5.1 Services provided to upper layer

- **Transparent data transfer.** This service transmits higher layer PDUs without adding any protocol information.
- **Acknowledged data transfer.** This service transmits higher layer PDUs and guarantees delivery to the peer entity.
- **Unacknowledged data transfer.** This service transmits higher layer PDUs without guaranteeing delivery to the peer entity.
- **Notification of unrecoverable errors.** RLC notifies the upper layer of errors that cannot be resolved by RLC itself by normal exception handling procedures, e.g. by adjusting the maximum number of retransmissions according to delay requirements.

There is a single RLC connection per Radio Bearer.

6.5.2 RLC Functions

6.5.2.1 Transparent Mode

RLC has no functionality when operating in transparent mode. The incoming SDUs are transferred to the MAC layer without being altered. No upper layer protocol information is removed. No RLC protocol information is added. All necessary signalling is made out of band.

6.5.2.2 Non-Transparent Mode

In non transparent mode, the RLC is responsible for ciphering user data blocks (RLC PDUs). This function prevents unauthorized acquisition of data.

6.5.2.2.1 Acknowledged Mode

RLC has support for the following functions in acknowledged mode. For a detailed description, see GSM 04.60. In addition the RLC offers the possibility for adjusting the maximum number of retransmissions according to the delay requirements.

- **Segmentation** of upper layer PDUs into RLC data blocks.
- **Concatenation** of upper layer PDUs into RLC data blocks.
- **Padding** to fill out an RLC data block.