

Source: TSG CN WG3
Title: Transfer of information from TR23.910 “Tbd(TEI-6)”(Gq interface)
Agenda item: 9.22
Document for: APPROVAL

Introduction:

This document contains 1 CRs to **Transfer of information from TR23.910** that have been agreed by TSG CN WG3, and are forwarded to TSG CN Plenary for approval.

WG_tdoc	Spec	CR	R	Cat	Title	Rel	C_Ver	Work Item
N3-040885	29.007	106	2	B	Transfer of information from TR 23.910	Rel-6	5.10.0	[new WID]

3GPP TSG-CN WG3 Meeting #34

Tdoc #N3-040885

Seoul, Korea. 15th - 19th November 2004.

CR-Form-v7.1

CHANGE REQUEST

⌘ **29.007 CR 106** ⌘ rev **1** ⌘ Current version: **5.10.0** ⌘

For **HELP** on using this form, see bottom of this page or look at the pop-up text over the ⌘ symbols.

Proposed change affects: UICC apps ME Radio Access Network Core Network

Title:	⌘ Transfer of information from TR 23.910		
Source:	⌘ Siemens		
Work item code:	⌘	Date:	⌘ 08/11/2004
Category:	⌘ B	Release:	⌘ Rel-6
Use <u>one</u> of the following categories: F (correction) A (corresponds to a correction in an earlier release) B (addition of feature), C (functional modification of feature) D (editorial modification) Detailed explanations of the above categories can be found in 3GPP TR 21.900 .		Use <u>one</u> of the following releases: Ph2 (GSM Phase 2) R96 (Release 1996) R97 (Release 1997) R98 (Release 1998) R99 (Release 1999) Rel-4 (Release 4) Rel-5 (Release 5) Rel-6 (Release 6) Rel-7 (Release 7)	

Reason for change:	⌘ TR 23.910 is beeing converted to new TS 23.202 intended as stage 2 for CS data services. Thus references to the TR 23.910 contained in TS 29.007 need to be updated. Also, Stage-3 like information understood as normative used to be contained in TR 23.910 and better fits to the present spec Clause 11.6 is not restricted to Inter-MSC handover
Summary of change:	⌘ Clause 12 Transport protocols is introduced. Former Clause 11.6 is converted to new Clause 12.1 Transfer of former Clause 6 of TR 23.910 to new Clauses 12.2 and 12.2 Transfer of former Clause 10.1 of TR 23.910 to new Claus Clause 11.0 Update of former references to TR 23.910
Consequences if not approved:	⌘ TR 23.910 would need to be maintained in Rel-7. This TR would continue to contain information understood to be mandatory and a mixture of stage 2 and stage 3 level of detail.

Clauses affected:	⌘ 2, 9.2.3, 9.2.4, 10.2.3, 10.2.4, 11, new Clause 12										
Other specs affected:	<table border="1"> <tr> <td>Y</td> <td>N</td> </tr> <tr> <td>X</td> <td></td> </tr> <tr> <td></td> <td>X</td> </tr> <tr> <td></td> <td>X</td> </tr> </table>	Y	N	X			X		X	Other core specifications	⌘ New TS 23.202
Y	N										
X											
	X										
	X										
Other comments:	⌘										

2 References

The following documents contain provisions which, through reference in this text, constitute provisions of the present document.

- References are either specific (identified by date of publication, edition number, version number, etc.) or non-specific.
- For a specific reference, subsequent revisions do not apply.
- For a non-specific reference, the latest version applies. In the case of a reference to a 3GPP document (including a GSM document), a non-specific reference implicitly refers to the latest version of that document *in the same Release as the present document*.

- [1] ITU-T Recommendation G.711: "Pulse Code Modulation (PCM) of voice frequencies".
- [2] ITU-T Recommendation I.460: "Multiplexing, rate adaption and support of existing interfaces".
- [3] ITU-T Recommendation I.464: "Multiplexing, rate adaption and support of existing interfaces for restricted 64 kbit/s transfer capability".
- [4] ITU-T Recommendation Q.922 (1992): "DSS 1 Data link layer: ISDN data link layer specification for frame mode bearer services".
- [5] ITU-T Recommendation Q.931 (05/98): "DSS 1 - ISDN user network interface layer 3 specification for basic call control".
- [6] ITU-T Recommendation V.22: "1200 bits per second duplex modem standardized for use in the general switched telephone network and on point-to-point 2-wire leased telephone-type circuits".
- [7] ITU-T Recommendation V.24: "List of definitions for interchange circuits between data terminal equipment (DTE) and data circuit-terminating equipment (DCE)".
- [8] ITU-T Recommendation V.25: "Automatic answering equipment and general procedures for automatic calling equipment on the general switched telephone network including procedures for disabling of echo control devices for both manually and automatically established calls".
- [9] ITU-T Recommendation V.32: "A family of 2-wire, duplex modems operating at data signalling rates of up to 9600 bit/s for use on the general switched telephone network and on leased telephone-type circuits".
- [10] ITU-T Recommendation V.32bis: "A duplex modem operating at data signalling rates of up to 14 400 bit/s for use on the general switched telephone network and on leased point-to-point 2-wire telephone-type circuits".
- [11] ITU-T Recommendation V.34: "A modem operating at data signalling rates of up to 33 600 bit/s for use on the general switched telephone network and on leased point-to-point 2-wire telephone-type circuits".
- [12] ITU-T Recommendation V.42: "Error-correcting procedures for DCEs using asynchronous-to-synchronous conversion".
- [13] ITU-T Recommendation V.42bis: "Data compression procedures for Data Circuit Terminating Equipment (DCE) using error correction procedures".
- [14] ITU-T Recommendation V.90: "A digital modem and analogue modem pair for use on the Public Switched Telephone Network (PSTN) at data signalling rates of up to 56 000 bit/s downstream and up to 33 600 bit/s upstream".
- [15] ITU-T Recommendation V.110: "Support by an ISDN of data terminal equipments with V-Series type interfaces".
- [16] ITU-T Recommendation V.120: "Support by an ISDN of data terminal equipment with V-Series type interfaces with provision for statistical multiplexing".

- [17] ETSI ETR 018: "Integrated Services Digital Network (ISDN); Application of the Bearer Capability (BC), High Layer Compatibility (HLC) and Low Layer Compatibility (LLC) information elements by terminals supporting ISDN services".
- [18] ETSI ETS 300 102-1 Edition 1 (1990): "Integrated Services Digital Network (ISDN); User-network interface layer 3; Specifications for basic call control".
- [19] ETSI EN 300 403-1 V1.2.2 (1998-04): "Integrated Services Digital Network (ISDN); Digital Subscriber Signalling System No. one (DSS1) protocol; Signalling network layer for circuit-mode basic call control; Part 1: Protocol specification".
- [20] 3GPP TS 41.103: "GSM Release 5 specifications".
- [21] 3GPP TR 21.905: "Vocabulary for 3GPP specifications"
- [22] 3GPP TS 22.001: "Principles of circuit telecommunication services supported by a Public Land Mobile Network (PLMN)".
- [23] 3GPP TS 22.003: "Circuit teleservices supported by a Public Land Mobile Network (PLMN)".
- [24] 3GPP TS 43.010: " GSM Public Land Mobile Network (PLMN) connection types ".
- [25] 3GPP TS 43.045: "Technical realization of facsimile group 3 service - transparent".
- [26] 3GPP TS 43.050: "Transmission planning aspects of the speech service in the GSM Public Land Mobile Network (PLMN) system".
- [27] 3GPP TS 44.021: "Rate adaption on the Mobile Station - Base Station System (MS - BSS) interface".
- [28] 3GPP TS 48.020: "Rate adaption on the Base Station System - Mobile-services Switching Centre (BSS - MSC) interface".
- [29] 3GPP TS 48.060: "Inband control of remote transcoders and rate adaptors for full rate traffic channels".
- [30] 3GPP TS 09.02 : "Mobile Application Part (MAP) specification GSM Phase 1".
- [31] 3GPP TS 49.003: " Signalling requirements on interworking between the Integrated Services Digital Network (ISDN) or Public Switched Telephone Network (PSTN) and the Public Land Mobile Network (PLMN)".
- [32] 3GPP TS 21.103: "3rd Generation mobile system Release 5 specifications ".
- [33] 3GPP TS 22.002: "Circuit Bearer Services (BS) supported by a Public Land Mobile Network (PLMN)".
- [34] 3GPP TS 22.004: "General on supplementary services".
- [35] 3GPP TS 23.003: "Numbering, addressing and identification".
- [36] 3GPP TS 23.008: "Organization of subscriber data".
- [37] 3GPP TS 23.011: "Technical realization of supplementary services".
- [38] 3GPP TS 23.146: "Technical realization of facsimile group 3 non-transparent".
- [39] Void.
- [40] 3GPP TS 24.008: "Mobile radio interface layer 3 specification; Core network protocols; Stage 3".
- [41] 3GPP TS 24.022: "Radio Link Protocol (RLP) for circuit switched bearer and teleservices ".
- [42] 3GPP TS 25.415: "UTRAN Iu interface user plane protocols".
- [43] 3GPP TS 27.001: "General on Terminal Adaptation Functions (TAF) for Mobile Stations (MS)".

- [44] 3GPP TS 27.002: "Terminal Adaptation Functions (TAF) for services using Asynchronous bearer capabilities".
- [45] 3GPP TS 27.003: "Terminal Adaptation Functions (TAF) for services using Synchronous bearer capabilities".
- [46] 3GPP TS 29.002: "Mobile Application Part (MAP) specification".
- [47] 3GPP TS 24.002: "GSM - UMTS Public Land Mobile Network (PLMN) access reference configuration "
- [48] ISO/IEC 3309: "Information technology - Telecommunications and information exchange between systems - High-level Data Link Control (HDLC) procedures - Frame structure".
- [49] IETF RFC 1662: "PPP in HDLC-like framing".
- [50] Mobile Internet Access Forum: "PIAFS Specification Ver. 1.1, 2.1".
- [51] ITU-T Recommendation V.8: "Procedures for starting sessions of data transmission over the public switched telephone network".
- [52] 3GPP TS 26.111: "Codec for circuit switched multimedia telephony service; Modifications to H.324".
- [53] ~~3GPP TR 23.910: "Circuit switched data bearer services"~~. [Void](#)
- [54] ITU-T Recommendation H.223: "Multiplexing protocol for low bit rate multimedia communication".
- [55] ITU-T Recommendation H.223 (Annex A): "Multiplexing protocol for low bit rate multimedia communication over low error-prone channels".
- [56] ITU-T Recommendation H.223 (Annex B): "Multiplexing protocol for low bit rate multimedia communication over moderate error-prone channels".
- [57] ITU-T Recommendation H.223 (Annex C): "Multiplexing protocol for low bit rate multimedia communication over highly error-prone channels".
- [58] ITU-T Recommendation H.324: "Terminal for low bit-rate multimedia communication".
- [59] ITU-T Recommendation H.221: "Frame structure for a 64 to 1920 kbit/s channel in audiovisual teleservices".
- [60] ITU-T Recommendation H.242: "System for establishing communication between audiovisual terminals using digital channels up to 2 Mbit/s".
- [61] ITU-T Recommendation H.245: "Control protocol for multimedia communication".
- [62] ITU-T Recommendation V.8 bis: "Procedures for the identification and selection of common modes of operation between data circuit-terminating equipments (DCEs) and between data terminal equipments (DTEs) over the public switched telephone network and on leased point-to-point telephone-type circuits".
- [63] ITU-T Recommendation V.21: "300 bits per second duplex modem standardized for use in the general switched telephone network".
- [64] ITU-T Recommendation V.22bis (1988): "2400 bits per second duplex modem using the frequency division technique standardized for use on the general switched telephone network and on point-to-point 2-wire leased telephone-type circuits".
- [65] ITU-T Recommendation V.23: "600/1200-baud modem standardized for use in the general switched telephone network".
- [66] ITU-T Recommendation V.26: "2400 bits per second modem standardized for use on 4-wire leased telephone-type circuits".

- [67] ITU-T Recommendation V.26 bis: "2400/1200 bits per second modem standardized for use in the general switched telephone network".
- [68] ITU-T Recommendation V.26 ter: "2400 bits per second duplex modem using the echo cancellation technique standardized for use on the general switched telephone network and on point-to-point 2-wire leased telephone-type circuits".
- [69] ITU-T Recommendation V.27: "4800 bits per second modem with manual equalizer standardized for use on leased telephone-type circuits".
- [70] ITU-T Recommendation V.27 bis: "4800/2400 bits per second modem with automatic equalizer standardized for use on leased telephone-type circuits".
- [71] ITU-T Recommendation V.29: "9 600 bits per second modem standardized for use on point-to-point 4-wire leased telephone-type circuits".
- [72] ITU-T Recommendation Q.921: "ISDN user-network interface - Data link layer specification".
- [73] ITU-T Recommendation X.21: "Interface between Data Terminal Equipment (DTE) and Data Circuit-terminating Equipment (DCE) for synchronous operation on public data networks".
- [74] ITU-T Recommendation X.25: "Interface between Data Terminal Equipment (DTE) and Data Circuit - terminating Equipment (DCE) for terminals operating in the packet mode and connected to public data networks by dedicated circuit".
- [75] ITU-T Recommendation X.28: "DTE/DCE interface for a start-stop mode Data Terminal Equipment accessing the Packet Assembly/Disassembly facility (PAD) in a public data network situated in the same country".
- [76] ITU-T Recommendation X.31: "Support of packet mode terminal equipment by an ISDN".
- [77] ITU-T Recommendation X.75: "Packet-switched signalling system between public networks providing data transmission services".
- [78] ISO 2110: "Information technology - Data communication - 25-pole DTE/DCE interface connector and contact number assignments".
- [79] ISO/IEC 6429: "Information technology - Control functions for coded character sets".
- [80] 3GPP TS 29.415: "Core Network Nb Interface User Plane Protocols"
- [81] ITU-T Recommendation I.366.2: "AAL type 2 service specific convergence sublayer for trunking".
- [82] 3GPP TS 29.232: "Media Gateway Controller (MGC); Media Gateway (MGW) interface; Stage 3"
- [83] 3GPP TS 23.172: "Technical Realisation of the Circuit Switched (CS) multimedia service; UDI/RDI fallback and service modification; Stage 2"
- [84] ITU-T Recommendation E.163: "Numbering plan for the international telephone service".
- [85] ITU-T Recommendation E.164: "The international public telecommunication numbering plan".
- [86] [3GPP TS 27.001: "General on Terminal Adaption Functions \(TAF\) for Mobile Station \(MS\)".](#)
- [87] [ITU-T Recommendation I.363.2: "B-ISDN ATM Adaptation Layer specification : Type 2 AAL".](#)
- [88] [ITU-T Recommendation I.366.2: "AAL type 2 service specific convergence sublayer for narrow-band services".](#)
- [89] [ITU-T Recommendation Q.2630.1: "AAL type 2 signalling protocol \(Capability Set 1\)".](#)
- [90] [3GPP TS 23.202: " Circuit switched data bearer services".](#)

Next modified Section

9.2.3 Transparent service support

The protocol stacks for transparent services are specified in 3GPP TS 43.010 and in [Clause 12.23](#)~~3GPP TR 23.910~~.

In Iu mode, the transparent services are based in the Iu User Plane protocol specified in 3GPP TS 25.415.
 In A/Gb mode the rate adaptation scheme shall be utilized on the RAN to MSC link as identified in 3GPP TS 48.020. The transcoding function will generate the 64 kbit/s rate adapted format utilizing the 8 and 16 kbit/s intermediate data rates. The MSC to MSC/IWF link (e.g. in the case of handover) will utilize the same 64 kbit/s rate adaptation scheme as that indicated in 3GPP TS 48.020.

For the transparent service support the MSC/IWF will select the modem and speed based on the Compatibility information contained in either the call set-up or call confirmed message reference subclauses 9.2.1 and 9.2.2. Where the modem type indicated is one of the multi-speed versions, e.g. V.32, then the MSC/IWF will restrict the modem to the speed indicated in the call set-up and call confirmed message, respectively, i.e. will inhibit the modem from changing speed, irrespective of the conditions, error rate, encountered on the PSTN link. This scenario is also applicable for the use of "autobauding" modems, in that only the specifically requested modem type and speed will be selected at the MSC/IWF (however Facsimile Group 3 can use channel mode modify).

9.2.3.1 Structure of the MSC/IWF for Iu mode

The transmission towards the RNC is based on AAL2. The Iu UP is used in the transparent mode.

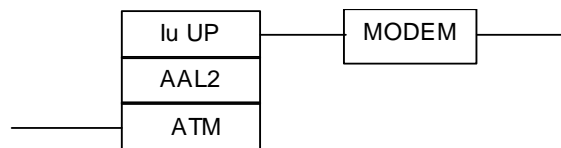

Figure 4: Structure of MSC/IWF

Next modified Section

9.2.3.3 Mapping of signalling UE/MSC/IWF to modem interface requirements

This process also is a reverse of the function provided in the Terminal Adaptation function of the UE for the mapping of DTE/DCE signalling information to Dm channel and in band signalling information. See 3GPP TS 27.002 and 3GPP TS 27.003.

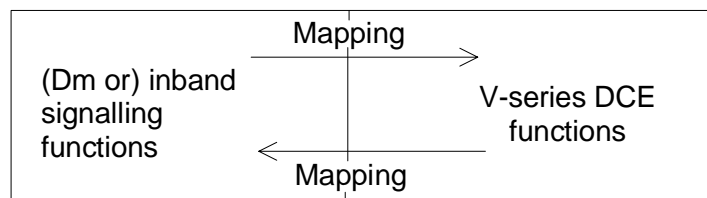

Figure 6: Signalling mapping schematic

Status bits SA, SB and X can be used to convey channel control information associated with the data bits in the data transfer state. Table 5 shows the mapping scheme between the V.24 circuit numbers corresponding to the V-series DCE functions and the status bits for the transparent mode. It also shows how the unused status bits should be handled. It is derived from the General Mapping scheme described in annex B. A binary 0 corresponds to the ON condition, a binary 1 to the OFF condition.

The transport of these status bits by the various channel codings is described in 3GPP TS 44.021 and 3GPP TS 48.020 for A/Gb mode. For Iu mode refer to [3GPP Clause 12](#)~~TR 23.910~~.

NOTE Although the interface to the modem is described in terms of V.24 interchange circuit functions, this does not imply that such circuits need to be physically realised.

Table 5: Mapping scheme at the IWF for the transparent mode

Mapping direction: UE to IWF	Mapping direction: IWF to UE	Signal at IWF modem interface or condition within the IWF
always ON (note 1)		CT 105
	to status bit X	CT 106
	not mapped (note 5)	CT 107
not mapped (note 6)		CT 108
	to status bit SB	CT 109
always ON (note 2)		CT 133
from status bit SA (note 3)		ignored by IWF
from status bit SB (note 1)		ignored by IWF
from status bit X (note 4)		ignored by IWF
	to status bit SA (note 3)	always ON
<p>NOTE 1: The SB bit towards the IWF, according to the General Mapping (annex B), could be used to carry CT 105 from the mobile DTE to the modem in the IWF. However, CT 105 should always be ON at the DTE interface in the data transfer state since only duplex operation is supported. Also, many DTEs use the connector pin assigned to CT 105 for CT 133. Therefore, CT 105 shall always be set to ON at the IWF modem during the data transfer state.</p> <p>NOTE 2: CT 133 is not mapped since there is no flow control in transparent mode.</p> <p>NOTE 3: The SA bits in both directions are available only with certain channel codings. Therefore, for maximum compatibility, they should not be mapped.</p> <p>NOTE 4: The X bit towards the IWF is not mapped since there is no flow control in transparent mode.</p> <p>NOTE 5: CT 107 is not used by the IWF.</p> <p>NOTE 6: CT 108 is used in the call setup and answering processes.</p>		

In general it is not required for the modem in the MSC/IWF to support a "remote looping" request from a modem in the PSTN. In addition the invocation of a "remote looping" request from the mobile subscriber to a modem in the PSTN need not be supported (see also 3GPP TS 27.001). Specific test loops for mobile subscribers to contact may be provided at the network operators discretion.

Next modified Section

9.2.4 Non-transparent service support

The protocol stacks for non-transparent services are specified in 3GPP TS 43.010 and in [3GPP-Clause 12.3, TR-23.910](#). Both of the systems use the Radio Link Protocol (RLP) specified in 3GPP TS 24.022.

In Iu mode, the non-transparent services are based in the Iu User Plane protocol specified in 3GPP TS 25.415.

In A/Gb mode the corresponding necessary support concerning the rate adaptation scheme shall be utilized on the RAN-MSC link as identified in 3GPP TS 48.020.

For the non-transparent service support the MSC/IWF will select the modem and speed based on the Compatibility information contained in either the call set-up or call confirmed message, reference subclauses 9.2.1 and 9.2.2. Where the Modem Type indicated is autobaoding type 1, the MSC/IWF may select any speed and modem type according to what it can negotiate with the remote modem. In this case User Rate and Fixed Network User Rate, if present, has no meaning.

Next modified Section

10.2.3 Transparent service support

The protocol stacks for transparent services are specified in 3GPP TS 43.010 and in [3GPP-~~Clause 12.2~~.~~TR-23.910~~](#).

In Iu mode, the transparent services are based in the Iu User Plane protocol specified in 3GPP TS 25.415.

In A/Gb mode identifies the rate adaptation scheme shall be utilized on the RAN to MSC link as identified in 3GPP TS 48.020. The transcoding function will generate the 64 kbit/s rate adapted format utilizing the 8 and 16 kbit/s intermediate data rates. The MSC - MSC/IWF will utilize the same rate adaptation scheme as that indicated in 3GPP TS 48.020, i.e. adapted to 64 kbit/s.

Next modified Section

10.2.3.3 Mapping of signalling UE/MSC/IWF to modem or ISDN (V.110) TA-function interface requirements

For the 3,1 kHz audio interworking case see subclause 9.2.3.3.

Status bits SA, SB and X can be used to convey channel control information associated with the data bits in the data transfer state. Table 8 shows the mapping scheme between the V.24 circuit numbers corresponding to the V-series DCE functions and the status bits for the transparent mode. It also shows how the unused status bits should be handled. It is derived from the General Mapping scheme described in annex B. A binary 0 corresponds to the ON condition, a binary 1 to the OFF condition.

The transport of these status bits by the various channel codings is described in 3GPP TS 44.021 and 48.020 for A/Gb mode. For Iu mode refer to 3GPP [Clause 12](#).~~TR-23.910~~.

NOTE Although the interface to the ISDN TA function is described in terms of V.24 interchange circuit functions, this does not imply that such circuits need to be physically realised.

Table 8: Mapping scheme at the IWF for the transparent mode

Mapping direction: UE to IWF	Mapping direction: IWF to UE	Signal at IWF ISDN TA interface or condition within the IWF
always ON (note 1)		CT 105
	to status bit X	CT 106
	not mapped (note 5)	CT 107
not mapped (note 6)		CT 108
	to status bit SB	CT 109
always ON (note 2)		CT 133
from status bit SA (note 3)		ignored by IWF
from status bit SB (note 1)		ignored by IWF
from status bit X (note 4)		ignored by IWF
	to status bit SA (note 3)	always ON
NOTE 1: The SB bit towards the IWF, according to the General Mapping (annex B), could be used to carry CT 105 from the mobile DTE to the ISDN TA function in the IWF. However, CT 105 should always be ON at the DTE interface in the data transfer state since only duplex operation is supported. Also, many DTEs use the connector pin assigned to CT 105 for CT 133. Therefore, CT 105 shall always be set to ON at the IWF ISDN TA function during the data transfer state.		
NOTE 2: CT 133 is not mapped since there is no flow control in transparent mode.		
NOTE 3: The SA bits in both directions are available only with certain channel codings. Therefore, for maximum compatibility, they should not be mapped.		
NOTE 4: The X bit towards the IWF is not mapped since there is no flow control in transparent mode.		
NOTE 5: CT 107 is not used by the IWF.		
NOTE 6: CT 108 is used in the call setup and answering processes.		

Next modified Section

10.2.4 Non-transparent service support

The protocol stacks for non-transparent services are specified in 3GPP TS 43.010 and in [Clause 12.2](#)~~3GPP TR 23.910~~. Both of the systems use the Radio Link Protocol (RLP) specified in 3GPP TS 24.022.

In Iu mode, the non-transparent services are based in the Iu User Plane protocol specified in 3GPP TS 25.415.

In A/Gb mode the corresponding necessary support concerning the rate adaptation scheme shall be utilized on the RAN-MSC link as identified in 3GPP TS 48.020.

For the non-transparent service support the MSC/IWF will select the modem and speed based on the Compatibility information contained in either the call set-up or call confirmed message, reference subclauses 9.2.1 and 9.2.2. Where the Modem Type indicated is autobauding type 1, the MSC/IWF may select any speed and modem type according to what it can negotiate with the remote modem. In this case User Rate and Fixed Network User Rate, if present, has no meaning.

Next modified Section

10.2.4.3 Re-constitution of user data

3GPP TS 24.022 refers to the frame of user data in the radio link protocol. The layer 2 relay functions in the UE and the MSC/IWF (identified in 3GPP TS 43.010 and ~~3GPP TR 23.910~~ [TS 23.202 \[90\]](#)) contain the mechanism for packing and unpacking the user data into the L2R protocol data units.

Next modified Section

11 Interworking between A/Gb mode MSC and Iu mode MSC

11.0 Signalling issues

11.0.1 Loss of BC Information during Handover from A/Gb mode to UTRAN Iu mode

In the case of inter-MSC handover from A/Gb mode to UTRAN Iu mode, the serving A/Gb mode MSC/VLR sends a MAP message Prepare Handover carrying the BSSMAP message Handover Request. This message includes the parameter Channel Type, indicating whether radio resources are to be allocated for speech or data (parameter 'Speech or data indicator') and, among other data, the type of data service (transparent/non transparent) and the user rates (both included in the parameter 'Data rate and transparency indicator').

As no other bearer capability related parameters are received, it is not possible to distinguish between any other services than 'speech', 'data transparent' and 'data non-transparent'.

The mapping into QoS radio access parameters would be done as described in 3GPP TS 27.001[86], annex B, subclause B.1.13., limited to the services 'speech', 'data, non-transparent' and 'data, transparent'.

11.0.2 Handover from UTRAN Iu mode to A/Gb mode

In case a UTRAN Iu mode call is set up in the CN, the BC IE parameters are mapped into QoS RAB parameters at call setup.

If the CN has to perform a handover towards A/Gb mode, the non-anchor MSC needs to perform an assignment based on GSM traffic channel parameters.

In case of handover from UTRAN Iu mode to A/Gb mode, the anchor MSC maps the BC IE parameters into A/Gb mode traffic channel parameters. This requires that the BC IE is coded according to A/Gb mode protocol requirements, i.e. all those parameters ignored in UTRAN Iu mode should nevertheless be correctly specified by the UE in order to perform a handover to A/Gb mode.

11.0.3 Loss of BC Information during Handover from A/Gb mode to GERAN Iu mode

Subclause 11.0.1 applies also to handover from A/Gb mode to GERAN Iu mode.

Additionally, the serving A/Gb mode MSC/VLR will include the parameter GERAN Classmark in the MAP message

Prepare Handover, if this parameter is available. The GERAN Classmark, which indicates the capabilities of the BSS in the target cell (e.g. allowed channel codings and maximum number of traffic channels), shall be taken into account by the target MSC when it performs the mapping into QoS radio access parameters.

11.0.4 Handover from GERAN Iu mode to A/Gb mode

Subclause 10.1.2 applies also to handover from GERAN Iu mode to A/Gb mode.

NOTE: The protocol requirements for the coding of the BC IE according to GERAN Iu mode are the same as for A/Gb mode, i.e. all those parameters needed in order to perform a handover to A/Gb mode are available.

11.0.5 Handover from UTRAN Iu mode to GERAN Iu mode

The serving UTRAN Iu mode MSC/VLR will send a MAP message Prepare Handover carrying the RANAP message Relocation Request. When setting the QoS RAB parameters in the RANAP message Relocation Request, the serving UTRAN Iu mode MSC/VLR shall take into account:

- the GERAN Classmark of the target cell, if this parameter is available;
- the allowed channel codings and the maximum number of traffic channels from the BC IE, if the serving MSC is the anchor MSC; and
- the allowed radio interface rates (included in the parameter Channel Type), if the serving MSC is not the anchor MSC.

This requires that the BC IE is coded according to GERAN Iu mode protocol requirements, i.e. all those parameters ignored in UTRAN Iu mode should nevertheless be correctly specified by the UE in order to perform a handover to GERAN Iu mode. Furthermore, it requires that the anchor MSC maps the BC IE parameters into A/Gb mode traffic channel parameters and includes the parameter Channel Type in the MAP message Prepare Handover also for basic handover to UTRAN Iu mode.

11.0.6 Handover from GERAN Iu mode to UTRAN Iu mode

The serving GERAN Iu mode MSC/VLR will send a MAP message Prepare Handover carrying the RANAP message Relocation Request. When setting the QoS RAB parameters in the RANAP message Relocation Request, the serving GERAN Iu mode MSC/VLR shall take the mode of the target cell into account. (See 3GPP TS 27.001[86], annex B, subclause B.1.13. For non-transparent services, some of the RAB Subflow Combination bit rates are supported in GERAN Iu mode, but not in UTRAN Iu mode.)

11.1 Handover from Iu mode MSC to A/Gb mode MSC

After a handover from an Iu mode MSC to an A/Gb mode MSC the user plane between the anchor MSC and the visited MSC shall comply to the standard A-interface protocols, i.e.:

- A-TRAU or modified V.110 frames as defined in 3GPP TS 44.021 [27] and 3GPP TS 48.020 [28];
- up to four 16kbit/s substreams are multiplexed in one 64kbit/s channel (Split/Combine function and Multiplexing function as defined in 3GPP TS 44.021 [27] and 3GPP TS 48.020 [28]).

Next modified Section

11.4 Handover within Iu mode PLMNs

After a handover from an Iu mode MSC to a UTRAN Iu mode MSC the user plane between the anchor MSC or MGW and the visited MSC or MGW shall comply to:

- the A-TRAU' protocol if both MSCs are connected via a TDM interface except for the transparent case FNUR = 32 kbit/s (ITC = UDI or RDI), FNUR = 56 kbit/s (ITC=RDI) and FNUR = 64 kbit/s (ITC=UDI). For these exceptions a plain 64 kbit/s channel is used between the MSCs. The rate adaptation between 64 kbit/s and 32 kbit/s is based on ITU-T Recommendation I.460 [2].
- the Nb UP protocol if the anchor MSC or MGW and the visited MSC or MGW are connected via an ATM interface or IP interface. The NbUP shall be configured in support mode, the data is transported in a 64 kbit/s bit stream, formatted in SDUs of 40 octets and transmitted every 5 ms, in accordance with Annex P of ITU-T Recommendation I.366.2 [81]. PDU type 0 is used, i.e., payload CRC is applied. This is needed for the framing to be handled the same for all transports but the Frame Quality Classification control shall be ignored (3GUP property Delivery Of Erroneous SDUs = yes) and therefore interim nodes shall only pass on the CRC. The data is encoded between MSC-B/MGW-B (non-Anchor) and MSC-A/MGW-A (Anchor) as for the TDM case (A-TRAU' protocol or plain 64kbits/s).

After a handover from an Iu mode MSC to a GERAN Iu mode MSC the user plane between the anchor MSC or MGW and the visited MSC or MGW shall comply to

- the A-TRAU' and A-TRAU'' protocol if both MSC are connected via a TDM interface except for the transparent cases FNUR = 32 kbit/s (ITC = UDI), FNUR = 56 kbit/s (ITC=RDI) and FNUR = 64 kbit/s (ITC=UDI). For these exceptions a plain 64 kbit/s channel is used between the MSCs. The rate adaptation between 64kbit/s and 32kbit/s is based on ITU-T Recommendation I.460.
- the Nb UP protocol if the anchor MSC or MGW and the visited MSC or MGW are connected via an ATM interface or IP interface. The NbUP shall be configured in support mode, the data is transported in a 64 kbit/s bit stream, formatted in SDUs of 40 octets and transmitted every 5 ms, in accordance with Annex P of ITU-T Recommendation I.366.2 [81]. PDU type 0 is used, i.e., payload CRC is applied. This is needed for the framing to be handled the same for all transports but the Frame Quality Classification control shall be ignored (3GUP property Delivery Of Erroneous SDUs = yes) and therefore interim nodes shall only pass on the CRC. The data is encoded between MSC-B/MGW-B (non-Anchor) and MSC-A/MGW-A (Anchor) as for the TDM case (A-TRAU' protocol or plain 64kbits/s). Furthermore, Clause ~~44.6~~[12.1.3](#) is applicable.

11.5 Handover for 56kbit/s

The FNUR = 56 kbit/s in transparent mode can be supported in A/Gb mode by two configurations:

1. without IWF with the following channel codings
 - 2*TCH/F32.0
 - 5*TCH/F9.6
2. with IWF with the following channel coding
 - 4*TCH/F14.4

The FNUR = 56 kbit/s in transparent mode is supported in Iu mode by a configuration without IWF only. Therefore handover for 56kbit/s in transparent mode between Iu mode MSC and A/Gb mode can be supported only for configurations without IWF.

Note: Handover between configurations with and without IWF are also not supported within A/Gb mode.

11.6 Void

12 Transport Protocols

12.1 Core Network

~~11.6~~ ~~Transport within the Core Network~~

The Nb UP protocol is used to transport user data in the Core Network, see 3GPP TS 29.415 [80]. Figure 16 below shows different cases to consider:

1. Transport on the access side of the IWF
2. Transport beyond the IWF, i.e., between the IWF and the fixed network

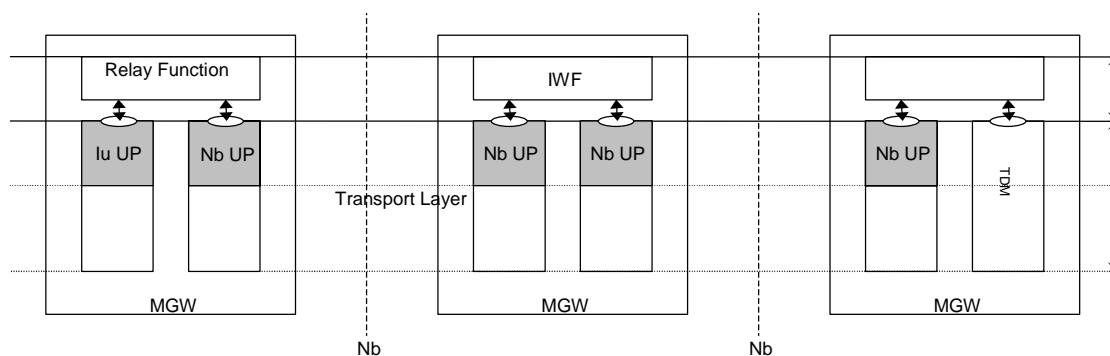

Figure 16: Transport of data within the Core Network

~~11.6~~ 12.1.1 Transport on the access side of the IWF

In case of an inter-MSC relocation, Clauses 11.4 and ~~11.6~~ 12.3 are applicable.

The following subclauses in this section are only applicable in other cases where the IWF is not interfacing an Iu UP layer protocol entity. For example, an MSC-server may control two MGWs and route the call through both, as one MGW interfaces Iu and the other one hosts the user plane part of the IWF.

~~11.6~~ 12.1.1.1 Non-transparent case

The Nb UP is used in support mode. The same SDU sizes and transmission intervals that are used on the Iu interface are used over the Nb interface, see 3GPP ~~TR-23.910 [53]~~ and 3GPP TS 27.001 [43]. A Relay Function (see 3GPP TS 29.232 [82]) is used to relay the user data and control information (such as rate control) in MGWs between the MGW where the IWF is residing and the Iu interface.

~~11.6~~ 12.1.1.2 Transparent case

The Nb UP is used in support mode.

11.6.12.1.2 Transport beyond the IWF

11.6.12.1.2.1 UDI and RDI

The data is transported in a 64 kbit/s bit stream, formatted in SDUs of 40 octets and transmitted every 5 ms, in accordance with Annex P of ITU-T Recommendation I.366.2 [81]. PDU type 0 is used, i.e., payload CRC is applied.

At the border between the CN and the fixed (ISDN) network, conversion between Nb UP and TDM shall be applied. In case of RDI interworking, the 56 kbit/s RDI bit stream is transmitted within the CN as 64 kbit/s bit stream where the last bit of each octet is ignored. For this reason the octet alignment shall be preserved in the SDUs transported in the CN.

11.6.12.1.2.2 Modem

The modem signals are PCM encoded and transported on a 64 kbit/s bit stream. The transmission is otherwise identical to the UDI/RDI case, see Section 11.6.2.1

11.6.12.1.3 Transport on the access side of the IWF after inter-MSC relocation

Clause 11.4 is applicable. Furthermore, the Nb UP is used in support mode; all interim Server nodes are assumed not to be aware of the relocation case – i.e. receive BICC IAM with same information as for connections beyond the IWF (clause 11.6.2). Figure 17 indicates the relevant connections, where MSC-A/MGW-A are the Anchor nodes and MSC-B/MGW-B are the Non-Anchor nodes.

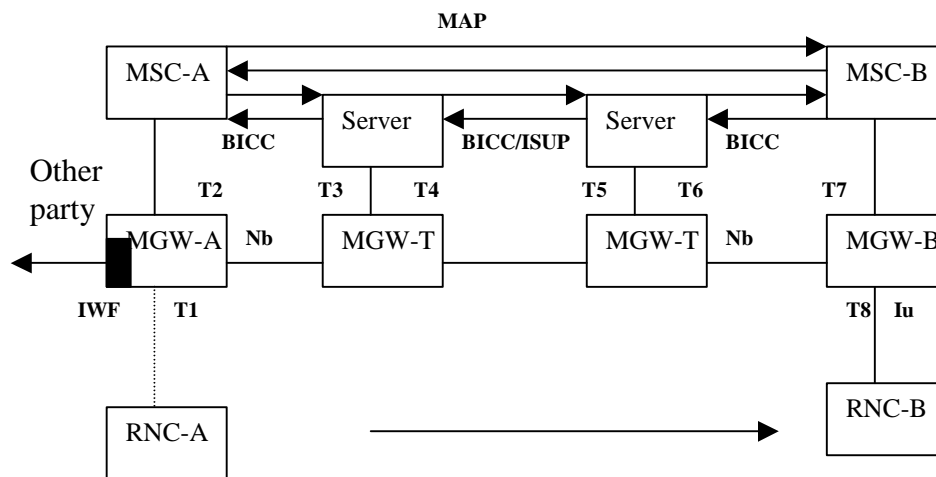

Figure 17: Bearer Independent connections for Inter-MSC SRNS Relocation

The Iu UP shall be initialised on each Nb leg in a forward direction (regardless if Forward Bearer or Backward Bearer procedures are used), i.e. in the direction of the IAM. For further details see TS 23.205 [83]

14.6.2.1.3.1 Non-Transparent CSD

Table 14: Non-Transparent CSD MGW Termination Properties For Inter-MSC SRNS Relocation

Termination Packages/Parameters	MSC-A		MSC-B		Intermediate Nodes
	T1	T2	T7	T8	T3, T4, T5, T6
TMR	-		UDI	-	UDI
threegcsd:plmnc	PLMN_BC	PLMN_BC	-	-	-
threegcsd:interface	RAN	CN	CN	RAN	CN
threegcsd:initdir	IN	OUT	IN	OUT	IN
threegcsd:mode	support	support	support	support	support
threegcsd:bitrate	-	-	-	BITRATE	-

14.6.2.1.3.2 Transparent CSD

Table 15: Transparent CSD MGW Termination Properties For Inter-MSC SRNS Relocation

Termination Packages/Parameters	MSC-A		MSC-B		Intermediate Nodes
	T1	T2	T7	T8	T3, T4, T5, T6
TMR	-	UDI	UDI	-	UDI
threegcsd:plmnc	-	-	-	-	-
threegcsd:interface	RAN	CN	CN	RAN	CN
threegcsd:mode	transparent	support	support	transparent	support
threegcsd:initdir	-	OUT	IN	-	IN
threegcsd:bitrate	-	-	-	BITRATE (note1 1)	-

Note 1: This is optional for the case when rate is 64kb/s then no rate adaptation is required.

12.2 NT services

On the Iu interface and if TDM is not used on the Nb interfaces between the access network and the IWF, this paragraph is applicable, except for the Nb interface in the case of inter-MSC relocation. The Iu and Nb user planes are used in support mode, see 3GPP TS 25.415 [42] and 3GPP TS 29.415 [80]. Each SDU corresponds to one RLP frame and, consequently, is 576 bits long. In GERAN Iu mode another SDU size of 480 bits is possible. It carries two RLP frames of 240 bits and is used if TCH/F9.6 is used in GERAN. Each SDU is transported in one Iu or Nb UP PDU of Type 1. In UTRAN Iu mode, the range of RAB Subflow Combination bit rate values is 14.4 kbit/s, 28.8 kbit/s, 57.6 kbit/s, limited by the maximum bit rate, and varies with the transmission period on the Uu interface, which is 40 ms, 20 ms or 10 ms. In GERAN Iu mode these values are valid if TCH/F14.4, TCH/28.8 or TCH/F43.2 is used. In addition GERAN Iu mode has a RAB Subflow Combination bit rate of 43.2 kbit/s with a transmission period of 13½ ms. If TCH/F9.6 is used, the range of RAB Subflow Combination bit rate values is 12 kbit/s, 24 kbit/s, 36 kbit/s, 48 kbit/s, limited by the maximum bit rate, and varies with the transmission period on the Um interface, which is 40 ms, 20 ms, 13½ ms or 10 ms. A change in the transmission period is signalled to the IWF through the Iu and Nb UP protocols. The Iu or Nb UP primitive Iu- or Nb-UP-DATA-REQUEST is invoked each time an RLP frame is ready to be sent from the IWF towards the UE. DTX indication is not used.

The following table shows the connection between the RAB subflow combination bit rate and the AIUR.

<u>RAB subflow combination bit rate</u>	<u>AIUR</u>	<u>Used number of traffic channels and channel coding for GERAN Iu mode</u>	<u>Comment</u>
57,6 kbit/s	57,6 kbit/s	4xTCH/F14.4, 2xTCH/F28.8	(Note 1)
43,2 kbit/s	43,2 kbit/s	3xTCH/F14.4, 1xTCH/F43.2	(Note 2)
48 kbit/s	38,4 kbit/s	4xTCH/F9.6	(Note 2)
36 kbit/s	28,8 kbit/s	3xTCH/F9.6	(Note 2)
28,8 kbit/s	28,8 kbit/s	2xTCH/F14.4, 1xTCH/F28.8	(Note 1)
24 kbit/s	19,2 kbit/s	2xTCH/F9.6	(Note 2)
14,4 kbit/s	14,4 kbit/s	1xTCH/F14.4	(Note 1)
12 kbit/s	9,6 kbit/s	1xTCH/F9.6	(Note 2)
NOTE 1: RAB subflow combination bit rate is used in UTRAN Iu mode and GERAN Iu mode			
NOTE 2: RAB subflow combination bit rate is only used in GERAN Iu mode			

For Inter-MSC relocation this paragraph is applicable for the Nb interface between the access network and the IWF. The Nb UP protocol is applied in support mode and the SDU size is 320 bits, transmitted every 5 ms. PDU type 0 is used. The data within the PDU is encoded as A-TRAU' frames.

If TDM is not used, then between the IWF and the fixed network (ISDN or PSTN), the Nb UP protocol is applied in support mode and the SDU size is 320 bits, transmitted every 5 ms. PDU type 0 is used.

12.3 T services

On the Iu interface, the Iu UP is used in transparent mode, see 3GPP TS 25.415 [42]. The payload of the Iu and Nb frames will consist of user data bits only for synchronous data, and RA0 synchronous bit streams for asynchronous data.

On the Iu interfaces, the payload (SDU) size is fixed, determined by the bit rate. Following table shows SDU sizes. AAL2 is used. The AAL2 SSCS layer shall be supported for segmentation and re-assembly.

<u>Bit rate</u>	<u>SDU size (= RLC PDU payload size)</u>
28.8 kbit/s	576 bits
33.6 kbit/s	672 bits
32 kbit/s	640 bits
56/64 kbit/s	640 bits

The primitive Iu-UP UNIT-DATA-REQUEST is invoked at regular intervals in order to have a constant bit rate (every SDU).

If TDM is not used at the Nb interface, then the Nb UP protocol is applied in support mode and the SDU size is 320 bits, transmitted every 5 ms. PDU type 0 is used.

12.3.1 Avoidance of delay at RNC

The TTI-to-CPS Packet packaging delay can be avoided by choosing the length of the CPS packet payload so that the payloads of an integer number of CPS Packets fill one TTI. The contents of the whole TTI can be sent further towards the MSC immediately after the reception without waiting for the next TTI.

12.3.2 Recovery from the loss of ATM cells

The ATM cell loss rate is estimated to be very small (less than 10^{-6} ... 10^{-8}), the quality of transmission being comparable to that of a high quality ISDN.

The following happens if a cell is lost (see ITU-T Recommendation I.363.2 [87]):

- At least one CPS packet is distorted.
- The distorted CPS packet(s) is/are discarded by the receiver.
- If only one CPS packet is discarded, the upper layer can identify the event by the UUI/SSSAR sequence number, and consequently insert a fill sequence of the length of a CPS payload field to the correct place in the bit stream. ITU-T Recommendation I.366.1 [88] (SSSAR) describes that UUI takes value between 0 and 26 for final data and value 27 for more data, but UUI should take value 26 for final data considering compatibility with other

SSCS specifications. When UUI works as sequence number by repetition of 27 and 26, CPS packet payload size is equal to half a SDU size. This CPS packet payload size also satisfies the requirement described in subclause 6.2.1. CPS packet payload size is set by ITU-T Recommendation Q.2630.1 [89] over Iu interface.

- If more than one CPS packets are discarded, the upper layer can identify the event by monitoring the buffer level at the ATM/TDM interface or by monitoring the reception of CPS packets with a timer. (The modulo 2 sequence number cannot indicate the loss of two consecutive CPS packets). The following figures apply for the 40 octet payload field.
- Worst case: 2 packets lost $\Rightarrow 2 \times 40 \text{ octets} \times 8 \text{ bits/octet} : 64 \text{ kbit/s} = 10 \text{ ms}$, i.e. buffer level decreased by 80 octets.
- Consequently, recovery with fill inserted in the correct place is possible, if the ATM cell jitter (i.e. transmission delay variation) is less than 5 ms. With a bigger jitter fill may be inserted in a wrong place in the TDM bit stream.