

Source: TSG CN WG 1

Title: CRs to R99 (with mirror CRs) on Work Item TEI towards 23.122, pack 2

Agenda item: 7.22

Document for: APPROVAL

Introduction:

This document contains 6 CRs on R99 (with mirror CRs) on Work Item "TEI", that have been agreed by TSG CN WG1, and are forwarded to TSG CN Plenary meeting #12 for approval.

Spec	CR	Rev	Doc-2nd-Level	Phase	Subject	Cat	Version-Current	Workitem
23.122	026	1	N1-010675	R99	Corrections and clarifications to PLMN Selection	F	3.6.0	TEI
23.122	027	1	N1-010676	Rel-4	Corrections and calrifications to PLMN selection	A	4.0.0	TEI
23.122	031		N1-010819	R99	Removal of 'Requirement of priority on High Quality Signal cell concerning Acceptable cell (for limited service as emergency call)' from 23.122	F	3.6.0	TEI
23.122	032		N1-010820	Rel-4	Removal of 'Requirement of priority on High Quality Signal cell concerning Acceptable cell (for limited service as emergency call)' from 23.122	A	4.0.0	TEI
23.122	033		N1-010821	R99	Alignment with stage 1 specification on PLMN background search	F	3.6.0	TEI
23.122	034		N1-010822	Rel-4	Alignment with stage 1 specification on PLMN background search	A	4.0.0	TEI

CHANGE REQUEST

CR-Form-v3

⌘ **23.122 CR 026** ⌘ rev **1** ⌘ Current version: **3.6.0** ⌘

For **HELP** on using this form, see bottom of this page or look at the pop-up text over the ⌘ symbols.

Proposed change affects: ⌘ (U)SIM ME/UE Radio Access Network Core Network

Title: ⌘ Corrections and clarifications to PLMN Selection

Source: ⌘ Ericsson

Work item code: ⌘ GSM/UMTS Interworking

Date: ⌘ 2001-05-09

Category: ⌘ **F**

Release: ⌘ R99

Use one of the following categories:

F (essential correction)

A (corresponds to a correction in an earlier release)

B (Addition of feature),

C (Functional modification of feature)

D (Editorial modification)

Detailed explanations of the above categories can be found in 3GPP TR 21.900.

Use one of the following releases:

2 (GSM Phase 2)

R96 (Release 1996)

R97 (Release 1997)

R98 (Release 1998)

R99 (Release 1999)

REL-4 (Release 4)

REL-5 (Release 5)

Reason for change: ⌘ For the definition of Available PLMN's in chapter 1.2 in 23.122 certain conditions defined in 3GPP TS 03.22 are stated. We should avoid defining conditions in two different specifications and instead make a reference to 3GPP TS 03.22, as has been done for 3GPP TS 25.304.

The headlines in chapters 4.3.2 and 4.3.3, makes a reference to figure 4, but the reference should be corrected to figure 3 (as figure 4 does not exist in this specification).

Furthermore we have different forbidden lists today handling forbidden LAs and PLMNs. It is not always clearly stated what forbidden list the text in 23.122 refers to, especially not for lists of forbidden LAs. In addition, if an additional forbidden list is added in the future to this specification, 23.122 can get even more confusing.

The statement in chapter 3.2 "If the MS cannot find a suitable cell, the MS performs the PLMN selection procedure starting at subclause 4.4.3.1 A or B" should be deleted, as a cell in which the MS receives "LA not allowed" is still a suitable cell. The MS is not allowed any service in this cell and the MS will continue the cell re-selection in order to find a better cell, but the MS shall not trigger the PLMN selection until it has lost coverage. This CR proposes to delete this sentence as it is confusing. In addition we proposes to add the following sentence: "The MS shall camp on the cell for limited service." This aligns 23.122 with 22.011.

This CR also proposes to delete the sentence in chapter 4.4.5: "This requirement applies to all MSs" as the sentence is confusing. All requirements in this

specification applies to all mobiles, unless it is explicitly stated.

Summary of change:	⌘ References to sub-chapters in 03.22 are deleted. Two references to figure 4 in chapters 4.3.2 and 4.3.3 are corrected to figure 3. It has been clarified which forbidden list 23.122 refers to whenever the handling of the forbidden lists are described, to align with other specifications as 24.008. The following sentence in chapter 3.2 has been deleted: "If the MS cannot find a suitable cell, the MS performs the PLMN selection procedure starting at subclause 4.4.3.1 A or B". The following statement in chapter 4.4.5 has been deleted: "This requirement applies to all MSs".
Consequences if not approved:	⌘ The description of the LR reject cause values (and the behaviour of the registering MS) is unclear and not consistent with 22.011 and 24.008. Also the description (naming) of the forbidden lists is confusing.

Clauses affected: ⌘ 1.2, 3.1, 3.2, 4.3.2, 4.3.3, 4.4.5

Other specs Affected: ⌘ Other core specifications ⌘
 Test specifications
 O&M Specifications

Other comments: ⌘

1.2 Definitions and abbreviations

For the purposes of the present document the abbreviations given in 3GPP TS 01.04 and 3GPP TS 21.905 apply.

(A/Gb mode only): Indicates this clause or subclause applies only to GSM system. For multi system case this is determined by the current serving radio access network.

(Iu mode only): Indicates this clause or subclause applies only to UMTS system. For multi system case this is determined by the current serving radio access network.

Acceptable Cell: This is a cell that the MS may camp on to make emergency calls. It must satisfy criteria which is defined for A/Gb mode in 3GPP TS 03.22 and for Iu mode in 3GPP TS 25.304.

Access Technology: The access technology associated with a PLMN. The MS uses this information to determine what type of radio carrier to search for when attempting to select a specific PLMN (e.g., GSM, UMTS or GSM COMPACT). A PLMN may support more than one access technology.

Allowable PLMN: In the case of a MS operating in MS operation mode A or B, this is a PLMN which is not in the list of “forbidden PLMNs” in the MS.

In the case of a MS operating in MS operation mode C, this is a PLMN which is not in the list of “forbidden PLMNs” or in the list of “forbidden PLMNs for GPRS service” in the MS

Available PLMN: This is a PLMN where the MS has found a cell that satisfies conditions (ii) and (iv) of subclause 3.2.1 in 3GPP TS 03.22. For Iu mode the criteria is specified in 3GPP TS 25.304. For A/Gb mode this is a PLMN where the MS has found a cell that satisfies certain conditions specified in 3GPP TS 03.22. For Iu mode this is a PLMN where the MS has found a cell that satisfies certain conditions specified in 3GPP TS 25.304.

Camped on a cell: The MS (ME if there is no SIM) has completed the cell selection/reselection process and has chosen a cell from which it plans to receive all available services. Note that the services may be limited, and that the PLMN may not be aware of the existence of the MS (ME) within the chosen cell.

Current serving cell: This is the cell on which the MS is camped.

CTS MS: An MS capable of CTS services is a CTS MS.

GPRS MS: An MS capable of GPRS services is a GPRS MS.

MS operation mode See GSM 03.60[27].

High quality signal: The high quality signal limit is used in the PLMN selection procedure. It is defined in the appropriate AS specification: GSM TS 03.22 for the GSM radio access technology, 3G TS 25.304 for the UMTS radio access technology (FDD or TDD mode).

Home PLMN: This is a PLMN where the MCC and MNC of the PLMN identity match the MCC and MNC of the IMSI. Matching criteria are defined in Annex A.

In A/Gb mode,...: Indicates this paragraph applies only to GSM System. For multi system case this is determined by the current serving radio access network.

In Iu mode,...: Indicates this paragraph applies only to UMTS System. For multi system case this is determined by the current serving radio access network.

Localised Service Area (LSA): A localised service area consists of a cell or a number of cells. The cells constituting a LSA may not necessarily provide contiguous coverage.

Location Registration (LR): An MS which is IMSI attached to non-GPRS services only performs location registration by the Location Updating procedure. A GPRS MS which is IMSI attached to GPRS services or to GPRS and non-GPRS services performs location registration by the Routing Area Update procedure only when in a network of network operation mode I. Both procedures are performed independently by the GPRS MS when it is IMSI attached to GPRS and non-GPRS services in a network of network operation mode II or III (see 3GPP TS 23.060).

MS: Mobile Station. This specification makes no distinction between MS and UE.

Network Type: The network type associated with HPLMN or a PLMN on the PLMN selector (see GSM 11.11). The MS uses this information to determine what type of radio carrier to search for when attempting to select a specific PLMN. A PLMN may support more than one network type.

Registered PLMN (RPLMN): This is the PLMN on which certain LR outcomes have occurred (see table 1).

Registration: This is the process of camping on a cell of the PLMN and doing any necessary LRs.

Registration Area: A registration area is an area in which mobile stations may roam without a need to perform location registration. The registration area corresponds to location area (LA) for performing location updating procedure and it corresponds to routing area for performing the routing area update procedure.

The PLMN to which a cell belongs (PLMN identity) is given in the system information transmitted on the BCCH (MCC + MNC part of LAI).

Selected PLMN: This is the PLMN that has been selected according to subclause 3.1, either manually or automatically.

SIM: Subscriber Identity Module (see 3GPP TS 02.17). This specification makes no distinction between SIM and USIM.

SoLSA exclusive access: Cells on which normal camping is allowed only for MS with Localised Service Area (LSA) subscription.

Suitable Cell: This is a cell on which an MS may camp. It must satisfy criteria which is defined for A/Gb mode in 3GPP TS 03.22 and for Iu mode in 3GPP TS 25.304.

Visited PLMN of home country: This is a PLMN, different from the home PLMN, where the MCC part of the PLMN identity is the same as the MCC of the IMSI.

Visited PLMN: This is a PLMN, different from the home PLMN.

2 General description of idle mode

When an MS is switched on, it attempts to make contact with a public land mobile network (PLMN). The particular PLMN to be contacted may be selected either automatically or manually.

The MS looks for a suitable cell of the chosen PLMN and chooses that cell to provide available services, and tunes to its control channel. This choosing is known as "camping on the cell". The MS will then register its presence in the registration area of the chosen cell if necessary, by means of a location registration (LR), GPRS attach or IMSI attach procedure.

If the MS loses coverage of a cell, or find a more suitable cell, it reselects onto the most suitable cell of the selected PLMN and camps on that cell. If the new cell is in a different registration area, an LR request is performed.

If the MS loses coverage of a PLMN, either a new PLMN is selected automatically, or an indication of which PLMNs are available is given to the user, so that a manual selection can be made.

Registration is not performed by MSs only capable of services that need no registration.

The purpose of camping on a cell in idle mode is fourfold:

- a) It enables the MS to receive system information from the PLMN.
- b) If the MS wishes to initiate a call, it can do this by initially accessing the network on the control channel of the cell on which it is camped (with the exceptions defined in 3GPP TS 03.22 subclauses 3.5.3 and 3.5.4 and 3GPP TS 25.304).
- c) If the PLMN receives a call for the MS, it knows (in most cases) the registration area of the cell in which the MS is camped. It can then send a "paging" message for the MS on control channels of all the cells in the registration area. The MS will then receive the paging message because it is tuned to the control channel of a cell in that registration area, and the MS can respond on that control channel.
- d) It enables the MS to receive cell broadcast messages.

If the MS is unable to find a suitable cell to camp on, or the SIM is not inserted, or if it receives certain responses to an LR request (e.g., "illegal MS"), it attempts to camp on a cell irrespective of the PLMN identity, and enters a "limited service" state in which it can only attempt to make emergency calls.

In A/Gb mode, if the CTS MS is in CTS mode only or in automatic mode with CTS preferred, it will start by attempting to find a CTS fixed part on which it is enrolled

The idle mode tasks can be subdivided into 4 processes:

- PLMN selection;
- Cell selection and reselection;
- Location registration;
- CTS fixed part selection (A/Gb mode only).

In A/Gb mode, to make this initial CTS fixed part selection, the MS shall be enrolled on at least one fixed part.

The relationship between these processes is illustrated in figure 1 in clause 5. The states and state transitions within each process are shown in figures 2 to 4 in clause 5.

3 Requirements and technical solutions

The following subclauses list the main requirements of idle mode operation and give an outline of the technical solution.

3.1 PLMN selection and roaming

The MS normally operates on its home PLMN (HPLMN). However a visited PLMN (VPLMN) may be selected, e.g., if the MS loses coverage. There are two modes for PLMN selection:

- i) Automatic mode - This mode utilizes a list of PLMNs in priority order. The highest priority PLMN which is available and allowable is selected.
- ii) Manual mode - Here the MS indicates to the user which PLMNs are available. Only when the user makes a manual selection does the MS try to obtain normal service on the VPLMN.

There are two cases:

- International Roaming - This is where the MS receives service on a PLMN of a different country than that of the HPLMN.
- National Roaming - This is where the MS receives service from a PLMN of the same country as that of the HPLMN, either anywhere or on a regional basis. The MS makes a periodic search for the HPLMN while national roaming.

To prevent repeated attempts to have roaming service on a not allowed LA, when the MS is informed that an LA is forbidden, the LA is added to a list of "forbidden LAs for roaming" which is stored in the MS. This list is deleted when the MS is switched off or when the SIM is removed. Such area restrictions are always valid for complete location areas independent of possible subdivision into GPRS routing areas. The structure of the routing area identifier (3GPP TS 23.003) supports area restriction on LA basis.

If a "PLMN not allowed" message is received by an MS in response to an LR request from a VPLMN, that VPLMN is added to a list of "forbidden PLMNs" in the SIM and thereafter that VPLMN will not be accessed by the MS when in automatic mode. A PLMN is removed from the "forbidden PLMNs" list if, after a subsequent manual selection of that PLMN, there is a successful LR. This list is retained when the MS is switched off or the SIM is removed. The HPLMN shall not be stored on the list of "forbidden PLMNs".

In A/Gb mode, an ME not supporting SoLSA may consider a cell with the escape PLMN code (see 3GPP TS 23.073) to be a part of a PLMN belonging to the list of "forbidden PLMNs".

Optionally the ME may store in its memory an extension of the "forbidden PLMNs" list. The contents of the extension of the list shall be deleted when the MS is switched off or the SIM is removed.

If a "GPRS services not allowed in this PLMN" message is received by an MS in response to an GPRS attach, GPRS detach or routing area update request from a VPLMN, that VPLMN is added to a list of "forbidden PLMNs for GPRS service" which is stored in the MS and thereafter that VPLMN will not be accessed by the MS for GPRS service when in automatic mode. This list is deleted when the MS is switched off or when the SIM is removed. A PLMN is removed from the list of "forbidden PLMNs for GPRS service" if, after a subsequent manual selection of that PLMN, there is a successful GPRS attach. The maximum number of possible entries in this list is implementation dependant, but must be at least one entry. The HPLMN shall not be stored on the list of "forbidden PLMNs for GPRS service".

3.2 Regional provision of service

An MS may have a "regionally restricted service" where it can only obtain service on certain LAs. If such an MS attempts to camp on a cell of an LA for which it does not have service entitlement, when it does an LR request, it will receive an "LA not allowed" message. In this case:

- The MS stores the forbidden LA identity (LAI) in a list of "forbidden LAIs for regional provision of service", to prevent repeated access attempts on a cell of the forbidden LA. This list is deleted when the MS is switched off or the SIM is removed. ~~If the MS cannot find a suitable cell, the MS performs the PLMN selection procedure starting at subclause 4.4.3.1 A or B. The MS enters the limited service state.~~

In A/Gb mode, a cell may be reserved for SoLSA exclusive access (see 3GPP TS 24.008 and 04.60). An MS is only allowed to camp normally on such a cell if it has a Localised Service Area subscription to the cell. Other MS may ~~camp~~ enter ~~for~~ the limited service state.

- NOTE: In A/Gb mode, in a SoLSA exclusive cell the MCC+MNC code is replaced by an unique escape PLMN code (see 3GPP TS 23.073), not assigned to any PLMN, in SI3 and SI4. An MS not supporting SoLSA may request for location update to an exclusive access cell. In this case the location attempt is rejected with the cause "PLMN not allowed" and the escape PLMN code is added to the list of the "forbidden PLMNs".

3.3 Borders between registration areas

If the MS is moving in a border area between registration areas, it might repeatedly change between cells of different registration areas. Each change of registration area would require an LR, which would cause a heavy signalling load and increase the risk of a paging message being lost. The access stratum shall provide a mechanism to limit this effect.

3.4 Access control

3.4.1 Access control

Due to problems in certain areas, Network Operators may decide to restrict access from some MSs (e.g., in case of congestion), and for this reason an access control mechanism shall be provided.

3.4.2 Forbidden LA for regional provision of service

When the MS is camped on a cell, the LA of which belongs to the list of “forbidden LAs for regional provision of service”, the MS is not allowed to initiate establishment of a CM connection except for an emergency call; it may respond to paging. Also, the MS is not allowed to request GPRS services when camped on a cell of a LA of which belongs to the list of “forbidden LAs for regional provision of service”.

3.5 No suitable cell (limited service state)

There are a number of situations in which the MS is unable to obtain normal service from a PLMN. These include:

- a) Failure to find a suitable cell of the selected PLMN;
- b) No SIM in the MS;
- c) A "PLMN not allowed" response to an LR;
- d) An "illegal MS", "illegal ME" or "IMSI unknown in HLR" response to an LR; (Any SIM in the ME is then considered "invalid".)
- e) A "GPRS not allowed" response to an LR of a GPRS MS attached to GPRS services only. (The cell selection state of GPRS MSs attached to GPRS and non-GPRS depends on the outcome of the location updating.)

(In automatic PLMN selection mode, events (a), (c) and (e) would normally cause a new PLMN selection, but even here, the situation may arise when no PLMNs are available and allowable for use).

Under any of these conditions, the MS attempts to camp on an acceptable cell, irrespective of its PLMN identity and giving priority to cell with received high quality signal, so that emergency calls can be made if necessary. When in the limited service state with a valid SIM, the MS shall search for available and allowable PLMNs in the manner described in subclause 4.4.3.1 and when indicated in the SIM also as described in subclause 4.4.3.4. No LR requests are made until a valid SIM is present and either a suitable cell is found or a manual network reselection is performed. In the limited service state the presence of the MS need not be known to the PLMN on whose cell it has camped.

NOTE: High quality signal is defined in the appropriate AS specification.

There are also other conditions under which only emergency calls may be made. These are shown in table 2 in clause 5.

3.6 CTS fixed part selection (A/Gb mode only)

In CTS mode only or in automatic mode with CTS preferred, the CTS MS normally operates on a CTS fixed part on which the mobile station is already enrolled. If the CTS MS loses CTS coverage in these modes, it shall attempt periodically to select again a CTS fixed part.

To select a CTS fixed part, the CTS MS shall listen to the CTSBCH frequencies of all the fixed parts on which the MS is currently enrolled.

If the CTS MS is moving in a border area between one area with CTS coverage and one without it, it might repeatedly require CTS attachments and LU on the PLMN. To prevent this, the criteria C1_CTS and C2_CTS (defined in 3GPP TS 05.08 subclause 11.1) are used. To attach to a CTS FP, the C1_CTS criterion shall be greater than zero. When the C2_CTS criterion falls below zero, the CTS MS shall consider itself to be no more under CTS coverage.

4 Overall process structure

4.1 Process goal

The aim of the idle mode processes is to ensure that the registered PLMN is the selected PLMN.

4.2 States description

Each of the processes of PLMN selection, cell selection and location registration can be described by a set of states. The overall state of the mobile is thus a composite of the states of the three processes. In some cases, an event which causes a change of state in one process may trigger a change of state in another process, e.g., camping on a cell in a new registration area triggers an LR request. The relationship between the processes is illustrated in figure 1 in clause 5.

The states in which the MS may be, for each of the processes, are described below and illustrated in figures 2 to 4 in clause 5. For many of the states, a fuller description can be found in other Technical Specifications, and a reference to the Technical Specification is given after the state description. In the event of any conflict between the diagrams and the text in the present document, the text takes precedence.

4.3 List of states

4.3.1 List of states for the PLMN selection process

4.3.1.1 List of states for automatic mode (figure 2a)

- | | |
|----|---|
| A1 | Trying RPLMN - The MS is trying to perform a Location Registration on the registered PLMN. |
| A2 | On PLMN - The MS has successfully registered on a PLMN. |
| A3 | Trying PLMN - The MS is trying to register on a PLMN in the ordered list of PLMNs. |
| A4 | Wait for PLMNs to appear - There are no allowable and available PLMNs at present and the MS is waiting for one to appear. |
| A5 | HPLMN search in progress - The MS is trying to find if the HPLMN is available. |
| A6 | No SIM - There is no SIM in the MS, or certain LR responses have been received. |

4.3.1.2 List of states for manual mode (figure 2b)

- | | |
|----|--|
| M1 | Trying registered PLMN - The MS is trying to perform a Location Registration on the registered PLMN. |
| M2 | On PLMN - The MS has successfully registered on a PLMN. |
| M3 | Not on PLMN - The MS has failed to register on the selected PLMN. |
| M4 | Trying PLMN - The MS is trying to register on a user selected PLMN. |
| M5 | No SIM - There is no SIM in the MS, or certain LR responses have been received. |

4.3.2 List of states for location updating (figure 3_4)

The states are entered depending on responses to location update (LU) requests.

4.3.3 List of states for location registration (figure 3_4)

The states are entered depending on responses to location registration (LR) requests. Independent update states exist for GPRS and for non-GPRS operation in MSs capable of GPRS and non-GPRS services.

- | | |
|----|---|
| L1 | Updated - The MS enters this state if an LR request is accepted. The update status is set to "updated". The GPRS and the non-GPRS update state of a MS may enter "updated" as a result of combined signalling or as a result of individual signalling depending on the capabilities of the network. |
|----|---|

- | | |
|----|---|
| L2 | Idle, No IMSI - The MS enters this state if an LR request is rejected with cause: |
|----|---|

- a) IMSI unknown in HLR;
- b) illegal ME;
- c) illegal MS;
- d) GPRS services and non-GPRS services not allowed;

or if there is no SIM. All update states of a MS enter this state regardless whether received by individual or combined signalling for events b) and c). Event a) has no influence on the GPRS update state. Events b), c) and d) results in "Roaming not allowed" for the GPRS update state.

If a SIM is present, the non-GPRS update status of the SIM is set to "Roaming not allowed".

- | | |
|----|--|
| L3 | Roaming not allowed - The MS enters this state if it receives an LU reject message with the cause: |
|----|--|

- a) PLMN not allowed;
- b) Location area not allowed;
- c) Roaming not allowed in this location area.
- d) GPRS services not allowed in this PLMN

Except from event d) all update states of the MS are set to "Roaming not allowed" regardless whether received by individual or combined signalling. Event d) results in "Roaming not allowed" for the GPRS update state only. Event d) has no influence on the non-GPRS update state. The behaviour of the MS in the roaming not allowed state is dependent on the LR reject cause as shown in table 2 in clause 5. Additionally:

- in automatic mode, "PLMN not allowed" and "roaming not allowed in this location area" cause the Automatic Network Selection procedure of subclause 4.4.3.1.1 to be started; it is also caused by "GPRS services not allowed in this PLMN" when received by a GPRS MS operating in MS operation mode C;
- in manual mode, "PLMN not allowed" and "roaming not allowed" cause the Manual Network Selection procedure of subclause 4.4.3.1.2 to be started; it is also caused by "GPRS services not allowed in this PLMN" when received by a GPRS MS operating in MS operation mode C.

L4 Not updated - The MS enters this state if any LR failure not specified for states L2 or L3 occurs, in which cases the MS is not certain whether or not the network has received and accepted the LR attempt. The non-GPRS update status on the SIM and/or the GPRS update status are set to "not updated" depending on the specific location registration procedure and their outcome.

NOTE This clause does not describe all the cases. For more details refer to 3GPP TS 24.008 [23]

4.4 PLMN selection process

4.4.1 Introduction

There are two modes for PLMN selection, automatic and manual. These are described in subclauses 4.4.3 below and illustrated in figures 2a to 2b in clause 5.

4.4.2 Registration on a PLMN

The MS shall perform registration on the PLMN if the MS is capable of services which require registration. In both automatic and manual modes, the concept of registration on a PLMN is used. An MS successfully registers on a PLMN if:

- a) The MS has found a suitable cell of the PLMN to camp on; and
- b) An LR request from the MS has been accepted in the registration area of the cell on which the MS is camped (see table 1).

4.4.3 PLMN selection

The registration on the selected PLMN and the location registration are only necessary if the MS is capable of services which require registration. Otherwise, the PLMN selection procedures are performed without registration.

The "HPLMN Selector with Access Technology", "User Controlled PLMN Selector with Access Technology" and "Operator Controlled PLMN Selector with Access Technology" data fields in the SIM include associated access technologies for each PLMN entry, see GSM 11.11 [32]. The PLMN/access technology combinations are listed in priority order. If an entry includes more than one access technology, then no priority is defined for the preferred access technology and the priority is an implementation issue. The Mobile Equipment stores a list of "equivalent PLMNs". This list is replaced or deleted at the end of each location update procedure, routing area update procedure and GPRS attach procedure. The stored list consists of a list of equivalent PLMNs as downloaded by the network plus the PLMN code of the network

that downloaded the list. All PLMNs in the stored list are regarded as equivalent to each other for PLMN selection, cell selection/re-selection and handover.

The MS shall not use the PLMN codes contained in the "HPLMN Selector with Access Technology" data field.

NOTE: To allow provision for multiple HPLMN codes, the HPLMN access technologies are stored on the SIM together with PLMN codes. This version of the specification does not support multiple HPLMN codes and the "HPLMN Selector with Access Technology" data field is only used by the MS to get the HPLMN access technologies. The HPLMN code is the PLMN code included in the IMSI.

NOTE: Different GSM frequency bands (eg. 900, 1800, 1900, 400) are all considered GSM access technology. An MS supporting more than one band should scan all the bands it supports when scanning for GSM frequencies. However GSM COMPACT systems which use GSM frequency bands but with the CBPCCH broadcast channel are considered as a separate access technology from GSM.

4.4.3.1 At switch-on or recovery from lack of coverage

At switch on, or following recovery from lack of coverage, the MS selects the registered PLMN or equivalent PLMN (if it is available) using all access technologies that the MS is capable of and if necessary (in the case of recovery from lack of coverage, see subclause 4.5.2) attempts to perform a Location Registration.

EXCEPTION: In A/Gb mode or GSM COMPACT, an MS with voice capability, shall not search for CPBCCCH carriers, unless the "RPLMN Last Used Access Technology" field is available in the SIM and indicates GSM COMPACT. In A/Gb mode or GSM COMPACT, an MS not supporting packet services shall not search for CPBCCCH carriers.

If successful registration is achieved, the MS indicates the selected PLMN.

If there is no registered PLMN, or if registration is not possible due to the PLMN being unavailable or registration failure, the MS follows one of the following two procedures depending on its operating mode.

EXCEPTION: If registration is not possible on recovery from lack of coverage due to the registered PLMN being unavailable, a MS attached to GPRS services may, optionally, continue looking for the registered PLMN for an implementation dependent time.

NOTE 1: A MS attached to GPRS services should use the above exception only if one or more PDP contexts are currently active.

4.4.3.1.1 Automatic Network Selection Mode Procedure

The MS selects and attempts registration on other PLMNs, if available and allowable, in the following order:

- i) HPLMN (if not previously selected);
- ii) each PLMN in the "User Controlled PLMN Selector with Access Technology" data field in the SIM (in priority order);
- iii) each PLMN in the "Operator Controlled PLMN Selector with Access Technology" data field in the SIM (in priority order);
- iv) other PLMN/access technology combinations with received high quality signal in random order;
- v) other PLMN/access technology combinations in order of decreasing signal quality.

When following the above procedure the following requirements apply:

- a) In A/Gb mode or GSM COMPACT, an MS with voice capability shall ignore PLMNs for which the MS has identified at least one cell that do not offer voice service. (In A/Gb mode, this is indicated by the CELL_BAR_QUALIFY_2 parameter).

- b) In A/Gb mode or GSM COMPACT, an MS with voice capability , or an MS not supporting packet services shall not search for CPBCCCH carriers.
- c) In ii and iii, the MS should limit its search for the PLMN to the access technology or access technologies associated with the PLMN in the appropriate PLMN Selector with Access Technology list (User Controlled or Operator Controlled selector list). An MS using a SIM without access technology information storage (i.e. the “User Controlled PLMN Selector with Access Technology” and the “Operator Controlled PLMN Selector with Access Technology” data fields are not present) shall instead use the “PLMN Selector” data field, for each PLMN in the “PLMN Selector” data field, the MS shall search for all access technologies it is capable of and shall assume GSM access technology as the highest priority radio access technology.
- d) In iv and v, the MS shall search for all access technologies it is capable of, before deciding which PLMN to select.
- e) In ii, and iii, a packet only MS which supports GSM COMPACT, but using a SIM without access technology information storage (i.e. the “User Controlled PLMN Selector with Access Technology” and the “Operator Controlled PLMN Selector with Access Technology” data fields are not present) shall instead use the “PLMN Selector” data field, for each PLMN in the “PLMN Selector” data field, the MS shall search for all access technologies it is capable of and shall assume GSM COMPACT access technology as the lowest priority radio access technology.
- f) In i, the MS shall search for all access technologies it is capable of. The MS shall start its search using the access technologies stored in the “HPLMN Selector with Access Technology” data field on the SIM in priority order as defined in section 4.4.3 (i.e. the PLMN/access technology combinations are listed in priority order, if an entry includes more than one access technology then no priority is defined for the preferred access technology and the priority is an implementation issue).
- g) In i, an MS using a SIM without access technology information storage (i.e. the “HPLMN Selector with Access Technology” data field is not present) shall search for all access technologies it is capable of and shall assume GSM access technology as the highest priority radio access technology. A packet only MS which supports GSM COMPACT using a SIM without access technology information storage shall also assume GSM COMPACT access technology as the lowest priority radio access technology.
- h) In v, the MS shall order the PLMN/access technology combinations in order of decreasing signal quality within each access technology. The order between PLMN/access technology combinations with different access technologies is an MS implementation issue.

NOTE: Requirements a) and b) apply also to requirement d), so a GSM voice capable MS should not search for GSM COMPACT PLMNs, even if capable of GSM COMPACT.

NOTE: Requirements a) and b) apply also to requirement f), so a GSM voice capable MS should not search for GSM COMPACT PLMNs, even if this is the only access technology on the “HPLMN Selector with Access Technology” data field on the SIM. Also PLMNs not offering voice services should be ignored by voice capable GSM mobiles.

NOTE: High quality signal is defined in the appropriate AS specification.

If successful registration is achieved, the MS indicates the selected PLMN.

If registration cannot be achieved because no PLMNs are available and allowable, the MS indicates "no service" to the user, waits until a new PLMN is available and allowable and then repeats the procedure.

If there were one or more PLMNs which were available and allowable, but an LR failure made registration on those PLMNs unsuccessful or an entry in a the “forbidden LAIs for regional provision of service” list prevented a registration attempt, the MS selects the first such PLMN again and enters a limited service state.

4.4.3.1.2 Manual Network Selection Mode Procedure

The MS indicates whether there are any PLMNs, which are available using all supported access technologies. This includes PLMNs in the "Forbidden PLMNs" list and PLMNs which only offer services not supported by the MS. An MS which supports GSM COMPACT shall also indicate GSM COMPACT PLMNs (which use PBCCH).

If displayed, PLMNs meeting the criteria above are presented in the following order:

- i)- HPLMN;
- ii)- PLMNs contained in the " User Controlled PLMN Selector with Access Technology " data field in the SIM (in priority order);
- iii)- PLMNs contained in the "Operator Controlled PLMN Selector with Access Technology" data field in the SIM (in priority order);
- iv)- other PLMN/access technology combinations with received high quality signal in random order;
- v)- other PLMN/access technology combinations in order of decreasing signal quality.

In ii and iii, an MS using a SIM without access technology information storage (i.e. the "User Controlled PLMN Selector with Access Technology" and the "Operator Controlled PLMN Selector with Access Technology" data fields are not present) shall instead present the PLMNs contained in the "PLMN Selector" data field in the SIM (in priority order).

In v, requirement h) in section 4.4.3.1.1 applies.

In A/Gb mode or GSM COMPACT, if a PLMN does not support voice services then this shall be indicated to the user.

The user may select his desired PLMN and the MS then initiates registration on this PLMN using the access technology chosen by the user for that PLMN or using the highest priority available access technology for that PLMN, if the associated access technologies have a priority order. (This may take place at any time during the presentation of PLMNs). For such a registration, the MS shall ignore the contents of the "forbidden LAs for roaming", "forbidden LAs for regional provision of service", "forbidden PLMNs for GPRS service" lists and "forbidden PLMNs" lists.

NOTE: It is an MS implementation option whether to indicate access technologies to the user. If the MS does display access technologies, then the access technology used should be the access technology chosen by the user for that PLMN. If the MS does not display access technologies, then the access technology chosen for a particular PLMN should be the highest priority available access technology for that PLMN, if the associated access technologies have a priority order.

If the user does not select a PLMN, the selected PLMN shall be the one that was selected before the PLMN selection procedure started. If no such PLMN was selected or that PLMN is no longer available, then the MS shall attempt to camp on any acceptable giving priority to cell with received high quality signal cell and enter the limited service state.

NOTE: High quality signal is defined in the appropriate AS specification.

4.4.3.2 User reselection

At any time the user may request the MS to initiate reselection and registration onto an available PLMN, according to the following procedures, dependent upon the operating mode.

4.4.3.2.1 Automatic Network Selection Mode

The MS selects and attempts registration on PLMNs, if available and allowable, in all of its bands of operation in accordance with the following order:

- i) HPLMN;
- ii) PLMNs contained in the " User Controlled PLMN Selector with Access Technology" data field in the SIM (in priority order) excluding the previously selected PLMN;

- iii) PLMNs contained in the "Operator Controlled PLMN Selector with Access Technology" data field in the SIM (in priority order) excluding the previously selected PLMN;
- iv) other PLMN/access technology combinations with the received high quality signal in random order excluding the previously selected PLMN;
- v) other PLMN/access technology combinations, excluding the previously selected PLMN in order of decreasing signal quality or, alternatively, the previously selected PLMN may be chosen ignoring its signal quality;
- vi) The previously selected PLMN.

The previously selected PLMN is the PLMN which the MS has selected prior to the start of the user reselection procedure.

NOTE: If the previously selected PLMN is chosen, and registration has not been attempted on any other PLMNs, then the MS is already registered on the PLMN, and so registration is not necessary.

When following the above procedure the requirements a), b), c), e), f), g), h) in section 4.4.3.1.1 apply: Requirement d) shall apply as shown below:

- d) In iv, v, and vi, the MS shall search for all access technologies it is capable of before deciding which PLMN to select.

NOTE: High quality signal is defined in the appropriate AS specification.

4.4.3.2.2 Manual Network Selection Mode

The Manual Network Selection Mode Procedure of subclause 4.4.3.1.2 is followed.

4.4.3.3 In VPLMN

If the MS is in a VPLMN and the HPLMN is not in the stored list of equivalent PLMNs, the MS shall periodically attempt to obtain service on its HPLMN or higher priority PLMN listed in "user controlled PLMN selector" or "operator controlled PLMN selector" by scanning in accordance with the requirements that are applicable to i), ii) and iii) as defined in the Automatic Network Selection Mode in clause 4.4.3.1.1. In the case that the mobile has a stored "Equivalent PLMNs" list the mobile shall only select a PLMN if it is of a higher priority than any of those stored in the "Equivalent PLMNs" list. For this purpose, a value T minutes may be stored in the SIM, T is either in the range 6 minutes to 8 hours in 6 minute steps or it indicates that no periodic attempts shall be made. If no value is stored in the SIM, a default value of 60 minutes is used.

The attempts to access the HPLMN or higher priority PLMN shall be as specified below:

- a) The periodic attempts shall only be performed in automatic mode when the MS is roaming;
- b) After switch on, a period of at least 2 minutes and at most T minutes shall elapse before the first attempt is made;
- c) The MS shall make an attempt if the MS is on the VPLMN at time T after the last attempt;
- d) Periodic attempts shall only be performed by the MS while in idle mode;
- e) If the HPLMN or higher priority PLMN is not found, the MS shall remain on the VPLMN.
- f) In steps i), ii) and iii) the MS shall limit its attempts to access higher priority PLMNs to PLMNs of the same country as the current serving VPLMN.

4.4.3.4 Investigation Scan for higher prioritized PLMN

The support of this procedure is mandatory if the ME supports GSM COMPACT and otherwise optional. A MS capable of both GSM voice and packet service shall, when indicated in the SIM, investigate if there is service from a higher prioritized PLMN not offering GSM voice service, either HPLMN or a PLMN in a "PLMN Selector with Access Technology " data field on the SIM.

The MS shall scan for PLMNs in accordance with the requirements described for automatic network selection mode in subclause 4.4.3.1.1 that are applicable to i), ii) and iii) with the exception of requirement a) and b) in subclause 4.4.3.1. Requirement a) and b) that are specified for automatic network selection mode in subclause 4.4.3.1 shall be ignored during the investigation scan.

If indicated on the SIM, the investigation scan shall be performed:

- i) After each successful PLMN selection and registration is completed, when the MS is in idle mode. This investigation scan may rely on the information from the already performed PLMN selection and may not necessarily require a rescan
- ii) When the MS is unable to obtain normal service from a PLMN, (limited service state) see subclause 3.5.

The investigation scan is restricted to automatic selection mode and shall only be performed by an MS that is capable of both voice and packet data. It shall only be performed if the selected PLMN is not already the highest prioritized PLMN in the current country. (HPLMN in home country, otherwise according to PLMN selector lists)

The MS shall return to RPLMN after the investigation scan is performed.

If a higher prioritized PLMN not offering GSM voice service is found, this shall be indicated to the user. The MS shall not select the PLMN unless requested by the user.

4.4.4 Abnormal cases

If there is no SIM in the MS, if there is an authentication failure, or if the MS receives an "IMSI unknown in HLR", "illegal ME" or "illegal MS" response to an LR request, then effectively there is no selected PLMN ("No SIM" state). In these cases, the states of the cell selection process are such that no PLMN selection information is used. No further attempts at registration on any PLMN are made until the MS is switched off and on again, or a SIM is inserted.

When in Automatic Network Selection mode and the MS is in the "not updated" state with one or more suitable cells to camp on; then after the maximum allowed unsuccessful LR requests (controlled by the specific attempt counters) the MS may continue (or start if it is not running) the user reselection procedure of 4.4.3.2 1.

4.4.5 Roaming not allowed in this LA

If in either PLMN selection mode the LR response "Roaming not allowed in this LA" is received:

The PLMN Automatic or Manual Mode Selection Procedure of subclause 4.4.3.1 are followed, depending on whether the MS is in automatic or manual mode. (This requirement applies to all MSs.)

4.5 Location registration process

4.5.1 General

When the MS is switched on and capable of services requiring registration, the action taken by the location registration process is as follows:

- a) SIM present and no LR needed (because of the status of the stored registration area identity and "attach" flag): The MS is in the update state UPDATED;
- b) SIM present and LR needed: A LR request is made;
- c) No SIM present: The MS enters the update state Idle, NO IMSI.

In case b) above, and subsequently whenever a LR request is made, the MS enters a state depending on the outcome of the LR request, as listed in subclause 4.3.2 above. In case c) the GPRS and the non-GPRS update state enters "IDLE, NO IMSI".

Whenever the MS goes to connected mode and then returns to idle mode again, the MS selects the appropriate state.

4.5.2 Initiation of Location Registration

An LR request indicating Normal Updating is made when, in idle mode,

- the MS changes cell while being in the update state NOT UPDATED; (for MS capable of GPRS and non-GPRS services when at least one of both update states is NOT UPDATED)
- the MS detects that it has entered a new registration area, i.e., when the received registration area identity differs from the one stored in the MS, and the LAI or the PLMN identity is not contained in a any of the lists of "forbidden LAIs for roaming", "forbidden LAs for regional provision of service", "forbidden PLMNs for GPRS service" or "forbidden PLMNs" identities respectively, while being in one of the following update states:
 - UPDATED;
 - NOT UPDATED;
 - ROAMING NOT ALLOWED.
- the Periodic Location Updating Timer expires while being in the non-GPRS update state NOT UPDATED (triggers Location Updating);
- the Periodic Routing Area Update timer expires while being in the GPRS update state NOT UPDATED (triggers Routing Area Update);
- a manual network reselection has been performed, an acceptable cell of the selected PLMN is present, and the MS is not in the UPDATED state on the selected PLMN.

An LR request indicating Periodic Location Updating is made when, in idle mode, the Periodic Location Updating timer expires while being in the non-GPRS update state UPDATED.

An LR request indicating Periodic Routing Area Update is made when the Periodic Routing Area Update timer expires while being in the GPRS update state UPDATED.

An LR request indicating IMSI attach is made when the MS is activated in the same location area in which it was deactivated while being in the non-GPRS update state UPDATED, and the system information indicates that IMSI attach/detach shall be used.

A GPRS attach is made by a GPRS MS when activated and capable of services which require registration. A GPRS attach may only performed if the selected PLMN is not contained in the list of "forbidden PLMNs for GPRS service". Depending on system information about GPRS network operation mode MSs operating in MS operation mode A or B perform combined or non-combined location registration procedures. When the combined routing area update or GPRS attach is accepted with indication "MSC not reachable" or is not answered the MS performs also the corresponding location updating procedure or falls back to a GPRS only MS. When the combined routing area update or GPRS attach is rejected with cause "GPRS not allowed" the GPRS update state is "IDLE, NO IMSI" and the MS performs the corresponding location updating procedure.

Furthermore, an LR request indicating Normal Location Updating is also made when the response to an outgoing request shows that the MS is unknown in the VLR or SGSN, respectively.

Table 2 in clause 5 summarizes the events in each state that trigger a new LR request. The actions that may be taken while being in the various states are also outlined in table 2.

A GPRS MS which is both IMSI attached for GPRS and non-GPRS services and which is capable of simultaneous operation of GPRS and non-GPRS services shall perform Routing Area Update in connected mode when it has entered a new routing area which is not part of a LA contained in the list of "forbidden LAIs for roaming" or "forbidden LAs for regional provision of service".

4.5.3 Periodic Location Registration

A Periodic Location Updating timer (for non-GPRS operation) and a Periodic Routing Area Update timer (for GPRS operation) with the following characteristics shall be implemented in the MS (MS capable of GPRS and non-GPRS operation shall implement both timers):

- i) Upon switch on of the MS or when the system information indicates that periodic location registration shall be applied, and the timer is not running, the timer shall be loaded with a random value between 0 and the broadcast or signalled time-out value and started.
- ii) The time-out value for the Periodic Location Updating timer shall be within the range of 1 deci-hour to 255 deci-hours with a granularity of 1 deci-hour.
- iii) When the timer reaches its expiry value, it shall be initiated with respect to the relevant time-out value, and the MS shall initiate the Periodic Location Registration corresponding to the expired timer.
- iv) The Periodic Location Updating timer shall be prevented from triggering Periodic Location Updating during connected mode. When the MS returns to idle mode, the Periodic Location Updating timer shall be initiated with respect to the broadcast time-out value, then started. Thereafter, the procedure in iii) shall be followed.
- v) The Periodic Routing Area Update timer shall be prevented from triggering the Periodic Routing Area Update during Ready state. At transition from Ready to Standby state the Periodic Routing Area Update timer shall be initiated with respect to its time-out value, then started. Thereafter, the procedure in iii) shall be followed.
- vi) If the MS performs a successful combined Routing Area Update the Periodic Location Updating timer shall be prevented from triggering the Periodic Location Updating until the MS starts using Location Updating procedure, for example because of a changed network operation mode or the MS uses non-GPRS services only.vii) When a change in the time-out value occurs (at a change of serving cell or a change in the broadcast time-out value or a change in the signalled time-out value), the related timer shall be reloaded so that the new time to expiry will be: "old time to expiry" modulo "new time-out value".

4.5.4 IMSI attach/detach operation

The system information will contain an indicator indicating whether or not IMSI attach/detach operation is mandatory to use in the cell. The MS shall operate in accordance with the received value of the indicator. A GPRS MS shall perform GPRS attach/detach procedures independent of the value of the IMSI attach/detach indicator. When a GPRS MS has to perform IMSI attach/detach independent of GPRS procedures (for example GPRS network operation mode 2) the handling described in the paragraph above applies.

When IMSI attach/detach operation applies, a MS shall send the IMSI detach message to the network when the MS is powered down or the SIM is removed while being in the update state UPDATED. The IMSI detach message will not be acknowledged by the network.

When the MS returns to the active state, the MS shall perform an LR request indicating IMSI attach, provided that the MS still is in the same registration area. If the registration area has changed, an LR request indicating Normal Location Updating according to subclause 4.5.2 shall be performed.

4.6 Service indication (A/Gb mode only)

This is an indication to the user that service or CTS service is available.

The service indication should be set if the following conditions are all satisfied:

- a) Cell Selection: Camped on a suitable cell and in updated state, or in connected mode having been camped on a suitable cell.

- b) Location registration: In updated state, for MSs capable of services requiring registration.

A specific CTS service indication should be set when the CTS MS is attached to a CTS FP. However due to the fact that there may be some transitory changes of state, the service indication is permitted to continue to be set for up to 10 seconds after the above conditions cease to be met. Also the service indication is permitted to take up to 1 second to be set after the above conditions are met.

4.7 Pageability of the mobile subscriber

An MS is required to listen to all paging messages that could address it (see 3GPP TS 05.02), when the following conditions are all satisfied:

- A SIM is inserted.
- The MS is camped on a cell.
- The MS is not in state "Idle, No IMSI".
- The MS is not performing the task to search for available PLMNs. (Whenever possible during this task, the MS should listen for paging.). However, when the MS is camped on a cell, is registered in a PLMN and is performing its regular search for the HPLMN, as specified in 3GPP TS 22.011, then it shall listen to all paging messages that could address it.

NOTE: In A/Gb mode, during cell reselection there is a certain period when the MS is no longer camped on the old cell but must decode the full BCCH or CPBCCH before camping on the new cell. This leads to a period of slightly more than 8 51 frame multiframes when the MS will not necessarily be pageable.

4.8 MM Restart Procedure

In some cases, e.g. on change of SIM data, there is a need for the MM to be restarted without the need for user intervention.

To perform the procedure the MS shall behave as if the SIM is removed and afterwards a new SIM is inserted.

5 Tables and Figures

Table 1: Effect of LR Outcomes on PLMN Registration

Location Registration Task State	Registration Status	Registered PLMN is
Updated	Successful	Indicated in the stored registration area identity
Idle, No IMSI	Unsuccessful	No registered PLMN (3)
Roaming not allowed:		
a) PLMN not allowed	Unsuccessful	No registered PLMN
b) LA not allowed	Indeterminate(1)	No registered PLMN
c) Roaming not allowed in this LA	Indeterminate (2)	No registered PLMN
Not updated	Unsuccessful	No registered PLMN

1) The MS will eventually either enter a different state when the registration status will be determined, or fail to be able to camp on a cell, when registration will be unsuccessful.

2) The MS will select the HPLMN if in automatic mode and will enter Automatic Network Selection Mode Procedure of subclause 4.4.3.1. If in manual mode, the MS will display the list of available PLMNs and follow the Manual Network Selection Mode Procedure of subclause 4.4.3.1.2 If the appropriate process does not result in registration, the MS will eventually enter the limited service state.

3) A MS may have different update states for GPRS and non-GPRS. A PLMN is registered when at least one of both update states is updated.

NOTE 1: MSs capable of GPRS and non-GPRS services may have different registration status for GPRS and for non-GPRS.

NOTE 2: The registered PLMN is determined by looking at the stored registration area identity and stored location registration status.

Table 2: LR Process States and Allowed Actions

Location registration task state	New LR request when				Normal Calls Supported (1)	Paging responded to
	Changing Cell	Changing registration area	Changing PLMN	Other		
Null (4)	No	Yes	Yes	No	No	No
Updated, (5)	No	Yes	Yes	(2)	Yes	Yes
Idle, No IMSI (7)	No	No	No	No	No	No
Roaming not allowed:						
a) Idle, PLMN not allowed	No	No	Yes	No	No	Optional if with IMSI
b) Idle, LA not allowed	No	Yes(6)	Yes	No	No	Optional if with IMSI
c) Idle, Roaming not allowed in this LA	No	Yes(6)	Yes	No	No	Optional if with IMSI
Not updated	Yes	Yes	Yes	(2)&(3)	(3)	Yes if with IMSI
<p>1): Emergency calls may always be made, subject to access control permitting it.</p> <p>2): A new LR is made when the periodic registration timer expires.</p> <p>3): If a normal call request is made, an LR request is made. If successful the updated state is entered and the call may be made.</p> <p>4): The MS is in the null state from switch on until it has camped on a cell and either made an LR attempt or decided that no LR attempt is needed.</p> <p>5): In this state, IMSI detach is performed if the MS is deactivated and the BCCH indicates that IMSI attach/detach shall be used. An LR request indicating IMSI attach is performed if the MS is activated in the same registration area in which it was deactivated while being in this state.</p> <p>6): A GPRS MS shall not perform a new LR when the new routing area is part of a LA contained in a <u>the list of "forbidden LAas for regional provision of service"</u>.</p> <p>7): The GPRS registration status "Idle, no IMSI" is entered when LR is rejected with cause "GPRS not allowed". The non-GPRS registration status „Idle, no IMSI“ is entered when the cause "IMSI unknown in HLR" is received.</p>						

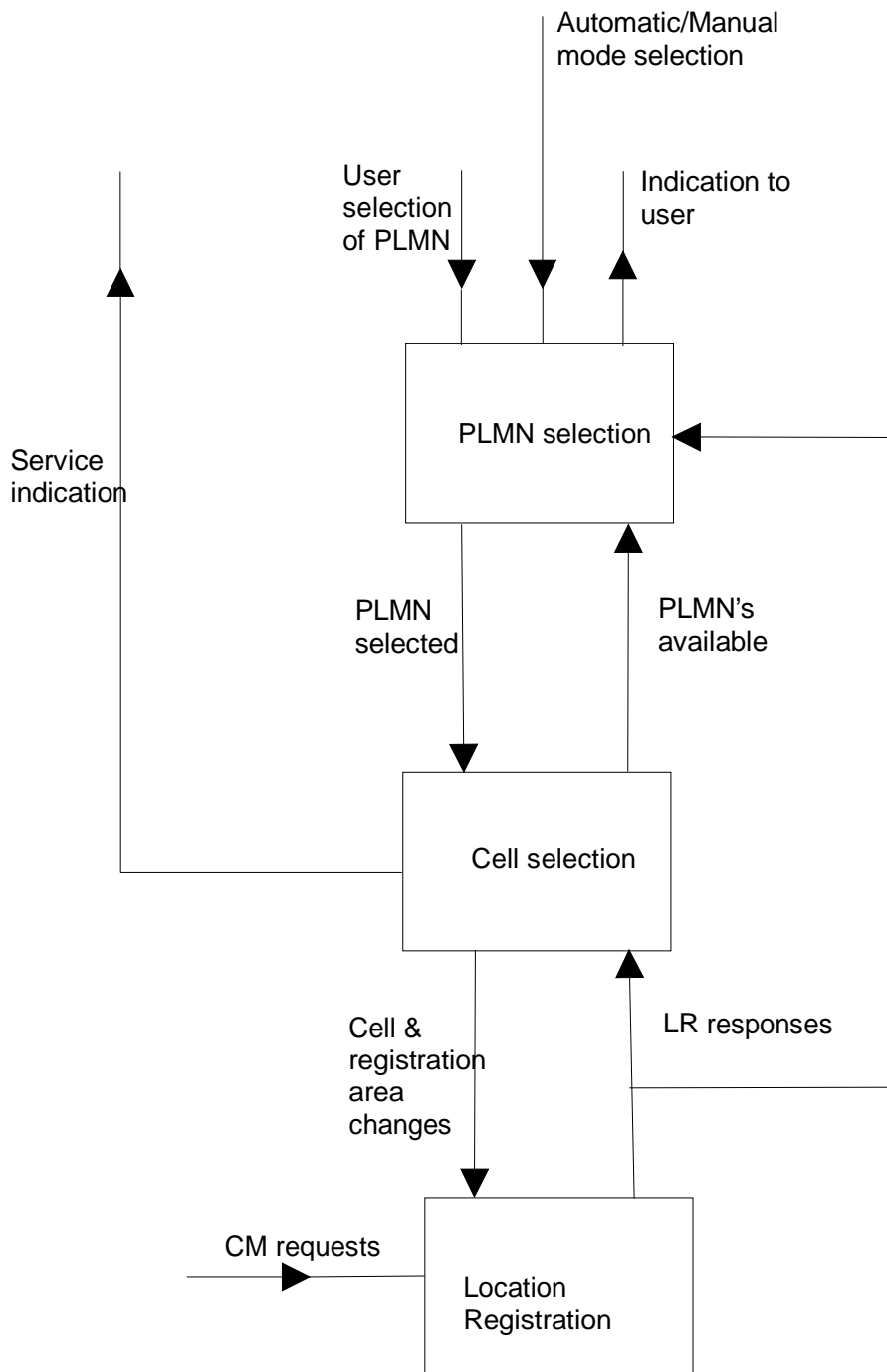
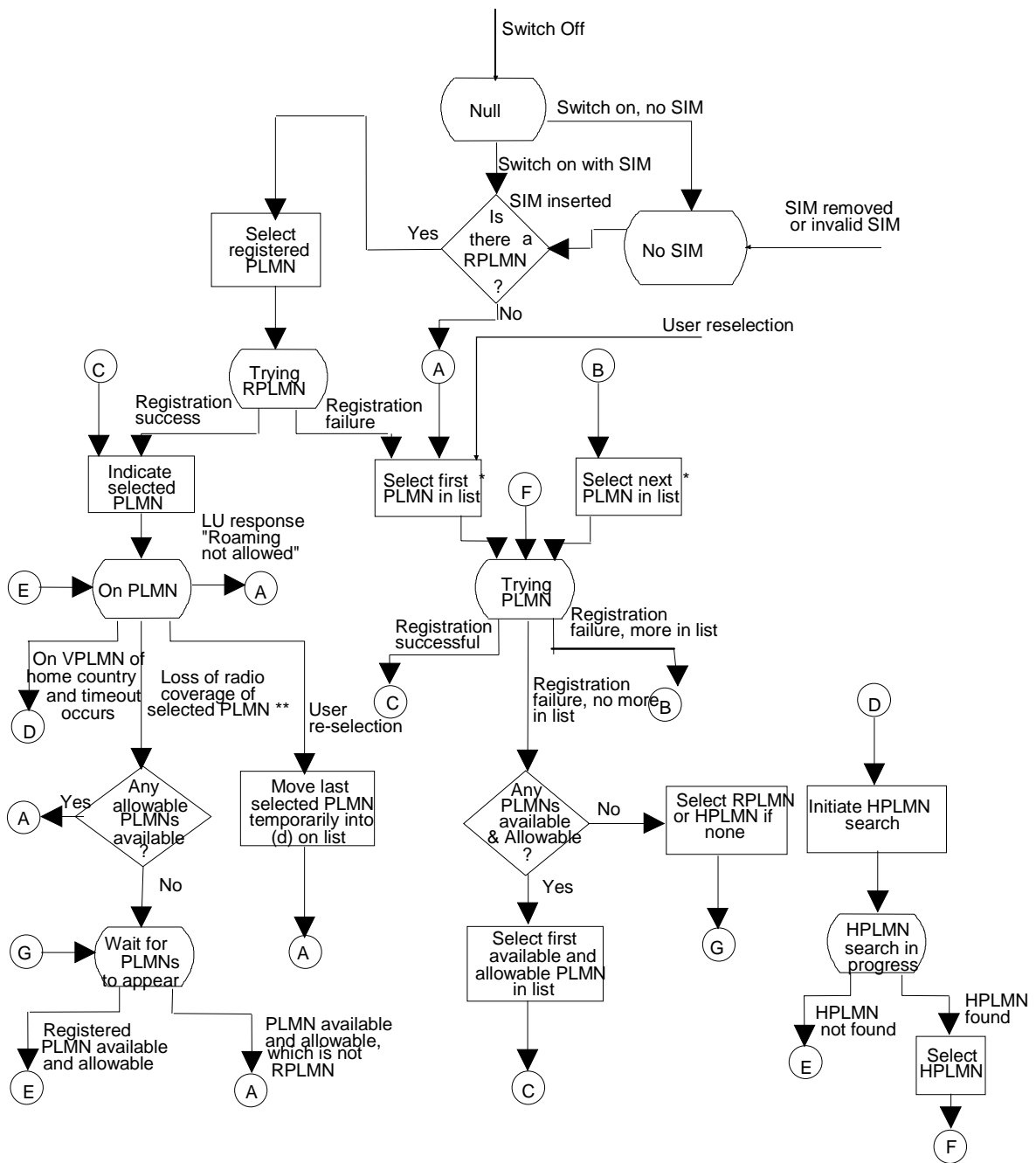

Figure 1: Overall Idle Mode process



* "List" consists of points i) to v) as defined in section 4.4.3.1.1 except in case of a user re-selection in which case "list" consists of points i) to vi) as defined in section 4.4.3.2.1

** Includes effective loss of coverage due to LAs being forbidden in all potentially suitable cells

Figure 2a: PLMN Selection State diagram (automatic mode)

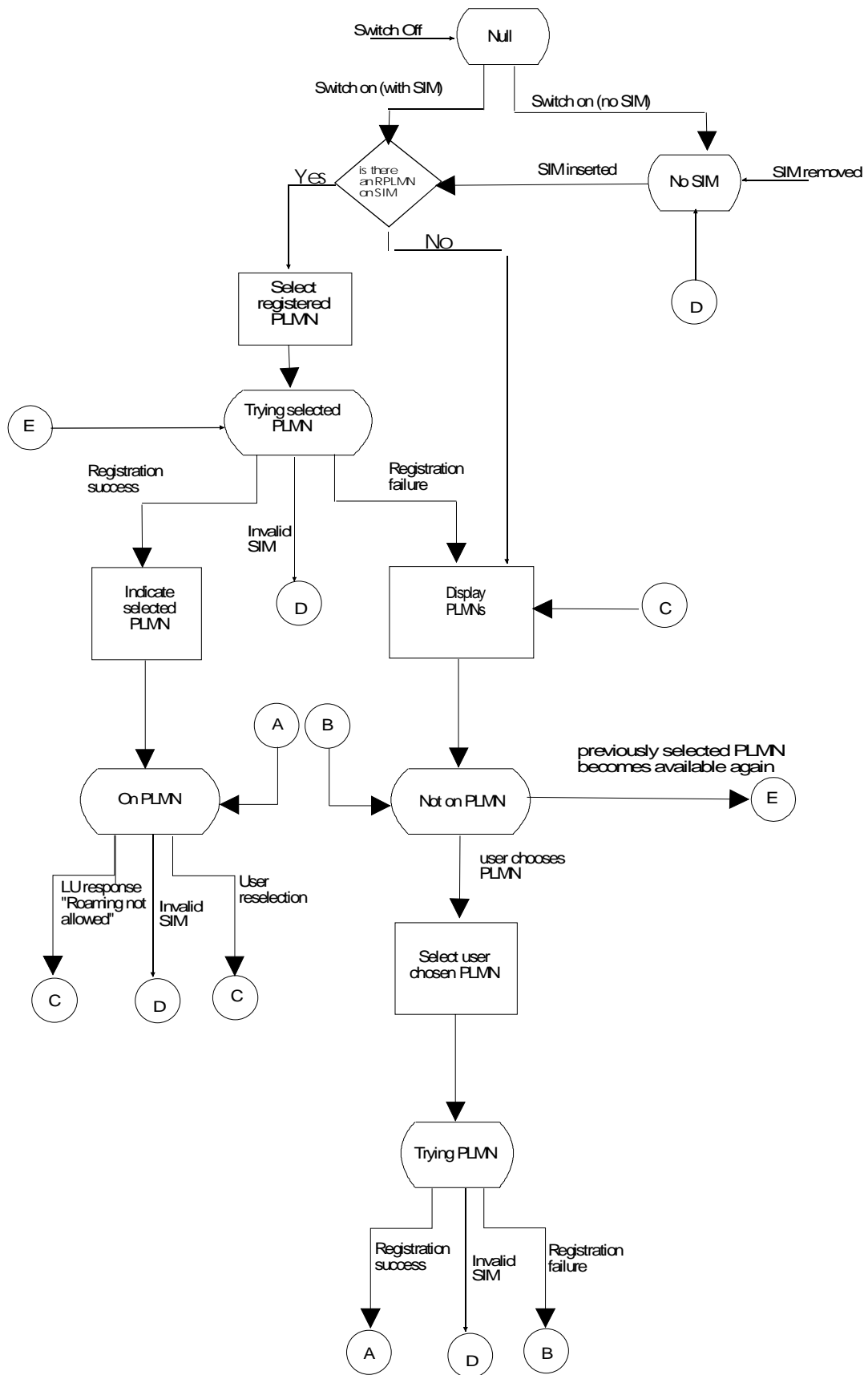
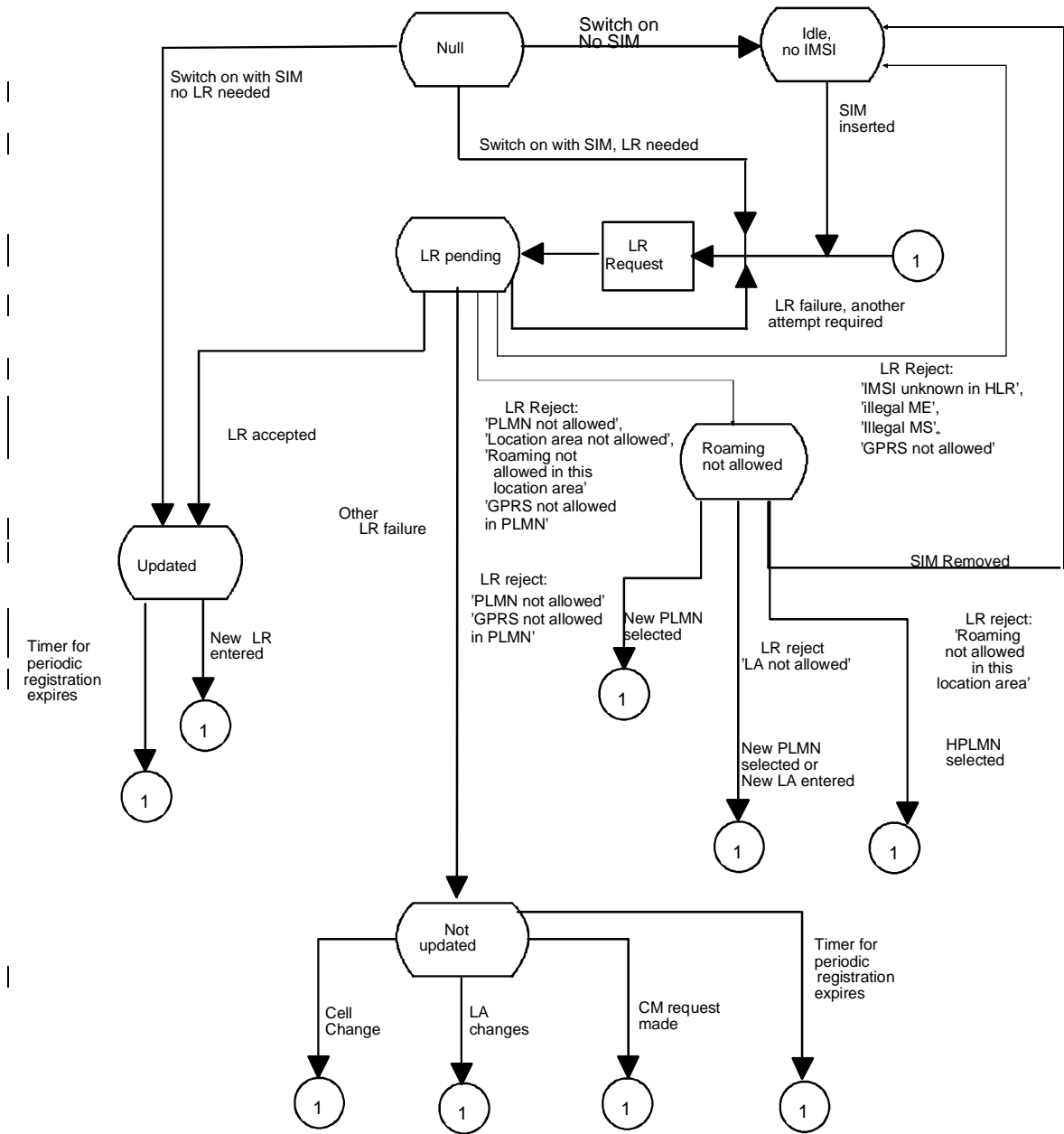

Figure 2b: PLMN Selection State diagram (manual mode)



NOTE 1: Whenever the MS goes to connected mode and then returns to idle mode again the MS selects appropriate state.

NOTE 2: A MS capable of GPRS and non-GPRS services has two Task State machines one for GPRS and one for non-GPRS operation.

Figure 3: Location Registration Task State diagram

Annex A (normative): HPLMN Matching Criteria

With the introduction of PCS1900 with the regulatory mandate to allocate 3-digit MNC codes, additional functionality is required to identify the HPLMN.

Assumptions

An MNC code shall consist of 2 or 3 decimal digits. In NA PCS1900, all SIMs shall store 3 digit MNCs. Any network using a 2 digit MNC code shall broadcast the hexadecimal code “F” in place of the 3rd digit. For PCS1900 for North America, regulations mandate that a 3-digit MNC shall be used; however during a transition period, a 2 digit MNC may be broadcast by the Network and, in this case, the 3rd digit of the SIM is stored as 0 (this is the 0 suffix rule).

With the exception of North America during the transition period:

- a) Within a single country (or area identified by a MCC) all networks shall broadcast a 2 digit MNC code, or all networks shall broadcast a 3 digit MNC code. A mixture of broadcast 2 and 3 digit MNC codes is not permitted within a single country (or area identified by a MCC).
- b) A network which broadcasts a 2 digit MNC code, will issue SIMs with a 2 digit MNC code in the IMSI on the SIM. A network which broadcasts a 3 digit MNC code, will issue SIMs with a 3 digit MNC code in the IMSI on the SIM.

Definitions and abbreviations

BCCH-MCC	The MCC part of the LAI read from System Information type 3 messages broadcast on the BCCH by the network.
BCCH-MNC	The MNC part of the LAI read from System Information type 3 messages broadcast on the BCCH by the network.
SIM-MCC	The MCC part of the IMSI read from the SIM.
SIM-MNC	The MNC part of the IMSI read from the SIM.

HPLMN Matching Criteria in mobiles which don't support PCS1900 for NA:

Figure A.1 illustrates the logic flow described below. The text below is normative. Figure A.1 is informative.

- (1) The MS shall compare using all 3 digits of the SIM-MCC with the BCCH-MCC. If the values do not match, then the HPLMN match fails.

NOTE: If the MCC codes match, then the number of digits used for the SIM-MNC must be the same as the number of digits used for the BCCH-MNC.

- (2) The MS shall read the 3rd digit of the BCCH-MNC. If the 3rd digit is Hex F, then proceed to step (4).
- (3) The MS shall compare using all 3 digits of the SIM-MNC with the BCCH-MNC. If the values match, then the HPLMN match succeeds, otherwise the HPLMN match fails.
- (4) The MS shall compare using just the 1st 2 digits the SIM-MNC with the BCCH-MNC. If the values match, then the HPLMN match succeeds, otherwise the HPLMN match fails.

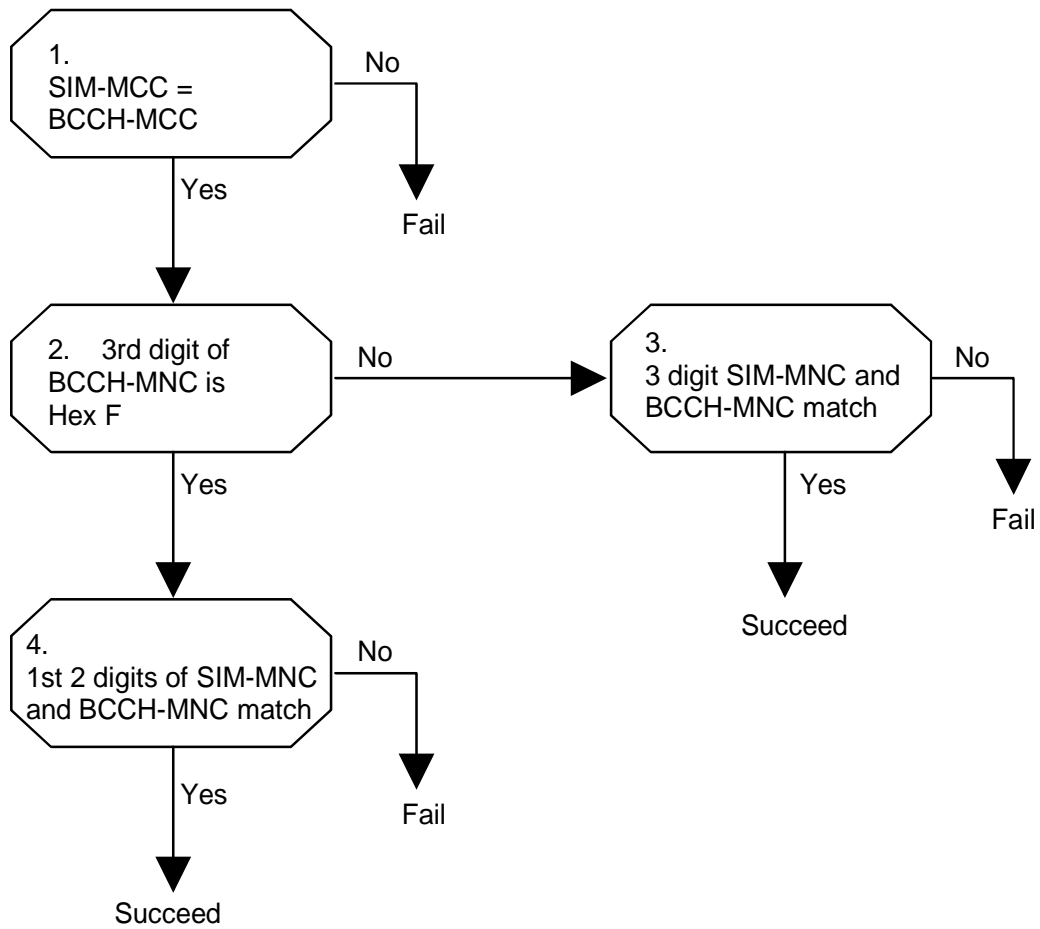

Figure A.1: HPLMN Matching Criteria Logic Flow for mobiles which support GSM and DCS1800 (informative)

HPLMN Matching Criteria for mobiles which support PCS1900 for NA:

Figure A.2 illustrates the logic flow described below. The text below is normative. Figure A.2 is informative.

- (1) The MS shall compare using all 3 digits the SIM-MCC with the BCCH-MCC. If the values do not match, then the HPLMN match fails.
- (2) The MS shall read the 3rd digit of the BCCH-MNC. If the 3rd digit is Hex F, then proceed to step (4).
- (3) The MS shall compare using all 3 digits the SIM-MNC with the BCCH-MNC. If the values match, then the HPLMN match succeeds, otherwise the HPLMN match fails.

NOTE: These rules (1) – (3) are the same as for mobiles which don't support PCS1900 for NA, except step (4) is different.

- (4) The MS shall determine if the BCCH-MCC lies in the range 310-316 (i.e., whether this network is a PCS1900 for NA network). If the BCCH-MCC lies outside the range 310-316, then proceed to step (6).
- (5) The MS shall compare the 3rd digit of the SIM-MNC with '0'. If the 3rd digit is not '0' then the HPLMN match fails.

NOTE: This is the '0' suffix rule.

- (6) The MS shall compare using just the 1st 2 digits of the SIM-MNC with the BCCH-MNC. If the values match, then the HPLMN match succeeds, otherwise the HPLMN match fails.

NOTE: When PCS1900 for NA switches over to broadcasting 3 digit MNCs in **all** networks, then the additional requirements for PCS1900 for NA can be deleted.

Guidance for Networks in PCS1900 for NA

There may be some problems in the transition period from broadcasting 2 MNC digits to broadcasting 3 MNC digits. Here are some guidelines to avoid these problems.

- (1) Existing network codes. Operators who currently use a 2 digit BCCH-MNC **xy** should use the new code **xy0**.
- (2) New operators allocated 3 digit MNC codes with the same 1st 2 digits as an existing operator shall not use a 3rd digit of 0.

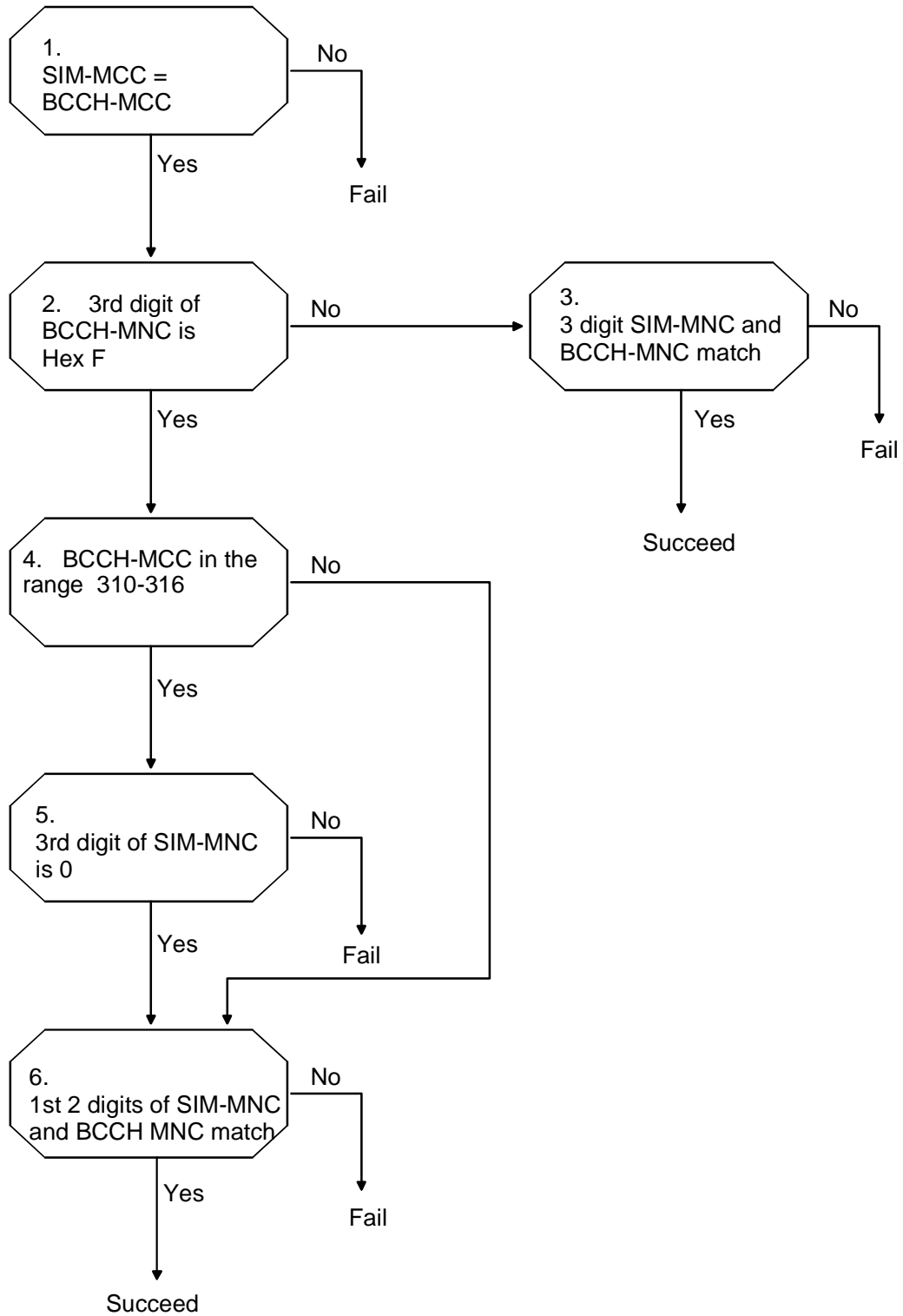

Figure A.2: HPLMN Matching Criteria Logic Flow for mobiles which support PCS1900 for NA (informative)

Annex B (normative): PLMN matching criteria to be of same country as VPLMN

While a MS is roaming on a VPLMN, PLMN of the same country as VPLMN is defined as:

- if the MCC of the current VPLMN is within the range 310 to 316, any PLMN in range 310 to 316 (networks in North America)
- otherwise, any PLMN with same MCC as the one of the current VPLMN itself.

Annex C (informative): Change history

TSG#	Tdoc	SPEC	VERS	CR	RE V	PHA SE	CA T	NEW _VER S	SUBJECT	comment
		03.22	8.2.0			R99			Split of 03.22/R99 to 03.22 and 23.122	
#6		23.122	0.0.0			R99		3.0.0		Was approved in the TSGN#6 plenary
#4	N1-99573	23.102	3.0.0	001		R99	F	3.1.0	PLMN selection for GPRS mobiles	Mirrored from CRA032r2 REMOVED in V3.1.1, where it is not approved by SMG2
#6	N1-99D13	23.122	3.0.0	002		R99	A	3.1.0	Correction of Figure A.2 in Annex A	Mirrored from CR006r1 for 23.022
#7	N1-000546	23.122	3.1.1	004	1	R99	D	3.2.0	UMTS references in 23.122	Correction of references
#8	N1-000796	23.122	3.2.0	003	5	R99	F	3.3.0	Modification of PLMN Selection Procedures to support UMTS+COMPACT Network Selection	WI: GSM / UMTS interworking Note As a result of two conflicting CRs N1-000796 is merged with the existing text in V.3.2.0 by the rapporteur
#9	NP-000443/ N1-001020	23.122	3.3.0	009	2	R99	F	3.4.0	Clarifications of the PLMN Selection procedures for UMTS and COMPACT.	
		23.122	3.4.0					3.4.1	Correction of text in version 3.4.0 (There was text to be deleted in section 4.4.3.2.1 bullet point 2)	23.Oct.2000 Implementation correction
		23.122	3.4.1					3.4.2	Correction of a systematic search for "TS" and replace it with "3GPP TS" has gone wrong as much more than the TSs for Technical Specifications have been changed also.	1 Nov..2000 Implementation correction
#10	NP-000674/ N1-001415	23.122	3.4.2	010	1	R99	F	3.5.0	Correction of terminology "In UMTS", "In GSM"	Cat F/ WI=TEI
#10	NP-000671/ N1-001236	23.122	3.4.2	012		R99	F	3.5.0	Restoration of figure A.1	Cat F/ WI=GSM - UMTS Interworking
#10	NP-000671/ N1-001237	23.122	3.4.2	013		R99	F	3.5.0	Alignment of figure 2a with PLMN selection for UMTS	Cat F/ WI=GSM - UMTS Interworking
#11	NP-010207/ N1-010472	23.122	3.5.0	014	3	R99	F	3.6.0	Clarification of the PLMN selection for UMTS regarding high quality signal	GSM - UMTS Interworking
#11	NP-010168/ N1-010224	23.122	3.5.0	016	1	R99	F	3.6.0	Roaming restrictions for GPRS service	GSM - UMTS Interworking
#11	NP-010205/ N1-010334	23.122	3.5.0	017		R99	F	3.6.0	remove use of GSM as default access technology in PLMN search	T.E.I
#11	NP-01089/ N1-010443	23.122	3.5.0	018		R99	F	3.6.0	Requirement of priority on High Quality Signal cell concerning Acceptable cell (for limited service as emergency call)	T.E.I
#11	NP-010186/ N1-010489	23.122	3.5.0	019	4	R99	F	3.6.0	Clarifications to PLMN search	T.E.I
#11	NP-010186/ N1-010490	23.122	3.5.0	020	1	R99	F	3.6.0	Clarifications to PLMN search	T.E.I
#11	NP-010180	23.122	3.5.0	022	1	R99	F	3.6.0	Equivalent handling of PLMNs with different PLMN codes	GSM - UMTS Interworking

CHANGE REQUEST

CR-Form-v3

⌘ **23.122 CR 027** ⌘ rev **1** ⌘ Current version: **4.0.0** ⌘

For **HELP** on using this form, see bottom of this page or look at the pop-up text over the ⌘ symbols.

Proposed change affects: ⌘ (U)SIM ME/UE Radio Access Network Core Network

Title: ⌘ Corrections and clarifications to PLMN Selection

Source: ⌘ Ericsson

Work item code: ⌘ GSM/UMTS Interworking

Date: ⌘ 2001-05-07

Category: ⌘ **A**

Release: ⌘ REL-4

Use one of the following categories:

F (essential correction)

A (corresponds to a correction in an earlier release)

B (Addition of feature),

C (Functional modification of feature)

D (Editorial modification)

Detailed explanations of the above categories can be found in 3GPP TR 21.900.

Use one of the following releases:

2 (GSM Phase 2)

R96 (Release 1996)

R97 (Release 1997)

R98 (Release 1998)

R99 (Release 1999)

REL-4 (Release 4)

REL-5 (Release 5)

Reason for change: ⌘ For the definition of Available PLMN's in chapter 1.2 in 23.122 certain conditions defined in 3GPP TS 03.22 are stated. We should avoid defining conditions in two different specifications and instead make a reference to 3GPP TS 03.22, as has been done for 3GPP TS 25.304.

The headlines in chapters 4.3.2 and 4.3.3, makes a reference to figure 4, but the reference should be corrected to figure 3 (as figure 4 does not exist in this specification).

Furthermore we have different forbidden lists today handling forbidden LAs and PLMNs. It is not always clearly stated what forbidden list the text in 23.122 refers to, especially not for lists of forbidden LAs. In addition, if an additional forbidden list is added in the future to this specification, 23.122 can get even more confusing.

The statement in chapter 3.2 "If the MS cannot find a suitable cell, the MS performs the PLMN selection procedure starting at subclause 4.4.3.1 A or B" should be deleted, as a cell in which the MS receives "LA not allowed" is still a suitable cell. The MS is not allowed any service in this cell and the MS will continue the cell re-selection in order to find a better cell, but the MS shall not trigger the PLMN selection until it has lost coverage. This CR proposes to delete this sentence as it is confusing. In addition we proposes to add the following sentence: "The MS shall camp on the cell for limited service." This aligns 23.122 with 22.011.

This CR also proposes to delete the sentence in chapter 4.4.5: "This requirement applies to all MSs" as the sentence is confusing. All requirements in this

specification applies to all mobiles, unless it is explicitly stated.

Summary of change: ⌘ References to sub-chapters in 03.22 are deleted.

Two references to figure 4 in chapters 4.3.2 and 4.3.3 are corrected to figure 3.

It has been clarified which forbidden list 23.122 refers to whenever the handling of the forbidden lists are described, to align with other specifications as 24.008.

The following sentence in chapter 3.2 has been deleted: "If the MS cannot find a suitable cell, the MS performs the PLMN selection procedure starting at subclause 4.4.3.1 A or B".

The following statement in chapter 4.4.5 has been deleted: "This requirement applies to all MSs".

Consequences if not approved: ⌘ The description of the LR reject cause values (and the behaviour of the registering MS) is unclear and not consistent with 22.011 and 24.008. Also the description (naming) of the forbidden lists is confusing.

Clauses affected: ⌘ 1.2, 3.1, 3.2, 4.3.2, 4.3.3, 4.4.5

Other specs Affected: ⌘ Other core specifications ⌘
 Test specifications
 O&M Specifications

Other comments: ⌘

1.2 Definitions and abbreviations

For the purposes of the present document the abbreviations given in 3GPP TS 01.04 and 3GPP TS 21.905 apply.

(A/Gb mode only): Indicates this clause or subclause applies only to GSM system. For multi system case this is determined by the current serving radio access network.

(Iu mode only): Indicates this clause or subclause applies only to UMTS system. For multi system case this is determined by the current serving radio access network.

Acceptable Cell: This is a cell that the MS may camp on to make emergency calls. It must satisfy criteria which is defined for A/Gb mode in 3GPP TS 03.22 and for Iu mode in 3GPP TS 25.304.

Access Technology: The access technology associated with a PLMN. The MS uses this information to determine what type of radio carrier to search for when attempting to select a specific PLMN (e.g., GSM, UMTS or GSM COMPACT). A PLMN may support more than one access technology.

Allowable PLMN: In the case of a MS operating in MS operation mode A or B, this is a PLMN which is not in the list of "forbidden PLMNs" in the MS.

In the case of a MS operating in MS operation mode C, this is a PLMN which is not in the list of "forbidden PLMNs" or in the list of "forbidden PLMNs for GPRS service" in the MS

Available PLMN: This is a PLMN where the MS has found a cell that satisfies conditions (ii) and (iv) of subclause 3.2.1 in 3GPP TS 03.22. For Iu mode the criteria is specified in 3GPP TS 25.304. For A/Gb mode this is a PLMN where the MS has found a cell that satisfies certain conditions specified in 3GPP TS 03.22. For Iu mode this is a PLMN where the MS has found a cell that satisfies certain conditions specified in 3GPP TS 25.304.

Camped on a cell: The MS (ME if there is no SIM) has completed the cell selection/reselection process and has chosen a cell from which it plans to receive all available services. Note that the services may be limited, and that the PLMN may not be aware of the existence of the MS (ME) within the chosen cell.

Current serving cell: This is the cell on which the MS is camped.

CTS MS: An MS capable of CTS services is a CTS MS.

GPRS MS: An MS capable of GPRS services is a GPRS MS.

MS operation mode See GSM 03.60[27].

High quality signal: The high quality signal limit is used in the PLMN selection procedure. It is defined in the appropriate AS specification: GSM TS 03.22 for the GSM radio access technology, 3G TS 25.304 for the UMTS radio access technology (FDD or TDD mode).

Home PLMN: This is a PLMN where the MCC and MNC of the PLMN identity match the MCC and MNC of the IMSI. Matching criteria are defined in Annex A.

In A/Gb mode,...: Indicates this paragraph applies only to GSM System. For multi system case this is determined by the current serving radio access network.

In Iu mode,...: Indicates this paragraph applies only to UMTS System. For multi system case this is determined by the current serving radio access network.

Localised Service Area (LSA): A localised service area consists of a cell or a number of cells. The cells constituting a LSA may not necessarily provide contiguous coverage.

Location Registration (LR): An MS which is IMSI attached to non-GPRS services only performs location registration by the Location Updating procedure. A GPRS MS which is IMSI attached to GPRS services or to GPRS and non-GPRS services performs location registration by the Routing Area Update procedure only when in a network of network operation mode I. Both procedures are performed independently by the GPRS MS when it is IMSI attached to GPRS and non-GPRS services in a network of network operation mode II or III (see 3GPP TS 23.060).

MS: Mobile Station. This specification makes no distinction between MS and UE.

Network Type: The network type associated with HPLMN or a PLMN on the PLMN selector (see GSM 11.11). The MS uses this information to determine what type of radio carrier to search for when attempting to select a specific PLMN. A PLMN may support more than one network type.

Registered PLMN (RPLMN): This is the PLMN on which certain LR outcomes have occurred (see table 1).

Registration: This is the process of camping on a cell of the PLMN and doing any necessary LRs.

Registration Area: A registration area is an area in which mobile stations may roam without a need to perform location registration. The registration area corresponds to location area (LA) for performing location updating procedure and it corresponds to routing area for performing the routing area update procedure.

The PLMN to which a cell belongs (PLMN identity) is given in the system information transmitted on the BCCH (MCC + MNC part of LAI).

Selected PLMN: This is the PLMN that has been selected according to subclause 3.1, either manually or automatically.

SIM: Subscriber Identity Module (see 3GPP TS 02.17). This specification makes no distinction between SIM and USIM.

SoLSA exclusive access: Cells on which normal camping is allowed only for MS with Localised Service Area (LSA) subscription.

Suitable Cell: This is a cell on which an MS may camp. It must satisfy criteria which is defined for A/Gb mode in 3GPP TS 03.22 and for Iu mode in 3GPP TS 25.304.

Visited PLMN of home country: This is a PLMN, different from the home PLMN, where the MCC part of the PLMN identity is the same as the MCC of the IMSI.

Visited PLMN: This is a PLMN, different from the home PLMN.

2 General description of idle mode

When an MS is switched on, it attempts to make contact with a public land mobile network (PLMN). The particular PLMN to be contacted may be selected either automatically or manually.

The MS looks for a suitable cell of the chosen PLMN and chooses that cell to provide available services, and tunes to its control channel. This choosing is known as "camping on the cell". The MS will then register its presence in the registration area of the chosen cell if necessary, by means of a location registration (LR), GPRS attach or IMSI attach procedure.

If the MS loses coverage of a cell, or find a more suitable cell, it reselects onto the most suitable cell of the selected PLMN and camps on that cell. If the new cell is in a different registration area, an LR request is performed.

If the MS loses coverage of a PLMN, either a new PLMN is selected automatically, or an indication of which PLMNs are available is given to the user, so that a manual selection can be made.

Registration is not performed by MSs only capable of services that need no registration.

The purpose of camping on a cell in idle mode is fourfold:

- a) It enables the MS to receive system information from the PLMN.
- b) If the MS wishes to initiate a call, it can do this by initially accessing the network on the control channel of the cell on which it is camped (with the exceptions defined in 3GPP TS 03.22 subclauses 3.5.3 and 3.5.4 and 3GPP TS 25.304).
- c) If the PLMN receives a call for the MS, it knows (in most cases) the registration area of the cell in which the MS is camped. It can then send a "paging" message for the MS on control channels of all the cells in the registration area. The MS will then receive the paging message because it is tuned to the control channel of a cell in that registration area, and the MS can respond on that control channel.
- d) It enables the MS to receive cell broadcast messages.

If the MS is unable to find a suitable cell to camp on, or the SIM is not inserted, or if it receives certain responses to an LR request (e.g., "illegal MS"), it attempts to camp on a cell irrespective of the PLMN identity, and enters a "limited service" state in which it can only attempt to make emergency calls.

In A/Gb mode, if the CTS MS is in CTS mode only or in automatic mode with CTS preferred, it will start by attempting to find a CTS fixed part on which it is enrolled

The idle mode tasks can be subdivided into 4 processes:

- PLMN selection;
- Cell selection and reselection;

- Location registration;
- CTS fixed part selection (A/Gb mode only).

In A/Gb mode, to make this initial CTS fixed part selection, the MS shall be enrolled on at least one fixed part.

The relationship between these processes is illustrated in figure 1 in clause 5. The states and state transitions within each process are shown in figures 2 to 4 in clause 5.

3 Requirements and technical solutions

The following subclauses list the main requirements of idle mode operation and give an outline of the technical solution.

3.1 PLMN selection and roaming

The MS normally operates on its home PLMN (HPLMN). However a visited PLMN (VPLMN) may be selected, e.g., if the MS loses coverage. There are two modes for PLMN selection:

- Automatic mode - This mode utilizes a list of PLMNs in priority order. The highest priority PLMN which is available and allowable is selected.
- Manual mode - Here the MS indicates to the user which PLMNs are available. Only when the user makes a manual selection does the MS try to obtain normal service on the VPLMN.

There are two cases:

- International Roaming - This is where the MS receives service on a PLMN of a different country than that of the HPLMN.
- National Roaming - This is where the MS receives service from a PLMN of the same country as that of the HPLMN, either anywhere or on a regional basis. The MS makes a periodic search for the HPLMN while national roaming.

To prevent repeated attempts to have roaming service on a not allowed LA, when the MS is informed that an LA is forbidden, the LA is added to a list of "forbidden LAs for roaming" which is stored in the MS. This list is deleted when the MS is switched off or when the SIM is removed. Such area restrictions are always valid for complete location areas independent of possible subdivision into GPRS routing areas. The structure of the routing area identifier (3GPP TS 23.003) supports area restriction on LA basis.

If a "PLMN not allowed" message is received by an MS in response to an LR request from a VPLMN, that VPLMN is added to a list of "forbidden PLMNs" in the SIM and thereafter that VPLMN will not be accessed by the MS when in automatic mode. A PLMN is removed from the "forbidden PLMNs" list if, after a subsequent manual selection of that PLMN, there is a successful LR. This list is retained when the MS is switched off or the SIM is removed. The HPLMN shall not be stored on the list of "forbidden PLMNs".

In A/Gb mode, an ME not supporting SoLSA may consider a cell with the escape PLMN code (see 3GPP TS 23.073) to be a part of a PLMN belonging to the list of "forbidden PLMNs".

Optionally the ME may store in its memory an extension of the "forbidden PLMNs" list. The contents of the extension of the list shall be deleted when the MS is switched off or the SIM is removed.

If a "GPRS services not allowed in this PLMN" message is received by an MS in response to an GPRS attach, GPRS detach or routing area update request from a VPLMN, that VPLMN is added to a list of "forbidden PLMNs for GPRS service" which is stored in the MS and thereafter that VPLMN will not be accessed by the MS for GPRS service when in automatic mode. This list is deleted when the MS is switched off or when the SIM is removed. A PLMN is removed from the list of "forbidden PLMNs for GPRS service" if, after a subsequent manual selection of that PLMN, there is a successful GPRS attach. The maximum number of possible entries in this list is implementation dependant, but must be at least one entry. The HPLMN shall not be stored on the list of "forbidden PLMNs for GPRS service".

3.2 Regional provision of service

An MS may have a "regionally restricted service" where it can only obtain service on certain LAs. If such an MS attempts to camp on a cell of an LA for which it does not have service entitlement, when it does an LR request, it will receive an "LA not allowed" message. In this case:

- The MS stores the forbidden LA identity (LAI) in a list of "forbidden LAIs for regional provision of service", to prevent repeated access attempts on a cell of the forbidden LA. This list is deleted when the MS is switched off or the SIM is removed. ~~If the MS cannot find a suitable cell, the MS performs the PLMN selection procedure starting at subclause 4.4.3.1 A or B. The MS enters the limited service state.~~

In A/Gb mode, a cell may be reserved for SoLSA exclusive access (see 3GPP TS 24.008 and 04.60). An MS is only allowed to camp normally on such a cell if it has a Localised Service Area subscription to the cell. Other MS may ~~enter camp for the limited service state.~~

- NOTE: In A/Gb mode, in a SoLSA exclusive cell the MCC+MNC code is replaced by an unique escape PLMN code (see 3GPP TS 23.073), not assigned to any PLMN, in SI3 and SI4. An MS not supporting SoLSA may request for location update to an exclusive access cell. In this case the location attempt is rejected with the cause "PLMN not allowed" and the escape PLMN code is added to the list of the "forbidden PLMNs".

3.3 Borders between registration areas

If the MS is moving in a border area between registration areas, it might repeatedly change between cells of different registration areas. Each change of registration area would require an LR, which would cause a heavy signalling load and increase the risk of a paging message being lost. The access stratum shall provide a mechanism to limit this effect.

3.4 Access control

3.4.1 Access control

Due to problems in certain areas, Network Operators may decide to restrict access from some MSs (e.g., in case of congestion), and for this reason an access control mechanism shall be provided.

3.4.2 Forbidden LA for regional provision of service

When the MS is camped on a cell, the LA of which belongs to the list of "forbidden LAs for regional provision of service", the MS is not allowed to initiate establishment of a CM connection except for an emergency call; it may respond to paging. Also, the MS is not allowed to request GPRS services when camped on a cell of a LA of which belongs to the list of "forbidden LAs for regional provision of service".

3.5 No suitable cell (limited service state)

There are a number of situations in which the MS is unable to obtain normal service from a PLMN. These include:

- a) Failure to find a suitable cell of the selected PLMN;
- b) No SIM in the MS;
- c) A "PLMN not allowed" response to an LR;
- d) An "illegal MS", "illegal ME" or "IMSI unknown in HLR" response to an LR; (Any SIM in the ME is then considered "invalid".)

- e) A "GPRS not allowed" response to an LR of a GPRS MS attached to GPRS services only. (The cell selection state of GPRS MSs attached to GPRS and non-GPRS depends on the outcome of the location updating.)

(In automatic PLMN selection mode, events (a), (c) and (e) would normally cause a new PLMN selection, but even here, the situation may arise when no PLMNs are available and allowable for use). Under any of these conditions, the MS attempts to camp on an acceptable cell, irrespective of its PLMN identity and giving priority to cell with received high quality signal, so that emergency calls can be made if necessary. When in the limited service state with a valid SIM, the MS shall search for available and allowable PLMNs in the manner described in subclause 4.4.3.1 and when indicated in the SIM also as described in subclause 4.4.3.4. No LR requests are made until a valid SIM is present and either a suitable cell is found or a manual network reselection is performed. In the limited service state the presence of the MS need not be known to the PLMN on whose cell it has camped.

NOTE: High quality signal is defined in the appropriate AS specification.

There are also other conditions under which only emergency calls may be made. These are shown in table 2 in clause 5.

3.6 CTS fixed part selection (A/Gb mode only)

In CTS mode only or in automatic mode with CTS preferred, the CTS MS normally operates on a CTS fixed part on which the mobile station is already enrolled. If the CTS MS loses CTS coverage in these modes, it shall attempt periodically to select again a CTS fixed part.

To select a CTS fixed part, the CTS MS shall listen to the CTSBCH frequencies of all the fixed parts on which the MS is currently enrolled.

If the CTS MS is moving in a border area between one area with CTS coverage and one without it, it might repeatedly require CTS attachments and LU on the PLMN. To prevent this, the criteria C1_CTS and C2_CTS (defined in 3GPP TS 05.08 subclause 11.1) are used. To attach to a CTS FP, the C1_CTS criterion shall be greater than zero. When the C2_CTS criterion falls below zero, the CTS MS shall consider itself to be no more under CTS coverage.

4 Overall process structure

4.1 Process goal

The aim of the idle mode processes is to ensure that the registered PLMN is the selected PLMN.

4.2 States description

Each of the processes of PLMN selection, cell selection and location registration can be described by a set of states. The overall state of the mobile is thus a composite of the states of the three processes. In some cases, an event which causes a change of state in one process may trigger a change of state in another process, e.g., camping on a cell in a new registration area triggers an LR request. The relationship between the processes is illustrated in figure 1 in clause 5.

The states in which the MS may be, for each of the processes, are described below and illustrated in figures 2 to 4 in clause 5. For many of the states, a fuller description can be found in other Technical Specifications, and a reference to the Technical Specification is given after the state description.

In the event of any conflict between the diagrams and the text in the present document, the text takes precedence.

4.3 List of states

4.3.1 List of states for the PLMN selection process

4.3.1.1 List of states for automatic mode (figure 2a)

- A1 Trying RPLMN - The MS is trying to perform a Location Registration on the registered PLMN.
- A2 On PLMN - The MS has successfully registered on a PLMN.
- A3 Trying PLMN - The MS is trying to register on a PLMN in the ordered list of PLMNs.
- A4 Wait for PLMNs to appear - There are no allowable and available PLMNs at present and the MS is waiting for one to appear.
- A5 HPLMN search in progress - The MS is trying to find if the HPLMN is available.
- A6 No SIM - There is no SIM in the MS, or certain LR responses have been received.

4.3.1.2 List of states for manual mode (figure 2b)

- M1 Trying registered PLMN - The MS is trying to perform a Location Registration on the registered PLMN.
- M2 On PLMN - The MS has successfully registered on a PLMN.
- M3 Not on PLMN - The MS has failed to register on the selected PLMN.
- M4 Trying PLMN - The MS is trying to register on a user selected PLMN.
- M5 No SIM - There is no SIM in the MS, or certain LR responses have been received.

4.3.2 List of states for location updating (figure 3.4)

The states are entered depending on responses to location update (LU) requests.

4.3.3 List of states for location registration (figure 3.4)

The states are entered depending on responses to location registration (LR) requests. Independent update states exist for GPRS and for non-GPRS operation in MSs capable of GPRS and non-GPRS services.

- L1 Updated - The MS enters this state if an LR request is accepted. The update status is set to "updated". The GPRS and the non-GPRS update state of a MS may enter "updated" as a result of combined signalling or as a result of individual signalling depending on the capabilities of the network.
- L2 Idle, No IMSI - The MS enters this state if an LR request is rejected with cause:
 - a) IMSI unknown in HLR;
 - b) illegal ME;
 - c) illegal MS;
 - d) GPRS services and non-GPRS services not allowed;

or if there is no SIM. All update states of a MS enter this state regardless whether received by individual or combined signalling for events b) and c). Event a) has no influence on the GPRS update state. Events b), c) and d) results in "Roaming not allowed" for the GPRS update state.

If a SIM is present, the non-GPRS update status of the SIM is set to "Roaming not allowed".

L3 Roaming not allowed - The MS enters this state if it receives an LU reject message with the cause:

- a) PLMN not allowed;
- b) Location area not allowed;
- c) Roaming not allowed in this location area.
- d) GPRS services not allowed in this PLMN

Except from event d) all update states of the MS are set to "Roaming not allowed" regardless whether received by individual or combined signalling. Event d) results in "Roaming not allowed" for the GPRS update state only. Event d) has no influence on the non-GPRS update state. The behaviour of the MS in the roaming not allowed state is dependent on the LR reject cause as shown in table 2 in clause 5. Additionally:

- in automatic mode, "PLMN not allowed" and "roaming not allowed in this location area" cause the Automatic Network Selection procedure of subclause 4.4.3.1.1 to be started; it is also caused by "GPRS services not allowed in this PLMN" when received by a GPRS MS operating in MS operation mode C;
- in manual mode, "PLMN not allowed" and "roaming not allowed" cause the Manual Network Selection procedure of subclause 4.4.3.1.2 to be started; it is also caused by "GPRS services not allowed in this PLMN" when received by a GPRS MS operating in MS operation mode C.

L4 Not updated - The MS enters this state if any LR failure not specified for states L2 or L3 occurs, in which cases the MS is not certain whether or not the network has received and accepted the LR attempt. The non-GPRS update status on the SIM and/or the GPRS update status are set to "not updated" depending on the specific location registration procedure and their outcome.

NOTE This clause does not describe all the cases. For more details refer to 3GPP TS 24.008 [23]

4.4 PLMN selection process

4.4.1 Introduction

There are two modes for PLMN selection, automatic and manual. These are described in subclauses 4.4.3 below and illustrated in figures 2a to 2b in clause 5.

4.4.2 Registration on a PLMN

The MS shall perform registration on the PLMN if the MS is capable of services which require registration. In both automatic and manual modes, the concept of registration on a PLMN is used. An MS successfully registers on a PLMN if:

- a) The MS has found a suitable cell of the PLMN to camp on; and

- b) An LR request from the MS has been accepted in the registration area of the cell on which the MS is camped (see table 1).

4.4.3 PLMN selection

The registration on the selected PLMN and the location registration are only necessary if the MS is capable of services which require registration. Otherwise, the PLMN selection procedures are performed without registration.

The “HPLMN Selector with Access Technology”, “User Controlled PLMN Selector with Access Technology” and “Operator Controlled PLMN Selector with Access Technology” data fields in the SIM include associated access technologies for each PLMN entry, see GSM 11.11 [32]. The PLMN/access technology combinations are listed in priority order. If an entry includes more than one access technology, then no priority is defined for the preferred access technology and the priority is an implementation issue. The Mobile Equipment stores a list of "equivalent PLMNs". This list is replaced or deleted at the end of each location update procedure, routing area update procedure and GPRS attach procedure. The stored list consists of a list of equivalent PLMNs as downloaded by the network plus the PLMN code of the network that downloaded the list. All PLMNs in the stored list are regarded as equivalent to each other for PLMN selection, cell selection/re-selection and handover.

The MS shall not use the PLMN codes contained in the “HPLMN Selector with Access Technology” data field.

NOTE: To allow provision for multiple HPLMN codes, the HPLMN access technologies are stored on the SIM together with PLMN codes. This version of the specification does not support multiple HPLMN codes and the “HPLMN Selector with Access Technology” data field is only used by the MS to get the HPLMN access technologies. The HPLMN code is the PLMN code included in the IMSI.

NOTE: Different GSM frequency bands (eg. 900, 1800, 1900, 400) are all considered GSM access technology. An MS supporting more than one band should scan all the bands it supports when scanning for GSM frequencies. However GSM COMPACT systems which use GSM frequency bands but with the CBPCCH broadcast channel are considered as a separate access technology from GSM.

4.4.3.1 At switch-on or recovery from lack of coverage

At switch on, or following recovery from lack of coverage, the MS selects the registered PLMN or equivalent PLMN (if it is available) using all access technologies that the MS is capable of and if necessary (in the case of recovery from lack of coverage, see subclause 4.5.2) attempts to perform a Location Registration.

EXCEPTION: In A/Gb mode or GSM COMPACT, an MS with voice capability, shall not search for CPBCCCH carriers, unless the “RPLMN Last Used Access Technology” field is available in the SIM and indicates GSM COMPACT. In A/Gb mode or GSM COMPACT, an MS not supporting packet services shall not search for CPBCCCH carriers.

If successful registration is achieved, the MS indicates the selected PLMN.

If there is no registered PLMN, or if registration is not possible due to the PLMN being unavailable or registration failure, the MS follows one of the following two procedures depending on its operating mode.

EXCEPTION: If registration is not possible on recovery from lack of coverage due to the registered PLMN being unavailable, a MS attached to GPRS services may, optionally, continue looking for the registered PLMN for an implementation dependent time.

NOTE 1: A MS attached to GPRS services should use the above exception only if one or more PDP contexts are currently active.

4.4.3.1.1 Automatic Network Selection Mode Procedure

The MS selects and attempts registration on other PLMNs, if available and allowable, in the following order:

- i) HPLMN (if not previously selected);
- ii) each PLMN in the "User Controlled PLMN Selector with Access Technology" data field in the SIM (in priority order);
- iii) each PLMN in the "Operator Controlled PLMN Selector with Access Technology" data field in the SIM (in priority order);
- iv) other PLMN/access technology combinations with received high quality signal in random order;
- v) other PLMN/access technology combinations in order of decreasing signal quality.

When following the above procedure the following requirements apply:

- a) In A/Gb mode or GSM COMPACT, an MS with voice capability shall ignore PLMNs for which the MS has identified at least one cell that do not offer voice service. (In A/Gb mode, this is indicated by the CELL_BAR_QUALIFY_2 parameter).
- b) In A/Gb mode or GSM COMPACT, an MS with voice capability, or an MS not supporting packet services shall not search for CPBCCCH carriers.
- c) In ii and iii, the MS should limit its search for the PLMN to the access technology or access technologies associated with the PLMN in the appropriate PLMN Selector with Access Technology list (User Controlled or Operator Controlled selector list). An MS using a SIM without access technology information storage (i.e. the "User Controlled PLMN Selector with Access Technology" and the "Operator Controlled PLMN Selector with Access Technology" data fields are not present) shall instead use the "PLMN Selector" data field, for each PLMN in the "PLMN Selector" data field, the MS shall search for all access technologies it is capable of and shall assume GSM access technology as the highest priority radio access technology.
- d) In iv and v, the MS shall search for all access technologies it is capable of, before deciding which PLMN to select.
- e) In ii, and iii, a packet only MS which supports GSM COMPACT, but using a SIM without access technology information storage (i.e. the "User Controlled PLMN Selector with Access Technology" and the "Operator Controlled PLMN Selector with Access Technology" data fields are not present) shall instead use the "PLMN Selector" data field, for each PLMN in the "PLMN Selector" data field, the MS shall search for all access technologies it is capable of and shall assume GSM COMPACT access technology as the lowest priority radio access technology.
- f) In i, the MS shall search for all access technologies it is capable of. The MS shall start its search using the access technologies stored in the "HPLMN Selector with Access Technology" data field on the SIM in priority order as defined in section 4.4.3 (i.e. the PLMN/access technology combinations are listed in priority order, if an entry includes more than one access technology then no priority is defined for the preferred access technology and the priority is an implementation issue).
- g) In i, an MS using a SIM without access technology information storage (i.e. the "HPLMN Selector with Access Technology" data field is not present) shall search for all access technologies it is capable of and shall assume GSM access technology as the highest priority radio access technology. A packet only MS which supports GSM COMPACT using a SIM without access technology information storage shall also assume GSM COMPACT access technology as the lowest priority radio access technology.
- h) In v, the MS shall order the PLMN/access technology combinations in order of decreasing signal quality within each access technology. The order between PLMN/access technology combinations with different access technologies is an MS implementation issue.

NOTE: Requirements a) and b) apply also to requirement d), so a GSM voice capable MS should not search for GSM COMPACT PLMNs, even if capable of GSM COMPACT.

NOTE: Requirements a) and b) apply also to requirement f), so a GSM voice capable MS should not search for GSM COMPACT PLMNs, even if this is the only access technology on the "HPLMN Selector with Access Technology" data field on the SIM. Also PLMNs not offering voice services should be ignored by voice capable GSM mobiles.

NOTE: High quality signal is defined in the appropriate AS specification.

If successful registration is achieved, the MS indicates the selected PLMN.

If registration cannot be achieved because no PLMNs are available and allowable, the MS indicates "no service" to the user, waits until a new PLMN is available and allowable and then repeats the procedure.

If there were one or more PLMNs which were available and allowable, but an LR failure made registration on those PLMNs unsuccessful or an entry in a [the "forbidden LAIs for regional provision of service"](#) list prevented a registration attempt, the MS selects the first such PLMN again and enters a limited service state.

4.4.3.1.2 Manual Network Selection Mode Procedure

The MS indicates whether there are any PLMNs, which are available using all supported access technologies. This includes [PLMNs in the "Forbidden PLMNs" list](#) and PLMNs which only offer services not supported by the MS. An MS which supports GSM COMPACT shall also indicate GSM COMPACT PLMNs (which use PBCCH).

If displayed, PLMNs meeting the criteria above are presented in the following order:

- i)- HPLMN;
- ii)- PLMNs contained in the "User Controlled PLMN Selector with Access Technology" data field in the SIM (in priority order);
- iii)- PLMNs contained in the "Operator Controlled PLMN Selector with Access Technology" data field in the SIM (in priority order);
- iv)- other PLMN/access technology combinations with received high quality signal in random order;
- v)- other PLMN/access technology combinations in order of decreasing signal quality.

In ii and iii, an MS using a SIM without access technology information storage (i.e. the "User Controlled PLMN Selector with Access Technology" and the "Operator Controlled PLMN Selector with Access Technology" data fields are not present) shall instead present the PLMNs contained in the "PLMN Selector" data field in the SIM (in priority order).

In v, requirement h) in section 4.4.3.1.1 applies.

In A/Gb mode or GSM COMPACT, if a PLMN does not support voice services then this shall be indicated to the user.

The user may select his desired PLMN and the MS then initiates registration on this PLMN using the access technology chosen by the user for that PLMN or using the highest priority available access technology for that PLMN, if the associated access technologies have a priority order. (This may take place at any time during the presentation of PLMNs). For such a registration, the MS shall ignore the contents of the ["forbidden LAIs lists for roaming"](#), ["forbidden LAIs for regional provision of service"](#), ["forbidden PLMNs for GPRS service"](#) lists and ["forbidden PLMNs"](#) lists.

NOTE: It is an MS implementation option whether to indicate access technologies to the user. If the MS does display access technologies, then the access technology used should be the access technology chosen by the user for that PLMN. If the MS does not display access technologies, then the access technology chosen for a particular PLMN should be the highest priority available access technology for that PLMN, if the associated access technologies have a priority order.

If the user does not select a PLMN, the selected PLMN shall be the one that was selected before the PLMN selection procedure started. If no such PLMN was selected or that PLMN is no longer available, then the MS shall attempt to camp on any acceptable giving priority to cell with received high quality signal cell and enter the limited service state.

NOTE: High quality signal is defined in the appropriate AS specification.

4.4.3.2 User reselection

At any time the user may request the MS to initiate reselection and registration onto an available PLMN, according to the following procedures, dependent upon the operating mode.

4.4.3.2.1 Automatic Network Selection Mode

The MS selects and attempts registration on PLMNs, if available and allowable, in all of its bands of operation in accordance with the following order:

- i) HPLMN;
- ii) PLMNs contained in the "User Controlled PLMN Selector with Access Technology" data field in the SIM (in priority order) excluding the previously selected PLMN;
- iii) PLMNs contained in the "Operator Controlled PLMN Selector with Access Technology" data field in the SIM (in priority order) excluding the previously selected PLMN;
- iv) other PLMN/access technology combinations with the received high quality signal in random order excluding the previously selected PLMN;
- v) other PLMN/access technology combinations, excluding the previously selected PLMN in order of decreasing signal quality or, alternatively, the previously selected PLMN may be chosen ignoring its signal quality;
- vi) The previously selected PLMN.

The previously selected PLMN is the PLMN which the MS has selected prior to the start of the user reselection procedure.

NOTE: If the previously selected PLMN is chosen, and registration has not been attempted on any other PLMNs, then the MS is already registered on the PLMN, and so registration is not necessary.

When following the above procedure the requirements a), b), c), e), f), g), h) in section 4.4.3.1.1 apply: Requirement d) shall apply as shown below:

- d) In iv, v, and vi, the MS shall search for all access technologies it is capable of before deciding which PLMN to select.

NOTE: High quality signal is defined in the appropriate AS specification.

4.4.3.2.2 Manual Network Selection Mode

The Manual Network Selection Mode Procedure of subclause 4.4.3.1.2 is followed.

4.4.3.3 In VPLMN

If the MS is in a VPLMN and the HPLMN is not in the stored list of equivalent PLMNs, the MS shall periodically attempt to obtain service on its HPLMN or higher priority PLMN listed in "user controlled PLMN selector" or "operator controlled PLMN selector" by scanning in accordance with the requirements that are applicable to i), ii) and iii) as defined in the Automatic Network Selection Mode in clause 4.4.3.1.1. In the case that the mobile has a stored "Equivalent PLMNs" list the mobile shall only select a PLMN if it is of a higher priority than any of those stored in the "Equivalent PLMNs" list. For this purpose, a value T minutes may be stored in the SIM, T is either in the range 6 minutes to 8 hours in 6 minute steps or it indicates that no periodic attempts shall be made. If no value is stored in the SIM, a default value of 60 minutes is used.

The attempts to access the HPLMN or higher priority PLMN shall be as specified below:

- a) The periodic attempts shall only be performed in automatic mode when the MS is roaming;
- b) After switch on, a period of at least 2 minutes and at most T minutes shall elapse before the first attempt is made;
- c) The MS shall make an attempt if the MS is on the VPLMN at time T after the last attempt;
- d) Periodic attempts shall only be performed by the MS while in idle mode;
- e) If the HPLMN or higher priority PLMN is not found, the MS shall remain on the VPLMN.
- f) In steps i), ii) and iii) the MS shall limit its attempts to access higher priority PLMNs to PLMNs of the same country as the current serving VPLMN.

4.4.3.4 Investigation Scan for higher prioritized PLMN

The support of this procedure is mandatory if the ME supports GSM COMPACT and otherwise optional. A MS capable of both GSM voice and packet service shall, when indicated in the SIM, investigate if there is service from a higher prioritized PLMN not offering GSM voice service, either HPLMN or a PLMN in a "PLMN Selector with Access Technology " data field on the SIM.

The MS shall scan for PLMNs in accordance with the requirements described for automatic network selection mode in subclause 4.4.3.1.1 that are applicable to i), ii) and iii) with the exception of requirement a) and b) in subclause 4.4.3.1. Requirement a) and b) that are specified for automatic network selection mode in subclause 4.4.3.1 shall be ignored during the investigation scan.

If indicated on the SIM, the investigation scan shall be performed:

- i) After each successful PLMN selection and registration is completed, when the MS is in idle mode. This investigation scan may rely on the information from the already performed PLMN selection and may not necessarily require a rescan
- ii) When the MS is unable to obtain normal service from a PLMN, (limited service state) see subclause 3.5.

The investigation scan is restricted to automatic selection mode and shall only be performed by an MS that is capable of both voice and packet data. It shall only be performed if the selected PLMN is not already the highest prioritized PLMN in the current country. (HPLMN in home country, otherwise according to PLMN selector lists)

The MS shall return to RPLMN after the investigation scan is performed.

If a higher prioritized PLMN not offering GSM voice service is found, this shall be indicated to the user.

The MS shall not select the PLMN unless requested by the user.

4.4.4 Abnormal cases

If there is no SIM in the MS, if there is an authentication failure, or if the MS receives an "IMSI unknown in HLR", "illegal ME" or "illegal MS" response to an LR request, then effectively there is no selected PLMN ("No SIM" state). In these cases, the states of the cell selection process are such that no PLMN selection information is used. No further attempts at registration on any PLMN are made until the MS is switched off and on again, or a SIM is inserted.

When in Automatic Network Selection mode and the MS is in the "not updated" state with one or more suitable cells to camp on; then after the maximum allowed unsuccessful LR requests (controlled by the specific attempt counters) the MS may continue (or start if it is not running) the user reselection procedure of 4.4.3.2 1.

4.4.5 Roaming not allowed in this LA

If in either PLMN selection mode the LR response "Roaming not allowed in this LA" is received:

The PLMN Automatic or Manual Mode Selection Procedure of subclause 4.4.3.1 are followed, depending on whether the MS is in automatic or manual mode. ~~(This requirement applies to all MSs.)~~

4.5 Location registration process

4.5.1 General

When the MS is switched on and capable of services requiring registration, the action taken by the location registration process is as follows:

- a) SIM present and no LR needed (because of the status of the stored registration area identity and "attach" flag): The MS is in the update state UPDATED;
- b) SIM present and LR needed: A LR request is made;
- c) No SIM present: The MS enters the update state Idle, NO IMSI.

In case b) above, and subsequently whenever a LR request is made, the MS enters a state depending on the outcome of the LR request, as listed in subclause 4.3.2 above. In case c) the GPRS and the non-GPRS update state enters "IDLE, NO IMSI".

Whenever the MS goes to connected mode and then returns to idle mode again, the MS selects the appropriate state.

4.5.2 Initiation of Location Registration

An LR request indicating Normal Updating is made when, in idle mode,

- the MS changes cell while being in the update state NOT UPDATED; (for MS capable of GPRS and non-GPRS services when at least one of both update states is NOT UPDATED)
- the MS detects that it has entered a new registration area, i.e., when the received registration area identity differs from the one stored in the MS, and the LAI or the PLMN identity is not contained in a any of the lists of "forbidden LAIs for roaming", "forbidden LAs for regional provision of service", "forbidden PLMNs for GPRS service" or "forbidden PLMNs" identities respectively, while being in one of the following update states:
 - UPDATED;
 - NOT UPDATED;
 - ROAMING NOT ALLOWED.
- the Periodic Location Updating Timer expires while being in the non-GPRS update state NOT UPDATED (triggers Location Updating);
- the Periodic Routing Area Update timer expires while being in the GPRS update state NOT UPDATED (triggers Routing Area Update);
- a manual network reselection has been performed, an acceptable cell of the selected PLMN is present, and the MS is not in the UPDATED state on the selected PLMN.

An LR request indicating Periodic Location Updating is made when, in idle mode, the Periodic Location Updating timer expires while being in the non-GPRS update state UPDATED.

An LR request indicating Periodic Routing Area Update is made when the Periodic Routing Area Update timer expires while being in the GPRS update state UPDATED.

An LR request indicating IMSI attach is made when the MS is activated in the same location area in which it was deactivated while being in the non-GPRS update state UPDATED, and the system information indicates that IMSI attach/detach shall be used.

A GPRS attach is made by a GPRS MS when activated and capable of services which require registration. A GPRS attach may only be performed if the selected PLMN is not contained in the list of "forbidden PLMNs for GPRS service". Depending on system information about GPRS network operation mode MSs operating in MS operation mode A or B perform combined or non-combined location registration procedures. When the combined routing area update or GPRS attach is accepted with indication "MSC not reachable" or is not answered the MS performs also the corresponding location updating procedure or falls back to a GPRS only MS. When the combined routing area update or GPRS attach is rejected with cause "GPRS not allowed" the GPRS update state is "IDLE, NO IMSI" and the MS performs the corresponding location updating procedure.

Furthermore, an LR request indicating Normal Location Updating is also made when the response to an outgoing request shows that the MS is unknown in the VLR or SGSN, respectively.

Table 2 in clause 5 summarizes the events in each state that trigger a new LR request. The actions that may be taken while being in the various states are also outlined in table 2.

A GPRS MS which is both IMSI attached for GPRS and non-GPRS services and which is capable of simultaneous operation of GPRS and non-GPRS services shall perform Routing Area Update in connected mode when it has entered a new routing area which is not part of a LA contained in the list of "forbidden LAIs for roaming" or "forbidden LAs for regional provision of service".

4.5.3 Periodic Location Registration

A Periodic Location Updating timer (for non-GPRS operation) and a Periodic Routing Area Update timer (for GPRS operation) with the following characteristics shall be implemented in the MS (MS capable of GPRS and non-GPRS operation shall implement both timers):

- i) Upon switch on of the MS or when the system information indicates that periodic location registration shall be applied, and the timer is not running, the timer shall be loaded with a random value between 0 and the broadcast or signalled time-out value and started.
- ii) The time-out value for the Periodic Location Updating timer shall be within the range of 1 deci-hour to 255 deci-hours with a granularity of 1 deci-hour.
- iii) When the timer reaches its expiry value, it shall be initiated with respect to the relevant time-out value, and the MS shall initiate the Periodic Location Registration corresponding to the expired timer.
- iv) The Periodic Location Updating timer shall be prevented from triggering Periodic Location Updating during connected mode. When the MS returns to idle mode, the Periodic Location Updating timer shall be initiated with respect to the broadcast time-out value, then started. Thereafter, the procedure in iii) shall be followed.
- v) The Periodic Routing Area Update timer shall be prevented from triggering the Periodic Routing Area Update during Ready state. At transition from Ready to Standby state the Periodic Routing Area Update timer shall be initiated with respect to its time-out value, then started. Thereafter, the procedure in iii) shall be followed.
- vi) If the MS performs a successful combined Routing Area Update the Periodic Location Updating timer shall be prevented from triggering the Periodic Location Updating until the MS starts using Location Updating procedure, for example because of a changed network operation mode or the MS uses non-GPRS services only.vii) When a change in the time-out value occurs (at a change of serving cell or a change in the broadcast time-out value or a change in the signalled time-out value),

the related timer shall be reloaded so that the new time to expiry will be: "old time to expiry" modulo "new time-out value".

4.5.4 IMSI attach/detach operation

The system information will contain an indicator indicating whether or not IMSI attach/detach operation is mandatory to use in the cell. The MS shall operate in accordance with the received value of the indicator. A GPRS MS shall perform GPRS attach/detach procedures independent of the value of the IMSI attach/detach indicator. When a GPRS MS has to perform IMSI attach/detach independent of GPRS procedures (for example GPRS network operation mode 2) the handling described in the paragraph above applies.

When IMSI attach/detach operation applies, a MS shall send the IMSI detach message to the network when the MS is powered down or the SIM is removed while being in the update state UPDATED. The IMSI detach message will not be acknowledged by the network.

When the MS returns to the active state, the MS shall perform an LR request indicating IMSI attach, provided that the MS still is in the same registration area. If the registration area has changed, an LR request indicating Normal Location Updating according to subclause 4.5.2 shall be performed.

4.6 Service indication (A/Gb mode only)

This is an indication to the user that service or CTS service is available.

The service indication should be set if the following conditions are all satisfied:

- a) Cell Selection: Camped on a suitable cell and in updated state, or in connected mode having been camped on a suitable cell.
- b) Location registration: In updated state, for MSs capable of services requiring registration.

A specific CTS service indication should be set when the CTS MS is attached to a CTS FP.

However due to the fact that there may be some transitory changes of state, the service indication is permitted to continue to be set for up to 10 seconds after the above conditions cease to be met. Also the service indication is permitted to take up to 1 second to be set after the above conditions are met.

4.7 Pageability of the mobile subscriber

An MS is required to listen to all paging messages that could address it (see 3GPP TS 05.02), when the following conditions are all satisfied:

- A SIM is inserted.
- The MS is camped on a cell.
- The MS is not in state "Idle, No IMSI".
- The MS is not performing the task to search for available PLMNs. (Whenever possible during this task, the MS should listen for paging.) However, when the MS is camped on a cell, is registered in a PLMN and is performing its regular search for the HPLMN, as specified in 3GPP TS 22.011, then it shall listen to all paging messages that could address it.

NOTE: In A/Gb mode, during cell reselection there is a certain period when the MS is no longer camped on the old cell but must decode the full BCCH or CPBCCH before camping on the new cell. This leads to a period of slightly more than 8 51 frame multiframe when the MS will not necessarily be pageable.

4.8 MM Restart Procedure

In some cases, e.g. on change of SIM data, there is a need for the MM to be restarted without the need for user intervention.

To perform the procedure the MS shall behave as if the SIM is removed and afterwards a new SIM is inserted.

5 Tables and Figures

Table 1: Effect of LR Outcomes on PLMN Registration

Location Registration Task State	Registration Status	Registered PLMN is
Updated	Successful	Indicated in the stored registration area identity
Idle, No IMSI	Unsuccessful	No registered PLMN (3)
Roaming not allowed:		
a) PLMN not allowed	Unsuccessful	No registered PLMN
b) LA not allowed	Indeterminate(1)	No registered PLMN
c) Roaming not allowed in this LA	Indeterminate (2)	No registered PLMN
Not updated	Unsuccessful	No registered PLMN

1) The MS will eventually either enter a different state when the registration status will be determined, or fail to be able to camp on a cell, when registration will be unsuccessful.

2) The MS will select the HPLMN if in automatic mode and will enter Automatic Network Selection Mode Procedure of subclause 4.4.3.1. If in manual mode, the MS will display the list of available PLMNs and follow the Manual Network Selection Mode Procedure of subclause 4.4.3.1.2 If the appropriate process does not result in registration, the MS will eventually enter the limited service state.

3) A MS may have different update states for GPRS and non-GPRS. A PLMN is registered when at least one of both update states is updated.

NOTE 1: MSs capable of GPRS and non-GPRS services may have different registration status for GPRS and for non-GPRS.

NOTE 2: The registered PLMN is determined by looking at the stored registration area identity and stored location registration status.

Table 2: LR Process States and Allowed Actions

Location registration task state	New LR request when				Normal Calls Supported (1)	Paging responded to
	Changing Cell	Changing registration area	Changing PLMN	Other		
Null (4)	No	Yes	Yes	No	No	No
Updated, (5)	No	Yes	Yes	(2)	Yes	Yes
Idle, No IMSI (7)	No	No	No	No	No	No
Roaming not allowed:						
a) Idle, PLMN not allowed	No	No	Yes	No	No	Optional if with IMSI
b) Idle, LA not allowed	No	Yes(6)	Yes	No	No	Optional if with IMSI
c) Idle, Roaming not allowed in this LA	No	Yes(6)	Yes	No	No	Optional if with IMSI
Not updated	Yes	Yes	Yes	(2)&(3)	(3)	Yes if with IMSI
<p>1): Emergency calls may always be made, subject to access control permitting it.</p> <p>2): A new LR is made when the periodic registration timer expires.</p> <p>3): If a normal call request is made, an LR request is made. If successful the updated state is entered and the call may be made.</p> <p>4): The MS is in the null state from switch on until it has camped on a cell and either made an LR attempt or decided that no LR attempt is needed.</p> <p>5): In this state, IMSI detach is performed if the MS is deactivated and the BCCH indicates that IMSI attach/detach shall be used. An LR request indicating IMSI attach is performed if the MS is activated in the same registration area in which it was deactivated while being in this state.</p> <p>6): A GPRS MS shall not perform a new LR when the new routing area is part of a LA contained in a <u>the list of "forbidden LAs for regional provision of service"</u>.</p> <p>7): The GPRS registration status "Idle, no IMSI" is entered when LR is rejected with cause "GPRS not allowed". The non-GPRS registration status „Idle, no IMSI“ is entered when the cause "IMSI unknown in HLR" is received.</p>						

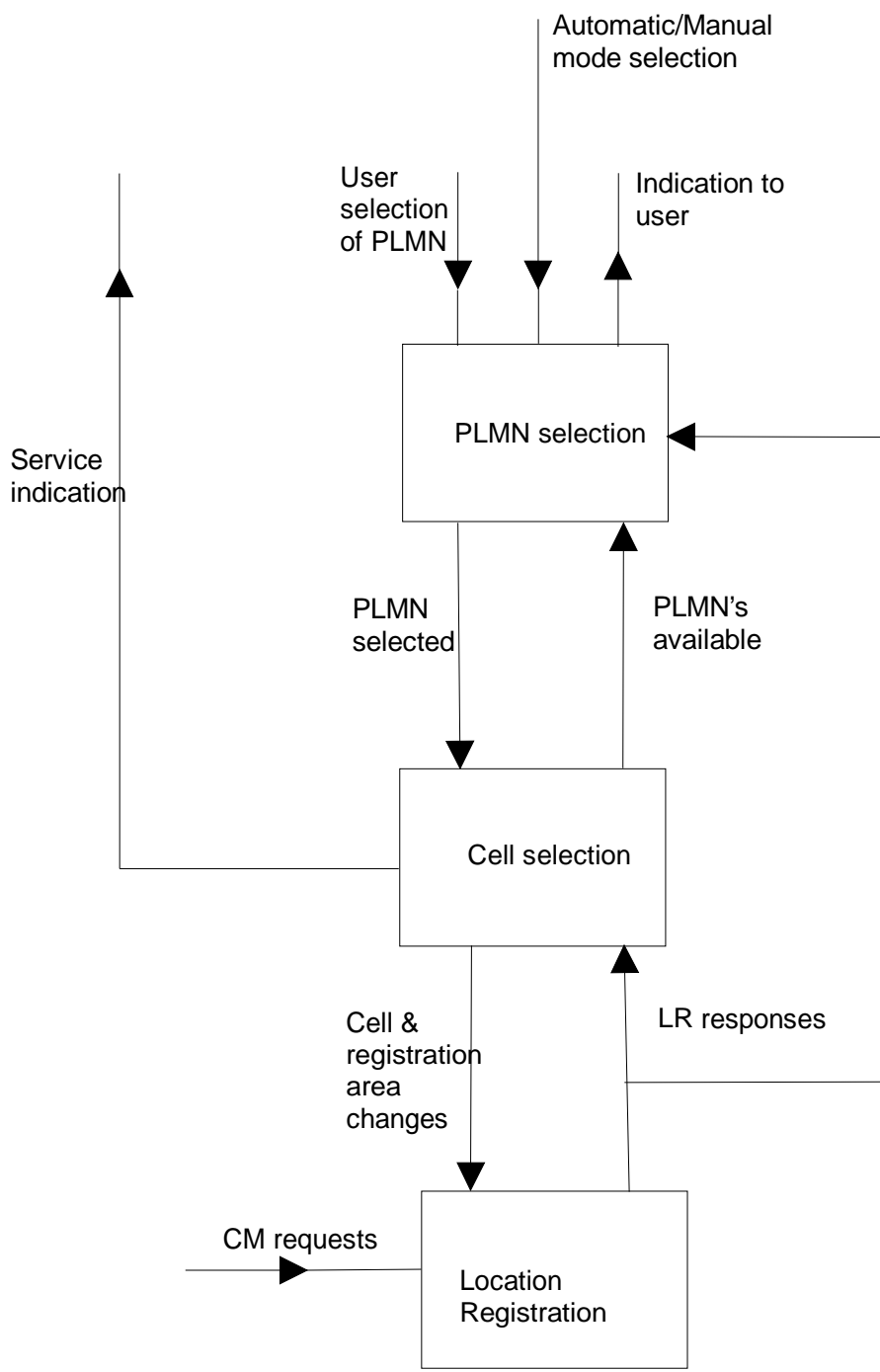
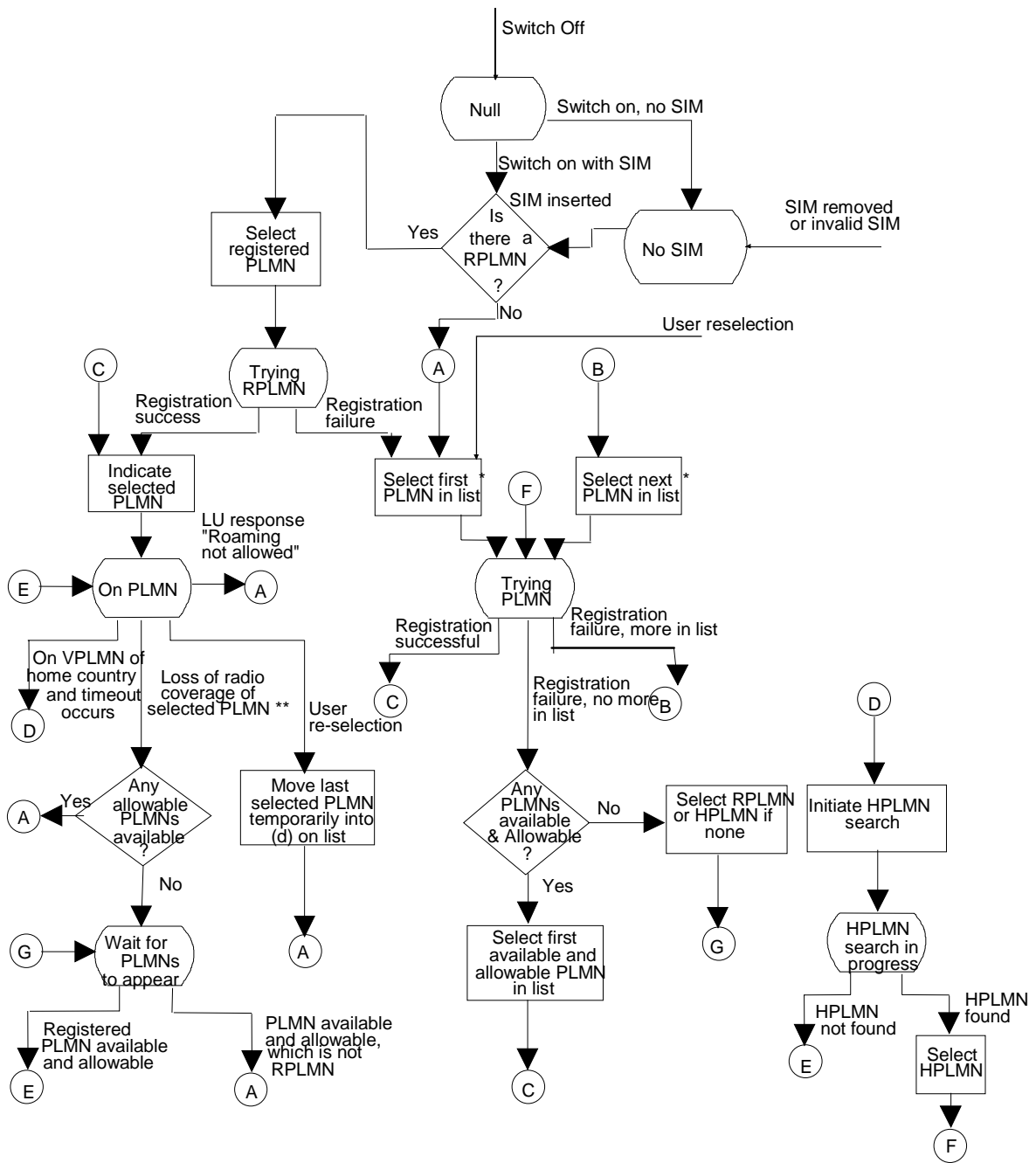

Figure 1: Overall Idle Mode process



* "List" consists of points i) to v) as defined in section 4.4.3.1.1 except in case of a user re-selection in which case "list" consists of points i) to vi) as defined in section 4.4.3.2.1

** Includes effective loss of coverage due to LAs being forbidden in all potentially suitable cells

Figure 2a: PLMN Selection State diagram (automatic mode)

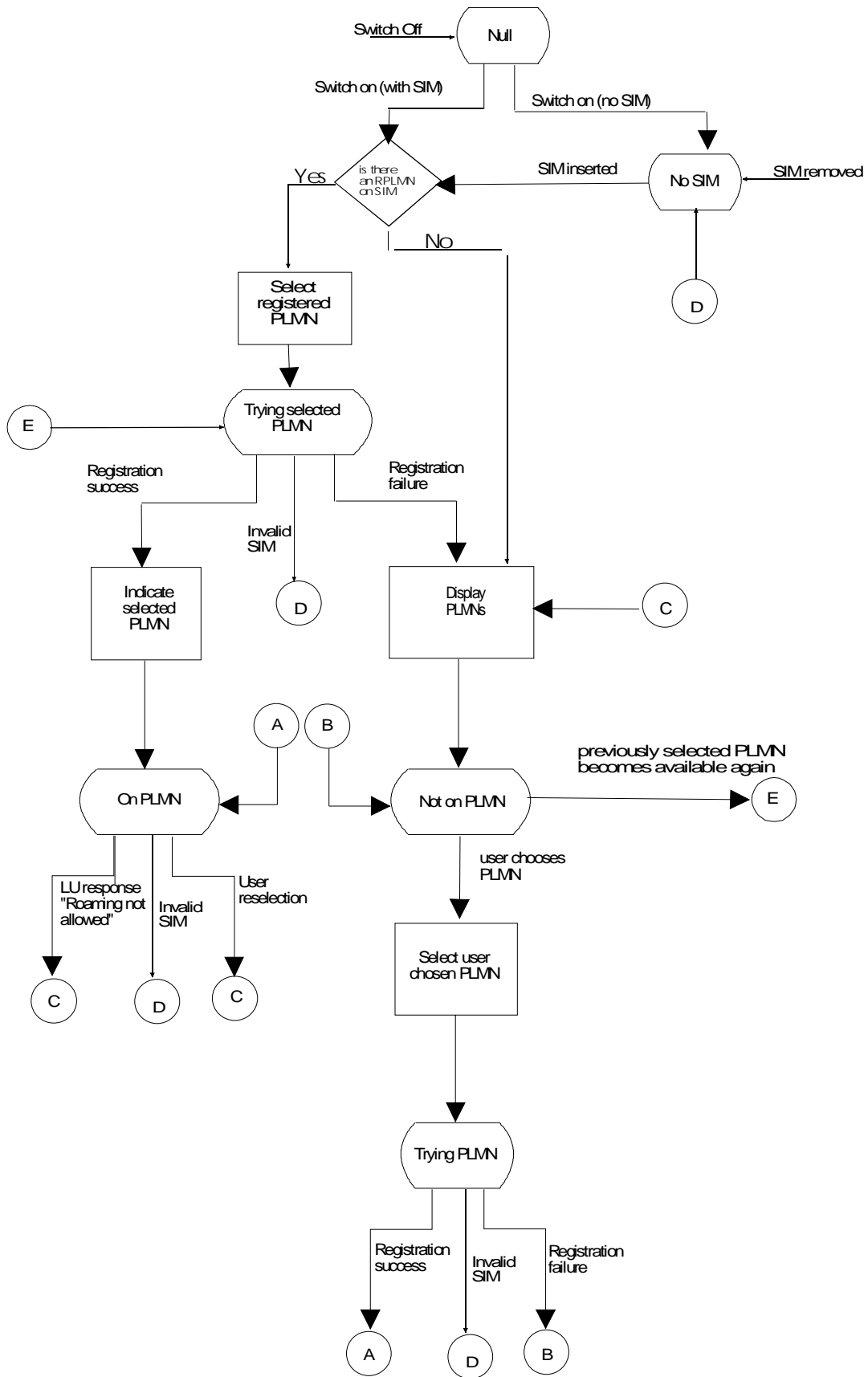
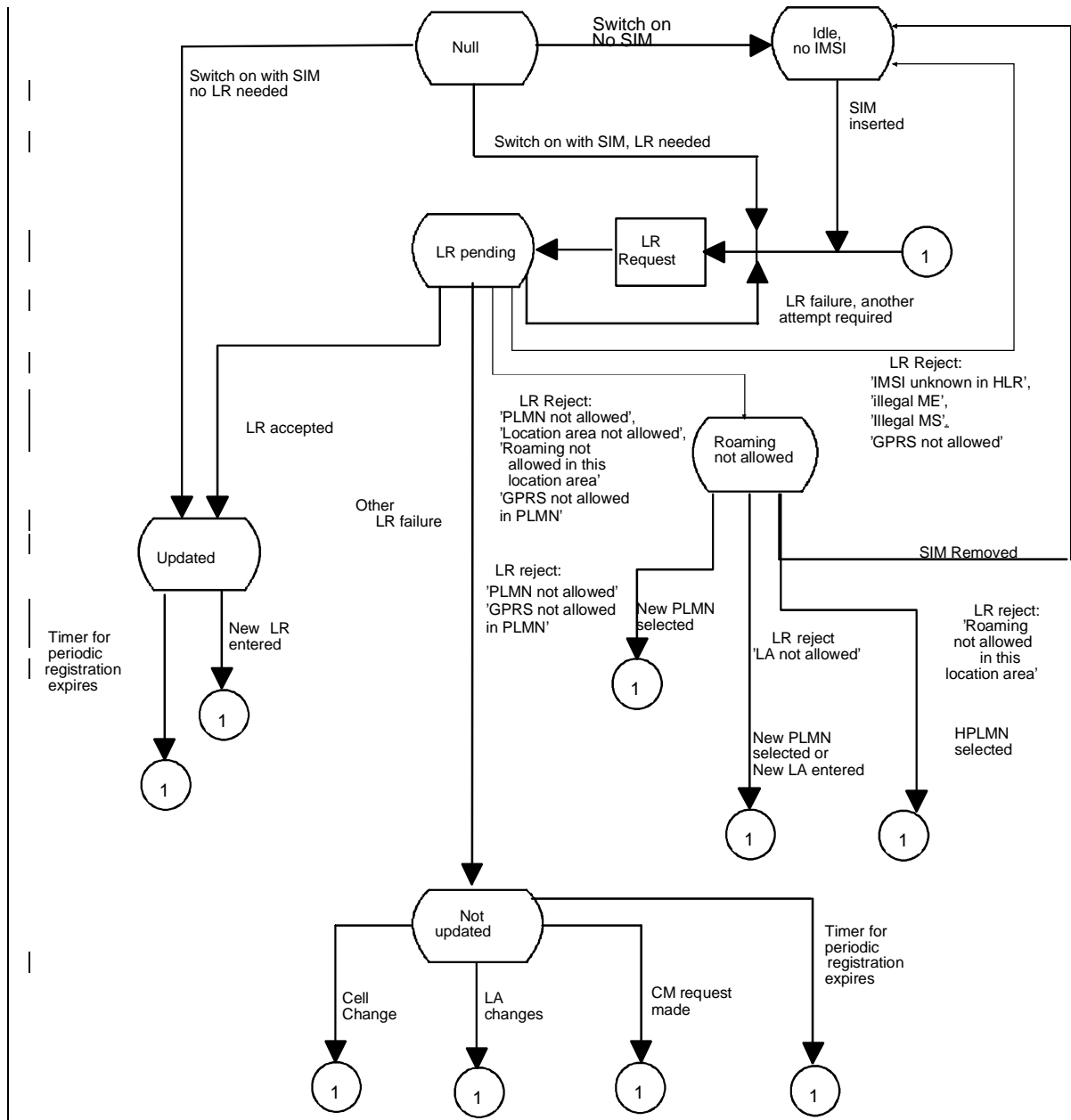

Figure 2b: PLMN Selection State diagram (manual mode)



NOTE 1: Whenever the MS goes to connected mode and then returns to idle mode again the MS selects appropriate state.

NOTE 2: A MS capable of GPRS and non-GPRS services has two Task State machines one for GPRS and one for non-GPRS operation.

Figure 3: Location Registration Task State diagram

Annex A (normative): HPLMN Matching Criteria

With the introduction of PCS1900 with the regulatory mandate to allocate 3-digit MNC codes, additional functionality is required to identify the HPLMN.

Assumptions

An MNC code shall consist of 2 or 3 decimal digits. In NA PCS1900, all SIMs shall store 3 digit MNCs. Any network using a 2 digit MNC code shall broadcast the hexadecimal code “F” in place of the 3rd digit. For PCS1900 for North America, regulations mandate that a 3-digit MNC shall be used; however during a transition period, a 2 digit MNC may be broadcast by the Network and, in this case, the 3rd digit of the SIM is stored as 0 (this is the 0 suffix rule).

With the exception of North America during the transition period:

- a) Within a single country (or area identified by a MCC) all networks shall broadcast a 2 digit MNC code, or all networks shall broadcast a 3 digit MNC code. A mixture of broadcast 2 and 3 digit MNC codes is not permitted within a single country (or area identified by a MCC).
- b) A network which broadcasts a 2 digit MNC code, will issue SIMs with a 2 digit MNC code in the IMSI on the SIM. A network which broadcasts a 3 digit MNC code, will issue SIMs with a 3 digit MNC code in the IMSI on the SIM.

Definitions and abbreviations

BCCH-MCC	The MCC part of the LAI read from System Information type 3 messages broadcast on the BCCH by the network.
BCCH-MNC	The MNC part of the LAI read from System Information type 3 messages broadcast on the BCCH by the network.
SIM-MCC	The MCC part of the IMSI read from the SIM.
SIM-MNC	The MNC part of the IMSI read from the SIM.

HPLMN Matching Criteria in mobiles which don't support PCS1900 for NA:

Figure A.1 illustrates the logic flow described below. The text below is normative. Figure A.1 is informative.

- (1) The MS shall compare using all 3 digits of the SIM-MCC with the BCCH-MCC. If the values do not match, then the HPLMN match fails.

NOTE: If the MCC codes match, then the number of digits used for the SIM-MNC must be the same as the number of digits used for the BCCH-MNC.

- (2) The MS shall read the 3rd digit of the BCCH-MNC. If the 3rd digit is Hex F, then proceed to step (4).
- (3) The MS shall compare using all 3 digits of the SIM-MNC with the BCCH-MNC. If the values match, then the HPLMN match succeeds, otherwise the HPLMN match fails.
- (4) The MS shall compare using just the 1st 2 digits the SIM-MNC with the BCCH-MNC. If the values match, then the HPLMN match succeeds, otherwise the HPLMN match fails.

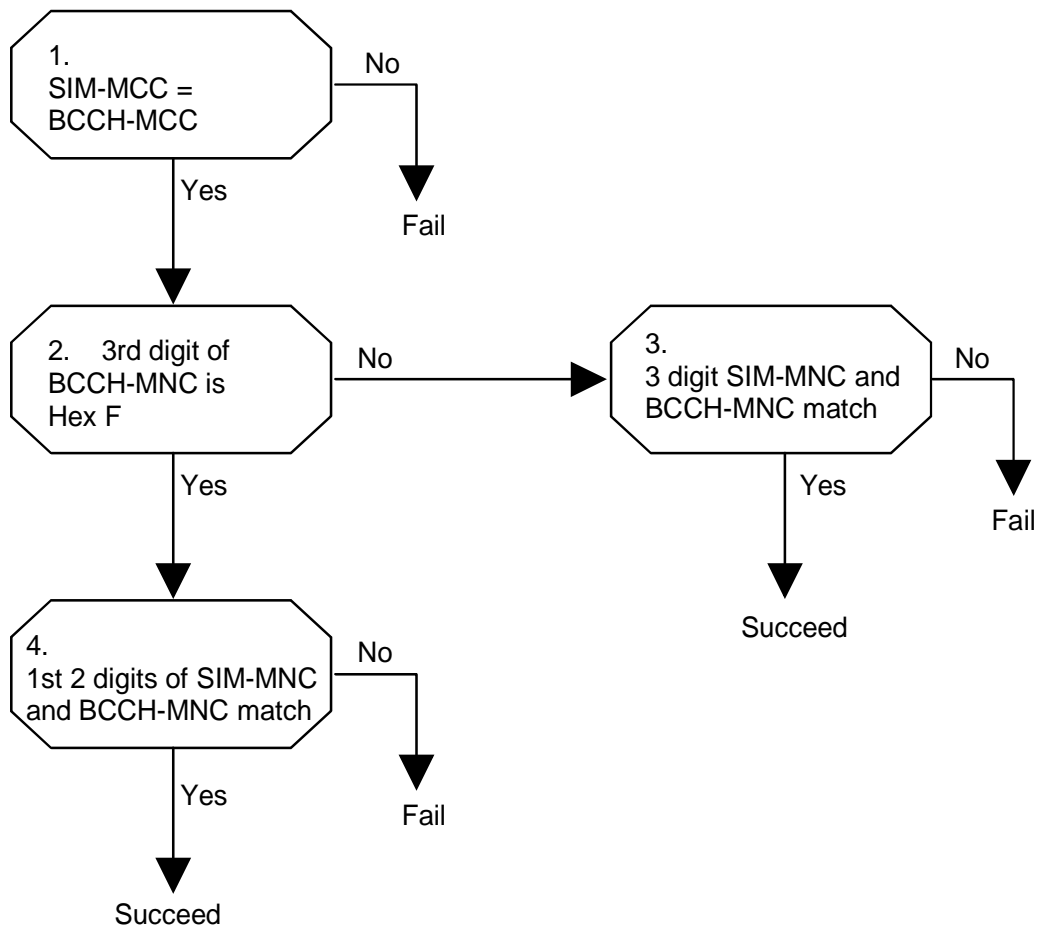

Figure A.1: HPLMN Matching Criteria Logic Flow for mobiles which support GSM and DCS1800 (informative)

HPLMN Matching Criteria for mobiles which support PCS1900 for NA:

Figure A.2 illustrates the logic flow described below. The text below is normative. Figure A.2 is informative.

- (1) The MS shall compare using all 3 digits the SIM-MCC with the BCCH-MCC. If the values do not match, then the HPLMN match fails.
- (2) The MS shall read the 3rd digit of the BCCH-MNC. If the 3rd digit is Hex F, then proceed to step (4).
- (3) The MS shall compare using all 3 digits the SIM-MNC with the BCCH-MNC. If the values match, then the HPLMN match succeeds, otherwise the HPLMN match fails.

NOTE: These rules (1) – (3) are the same as for mobiles which don't support PCS1900 for NA, except step (4) is different.

- (4) The MS shall determine if the BCCH-MCC lies in the range 310-316 (i.e., whether this network is a PCS1900 for NA network). If the BCCH-MCC lies outside the range 310-316, then proceed to step (6).
- (5) The MS shall compare the 3rd digit of the SIM-MNC with '0'. If the 3rd digit is not '0' then the HPLMN match fails.

NOTE: This is the '0' suffix rule.

- (6) The MS shall compare using just the 1st 2 digits of the SIM-MNC with the BCCH-MNC. If the values match, then the HPLMN match succeeds, otherwise the HPLMN match fails.

NOTE: When PCS1900 for NA switches over to broadcasting 3 digit MNCs in **all** networks, then the additional requirements for PCS1900 for NA can be deleted.

Guidance for Networks in PCS1900 for NA

There may be some problems in the transition period from broadcasting 2 MNC digits to broadcasting 3 MNC digits. Here are some guidelines to avoid these problems.

- (1) Existing network codes. Operators who currently use a 2 digit BCCH-MNC **xy** should use the new code **xy0**.
- (2) New operators allocated 3 digit MNC codes with the same 1st 2 digits as an existing operator shall not use a 3rd digit of 0.

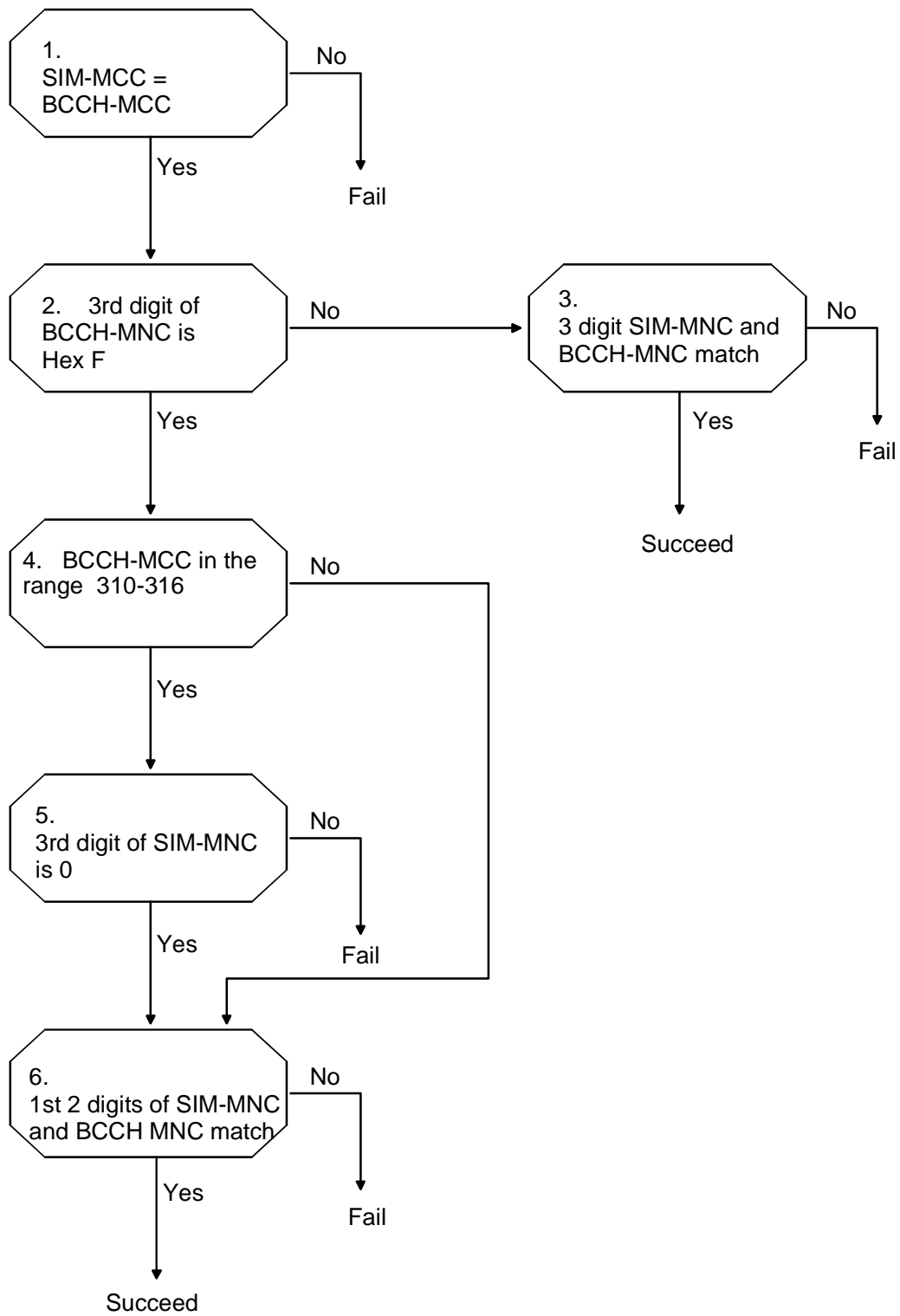

Figure A.2: HPLMN Matching Criteria Logic Flow for mobiles which support PCS1900 for NA (informative)

Annex B (normative): PLMN matching criteria to be of same country as VPLMN

While a MS is roaming on a VPLMN, PLMN of the same country as VPLMN is defined as:

- if the MCC of the current VPLMN is within the range 310 to 316, any PLMN in range 310 to 316 (networks in North America)
- otherwise, any PLMN with same MCC as the one of the current VPLMN itself.

Annex C (informative): Change history

TSG#	Tdoc	SPEC	VERS	CR	RE V	PHA SE	CA T	NEW _VER S	SUBJECT	comment
		03.22	8.2.0			R99			Split of 03.22/R99 to 03.22 and 23.122	
#6		23.122	0.0.0			R99		3.0.0		Was approved in the TSGN#6 plenary
#4	N1-99573	23.102	3.0.0	001		R99	F	3.1.0	PLMN selection for GPRS mobiles	Mirrored from CRA032r2 REMOVED in V3.1.1, where it is not approved by SMG2
#6	N1-99D13	23.122	3.0.0	002		R99	A	3.1.0	Correction of Figure A.2 in Annex A	Mirrored from CR006r1 for 23.022
#7	N1-000546	23.122	3.1.1	004	1	R99	D	3.2.0	UMTS references in 23.122	Correction of references
#8	N1-000796	23.122	3.2.0	003	5	R99	F	3.3.0	Modification of PLMN Selection Procedures to support UMTS+COMPACT Network Selection	WI: GSM / UMTS interworking Note As a result of two conflicting CRs N1-000796 is merged with the existing text in V.3.2.0 by the rapporteur
#9	NP-000443/ N1-001020	23.122	3.3.0	009	2	R99	F	3.4.0	Clarifications of the PLMN Selection procedures for UMTS and COMPACT.	
		23.122	3.4.0					3.4.1	Correction of text in version 3.4.0 (There was text to be deleted in section 4.4.3.2.1 bullet point 2)	23.Oct.2000 Implementation correction
		23.122	3.4.1					3.4.2	Correction of a systematic search for "TS" and replace it with "3GPP TS" has gone wrong as much more than the TSs for Technical Specifications have been changed also.	1 Nov..2000 Implementation correction
#10	NP-000674/ N1-001415	23.122	3.4.2	010	1	R99	F	3.5.0	Correction of terminology "In UMTS", "In GSM"	Cat F/ WI=TEI
#10	NP-000671/ N1-001236	23.122	3.4.2	012		R99	F	3.5.0	Restoration of figure A.1	Cat F/ WI=GSM - UMTS Interworking
#10	NP-000671/ N1-001237	23.122	3.4.2	013		R99	F	3.5.0	Alignment of figure 2a with PLMN selection for UMTS	Cat F/ WI=GSM - UMTS Interworking
#11	NP-010207/ N1-010472	23.122	3.5.0	014	3	R99	F	3.6.0	Clarification of the PLMN selection for UMTS regarding high quality signal	GSM - UMTS Interworking
#11	NP-010168/ N1-010224	23.122	3.5.0	016	1	R99	F	3.6.0	Roaming restrictions for GPRS service	GSM - UMTS Interworking
#11	NP-010205/ N1-010334	23.122	3.5.0	017		R99	F	3.6.0	remove use of GSM as default access technology in PLMN search	T.E.I
#11	NP-01089/ N1-010443	23.122	3.5.0	018		R99	F	3.6.0	Requirement of priority on High Quality Signal cell concerning Acceptable cell (for limited service as emergency call)	T.E.I
#11	NP-010186/ N1-010489	23.122	3.5.0	019	4	R99	F	3.6.0	Clarifications to PLMN search	T.E.I
#11	NP-010186/ N1-010490	23.122	3.5.0	020	1	R99	F	3.6.0	Clarifications to PLMN search	T.E.I
#11	NP-010180	23.122	3.5.0	022	1	R99	F	3.6.0	Equivalent handling of PLMNs with different PLMN codes	GSM - UMTS Interworking
#11			3.6.0					4.0.0	Upgraded to Release 4.	

CHANGE REQUEST

⌘ **23.122 CR 031** ⌘ rev **-** ⌘ Current version: **3.6.0** ⌘

For **HELP** on using this form, see bottom of this page or look at the pop-up text over the ⌘ symbols.

Proposed change affects: ⌘ (U)SIM ME/UE Radio Access Network Core Network

Title:	⌘ Removal of 'Requirement of priority on High Quality Signal cell concerning Acceptable cell (for limited service as emergency call)' from 23.122
Source:	⌘ France Telecom
Work item code:	⌘ TEI Date: ⌘ 12th May 2001
Category:	⌘ F Release: ⌘ R99
<p style="text-align: center;"><i>Use one of the following categories:</i></p> <p style="text-align: center;"> F (essential correction) A (corresponds to a correction in an earlier release) B (Addition of feature), C (Functional modification of feature) D (Editorial modification) </p> <p style="text-align: center;">Detailed explanations of the above categories can be found in 3GPP TR 21.900.</p>	
<p style="text-align: center;"><i>Use one of the following releases:</i></p> <p style="text-align: center;"> 2 (GSM Phase 2) R96 (Release 1996) R97 (Release 1997) R98 (Release 1998) R99 (Release 1999) REL-4 (Release 4) REL-5 (Release 5) </p>	

Reason for change:	⌘ Tdoc N1-010443 was presented and rejected during CN1 #16 meeting in February 2001, however it has been implemented within TS 23.122 v3.6.0. This CR aims at correcting this mistake of implementation.
Summary of change:	⌘ In § 3.5 and § 4.4.3.1.2, removal of the indication to take into account high signal quality as a criteria for acceptable cell (parts introduced by Tdoc N1-010443)
Consequences if not approved:	⌘ A wrong implementation of CR (a CR which was rejected) will not be corrected.

Clauses affected:	⌘
Other specs affected:	⌘ <input type="checkbox"/> Other core specifications ⌘ <input type="checkbox"/> Test specifications <input type="checkbox"/> O&M Specifications
Other comments:	⌘

How to create CRs using this form:

Comprehensive information and tips about how to create CRs can be found at: http://www.3gpp.org/3G_Specs/CRs.htm. Below is a brief summary:

- 1) Fill out the above form. The symbols above marked ⌘ contain pop-up help information about the field that they are closest to.
- 2) Obtain the latest version for the release of the specification to which the change is proposed. Use the MS Word "revision marks" feature (also known as "track changes") when making the changes. All 3GPP specifications can be downloaded from the 3GPP server under <ftp://www.3gpp.org/specs/> For the latest version, look for the directory name with the latest date e.g. 2000-09 contains the specifications resulting from the September 2000 TSG meetings.

- 3) With "track changes" disabled, paste the entire CR form (use CTRL-A to select it) into the specification just in front of the clause containing the first piece of changed text. Delete those parts of the specification which are not relevant to the change request.

3.5 No suitable cell (limited service state)

There are a number of situations in which the MS is unable to obtain normal service from a PLMN. These include:

- a) Failure to find a suitable cell of the selected PLMN;
- b) No SIM in the MS;
- c) A "PLMN not allowed" response to an LR;
- d) An "illegal MS", "illegal ME" or "IMSI unknown in HLR" response to an LR; (Any SIM in the ME is then considered "invalid".)
- e) A "GPRS not allowed" response to an LR of a GPRS MS attached to GPRS services only. (The cell selection state of GPRS MSs attached to GPRS and non-GPRS depends on the outcome of the location updating.)

(In automatic PLMN selection mode, events (a), (c) and (e) would normally cause a new PLMN selection, but even here, the situation may arise when no PLMNs are available and allowable for use).

Under any of these conditions, the MS attempts to camp on an acceptable cell, irrespective of its PLMN identity and giving priority to cell with received high quality signal, so that emergency calls can be made if necessary. When in the limited service state with a valid SIM, the MS shall search for available and allowable PLMNs in the manner described in subclause 4.4.3.1 and when indicated in the SIM also as described in subclause 4.4.3.4. No LR requests are made until a valid SIM is present and either a suitable cell is found or a manual network reselection is performed. In the limited service state the presence of the MS need not be known to the PLMN on whose cell it has camped.

~~NOTE: High quality signal is defined in the appropriate AS specification.~~

There are also other conditions under which only emergency calls may be made. These are shown in table 2 in clause 5.

-----NEXT CHANGE-----

4.4.3.1.2 Manual Network Selection Mode Procedure

The MS indicates whether there are any PLMNs, which are available using all supported access technologies. This includes "Forbidden PLMNs" and PLMNs which only offer services not supported by the MS. An MS which supports GSM COMPACT shall also indicate GSM COMPACT PLMNs (which use PBCCH).

If displayed, PLMNs meeting the criteria above are presented in the following order:

- i)- HPLMN;
- ii)- PLMNs contained in the " User Controlled PLMN Selector with Access Technology " data field in the SIM (in priority order);
- iii)- PLMNs contained in the "Operator Controlled PLMN Selector with Access Technology" data field in the SIM (in priority order);
- iv)- other PLMN/access technology combinations with received high quality signal in random order;
- v)- other PLMN/access technology combinations in order of decreasing signal quality.

In ii and iii, an MS using a SIM without access technology information storage (i.e. the "User Controlled PLMN Selector with Access Technology" and the "Operator Controlled PLMN Selector with Access Technology" data fields are not present) shall instead present the PLMNs contained in the "PLMN Selector" data field in the SIM (in priority order).

In v, requirement h) in section 4.4.3.1.1 applies.

In A/Gb mode or GSM COMPACT, if a PLMN does not support voice services then this shall be indicated to the user.

The user may select his desired PLMN and the MS then initiates registration on this PLMN using the access technology chosen by the user for that PLMN or using the highest priority available access technology for that PLMN, if the associated access technologies have a priority order. (This may take place at any time during the presentation of PLMNs). For such a registration, the MS shall ignore the contents of the forbidden LAI lists, "forbidden PLMNs for GPRS service" lists and forbidden PLMN lists.

NOTE: It is an MS implementation option whether to indicate access technologies to the user. If the MS does display access technologies, then the access technology used should be the access technology chosen by the user for that PLMN. If the MS does not display access technologies, then the access technology chosen for a particular PLMN should be the highest priority available access technology for that PLMN, if the associated access technologies have a priority order.

If the user does not select a PLMN, the selected PLMN shall be the one that was selected before the PLMN selection procedure started. If no such PLMN was selected or that PLMN is no longer available, then the MS shall attempt to camp on any acceptable ~~giving priority to cell with received high quality signal~~ cell and enter the limited service state.

NOTE: High quality signal is defined in the appropriate AS specification.

CHANGE REQUEST

⌘ **23.122 CR 032** ⌘ rev **-** ⌘ Current version: **4.0.0** ⌘

For **HELP** on using this form, see bottom of this page or look at the pop-up text over the ⌘ symbols.

Proposed change affects: ⌘ (U)SIM ME/UE Radio Access Network Core Network

Title:	⌘ Removal of 'Requirement of priority on High Quality Signal cell concerning Acceptable cell (for limited service as emergency call)' from 23.122
Source:	⌘ France Telecom
Work item code:	⌘ TEI Date: ⌘ 12th May 2001
Category:	⌘ A Release: ⌘ REL-4
<p style="text-align: center;"><i>Use one of the following categories:</i></p> <p style="text-align: center;"> F (essential correction) A (corresponds to a correction in an earlier release) B (Addition of feature), C (Functional modification of feature) D (Editorial modification) </p> <p style="text-align: center;">Detailed explanations of the above categories can be found in 3GPP TR 21.900.</p>	
<p style="text-align: center;"><i>Use one of the following releases:</i></p> <p style="text-align: center;"> 2 (GSM Phase 2) R96 (Release 1996) R97 (Release 1997) R98 (Release 1998) R99 (Release 1999) REL-4 (Release 4) REL-5 (Release 5) </p>	

Reason for change:	⌘ Tdoc N1-010443 was presented and rejected during CN1 #16 meeting in February 2001, however it has been implemented within TS 23.122 v4.0.0. This CR aims at correcting this mistake of implementation.
Summary of change:	⌘ In § 3.5 and § 4.4.3.1.2, removal of the indication to take into account high signal quality as a criteria for acceptable cell (parts introduced by Tdoc N1-010443)
Consequences if not approved:	⌘ A wrong implementation of CR (a CR which was rejected) will not be corrected.

Clauses affected:	⌘
Other specs affected:	⌘ <input type="checkbox"/> Other core specifications ⌘ <input type="checkbox"/> Test specifications <input type="checkbox"/> O&M Specifications
Other comments:	⌘

How to create CRs using this form:

Comprehensive information and tips about how to create CRs can be found at: http://www.3gpp.org/3G_Specs/CRs.htm. Below is a brief summary:

- 1) Fill out the above form. The symbols above marked ⌘ contain pop-up help information about the field that they are closest to.
- 2) Obtain the latest version for the release of the specification to which the change is proposed. Use the MS Word "revision marks" feature (also known as "track changes") when making the changes. All 3GPP specifications can be downloaded from the 3GPP server under <ftp://www.3gpp.org/specs/> For the latest version, look for the directory name with the latest date e.g. 2000-09 contains the specifications resulting from the September 2000 TSG meetings.

- 3) With "track changes" disabled, paste the entire CR form (use CTRL-A to select it) into the specification just in front of the clause containing the first piece of changed text. Delete those parts of the specification which are not relevant to the change request.

3.5 No suitable cell (limited service state)

There are a number of situations in which the MS is unable to obtain normal service from a PLMN. These include:

- a) Failure to find a suitable cell of the selected PLMN;
- b) No SIM in the MS;
- c) A "PLMN not allowed" response to an LR;
- d) An "illegal MS", "illegal ME" or "IMSI unknown in HLR" response to an LR; (Any SIM in the ME is then considered "invalid".)
- e) A "GPRS not allowed" response to an LR of a GPRS MS attached to GPRS services only. (The cell selection state of GPRS MSs attached to GPRS and non-GPRS depends on the outcome of the location updating.)

(In automatic PLMN selection mode, events (a), (c) and (e) would normally cause a new PLMN selection, but even here, the situation may arise when no PLMNs are available and allowable for use).

Under any of these conditions, the MS attempts to camp on an acceptable cell, irrespective of its PLMN identity and giving priority to cell with received high quality signal, so that emergency calls can be made if necessary. When in the limited service state with a valid SIM, the MS shall search for available and allowable PLMNs in the manner described in subclause 4.4.3.1 and when indicated in the SIM also as described in subclause 4.4.3.4. No LR requests are made until a valid SIM is present and either a suitable cell is found or a manual network reselection is performed. In the limited service state the presence of the MS need not be known to the PLMN on whose cell it has camped.

~~NOTE: High quality signal is defined in the appropriate AS specification.~~

There are also other conditions under which only emergency calls may be made. These are shown in table 2 in clause 5.

-----NEXT CHANGE-----

4.4.3.1.2 Manual Network Selection Mode Procedure

The MS indicates whether there are any PLMNs, which are available using all supported access technologies. This includes "Forbidden PLMNs" and PLMNs which only offer services not supported by the MS. An MS which supports GSM COMPACT shall also indicate GSM COMPACT PLMNs (which use PBCCH).

If displayed, PLMNs meeting the criteria above are presented in the following order:

- i)- HPLMN;
- ii)- PLMNs contained in the " User Controlled PLMN Selector with Access Technology " data field in the SIM (in priority order);
- iii)- PLMNs contained in the "Operator Controlled PLMN Selector with Access Technology" data field in the SIM (in priority order);
- iv)- other PLMN/access technology combinations with received high quality signal in random order;
- v)- other PLMN/access technology combinations in order of decreasing signal quality.

In ii and iii, an MS using a SIM without access technology information storage (i.e. the "User Controlled PLMN Selector with Access Technology" and the "Operator Controlled PLMN Selector with Access Technology" data fields are not present) shall instead present the PLMNs contained in the "PLMN Selector" data field in the SIM (in priority order).

In v, requirement h) in section 4.4.3.1.1 applies.

In A/Gb mode or GSM COMPACT, if a PLMN does not support voice services then this shall be indicated to the user.

The user may select his desired PLMN and the MS then initiates registration on this PLMN using the access technology chosen by the user for that PLMN or using the highest priority available access technology for that PLMN, if the

associated access technologies have a priority order. (This may take place at any time during the presentation of PLMNs). For such a registration, the MS shall ignore the contents of the forbidden LAI lists, "forbidden PLMNs for GPRS service" lists and forbidden PLMN lists.

NOTE: It is an MS implementation option whether to indicate access technologies to the user. If the MS does display access technologies, then the access technology used should be the access technology chosen by the user for that PLMN. If the MS does not display access technologies, then the access technology chosen for a particular PLMN should be the highest priority available access technology for that PLMN, if the associated access technologies have a priority order.

If the user does not select a PLMN, the selected PLMN shall be the one that was selected before the PLMN selection procedure started. If no such PLMN was selected or that PLMN is no longer available, then the MS shall attempt to camp on any acceptable ~~giving priority to cell with received high quality signal~~ cell and enter the limited service state.

NOTE: High quality signal is defined in the appropriate AS specification.

CHANGE REQUEST

⌘ **23.122 CR 033** ⌘ rev **-** ⌘ Current version: **3.6.0** ⌘

For **HELP** on using this form, see bottom of this page or look at the pop-up text over the ⌘ symbols.

Proposed change affects: ⌘ (U)SIM ME/UE Radio Access Network Core Network

Title:	⌘ Alignment with stage 1 specification on PLMN background search		
Source:	⌘ France Telecom		
Work item code:	⌘ TEI	Date:	⌘ 12 th May
Category:	⌘ F	Release:	⌘ R99
	<i>Use <u>one</u> of the following categories:</i> F (essential correction) A (corresponds to a correction in an earlier release) B (Addition of feature), C (Functional modification of feature) D (Editorial modification) Detailed explanations of the above categories can be found in 3GPP TR 21.900.		<i>Use <u>one</u> of the following releases:</i> 2 (GSM Phase 2) R96 (Release 1996) R97 (Release 1997) R98 (Release 1998) R99 (Release 1999) REL-4 (Release 4) REL-5 (Release 5)

Reason for change:	⌘ Alignment of stage 2 specification on SA1's stage 1 specification. This was discussed and agreed during the ad-hoc meeting between SA1 and CN1 held on May 8 th .
Summary of change:	⌘ While searching for higher prioritized PLMNs, only the priority of 'equivalent PLMNs' of the same country as the current Registered PLMN shall be taken into account
Consequences if not approved:	⌘ Misalignment between stage 1 and stage 2 specifications

Clauses affected:	⌘ 4.4.3.3		
Other specs affected:	⌘ <input type="checkbox"/> Other core specifications	⌘ <input type="checkbox"/>	
	<input type="checkbox"/> Test specifications		
	<input type="checkbox"/> O&M Specifications		
Other comments:	⌘		

How to create CRs using this form:

Comprehensive information and tips about how to create CRs can be found at: http://www.3gpp.org/3G_Specs/CRs.htm. Below is a brief summary:

- 1) Fill out the above form. The symbols above marked ⌘ contain pop-up help information about the field that they are closest to.
- 2) Obtain the latest version for the release of the specification to which the change is proposed. Use the MS Word "revision marks" feature (also known as "track changes") when making the changes. All 3GPP specifications can be downloaded from the 3GPP server under <ftp://www.3gpp.org/specs/> For the latest version, look for the directory name with the latest date e.g. 2000-09 contains the specifications resulting from the September 2000 TSG meetings.

- 3) With "track changes" disabled, paste the entire CR form (use CTRL-A to select it) into the specification just in front of the clause containing the first piece of changed text. Delete those parts of the specification which are not relevant to the change request.

4.4.3.3 In VPLMN

If the MS is in a VPLMN and the HPLMN is not in the stored list of equivalent PLMNs, the MS shall periodically attempt to obtain service on its HPLMN or higher priority PLMN listed in "user controlled PLMN selector" or "operator controlled PLMN selector" by scanning in accordance with the requirements that are applicable to i), ii) and iii) as defined in the Automatic Network Selection Mode in clause 4.4.3.1.1. In the case that the mobile has a stored "Equivalent PLMNs" list the mobile shall only select a PLMN if it is of a higher priority than ~~any of those of the same country as the current serving PLMN~~ which are stored in the "Equivalent PLMNs" list. For this purpose, a value T minutes may be stored in the SIM, T is either in the range 6 minutes to 8 hours in 6 minute steps or it indicates that no periodic attempts shall be made. If no value is stored in the SIM, a default value of 60 minutes is used.

The attempts to access the HPLMN or higher priority PLMN shall be as specified below:

- a) The periodic attempts shall only be performed in automatic mode when the MS is roaming;
- b) After switch on, a period of at least 2 minutes and at most T minutes shall elapse before the first attempt is made;
- c) The MS shall make an attempt if the MS is on the VPLMN at time T after the last attempt;
- d) Periodic attempts shall only be performed by the MS while in idle mode;
- e) If the HPLMN or higher priority PLMN is not found, the MS shall remain on the VPLMN.
- f) ~~In steps i), ii) and iii) the MS shall limit its attempts to access higher priority PLMNs to PLMNs of the same country as the current serving VPLMN.~~
- g) Only the priority levels of Equivalent PLMNs of the same country as the current serving VPLMN shall be taken into account to compare with the priority level of a selected PLMN.

CHANGE REQUEST

⌘ **23.122 CR 034** ⌘ rev **-** ⌘ Current version: **4.0.0** ⌘

For **HELP** on using this form, see bottom of this page or look at the pop-up text over the ⌘ symbols.

Proposed change affects: ⌘ (U)SIM ME/UE Radio Access Network Core Network

Title:	⌘ Alignment with stage 1 specification on PLMN background search		
Source:	⌘ France Telecom		
Work item code:	⌘ TEI	Date:	⌘ 12 th May
Category:	⌘ A	Release:	⌘ REL-4
	Use <u>one</u> of the following categories: F (essential correction) A (corresponds to a correction in an earlier release) B (Addition of feature), C (Functional modification of feature) D (Editorial modification) Detailed explanations of the above categories can be found in 3GPP TR 21.900.		Use <u>one</u> of the following releases: 2 (GSM Phase 2) R96 (Release 1996) R97 (Release 1997) R98 (Release 1998) R99 (Release 1999) REL-4 (Release 4) REL-5 (Release 5)

Reason for change:	⌘ Alignment of stage 2 specification on SA1's stage 1 specification. This was discussed and agreed during the ad-hoc meeting between SA1 and CN1 held on May 8 th .
Summary of change:	⌘ While searching for higher prioritized PLMNs, only the priority of 'equivalent PLMNs' of the same country as the current Registered PLMN shall be taken into account
Consequences if not approved:	⌘ Misalignment between stage 1 and stage 2 specifications

Clauses affected:	⌘ 4.4.3.3		
Other specs affected:	⌘ <input type="checkbox"/> Other core specifications <input type="checkbox"/> Test specifications <input type="checkbox"/> O&M Specifications	⌘	
Other comments:	⌘		

How to create CRs using this form:

Comprehensive information and tips about how to create CRs can be found at: http://www.3gpp.org/3G_Specs/CRs.htm. Below is a brief summary:

- 1) Fill out the above form. The symbols above marked ⌘ contain pop-up help information about the field that they are closest to.
- 2) Obtain the latest version for the release of the specification to which the change is proposed. Use the MS Word "revision marks" feature (also known as "track changes") when making the changes. All 3GPP specifications can be downloaded from the 3GPP server under <ftp://www.3gpp.org/specs/> For the latest version, look for the directory name with the latest date e.g. 2000-09 contains the specifications resulting from the September 2000 TSG meetings.
- 3) With "track changes" disabled, paste the entire CR form (use CTRL-A to select it) into the specification just in front of the clause containing the first piece of changed text. Delete those parts of the specification which are not relevant to the change request.

4.4.3.3 In VPLMN

If the MS is in a VPLMN and the HPLMN is not in the stored list of equivalent PLMNs, the MS shall periodically attempt to obtain service on its HPLMN or higher priority PLMN listed in "user controlled PLMN selector" or "operator controlled PLMN selector" by scanning in accordance with the requirements that are applicable to i), ii) and iii) as defined in the Automatic Network Selection Mode in clause 4.4.3.1.1. In the case that the mobile has a stored "Equivalent PLMNs" list the mobile shall only select a PLMN if it is of a higher priority than ~~any of those~~ of the same country as the current serving PLMN which are stored in the "Equivalent PLMNs" list. For this purpose, a value T minutes may be stored in the SIM, T is either in the range 6 minutes to 8 hours in 6 minute steps or it indicates that no periodic attempts shall be made. If no value is stored in the SIM, a default value of 60 minutes is used.

The attempts to access the HPLMN or higher priority PLMN shall be as specified below:

- a) The periodic attempts shall only be performed in automatic mode when the MS is roaming;
- b) After switch on, a period of at least 2 minutes and at most T minutes shall elapse before the first attempt is made;
- c) The MS shall make an attempt if the MS is on the VPLMN at time T after the last attempt;
- d) Periodic attempts shall only be performed by the MS while in idle mode;
- e) If the HPLMN or higher priority PLMN is not found, the MS shall remain on the VPLMN.
- f) ~~ƒ~~ In steps i), ii) and iii) the MS shall limit its attempts to access higher priority PLMNs to PLMNs of the same country as the current serving VPLMN.
- g) Only the priority levels of Equivalent PLMNs of the same country as the current serving VPLMN shall be taken into account to compare with the priority level of a selected PLMN.