

Meeting #6, Nice, France
13th - 15th December 1999

Title: 3GPP TS 25.305: Stage 2 Functional Specification of LCS in UTRAN
Source: Nokia
Agenda Item: 5.7.1
Document for: Information

TSG-RAN Working Group 2 (Radio L2 and Radio L3)
Sophia Antipolis, 29 November – 3 December 1999

TSGR2#9(99)H74J45

Agenda Item: LCS

Source: ~~Editor~~ WG2

Title: 3GPP TS 25.305: Stage 2 Functional Specification of Location Services in UTRAN

Document for: Approval

This contribution proposes changes to TS 25.305 v1.4.0.

Contributions proposed to the Cheju meeting were discussed at the LCS Ad-Hoc meeting held November 25-26, 1999 in Sophia Antipolis and are included. -Also included are further contributions presented and discussed at the ad-hoc meeting. These changes were agreed at the meeting. This version includes the agreed material on Time Aligned IPDL OTDOA which was inadvertently left out by the editor in the previous issue of this tdoc.

This is proposed to WG2 to be approved as v.12.50.0.

3G TS 25.305 V2.0.0 (1999-12)

Technical Specification

**3rd Generation Partnership Project (3GPP);
Technical Specification Group Radio Access Network
Stage 2 Functional Specification of Location Services in
UTRAN
(3G TS 25.305 version 1.5.0)**



Reference

DTS/TSGS-01221210 (25305-140.PDF)

Keywords

Location Service, LCS, Positioning,
Digital cellular telecommunications system,
Universal Mobile Telecommunications System
LCS,
(UMTS), UTRA, UTRAN, IMT-2000,
Functional description stage 2

3GPP

Postal address

Office address

Internet

secretariat@3gpp.org
Individual copies of this deliverable
can be downloaded from
<http://www.3gpp.org>

Copyright Notification

No part may be reproduced except as authorized by written permission.
The copyright and the foregoing restriction extend to reproduction in all media.

© 1999, 3GPP Organizational Partners (ARIB, CWTS, ETSI, T1, TTA, TTC).
All rights reserved.

Contents

Foreword.....	6
1 Scope.....	7
2 References.....	7
2.1 Normative references	7
2.2 Informative references	8
3 Definitions and Abbreviations.....	8
3.1 Definitions	8
3.2 Abbreviations.....	8
4 Main concepts.....	8
4.1 Assumptions.....	9
4.2 Location Services Categories.....	9
4.3 Locating Methods	10
4.4 Standard LCS Methods.....	10
4.4.1 Cell ID Based Method.....	11
4.4.2 OTDOA-IPDL Method with network configurable idle periods.....	11
4.4.2.1 Use of Idle Periods	13
4.4.2.1.1 Operation and specification of idle periods	13
4.4.2.2 Accuracy.....	17
4.4.2.3 Relative Time Difference (RTD).....	17
4.4.2.4 Time of Day (ToD).....	18
4.4.2.5 Base Station Synchronisation	18
4.4.3 Network Assisted GPS Methods	18
4.4.3.1 Timing calibration	20
4.4.3.2 Timing assistance.....	20
4.4.3.3 Data assistance.....	20
4.4.3.4 UE search.....	21
4.4.3.5 Location determination	21
4.4.3.5.1 UE-based method.....	21
4.4.3.5.2 UE-assisted method	21
4.5 Other methods.....	22
4.5.1 Angle of Arrival (AOA).....	22
4.5.2 Observed Time of Arrival (OTOA).....	22
4.5.3 Reference Node-Based Positioning (OTDOA-RNBP).....	22
4.5.4 OTDOA – Positioning Elements (OTDOA-PE).....	22
5 UTRAN LCS Architecture	24
5.1 LCS Operations.....	24
5.2 High-Level Functions	26
5.2.1 Co-ordination, Measurement and Calculation Functions	26
5.3 UTRAN LCS Functional Entities	26
5.3.1 Internal Client Group	27
5.3.1.1 Internal UTRAN Location Client Function (U-LCF)	27
5.3.2 UTRAN System Handling group	28
5.3.2.1 UTRAN Location System Control Function (U-LSCF)	28
5.3.2.2 UTRAN Location System Operations Function (U-LSOF).....	28
5.3.3 Positioning group	29
5.3.3.1 UTRAN Positioning Radio Co-ordination Function (U-PRCF)	29
5.3.3.2 UTRAN Positioning Calculation Function (U-PCF)	29
5.3.3.3 UTRAN Positioning Signal Measurement Function (U-PSMF).....	29
5.3.3.4 UTRAN Positioning Radio Resource Management (U-PRRM).....	29
5.4 Assignment of LCS Functional Entities to UTRAN Elements.....	30
5.5 Functional Description of UTRAN LCS Network elements.....	30
5.5.1 Radio Network Controller (RNC).....	30
5.5.1.1 Serving RNC.....	30
5.5.1.2 Other RNC.....	31

5.5.2	Node-B	31
5.5.3	Location measurement unit (LMU)	31
5.5.4	UE	31
6	Interfaces and Information Flow	32
6.1	Generic information flow for LCS in UMTS	32
6.2	Interfaces	33
6.2.1	Iu Interface	33
6.2.2	Iur Interface	34
6.2.2.1	Signalling between RNCs	35
6.2.3	Iub Interface	35
6.2.3.1	Signalling between RNC and Node B (LMU)	35
6.2.4	Uu Interface	35
6.2.4.1	Signalling between RNC and Target UE	35
6.2.4.1.1	OTDOA-IPDL	35
6.2.4.1.2	GPS Assisted	36
6.2.4.1.3	Round Trip Time (RTT)	38
7	General UMTS location procedures	38
7.1	State description for RNC (for LCS)	39
7.2	State description for LMU (stand-alone)	39
7.3	State description for Node-B (for LCS)	39
7.4	General network positioning procedures	39
7.5	Exception procedures	39
8	Positioning method management (signalling flows)	39
8.1	OTDOA positioning	39
8.1.1	Idle Period DownLink timing procedures (IPDL)	39
8.1.2	Reference Node-Based positioning	39
8.1.3	Round Trip Time Positioning	39
8.2	Network assisted GPS positioning	39
9	Position calculation functionality	39
10	Information storage	39
11	Operational aspects	39
	Annex A (Informative): Definitions and Terms	40
	History	42

Foreword

This Technical Specification has been produced by the 3GPP.

The contents of the present document are subject to continuing work within the TSG and may change following formal TSG approval. Should the TSG modify the contents of this TS, it will be re-released by the TSG with an identifying change of release date and an increase in version number as follows:

Version x.y.z

where:

- x the first digit:
 - 1 presented to TSG for information;
 - 2 presented to TSG for approval;
 - 3 Indicates TSG approved document under change control.
- y the second digit is incremented for all changes of substance, i.e. technical enhancements, corrections, updates, etc.
- z the third digit is incremented when editorial only changes have been incorporated in the specification.

1 Scope

This document specifies the stage 2 of the LoCation Services (LCS) feature in UTRAN, which provides the mechanisms to support mobile location services for operators, subscribers and third party service providers.

The purpose of this stage2 specification is to define the UTRAN LCS architecture, functional entities and operations to support location methods. This description is confined to the aspects of LCS within the UTRAN and does not define nor describe the LCS entities or operations within the Core Network.

Location Services may be considered as a network provided enabling technology consisting of standardised service capabilities, which enable the provision of location applications. The application(s) may be service provider specific. The description of the numerous and varied possible location applications which are enabled by this technology are outside the scope of this specification. However, clarifying examples of how the functionality being described may be used to provide specific location services may be included.

This stage 2 specification covers the UTRAN LCS functional model and entities, the positioning methods, state descriptions, and message flows.

2 References

The following documents contain provisions which, through reference in this text, constitute provisions of the present document.

- References are either specific (identified by date of publication, edition number, version number, etc.) or non-specific.
- For a specific reference, subsequent revisions do not apply.
- For a non-specific reference, the latest version applies.

2.1 Normative references

- [1] 3G TS 23.xxx: "3rd Generation Partnership Project (3GPP); Technical Specification Group (TSG) Services and System Aspects; "Functional stage 2 description of location services in UMTS"
- [2] GSM 01.04 (ETR 350): "Digital cellular telecommunication system (Phase 2+); Abbreviations and acronyms"
- [3] Technical Specification Group Services and System Aspects Service aspects; Terminology and Vocabulary within TSG-S1: Report and Recommendations, 28.7.99
- [4] GSM 02.71: "Digital cellular telecommunications system (Phase 2+); Location Services (LCS); Service description, Stage 1"
- [5] GSM 03.71: "Digital cellular telecommunications system (Phase 2+); Location Services (LCS); (Functional description) - Stage 2"
- [6] GSM 03.32: "Universal Geographical Area Description"
- [7] 3G TS 22.100: "3rd Generation Partnership Project; Technical Specification Group Services and System Aspects, UMTS phase 1 Release 99"
- [8] 3G TS 22.101: "3rd Generation Partnership Project; Technical Specification Group Services and System Aspects; Service principles"
- [9] 3G TS 22.105: "3rd Generation Partnership Project; Technical Specification Group Services and System Aspects; Services and Service Capabilities"
- [10] 3G TS 22.115: "3rd Generation Partnership Project; Technical Specification Group Services and System Aspects; Charging and Billing"

- [11] 3G TS 22.121: "3rd Generation Partnership Project; Technical Specification Group Services and System Aspects Service aspects; The Virtual Home Environment"
- [12] 3G TS 23.110: "3rd Generation Partnership Project; Technical Specification Group Services and System Aspects UMTS Access Stratum; Services and Functions"
- [13] 3G TS 25.413: "UTRAN Iu interface RANAP signalling "
- [14] 3G TS 25.423: "UTRAN Iur interface RNSAP signalling "
- [15] 3G TS 25.433: " UTRAN Iub interface NBAP signalling "

2.2 Informative references

- [13] Third generation (3G) mobile communication system; Technical study report on the location services and technologies, ARIB ST9 December 1998.
- [14] The North American Interest Group of the GSM MoU ASSOCIATION: Location Based Services, Service Requirements Document of the Services Working Group

3 Definitions and Abbreviations

3.1 Definitions

For the purposes of the present document, the following terms and definitions apply:

Some definitions are included in Annex A

Further UMTS related definitions are given in 3G TS 22.101.

3.2 Abbreviations

For the purposes of the present document, the following abbreviations apply:

...
...

Further GSM related abbreviations are given in GSM 01.04.

Further UMTS related abbreviations are given in UMTS TS 22.101.

4 Main concepts

A general description of location services and the service requirements is given in the specification 3G TS 22.071 [4].

By ~~making use of the UTRAN~~measuring radio signals the capability to determine the (geographic) location of the user equipment (UE) ~~mobile station~~ shall be provided. The location information may be requested by and reported to a client (application) associated with the UE, or by a client within or attached to the Core Network. The location information may also be utilised internally by UTRAN, for example, for location assisted handover or to support other features such as home location billing. The position information shall be reported in standard formats, such as those for cell based or geographical co-ordinates, together with the time-of-day and the estimated errors (uncertainty) of the location of the UE.

It shall be possible for the majority of the UE (active or idle) within a network to use the feature without compromising the radio transmission or signalling capabilities of the UTRAN.

The uncertainty of the location measurement shall be network design (implementation) dependent at the choice of the network operator. The uncertainty may vary between networks as well as from one area within a network to another. The uncertainty may be hundreds of metres in some areas and only a few metres in others. In the event that the location measurement is also a UE assisted process, the uncertainty may also depend on the capabilities of the UE. In some jurisdictions, there is a regulatory requirement for location service accuracy that is part of an emergency service. Further details of the accuracy requirements can be found in [4].

The uncertainty of the location information is dependent on the method used, the location of the UE within the coverage area and the idle or active state of the UE. ~~techniques available for use at a location may also affect the uncertainty dependent on the state of the UE (idle or communications state).~~ Several design options of the UTRAN system (e.g. size of cell, adaptive antenna technique, path loss estimation, timing accuracy, base station surveys) shall allow the network operator to choose a suitable and cost effective location service feature for their market.

There are many different possible uses for the location information. The positioning feature may be used internally by the UTRAN network (or attached networks), by value-added network services, by the UE itself or through the network, and by “third party” services. The positioning feature may also be used by an emergency service (which may be mandated or “value-added”), but the position service is not exclusively for emergencies.

The UTRAN is a new radio system design without a pre-existing deployment of UE operating according to the air interface. This freedom from legacy equipment enables the positioning service feature design to make use of appropriate techniques to provide the most accurate results. The technique must also be a cost-effective total solution, must allow evolution to meet evolving service requirements and be able to take advantage of advances in technology over the lifetime of UTRAN deployments.

4.1 Assumptions

As a basis for the ~~development work on~~ operation of LCS in UTRAN the following assumptions apply:

- In case an MS supports LCS, it shall support at least one of the ~~selected~~ locating method(s) specified in UTRAN Stage-2 ~~this specification.~~
- The provision of the location service in UTRAN is optional through support of the specified method(s) in Node-B and the associated RNC.
- ~~The provision of location services is optional in 3G-MSC and 3G-SGSN.~~
- LCS is applicable to any target UE whether or not the UE supports LCS, but with restrictions on choice of positioning method or notification of a location request to the UE user when LCS or individual positioning methods, respectively, are not supported by the UE.
- RNC contains SMLC functionality and LCS information is transported between RNCs via the Iur interface.
- LCS shall be applicable for both circuit switched and packet switched services.
- The location information may be used for internal system operations to improve system performance
- There are different types of LMU ~~are FFS~~, e.g. the need for standalone LMU and/or LMU integrated in Node B.
- The positioning process shall include the option to accommodate several techniques of measurement and processing to ensure evolution to follow changing service requirements and to take advantage of advancing technology.
- ~~Iur shall be used for LCS signalling whenever it is available, even in the case when the RNCs connected to different 3G-MSCs or 3G-SGSN.~~

4.2 Location Services Categories

Generally there are four categories of usage of the location service. ~~These are the Commercial LCS, the Internal LCS, the Emergency LCS and the Lawful Intercept LCS. The definition of these services and their categories is outside the scope of this document.;~~

- The **Commercial LCS** (or **Value Added Services**) will typically be associated with an application that provides a value added service through knowledge of the UE location to the subscriber of the service. This may be, for example, a directory of restaurants in the local area of the UE together with directions for reaching them from the current UE location.
- The **Internal LCS** will typically be developed to make use of the location information of the UE for UTRAN internal operations. This may include, for example, location assisted handover and traffic and coverage measurement. This may also include support certain O&M related tasks, supplementary services, IN related services and GSM bearer services and teleservices.
- The **Emergency LCS** will typically be part of a service provided to assist subscribers who place emergency calls. In this service, the location of the UE caller is provided to the emergency service provider to assist them in their response. This service may be mandatory in some jurisdictions. In the United States, for example, this service is mandated for all mobile voice subscribers.
- ~~—The **Lawful Intercept LCS** will use the location information to support various legally required or sanctioned services.~~

These location services categories are further defined in [1] and [4].

4.3 Locating Methods

The LCS feature utilises one or more location methods in order to determine the location of User Equipment (UE) or Mobile Stations. Locating the position of a UE involves two main steps:

- signal measurements and
- location estimate computation based on the measurements.

The signal measurements may be made by the UE, the Node B or a dedicated location measuring unit (LMU). The basic signals measured are typically the UTRA radio transmissions, but some optional methods may make use of other transmissions such as general radio navigation signals. The location estimate computation may be made in the UE or by a calculation function located in the UTRAN.

~~A number of location methods are possible for LCS. These include :~~

- ~~—Cell identity [the representation of “Cell ID” in Iu signalling is FFS since the radio aspects should be hidden from the core network]~~
- ~~—Observed Time Difference of Arrival (OTDOA), with optional Idle Period DownLink (IPDL)~~
- ~~—Round Trip Time (RTT),~~
- ~~—General navigation system assisted (e.g. GPS),~~
- ~~—Reference Node Based Positioning~~
- ~~—Angle of arrival (AOA),~~
- ~~—Observed Time of Arrival (OTOA).~~

4.4 Standard LCS Methods

This specification, for Release '99, specifies the following LCS positioning methods:

- Cell coverage based positioning method;
- OTDOA method with network configurable idle periods (the idle period configurability is to be specified in the specification); and
- network assisted GPS methods;

NOTE: GPS based solutions are being standardised in T1P1; it is intended that the UTRAN navigational assisted solution will be synergistic with the work in T1P1².

4.4.1 Cell ID Based Method

In the cell ID based (i.e. cell coverage) positioning method the position of an UE is estimated with the knowledge of its serving node-B. The information about the serving node-B and cell may be obtained by paging, locating area update, cell update, URA update, or routing area update.

The cell coverage based location information can be indicated as the Cell Identity of the used cell, the Service area identity or as the geographical coordinates of a location related to the serving cell. The location information shall include a QoS estimate (e.g. regarding achieved accuracy).

When geographical coordinates are used as the location information, the estimated position of the UE can be a fixed geographical location within the serving cell (e.g. location of the serving node-B), the geographical centre of the serving cell coverage area, or some other fixed location within the cell coverage area. The geographical location can also be obtained by combining information on the cell specific fixed geographical location with some other available information, such as the signal Round Trip Time (RTT). [text to be added here on cell ID coverage based method]

4.4.2 OTDOA-IPDL Method with network configurable idle periods

NOTE: ~~the following text is provided as a basis~~

This method involves measurements made by the UE and LMU of the UTRA pilot signal (CPICH) radio transmissions. These measures are then sent to a Position Calculation Function (PCF) in the Serving RNC where the location of the UE is calculated.

Optionally, a PCF may be included in the UE, in which case the calculation of the location from the measurements may alternatively be performed in the UE.

The primary standard measurements are of the observed time difference of arrival (OTDOA) of downlink CPICH signals received at the UE. These measurements, together with other information concerning the surveyed geographic location of the transmitters and the relative time difference (RTD) of the actual transmissions of the downlink signals may be used to calculate an estimate of the position of the UE. Each OTDOA measurement for a pair of downlink transmissions describes a line of constant difference (a hyperbola (see NOTE 1)) along which the UE may be located. The UE's position is determined by the intersection of these lines for at least two pairs of base stations. The accuracy of the location estimates made with this technique depends on the precision of the timing measurements, the relative position of the base stations involved (see NOTE 2), and is also subject to the effects of multipath radio propagation. This is illustrated in the Figure 4.1.

NOTE 1: This is really a figure in three dimensions, a hyperboloid. For convenience here, this will be simplified to the hyperbola representing the intersection of this surface with the surface of the earth. For location service in three dimensions the hyperboloid must be considered.

NOTE 2: The geometry of the base station positions may affect the accuracy of the location estimate. The best results are when the base stations equally surround the UE. If they do not, there is a reduction in accuracy, which is sometimes termed the Geometric Dilution of Position (GDP).

The primary TDOA measurements (made by the UE) are sent to the Position Calculation Function (PCF) in the serving RNC. These measures are sent via signalling over the Uu_{lub} (and Iur) interfaces between the UE and the SRNC (PCF). The calculation function makes use of the measurements, the known locations of the transmitter sites and the relative time difference of the transmissions to estimate the UE's location.

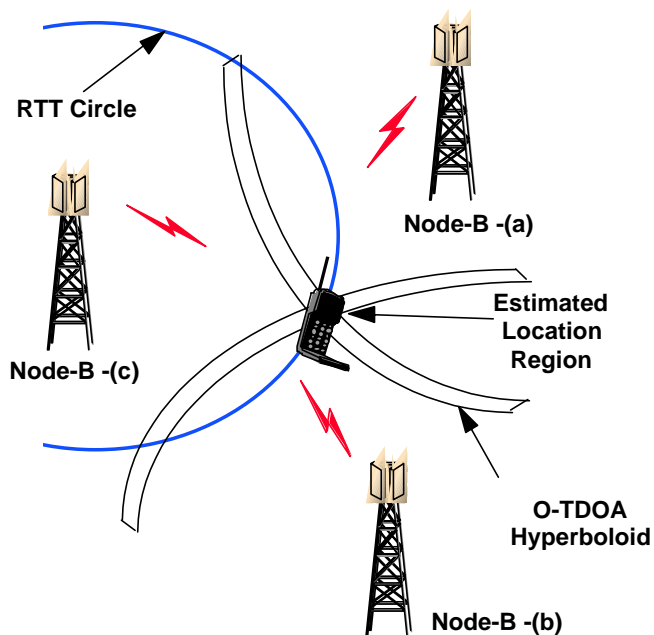

Figure 4.1: OTDOA Location Method

The OTDOA method may be operated in two modes: UE assisted OTDOA and UE based OTDOA. The two modes differ in where the actual location calculation is carried out. In the *UE assisted* mode, the UE measures the difference in time of arrival of several cells and signals the measurement results to the network, where a network element (the Positioning Calculation Function (PCF)) carries out the location calculation. In the *UE based* mode, the UE makes the measurements and also carries out the location calculation, and thus requires additional information (such as the location of the measured base stations) that is required for the location calculation. The signalling requirements for the two OTDOA modes are described in sub-section []. As the LCS involves measurements, there is always uncertainty in the results. Physical conditions, errors and resolution limits in the apparatus all contribute to uncertainty. To minimise the uncertainty in the LCS result, it is important that as many measurements of RTT and TDOA (and others) as are possible for a UE are provided to the PCF. Thus it is important that the standard method for LCS not be restricted to rely on a single measure. The UE thus provides OTDOA measures for as many pilot signals as it can receive. The pilot signals to be measured shall include those in the “cell reselection and monitoring set” and those in the “cell selection set”.

In order to support the OTDOA method, the locations of the UTRAN transmitters needs to be accurately known by the calculation function (PCF). This information may be measured by appropriate conventional surveying techniques (see NOTE). The surveyed location should be the electrical centre of the transmitting antenna (and not the location of the radio equipment building). The use of antenna diversity, beamforming or beam steering techniques may cause the effective antenna location to change with time and this information will need to be communicated to the PCF to assist with its calculations. The methods of measuring the location of the UTRAN transmitters are outside the scope of this document.

NOTE: These surveying methods may, for example, make use of a GPS receiver.

In order to support the OTDOA method, the relative time difference (RTD) of the downlink transmissions must also be known by the calculation function (PCF). If the UTRAN transmitters are unsynchronised, the RTD will change over time as the individual clocks drift. Thus, measurements of RTD may need to be made regularly and the calculation function updated appropriately. The measurement of the RTD is outside the scope of this document (see NOTE).

NOTE: One convenient method is to make use of an LMU at a fixed location. This unit measures the observed time differences of all the local transmitters and reports these to the PCF. These measures may then be converted (translated) into the actual (absolute) relative time difference for each of the transmitters by making use of the known location of the LMU and the transmitters.

In some conditions a sufficient number of downlink pilot signals may not be available for measure at the UE. This may occur, for example, if the UE is located quite close to the UTRAN transmitter and its receiver is blocked by the strong local transmissions. This is referred to as the “hearability” problem.

4.4.2.1 Use of Idle Periods

For realising location based services the support of physical layer is a prerequisite, so that the measurements required for the terminal location calculation can be carried out. In UTRAN there are several factors that must be taken into account while considering the physical layer procedures related to location services:

- hearability: a basic consequence of a CDMA radio system is that a terminal near its serving base station cannot hear other base stations on the same frequency. In order to calculate terminal location the terminal should be able to receive at least three base stations. To facilitate this some special means are required.
- asynchronous network causes significant uncertainty to the time-difference-of-arrival (TDOA) measurements. To compensate for the effects of this, the relative time difference (the synchronicity) between base station transmissions must be measured, and used for correcting TDOA measurement.
- capacity loss: signalling related to location calculation may take capacity from other services. This capacity loss should be minimised.

Based on the results of the work done in ARIB SWG2/ST9 (see reference [A1]) a solution for the above mentioned hearability problem is the IPDL (Idle Period DownLink) method. In this method each base station ceases its transmission for short periods of time (idle periods). During an idle period of a base station, terminals within the cell can measure other base stations and the hearability problem is reduced. Also, during idle periods the real time difference measurements can be carried out. Because the IPDL method is based on forward link (downlink) the location service can be provided efficiently to a large number of terminals simultaneously.

~~NOTE:~~The specification and operation of the IPDL technique are provided ~~later~~ in the following sub-section ~~[]~~.

4.4.2.1.1 Operation and specification of idle periods

There are several requirements on the provisioning of idle periods, listed in the following:

System requirements:

Many idle period pseudo random patterns

Co-located sectors shall have the same idle period timing

Operator flexibility:

Continuous operation or activated on demand

Variable average frequency of idle periods

Variable idle period length

Burst mode for regular updating of position

Implementation restrictions:

Minimum spacing between idle periods

Maximum spacing between idle periods

The following are the parameters for the idle periods (IP) :

Parameter	Min value	Max value	Bits Required	Units (see note 1)	Description
IP_spacing	2^2+1	2^6	4	frames	Number of frames between Idle Periods.
IP_status	0	1	1	Logic Value	0 = Idle Periods active in continuous mode 1 = Idle Periods active in burst mode
IP_length	5	10	1	symbols	Length of Idle Periods
Max_dev	140	145	0 (depends on IP length)	symbols	Maximum deviation in time from beginning of frame
Seed	0 - 63			(no units)	Seed for random function "rand(x)"
rand(x)	$= (106 \cdot \text{rand}(x-1) + 1283) \% 6075$.				Random function used in the calculation of the Idle Periods. Note: rand(0) = Seed.
IP_position(x)	$= x \cdot \text{IP_spacing} + \text{rand}(x) \% \text{Max_dev}$			symbols	Function for generating the exact positions of the x th Idle Period. (see notes 2 & 4 below)
Extra parameters used in the case of burst mode operation (i.e. IP_status = 1)					
Burst_Start	[0]	$[2^4-1] \cdot 256$	[4]	SFN (in steps of 256 frames)	The frame number where the 1 st Idle Period Burst occurs within an SFN cycle.
Burst_Length	[10]	$[10+2^4]$	[4]	IPs	Number of Idle Periods in a 'burst' of Idle Periods
Burst_freq	$[2^8]$	$[2^{12}]$	[4]	frames	Number of 10ms frames between consecutive Idle Period bursts.

Note 1: The unit 'symbol' refers to symbols on the CPiCH channel.

Note 2: The function IP_position(x) yields the position of the xth Idle Period relative to a) the start of the SFN cycle when in continuous mode or b) the start of a burst when in burst mode.

Note 3: The operator "%" denotes the modulo operator

Note 4: Regardless of mode of operation, the Idle Period pattern is reset at the start of every SFN cycle.

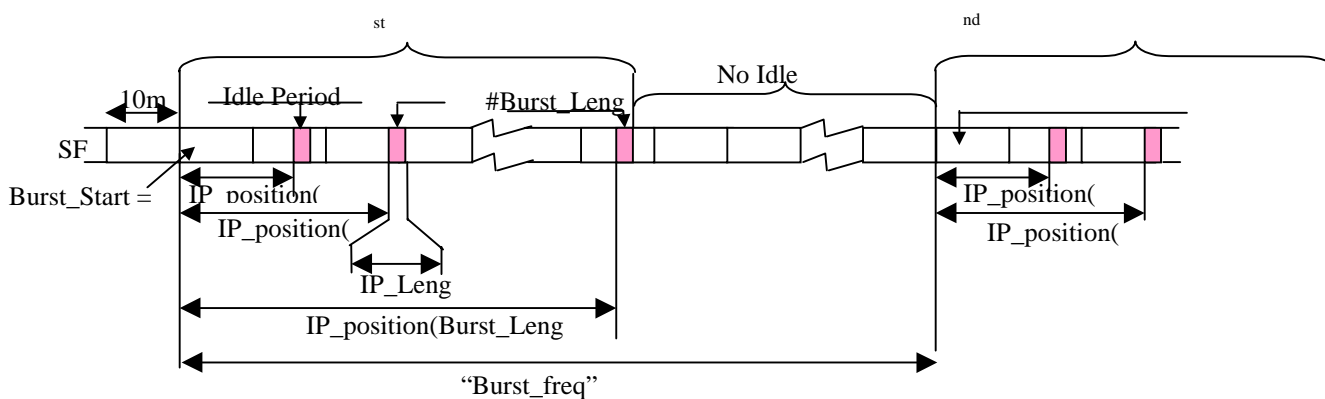

Figure 4.2: IPDL Timing

4.4.2.1.2 Time Aligned IPDL

Use of the Time Aligned method is dependent upon there being a demonstrated benefit at layer 1 and limited signalling overhead at layer 3.

In areas where traffic is high or pilot visibility is low (due for example to irregular site topology or low pilot levels), it is possible to configure IPDL in order to further increase the probability of accurate TDOA measurements. This can be achieved by approximately time aligning the occurrences of idle periods, and enabling CPICH transmission during some of these periods. The alignment can typically be to within half a CPICH symbol.

During the ‘common’ idle period, the node B transmits the CPICH randomly, pseudo-randomly or periodically. Thus in each idle period, the only radio activity will be due to the CPICH and in addition, only a fraction of node B’s are active (and this set will change for different idle periods). Finally, it is also possible to increase the CPICH power during the idle period in order to increase range for location purposes.

In this configuration, location performance is not dependent on the traffic load. Additionally, it is possible to increase the range of pilots in rural areas or for indoor coverage purposes .

Idle period alignment requires that the offsets between the transmission times of each node B be known, ideally to a resolution better than half a symbol period i.e. 33.33 μ s or less. Due to drift between different node Bs the idle period timing will need to be updated at regular intervals. The update rate is a function of network clock stability.

Measurement of time offsets can be achieved in a number of ways. A possible option is for these to be estimated by the LMUs (Location Measurement Units) which may be employed to measure the node B transmission time offsets so as to enable TOA based location as discussed in section 4.4.2.

In comparison with standard IPDL, the UE requires similar information regarding the occurrences of idle periods. Since each node B is active during a fraction of the idle periods only, complexity reduction at the UE can be obtained if knowledge of the actual activity of node Bs in the idle periods is provided, via additional signalling. In the RAN, the additional requirements to standard IPDL are:

- (a) the node B should be able to leave the CPICH on in some of the periods, possibly ramping up the power if requested to do so
- (b) signalling from the UTRAN Positioning Radio Resource Management (U-PRRM) to the node B is required to maintain partial synchronisation.

The following table provides a set of parameters which may be used to configure idle periods for both time aligned and non-time aligned operation.

<u>Parameter</u>	<u>Min value</u>	<u>Max value</u>	<u>Bits Required</u>	<u>Units</u> (see note 1)	<u>Description</u>
<u>IP_spacing</u>	<u>2</u>	<u>72</u>	<u>4</u>	<u>frames</u>	<u>Number of frames between Idle Periods (4 bit represent exponents in $2^i \times 2^j \times 3^k \times 3^l$)</u>
<u>IP_status</u>	<u>0</u>	<u>1</u>	<u>1</u>	<u>Logic Value</u>	<u>0 = Idle Periods active in continuous mode</u> <u>1 = Idle Periods active in burst mode)</u>
<u>TA_status</u>	<u>0</u>	<u>1</u>	<u>1</u>	<u>Logic value</u>	<u>0 = Time Alignment not enabled</u> <u>1 = Time Alignment enabled</u>
<u>IP_length</u>	<u>3</u>	<u>10</u>	<u>2</u>	<u>symbols</u>	<u>Length of Idle Periods</u>
<u>Max_dev</u> (S)	<u>140</u>	<u>145</u>	<u>0 (depends on IP length)</u>	<u>symbols</u>	<u>Maximum deviation in time from beginning of frame</u>
<u>Seed</u> (S)	<u>0-63</u>			<u>no units</u>	<u>Seed for random function “rand(x)”</u>

<u>rand(x)</u> (S)	$= (106 \cdot \text{rand}(x-1) + 1283) \% 6075$				<u>Random function used in the calculation of the Idle Periods. Note: rand(0) = Seed.</u>
<u>IP_position(x)</u>	$= x \cdot \text{IP_spacing} * 10 + \text{rand}(x) \% \text{Max_dev} + (\text{IP_offset}/2)$		<u>symbols</u>		<u>Function for generating the exact positions of the xth Idle Period. (see notes 2 & 4 below)</u> <u>For standard IPDL, IP_offset=0</u> <u>For TA IPDL, Max_dev=0</u>
<u>Extra parameters used in the case of the time aligned configuration</u>					
<u>IP_offset</u> (T)	<u>0</u>	$2^{15}-1$	<u>15</u>	<u>Half symbol</u>	<u>Offset giving start of idle period with respect to reference point</u>
<u>IP-CPICH_up</u> (T)	<u>0</u>	<u>15</u>	<u>4</u>	<u>dB</u>	<u>CPICH power step up relative to current level</u>
<u>IP_TA_prob</u> (T)	<u>0.2</u>	<u>0.5</u>	<u>4</u>	<u>-</u>	<u>Probability of CPICH being on during idle period</u>
<u>IP_TA_seed</u> (T)	<u>0</u>	<u>63</u>	<u>6</u>	<u>-</u>	<u>Number used to point to CPICH power on pattern in TA mode, actual pattern is for FFS (same pattern must be provided to colocated cells)</u>
<u>Extra parameters used in the case of burst mode operation (i.e. IP_status = 1)</u>					
<u>Burst_Start</u>	<u>[0]</u>	$\frac{2^4-1}{6} * 25$	<u>[4]</u>	<u>SFN (in steps of 256 frames)</u>	<u>The frame number where the 1st Idle Period Burst occurs within an SFN cycle.</u>
<u>Burst_Length</u>	<u>[10]</u>	$\frac{10+2}{4}$	<u>[4]</u>	<u>IPs</u>	<u>Number of Idle Periods in a 'burst' of Idle Periods</u>
<u>Burst_freq</u>	<u>[2⁸]</u>	<u>[2¹²]</u>	<u>[4]</u>	<u>frames</u>	<u>Number of 10ms frames between consecutive Idle Period bursts.</u>

Note 1: The unit 'symbol' refers to symbols on the CPICH channel.

Note 2: For standard IPDL, the function IP_position(x) yields the position if the xth Idle Period relative to a) the start of the SFN cycle when in continuous mode or b) the start of a burst when in burst mode. For the TA configuration the function IP_position(x) always yields the position of the xth Idle Period relative to the start of the SFN cycle (in this case, the burst parameters in burst mode define the frames when IPs are enabled).

Note 3: The operator "%" denotes the modulo operator

Note 4: Regardless of mode of operation (except TA), the Idle Periods pattern is reset at the start of every SFN cycle. For TA, the IP spacing must be kept across SFN boundaries, hence the first IP_position after a new SFN cycle should be calculated modulo (no of symbols in SFN cycle).

Note 5: (S) refers to parameter required only in standard IPDL, (T) refers to parameter required only in time aligned configuration

4.4.2.2 Accuracy

In the OTDOA technique, generally, the location is being determined by means of an estimate of the transit time (time-of-flight) of the radio signals. The radio path and the geographical path are assumed to be the same with unobstructed line-of-sight. The radio signals travel about 0,3 metres per nanosecond. To achieve an uncertainty of less than 50 metres in the location estimate requires an uncertainty in timing of less than 166 nanoseconds. With a 4 Mchip/s rate, the chip duration is 250 nanoseconds and ultimately, LCS requires timing measurements of the radio signals to the sub-chip level. Many current receivers are capable of combining multipath signal components to the sub-chip level of timing (often to better than 1/4 chip), and so such timing accuracy is already available, although in a different form.

The radio signal path is, unfortunately, not always equal to the geographic separation. The effects of multipath and obstructions combine to make the radio path typically longer (but never shorter) than the geographic path. A distance estimate derived from radio signal timing will generally be longer than the true distance. The techniques to mitigate the effects of multipath in the LCS are beyond the scope of this specification and are, in any case, subjects of current active technology research. These can be expected to improve with experience in system operation and the measurement function and calculation function designs can be expected to evolve to give better performance over the lifetime of deployed UTRAN LCS.

The accuracy of the location estimate may thus vary from area to area within an operator's territory due to the effects of multipath propagation. Some operators may choose to add extra base stations or extra transmissions to provide better location service accuracy in areas they deem critical for their service. Other operators may choose to have fewer base stations and consequently a lower accuracy service in some areas.

The objective is to provide the best estimate available with the equipment, measurements and propagation conditions prevailing at the time and place of the UE. Not all results will be of the same precision and there is a cost associated with increased precision. Making use of a downlink based measurement technique minimises the network traffic and provides a system that scales with increased usage by UE. In some jurisdictions, the equipment must meet some minimum requirements to satisfy regulatory requirements for accuracy of the location service (e.g. the FCC in the United States) and this must be taken into consideration in the design of equipment for operation in these areas.

Generally the measurement of position is a statistical process and not all measurements of the same location will yield the same result. The overall system accuracy of its reports (e.g. less than 50 metres error in 80% of measurements) will involve a statistical measure of many operations at many times and at many locations through the UTRAN coverage area. The accuracy reported together with an individual report must take into account the individual measurements, environmental conditions and the time of the measurement. The accuracy reported for an individual measurement may vary considerably from the overall system performance statistic.

4.4.2.3 Relative Time Difference (RTD)

In order to calculate the estimate of the location of the UE, the calculation function needs to know

- the OTDOA measurements,
- the surveyed geographic locations of the base stations that have had their signals measured, and
- the actual relative time difference between the transmissions of the base stations at the time the OTDOA measurements were made.

The accuracy of each of these measurements contributes to the overall accuracy of the location estimate. The measurement of the RTD is ~~FFS~~ described in the following.

There are several approaches to determining the RTD. One is to synchronise the transmissions of the base stations. In this technique the RTD are known constant values (see NOTE) that may be entered in the database and used by the calculation function when making a location estimate. The synchronisation must be done to a level of accuracy of the order of tens of nanoseconds (as 10 nanoseconds uncertainty contributes 3 metres error in the position estimate). Drift and jitter in the synchronisation timing must also be well controlled as these also contribute uncertainty in the location estimate. Synchronisation to this level of accuracy is currently only readily available through satellite based time-transfer techniques. Generally in the TDD operating mode, the base stations are synchronised.

NOTE: The transmission times may all be aligned to a common reference (such as UTC) in which case all RTD have a common value. However, in a more general case the transmissions may have a fixed offset with reference to UTC, and thus the RTD values are non-zero and may be stored in the database for use by the calculation function.

Alternatively (typically in FDD mode), the base stations may be left to free run within some constraint of maximum frequency error. In this scenario, the RTD will change (slowly) with time. The rate of change will depend on the frequency difference and jitter between base stations. If, for example, the maximum frequency difference between two base stations is $\pm 10^{-9}$, then the start of transmission of a 10 millisecond code sequence will drift through a cycle in about 1390 hours (or 57 days). With this relatively slow rate of drift the RTD can be measured by fixed units at known locations (these are LMUs, Location Measurement Units) and stored in the database for use by the calculation function. The jitter and drift of the individual oscillators in each base station may cause the change of timing to slow, remain constant or reverse direction over time. Ongoing measurements of the RTD may be made to assure the most current values are available for the calculation function. The RTD measurement units may be co-located with the base stations or installed at other convenient locations in the UTRAN coverage area, and report their results through the UTRAN signalling channels.

4.4.2.4 Time of Day (ToD)

If there are frequency differences between the (unsynchronised) base stations, as noted in the previous sub-section, the OTDOA measurements must be reported together with the time-of-day they were made (timestamp). This is necessary so that the appropriate value of the RTD may be used by the calculation function.

In order to assure less than a 20 nanosecond uncertainty in the RTD value, the time of day must be known to better than 10 seconds (if the maximum frequency difference between the base stations is $\pm 10^{-9}$). The method by which the ToD is measured is FFS [, but the frame number (which provides a 10 millisecond resolution) or encryption counter used in the downlink transmissions may provide a convenient measure].

4.4.2.5 Base Station Synchronisation

It is preferable that the location methods do not require the base station network to be synchronised. The needed level of synchronisation accuracy for LCS is not by any means straightforward to achieve. The necessary information of Relative Time Differences (RTD) between base stations can be measured by dedicated units (LMU, Location Management Measurement Unit) and distributed in the network (e.g. as broadcast information). Also, the measurements of RTD may benefit from the Idle Period DownLink (IPDL) option.

In the TDD operating mode the base stations will typically be synchronised and this may be of assistance to the LCS technique.

4.4.3 Network Assisted GPS Methods

~~NOTE: this section is provisional and still under development.~~

~~Some UE will be equipped with auxiliary equipment and software to enable them to make estimates of their location based on radio signals and techniques outside the UTRAN environment. For example, some UE may be equipped to receive general navigation signals (see NOTE). Many of these make use of satellite transmissions. These UE may be able to report their location independent of the use of the UTRAN signals.~~

~~NOTE: Two of the currently operating systems are the Global Positioning System (GPS) operated by the Defense Department of the United States, and the GLONASS system operated by the Russian Federation. A Pan-European system (Galileo) is in the planning stage.~~

~~The UTRAN radio system may also transmit auxiliary information (e.g. in its broadcast signalling channel). This information may assist the UE in its use of the navigation systems. Broadcast information could include, for example, the local, currently observable satellites, local corrections, or information to speed satellite signal acquisition. The operator may choose to specially encode (e.g. encrypt) this broadcast information to make the information only available on a subscription basis.~~

~~Some UTRAN radio systems may also transmit signals that are designed to mimic the navigation signals. The UE, equipped with a suitable receiver, may supplement the available satellite signals with the terrestrial signal(s) and thereby derive a location estimate more rapidly or more accurately than may be possible using the navigation system alone.~~

The operation of the network assisted GPS methods is described in this section.

Note: the intention is that this description be synergistic with GSM 03.71.

Methods making use of GPS are being standardised for GSM. In order to facilitate efficient implementation, and seamless location service operation between GSM and UTRAN, the support for GPS based methods must be compatible between these systems.

There are four main functions for a stand-alone GPS receiver:

- 1 Measuring distance from the satellites to the GPS receiver by determining the pseudoranges (code phases);
- 2 Extracting the TOA of the signal from the contents of the satellite transmitted message;
- 3 Computing the position of the satellites by evaluating the ephemeris data at the indicated TOA.;
- 4 Determining the position of the receiving antenna and the clock bias of the receiver by using the above data items.

To reduce the errors contributed from satellite clock and position modeling, ionospheric delay, tropospheric delay, and selective availability (SA), corrections can be done before the fourth step above. The most important technique for error compensation is DGPS.

When GPS is designed to inter-work with the UTRAN, the network assists the UE GPS receiver to improve the performance in several respects. These performance improvements will:

- Reduce the UE GPS start-up and acquisition times; the search window can be limited and the measurements sped up significantly.
- Increase the UE GPS sensitivity; location assistance messages are obtained via UTRAN so the UE GPS can operate also in low SNR situations when it is unable to demodulate UE GPS signals.
- Allow the UE to consume less handset power than with stand-alone GPS ; this is due to rapid start-up times as the GPS can be in idle mode when it is not needed.

The Network assisted GPS methods rely on signalling between reduced complexity UE GPS receivers and a continuously operating GPS reference receiver network which has clear sky visibility of the same GPS constellation as the assisted UEs. Reference GPS receivers may be connected to the UTRAN to enable derivation of UE assistance signals.

Note: labels in Figure 4.3 below may need to be aligned with GSM 03.71.

Note: charging and billing operations are not illustrated in Figure 4.3 below.

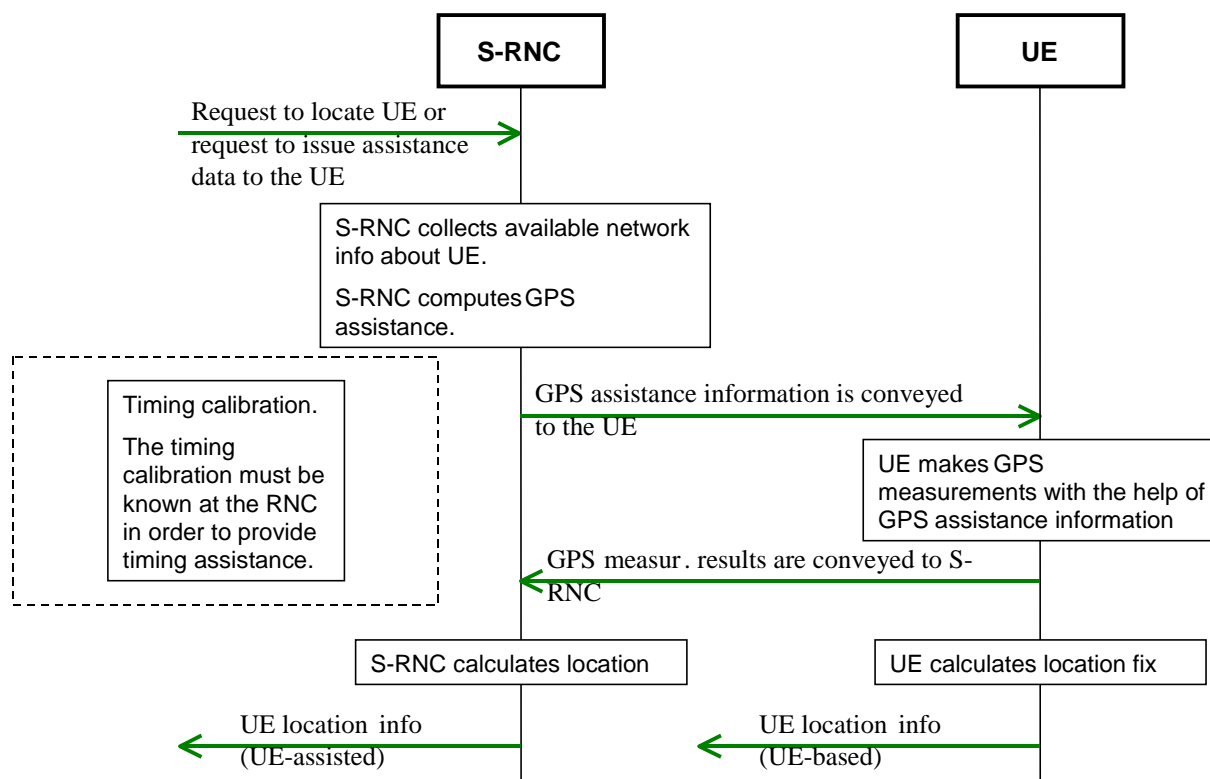

Figure 4.3: Network assisted GPS methods. (Note: see reference [1 23.171, section 8.7]).

4.4.3.1 Timing calibration

Where timing assistance is needed, the relationship between GPS Time Of Week (see reference: GSM 04.31) and cell-specific UTRAN system timing must be derived.

In the network assisted GPS methods the inter-system measurement may be used to reduce the signal search space and hence reduce the user delay in obtaining a location fix. Typically, a timing assistance accuracy of several microseconds is required for an acceptable location fix user delay. The relationship between GPS time and UTRAN timing is to be defined as GPS-UTRAN-Reference-Time in a similar way as in GSM 04.31 Annex A Section 4.2.4.

The UE or LMU optionally derives the cell specific GPS-UTRAN-Reference-Time through measurement at Layer 1.

4.4.3.2 Timing assistance

The UTRAN combines the coarse UE location determinations from UTRAN cell-specific information with the GPS-UTRAN-Reference-Time. These coarse determinations can be enhanced through other location methods (eg. IPDL). Using this information, the UTRAN computes the estimated timing of GPS signals received by the UE and conveys this information to the UE using higher layer signalling. The GPS-UTRAN-Reference-Time is uncertain to a degree depending on the accuracy of the coarse location estimate used. Typically, a window of several microseconds can be attained.

In addition, other GPS parameters, as described in section 4.4.3.3, are conveyed to the UE to further reduce the signal search space.

4.4.3.3 Data assistance

GPS signals are modulated with low-rate digital information at a rate of 50 bits/sec. This information is necessary for stand-alone GPS receivers to determine their own location (the low rate digital information conveys satellite ephemeris and other GPS data).

The UE receives GPS information (eg. Doppler shifts) through UTRAN air interface, using higher layer signalling, and modulation 'wipe-off' is applied. Therefore, the space that must be searched by the UE, to derive the GPS signals

needed, can be reduced beyond that needed by a stand-alone GPS receiver. Thus, a location fix can be derived with an acceptable sensitivity and delay to the user.

Note: “modulation wipe-off” is intended here to mean a removal of the GPS modulation in the UE through the use of the UTRAN assistance information.

The assistance data signalled to the UE may include all information listed below or a selected subset:

Data assisting the measurements; e.g. reference time, visible satellite list, satellite signal Doppler, code phase search window. This data is valid for few hours (2-4 hrs).

Data providing means for position calculation; e.g. reference time, reference location, satellite ephemeris, clock corrections. This data is valid for four hours.

If DGPS is utilized, then differential corrections may also be transmitted. They are valid for about 30 seconds. The DGPS data is valid for a large geographical area, so one centrally located reference receiver can be used to service this large region.

4.4.3.4 UE search

Application of modulation 'wipe-off' enables the UE to carry out an efficient real-time derivation of the GPS signals needed for a GPS location fix.

4.4.3.5 Location determination

Computation of the location fix can either be performed in the network infrastructure (UE-assisted) or in the UE (UE-based).

There are two types of network assisted GPS method, namely UE-based and UE-assisted, which differ according to where the actual location calculation is carried out.

4.4.3.5.1 UE-based method

The UE-based network assisted GPS method maintains a full GPS receiver in the UE, and the location calculation is carried out by the UE.

If the location was requested by an application in the network, then the calculated location is signalled to the proper network element.

4.4.3.5.2 UE-assisted method

In the UE-assisted network assisted GPS method, the UE employs a reduced complexity GPS receiver.

This carries out the pseudorange (code phase) measurements (item 1 in the list above), and transmits these to the specific network element that estimates the position of the UE and carries out the remaining GPS operations (items 2 – 4 in the list). In this method, accurately timed code phase signalling is required on the downlink. The signalling load in the uplink direction can be larger than in the UE-based method. If DGPS is performed in the UE, then differential corrections must be signalled to it. On the other hand, DGPS corrections can be applied to the final result in the network to improve the position accuracy without extra signalling to the UE.

Methods making use of the Global Positioning System (GPS) are being standardised for GSM. In order to facilitate efficient implementation, and seamless location service operation between GSM and UTRAN, the support for GPS based methods must be compatible. The signalling requirements for the GPS based methods are described in sub-section []

The Global Positioning System (GPS) method refers to any of several variants that make use of GPS signals or additional signals derived from GPS signals in order to calculate the UE's location. These variants give rise to a range of optional information flows between the UE and the network. One dimension of variation is where the position calculation is performed: a) MS based PCF or b) network based PCF. Another dimension is whether “assistance data” is required—irrespective of where position calculation is performed. Examples of assistance data include differential GPS data; lists of satellites in view based on approximate MS position, etc. A third dimension is closely related to the preceding, namely, the origin and distribution of any assistance data. For example, even while assistance data may be

required of a GPS method, it may be optional that the assistance data originates from and is distributed within and by the UTRAN.

4.5 Other methods

4.5.1 Angle of Arrival (AOA)

The location method may make use of the angle of arrival of the radio signals to estimate the UE location. This technique may, for example, make use of the sector of the base station used for receiving or transmitting to establish the location region and to assist to resolve ambiguity in other techniques. Some other techniques may make use of narrow beam antennas to resolve the direction between the UE and the base station to a very small angle.

The AOA techniques and the signalling required for their support, are FFS.

4.5.2 Observed Time of Arrival (OTOA)

The location service technique may make use of measurements of the time of arrival of signals. A UE, for example, which has available a suitable reference time, may measure the time of arrival of signals from the base stations and others sources. Some of these may include reference signals from satellites. The time-of-arrival may be used to estimate the distance from the source and hence derive a location estimate.

The OTOA technique may also be used to measure signals transmitted by the UE. Base stations which are able to receive signals from the UE, and which share a suitable reference time, may each measure the time of arrival of signals from the UE. These times-of-arrival may be used to estimate the distance to the UE and hence derive a location estimate.

The OTOA techniques and the signalling required for their support, are FFS.

4.5.3 Reference Node-Based Positioning (OTDOA-RNBP)

The RNBP method is based on the OTDOA. The main principle of the RNBP method is that it chooses a reference node for providing auxiliary measurements for its position calculating. The reference node may be a mobile equipped by a GPS receiver that provides its coordinates, a fixed or movable LCS service provider equipment, a mobile capable of using cellular relay technique (e.g. located at the soft handover area).

RNPB can also utilised with other positioning methods. It is especially useful in case of NLOS from/to the required number of neighbouring base stations. This may occur when the UE is located at the area where it may suffer from the hearability effect. Additionally it can support the LCS even in case UTRAN is not equipped by IPDL like mechanism to combat the hearability effect.

4.5.4 Round Trip Time OTDOA – Positioning Elements (OTDOA-PE)(OTDOA-RTT)

~~The RTT method (see NOTE) is based on the round trip time parameter for transmissions to and from the UE. For a UE with an active call, the serving base station measures the RTT value. To obtain RTT values when the UE is in idle mode a special call, not noticed by the subscriber (no ringing tone), may be set up. The cell ID of the serving cell or sector and the RTT is determined. The RTT measurement describes a circle (or arc within a sector) along which the UE may be located. This circle (or arc) may be combined with other techniques to resolve position ambiguity or to improve accuracy of other techniques. The accuracy of the position estimates made with this technique depends on the precision of the timing measurements, delays in the UE and is also subject to the effects of multipath radio propagation. The RTT may be used to assist all positioning mechanisms and as a fallback procedure. If the UE is operating in the soft handover mode, the RTT will generally be that of the primary serving base station, although timing may also be available from other participating base stations.~~

~~NOTE — This is similar to the Timing Advance method used in the GSM location service.~~

The PE method is based on OTDOA and makes use of Positioning Elements (PE) located within the coverage area. PEs are placed in accurately known positions other than those of the Node B equipment. They synchronize to the downlink in a cell and transmit their symbols at predefined - or signaled - offsets with regard to the arrival of the beginning of the BCH frame at the PE position. The offsets may be chosen to have a fixed relation to the occurrence of the idle periods in

each cell. Each PE transmits a different and identifying code which is selected from the group of codes to which the 16 SSC codes belong to. The use of other signals (e.g. CIPCH) instead of SSC codes is for further study.

The time difference which is observed and reported by the UE is the difference – with respect to the time of arrival at the UE - between the first path of the BCH from the serving cell and the first path of the 256 chip code transmitted by a PE. The measurements result in an estimate of the UE distance to the PEs.

PE deployment is optional and may be used in conjunction with other positioning methods in order to increase positioning accuracy in certain areas or to achieve a minimum desired accuracy in locations where reception of satellites and/or base stations other than the serving one is problematic (indoors, edge of cellular coverage, etc.). It may also be used as a stand alone method.

5 UTRAN LCS Architecture

The Figure 5.1 shows the general arrangement of the Location Service feature. This illustrates, generally, the relation of LCS Clients and servers in the core network with the UTRAN. The definition and operation of LCS entities operating in the core network is outside the scope of this document. The LCS entities within the UTRAN communicate with the Core Network (CN) across the Iu interface. Communication among the UTRAN LCS entities makes use of the messaging and signalling capabilities of the UTRAN.

As part of their service or operation, the LCS Clients may request the location information of User Equipment (UE) (UE without a valid SIM/USIM) or mobile stations. There may be more than one LCS client. These may be associated with the core network, associated with the UTRAN, operated as part of a UE application or accessed by the UE through its access to an application (e.g. through the Internet).

Within the UTRAN, typically the serving RNC, receives authenticated requests for LCS information from the core network across the Iu interface. LCS entities then manage the UTRAN resources, including the Node-Bs (base stations), LMU, the UE and calculation functions, to estimate the location of the UE and return the result to the CN.

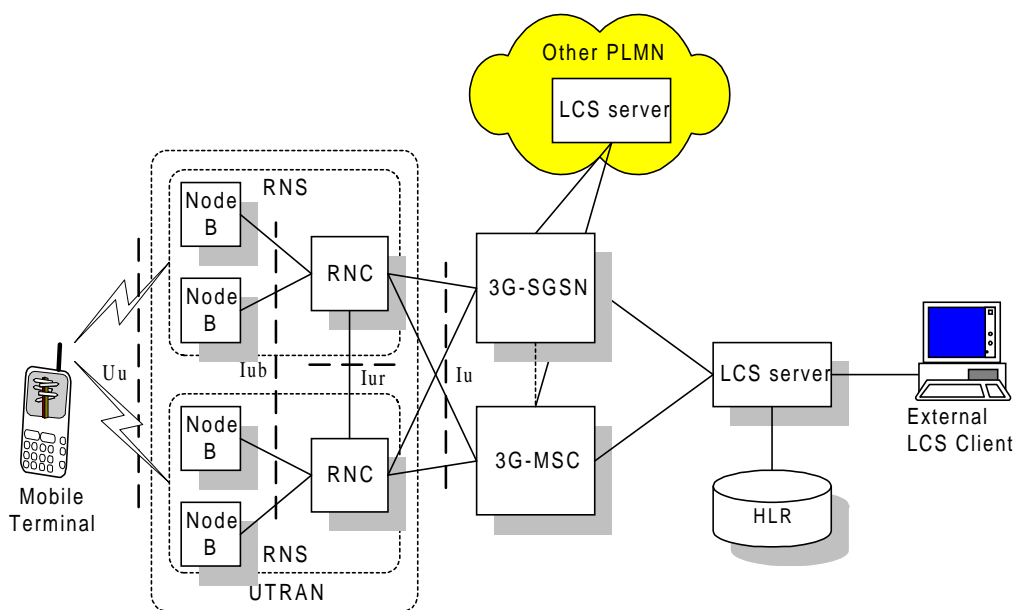

Figure 5.1: General arrangement of LCS in UMTS

NOTE: This figure requires some revision and will be the same as in the system specification.

5.1 LCS Operations

The UTRAN LCS entities receive authenticated requests for location information that originate in external applications across the Iu interface (for validated UE subscriptions). The details of the operations in the UMTS may be found in reference [4].

Interworking between the External LCS Applications and the LCS entities within UTRAN is outside the scope of this specification.

The operation begins with a Client or an application requesting location information for a UE from the LCS functional entities in the Core Network. The LCS functional entities in the Core Network will (the details of these operations in the Core Network are beyond the scope of this document):-

- verify that the LCS request and application are authorised
- verify that LCS is supported by the UE
- establish whether it is allowed to locate the UE or subscriber in question for privacy or other reasons

- ~~— establish under which RNC the UE is likely to reside, by paging the UE if necessary~~
- ~~— request the UTRAN (via the serving RNC) to provide location information for an identified UE, with indicated QoS~~
- ~~— receive information about the location of the UE from UTRAN and forward it to the Client~~
- ~~— send appropriate accounting information to an accounting function.~~

The schematic functional description of LCS operations in UMTS is defined in [1].

~~The~~ Upon request from the UMTS LCS entities or for internal operations, the UTRAN LCS functional entities will:

- request measurements, typically from the UE and one or more Node-B radio apparatus,
- send the measurement results to the appropriate calculating function within UTRAN,
- receive the result from the calculating function within UTRAN,
- perform any needed co-ordinate transformations,
- send the results to the LCS entities in the core network or to application entities within UTRAN,

In the event that the client is internal to UTRAN the request may be made directly to the UTRAN LCS entities as the internal clients are considered to be “pre-authorised”.

As part of its operation, the UTRAN LCS calculating function may require additional information. This may be obtained by the function directly by communication with a database, or it may be through a request to UTRAN LCS entities that will mediate the request and return of information from the appropriate database (or databases if more than one is needed to fulfil the requests). ~~The LCS application may make use of the position information itself, or further process and then forward the information to other authorised applications within or external to the UTRAN.~~

There may possibly also be available independent information that is able to supply the location information directly, or may be able to supply auxiliary information to the calculation function. The UTRAN LCS co-ordination function, as part of its activity to supervise the location process, may query the UE or other elements of the UTRAN to determine their capabilities and use this information to select the mode of operation.

This general operation is outlined in the following (generic) sequence diagram Figure 5.2. This figure is not intended to show the complete LCS operation for UTRAN, but to simply to outline the basis for operation.

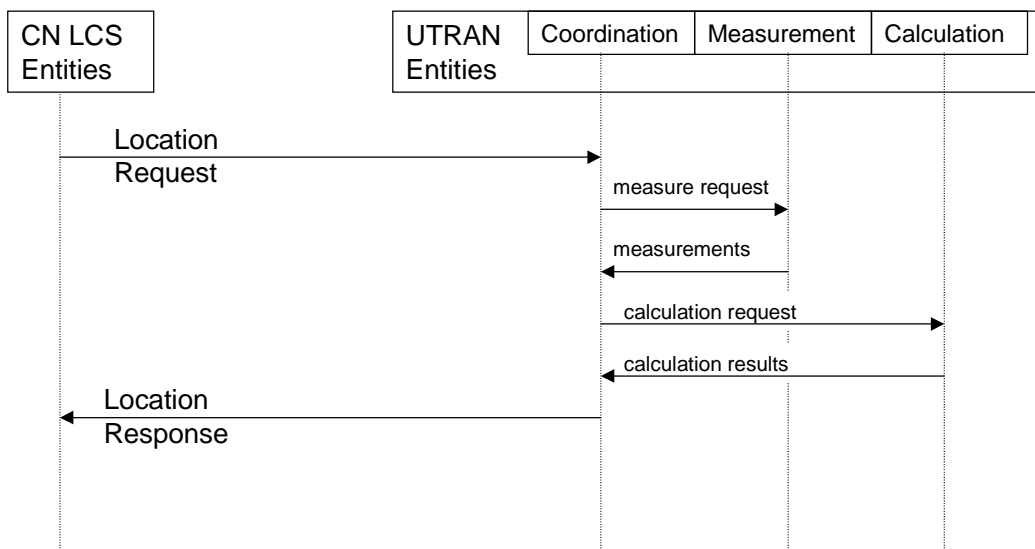

Figure 5.2: General sequence for LCS operation

5.2 High-Level Functions

Several functional groupings may be defined to describe the LCS. These groupings occur in both the Core Network and the UTRAN. The overall LCS functional grouping is described in reference [1]. Each grouping encompasses a number of functional components and functions.

The functions within the UTRAN are described in more detail in the following sub-sections of this document.

Within UTRAN the functional entities may be grouped as follows :

- The Internal Client group,
- The UTRAN System Handling group,.
- The Positioning group.

5.2.1 Co-ordination, Measurement and Calculation Functions

These UTRAN functions (including functions in the System handling and Positioning groups) provide the co-ordination, measurement and calculation functions needed to provide a location estimate. The functions interface with the requesting application and select the appropriate location method and speed of response. The functions co-ordinate the operations of the radio and measurement equipment to transmit the needed signals and to make the needed measurements. The measurements may be made by Node-Bs, radio apparatus associated with the Node-B or separate Location Measurement Units (LMU) that may be associated with Node-B, independently located or remote (i.e. communicating over the Uu interface).

The functions may also access databases or other sources of information appropriate for the location method. The functions also provide the calculation functions appropriate for the location method to estimate the UE location and the accuracy of the report. The functions may also make co-ordinate translations to the geographic co-ordinate system requested by the application. The functions also may record information on the usage of the LCS that may be used for administrative purposes (e.g. forwarded to a billing function in the Core Network). If needed by the location method, the functions will ensure the broadcast of information and gather and update information concerning UTRAN operating parameters (e.g. timing of Node-B transmissions) needed for LCS operations.

These entities are mainly concerned with the location method, controlling the radio equipment and performing the calculations to determine the location and thus may be associated with the RNC in the UTRA access network. These functions may receive location requests from either the core network or from applications internal to the UTRAN.

The UTRAN LCS entities may also request the subscription and authorisation functions in the core network to authenticate an application or a UE subscription or to verify the subscriber privacy parameters.

These functions communicate with the core network across the Iu interface, with other entities in the UTRAN across the Iur interface and with the Node-B and LMU across the Iub interface and with the UE and the remote LMU across the Uu interface.

5.3 UTRAN LCS Functional Entities

The diagram of the UTRAN LCS functional entities is shown in Figure 5.3. In this arrangement, the LCS clients in the core network communicate with the UTRAN LCS entities across the Iu interface. The LCS RNC Handling Entities and the Positioning Handling Entities work together with the UE to measure and calculate the location information for the requested target UE. These entities within the UTRAN are described in more detail in the following sub-sections.

The figure shows the general arrangement of the Location Service feature in UTRAN. LCS entities are added to the UTRAN to provide the location service. Communication among these entities makes use of the messaging and signalling capabilities of the UTRAN across the Iu, Iur, Iub and Uu interfaces. A Location Measurement Unit (LMU) is also added to the UTRAN to make measurements as needed by the selected location method.

This figure does not include elements of the next generation mobile Core Network, but focuses on those that participate with the LCS functions in the UTRAN. The association of the LCS entities within the Core Network (CN) (e.g. with 3G-MSC or 3G-SGSN) is outside the scope of this document and is not illustrated in the diagram.

Within the UTRAN, the LCS Entities may be associated with, or part of the RNC, the Node-B and the UE. Internal LCS Applications may also be part of the RNC and the UE.

The mobile positioning calculation function (PCF) is logically associated with the Serving RNC in UTRAN.

The LCS in UMTS also makes use of the standardised Iur interface between RNCs, when base station information, measurements and results are collected.

The functional model presented in the figure includes functional entities for UE utilising either or both circuit switched (CS) and packet switched (PS) services. This model also supports all the entities needed for different positioning methods (e.g. network based, mobile based, mobile assisted, and network assisted (see NOTE) positioning) exploiting either uplink or downlink measurements.

NOTE: In this approach mobile station may use the GPS positioning mechanism but still make use of auxiliary information from the serving network.

Implementations may often associate the UTRAN LCS Entities with an RNC (as illustrated in the figure). However, for networks with a small volume of LCS requests, the LCS Entities in the UTRAN may also be implemented as a separate element (server) which interfaces with the RNCs, and the Node-B/LMUs.

NOTE: the Interface to be used for this separated LCS Entity is for further study.

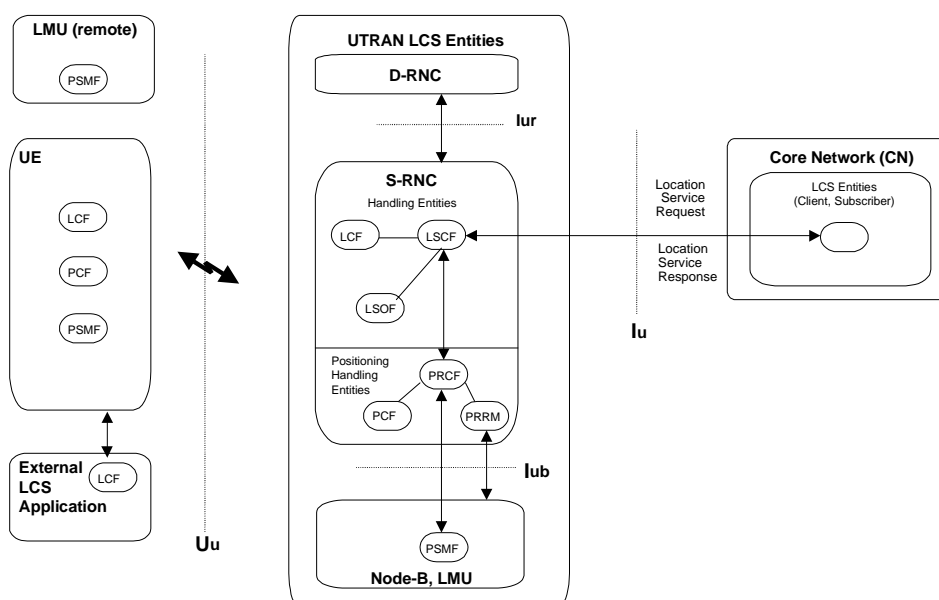

Figure 5.3: UTRAN LCS Functional Entities

5.3.1 Internal Client Group

5.3.1.1 Internal UTRAN Location Client Function (U-LCF)

The Location Client Function (U-LCF) represents a logical interface between the internal UTRAN LCS applications and the LCS RNC Handling entities (e.g. the Location System Control Function (U-LSCF) in the RNC).

NOTE: There is not necessarily a requirement for a LCCF (Location Client Control Function) for the UTRAN Internal Client as is described for external clients in reference [1] (the system stage specification).

The UTRAN may make use of location information for internal operations such as location assisted handover. In such a case, a U-LCF representing the internal UTRAN LCS application may communicate with the U-LSCF to request and receive the location information.

5.3.2 UTRAN System Handling group

5.3.2.1 UTRAN Location System Control Function (U-LSCF)

The UTRAN Location System Control Function in RNC is responsible for co-ordinating location requests within the RNC handling entity. This function manages call-related and non-call-related location requests and allocates network resources for handling them. This function “insulates” the Location clients in the Core Network from the detailed operation of the location method in order that the UTRAN may be used by several types of core network and with several location methods.

The U-LSCF provides flow control between simultaneous location requests. Simultaneous location requests must be queued in a controlled manner to account for priority requests (e.g. for Emergency Clients). The details of the flow control, priority selection and queuing are beyond the scope of this document.

The U-LSCF will select the appropriate location method based on the availability of resources and parameters of the location request. The U-LSCF coordinates resources and activities needed to obtain data (e.g. base station geographic coordinates) needed for the location method. It also records LCS RNC usage data for the location service request that may be passed to a Location System Recording Function (U-LSRF) or OA&M function in the Core Network.

If the location technique requires the broadcast of system information, the LSCF initiates and maintains this activity through the Positioning Radio Co-ordination Function (U-PRCF). Broadcast information (such as the geographic coordinates of the base stations) may be required, for example, to support a Position Calculation Function (U-PCF) located in the mobile unit (UE). These broadcasts may also include other information (such as currently observable satellites) that may assist a UE in the use of external location services.

The information to be broadcast is selected based on the location techniques offered for use by the LCS and the needs of the UE. This broadcast information may be specially coded (i.e. encrypted) to ensure its availability only to subscribers of the service. The use of broadcasts or other methods for signalling to the UE or the LMU may be selected based on the chosen location method.

The information to be broadcast could include, for example:

- Identification and spreading codes of the neighbouring base stations (the channels that are used for measurements),
- Real-Time-Difference (RTD), i.e. the timing offsets, asynchronicity between base stations, could be based on measurement results obtained by LMUs,
- Roundtrip delay estimates in connected mode,
- The geographic location, coordinates, of the neighbouring base stations,
- The idle period places within the frame structure for multiple base stations,
- The local time-of-day

Some of this information may be broadcast to support other UTRAN operations (e.g. handover). The function of the LSCF is to ensure information is broadcast when needed for the LCS operations and the LSCF may make use of other UTRAN processes to do so.

If there are frequency differences between the (unsynchronised) base stations, the OTDOA measurements must be reported together with the time-of-day they were made (timestamp). This is necessary so that the appropriate value of the RTD may be used by the calculation function.

5.3.2.2 UTRAN Location System Operations Function (U-LSOF)

The Location System Operations Function (LSOF) is responsible for provisioning of data, positioning capabilities, data related to clients and subscription (LCS client data and UE data), fault management and performance management of LCS within the RNC.

An LSOF may be associated with each entity. The LSOF interacts with Internal (OAM) Clients for administration and maintenance of the data.

5.3.3 Positioning group

5.3.3.1 UTRAN Positioning Radio Co-ordination Function (U-PRCF)

The UTRAN Positioning Radio Control Function manages a location request for a UE through overall co-ordination and scheduling of resources to perform location measurements. This function interfaces with the U-PSMF, the U-PRRM and the U-PCF. The U-PRCF determines the location method to be used based on the location request, the QoS, the capabilities of the UTRAN, and the UE's capabilities. The U-PRCF also manages the needed radio resources through the U-PRRM. It determines which U-PSMFs are to be involved, what to measure, and obtains processed signal measurements from the U-PSMF.

Some location methods may involve measurements made at the UE. In this case the U-PRCF interfaces with the UE to obtain the measurements (or the location results if they have been determined by the UE). Some location methods may involve measurements or information from several sources, including radio units at several Node-B (or other Location Measurement Units (LMU)) and involve a series of transmissions and receptions. The U-PRCF entity also provide ancillary measurements in case of network-assisted positioning mechanism. Ancillary information may be extracted from navigating systems like GPS.

The U-PRCF forwards the signal measurement data to the U-PCF.

It is the function of the U-PRCF to co-ordinate the sequence of activities and compensate for failures (if they occur) to provide the location estimate.

5.3.3.2 UTRAN Positioning Calculation Function (U-PCF)

The UTRAN Positioning Calculation Function is responsible for calculating the location of the UE (mobile unit). This function applies an algorithmic computation on the collected signal measurements to compute the final location estimate and accuracy.

The U-PCF may also support conversion of the location estimate between different geographic reference systems. It may obtain related data (e.g., base station geographic co-ordinates) needed for the calculation. There may be more than one calculating function available within, or associated with, the positioning entity of the UTRAN.

The Position Calculation Function is also responsible for estimating the accuracy of the location estimate. This accuracy estimate should include, for example, the effect of geometric dilution of precision (GDP), the capabilities of the signal measuring hardware, the effects of multipath propagation and the effects of timing and synchronisation unknowns. The accuracy should be returned as a measure of distance in the same units as the location estimate. The accuracy zone may be reported as the axis and orientation of an ellipse surrounding the location estimate.

5.3.3.3 UTRAN Positioning Signal Measurement Function (U-PSMF)

The UTRAN Positioning Signal Measurement Function (U-PSMF) is responsible for performing and gathering uplink or downlink radio signal measurements for use in the calculation of a UE's location. These measurements can be location related or ancillary.

There may be one or more PSMF within a UTRAN and they may be located at the UE, the Node-B, or a separate Location Measurement Unit (LMU). The PSMF, generally, may provide measurement of signals (i.e. satellite signals) in addition to measurements of the UTRA radio transmissions. The measurements to be made will depend on the selected location method.

5.3.3.4 UTRAN Positioning Radio Resource Management (U-PRRM)

The UTRAN Positioning Radio Resource Management entity is responsible for managing the effect of LCS operations on the overall performance of the radio network. This may ensure, for example, that the operation of the U-PSMF does not degrade the QoS of other calls. The U-PRRM handles following functions:

- Controlling the variation of the UL and DL signal power level due to the LCS application.
- Calculating the DL and UL power/interference due to UE location operations
- To admit/reject the new LCS requests.

- Co-operating with Admission Control, and entities of the RRM (such as power control) to provide the system stability in terms of radio resources.
- Controlling the RTD measurement mechanism. It may also forward the results of the RTD; ATD (or any similar timing parameter) measurements to the PRCF (or PCF).
- Controlling the IPDL mechanism for location measurements. This may include the overall control of the periodical measurement fulfilment. Co-ordination among RNC (e.g. to assure non-overlapping idle periods) will be communicated through the Iur interface.

5.4 Assignment of LCS Functional Entities to UTRAN Elements

The preceding Figure 5.3 and the following Table 5.1 show the generic configuration for different positioning methods, including network-based, mobile-based, mobile-assisted and network-assisted positioning methods. With this approach both the network and the mobiles are able to measure the timing of signals and compute the mobile's location estimate. Depending on the applied positioning method it is possible to utilise the corresponding configuration containing all needed entities. For instance, if network-based positioning is applied, the entities that are involved in measuring the mobile's signal and calculating its location estimate are allocated to the network elements of the access stratum. On the other hand, in case mobile-based or network-assisted methods are used these entities should be allocated to the mobile station.

Table 5.1: Example Allocation of LCS Functional Entities to Network Elements

U-	UE	Node-B	LMU	RNC
LCF	X			X
LSCF				X
PRCF				X
PCF	X			X
PRRM				X
PSMF	X	X	X	
LSOF	X	X	X	X

5.5 Functional Description of UTRAN LCS Network elements

5.5.1 Radio Network Controller (RNC)

5.5.1.1 Serving RNC

NOTE: Adapted from 03.71, to be elaborated for UTRAN.

The Serving RNC (SRNC) is a network element of UTRAN and contains functionality required to support LCS in one PLMN.

The SRNC manages the overall coordination and scheduling of resources required to perform positioning of a mobile. It also calculates the final location estimate and estimates the achieved accuracy.

The SRNC may control a number of LMUs for the purpose of obtaining radio interface measurements to locate or help locate MS subscribers in the area that it serves. The SRNC is administered with the capabilities and types of measurement produced by each of its LMUs. Signaling between an SRNC and LMU is transferred using the Iub interface, sometimes the Iur interface[and also the Uu interface for possible stand-alone LMUs]. The following measurements returned by an LMU to an SRNC have a generic status in being usable for more than one position method:

- Radio interface timing information

The SRNC and GMLC are connected through the 3G-VMSC or 3G-SGSN. When the VMSC and GMLC are in different PLMNs, they are interconnected via the Lg interface.

5.5.1.2 Other RNC

5.5.2 Node-B

5.5.3 Location measurement unit (LMU)

There are two types of LMU, the LMU associated with the Node-B and a “stand-alone LMU”. The associated LMU signalling is associated with a Node-B, and the “stand-alone LMU” signalling passes over the Uu interface.

The Location Measurement Unit LMU entity makes measurements (e.g. of radio signals) and communicates these measurements to the PRCF. The LMU contains a PSMF and also may also perform calculations associated with the measurements.

The LMU may be associated with the Node-B and make use of its radio apparatus and antennas. Alternatively, the LMU may be separated from the Node-B, but communicate with the PRCF via the Node-B Iub interface. These “Independent LMU” may communicate to the PRCF via the Uu interface or may otherwise communicate to the PRCF (through an interface yet to be defined).

The LMU may make its measurements in response to requests (e.g. from the PRCF), or it may autonomously measure and report regularly (e.g. timing of Node-B transmissions) or when there are significant changes in radio conditions (e.g. changes in the RTD).

There may be one or more LMU associated with the UTRAN and an LCS request may involve measurements by one or more LMU. The LMU may be of several types and the PRCF will select the appropriate LMUs depending on the LCS method being used.

The LMU may be used, for example, to measure UTRA radio transmissions either uplink or downlink. These measurements may be made either, for example, to locate the UE or to measure a system parameter needed by the LCS system such as the timing offset (RTD) of transmissions of two or more base stations. The LMU may also measure other transmissions, such as those of satellite navigation systems (i.e. the Global Positioning System (GPS)) and either report the measurements for use by the PCF of the LCS system, or report the location results as determined by internal calculations of the LMU.) The details of the measurements to be made by the LMU will be set by the chosen LCS method.

5.5.4 UE

NOTE: the following text is provided as a basis.

The UE interacts with the measurement co-ordination functions to transmit the needed signals for uplink based LCS measurements and to make measurements of downlink signals. The measurements to be made will be determined by the chosen location method.

The UE may also contain LCS applications, or access an LCS application through communication with a network accessed by the UE or an application residing in the UE. This application may include the needed measurement and calculation functions to determine the UE’s location with or without assistance of the UTRAN LCS entities.

The UE may also, for example, contain an independent location function (e.g. Global Satellite Positioning Service GPS) and thus be able to report its location, independent of the UTRAN transmissions. The UE with an independent location function may also make use of information broadcast by the UTRAN that assists the function.

6 Interfaces and Information Flow

NOTE: This chapter describes the information flows, the detailed messages and protocols is described in other chapters.

6.1 Generic information flow for LCS in UMTS

The following diagram illustrates the operations for the OTDOA-LCS when the request for location information is initiated by an LCS application signalled from the Core Network. As these operations are internal to the RNC, this diagram is to illustrate information flow and implementations may use alternate arrangements.

This illustration only includes the information flow related to LCS operations and does not indicate other operations that may be required, for example, to establish a signalling connection between the UE and the SRNC. Also not illustrated is the signalling used to initiate the location service request (from the Location Client Function) from the Core Network or a UE based application.

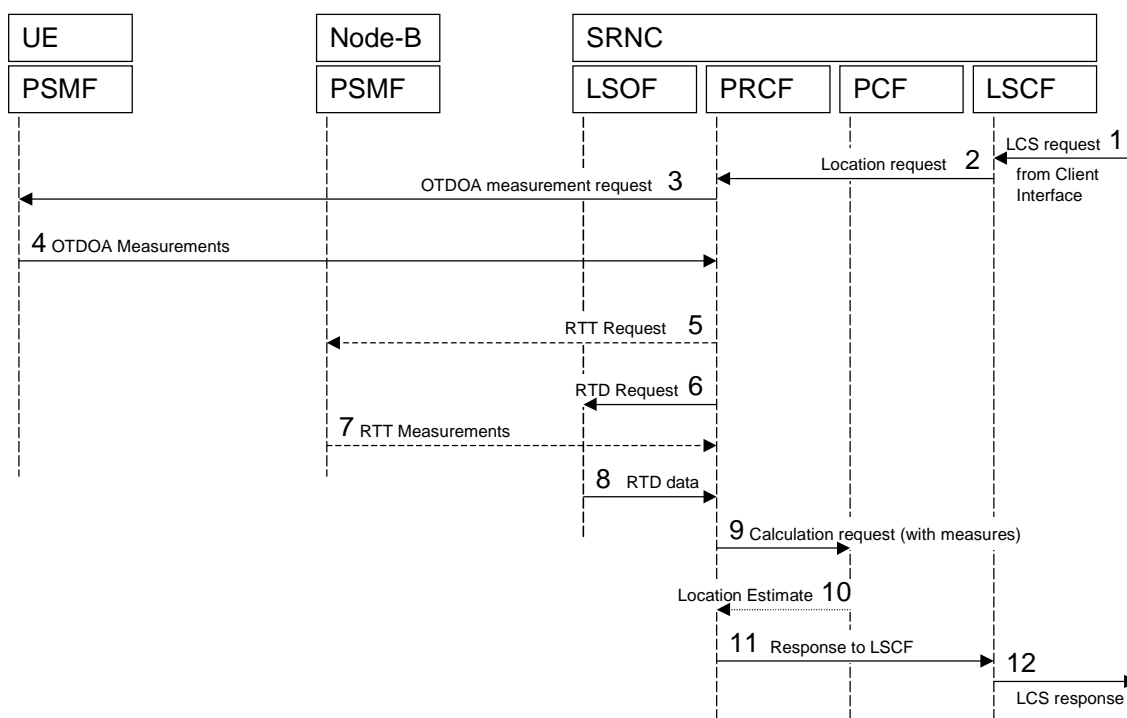

Figure 6.1: OTDOA Signalling Operations

1. The OTDOA operation begins with an authenticated request for location information about a UE from an application in the core network being received at the LSCF. The LSCF acts as interface between the Core Network and the LCS entities in the UTRAN.
2. The LSCF considers the request and the capabilities of the UE and the network and forwards the request to the appropriate PRCF in the Serving RNC.
3. The PRCF requests from the UE the measurement of the OTDOA for the signals in the active and neighbourhood sets. These measurements may be made while the UE is in the idle state or while it is connected.
4. The UE returns the OTDOA measures to the PRCF. The PRCF receives the OTDOA information and coordinates obtaining other information to support the calculation request (not illustrated).
5. If there are insufficient OTDOA measures, or it is otherwise considered advantageous to do so, the PRCF requests the RTT measure for the UE from the PSMF in the serving Node-B.

6. The PCRF requests the RTD measures for the associated transmitters from the LSOF (database). These may be stored locally if they are constant over time, otherwise they must be updated to represent the RTD timing at the time-of-day the OTDOA measurements were made.
7. The PSMF in the Node-B returns the RTT measures to the PCRF if they were requested.
8. The LSOF returns the RTD information to the PCRF.
9. The PCRF passes the OTDOA, RTD and, if necessary, RTT information to the PCF and requests a location calculation. The calculation may include a co-ordinate transformation to the geographic system requested by the application.
10. The PCF returns the location estimate to the PCRF. This estimate includes the location, the estimated accuracy of the results and the time of day of the estimate.
11. The PCRF passes the location estimate to the LSCF.
12. The LSCF passes the location estimate to the Core Network.

6.2 Interfaces

There are four interfaces through which the LCS entities communicate. These are the Iu, the Iur, Iub and the Uu.

NOTE: the interfaces between the Internal or External LCS applications and the 3G-MSC or 3G-SGSN are outside the scope of this document.

6.2.1 Iu Interface

The Iu interface is used to communicate between the LCS functional entities in the Core Network and the LCS entities in the UTRAN. Further specification of the messages and operations for LCS across the Iu interface may be found in reference [4].

~~This interface passes the location requests and responses from authenticated external and internal LCS applications between the LCS entities in the Core Network and the UTRAN LCS entities. The location request will include parameters to indicate the preferred location method and the quality of service (QoS). The QoS parameters will include the required speed of response, the preferred co-ordinate system and the required accuracy. The location results, error (failure) responses, and accounting/OAM information will be returned from the LCS entities in the UTRAN to the LCS entities in the core network.~~

~~The LCS entities in the UTRAN may also request from the core LCS entities information concerning the client subscriptions and UE privacy conditions that may be needed to support internal LCS application requests.~~

~~The Iu interface may also pass messages relating to records of operational usage of the LCS within UTRAN or reporting of the data associated with the Location System Operations Functions (LSOF) in the UTRAN. These may be used by the core network for accounting, billing or administration functions.~~

6.2.1.1 Information Flows between UTRAN and CN

~~The information flows pass over the Iu interface between the UTRAN and the CN. These flows shall abide with a well-defined protocol, which is specified in reference [1].~~

6.2.1.1.1 Location Service Request

~~Via the Location Service Request, the LCS client communicates with the LCS server to request for the location information of one or more than one MS within a specified quality of service. There exist two types of location service requests:~~

- ~~— Location Immediate Request (LIR); and~~
- ~~— Location Deferred Request (LDR).~~

~~The following attributes are identified for Location Service Request information flow.~~

~~NOTE:—this list is subject to further review~~

~~—Target MS ;~~

~~-Indication of what positioning methods are supported by the Target MS, generated based on MS Classmark~~

~~NOTE:—This and other parameters to indicate MS support of LCS is ffs.~~

~~—LCS identity;~~

~~—State (idle, dedicated)~~

~~—Event (applicable to LDR requests only);~~

~~—Requested Quality of Service information;~~

~~—Estimated achieved QoS;~~

~~—Local coordinate reference system;~~

~~—Location of MS as an ellipsoid with axes and direction of all axis~~

~~—Location indication of MS in geographical coordinates~~

~~-Geographical area~~

~~NOTE:—Should be checked with the meaning of "Geographical area" in 03.71.~~

~~—Indication when MS enters or leaves the Geographical area,~~

~~6.2.1.1.2 Location Service Response~~

~~The LCS Server sends the Location Service Response to the LCS client as the result of the Location Service Request:~~

~~—Immediate Response; and~~

~~—Deferred Response;~~

~~These deferred responses can be either single or periodic.~~

6.2.2 Iur Interface

LCS operations at the Iur interface are defined in [14].

The Iur interface is used to communicate between the LCS functional entities associated with the serving RNC and other RNC in the UTRAN. The Iur interface is also used to communicate between the serving RNC and the Internal LCS Applications in the UTRAN. The LCS entities associated with the serving RNC are responsible for co-ordinating and responding to location requests received from the LCS entities in the core network or Internal Clients

When communicating between the serving RNC and the UTRAN Internal LCS Applications (ILA), the messages and protocols are the same as those used over the Iur interface.

The Iur interface is also used to communicate between the LCS Entities in the serving RNC and those in other RNC. The location method, for example, may require measurements by several LMU or Node-B, some of which may be associated with other RNC. Commands and responses from these LCS Entities are communicated over the Iur interface. In some cases, the LCS Entities in the serving RNC may make use of entities associated with other RNC. For example, a calculating function (PCF) may be used in another RNC if the serving RNC is too busy or does not contain the function or database information required by the chosen location method.

The Iur interface may also pass messages relating to changes or reporting of the data associated with the Location System Operations Function (LSOF) in the RNC.

Iur shall be used for LCS signalling whenever it is available, even in the case when the RNCs connected to different 3G-MSCs or 3G-SGSN.

Within UTRAN, Iur supports inter-RNC soft handover. Inter-RNC handover should also include LCS, meaning that whenever an inter-RNC soft handover occurs, Iur should be able to support the functionality of the positioning entities in RNCs, including PCF, PRRM, PSMF, and LSOF.

In addition, in case of SRNC relocation Iur should support the relocation mechanism in order for DRNC to be able to handle the responsibility of SRNC in LCS process. That is, to transfer the PCF, PRRM, PSMF, and LSOF functionality from SRNC to DRNC. Iur shall be used also to collect RTD and other LCS information from base stations under different RNCs that are not involved in handover.

6.2.2.1 Signalling between RNCs

6.2.3 Iub Interface

LCS operations at the Iub interface are defined in [15].

The Iub interface is used to communicate among the LCS entities associated with the serving RNC, the Node-B and the associated Location Measurement Units (LMU).

This interface passes the request for measurements, the measurement results and requests for LCS related transmissions or other radio operations needed by the location method (e.g. broadcast of parameters needed for a UE based location method).

The Iub interface may also pass messages relating to changes or reporting of the data associated with the Location System Operations Function (LSOF) in the Node-B or the LMU.

6.2.3.1 Signalling between RNC and Node B (LMU)

6.2.4 Uu Interface

LCS operations at the Uu interface are generally defined in [1]. This specification defines in more detail the procedures needed for messaging for each individual location method.

The Uu interface is used to communicate among the LCS entities associated with the RNC, the UEs and the stand-alone Location Measurement Units (LMU). (The Uu interface is also used to communicate between the LCS entities in the core network and the UE. Those communications are beyond the scope of this specification.)

This interface may pass measurement requests and results to and from the UE or the stand-alone LMU.

The Uu interface may also pass location requests from internal or external LCS Applications at the UE.

NOTE: These requests may require the services of the LCS entities associated with the core network to authenticate clients and subscriber subscriptions to aspects of the LCS.

The Uu interface may also be used for broadcast of information that may be used by the UE or stand-alone LMU for their LCS operations. This may, for example, include timing and code information about nearby Node-B transmissions that may assist the UE or LMU in making their measurements.

The Uu interface may also pass messages relating to changes or reporting of the data associated with the Location System Operations Function (LSOF) in the UE or the remote LMU.

6.2.4.1 Signalling between RNC and Target UE

6.2.4.1.1 OTDOA-IPDL

There are two modes of operation for the OTDOA method. In the *UE assisted* mode, the UE measures the difference in time of arrival of several cells and signals the measurement results to the network, where a network element (the Positioning Calculation Function (PCF)) carries out the location calculation. In the *UE based* mode, the UE makes the measurements and also carries out the location calculation, and thus requires additional information (such as the location of the measured base stations) that is required for the location calculation. This information is provided by the Location System Information Function (LSIF).

Table 6.1 lists the required information for both OTDOA modes. The range of values for the listed parameters are FFS. The required information can be signalled to the UE either in a broadcast channel or partly also as dedicated signalling.

Table 6.1: Information required for UE assisted and UE based OTDOA in the UTRAN (LSIF) to UE direction
 ('Yes' = information required, 'No' = Information not required)

Information	UE assisted OTDOA	UE based OTDOA
Intra frequency Cell Info (neighbour list).	Yes	Yes
Ciphering information for LCS NOTE: The idea behind LCS specific ciphering information is e.g. that the operator can sell information that the UE needs for calculating its location. For reference in the GSM world see [3].	No	Yes
Measurement control information (idle period locations)	Yes	Yes
Sectorisation of the neighbouring cells	No	Yes
Measured RTD values for Cells mentioned at Intra frequency Cell Info	No	Yes
RTD accuracy	No	Yes
Measured roundtrip delay for primary serving cell	No	Yes
Geographical location of the primary serving cell.	No	Yes
Relative neighbour cell geographical location	No	Yes
Accuracy range of the geographic location values	No	Yes

The information required from UE to UTRAN (PSMF/PCF) is listed in Table 6.2.

Table 6.2: Information required for UE assisted and UE based OTDOA in the UE to UTRAN (PSMF/PCF) direction

Information	UE assisted OTDOA	UE based OTDOA
OTDOA measurement results	Yes	No
OTDOA measurement accuracy	Yes	No
UE geographical location	No	Yes
Location accuracy indicator (based on the signalled and measurement accuracies)	No	Yes

6.2.4.1.2 GPS Assisted

These methods make use of UE which are equipped with radio receivers capable of receiving signals from the Global Positioning System (GPS).

The following definitions of “Network-Based”, “Mobile-Based” and “Assisted” may be applied :

1. Mobile-Based positioning

The UE performs signal measurements and computes its own location estimate.

2. Mobile-Assisted (UE-Assisted Network-Based) positioning

The UE performs and reports signal measurements to the network and the network computes the UE's location estimate. In addition to those we can have following variant:

3. Network-Assisted UE-Based positioning

The network performs and reports signal measurements to the UE and the UE computes its own location estimate.

Thus, if GPS is utilised with this mechanism (Network-Assisted UE-Based GPS) it means that the location calculation is fulfilled in UE by using the additional measurements from the network to perform a better location estimate. One example of this kind is using of Differential GPS data.

UE-Based GPS can be either independent or dependent on network measurements. If it is dependent on the network measurements (then it can be Network-Assisted, UE-Based GPS). The main point is that where the location estimate is finally calculated and from where the assistance data is originated.

6.2.4.1.2.1 Network Assisted, UE Based (GPS)

In this method, the UE includes a GPS receiver which is capable of measuring and calculating the UE location based on the GPS signals. The operation of this receiver is assisted by information supplied by the UTRAN (LSIF). The GPS acquisition and location calculation is assisted by the following information that may be signalled from the UTRAN (LSIF) to the UE:

- Number of satellites for which assistance is provided
- Reference time for GPS
- Reference location
- Ionospheric corrections
- Satellite ID for identifying the satellites for which the assistance is provided
- IODE: sequence number for the ephemeris for the particular satellite
- Ephemeris to accurately model the orbit of the particular satellite and information when this becomes valid
- Clock corrections
- DGPS corrections
- Almanac data

The location information message from UE to the UTRAN (PSMF/PCF) contains the location calculated based on GPS measurements. The message may contain the following information:

- Reference time for which the computed position is valid
- Serving cell information
- Latitude/Longitude/Altitude/Error ellipse
- Velocity estimate of the UE
- Satellite ID for which the measurement data is valid
- Whole/Fractional chips for information about the code-phase measurements
- C/N_0 of the received signal from the particular satellite used in the measurements.
- Doppler frequency measured by the UE for the particular satellite signal
- Pseudorange RMS error
- Multipath indicator

6.2.4.1.2.2 Network Based, UE Assisted (GPS)

In this method, the UE includes a GPS receiver which is capable of measuring the GPS signals. The operation of this receiver is assisted by information supplied by the UTRAN (LSIF). The GPS measurements are signalled to the UTRAN (PSMF/PCF) where the Positioning Calculation Function determines the UE location. The GPS acquisition is assisted by the following information that may be signalled from the UTRAN (LSIF) to the UE :

- Number of Satellites
- Reference Time for GPS
- SVID/PRNID
- Doppler (0th order term)

- Doppler (1st order term) (optional)
- Doppler Uncertainty (optional)
- Code Phase
- Integer Code Phase
- GPS Bit Number
- Code Phase Search Window
- Azimuth
- Elevation

The GPS measurement message from UE to the UTRAN (PSMF/PCF) contains the following information measured from the GPS :

- Number of Pseudoranges
- Reference Time for GPS
- SVID/PRNID
- Satellite C/No
- Doppler
- Satellite Code Phase – Whole Chips
- Satellite Code Phase – Fractional Chips
- Multipath Indicator
- Pseudorange RMS Error

6.2.4.1.3 Round Trip Time (RTT)

This method makes use of measurements by the Node-B or LMU of the round trip time for transmissions to and from the UE. The RTT measurement message from Node-B or LMU to the UTRAN (PSMF/PCF) contains the following information :

- Round trip time (in fractional chips)
- Time of measurement
- Received sector
- Doppler of received signal (Hz)
- Multipath Indicator

7 General UMTS location procedures

NOTE: To be adapted from GSM 03.71

- 7.1 State description for RNC (for LCS)
- 7.2 State description for LMU (stand-alone)
- 7.3 State description for Node-B (for LCS)
- 7.4 General network positioning procedures
- 7.5 Exception procedures

8 Positioning method management (signalling flows)

NOTE: Here are the detailed messages and the protocols for LCS contributions are invited on these topics.

- 8.1 OTDOA positioning
 - 8.1.1 Idle Period DownLink timing procedures (IPDL)
 - 8.1.2 Reference Node-Based positioning
 - 8.1.3 Round Trip Time Positioning
- 8.2 Network assisted GPS positioning

9 Position calculation functionality

NOTE: The functionality of the PCF is described in more detail in an informative annex FFS.

10 Information storage

NOTE This section just outlines the information that may need to be stroed in the UTRAN LCS elements (U-LCF, U-PSCF,U-LSCF, UE, etc) that may need to be standardised (if any).

11 Operational aspects

Annex A (Informative): Definitions and Terms

This annex provides definitions and terms for the general LCS. Not all of these are applicable to the UTRAN environment.

CAMEL: CAMEL is a network functionality, which provides the mechanisms of Intelligent Network to a mobile user

Current Location: after a location attempt has successfully delivered a location estimate and its associated time stamp, the location estimate and time stamp is referred to as the 'current location' at that point in time.

Deferred location request: a location request where the location response (responses) is (are) not required immediately.

Global Positioning System: The Global Positioning System (GPS) consists of three functional elements: Space Segment (satellites), User Segment (receivers), and Control Segment (maintenance etc.). The GPS receiver calculates its own position based on the received time differences for several satellites.

Immediate location request: a location request where a single location response only is required immediately.

Initial Location: in the context of an originating emergency call the location estimate and the associated time stamp at the commencement of the call set-up is referred to as 'initial location'.

Last Known Location: The current location estimate and its associated time stamp for Target MS stored in the LCS Server is referred to as the 'last known location' and until replaced by a later location estimate and a new time stamp is referred to as the 'last known location'.

LCS (LoCation Services): LCS is a service concept in system (e.g. GSM or UMTS) standardisation. LCS specifies all the necessary network elements and entities, their functionalities, interfaces, as well as communication messages, due to implement the positioning functionality in a cellular network.

NOTE:LCS does not specify any location based (value added) services except locating of emergency calls

LCS Client: a software and/or hardware entity that interacts with a LCS Server for the purpose of obtaining location information for one or more Mobile Stations. LCS Clients subscribe to LCS in order to obtain location information. LCS Clients may or may not interact with human users. The LCS Client is responsible for formatting and presenting data and managing the user interface (dialogue). The LCS Client may reside in the Mobile Station (MS).

LCS Client Access barring list: an optional list of MSISDNs per LCS Client where the LCS Client is not allowed to locate any MSISDN therein.

LCS Client Subscription Profile: a collection of subscription attributes of LCS related parameters that have been agreed for a contractual period of time between the LCS client and the service provider.

LCS Feature: the capability of a PLMN to support LCS Client/server interactions for locating Target MSs.

LCS Server: a software and/or hardware entity offering LCS capabilities. The LCS Server accepts requests, services requests, and sends back responses to the received requests. The LCS server consists of LCS components, which are distributed to one or more PLMN and/or service provider.

Local Service: A service, which can be exclusively provided in the current serving network by a Value added Service Provider.

Local Information: Information related to a given location, or general information, which is made available in a given location.

Location (Based) Application: A location application is an application software processing location information or utilising it in some way. The location information can be input by a user or detected by network or MS. Navigation is one location application example.

Location Based Service (LBS): A service provided either by teleoperator or a 3rd party service provider that utilises the available location information of the terminal. Location Application offers the User Interface for the service. LBS is either a pull or a push type of service (see Location Dependent Services and Location Independent Services). In

ETSI/GSM documentation of SoLSA, LBS is called "Location Related Service". ETSI and/or 3GPP –wide terminology harmonisation is expected here.

Location Dependent Service: A service provided either by teleoperator or a 3rd party service provider that is available (pull type) or is activated (push type) when the user arrives to a certain area. It doesn't require any subscription in advance, but the push type activation shall be confirmed by the user. The offered service itself can be any kind of service (e.g. a public Xerox machine or the discount list in a store).

Location Estimate: the geographic location of an MS and/or a valid Mobile Equipment (ME), expressed in latitude and longitude data. The Location Estimate shall be represented in a well-defined universal format. Translation from this universal format to another geographic location system may be supported, although the details are considered outside the scope of the primitive services.

Location Independent Service: A service provided either by teleoperator or a 3rd party service provider that is available and therefore can be activated anywhere in the network coverage. It is activated by the user's request or by other user's activated service, and therefore it requires a subscription in advance (pull type). The offered service itself can be any kind of service (e.g. MMS, SWDL, or LBS!).

PLMN Access barring list: an optional list of MSISDN per PLMN where any LCS Client is not allowed to locate any MSISDN therein except for certain exceptional cases.

Positioning (/location detecting): Positioning is a functionality, which detects a geographical location (of e.g. a mobile terminal).

Positioning method (/locating method): A principle and/or algorithm which the estimation of geographical location is based on, e.g. AOA, TOA, TDOA. For example, GPS is based on TOA, and E-OTD (on GSM) is based on TDOA.

Positioning technology (/locating technology): A technology or system concept including the specifications of RF interfaces, data types, etc. to process the estimation of a geographical location, e.g. GPS, E-OTD (GSM), and IPDL-TDOA (WCDMA).

Predefined area: A geographical area which is not related to cell or radio coverage. The mobile may take special action when it recognises it has entered or left a predefined area.

Privacy Class: list of LCS Clients defined within a privacy exception class to which permission may be granted to locate the target MS. The permission shall be granted either on activation by the target MS or permanently for a contractual period of time agreed between the target MS and the service provider.

Privacy Exception List: a list consisting of various types of privacy classes (i.e. operator related, personal etc.). Certain types of classes may require agreement between the service provider and the target MS.

Prohibited area: An area where the mobile must not activate its transmitter. The Prohibited area may be a Predefined area described above or related to radio cell(s).

Subscription Profile: the profile detailing the subscription to various types of privacy classes.

Target MS: the MS being positioned.

History

Document history		
V1.4.0	October 1999	Created on the basis of TR 25.923 V1.4.0 according to decision in TSG RAN #5 meeting. Editorial updates following 3GPP drafting rules by Hans van der Veen.