

8th – 10th December 2004. Athens, Greece.

Source: CN3
Title: TS 29.162 v2.0.0. interworking between the IM CN subsystem and IP networks (for approval)
Agenda item: 9.11
Document for: APPROVAL

Presentation of Specification to TSG or WG

Presentation to: TSG CN Meeting #26
Document for presentation: 29.162, Version 1.3.0
Presented for: Approval

Abstract of document:

This document details the interworking between the IM CN subsystem and external IP networks for IM service support. The IP version Interworking, between IP version 4 and IP version 6 is detailed.

Changes since last presentation at TSG CN Meeting #25

Editorial updates and completion of IP version interworking

Outstanding Issues:

none

Contentious Issues:

none

3GPP TS 29.162 V1.3.0 (2004-11)

Technical Specification

3rd Generation Partnership Project; Technical Specification Group Core Network; Interworking between the IM CN subsystem and IP networks (Release 6)



The present document has been developed within the 3rd Generation Partnership Project (3GPPTM) and may be further elaborated for the purposes of 3GPP.

The present document has not been subject to any approval process by the 3GPP Organizational Partners and shall not be implemented. This Specification is provided for future development work within 3GPP only. The Organizational Partners accept no liability for any use of this Specification. Specifications and reports for implementation of the 3GPPTM system should be obtained via the 3GPP Organizational Partners' Publications Offices.

Keywords

3GPP

Postal address

3GPP support office address

650 Route des Lucioles - Sophia Antipolis
Valbonne - FRANCE
Tel.: +33 4 92 94 42 00 Fax: +33 4 93 65 47 16

Internet

<http://www.3gpp.org>

Copyright Notification

No part may be reproduced except as authorized by written permission.
The copyright and the foregoing restriction extend to reproduction in all media.

© 2004, 3GPP Organizational Partners (ARIB, ATIS, CCSA, ETSI, TTA, TTC).
All rights reserved.

Contents

Foreword.....	4
1 Scope	5
2 References	5
3 Definitions, symbols and abbreviations.....	6
3.1 Definitions	6
3.2 Symbols	6
3.3 Abbreviations	6
4 General	7
4.1 General interworking overview	7
4.2 Interworking scenarios	7
4.2.1 UE with 3GPP SIP profile capability connecting to an external SIP device.....	7
5 Network characteristics	8
5.1 Key characteristics of IP Multimedia Networks.....	8
5.2 Key characteristics of UMTS IM CN Subsystem.....	8
6 Interworking with IP networks	8
6.1 Interworking Reference Model for control plane interworking and user plane interworking	8
6.1.1 Interworking Functional Entities.....	9
6.1.1.1 S-CSCF	9
6.1.1.2 MRFP	9
6.1.1.3 MRFC.....	9
6.2 Control plane interworking model.....	9
6.2.1 IM CN Subsystem originated calls	9
6.2.2 IM CN Subsystem terminated calls.....	9
6.3 User plane interworking model	9
6.4 IP version interworking model	10
6.4.1 Interworking functional entities	10
6.4.1.1 IMS-ALG	10
6.4.1.2 TrGW	10
7 Control plane interworking.....	10
7.1 SIP with 3GPP Profile to Standard SIP Interworking	10
8 User Plane Interworking	11
8.1 Overview	11
8.2 Transparent User Plane.....	11
8.3 Non Transparent User Plane.....	11
9 IP Version Interworking at the IMS-ALG/TrGW	11
9.1 Control plane interworking.....	11
9.1.1 Originating Session Set-up to IPv4 SIP network	11
9.1.1.1 Receipt of the first SDP offer	11
9.1.1.2 Receipt of the first SDP answer.....	11
9.1.2 Terminating Session set-up from IPv4 SIP network	12
9.1.2.1 Receipt of an SDP offer.....	12
9.1.2.2 Receipt of SDP answer.....	12
9.1.3 Change of connection information.....	12
9.1.4 Release of the session	12
9.2 User plane transport.....	13
Annex A (informative): Codecs used for Conversational Services.....	14
Annex B (informative): Change history.....	15

Foreword

This Technical Specification has been produced by the 3rd Generation Partnership Project (3GPP).

The contents of the present document are subject to continuing work within the TSG and may change following formal TSG approval. Should the TSG modify the contents of the present document, it will be re-released by the TSG with an identifying change of release date and an increase in version number as follows:

Version x.y.z

where:

- x the first digit:
 - 1 presented to TSG for information;
 - 2 presented to TSG for approval;
 - 3 or greater indicates TSG approved document under change control.
- y the second digit is incremented for all changes of substance, i.e. technical enhancements, corrections, updates, etc.
- z the third digit is incremented when editorial only changes have been incorporated in the document.

1 Scope

The IM CN subsystem interworks with the external IP networks through the Mb reference point.

This document details the interworking between the IM CN subsystem and external IP networks for IM service support. It addresses the issues of control plane interworking, user plane interworking and IP version interworking.

The IP version Interworking, between IP version 4 RFC 791 [9] and IP version 6 RFC 1883 [10] detailed in terms of the processes and protocol mappings required in order to support both mobile originated and terminated calls.

2 References

The following documents contain provisions which, through reference in this text, constitute provisions of the present document.

- References are either specific (identified by date of publication, edition number, version number, etc.) or non-specific.
- For a specific reference, subsequent revisions do not apply.
- For a non-specific reference, the latest version applies. In the case of a reference to a 3GPP document (including a GSM document), a non-specific reference implicitly refers to the latest version of that document *in the same Release as the present document*.

- [1] 3GPP TS 24.229: "Internet Protocol (IP) multimedia call control protocol based on Session Initiation Protocol (SIP) and Session Description Protocol (SDP); Stage 3".
- [2] IETF RFC 3261: "SIP: Session Initiation Protocol".
- [3] 3GPP TS 23.221: "Architectural requirements".
- [4] 3GPP TS 29.061: "Interworking between the Public Land Mobile Network (PLMN) supporting packet based services and Packet Data Networks (PDN)".
- [5] 3GPP TS 23.002: "Network architecture".
- [6] 3GPP TS 26.235: "Packet switched conversational multimedia applications; Default codecs".
- [7] 3GPP TR 21.905: "Vocabulary for 3GPP Specifications".
- [8] 3GPP TS 23.228: "IP Multimedia Subsystem (IMS); Stage 2".
- [9] IETF RFC 791: "Internet Protocol".
- [10] IETF RFC 2460: "Internet Protocol, Version 6 (IPv6) Specification".
- [11] IETF RFC 2766: "Network Address Translation - Protocol Translation (NAT-PT)".
- [12] IETF RFC 2663: "IP Network Address Translator (NAT) Terminology and Considerations".
- [13] 3GPP TR 29.962 version 6.1.0: "Signalling interworking between the 3GPP profile of the Session Initiation Protocol (SIP) and non-3GPP SIP usage".
- [14] ITU-T Recommendation H.263: "Video coding for low bit rate communication".
- [15] ITU-T Recommendation G.723.1: "Dual rate speech coder for multimedia communications transmitting at 5.3 and 6.3 kbit/s".
- [16] ITU-T Recommendation G.729: "Coding of speech at 8 kbit/s using conjugate-structure algebraic-code-excited linear-prediction (CS-ACELP)".
- [17] ITU-T Recommendation G.711: "Pulse code modulation (PCM) of voice frequencies".

- [18] IETF RFC 792: "Internet Control Message Protocol"
- [19] IETF RFC 2463: "Internet Control Message Protocol (ICMPv6) for the Internet Protocol Version 6"
- [20] IETF RFC 2765: "Stateless IP/ICMP Translation Algorithm (SITT)"

3 Definitions, symbols and abbreviations

3.1 Definitions

For the purposes of the present document, the terms and definitions given in 3GPP TR 21.905 [7] and the following apply:

IM CN subsystem: (IP Multimedia CN subsystem) comprises of all CN elements for the provision of IP multimedia applications over IP multimedia sessions

IP multimedia session: set of multimedia senders and receivers and the data streams flowing from senders to receivers IP multimedia sessions are supported by the IP multimedia CN Subsystem and are enabled by IP connectivity bearers (e.g. GPRS as a bearer). A user may invoke concurrent IP multimedia sessions.

3.2 Symbols

Void.

3.3 Abbreviations

For the purposes of the present document, the following abbreviations apply:

CSCF	Call Session Control Function
GTP	GPRS Tunnelling Protocol
IETF STD	Internet Engineering Task Force STandard
IM	IP Multimedia
IMS	IP Multimedia Subsystem
IMS-ALG	IMS - Application Level Gateway
IP	Internet Protocol
IPv4	IP version 4
IPv6	IP version 6
LAN	Local Area Network
MEGACO	MEdia GAteway COntrol
MRFC	Multimedia Resource Function Controller
MRFP	Multimedia Resource Function Processor
NA (P) T-PT	Network Address (Port-Multiplexing) Translation-Protocol Translation
PDN	Packet Data Network
QoS	Quality of Service
S-CSCF	Serving-CSCF
SIP UA	SIP User Agent
SIP	Session Initiation Protocol
TrGW	Translation GateWay
UE	User Equipment
WAN	Wide Area Network

4 General

4.1 General interworking overview

The IM CN Subsystem interworks with SIP RFC 3261 [2] based IP Multimedia networks. These IP Multimedia networks include:

- SIP User Agents (UAs);
- SIP Servers.

As such, the IM CN Subsystem has to be able to interwork to all of these above functional entities in the IP multimedia network, as there is a possibility that they all may be involved in an IM session. The general interworking model is shown in figure 1. The SIP based Multimedia networks may use IP version 4 RFC 791 [9] or IP version 6 RFC 1883 [10].

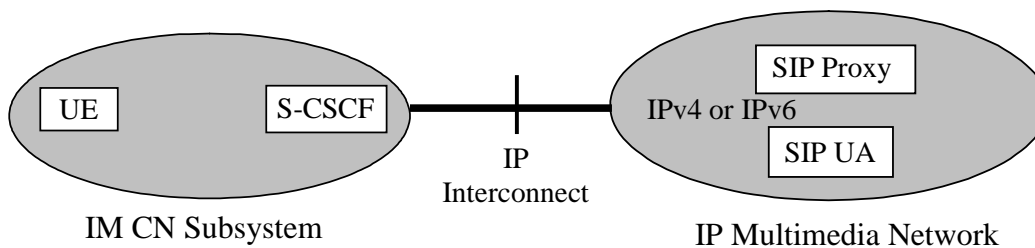

Figure 1: Interworking Model for IM CN Subsystem to IP Multimedia Network

The UE uses the CSCF in order to communicate with the external IP multimedia network entities.

If no IP version interworking is required, the CSCF can communicate with SIP UAs in an external IP multimedia network directly.

If no IP version interworking is required, the CSCF can also communicate with SIP proxies in an external IP multimedia network directly, which in turn can then communicate with SIP UAs.

To provide the IP version interworking the functions of an IMS-ALG and a TrGW may be inserted between the CSCF and external IP Multimedia Network by configuration. The IMS-ALG and the TrGW may be implemented as a part of other physical entities in the IMS.

NOTE: Other methods to provide IP version interworking are for further study.

4.2 Interworking scenarios

3GPP specifications design the IM CN subsystem elements and interfaces to exclusively support IPv6. 3GPP TS 23.221 [3] details the interoperability scenarios that an UE may experience when interworking with an external PDN. All of these IP transport layer interworking scenarios can apply to the application layer interworking scenarios detailed in clause 4.2.1.

4.2.1 UE with 3GPP SIP profile capability connecting to an external SIP device

The procedures used by an UE with 3GPP SIP profile to connect to an external SIP device, which may lack 3GPP SIP profile capabilities, have been analysed in Release 6 within 3GPP TR 29.962 [13] and are specified in 3 GPP TS 24.229 [1].

5 Network characteristics

5.1 Key characteristics of IP Multimedia Networks

The Internet is a conglomeration of networks utilising a common set of protocols. IP protocols are defined in the relevant IETF RFCs. The networks topologies may be based on LANs (e.g. Ethernet), Point-to-Point leased lines, PSTN, ISDN, X.25 or WANs using switched technology (e.g. SMDS, ATM).

IP multimedia networks provide the ability for users to invoke IP multimedia applications in order to send and receive (where applicable) voice and data communications. One protocol used to manage IP multimedia sessions is the Session Initiation Protocol (SIP) (RFC 3261 [2]).

5.2 Key characteristics of UMTS IM CN Subsystem

The UMTS IM CN subsystem uses the SIP protocol to manage IP multimedia sessions, and uses IP as the transport mechanism for both SIP session signalling and media transport.

The UMTS IM CN subsystem shall support interworking with existing fixed and mobile voice and IP data networks, including PSTN, ISDN, Mobile and Internet.

6 Interworking Reference Model for control plane interworking and user plane interworking

Figure 2 details the reference architecture required to support interworking between the IM CN subsystem and IP networks for IM services. Figure 3 details the reference architecture required to support interworking between the IMS and IP SIP networks supporting IP version 4.

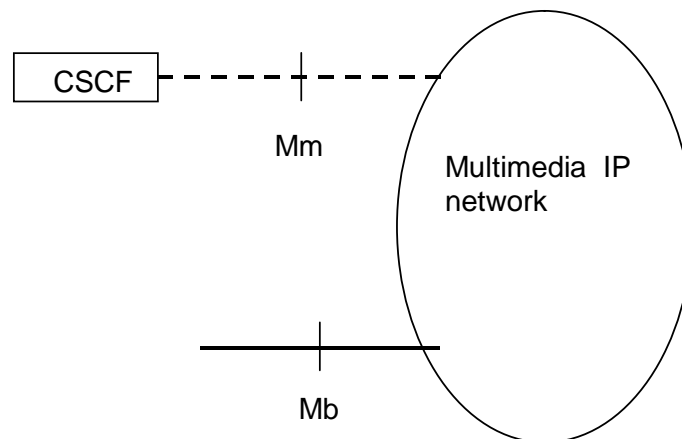

NOTE: Multimedia IP networks may be connected via the Mb interface to various network entities, such as an UE (via an GTP Tunnel reaching to the GGSN), an MRFP, or an application server.

Figure 2: IM CN Subsystem to IP network interworking reference Architecture without IP version interworking

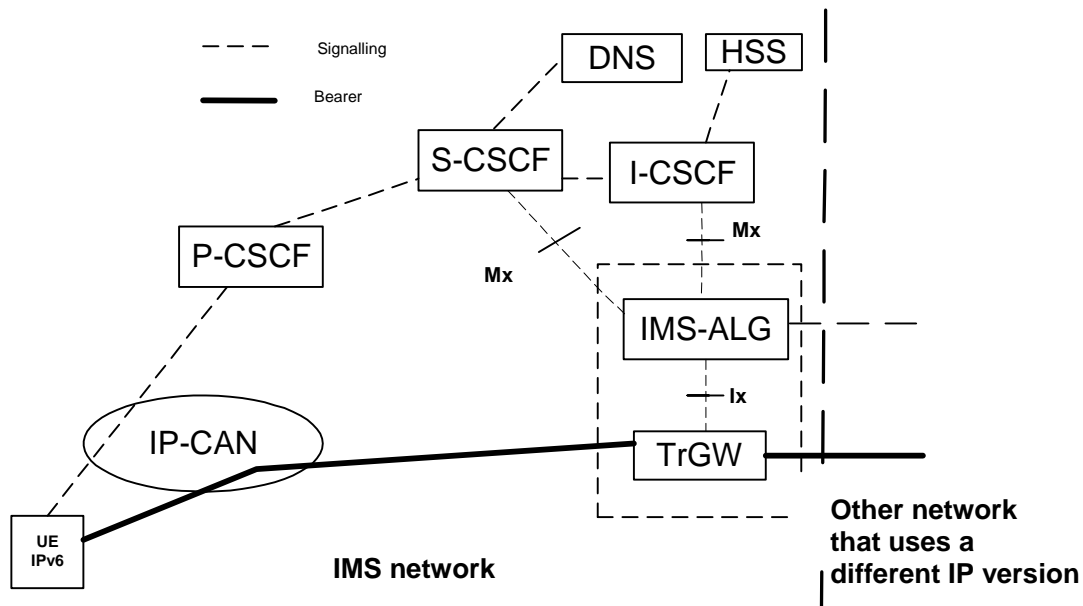

Figure 3: Model for IP version interworking

Mm reference point: The call control protocol applied to the Mm interface between CSCF and external IP networks is SIP, RFC 3261 [2], as detailed in 3GPP TS 24.229 [1]. SIP extension packages mandated by 3GPP are possibly not supported.

Mb reference point: This interface is defined in 3GPP TS 23.002 [5] and is IP based. Further information is provided in 3GPP TS 29.061 [4] and 3GPP TS 26.235 [6].

Mx reference point: The protocol applied at the Mx reference point is not specified within this release of the specification.

Ix reference point: The protocol applied at the Ix reference point is not specified within this release of the specification.

6.1 Interworking Functional Entities

6.1.1 S-CSCF

This entity provides control plane functionality to connect entities following the 3GPP profile of SIP, TS 24.229 [1], and external SIP entities following RFC 3261 [2].

6.1.2 IMS-ALG

An IMS ALG provides the application level translation function for SIP and SDP in order to communicate between IPv6 and IPv4 SIP applications. The IMS-ALG is a SIP Back-to-Back User Agent.

6.1.3 TrGW

The TrGW is a NAT-PT/NAPT-PT, which uses a pool of globally unique IPv4 addresses for assignment to IPv6 nodes on a dynamic basis as sessions are initiated across the IP version boundaries. NAT-PT binds addresses in IPv6 network with addresses in IPv4 network and vice versa to provide transparent routing between the two IP domain without requiring any changes to end points. NAPT-PT provides additional translation of transport identifier (TCP and UDP port numbers). More detailed information on the NAT-PT/NAPT-PT is given in RFC 2766 [11] and RFC 2663 [12].

7 Control plane interworking

7.1 SIP with 3GPP Profile to Standard SIP Interworking

3GPP TS 24.229 [1] defines the procedures, which allow a 3GPP-IMS UE to connect to a standard SIP terminal.

8 User Plane Interworking

8.1 Overview

The present specification addresses user plane interworking between codec types used for either speech or video. Codecs used for conversational services in the PS domain are as defined in 3GPP TS 26.235 [6]. Codecs of particular interest are described in annex A

8.2 Transparent User Plane

The user plane may be transported through the IM CN subsystem without being processed by any IM CN subsystem entity.

8.3 Non Transparent User Plane

The MRFP may provide transcoding of the user plane if a codec mismatch occurs. It is not specified in the present release how the MRFP is inserted and controlled to provide transcoding.

9 IP Version Interworking at the IMS-ALG/TrGW

9.1 Control plane interworking

9.1.1 Originating Session Set-up to IPv4 SIP network

9.1.1.1 Receipt of the first SDP offer

At the receipt of the first SDP offer the IMS-ALG:

- Provides to the TrWG the IPv6 address(es) and port number(s) as received in the c-line(s) and m-line(s) in the SDP, and
- Requests the TrGW to bind corresponding IPv4 address(es) and port number(s) from its pool to the received IPv6 address(es) and port number(s) to enable the routing of user plane traffic from the IPv4 SIP network through the TrGW.

When the IMS-ALG has received the requested information from the TrGW the IMS-ALG shall include the IPv4 address(es) and port number(s) in a new offer, which shall be sent to the IPv4 network. The IMS-ALG shall create a SIP message in accordance with the rules for the IMS_ALG described in TS 24.229 [1] with the following clarification:

- The IPv4 address(es) and port number(s) shall replace the IPv6 address(es) and port number(s) in the SDP.
- The IMS-ALG shall create a Record-Route header containing its own SIP URI.

9.1.1.2 Receipt of the first SDP answer

At the receipt of the first SDP answer from the IPv4 network the IMS-ALG:

- Provides to the TrGW the IPv4 address(es) and port number(s) as received in the c-line(s) and m-line(s) in the SDP, and
- Requests the TrGW to bind corresponding IPv6 address(es) and port number(s) from its pool to the received IPv4 address(es) and port number(s) to enable the routing of user plane traffic towards the IPv4 SIP network through the TrGW.

When the IMS-ALG has received the requested information, the IMS-ALG shall send an SDP answer to the IPv6 network. The IMS-ALG shall create the SIP message in accordance with the rules for the IMS ALG described in 3GPP TS 24.229 [1] with the following clarification:

- The IPv6 address(es) and port number(s) shall replace the received IPv4 address(es) and port number(s) in the SDP.

9.1.2 Terminating Session set-up from IPv4 SIP network

9.1.2.1 Receipt of an SDP offer

At the receipt of the first SDP offer the IMS-ALG:

- Provides to the TrGW the IPv4 address(es) and port number(s) as received in the c-lin(es) and m-lin(es) in the SDP, and
- Requests the TrGW to bind corresponding IPv6 address(es) and port number(s) from its pool to the received IPv4 address(es) and port number(s) to enable the routing of user plane traffic towards the IPv4 SIP network through the TrGW.

When the IMS-ALG has received the requested information from the TrGW the IMS-ALG shall send an SDP offer to the IPv6 network. The IMS-ALG shall create a SIP message in accordance with the rules for the IMS ALG described in 3GPP TS 24.229 [1] with the following clarifications:

- The IPv6 address(es) and port number(s) shall replace the received IPv4 address(es) and port number(s) in the SDP.
- The IMS-ALG shall create a Record-Route header containing its own SIP URI if the SIP message is a request.

9.1.2.2 Receipt of SDP answer

At the receipt of a SDP answer from the IPv6 network the IMS-ALG:

- Provides to the TrGW the IPv6 address(es) and port number(s) as received in the c-line(s) and m-line(s) in the SDP.
- Requests the TrGW to bind corresponding IPv4 address(es) and port number(s) from its pool with the received IPv6 address(es) and port number(s) to enable the routing of user plane traffic from the IPv4 SIP network through the TrGW.

When the IMS-ALG has received the requested information, the IMS-ALG shall send a SDP answer to the IPv4 network. The IMS-ALG shall create the SIP message in accordance with the rules for the IMS ALG described in 3GPP TS 24.229 [1] with the following clarification:

- The IPv4 address(es) and port number(s) shall replace the received IPv6 address(es) and port number(s) in the SDP.

9.1.3 Change of connection information

After the dialog is established it is possible for both ends of the session to change the connection data for the session. When the IMS-ALG/TrGW receives a SDP offer/answer where port number(s) or IP address(es) is included., there are four different possibilities:

- 1) IP address(es) or/and port number(s) have been added. In this case additional binding(s) shall be provided by the IMS-ALG/TrGW as detailed for the first SDP offer in the Clauses above;
- 2) IP address(es) or/and port number(s) have been deleted. In this case binding(s) shall be made free by the IMS-ALG/TrGW;
- 3) IP address(es) and port number(s) have been reassigned of the users. In this case the binding(s) shall reflect the reassignment;
- 4) No change has been made to the IP address(es) and port number(s). In this case no change shall be made to the existing binding(s).

9.1.4 Release of the session

At the receipt of BYE, CANCEL request or non 200 final responses the IMS-ALG shall release the session and request the TrGW to release the bindings established for the session.

9.2 User plane transport

9.2.1 Payload transport

The TrGW shall use the established bindings described above to transport the messages between the IPv6 network and IPv4 network in the following way.

At the receipt of a payload message the TrGW shall:

- Replace the received IPv4 address(es) and port number(s) in the payload message with the corresponding IPv6 address(es) and port number(s).
- Replace the received IPv6 address(es) and port number(s) in the payload message with the corresponding IPv4 address(es) and port number(s).

9.2.2 IP header interworking

9.2.2.1 IPv4 to IPv6

When the TrGW receives an IPv4 message the following codings shall be set in the IPv6 headers of the message sent to the IPv6 network.

- If the DF bit is set and the packet is not a fragment (i.e., the MF flag is not set and the Fragment Offset is zero) The IPv6 headers shall be set as described in Table 1;
- If the DF bit is not set or the packet is a fragment the IPv6 headers shall be set as described in Table 2.

IPv6 field	Value
Version	6
Traffic Class:	The default behaviour is that the value of the IPv6 field Traffic Class field is the value of the IPv4 Type Of Service field (all 8 bits are copied). An implementation of a TrGW should also provide the ability to ignore the value of the IPv4 Type of Service and always set the IPv6 traffic class field to zero.
Flow label	The Ipv6 Flow Label Field is set to 0 (all zero bits)
Payload Length	The IPv6 Payload Length field value is the IPv4 Total length field value minus the size of the IPv4 header and IPv4 options field length, if present.
Next Header	The Ipv6 Next Header value is copied from IPv4 Protocol field
Hop Limit:	The IPv6 Hop Limit value is The value of IPv4 field Time To Live minus 1
Source Address	Shall be handled as the addresses of the payload message as described in subclause 9.2.1.
Destination Address	Shall be handled as the addresses of the payload message as described in subclause 9.2.1.

Table 1: Derivation of IPv6 Header from IPv4 header (no fragmentation)

IPv6 field	Value
Version	6
Traffic Class:	The default behaviour is that the value of the IPv6 field Traffic Class field is the value of the IPv4 Type Of Service field (all 8 bits are copied). An implementation of a TrGW should also provide the ability to ignore the value of the IPv4 Type of Service and always set the IPv6 traffic class field to zero.
Flow label	The Ipv6 Flow Label Field is set to 0 (all zero bits)
Payload Length	The IPv6 Payload Length field value is the IPv4 Total length field value plus 8 for the fragment header minus the size of the IPv4 header and IPv4 options field length, if present.

Next Header	The IPv6 Next header field is set to Fragment header (44).
Hop Limit:	The IPv6 Hop Limit value is The value of IPv4 field Time To Live minus 1
Source Address	Shall be handled as the addresses of the payload message as described in subclause 9.2.1.
Destination Address	Shall be handled as the addresses of the payload message as described in subclause 9.2.1.
Fragments headers a) next header b) fragment Offset c) More fragment bit d) Identification	Copied from IPv4 Protocol field Copied from the IPv4 Fragment offset field Copied from the value of the more fragment bit in the IPv4 flags field The low-order 16 bits copied from IPv4 Identification field. The high-order 16 bits set to zero.

Table 2: Derivation of IPv6 Header from IPv4 Header (fragmentation)

9.2.2.2 Abnormal cases

If IPv4 options are present in the IPv4 packet, they should be ignored i.e., there is no attempt to translate them. However, if an unexpired source route option is present then the packet shall instead be discarded, and an ICMPv4 "destination unreachable/source route failed" Type 3/Code 5 error message shall be returned to the sender as defined in IETF RFC 792 [16]

When a translator receives the first fragment of a fragmented UDP IPv4 packet and the checksum field is zero the translator should drop the packet and generate a system management event specifying at least the IP addresses and port numbers in the packet. When it receives fragments other than the first it should silently drop the packet since there is no port information to log.

When a translator receives an unfragmented UDP IPv4 packet and the checksum field is zero the translator shall compute the missing UDP checksum as part of translating the packet. Also, the translator should maintain a counter of how many UDP checksums are generated in this manner.

9.2.2.3 IPv6 to IPv4

When the TrGW receives an IPv6 message the following codings shall be set in the IPv4 headers of the message sent to the IPv4 network.

- If there is no IPv6 fragment header the IPv4 header fields shall be set as described in Table 3;
- If there is no IPv6 fragment header the IPv4 header fields shall be set as described in Table 3;

IPv4 field	Value
Version	4
Internet header length	5 (No IPv4 options)
Type of Service	The default behaviour is that the value of the IPv4 field Type of service field is the value of the IPv6 Traffic class field (all 8 bits are copied). An implementation of a TrGW should also provide the ability to ignore the value of the IPv6 Traffic Class and always set the IPv4 Type of Service field to zero.
Total length	The IPv4 Total Length field value is the IPv6 Payload length value plus the size of the IPv4 headers.
Identification	All bits are set to zero
Flags	The more fragment flag is set to zero. The Don't fragment flag is set to one.
Fragment offset	Set to zero
Time to live (TTL)	The value of the field shall be set to the received IPv6 Hop Limit field value minus 1.
Protocol	The IPv4 field Protocol shall be set to the value of IPv6 field The next header value.
Header checksum	Computed once the IPv4 header has been created.
Source Address	Shall be handled as the addresses of the payload message as described in subclause 9.2.1.
Destination Address	Shall be handled as the addresses of the payload message as described in subclause 9.2.1.

Table 3: Derivation of IPv4 Header from IPv6 Header (no fragmentation)

IPv4 field	Value
Version	4
Internet header length	5 (No IPv4 options)
Type of Service and Precedence:	The default behaviour is that the value of the IPv4 field Type of service field is the value of the IPv6 Traffic class field (all 8 bits are copied). An implementation of a TrGW should also provide the ability to ignore the value of the IPv6 Traffic Class and always set the IPv4 Type of Service field to zero.
Total length	The IPv4 Total Length field value is the IPv6 Payload length value plus the size of the IPv4 headers minus 8 for the Fragment header,

Identification	The IPv4 Identification field is copied from the low-order 16-bits in the IPv6 identification field in the IPv6 Fragment header.
Flags	The IPv4 the More Fragments flag is copied from the IPv6 M flag in the IPv6 Fragment header the IPv4 he Don't Fragments flag is set to zero allowing this packet to be fragmented by IPv4 routers.
Time to live (TTL)	The value of the field shall be set to the received IPv6 Hop Limit field value minus 1.
Protocol	The IPv4 field Protocol shall be set to the value of IPv6 field The next header value.
Header checksum	Computed once the IPv4 header has been created
Source Address	Shall be handled as the addresses of the payload message as described in subclause 9.2.1.
Destination Address	Shall be handled as the addresses of the payload message as described in subclause 9.2.1.

Table 4: Derivation of IPv4 Header from IPv6 Header (fragmentation)

9.2.2.4 Abnormal cases

If any of an IPv6 hop-by-hop options header, destination options header, or routing header with the Segments Left field equal to zero are present in the IPv6 packet, they are ignored i.e., there is no attempt to translate them. However, the Total Length field and the Protocol field shall be adjusted to "skip" these extension headers.

If a routing header with a non-zero Segments Left field is present then the packet shall be translated, and an ICMPv6 "parameter problem/ erroneous header field encountered" Type 4/Code 0 error message as defined in IETF RFC 2463 [17], with the Pointer field indicating the first byte of the Segments Left field should be returned to the sender.

9.2.3 Fragmentation

If the DF flag is not set and the IPv4 packet will result in an IPv6 packet larger than 1280 bytes the TrGW shall prior to transferring it in the IPv6 network:

- Add the fragment header to the message
- Fragment the IPv4 packets so that their length, excluding the IPv4 header, is at most 1232 bytes (1280 minus 40 for the IPv6 header and 8 for the Fragment header).

9.2.4 Abnormal cases

As a part of decrementing the Time To Live /Hop Limit value and the TrGW discovers that the zero value is reached the TrGW shall send an ICMPv4/ICMPv6 message with the error "time to live exceeded in transit" type 11 code 0 as defined in IETF RFC 792 [16] and "hop limit exceeded in transit" type 3 code 0 as defined in IETF RFC 2463 [17].

Annex A (informative): Codecs used for Conversational Services

Codecs used for Conversational Services For codecs for conversational services in the PS domain are defined according to 3GPP TS 26.235 [6]. These include:

- Narrowband speech: The support of the AMR codec is mandated.
- For wideband speech: The support of the AMR-WB codec is mandated
- For video: The support of the H.263 profile 0 level 10 v1 is mandated, and the support of MPEG4 visual sp @ level 0 and ITU-T Recommendation H.263 [14] profile 3 level 10 are optional.

In non-3GPP SIP networks there are no mandatory codecs. However, the following codecs are of interest:

- Narrowband speech: ITU-T Recommendations G.723.1 [15], G.729 [16] and G.711 [17] are known to be commonly deployed.
- Video codecs: ITU-T Recommendation H.263 [14] and MPEG4 are expected to be used.

Annex B (informative): Change history

Change history							
Date	TSG #	TSG Doc.	CR	Rev	Subject/Comment	Old	New
2001-02					Version 0.0.0 Presented to CN3 #16 - Sophia Antipolis - Initial Proposal - TS 29.162 number allocated by MCC		0.0.0
2001-05					Tdocs N3-010226 and N3-010200 agreed at CN3#17 - Rio Grande, Puerto Rico		0.1.0
2001-10					Tdoc N3-010331 agreed at CN3#18 - Dresden, Germany	0.1.0	0.2.0
2001-10					Revised TS based on decision within CN3#19 to reduce the scope of Work Item - as proposed in Tdoc N3-010425. Clean version based on changes agreed in N3-010479 at Cn3#19 -Brighton, UK.	0.2.0	0.3.0
2001-11					Added informative Annex A about interworking between IPv4 and IPv6, as agreed in Cn3#20 Cancun.	0.3.0	0.4.0
2002-01					Included N3-020094, N3-020104, and tidied editors notes.	0.4.0	0.5.0
2002-02					Editorial changes agreed in CN3#21, Sophia Antipolis.	0.5.0	0.6.0
2002-02					DAB, MCC some minor editorials	0.6.0	0.6.1
2002-03					Presented as v1.0.0 to TSG#15 for information	0.6.1	1.0.0
2004-08					Changes e.g. on IPv4-IPv6 interworking agreed in CN3#33, Sophia	1.0.0	1.1.0
2004-09					Editorial corrections made to ensure alignment with 3GPP drafting rules	1.1.0	1.1.1
2004-10					Changes e.g. on IPv4-IPv6 interworking agreed in CN3#33bis, Sophia	1.1.1	1.2.0

Editor: Nigel Holland (nigel.holland@o2.com)

3GPP TS 29.162 V1.~~2~~3.0 (2004-~~10~~11)

Technical Specification

3rd Generation Partnership Project; Technical Specification Group Core Network; Interworking between the IM CN subsystem and IP networks (Release 6)



The present document has been developed within the 3rd Generation Partnership Project (3GPPTM) and may be further elaborated for the purposes of 3GPP.

The present document has not been subject to any approval process by the 3GPP Organizational Partners and shall not be implemented. This Specification is provided for future development work within 3GPP only. The Organizational Partners accept no liability for any use of this Specification. Specifications and reports for implementation of the 3GPPTM system should be obtained via the 3GPP Organizational Partners' Publications Offices.

Keywords

3GPP

Postal address

3GPP support office address

650 Route des Lucioles - Sophia Antipolis
Valbonne - FRANCE
Tel.: +33 4 92 94 42 00 Fax: +33 4 93 65 47 16

Internet

<http://www.3gpp.org>

Copyright Notification

No part may be reproduced except as authorized by written permission.
The copyright and the foregoing restriction extend to reproduction in all media.

© 2004, 3GPP Organizational Partners (ARIB, ATIS, CCSA, ETSI, TTA, TTC).
All rights reserved.

Contents

Foreword.....	4
1 Scope	5
2 References	5
3 Definitions, symbols and abbreviations.....	6
3.1 Definitions	6
3.2 Symbols	6
3.3 Abbreviations	6
4 General	7
4.1 General interworking overview	7
4.2 Interworking scenarios	7
4.2.1 UE with 3GPP SIP profile capability connecting to an external SIP device.....	7
5 Network characteristics	8
5.1 Key characteristics of IP Multimedia Networks.....	8
5.2 Key characteristics of UMTS IM CN Subsystem.....	8
6 Interworking with IP networks	8
6.1 Interworking Reference Model for control plane interworking and user plane interworking	8
6.1.1 Interworking Functional Entities.....	9
6.1.1.1 S-CSCF	9
6.1.1.2 MRFP	9
6.1.1.3 MRFC.....	9
6.2 Control plane interworking model.....	9
6.2.1 IM CN Subsystem originated calls	9
6.2.2 IM CN Subsystem terminated calls.....	9
6.3 User plane interworking model	9
6.4 IP version interworking model	10
6.4.1 Interworking functional entities	10
6.4.1.1 IMS-ALG	10
6.4.1.2 TrGW	10
7 Control plane interworking.....	10
7.1 SIP with 3GPP Profile to Standard SIP Interworking	10
8 User Plane Interworking	11
8.1 Overview	11
8.2 Transparent User Plane.....	11
8.3 Non Transparent User Plane.....	11
9 IP Version Interworking at the IMS-ALG/TrGW	11
9.1 Control plane interworking.....	11
9.1.1 Originating Session Set-up to IPv4 SIP network	11
9.1.1.1 Receipt of the first SDP offer	11
9.1.1.2 Receipt of the first SDP answer.....	11
9.1.2 Terminating Session set-up from IPv4 SIP network	12
9.1.2.1 Receipt of an SDP offer.....	12
9.1.2.2 Receipt of SDP answer.....	12
9.1.3 Change of connection information.....	12
9.1.4 Release of the session	12
9.2 User plane transport.....	13
Annex A (informative): Codecs used for Conversational Services.....	14
Annex B (informative): Change history.....	15

Foreword

This Technical Specification has been produced by the 3rd Generation Partnership Project (3GPP).

The contents of the present document are subject to continuing work within the TSG and may change following formal TSG approval. Should the TSG modify the contents of the present document, it will be re-released by the TSG with an identifying change of release date and an increase in version number as follows:

Version x.y.z

where:

- x the first digit:
 - 1 presented to TSG for information;
 - 2 presented to TSG for approval;
 - 3 or greater indicates TSG approved document under change control.
- y the second digit is incremented for all changes of substance, i.e. technical enhancements, corrections, updates, etc.
- z the third digit is incremented when editorial only changes have been incorporated in the document.

1 Scope

The IM CN subsystem interworks with the external IP networks through the Mb reference point.

This document details the interworking between the IM CN subsystem and external IP networks for IM service support. It addresses the issues of control plane interworking, user plane interworking and IP version interworking.

~~The document specifies the control plane interworking between a standard SIP as specified in RFC 3261 [2] and the 3GPP profile as specified in 3GPP TS 24.229 [1].~~

The IP version Interworking, between IP version 4 RFC 791 [9] and IP version 6 RFC 1883 [10] detailed in terms of the processes and protocol mappings required in order to support both mobile originated and terminated calls.

~~Other areas addressed encompass mapping of bearer capabilities and QoS information.~~

2 References

The following documents contain provisions which, through reference in this text, constitute provisions of the present document.

- References are either specific (identified by date of publication, edition number, version number, etc.) or non-specific.
- For a specific reference, subsequent revisions do not apply.
- For a non-specific reference, the latest version applies. In the case of a reference to a 3GPP document (including a GSM document), a non-specific reference implicitly refers to the latest version of that document *in the same Release as the present document*.

[1] 3GPP TS 24.229: "Internet Protocol (IP) multimedia call control protocol based on Session Initiation Protocol (SIP) and Session Description Protocol (SDP); Stage 3".

[2] IETF RFC 3261: "SIP: Session Initiation Protocol".

[3] 3GPP TS 23.221: "Architectural requirements".

[4] 3GPP TS 29.061: "Interworking between the Public Land Mobile Network (PLMN) supporting packet based services and Packet Data Networks (PDN)".

[5] 3GPP TS 23.002: "Network architecture".

[6] 3GPP TS 26.235: "Packet switched conversational multimedia applications; Default codecs".

[7] 3GPP TR 21.905: "Vocabulary for 3GPP Specifications".

[8] 3GPP TS 23.228: "IP Multimedia Subsystem (IMS); Stage 2".

[9] IETF RFC 791: "Internet Protocol".

[10] IETF RFC 2460: "Internet Protocol, Version 6 (IPv6) Specification".

[11] IETF RFC 2766: "Network Address Translation - Protocol Translation (NAT-PT)".

[12] IETF RFC 2663: "IP Network Address Translator (NAT) Terminology and Considerations".

[13] 3GPP TR 29.962 [version 6.1.0](#): "Signalling interworking between the 3GPP profile of the Session Initiation Protocol (SIP) and non-3GPP SIP usage".

[14] ITU-T Recommendation H.263: "Video coding for low bit rate communication".

[15] ITU-T Recommendation G.723.1: "Dual rate speech coder for multimedia communications transmitting at 5.3 and 6.3 kbit/s".

- [16] ITU-T Recommendation G.729: "Coding of speech at 8 kbit/s using conjugate-structure algebraic-code-excited linear-prediction (CS-ACELP)".
- [17] ITU-T Recommendation G.711: "Pulse code modulation (PCM) of voice frequencies".
- [18] IETF RFC 792: "Internet Control Message Protocol"
- [19] IETF RFC 2463: "Internet Control Message Protocol (ICMPv6) for the Internet Protocol Version 6"
- [20] IETF RFC 2765: "Stateless IP/ICMP Translation Algorithm (SITT)"

3 Definitions, symbols and abbreviations

3.1 Definitions

For the purposes of the present document, the terms and definitions given in 3GPP TR 21.905 [7] and the following apply:

IM CN subsystem: (IP Multimedia CN subsystem) comprises of all CN elements for the provision of IP multimedia applications over IP multimedia sessions

IP multimedia session: set of multimedia senders and receivers and the data streams flowing from senders to receivers IP multimedia sessions are supported by the IP multimedia CN Subsystem and are enabled by IP connectivity bearers (e.g. GPRS as a bearer). A user may invoke concurrent IP multimedia sessions.

3.2 Symbols

Void.

3.3 Abbreviations

For the purposes of the present document, the following abbreviations apply:

CSCF	Call Session Control Function
GTP	GPRS Tunnelling Protocol
IETF STD	Internet Engineering Task Force STandard
IM	IP Multimedia
IMS	IP Multimedia Subsystem
IMS-ALG	IMS - Application Level Gateway
IP	Internet Protocol
IPv4	IP version 4
IPv6	IP version 6
LAN	Local Area Network
MEGACO	MEdia GAteway COntrol
MRFC	Multimedia Resource Function Controller
MRFP	Multimedia Resource Function Processor
NA (P) T-PT	Network Address (Port-Multiplexing) Translation-Protocol Translation
PDN	Packet Data Network
QoS	Quality of Service
S-CSCF	Serving-CSCF
SIP UA	SIP User Agent
SIP	Session Initiation Protocol
TrGW	Translation GateWay
UE	User Equipment
WAN	Wide Area Network

4 General

4.1 General interworking overview

The IM CN Subsystem ~~shall~~ interworks with SIP RFC 3261 [2] based IP Multimedia networks. These IP Multimedia networks include:

- SIP User Agents (UAs);
- SIP Servers.

As such, the IM CN Subsystem has to be able to interwork to all of these above functional entities in the IP multimedia network, as there is a possibility that they all may be involved in an IM session. The general interworking model is shown in figure 1. The SIP based Multimedia networks may use IP version 4 RFC 791 [9] or IP version 6 RFC 1883 [10].

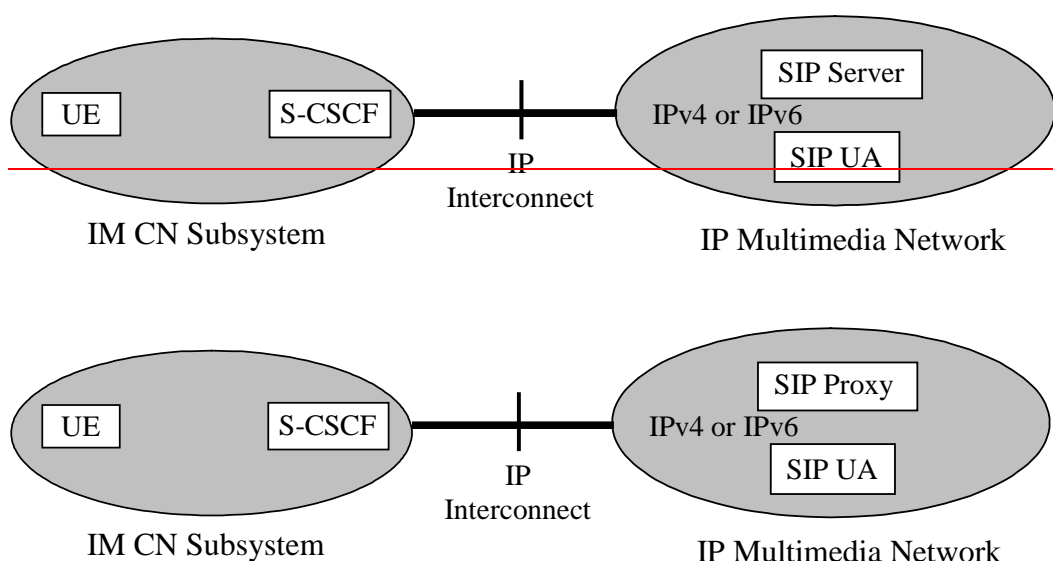

Figure 1: Interworking Model for IM CN Subsystem to IP Multimedia Network

The UE ~~shall~~ uses the CSCF in order to communicate with the external IP multimedia network entities.

~~It shall be possible for the~~ If no IP version interworking is required, the CSCF ~~to~~ can communicate with SIP UAs in an external IP multimedia network directly.

~~It shall be possible for the~~ If no IP version interworking is required, the CSCF ~~to~~ can also communicate with SIP Servers proxies in an external IP multimedia network directly, which in turn can then communicate with SIP UAs.

To provide the IP version interworking the functions of an IMS-ALG and a TrGW may be inserted between the CSCF and external IP Multimedia Network by configuration, used. The IMS-ALG and the TrGW may be implemented as a part of other physical entities in the IMS.

NOTE: Other methods to provide IP version interworking are for further study.

4.2 Interworking scenarios

3GPP specifications design the IM CN subsystem elements and interfaces to exclusively support IPv6. 3GPP TS 23.221 [3] details the interoperability scenarios that an UE may experience when interworking with an external PDN. All of these IP transport layer interworking scenarios can apply to the application layer interworking scenarios detailed in clause 4.2.1.

4.2.1 UE with 3GPP SIP profile capability connecting to an external SIP device

The procedures used by an UE with 3GPP SIP profile to connect to an external SIP device, [which may lack 3GPP SIP profile capabilities](#), ~~are~~ [have been](#) analysed in [Release 6 within](#) 3GPP TR 29.962 [13] and are specified in 3 GPP TS 24.229 [1].

5 Network characteristics

5.1 Key characteristics of IP Multimedia Networks

The Internet is a conglomeration of networks utilising a common set of protocols. IP protocols are defined in the relevant IETF RFCs. The networks topologies may be based on LANs (e.g. Ethernet), Point-to-Point leased lines, PSTN, ISDN, X.25 or WANs using switched technology (e.g. SMDS, ATM).

IP multimedia networks provide the ability for users to invoke IP multimedia applications in order to send and receive (where applicable) voice and data communications. One protocol used to manage IP multimedia sessions is the Session Initiation Protocol (SIP) (RFC 3261 [2]).

5.2 Key characteristics of UMTS IM CN Subsystem

The UMTS IM CN subsystem uses the SIP protocol to manage IP multimedia sessions, and uses IP as the transport mechanism for both SIP session signalling and media transport.

The UMTS IM CN subsystem shall support interworking with existing fixed and mobile voice and IP data networks, including PSTN, ISDN, Mobile and Internet.

~~6 Interworking with IP networks~~

~~6.1 Interworking Reference Model for control plane interworking and user plane interworking~~

Figure 2 details the reference architecture required to support interworking between the IM CN subsystem and IP networks for IM services. [Figure 3 details the reference architecture required to support interworking between the IMS and IP SIP networks supporting IP version 4.](#)

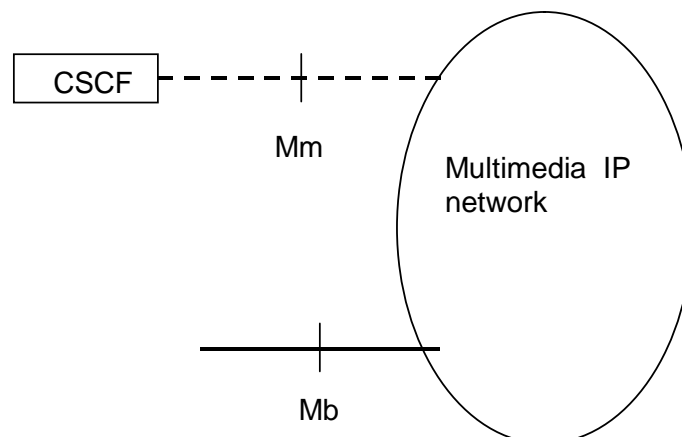

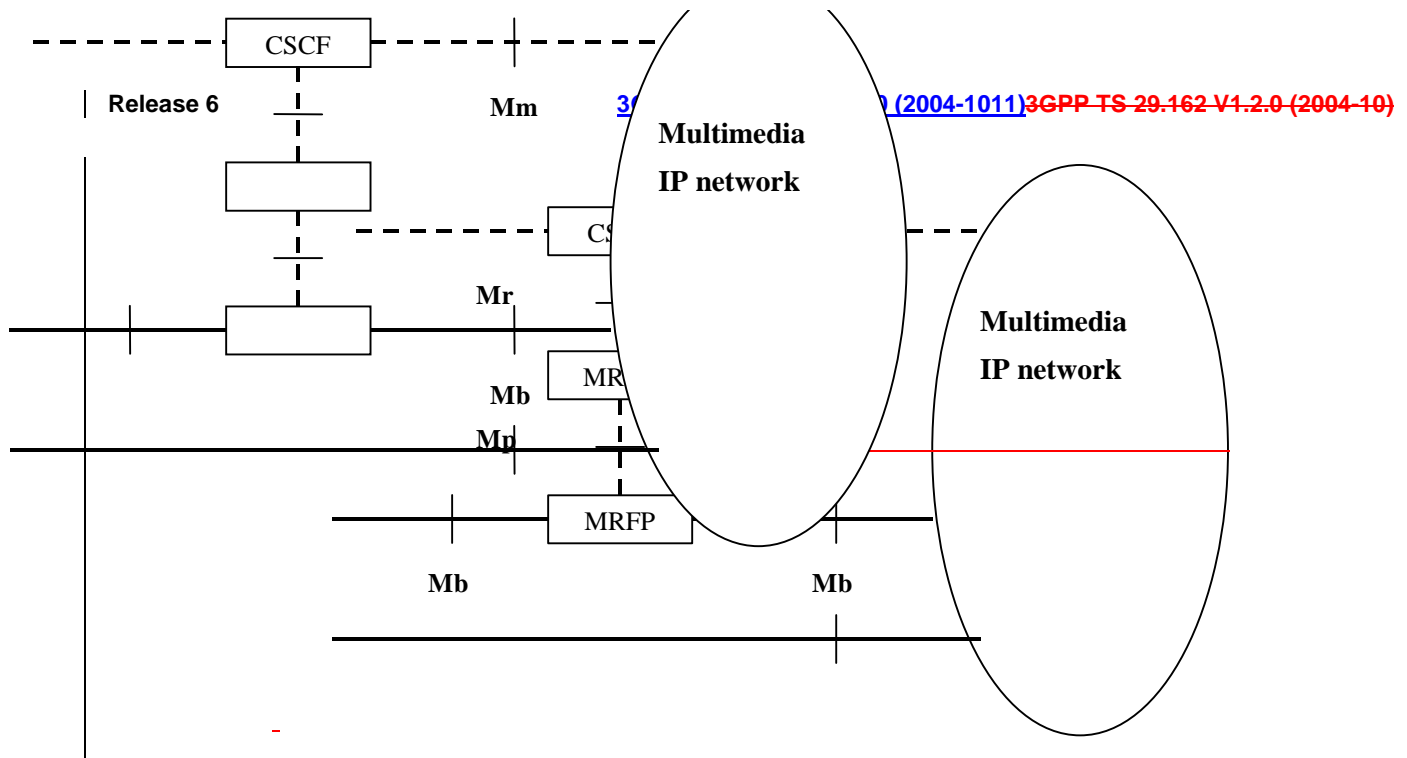

NOTE: Multimedia IP networks may be connected via the Mb interface to various network entities, such as an UE (via an GTP Tunnel reaching to the GGSN), an MRFP, or an application server.

Figure 2: IM CN Subsystem to IP network interworking ~~reference~~. Architecture without IP version interworking

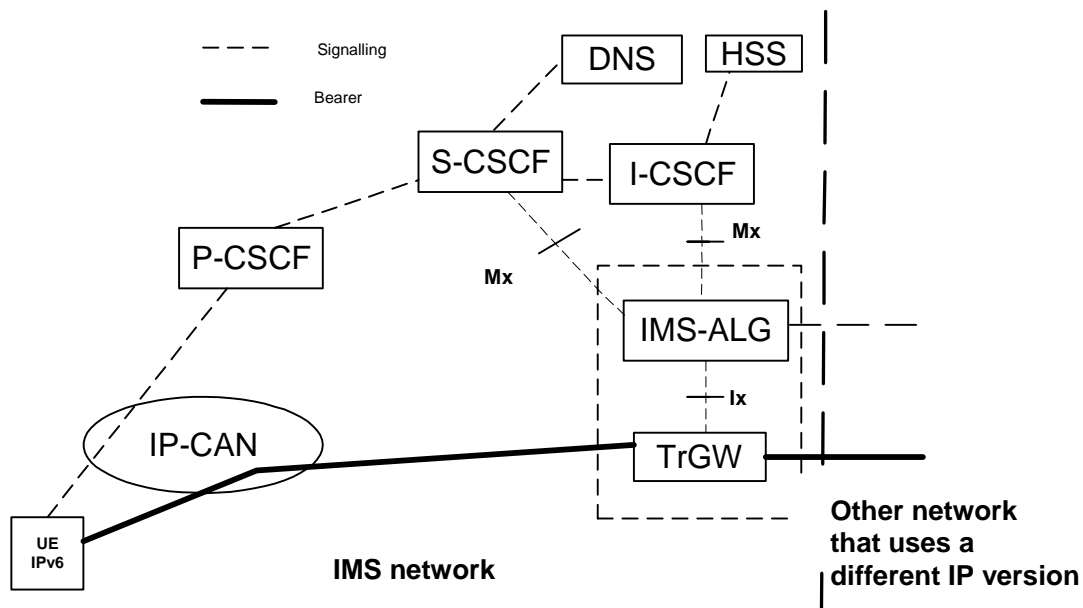

Figure 3: Model for IP version interworking

~~Protocol for Mm reference point:~~ The ~~single~~ call control protocol applied to the Mm interface between CSCF and external IP networks ~~will be~~ is SIP, RFC 3261 [2], as detailed in 3GPP TS 24.229 [1]. SIP extension packages mandated by 3GPP are possibly not supported.

~~Protocol for Mb reference point:~~ This interface is defined in 3GPP TS 23.002 [5] and is IP based. Further information is provided in 3GPP TS 29.061 [4] and 3GPP TS 26.235 [6].

Mx reference point: The protocol applied at the Mx reference point is not specified within this release of the specification.

Ix reference point: The protocol applied at the Ix reference point is not specified within this release of the specification.

~~Protocol for Mr:~~ This interface is detailed in 3GPP TS 24.229 [1]. The protocol is not specified within this release of the specification.

~~Protocol for Mp:~~ This interface is defined in 3GPP TS 23.002 [5]. The protocol is not specified within this release of the specification.

6.1.4 Interworking Functional Entities

6.1.1.4 S-CSCF

This entity provides ~~the~~ control plane functionality ~~between to connect entities~~ following the 3GPP profile of SIP, ~~SIP with 3GPP~~ TS 24.229 [1], and external SIP entities following RFC 3261 [2].

6.1.2 IMS-ALG

An IMS ALG provides the application level translation function for SIP and SDP in order to communicate between IPv6 and IPv4 SIP applications. The IMS-ALG is a SIP Back-to-Back User Agent.

6.1.3 TrGW

The TrGW is a NAT-PT/NAPT-PT, which uses a pool of globally unique IPv4 addresses for assignment to IPv6 nodes on a dynamic basis as sessions are initiated across the IP version boundaries. NAT-PT binds addresses in IPv6 network with addresses in IPv4 network and vice versa to provide transparent routing between the two IP domain without requiring any changes to end points. NAPT-PT provides additional translation of transport identifier (TCP and UDP port numbers). More detailed information on the NAT-PT/NAPT-PT is given in RFC 2766 [11] and RFC 2663 [12].

6.1.1.2 MRFP

~~This entity may be used to provide user plane transcoding within the IM-CN subsystem.~~

6.1.1.3 MRFC

~~This entity controls the MRFP via the Mp interface.~~

6.2 Control plane interworking model

6.2.1 IM-CN Subsystem originated calls

~~IMS sessions, which originate in the IM-CN subsystem, shall be required to interwork to standard SIP RFC 3261 [2] based IP Multimedia network domains at the control plane level within the UMTS IM Subsystem domain.~~

- ~~—For sessions terminating in SIP based IP networks, then control plane interworking shall be supported via the Mm reference interface (S-CSCF to external IP multimedia networks).~~

6.2.2 IM-CN Subsystem terminated calls

~~IMS session, which terminate in the IM-CN Subsystem, shall be required to interwork to standard SIP RFC 3261 [2] based IP Multimedia network domains at the control plane level within the UMTS IM Subsystem domain.~~

- ~~—For sessions originating in SIP based IP networks, then control plane interworking shall be supported via the Mm reference interface (S-CSCF to external IP multimedia networks).~~

6.3 User plane interworking model

~~The Mb interface is used to provide the user plane within the IM-CN subsystem and towards external IP Multimedia network domains.~~

A MRFP may be inserted in the user plane. The MRFP provides support for bearer related services such as multi party sessions, announcements to a user or transcoding.

6.4 IP version interworking model

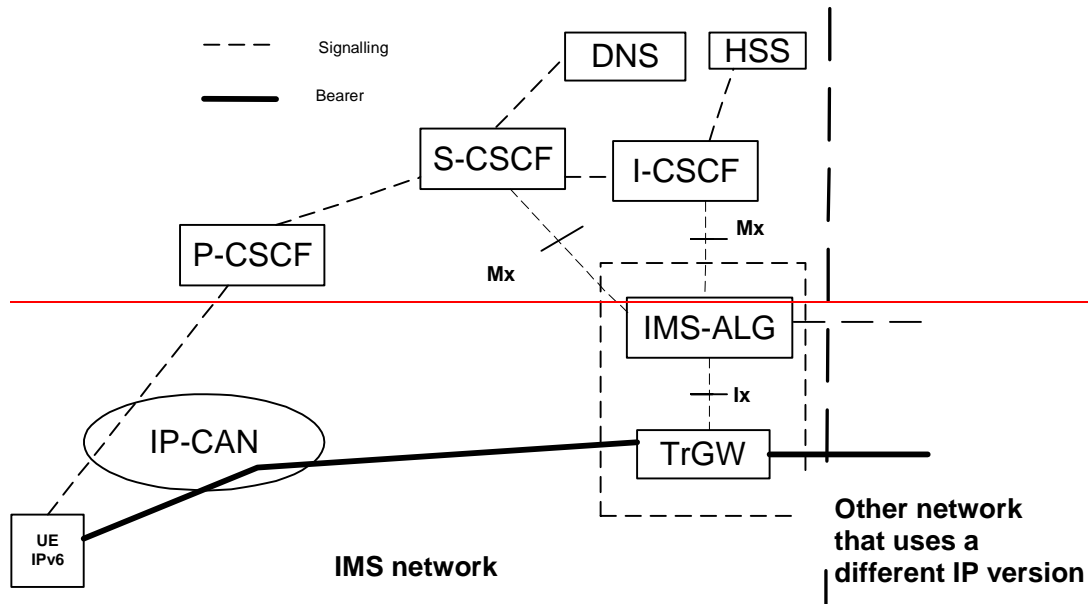

Figure 3: Model for IP version interworking

Figure 3 details the reference architecture required to support interworking between the IMS and IP SIP networks supporting IP version 4.

Mx reference point: The Mx reference point is not specified within this release of the specification.

Ix reference point: The Ix reference point is not specified within this release of the specification.

6.4.1 Interworking functional entities

6.4.1.1 IMS-ALG

An IMS ALG provides the application level translation function for SIP and SDP in order to communicate between IPv6 and IPv4 SIP applications. The IMS ALG is a SIP Back to Back User Agent.

6.4.1.2 TrGW

The TrGW is a NAT-PT/NAPT-PT, which uses a pool of globally unique IPv4 addresses for assignment to IPv6 nodes on a dynamic basis as sessions are initiated across the IP version boundaries. NAT-PT binds addresses in IPv6 network with addresses in IPv4 network and vice versa to provide transparent routing between the two IP domain without requiring any changes to end-points. NAPT-PT provides additional translation of transport identifier (TCP and UDP port numbers). More detailed information on the NAT-PT/NAPT-PT is given in RFC 2766 [11] and RFC 2663 [12].

7 Control plane interworking

7.1 SIP with 3GPP Profile to Standard SIP Interworking

3GPP TS 24.229 [1] defines the procedures, which allow a 3GPP-IMS UE to connect to a standard SIP terminal.

8 User Plane Interworking

8.1 Overview

The present specification addresses user plane interworking between codec types used for either speech or video. Codecs used for conversational services in the PS domain are as defined in 3GPP TS 26.235 [6]. Codecs of particular interest are described in annex A

8.2 Transparent User Plane

The user plane may be transported through the IM CN subsystem without being processed by any IM CN subsystem entity.

8.3 Non Transparent User Plane

The MRFP may provide transcoding of the user plane if a codec mismatch occurs. [It is not specified in the present release how the MRFP is inserted and controlled to provide transcoding.](#)

9 IP Version Interworking at the IMS-ALG/TrGW

9.1 Control plane interworking

9.1.1 Originating Session Set-up to IPv4 SIP network

9.1.1.1 Receipt of the first SDP offer

At the receipt of the first SDP offer the IMS-ALG:

- Provides to the TrGW the IPv6 address(es) and port number(s) as received in the c-line(s) and m-line(s) in the SDP, ~~and-~~
- Requests the TrGW to bind corresponding IPv4 address(es) ~~from its pool~~ and port number(s) [from its pool](#) to the received IPv6 address(es) and port number(s) to enable the routing of user plane traffic [from the IPv4 SIP network](#) through the TrGW.

When the IMS-ALG has received the requested information from the TrGW the IMS-ALG shall include the IPv4 address(es) and port number(s) in a new offer, which shall be sent to the IPv4 network. The IMS-ALG shall create a SIP message in accordance with the rules [for the IMS ALG of a Back-to-Back User agent as](#) described in TS 24.229 [1] with the following clarification:

- The IPv4 address(es) and port number(s) shall replace the IPv6 address(es) and port number(s) in the SDP.
- The IMS-ALG shall create a Record-Route header containing its own SIP URI.

9.1.1.2 Receipt of the first SDP answer

At the receipt of the first SDP answer from the IPv4 network the IMS-ALG:

- Provides to the TrGW the IPv4 address(es) and port number(s) as received in the c-line(s) and m-line(s) in the SDP, ~~and~~ [and](#)
- Requests the TrGW to bind ~~the~~ corresponding IPv6 address(es) and port number(s) [from its pool](#) to the received IPv4 address(es) and port number(s) to enable the routing of user plane traffic [towards the IPv4 SIP network](#) through the TrGW.

When the IMS-ALG has received the requested information, the IMS-ALG shall send an SDP answer to the IPv6 network. The IMS-ALG shall create the SIP message in accordance with the rules [for the IMS ALG](#) ~~of a Back-to-Back User agent as~~ described in 3GPP TS 24.229 [1] with the following clarification:

- The IPv6 address(es) and port number(s) shall replace the received IPv4 address(es) and port number(s) in the SDP.

9.1.2 Terminating Session set-up from IPv4 SIP network

9.1.2.1 Receipt of an SDP offer

At the receipt of the first SDP offer the IMS-ALG:

- Provides to the TrGW the IPv4 address(es) and port number(s) as received in the c-lin(es) and m-lin(es) in the SDP, ~~and~~.
- Requests the TrGW to bind ~~the~~ corresponding IPv6 address(es) and port number(s) [from its pool](#) to the received IPv4 address(es) and port number(s) to enable the routing of user plane traffic [towards the IPv4 SIP network](#) through the TrGW.

When the IMS-ALG has received the requested information from the TrGW the IMS-ALG shall send an SDP offer to the IPv6 network. The IMS-ALG shall create a SIP message in accordance with the rules [for the IMS ALG](#) ~~of a Back-to-Back User agent as~~ described in 3GPP TS 24.229 [1] with the following clarification:

- The IPv6 address(es) and port number(s) shall replace the received IPv4 address(es) and port number(s) in the SDP.
- The IMS-ALG shall create a Record-Route header containing its own SIP URI if the SIP message is a request.

9.1.2.2 Receipt of SDP answer

At the receipt of a SDP answer from the IPv6 network the IMS-ALG:

- Provides to the TrGW the IPv6 address(es) and port number(s) as received in the c-line(s) and m-line(s) in the SDP.
- Requests the TrGW to bind ~~the~~ corresponding IPv4 address(es) and port number(s) [from its pool](#) with the received IPv6 address(es) and port number(s) to enable the routing of user plane traffic [from the IPv4 SIP network](#) through the TrGW.

When the IMS-ALG has received the requested information, the IMS-ALG shall send a SDP answer to the IPv4 network. The IMS-ALG shall create the SIP message in accordance with the rules ~~of a Back-to-Back User agent as~~ [for the IMS ALG](#) described in 3GPP TS 24.229 [1] with the following clarification:

- The IPv4 address(es) and port number(s) shall replace the received IPv6 address(es) and port number(s) in the SDP.

9.1.3 Change of connection information

After the dialog is established it is possible for both ends of the session to change the connection data for the session. When the IMS-ALG/TrGW receives a SDP offer/answer where port number(s) or IP address(es) is included, ~~t~~ There are four different possibilities:

- 1) IP address(es) or/and port number(s) have been added. In this case additional binding(s) shall be provided [by the IMS-ALG/TrGW as detailed for the first SDP offer in the Clauses above](#);
- 2) IP address(es) or/and port number(s) have been deleted. In this case binding(s) shall be made free [by the IMS-ALG/TrGW](#);
- 3) IP address(es) and port number(s) have been reassigned of the users. In this case the binding(s) shall reflect the reassignment;

- 4) No change has been made to the IP address(es) and port number(s). In this case no change shall be made to the existing binding(s).

9.1.4 Release of the session

At the receipt of BYE, CANCEL request or non 200 final responses the IMS-ALG shall release the session and request the TrGW to release the bindings established for the session.

9.2 User plane transport

9.2.1 Payload transport

The TrGW shall use the established bindings described above to transport the messages between the IPv6 network and IPv4 network in the following way.

At the receipt of a payload message the TrGW shall:

- Replace the received IPv4 address(es) and port number(s) in the payload message with the corresponding IPv6 address(es) and port number(s).
- Replace the received IPv6 address(es) and port number(s) in the payload message with the corresponding IPv4 address(es) and port number(s).

9.2.2 IP header interworking

9.2.2.1 IPv4 to IPv6

When the TrGW receives an IPv4 message the following codings shall be set in the IPv6 headers of the message sent to the IPv6 network.

- If the DF bit is set and the packet is not a fragment (i.e., the MF flag is not set and the Fragment Offset is zero) The IPv6 headers shall be set as described in Table 1;
- If the DF bit is not set or the packet is a fragment the IPv6 headers shall be set as described in Table 2.

IPv6 field	Value
Version	6
Traffic Class:	The default behaviour is that the value of the IPv6 field Traffic Class field is the value of the IPv4 Type Of Service field (all 8 bits are copied). An implementation of a TrGW should also provide the ability to ignore the value of the IPv4 Type of Service and always set the IPv6 traffic class field to zero.
Flow label	The Ipv6 Flow Label Field is set to 0 (all zero bits)
Payload Length	The IPv6 Payload Length field value is the IPv4 Total length field value minus the size of the IPv4 header and IPv4 options field length, if present.

Next Header	The Ipv6 Next Header value is copied from IPv4 Protocol field
Hop Limit:	The IPv6 Hop Limit value is The value of IPv4 field Time To Live minus 1
Source Address	Shall be handled as the addresses of the payload message as described in subclause 9.2.1.
Destination Address	Shall be handled as the addresses of the payload message as described in subclause 9.2.1.

Table 1: Derivation of IPv6 Header from IPv4 header (no fragmentation)

IPv6 field	Value
Version	6
Traffic Class:	The default behaviour is that the value of the IPv6 field Traffic Class field is the value of the IPv4 Type Of Service field (all 8 bits are copied). An implementation of a TrGW should also provide the ability to ignore the value of the IPv4 Type of Service and always set the IPv6 traffic class field to zero.
Flow label	The Ipv6 Flow Label Field is set to 0 (all zero bits)
Payload Length	The IPv6 Payload Length field value is the IPv4 Total length field value plus 8 for the fragment header minus the size of the IPv4 header and IPv4 options field length, if present.
Next Header	The IPv6 Next header field is set to Fragment header (44).
Hop Limit:	The IPv6 Hop Limit value is The value of IPv4 field Time To Live minus 1
Source Address	Shall be handled as the addresses of the payload message as described in subclause 9.2.1.
Destination Address	Shall be handled as the addresses of the payload message as described in subclause 9.2.1.
Fragments headers a) next header b) fragment Offset c) More fragment bit d) Identification	Copied from IPv4 Protocol field Copied from the IPv4 Fragment offset field Copied from the value of the more fragment bit in the IPv4 flags field The low-order 16 bits copied from IPv4 Identification field. The high-order 16 bits set to zero.

Table 2: Derivation of IPv6 Header from IPv4 Header (fragmentation)

9.2.2.2 Abnormal cases

If IPv4 options are present in the IPv4 packet, they should be ignored i.e., there is no attempt to translate them. However, if an unexpired source route option is present then the packet shall instead be discarded, and an ICMPv4 "destination unreachable/source route failed" Type 3/Code 5 error message shall be returned to the sender as defined in IETF RFC 792 [16]

When a translator receives the first fragment of a fragmented UDP IPv4 packet and the checksum field is zero the translator should drop the packet and generate a system management event specifying at least the IP addresses and port numbers in the packet. When it receives fragments other than the first it should silently drop the packet since there is no port information to log.

When a translator receives an unfragmented UDP IPv4 packet and the checksum field is zero the translator shall compute the missing UDP checksum as part of translating the packet. Also, the translator should maintain a counter of how many UDP checksums are generated in this manner.

9.2.2.3 IPv6 to IPv4

When the TrGW receives an IPv6 message the following codings shall be set in the IPv4 headers of the message sent to the IPv4 network.

- If there is no IPv6 fragment header the IPv4 header fields shall be set as described in Table 3;
- If there is no IPv6 fragment header the IPv4 header fields shall be set as described in Table 3;

IPv4 field	Value
Version	4
Internet header length	5 (No IPv4 options)
Type of Service	The default behaviour is that the value of the IPv4 field Type of service field is the value of the IPv6 Traffic class field (all 8 bits are copied). An implementation of a TrGW should also provide the ability to ignore the value of the IPv6 Traffic Class and always set the IPv4 Type of Service field to zero.
Total length	The IPv4 Total Length field value is the IPv6 Payload length value plus the size of the IPv4 headers.
Identification	All bits are set to zero
Flags	The more fragment flag is set to zero. The Don't fragment flag is set to one.
Fragment offset	Set to zero
Time to live (TTL)	The value of the field shall be set to the received IPv6 Hop Limit field value minus 1.
Protocol	The IPv4 field Protocol shall be set to the value of IPv6 field The next header value.
Header checksum	Computed once the IPv4 header has been created.
Source Address	Shall be handled as the addresses of the payload message as described in subclause 9.2.1.
Destination Address	Shall be handled as the addresses of the payload message as described in subclause 9.2.1.

Table 3: Derivation of IPv4 Header from IPv6 Header (no fragmentation)

IPv4 field	Value
Version	4
Internet header length	5 (No IPv4 options)
Type of Service and Precedence:	The default behaviour is that the value of the IPv4 field Type of service field is the value of the IPv6 Traffic class field (all 8 bits are copied). An implementation of a TrGW should also provide the ability to ignore the value of the IPv6 Traffic Class and always set the IPv4 Type of Service field to zero.
Total length	The IPv4 Total Length field value is the IPv6 Payload length value plus the size of the IPv4 headers minus 8 for the Fragment header,
Identification	The IPv4 Identification field is copied from the low-order 16-bits in the IPv6 identification field in the IPv6 Fragment header.
Flags	The IPv4 the More Fragments flag is copied from the IPv6 M flag in the IPv6 Fragment header the IPv4 he Don't Fragments flag is set to zero allowing this packet to be fragmented by IPv4 routers.
Time to live (TTL)	The value of the field shall be set to the received IPv6 Hop Limit field value minus 1.
Protocol	The IPv4 field Protocol shall be set to the value of IPv6 field The next header value.
Header checksum	Computed once the IPv4 header has been created
Source Address	Shall be handled as the addresses of the payload message as described in subclause 9.2.1.
Destination Address	Shall be handled as the addresses of the payload message as described in subclause 9.2.1.

Table 4: Derivation of IPv4 Header from IPv6 Header (fragmentation)

9.2.2.4 Abnormal cases

If any of an IPv6 hop-by-hop options header, destination options header, or routing header with the Segments Left field equal to zero are present in the IPv6 packet, they are ignored i.e., there is no attempt to translate them. However, the Total Length field and the Protocol field shall be adjusted to "skip" these extension headers.

If a routing header with a non-zero Segments Left field is present then the packet shall be translated, and an ICMPv6 "parameter problem/ erroneous header field encountered" Type 4/Code 0 error message as defined in IETF RFC 2463 [17], with the Pointer field indicating the first byte of the Segments Left field should be returned to the sender.

9.2.3 Fragmentation

If the DF flag is not set and the IPv4 packet will result in an IPv6 packet larger than 1280 bytes the TrGW shall prior to transferring it in the IPv6 network:

- Add the fragment header to the message
- Fragment the IPv4 packets so that their length, excluding the IPv4 header, is at most 1232 bytes (1280 minus 40 for the IPv6 header and 8 for the Fragment header).

9.2.4 Abnormal cases

As a part of decrementing the Time To Live /Hop Limit value and the TrGW discovers that the zero value is reached the TrGW shall send an ICMPv4/ICMPv6 message with the error “time to live exceeded in transit” type 11 code 0 as defined in IETF RFC 792 [16] and “hop limit exceeded in transit“ type 3 code 0 as defined in IETF RFC 2463 [17].

Annex A (informative): Codecs used for Conversational Services

Codecs used for Conversational Services For codecs for conversational services in the PS domain are defined according to 3GPP TS 26.235 [6]. These include:

- Narrowband speech: The support of the AMR codec is mandated.
- For wideband speech: The support of the AMR-WB codec is mandated
- For video: The support of the H.263 profile 0 level 10 v1 is mandated, and the support of MPEG4 visual sp @ level 0 and ITU-T Recommendation H.263 [14] profile 3 level 10 are optional.

In non-3GPP SIP networks there are no mandatory codecs. However, the following codecs are of interest:

- Narrowband speech: ITU-T Recommendations G.723.1 [15], G.729 [16] and G.711 [17] are known to be commonly deployed.
- Video codecs: ITU-T Recommendation H.263 [14] and MPEG4 are expected to be used.

Annex B (informative): Change history

Change history							
Date	TSG #	TSG Doc.	CR	Rev	Subject/Comment	Old	New
2001-02					Version 0.0.0 Presented to CN3 #16 - Sophia Antipolis - Initial Proposal - TS 29.162 number allocated by MCC		0.0.0
2001-05					Tdocs N3-010226 and N3-010200 agreed at CN3#17 - Rio Grande, Puerto Rico		0.1.0
2001-10					Tdoc N3-010331 agreed at CN3#18 - Dresden, Germany	0.1.0	0.2.0
2001-10					Revised TS based on decision within CN3#19 to reduce the scope of Work Item - as proposed in Tdoc N3-010425. Clean version based on changes agreed in N3-010479 at Cn3#19 - Brighton, UK.	0.2.0	0.3.0
2001-11					Added informative Annex A about interworking between IPv4 and IPv6, as agreed in Cn3#20 Cancun.	0.3.0	0.4.0
2002-01					Included N3-020094, N3-020104, and tidied editors notes.	0.4.0	0.5.0
2002-02					Editorial changes agreed in CN3#21, Sophia Antipolis.	0.5.0	0.6.0
2002-02					DAB, MCC some minor editorials	0.6.0	0.6.1
2002-03					Presented as v1.0.0 to TSG#15 for information	0.6.1	1.0.0
2002-08					Editorial changes agreed in CN3#33, Sophia	1.0.0	1.1.0
2002-09					Editorial corrections made to ensure alignment with 3GPP drafting rules	1.1.0	1.1.1
Change history							
Date	TSG #	TSG Doc.	CR	Rev	Subject/Comment	Old	New
2001-02					Version 0.0.0 Presented to CN3 #16 - Sophia Antipolis - Initial Proposal - TS 29.162 number allocated by MCC		0.0.0
2001-05					Tdocs N3-010226 and N3-010200 agreed at CN3#17 - Rio Grande, Puerto Rico		0.1.0
2001-10					Tdoc N3-010331 agreed at CN3#18 - Dresden, Germany	0.1.0	0.2.0
2001-10					Revised TS based on decision within CN3#19 to reduce the scope of Work Item - as proposed in Tdoc N3-010425. Clean version based on changes agreed in N3-010479 at Cn3#19 - Brighton, UK.	0.2.0	0.3.0
2001-11					Added informative Annex A about interworking between IPv4 and IPv6, as agreed in Cn3#20 Cancun.	0.3.0	0.4.0
2002-01					Included N3-020094, N3-020104, and tidied editors notes.	0.4.0	0.5.0
2002-02					Editorial changes agreed in CN3#21, Sophia Antipolis.	0.5.0	0.6.0
2002-02					DAB, MCC some minor editorials	0.6.0	0.6.1
2002-03					Presented as v1.0.0 to TSG#15 for information	0.6.1	1.0.0
2004-08					Changes e.g. on IPv4-IPv6 interworking agreed in CN3#33, Sophia	1.0.0	1.1.0
2004-09					Editorial corrections made to ensure alignment with 3GPP drafting rules	1.1.0	1.1.1
2004-10					Changes e.g. on IPv4-IPv6 interworking agreed in CN3#33bis, Sophia	1.1.1	1.2.0

Editor: Nigel Holland (nigel.holland@o2.com)