

4th - 6th June 2003. HÄMEENLINNA, Finland.

Source: CN3
Title: TS 29.163: Interworking between the IM CN subsystem and CS networks
Agenda item: 9.13
Document for: INFORMATION

Presentation of Specification to TSG or WG

Presentation to: TSG CN Meeting #20
Document for presentation: TS 29.163, Version 1.7.0
Presented for: Information

Abstract of document:

The document specifies the principles of interworking between the 3GPP IM CN subsystem and BICC/ISUP based legacy CS networks, in order to support IM basic voice calls.

The document addresses the areas of control and user plane interworking between the IM CN subsystem and CS networks through the network functions, which include the MGCF and IM-MGW. For the specification of control plane interworking, areas such as the interworking between SIP and BICC or ISUP are detailed in terms of the processes and protocol mappings required for the support of both IM originated and terminated voice calls.

Other areas addressed encompass the transport protocol and signalling issues for negotiation and mapping of bearer capabilities and QoS information.

Changes since last presentation to CN Meeting #15:

- Mn interface
 - Interworking between SIP and BICC/ISUP specified in 29.163 instead of referring to ITU-T
-

Outstanding Issues:

Completion date for approval: CN#21

Contentious Issues:

none

3GPP TS 29.163 V1.7.0 (2003-06)

Technical Specification

3rd Generation Partnership Project; Technical Specification Group Core Network; Interworking between the IM CN subsystem and CS networks (Release 6)



The present document has been developed within the 3rd Generation Partnership Project (3GPP™) and may be further elaborated for the purposes of 3GPP.

The present document has not been subject to any approval process by the 3GPP Organisational Partners and shall not be implemented. This Specification is provided for future development work within 3GPP only. The Organisational Partners accept no liability for any use of this Specification. Specifications and reports for implementation of the 3GPP™ system should be obtained via the 3GPP Organisational Partners' Publications Offices.

Keywords

IM-MGW, BICC, ISUP, CS, MGCF, CSCF, IM, IM
CN subsystem

3GPP

Postal address

3GPP support office address

650 Route des Lucioles - Sophia Antipolis
Valbonne - FRANCE
Tel.: +33 4 92 94 42 00 Fax: +33 4 93 65 47 16

Internet

<http://www.3gpp.org>

Copyright Notification

No part may be reproduced except as authorized by written permission.
The copyright and the foregoing restriction extend to reproduction in all media.

© 2000, 3GPP Organizational Partners (ARIB, CWTS, ETSI, T1, TTA, TTC).
All rights reserved.

Contents

Foreword.....	9
1 Scope	10
2 References	10
3 Definitions, symbols and abbreviations.....	12
3.1 Definitions.....	12
3.2 Abbreviations	12
4 General	13
4.1 General Interworking Overview.....	13
5 Network characteristics	13
5.1 Key characteristics of ISUP/BICC based CS networks.....	13
5.2 Key characteristics of IM CN Subsystem	13
6 Interworking with CS networks.....	14
6.1 Interworking Reference Model	14
6.1.1 Interworking reference points and interfaces.....	14
6.1.2 Interworking Functional Entities	15
6.1.2.1 Signalling Gateway Function (SGW).....	15
6.1.2.2 Media Gateway Control Function (MGCF).....	15
6.1.2.3 IP Multimedia - Media Gateway Function (IM-MGW)	15
6.2 Control Plane Interworking Model.....	15
6.3 User Plane Interworking Model	15
7 Control Plane Interworking	15
7.1 General	16
7.2 Interworking between CS networks supporting ISUP and the IM CN subsystem	16
7.2.1 Services performed by network entities in the control plane.....	17
7.2.1.1 Services performed by the SS7 signalling function.....	17
7.2.1.2 Services of the SGW.....	17
7.2.1.3 Services of the MGCF	17
7.2.1.4 Services of the SIP signalling function.....	17
7.2.2 Signalling interactions between network entities in the control plane.....	17
7.2.2.1 Signalling between the SS7 signalling function and MGCF	17
7.2.2.1.1 Signalling from MGCF to SS7 signalling function.....	17
7.2.2.1.2 Signalling from SS7 signalling function to MGCF.....	17
7.2.2.1.3 Services offered by SCTP and M3UA	17
7.2.2.1.3.1 Services offered by SCTP.....	18
7.2.2.1.3.2 Services offered by M3UA	18
7.2.2.2 Signalling between the MGCF and SIP signalling function.....	18
7.2.3 SIP-ISUP protocol interworking.....	18
7.2.3.1 Incoming Call Interworking from SIP to ISUP at I-MGCF.....	18
7.2.3.1.1 Sending of IAM	18
7.2.3.1.2 Coding of the IAM.....	19
7.2.3.1.2.1 Called Party Number.....	19
7.2.3.1.2.2 Nature of connection indicators	19
7.2.3.1.2.3 Forward call indicators.....	20
7.2.3.1.2.4 Calling party's category.....	20
7.2.3.1.2.5 Transmission medium requirement.....	20
7.2.3.1.2.6 Calling party number	20
7.2.3.1.2.7 Generic number.....	23
7.2.3.1.2.8 User service information.....	23
7.2.3.1.2.9 Hop Counter (National option)	23
7.2.3.1.3 Sending of COT	24
7.2.3.1.4 Sending of 180 Ringing	24
7.2.3.1.5 Sending of the 200 OK (INVITE).....	25
7.2.3.1.6 Sending of the Release message (REL)	25

7.2.3.1.7	Coding of the REL	26
7.2.3.1.8	Receipt of the Release Message	26
7.2.3.1.9	Receipt of RSC, GRS or CGB (H/W oriented)	27
7.2.3.1.10	Autonomous Release at I-MGCF	28
7.2.3.1.11	Internal through connection of the bearer path	28
7.2.3.2	Outgoing Call Interworking from BICC/ISUP to SIP at O-MGCF	28
7.2.3.2.1	Sending of INVITE	28
7.2.3.2.2	Coding of the INVITE	29
7.2.3.2.2.1	REQUEST URI Header	29
7.2.3.2.2.2	SDP Media Description	29
7.2.3.2.2.3	P-Asserted-Identity, From and Privacy header fields	30
7.2.3.2.2.4	Max Forwards header	32
7.2.3.2.3	Sending of UPDATE	33
7.2.3.2.4	Sending of ACM and Awaiting Answer indication	33
7.2.3.2.5	Coding of the ACM	34
7.2.3.2.5.1	Backward call indicators	34
7.2.3.2.6	Sending of the Call Progress message (CPG)	34
7.2.3.2.7	Coding of the CPG	35
7.2.3.2.7.1	Event information	35
7.2.3.2.8	Sending of the Answer Message (ANM)	35
7.2.3.2.9	Coding of the ANM	35
7.2.3.2.9.1	Backwards Call Indicators	35
7.2.3.2.10	Sending of the Connect message (CON)	35
7.2.3.2.11	Coding of the CON	35
7.2.3.2.11.1	Backward call indicators	36
7.2.3.2.12	Receipt of Status Codes 4xx, 5xx or 6xx	36
7.2.3.2.13	Receipt of a BYE	37
7.2.3.2.14	Receipt of the Release Message	37
7.2.3.2.15	Receipt of RSC, GRS or CGB (H/W oriented)	37
7.2.3.2.16	Autonomous Release at O-MGCF	38
7.2.3.2.17	Special handling of 580 Precondition failure received in response to either an INVITE or UPDATE	38
7.2.3.2.17.1	580 Precondition failure response to an INVITE	38
7.2.3.2.17.2	580 Precondition failure response to an UPDATE within an early dialog	38
7.2.3.3	Timers	38
7.3	Interworking between CS networks supporting BICC and the IM CN subsystem	38
7.3.1	Services performed by network entities in the control plane	40
7.3.2	Signalling interactions between network entities in the control plane	40
7.3.2.1	Signalling between the SS7 signalling function and MGCF	40
7.3.2.1.1	Signalling from MGCF to SS7 signalling function	40
7.3.2.1.2	Signalling from SS7 signalling function to MGCF	40
7.3.2.1.3	Services offered by STC, SCTP and M3UA	40
7.3.2.1.3.1	Services offer by SCTP	40
7.3.2.1.3.2	Services offered by M3UA	40
7.3.2.1.3.3	Services offered by STC	40
7.3.2.2	Signalling between the MGCF and SIP signalling function	40
7.3.3	SIP-BICC protocol interworking	40
7.3.3.1	Incoming Call Interworking from SIP to BICC/ISUP at I-MGCF	40
7.3.3.1.1	Sending of IAM	40
7.3.3.1.2	Coding of IAM	41
7.3.3.1.2.1	Called Party Number	41
7.3.3.1.2.2	Nature of connection indicators	41
7.3.3.1.2.3	Forward call indicators	41
7.3.3.1.2.4	Calling party's category	41
7.3.3.1.2.5	Transmission medium requirement	41
7.3.3.1.2.6	Calling party number	41
7.3.3.1.2.7	Generic number	41
7.3.3.1.2.8	User service information	41
7.3.3.1.2.9	Hop counter (National option)	41
7.3.3.1.3	Sending of COT	42
7.3.3.1.4	Sending of 180 Ringing	42
7.3.3.1.5	Sending of the 200 OK (INVITE)	42
7.3.3.1.6	Sending of the Release message (REL)	42

7.3.3.1.7	Coding of the REL	42
7.3.3.1.8	Receipt of the Release Message	42
7.3.3.1.9	Receipt of RSC, GRS or CGB (H/W oriented)	42
7.3.3.1.10	Internal through connection of the bearer path	42
7.3.3.1.11	Out of Band DTMF	42
7.3.3.2	Outgoing Call Interworking from BICC/ISUP to SIP at O-MGCF	43
7.3.3.2.1	Sending of INVITE	43
7.3.3.2.2	Coding of the INVITE	43
7.3.3.2.2.1	REQUEST URI Header	43
7.3.3.2.2.2	SDP Media Description	43
7.3.3.2.2.3	P-Asserted-Identity and privacy header fields	43
7.3.3.2.2.4	Max Forwards header	43
7.3.3.2.3	Sending of UPDATE	43
7.3.3.2.4	Sending of ACM and Awaiting Answer indication	43
7.3.3.2.5	Coding of the ACM	43
7.3.3.2.5.1	Backward call indicators	43
7.3.3.2.6	Sending of the Call Progress message (CPG)	43
7.3.3.2.7	Coding of the CPG	43
7.3.3.2.7.1	Event information	43
7.3.3.2.8	Sending of the Answer Message (ANM)	44
7.3.3.2.9	Coding of the ANM	44
7.3.3.2.10	Sending of the Connect message (CON)	44
7.3.3.2.11	Coding of the CON	44
7.3.3.2.11.1	Backward call indicators	44
7.3.3.2.12	Receipt of Status Codes 4xx, 5xx or 6xx	44
7.3.3.2.13	Receipt of a BYE	44
7.3.3.2.14	Receipt of the Release Message	44
7.3.3.2.15	Receipt of RSC, GRS or CGB (H/W oriented)	44
7.3.3.2.16	Out of Band DTMF	44
7.3.3.3	Timers	44
7.4	Supplementary services	44
7.4.1	Calling line identification presentation/restriction (CLIP/CLIR)	45
7.4.2	Connected line presentation and restriction (COLP/COLR)	45
7.4.3	Direct dialling in	45
7.4.4	Malicious call identification	45
7.4.5	Sub-addressing (SUB)	45
7.4.6	Call Forwarding Busy (CFB)/ Call Forwarding No Reply (CFNR) / Call Forwarding Unconditional (CFU)	45
7.4.7	Call Deflection (CD)	45
7.4.8	Explicit Call Transfer (ECT)	45
7.4.9	Call Waiting	45
7.4.10	Call Hold	45
7.4.11	Call Completion on busy subscriber	45
7.4.12	Completion of Calls on No Reply (CCNR)	46
7.4.13	Terminal Portability (TP)	46
7.4.14	Conference calling (CONF)	46
7.4.15	Three-Party Service (3PTY)	46
7.4.16	Closed User Group (CUG)	46
7.4.17	Multi-Level Precedence and Preemption (MLPP)	46
7.4.18	Global Virtual Network Service (GVNS)	46
7.4.19	International telecommunication charge card (ITCC)	46
7.4.20	Reverse charging (REV)	46
7.4.21	User-to-User Signalling (UUS)	46
8	User Plane Interworking	46
8.1	Interworking between IM CN subsystem and bearer independent CS network	46
8.2	Interworking between IM CN subsystem and TDM-based CS network	47
8.3	Transcoding requirements	47
8.4	Diffserv Code Point requirements	48
9	MGCF – IM-MGW Interaction	48
9.1	Overview	48

9.2	Mn Signalling Interactions	48
9.2.1	Network Model.....	48
9.2.2	Basic IM CN Subsystem originated Session	49
9.2.2.1	BICC Forward bearer establishment	49
9.2.2.1.1	IM-MGW selection.....	49
9.2.2.1.2	CS network side bearer establishment	49
9.2.2.1.3	IM CN subsystem side termination reservation	49
9.2.2.1.4	IM CN subsystem side session establishment.....	49
9.2.2.1.5	Through-Connection	50
9.2.2.1.6	Codec handling	50
9.2.2.1.7	Failure handling in MGCF.....	50
9.2.2.1.8	Message sequence chart	50
9.2.2.2	BICC Backward bearer establishment.....	52
9.2.2.2.1	IM-MGW selection.....	52
9.2.2.2.2	IM CN subsystem side termination reservation	52
9.2.2.2.3	IM CN subsystem side session establishment.....	52
9.2.2.2.4	CS network side bearer establishment	52
9.2.2.2.5	Through-Connection	53
9.2.2.2.6	Codec handling	53
9.2.2.2.7	Failure handling in MGCF.....	53
9.2.2.2.8	Message sequence chart	53
9.2.2.3	ISUP	55
9.2.2.3.1	IM-MGW selection.....	55
9.2.2.3.2	IM CN subsystem side termination reservation	55
9.2.2.3.3	IM CN subsystem side session establishment.....	55
9.2.2.3.4	CS network side circuit reservation.	55
9.2.2.3.5	Through-Connection	55
9.2.2.3.6	Continuity Check	56
9.2.2.3.7	Codec handling	56
9.2.2.3.8	Voice Processing function	56
9.2.2.3.9	Failure handling in MGCF.....	56
9.2.2.3.10	Message sequence chart	56
9.2.3	Basic CS network originated Session	58
9.2.3.1	BICC Forward bearer establishment	58
9.2.3.1.1	IM-MGW selection.....	58
9.2.3.1.2	IM CN subsystem side termination reservation	58
9.2.3.1.3	IM CN subsystem side session establishment.....	58
9.2.3.1.4	CS network side bearer establishment	58
9.2.3.1.5	Called party alerting.....	58
9.2.3.1.6	Called party answer.....	58
9.2.3.1.7	Through-Connection	59
9.2.3.1.8	Codec handling	59
9.2.3.1.9	Failure handling in MGCF.....	59
9.2.3.1.10	Message sequence chart	59
9.2.3.2	BICC Backward bearer establishment.....	61
9.2.3.2.1	IM-MGW selection.....	61
9.2.3.2.2	CS network side bearer establishment	61
9.2.3.2.3	IM CN subsystem side termination reservation	61
9.2.3.2.4	IM CN subsystem side session establishment.....	62
9.2.3.2.5	Called party alerting.....	62
9.2.3.2.6	Called party answer.....	62
9.2.3.2.7	Through-Connection	62
9.2.3.2.8	Codec handling	62
9.2.3.2.9	Failure handling in MGCF.....	62
9.2.3.2.10	Message sequence chart	62
9.2.3.3	ISUP	64
9.2.3.3.1	IM-MGW selection.....	64
9.2.3.3.2	CS network side circuit reservation	64
9.2.3.3.3	IM CN subsystem side termination reservation	64
9.2.3.3.4	IM CN subsystem side session establishment.....	64
9.2.3.3.5	Called party alerting.....	65
9.2.3.3.6	Called party answer.....	65

9.2.3.3.7	Through-Connection	65
9.2.3.3.8	Continuity Check	65
9.2.3.3.9	Codec handling	65
9.2.3.3.10	Voice Processing function	65
9.2.3.3.11	Failure handling in MGCF.....	66
9.2.3.3.12	Message sequence chart	66
9.2.4	Session release initiated from IM CN subsystem side.....	68
9.2.4.1	BICC	68
9.2.4.1.1	Session release in the IM CN subsystem side	68
9.2.4.1.2	Session release in the CS network side	68
9.2.4.1.3	Message sequence chart	68
9.2.4.2	ISUP	69
9.2.4.2.1	Session release in the IM CN subsystem side	69
9.2.4.2.2	Session release in the CS network side	69
9.2.4.2.3	Message sequence chart	69
9.2.5	Session release initiated from CS network side.....	70
9.2.5.1	BICC	70
9.2.5.1.1	Session release in the CS network side	70
9.2.5.1.2	Session release in the IM CN subsystem side	70
9.2.5.1.3	Message sequence chart	70
9.2.5.2	ISUP	71
9.2.5.2.1	Session release in the CS network side	71
9.2.5.2.2	Session release in the IM CN subsystem side	71
9.2.5.2.3	Message sequence chart	71
9.2.6	Session release initiated by MGCF.....	72
9.2.6.1	BICC	72
9.2.6.1.1	Session release in the CS network side	72
9.2.6.1.2	Session release in the IM CN subsystem side	72
9.2.6.1.3	Message sequence chart	72
9.2.6.2	ISUP	73
9.2.6.2.1	Session release in the CS network side	73
9.2.6.2.2	Session release in the IM CN subsystem side	73
9.2.6.2.3	Message sequence chart	73
9.2.7	Session release initiated by IM-MGW	74
9.2.7.1	BICC	74
9.2.7.1.1	Session release in the CS network side	74
9.2.7.1.2	Session release in the IM CN subsystem side	74
9.2.7.1.3	Message sequence chart	74
9.2.7.2	ISUP	75
9.2.7.2.1	Session release in the CS network side	75
9.2.7.2.2	Session release in the IM CN subsystem side	75
9.2.7.2.3	Message sequence chart	75
9.2.8	Handling of RTP telephony events.....	76
9.2.8.1	Sending DTMF digits out-of-band to CS CN (BICC)	77
9.2.8.2	Sending DTMF digits inband to CS CN (ISUP or BICC)	78
9.3	Mn Signalling Procedures	79
9.3.1	Procedures related to terminations towards the IM CN Subsystem.....	79
9.3.1.1	Reserve IMS Connection Point	79
9.3.1.2	Reserve IMS Multimedia Processing Resource.....	79
9.3.1.3	Change IMS Through-Connection	79
9.3.1.4	Release IMS Termination	79
9.3.1.5	Detect IMS RTP Tel Event.....	80
9.3.1.6	Notify IMS RTP Tel Event.....	80
9.3.1.7	Termination Out-of-Service	81
9.3.2	Procedures related to a termination towards an ISUP network	81
9.3.2.1	Reserve TDM Circuit	81
9.3.2.2	Change TDM Through-Connection.....	82
9.3.2.3	Activate TDM Voice-Processing Function.....	82
9.3.2.4	Send TDM Tone	82
9.3.2.5	Stop TDM Tone.....	82
9.3.2.6	Play TDM Announcement.....	82
9.3.2.7	TDM Announcement Completed	82

9.3.2.8	Stop TDM Announcement.....	82
9.3.2.9	Continuity Check.....	82
9.3.2.10	Continuity Check Verify.....	83
9.3.2.11	Continuity Check Response.....	83
9.3.2.12	Release TDM Termination.....	84
9.3.2.13	Termination Out-of-Service.....	84
9.3.3	Procedures related to a termination towards a BICC network.....	84
9.3.4	Non-call related Procedures.....	85
Annex A (informative): Change history		86

Foreword

This Technical Specification has been produced by the 3rd Generation Partnership Project (3GPP).

The contents of the present document are subject to continuing work within the TSG and may change following formal TSG approval. Should the TSG modify the contents of the present document, it will be re-released by the TSG with an identifying change of release date and an increase in version number as follows:

Version x.y.z

where:

- x the first digit:
 - 1 presented to TSG for information;
 - 2 presented to TSG for approval;
 - 3 or greater indicates TSG approved document under change control.
- y the second digit is incremented for all changes of substance, i.e. technical enhancements, corrections, updates, etc.
- z the third digit is incremented when editorial only changes have been incorporated in the document.

1 Scope

The present document specifies the principles of interworking between the 3GPP IM CN subsystem and BICC/ISUP based legacy CS networks, in order to support IM basic voice calls.

The present document addresses the areas of control and user plane interworking between the IM CN subsystem and CS networks through the network functions, which include the MGCF and IM-MGW. For the specification of control plane interworking, areas such as the interworking between SIP and BICC or ISUP are detailed in terms of the processes and protocol mappings required for the support of both IM originated and terminated voice calls.

Other areas addressed encompass the transport protocol and signalling issues for negotiation and mapping of bearer capabilities and QoS information.

The present document specifies the interworking between 3GPP profile of SIP (as detailed according to 3GPP TS 24.229 [9]) and BICC or ISUP, as specified in ITU-T Q.1902.1 to Q.1902.6 [30] and ITU-T Q761 to Q764 [4] respectively.

The present document addresses two interworking scenarios with respect to the properties of the CS network:.

- The CS network does not use any 3GPP specific additions.
- The CS network uses 3GPP specific additions.

2 References

The following documents contain provisions which, through reference in this text, constitute provisions of the present document.

- References are either specific (identified by date of publication, edition number, version number, etc.) or non-specific.
- For a specific reference, subsequent revisions do not apply.
- For a non-specific reference, the latest version applies.

- [1] ITU Recommendation G.711: "Pulse code modulation (PCM) of voice frequencies".
- [2] ITU-T Recommendation H.248: "Gateway Control Protocol".
- [3] ITU-T Recommendation Q.701 to Q.709 "Specification of Signalling System No.7 – Message Transfer Part".
- [4] ITU-T Recommendations Q.761 to Q.764 (2000) "Specifications of Signalling System No.7 ISDN User Part (ISUP)".
- [5] void
- [6] 3GPP TR 21.905 "Vocabulary for 3GPP Specifications".
- [7] 3GPP TS 29.061 " Interworking between the Public Land Mobile Network (PLMN) supporting Packet Based Services and Packet Data Networks (PDN)".
- [8] 3GPP TS 24.228 "Signalling flows for the IP multimedia call control based on SIP and SDP".
- [9] 3GPP TS 24.229 " IP Multimedia Call Control Protocol based on SIP and SDP ".
- [10] 3GPP TS 23.002 "Network Architecture".
- [11] 3GPP TS 22.228 "Service requirements for the IP Multimedia Core Network Subsystem".

- [12] 3GPP TS 23.228 "IP Multimedia subsystem (IMS)".
- [13] void
- [14] 3GPP TS 29.205: "Application of Q.1900 series to Bearer Independent CS Network architecture; Stage 3".
- [15] 3GPP TS 29.332 "Media Gateway Control Function (MGCF) – IM-Media Gateway (IM-MGW) Interface".
- [16] RFC 791 "Internet Protocol".
- [17] RFC 768 "User Datagram Protocol".
- [18] RFC 2960 "Stream Control Transmission Protocol".
- [19] RFC 3261 "SIP: Session Initiation Protocol".
- [20] 3GPP TS 29.202: "SS7 Signalling Transport in Core Network; Stage 3"
- [21] RFC 2474: "Definition of the Differentiated Services Field (DS Field) in the IPv4 and IPv6 Headers".
- [22] RFC 2475: "An Architecture for Differentiated Services (DiffServ)".
- [23] RFC 3267: "RTP payload format and file storage format for the Adaptive Multi-Rate (AMR) Adaptive Multi-Rate Wideband (AMR-WB) audio codecs"
- [24] RFC 793 "Transmission Control Protocol".
- [25] 3GPP TS 29.414 "Core Network Nb Data Transport and Transport Signalling".
- [26] 3GPP TS 29.415 "Core Network Nb Interface User Plane Protocols".
- [27] 3GPP TS 23.205 "Bearer-independent circuit-switched core network; Stage 2".
- [28] ITU-T Recommendation Q.2150.3 "Signalling Transport Converter on SCTP"
- [29] ITU-T Recommendation Q.2150.1 "Signalling Transport Converter on MTP"
- [30] ITU-T Recommendations Q.1902.1 to Q.1902.6 (07/2001): "Bearer Independent Call Control "
- [31] ITU-T Recommendation Q.1950 (xx/2003) "Call Bearer Control Protocol"
Editor`s Note: When available, insert date of version approved by ITU-T at 28.10.02.
- [32] 3GPP TS 26.236 "Packet Switched Conversational Multimedia Applications; Transport Protocols"
- [33] 3GPP TS 29.232 "Media Gateway Controller (MGC) – Media Gateway (MGW) Interface; Stage 3".
- [34] RFC 2833: "RTP Payload for DTMF Digits, Telephony Tones and Telephony Signals"
- [35] ITU-T Recommendation Q.765.5: "Signalling system No. 7 – Application transport mechanism: Bearer independent call control (BICC)"
- [36] RFC 3264: "An Offer/Answer Model with the Session Description Protocol (SDP)"
- [37] RFC 3312: "Integration of Resource Management and Session Initiation Protocol (SIP)"
- [38] ITU-T Recommendation Q.850 (05/1998) "Usage of cause and location in the Digital Subscriber Signalling System No. 1 and the Signalling System No. 7 ISDN User Part"
- [39] RFC 2460: "Internet Protocol, Version 6 (IPv6) Specification"
- [40] RFC 3323: "A Privacy Mechanism for the Session Initiation Protocol (SIP)"

- [41] RFC 3325: "Private Extensions to the Session Initiation Protocol (SIP) for Asserted Identity within Trusted Networks"
- [42] ITU-T Recommendation Q.730 (12/1999): "ISDN user part supplementary services"
- [47] ITU-T Recommendation E.164 (05/1997): "The international public telecommunication numbering plan"
- [43] ITU-T Recommendation I.363.5 (08/1996): "B-ISDN ATM Adaptation Layer specification: Type 5 AAL"
- [44] ITU-T Recommendation Q.2110 (07/1994): "B-ISDN ATM adaptation layer - Service specific connection oriented protocol (SSCOP)"
- [45] ITU-T Recommendation Q.2140 (02/1995): "B-ISDN ATM adaptation layer - Service specific coordination function for signalling at the network node interface (SSCF at NNI)"
- [46] ITU-T Recommendation Q.2210 (07/1996): "Message transfer part level 3 functions and messages using the services of ITU-T Recommendation Q.2140"
- [47] 3GPP TS 23.221 "Architectural requirements"

3 Definitions, symbols and abbreviations

3.1 Definitions

For the purposes of the present document, the terms and definitions given in 3GPP TR 21.905 [6] and the following apply:

SS7 signalling function: A function in the CS network, which has the capabilities to transport the SS7 MTP-User parts ISUP and BICC+STC_{mtp}

SIP signalling function: A function in the IM CN subsystem, which has the capabilities to transport SIP

Incoming or Outgoing: This term is used in this Specification to indicate the direction of a call (not signalling information) with respect to a reference point.

Incoming MGCF (I-MGCF): An entity that terminates incoming SIP calls from the IMS side and originates outgoing calls towards the CS side using the BICC or ISUP protocols.

Outgoing Interworking Unit (O-MGCF): An entity that terminates incoming BICC or ISUP calls from the CS side and originates outgoing calls towards the IMS using SIP.

Signalling Transport Converter (STC): A function that converts the services provided by a particular Signalling Transport to the services required by the Generic Signalling Transport Service.

STC_{mtp}: Signalling Transport Converter on MTP. See ITU-T Recommendation Q.2150.1 [29]

BICC+STC_{mtp}: By this terminology is meant that BICC signaling always need to be used on top of STC_{mtp} sublayer.

For the purposes of the present document, the following terms and definitions given in ITU-T E.164 [47] apply:

International public telecommunication number

3.2 Abbreviations

For the purposes of the present document, the abbreviations as specified in 3GPP TR 21.905 [6] apply and the following apply:

M3UA MTP-L3 User Adaptation Layer

IM-MGW	IP Multimedia Media Gateway Function
SGW	Signalling Gateway
CC	Country Code
NDC	National Destination Code
SN	Subscriber Number
NOA	Nature of Address Indicator

4 General

4.1 General Interworking Overview

The IM CN subsystem shall interwork with BICC and ISUP based legacy CS networks, e.g. PSTN, ISDN, CS PLMNs, in order to provide the ability to support basic voice calls (see 3GPP TS 22.228 [11]), between a UE located in the IM CN subsystem and user equipment located in a CS network.

For the ability to support the delivery of basic voice calls between the IM CN subsystem and CS networks, basic protocol interworking between SIP (as specified in TS 24.229 [9]) and BICC or ISUP (as specified in ITU-T Q.1902.1-6 [30] and ITU-T Q761 to Q764 [4] respectively) has to occur at a control plane level, in order that call setup, call maintenance and call release procedures can be supported. The MGCF shall provide this protocol mapping functionality within the IM CN subsystem.

User plane interworking between the IM CN subsystem and CS network bearers (e.g. 64k TDM, ATM/AAL2 circuit or IP bearer) are supported by the functions within the IM-MGW. The IM-MGW resides in the IM CN subsystem and shall provide the bearer channel interconnection. The MGCF shall provide the call control to bearer setup association.

The IM CN subsystem shall interwork, at the control and user plane, with BICC and ISUP based legacy CS networks. The support of supplementary services shall be as defined in 3GPP TS 22.228 [11]. The MGCF and IMS-MGW shall support the interworking of the IM CN subsystem to an external ISUP based CS network. They may also support interworking to a BICC based CS network where no 3GPP specific extension is applied. The MGCF and the IM-MGW may also support interworking to a BICC based CS network where 3GPP specific extensions in accordance with 3GPP TS 29.205 [14] are applied.

5 Network characteristics

5.1 Key characteristics of ISUP/BICC based CS networks

This signalling interface to a PSTN is either based on BICC Capability Set 2 as specified in Q.1902.1 to Q.1902.6 [30], or on ISUP (see ITU-T Q.761 to Q.764 [4]).

The interface towards a CS-PLMN may either be one of the interfaces mentioned in the paragraph above or a signalling interface based on BICC with 3GPP specific extensions, as specified for the 3GPP Nc interface in 3GPP TS 29.205 [14], and the IM-MGW may support the 3GPP Nb interface, as specified in 3GPP TS 29.414 [25] and 3GPP TS 29.415 [26]. If the 3GPP Nc interface is applied as signalling interface, the 3GPP Nb interface is used as user plane interface and the Nb UP Framing protocol is applied.

5.2 Key characteristics of IM CN Subsystem

The IM CN subsystem uses SIP to manage IP multimedia sessions in a 3GPP environment, it also uses IPv6 as the transport mechanism for both SIP session signalling and media transport.

6 Interworking with CS networks

6.1 Interworking Reference Model

Figure 1 details the reference model required to support interworking between the 3GPP IM CN subsystem and CS networks for IM basic voice calls.

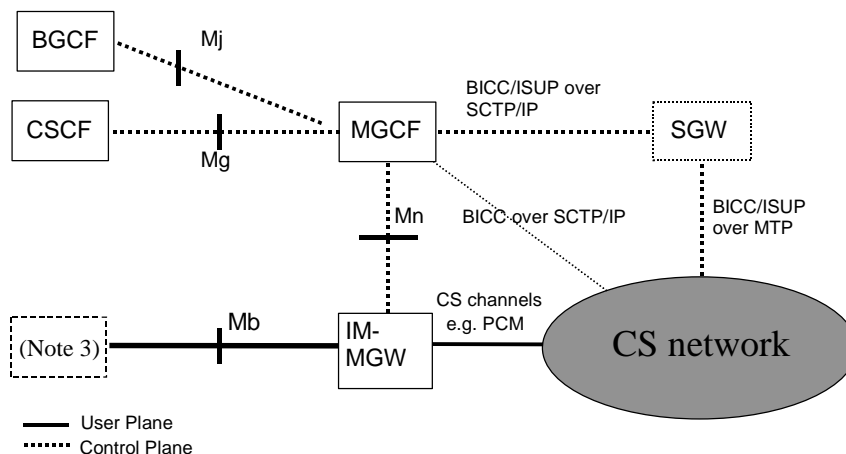

NOTE 1: The logical split of the signalling and bearer path between the CS network and the IM CN subsystem is as shown, however the signalling and bearer may be logically directly connected to the IM-MGW.

NOTE 2: The SGW may be implemented as a stand-alone entity or it may be located in another entity either in the CS network or the IM-MGW. The implementation options are not discussed in the present document.

NOTE 3: The IM-MGW may be connected via the Mb to various network entities, such as a UE (via a GTP Tunnel to a GGSN), an MRFP, or an application server.

NOTE 4: A SGW function is not required for certain signalling transports, where M3UA+SCTP+IP is used in CS network and IM-MGCF.

Figure 1: IM CN subsystem to CS network logical interworking reference model

6.1.1 Interworking reference points and interfaces

The reference points and network interfaces shown in Figure 1 are as described:

Protocol for Mg reference point: The single call control protocol applied across the Mg reference point (i.e. between CSCF and MGCF) will be based on the 3GPP profile of SIP as defined in accordance with 3GPP TS 24.229 [9].

Protocol for Mn reference point: The Mn reference point describes the interfaces between the MGCF and IM-MGW, and has the properties as detailed in 3GPP TS 29.332 [15].

Protocol for Mj reference point: The single call control protocol applied across the Mj reference point (i.e. between BGCF and MGCF) will be based on the 3GPP profile of SIP as defined in accordance with 3GPP TS 24.229 [9].

Protocol for Mb reference point: The Mb reference point is defined in accordance with 3GPP TS 23.002 [10] and is IPv6 based.

6.1.2 Interworking Functional Entities

6.1.2.1 Signalling Gateway Function (SGW)

This component performs the call related signalling conversion to or from BICC/ISUP based MTP transport networks to BICC/ISUP based SCTP/IP transport networks, and forwards the converted signalling to or from the MGCF. The functionality within SGW shall be in accordance with 3GPP TS 23.002 [10].

6.1.2.2 Media Gateway Control Function (MGCF)

This is the component within the IM CN subsystem, which controls the IM-MGW, and also performs SIP to BICC or SIP to ISUP call related signalling interworking.

The functionality defined within MGCF shall be defined in accordance with 3GPP TS 23.002 [10].

6.1.2.3 IP Multimedia - Media Gateway Function (IM-MGW)

This is the component within the IM CN subsystem, which provides the interface between the PS domain and the CS domain, and it shall support the functions as defined in accordance with 3GPP TS 23.002 [10].

6.2 Control Plane Interworking Model

Within the IM CN subsystem, the 3GPP profile of SIP is used to originate and terminate IM sessions to and from the UE.

External CS networks use BICC or ISUP to originate and terminate voice calls to and from the IM CN subsystem.

Therefore, in order to provide the required interworking to enable inter network session control, the control plane protocols shall be interworked within the IM CN subsystem. This function is performed within the MGCF (see Subclause 6.1.2).

6.3 User Plane Interworking Model

Within the IM CN subsystem, IPv6, and framing protocols such as RTP, are used to transport media packets to and from the IM CN subsystem entity like UE or MRFP.

External legacy CS networks use circuit switched bearer channels like TDM circuits (e.g. 64kbits PCM), ATM/AAL2 circuit or IP bearers to carry encoded voice frames, to and from the IM CN subsystem.

Other CN networks use ATM/AAL 1 or AAL 2 or IP as a backbone, with different framing protocols.

Therefore, in order to provide the required interworking to enable media data exchange, the user plane protocols shall be translated within the IM CN subsystem. This function is performed within the IM-MGW (see Subclause 6.1.2).

7 Control Plane Interworking

Signalling from CS networks to or from IM CN subsystem, where the associated supported signalling protocols are SS7/M3UA+ SCTP+IP and M3UA+SCTP+IP respectively, requires a level of interworking between the nodes across the Control Plane, i.e. the SS7 signalling function, SGW (if applicable), MGCF and SIP signalling function. This interworking is required in order to provide a seamless support of a user part, i.e. SIP and BICC+STC_{mtp} or SIP and ISUP.

The transport of SS7 signalling protocol messages of any protocol layer that is identified by MTP level 3, in SS7 terms, as a user part (MTP3-user) shall be accomplished in accordance with the protocol architecture defined in the following subclauses. For the present document these protocol layers include, but are not limited to, Bearer Independent Call Control (BICC)+STC_{mtp} and ISDN User Part (ISUP).

7.1 General

The following sub-clauses define the signalling interworking between the Bearer Independent Call Control (BICC) or ISDN User Part (ISUP) protocols and Session Initiation Protocol (SIP) with its associated Session Description Protocol (SDP) at a MGCF. The services that can be supported through the use of the signalling interworking are limited to the services that are supported by BICC or ISUP and SIP based network domains.

BICC is the call control protocol used between Nodes in a network that incorporates separate call and bearer control. The BICC/ISUP capabilities or signalling information defined for national use is outside the scope of the present document. It does not imply interworking for national-specific capabilities is not feasible.

The capabilities of SIP and SDP that are interworked with BICC or ISUP are defined in 3GPP TS 24.229 [9]

Services that are common in SIP and BICC or ISUP network domains will seamlessly interwork by using the function of the MGCF. The MGCF will originate and/or terminate services or capabilities that do not interwork seamlessly across domains according to the relevant protocol recommendation or specification.

Table 1 lists the services seamlessly interworked and therefore within the scope of the present document.

Table 1: Interworking Capabilities between BICC/ISUP and SIP profile for 3GPP

Service
Speech/3.1 kHz audio
<i>En bloc</i> address signalling
Out of band transport of DTMF tones and information. (BICC only)
Direct-Dialling-In (DDI)
Multiple Subscriber Number (MSN)
Calling Line Identification Presentation (CLIP)
Calling Line Identification Restriction (CLIR)

7.2 Interworking between CS networks supporting ISUP and the IM CN subsystem

The control plane between CS networks supporting ISUP and the IM CN subsystem supporting SIP, where the underlying network is SS7 and IP respectively is as shown in Figure 2.

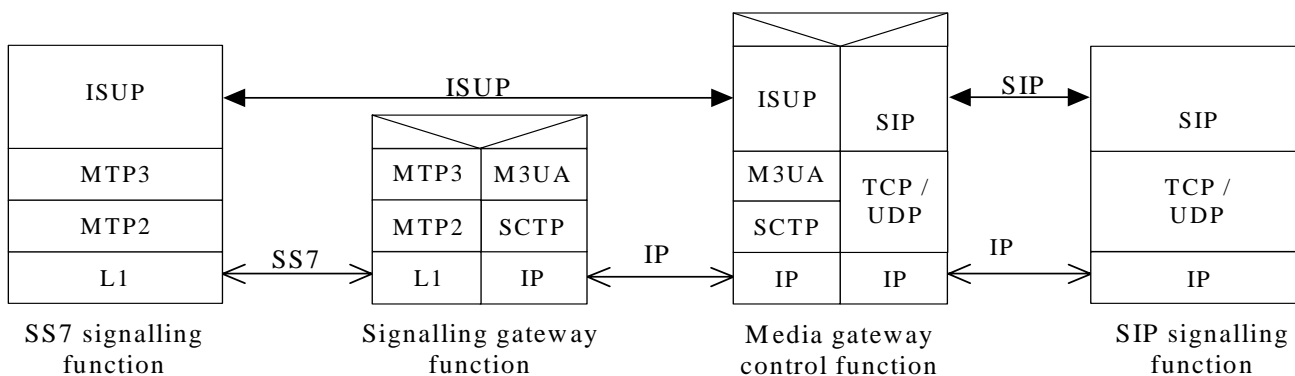

Figure 2: Control Plane interworking between CS networks supporting ISUP and the IM CN subsystem

7.2.1 Services performed by network entities in the control plane

7.2.1.1 Services performed by the SS7 signalling function

The SS7 signalling function provides the capabilities to deliver or receive SS7 MTP3-User information (e.g. ISUP or BICC+STC_{mtp}) across the SS7 signalling network. The functional interface of the MTP, the MTP User parts and the signalling network are as detailed in ITU-T Q.701 to Q.709 [3].

7.2.1.2 Services of the SGW

The SGW shall perform the functions as described in 3GPP TS 23.002 [10].

In order to support the seamless operation of the MTP3-User part information between networks incorporating SS7 and IP, the SGW shall support the services of MTP as well as the services of the M3UA (see 3GPP TS 29.202 [20]) and SCTP (see RFC 2960 [18]).

7.2.1.3 Services of the MGCF

The session handling and session control of the MGCF shall be as detailed in 3GPP TS 24.229 [9].

The MGCF shall provide the interaction, through the use of its interworking function, between the SS7 MTP3-User part information, e.g. ISUP, and SIP. It shall also provide the interaction between the mechanism used to transport the SS7 MTP3-User part information and SIP, i.e. the interaction between M3UA and SCTP and UDP/TCP (see RFC 768 [17] and RFC 793 [24]).

The MGCF interworking function shall also provide the translation between the SS7 MTP3-User part information and SIP, where the interworking of SIP to ISUP and BICC+STC_{mtp} are detailed below.

7.2.1.4 Services of the SIP signalling function

The SIP signalling function provides the capabilities to deliver or receive multimedia session information across the IM CN subsystem signalling system. It is a logical entity that may reside in the CSCF, MGCF and other IM CN subsystem entities.

7.2.2 Signalling interactions between network entities in the control plane

7.2.2.1 Signalling between the SS7 signalling function and MGCF

The SGW shall enable the signalling interaction between the SS7 signalling function and the MGCF.

7.2.2.1.1 Signalling from MGCF to SS7 signalling function

For signalling from the MGCF to the SS7 signalling function, the SGW shall terminate the SCTP and M3UA protocol layers and deliver the MTP3-User protocol messages, e.g. ISUP messages, towards the SS7 signalling function. The SGW transmits and receives SS7 Message Signalling Units (MSUs) to and from the SS7 signalling function over standard SS7 network interfaces, using MTP to provide reliable transport of the messages.

7.2.2.1.2 Signalling from SS7 signalling function to MGCF

For signalling from the SS7 signalling function to the MGCF, the SGW shall terminate SS7 MTP2 and MTP3 protocol layers and deliver MTP3-User part information messages, e.g. ISUP, towards the MGCF. In order to direct messages received from the SS7 MTP3 network to the appropriate IP destination, e.g. MGCF, the SGW shall perform a message distribution function using the information received from the MTP3-User message. Message distribution at the SGW shall be performed in accordance with 3GPP TS 29.202 [20].

7.2.2.1.3 Services offered by SCTP and M3UA

The SGW internal protocol mapping and transportation between BICC or ISUP messages and IP encapsulated BICC or ISUP messages respectively is supported by the services of the M3UA adaptation layer and the underlying SCTP layer.

The SGW shall allow for the transfer of MTP3-User signalling messages, e.g. BICC or ISUP, to and from an MGCF, where the peer MTP3-User protocol exists.

7.2.2.1.3.1 Services offered by SCTP

SCTP offers the ability to reliably transfer the SCTP User applications, e.g. M3UA, between the SCTP User application peers. The initialisation procedure used for an association between two SCTP end-to-end peers, and the initialisation to the SCTP User applications shall be detailed in accordance with RCF 2960 [18].

7.2.2.1.3.2 Services offered by M3UA

When an association between two SCTP peers has been established, the use of M3UA shall provide the transport of MTP-TRANSFER primitives (see ITU-T Q.701 to Q.709 [3]) to its upper layer to the MTP3-User, e.g. ISUP.

7.2.2.2 Signalling between the MGCF and SIP signalling function

Signalling between the SIP signalling function and the MGCF shall use the services of IP, TCP or UDP and SIP. The use of a SIP URL shall enable the identification of the IP address of the IM CN subsystem entity, e.g. the MGCF and SIP signalling function.

The naming and addressing concepts between the MGCF and SIP signalling function shall be detailed in accordance with 3GPP TS 23.228 [12]. The issues of general IP address management are discussed in 3GPP TS 23.221 [47].

7.2.3 SIP-ISUP protocol interworking

When a coding of a parameter value is omitted it implies that it is not affected by the interworking and the values are assigned by normal protocol procedures.

7.2.3.1 Incoming Call Interworking from SIP to ISUP at I-MGCF

7.2.3.1.1 Sending of IAM

On reception of the INVITE requesting an audio session, the I-MGCF shall send the IAM.

If a Continuity Check procedure is supported in the ISUP network, the I-MGCF shall send the IAM immediately after the reception of the INVITE, as shown in Figure 3. This procedure applies when the value of the continuity indicator is either set to “continuity check required” or “continuity check performed on a previous circuit”. If the continuity indicator is set to “continuity check required” the corresponding procedures at the Mn interface described in Subclause 9.2.2.3 also apply.

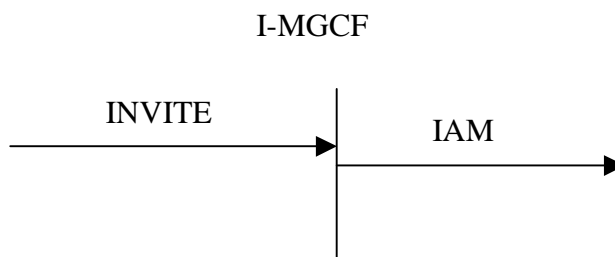

Figure 3: Receipt of an Invite request (Continuity procedure supported in the ISUP network)

If no Continuity Check procedure is supported in the ISUP network, the I-MGCF shall delay sending the IAM until the SIP preconditions are met:

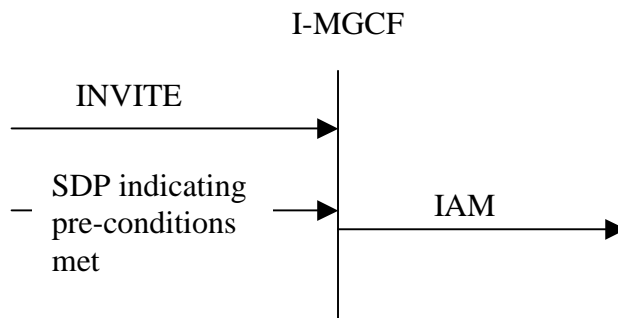

Figure 4: Receipt of an Invite request (Continuity procedure not supported in the ISUP network)

The I-MGCF shall reject an INVITE request for a non-audio session by sending a status code 503 “Service not available”. If audio media streams and non-audio media streams are contained in a single INVITE request, the non-audio media streams shall be rejected in the SDP answer, as detailed in IETF RFC 3264 [36].

7.2.3.1.2 Coding of the IAM

The following ISDN user part parameters description can be found in ITU-T Q.763 [4].

7.2.3.1.2.1 Called Party Number

The E.164 address encoded in the Request-URI shall be mapped to the called party number parameter of the IAM message.

Table 2: Coding of the Called Party Number

INVITE→ Request-URI	IAM→ Called Party Number
E.164 address (e.g. as Userinfo in SIP URI with user=phone, or as tel URL)	Address Signal

7.2.3.1.2.2 Nature of connection indicators

- bits BA Satellite indicator
 - 0 1 one satellite circuit in the connection
- bits DC Continuity check indicator
 - 0 0 *continuity check not required*) if the continuity check procedure is not supported in the succeeding network (Figure 4).
 - 0 1 *continuity check required*, if a continuity check shall be carried out on the succeeding circuit. (Figure 3)
 - 1 0 continuity check performed on a previous circuit otherwise, if the continuity check procedure is supported in the succeeding network, but shall not be carried out on the succeeding circuit otherwise. (Figure 3)
- bit E Echo control device indicator
 - 1 outgoing echo control device included

7.2.3.1.2.3 Forward call indicators

bits	<u>CB</u>	End-to-end method indicator
	0 0	no end-to-end method available (only link-by-link method available)
bit	<u>D</u>	Interworking indicator
	1	interworking encountered
bit	<u>E</u>	End-to-end information indicator (national use)
	0	no end-to-end information available
bit	<u>F</u>	ISDN user part/BICC indicator
	0	ISDN user part/BICC not used all the way
bits	<u>HG</u>	ISDN user part/BICC preference indicator
	0 1	ISDN user part/BICC not required all the way
bit	<u>I</u>	ISDN access indicator
	0	originating access non-ISDN
bits	<u>KJ</u>	SCCP method indicator
	0 0	no indication

7.2.3.1.2.4 Calling party's category

0 0 0 0 1 0 1 0 ordinary calling subscriber

7.2.3.1.2.5 Transmission medium requirement

The TMR parameter is set to "3.1 kHz audio" or "speech".

7.2.3.1.2.6 Calling party number

The SIP "Privacy" header is defined within RFC 3323 [40]. The SIP "P-Asserted-Identity" header is defined in RFC 3325 [41].

Table 3: Mapping of SIP From/P-Asserted-Identity/Privacy headers to CLI parameters

Has a "P-Asserted-Identity" header field (Note 2, Note 5, Note 6) been received?	Has a "From" header field (Note 3) containing a URI that encodes an E.164 address been received (Note 6)?	Calling Party Number parameter Address signals	Calling Party Number parameter APRI	Generic Number (additional calling party number) address signals	Generic Number parameter APRI
No	No	Network option to either include a network provided E.164 number (See Table 4) or omit the Address signals. (Note 4)	Network option to set APRI to "presentation restricted" or "presentation allowed" (Note 4) (See Table 5)	Parameter not included	Not applicable
No	Yes	Network Option to either include a network provided E.164 number (See Table 4) or omit the Address signals. (Note 4)	Network option to set APRI to "presentation restricted" or "presentation allowed" (Note 4) (See Table 5)	Network Option to either omit the parameter (if CgPN has been omitted) or derive from the "From" header (Note 1) (See Table 6)	APRI = "presentation restricted" or "presentation allowed" depending on SIP Privacy header. (See Table 6)
Yes	No	Derive from P-Asserted-Identity (See Table 5)	APRI = "presentation restricted" or "presentation allowed" depending on SIP Privacy header. (See Table 5)	Not included	Not applicable
Yes	Yes	Derived from P-Asserted-Identity (See Table 5)	APRI = "presentation restricted" or "presentation allowed" depending on SIP Privacy header. (See Table 5)	Network Option to either omit the parameter or derive from the "From" header (Note 1) (See Table 6)	APRI = "presentation restricted" or "presentation allowed" depending on SIP Privacy header. (see Table 6)
<p>Note 1: This mapping effectively gives the equivalent of Special Arrangement to <u>all</u> SIP UAC with access to the I-MGCF.</p> <p>Note 2: It is possible that the P-Asserted-Identity header field includes both a tel URL and a sip or sips URI. In this case, the tel URL is used.</p> <p>Note 3: The "From" header may contain an "Anonymous URI". An "Anonymous URI" includes information that does not point to the calling party. RFC 3261 recommends that the display-name component contain "Anonymous". RFC 3323 [40] recommends that the Anonymous URI itself have the value "anonymous@anonymous.invalid".</p> <p>Note 4: A national option exists to set the APRI to "Address not available".</p> <p>Note 5: TS 24.229 guarantees that the received number is an E.164 number formatted as an international number, with a "+" sign as prefix.</p> <p>Note 6: The E.164 numbers considered within this specification are composed by a CC (Country Code), followed by a NDC (National Destination Code), followed by a SN (Subscriber Number). On the IMS side, the numbers are international public telecommunication numbers ("CC"+"NDC"+"SN") and are prefixed by a "+" sign. On the CS side, it is a network option to omit the CC.</p>					

Table 4: Setting of the Network-provided BICC/ISUP Calling Party Number parameter with a CLI (Network Option)

BICC/ISUP CgPN Parameter field	Value
Screening Indicator	"network provided"
Number Incomplete Indicator	"complete"
Number Plan Indicator	ISDN/Telephony (E.164)
Address Presentation Restricted Indicator	Presentation allowed/restricted
Nature of Address Indicator	If next BICC/ISUP node is located in the same country set to "National (Significant) number" else set to "International number"
Address signals	If NOA is "national (significant) number" no country code should be included. If NOA is "international number", then the country code of the network-provided number should be included.

Table 5: Mapping of P-Asserted-Identity and Privacy Headers to the ISUP/BICC Calling Party Number Parameter

SIP Component	Value	BICC/ISUP Parameter / field	Value
P-Asserted-Identity header field (Note 1)	E.164 number	Calling Party Number	
		Number incomplete indicator	"Complete"
		Numbering Plan Indicator	"ISDN/Telephony (E.164)"
		Nature of Address Indicator	If CC encoded in the URI is equal to the CC of the country where MGCF is located AND the next BICC/ISUP node is located in the same country then set to "national (significant) number" else set to "international number"
		Address Presentation Restricted Indicator (APRI)	Depends on priv-value in Privacy header.
		Screening indicator	Network Provided
Addr-spec	"CC" "NDC" "SN" from the URI	Address signal	if NOA is "national (significant) number" then set to "NDC" + "SN" If NOA is "international number" Then set to "CC"+"NDC"+"SN"
Privacy header field is not present		APRI	Presentation allowed
Privacy header field	priv-value	APRI	"Address Presentation Restricted Indicator"
priv-value (Note 2)	"header"	APRI	Presentation restricted
	"user"	APRI	Presentation restricted
	"none"	APRI	Presentation allowed
	"id"	APRI	Presentation restricted
<p>Note 1: It is possible that a P-Asserted-Identity header field includes both a TEL URI and a SIP or SIPS URI. In this case, the TEL URL is used..</p> <p>Note 2: It is possible to receive two priv-values, one of which is "none", the other "id". In this case, the APRI shall be set to <i>Presentation restricted</i></p>			

7.2.3.1.2.7 Generic number

Table 6: Mapping of SIP From Header Field to BICC/ISUP Generic Number (additional calling party number) parameter (Network option)

SIP Component	Value	BICC/ISUP Parameter / field	Value
From header field	name-addr or addr-spec	Generic Number Number Qualifier Indicator	"Additional Calling Party number"
from-spec	(name-addr / addr-spec)		
		Nature of Address Indicator	If CC encoded in the URI is equal to the CC of the country where MGCF is located AND the next BICC/ISUP node is located in the same country then Set to "national (significant) number" Else set to "international number"
		Number incomplete indicator	"Complete"
		Numbering Plan Indicator	"ISDN/Telephony (E.164)"
		APRI	Depends on priv-value
		Screening indicator	"user provided not verified"
Addr-spec	"CC" "NDC" + "SN" from the URI	Address signal	if NOA is "national (significant) number" then set to "NDC" + "SN" If NOA is "international number" Then set to "CC"+"NDC"+"SN"
Privacy header field	priv-value	APRI	"Address Presentation Restricted Indicator"
Use same APRI setting as for Calling Party Number.			

7.2.3.1.2.8 User service information

The Information Transfer Capability Information element is coded as "speech" or "3.1 khz audio".

7.2.3.1.2.9 Hop Counter (National option)

The I-MGCF shall perform the following interworking procedure if the Hop Counter procedure is supported in the CS network.

At the I-MGCF the Max-Forwards SIP header shall be used to derive the Hop Counter parameter if applicable. Due to the different default values (that are based on network demands/provisions) of the SIP Max-Forwards header and the Hop Counter, a factor shall be used to adapt the Max Forwards to the Hop Counter at the I-MGCF. For example, the following guidelines could be applied.

- 1) Max-Forwards for a given message should be monotone decreasing with each successive visit to a SIP entity, regardless of intervening interworking, and similarly for Hop Counter.
- 2) The initial and successively mapped values of Max-Forwards should be large enough to accommodate the maximum number of hops that may be expected of a validly routed call.

Table 7 shows the principle of the mapping:

Table 7: Max forwards -- hop counter

Max-Forwards	= X	Hop Counter	= INTEGER part of (X /Factor) =Y
Note: The Mapping of value X to Y should be done with the used (implemented) adaptation mechanism.			

The Principle of adoption could be implemented on a basis of the network provision, trust domain rules and bilateral agreement.

7.2.3.1.3 Sending of COT

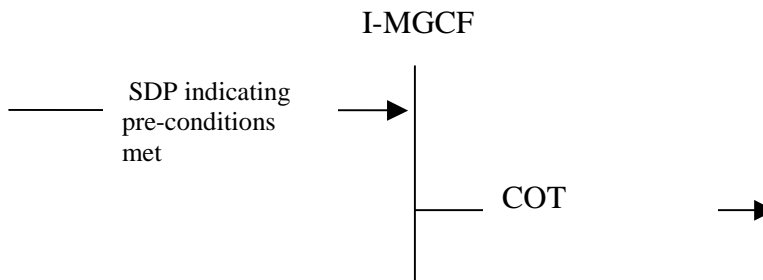

Figure 5: Sending of COT

If the IAM has already been sent, the Continuity message shall be sent indicating “successful”, when all of the following conditions have been met:

- the requested preconditions in the IMS network have been met
- A possible outstanding continuity check procedure is successfully performed on the outgoing circuit

7.2.3.1.4 Sending of 180 Ringing

The I-MGCF shall send the SIP 180 Ringing when receiving any of the following messages:

- ACM with Called party's status indicator set to subscriber free

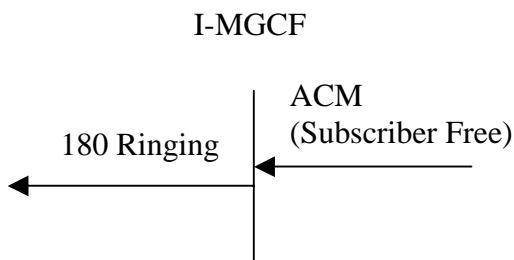

Figure 6: The receipt of ACM

- CPG with Event indicator set to alerting

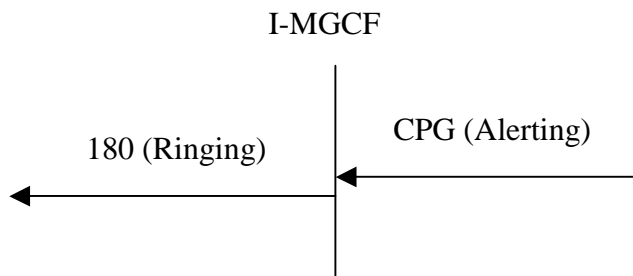

Figure 7: Receipt of CPG (Alerting)

7.2.3.1.5 Sending of the 200 OK (INVITE)

The following cases are possible trigger conditions for sending the 200 OK (INVITE):

- The reception of the ANM

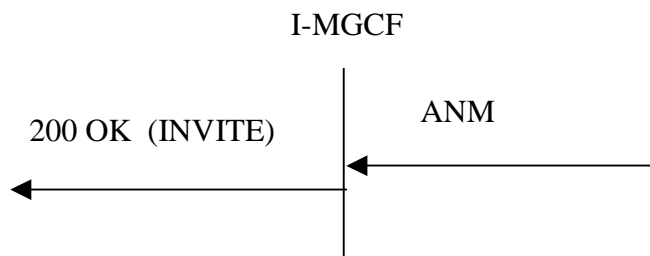

Figure 8: Receipt of ANM

- The reception of the CON message

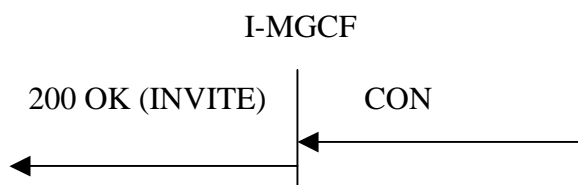

Figure 9: Receipt of CON

7.2.3.1.6 Sending of the Release message (REL)

The following are possible triggers for sending the Release message:

- Receipt of the BYE method

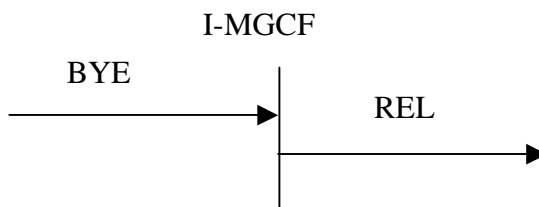

Figure 10: Receipt of the Bye method

- Receipt of the CANCEL method

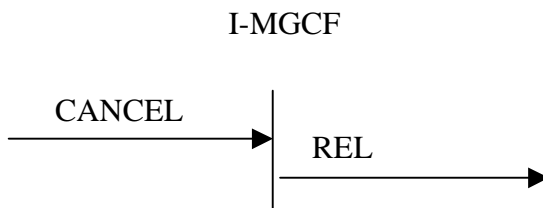

Figure 11: Receipt of Cancel method

Additional triggers are contained in Table 10.

7.2.3.1.7 Coding of the REL

The SIP BYE and CANCEL requests are mapped into a REL message with cause value #16 and #31 respectively as indicated in table 8.

Table 8: Coding of REL

SIP Message →	REL →
Request	cause parameter
BYE	Cause value No. 16 (normal clearing)
CANCEL	Cause value No. 31 (normal unspecified)

7.2.3.1.8 Receipt of the Release Message

If the REL message is received and a final response (i.e. 200 OK (INVITE)) has already been sent, the I-MGCF shall send a BYE message.

NOTE: According to SIP procedures, in the case that the REL message is received and a final response (e.g. 200 OK (INVITE)) has already been sent (but no ACK has been received) on the incoming side of the I-MGCF then the I-MGCF does not send a 487 Request terminated and instead waits until the ACK is received before sending a BYE message.

If the REL message is received and the final response (i.e. 200 OK (INVITE)) has not already been sent, the I-MGCF shall send Status-Code 4xx (Client Error) or 5xx (Server Error). The Status code to be sent is determined by examining the Cause code value received in the REL message. Table 9 specifies the mapping of the cause code values, as defined in ITU-T Q.850 [38], to SIP response status codes.

Table 9: Receipt of the Release message (REL)

←SIP Message	← REL
Status code	Cause parameter
404 Not Found	Cause value No. 1 (unallocated (unassigned) number)
503 Service unavailable	Cause value No 2 (no route to network)
503 Service unavailable	Cause value No 3 (no route to destination)
503 Service unavailable	Cause value No. 4 (Send special information tone)
404 Not Found	Cause value No. 5 (Misdialed trunk prefix)
486 Busy Here	Cause value No. 17 (user busy)
480 Temporarily unavailable	Cause value No 18 (no user responding)
480 Temporarily unavailable	Cause value No 19 (no answer from the user)
480 Temporarily unavailable	Cause value No. 20 (subscriber absent)
480Temporarily unavailable	Cause value No 21 (call rejected)

←SIP Message	← REL
Status code	Cause parameter
410 Gone	Cause value No 22 (number changed)
480 Temporarily unavailable	Cause value No 25 (Exchange routing error)
502 Bad Gateway	Cause value No 27 (destination out of order)
484 Address Incomplete	Cause value No. 28 invalid number format (address incomplete)
503 Service unavailable	Cause value No 29 (facility rejected)
484 Address Incomplete	Cause value No. 28 invalid number format (address incomplete)
480 Temporarily unavailable	Cause value No 31 (normal unspecified) (class default)
486 Busy here if Diagnostics indicator includes the (CCBS indicator = CCBS possible) else 480 Temporarily unavailable	Cause value in the Class 010 (resource unavailable, Cause value No 34)
503 Service unavailable	Cause value in the Class 010 (resource unavailable, Cause value No's. 38, 41, 42, 43, 44, & 47) (47 is class default)
503 Service unavailable	Cause value No 50 (requested facility no subscribed)
503 Service unavailable	Cause value No 57 (bearer capability not authorised)
503 Service unavailable	Cause value No 58 (bearer capability not presently)
503 Service unavailable	Cause value No 63 (service option not available, unspecified)
503 Service unavailable	Cause value in the Class 100 (service or option not implemented, Cause value No's. 65, 70 & 79) 79 is class default
503 Service unavailable	Cause value No 88 (incompatible destination)
404 Not Found	Cause value No 91 (invalid transit network selection)
503 Service unavailable	Cause value No 95 (invalid message)
503 Service unavailable	Cause value No 97 (Message type non-existent or not implemented)
503 Service unavailable	Cause value No 99 (information element/parameter non-existent or not implemented)
480 Temporarily unavailable	Cause value No. 102 (recovery on timer expiry)
503 Service unavailable	Cause value No 110 (Message with unrecognised Parameter, discarded)
503 Service unavailable	Cause value No. 111 (protocol error, unspecified)
480 Temporarily unavailable	Cause value No. 127 (interworking unspecified)

7.2.3.1.9 Receipt of RSC, GRS or CGB (H/W oriented)

If a RSC, GRS or CGB (H/W oriented) message is received after an initial address message has been sent for that circuit and after at least one backward message relating to that call has been received then:

- 1) If the final response (i.e. 200 OK (INVITE)) has already been sent, the I-MGCF shall send a BYE message.
- 2) If the final response (i.e. 200 OK (INVITE)) has not already been sent, the I-MGCF shall send a SIP response with Status-Code 480 Temporarily Unavailable.

7.2.3.1.10 Autonomous Release at I-MGCF

Table 10 shows the trigger events at the MGCF and the release initiated by the MGCF when the call is traversing from SIP to ISUP/BICC.

Table 10: Autonomous Release at I-MGCF

← SIP Response	Trigger event	REL → cause parameter
484 Address Incomplete	Determination that insufficient digits received.	Not sent.
480 Temporarily Unavailable	Congestion at the MGCF/Call is not routable.	Not sent.
BYE	ISUP/BICC procedures result in release after answer	According to ISUP/BICC procedures.
BYE	SIP procedures result in release after answer.	127 (Interworking unspecified)
503 Service Unavailable	Call release due to the ISUP/BICC compatibility procedure (Note)	According to ISUP/BICC procedures.
FFS	Call release due to expiry of T7 within the ISUP/BICC procedures	According to ISUP/BICC procedures.
Note: MGCF receives unrecognised ISUP or BICC signalling information and determines that the call needs to be released based on the coding of the compatibility indicators, refer to ITU-T Q.764 [4] and ITU-T Q.1902.4 [30].		

7.2.3.1.11 Internal through connection of the bearer path

The through connection procedure is described in section 9.2.3.3.

7.2.3.2 Outgoing Call Interworking from BICC/ISUP to SIP at O-MGCF

7.2.3.2.1 Sending of INVITE

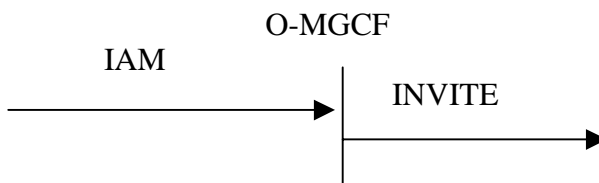

Figure 12: Receipt of an IAM (En bloc signalling in CS network)

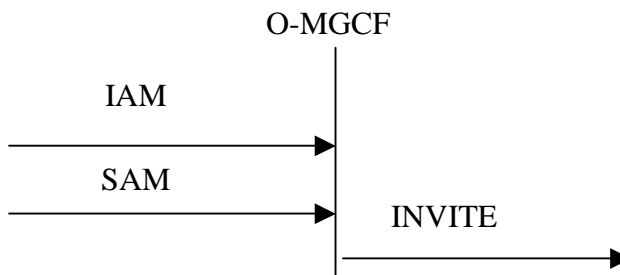

Figure 13: Receipt of an IAM (Overlap signalling in CS network)

After initiating the normal incoming BICC/ISUP call establishment procedures, determining the end of address signalling and selecting to route the call to the IMS domain, the O-MGCF shall send the initial INVITE with pre-conditions. Only calls with Transmission Requirements of speech or 3.1kHz audio will be routed to the IMS domain, all other types of call attempts will be rejected.

The end of address signalling shall be determined:

- a) by receipt of an end-of-pulsing (ST) signal; or
- b) by receipt of the maximum number of digits used in the national numbering plan; or
- c) by analysis of the called party number to indicate that a sufficient number of digits has been received to route the call to the called party; or
- d) by observing that timer T_i/w_1 has expired after the receipt of the latest address message and the minimum number of digits required for routing the call have been received.

7.2.3.2.2 Coding of the INVITE

7.2.3.2.2.1 REQUEST URI Header

The called party number parameter of the IAM message is used to derive Request URI of the INVITE Request. The Request URI is a tel URL and shall contain an International public telecommunication number prefixed by a "+" sign (e.g. tel:+4911231234567).

7.2.3.2.2.2 SDP Media Description

Depending on the coding of the continuity indicators different precondition information (RFC 3312 [37]) is included. If the continuity indicator indicates "continuity performed on a previous circuit" or "continuity required on this circuit", then the O-MGCF shall indicate that the precondition is not met, otherwise the MGCF shall indicate that the precondition is met.

The O-MGCF shall include the AMR codec transported according to RFC 3267 [23] with the options listed in Clause 5.1.1 of 3GPP TS 26.236 [32] in the SDP offer.

7.2.3.2.3

P-Asserted-Identity, From and Privacy header fields

Table 11: Mapping BICC/ISUP CLI Parameters to SIP Header fields

Has a Calling Party Number parameter with complete E.164 number, with Screening Indicator = UPVP or NP (See Note 1), and with APRI = "presentation allowed" or "presentation restricted" been received?	Has a Generic Number (additional calling party number) with a complete E.164 number, with Screening Indicator = UPNV, and with APRI = "presentation allowed" been received?	P-Asserted-Identity header field	From header field:	Privacy header field
N	N	Header field not included	SIP or SIPS URI with addr spec "unavailable@anonymous.invalid" (Note 2)	Header field not included
Y (Note 1)	N	Derived from Calling Party Number parameter address signals (See Table 13)	if APRI = "allowed", Tel URL derived from Calling Party Number parameter address signals (See Table 14) if APRI = "restricted", SIP or SIPS URI with addr spec "anonymous@anonymous.invalid" (Note 2)	If Calling Party Number parameter APRI = "restricted" then priv-value =: "id". For other APRI settings Privacy header is not included or if included, "id" is not included (See Table 15)
Y	Y	Derived from Calling Party Number parameter address signals (See Table 13)	derived from Generic Number (ACgPN) address signals (See Table 12) derived from Generic Number (ACgPN) address signals (See Table 12)	If Calling Party Number parameter APRI = "restricted" then priv-value =: "id". For other APRI settings Privacy header is not included or if included, "id" is not included (See Table 15)

Table 12: Mapping of Generic Number (additional calling party number) to SIP From header fields

BICC/ISUP Parameter / field	Value	SIP Component	Value
Generic Number Number Qualifier Indicator	"additional calling party number"	From header field	display-name (optional) and addr-spec
Nature of Address Indicator	"national (significant) number"	Tel URL	Add CC (of the country where the MGCF is located) to GN address signals to construct E.164 number in URI. Prefix number with "+".
	"international number"		Map complete GN address signals to E.164 number in URI. Prefix number with "+".
Address signal	if NOA is "national (significant) number" then the format of the address signals is:		

BICC/ISUP Parameter / field	Value	SIP Component	Value
	NDC+ SN If NOA is " <i>international number</i> " then the format of the address signals is: CC + NDC + SN	Tel URL	CC+NDC+SN as E.164 number in URI. Prefix number with "+".

Table 13: Mapping of Calling Party Number parameter to SIP P-Asserted-Identity header fields

BICC/ISUP Parameter / field	Value	SIP Component	Value
Calling Party Number		P-Asserted-Identity header field	
Nature of Address Indicator	" <i>national (significant) number</i> "	Tel URL	Add CC (of the country where the MGCF is located) to CgPN address signals to construct E.164 number in URI. Prefix number with "+".
	" <i>international number</i> "		Map complete CgPN address signals to E.164 number in URI. Prefix number with "+".
Address signal	If NOA is " <i>national (significant) number</i> " then the format of the address signals is: NDC + SN If NOA is " <i>international number</i> " then the format of the address signals is: CC + NDC + SN		

Table 14: Mapping of BICC/ISUP Calling Party Number parameter to SIP From header fields

BICC/ISUP Parameter / field	Value	SIP Component	Value
Calling Party Number		From header field	
Nature of Address Indicator	<i>"national (significant) number"</i>	Tel URL	Add CC (of the country where the MGCF is located) to CgPN address signals then map to construct E.164 number in URI. Prefix number with "+".
	<i>"international number"</i>		Map complete CgPN address signals to construct E.164 number in URI. Prefix number with "+".
Address signal	If NOA is <i>"national (significant) number"</i> then the format of the address signals is: NDC + SN If NOA is <i>"international number"</i> then the format of the address signals is: CC + NDC + SN		
		Tel URL	CC+NDC+SN as E.164 number in URI. Prefix number with "+".

Table 15: Mapping of BICC/ISUP APRI into SIP Privacy header fields

BICC/ISUP Parameter / field	Value	SIP Component	Value
Calling Party Number		Privacy header field	priv-value
APRI (See to determine which APRI to use for this mapping)	<i>"presentation restricted"</i>	Priv-value	"id" ("id" included only if the P-Asserted-Identity header is included in the SIP INVITE)
	<i>"presentation allowed"</i>	Priv-value	omit Privacy header or Privacy header without "id" if other privacy service is needed
Note:	When Calling Party Number parameter exists, P-Asserted-Identity header is always derived from it as in Table 13.		

7.2.3.2.2.4 Max Forwards header

If the Hop Counter procedure is supported in the CS network, the O-MGCF shall use the Hop Counter parameter to derive the Max-Forwards SIP header. Due to the different default values (that are based on network demands/provisions) of the SIP Max-Forwards header and the Hop Counter, an adaptation mechanism shall be used to adopt the Hop Counter to the Max Forwards at the O-MGCF. For example, the following guidelines could be applied.

- a) Max-Forwards for a given message should be monotone decreasing with each successive visit to a SIP entity, regardless of intervening interworking, and similarly for Hop Counter.
- b) The initial and successively mapped values of Max-Forwards should be large enough to accommodate the maximum number of hops that may be expected of a validly routed call.

The table 16 shows the principle of the mapping:

Table 16: Hop counter-Max forwards

Hop Counter	= Y	Max-Forwards	= X
Note: The Mapping of value X to Y should be done with the used (implemented) adaptation mechanism.			

The Principle of adaptation could be implemented on a basis of the network provision, trust domain rules and bilateral agreement.

7.2.3.2.3 Sending of UPDATE

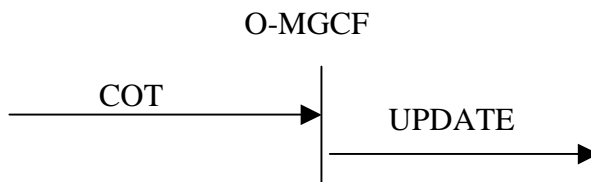

Figure 14: Receipt of COT.

When the requested preconditions in the IMS have been met and outstanding continuity procedures successfully completed the UPDATE is sent confirming that all the required preconditions have been met.

7.2.3.2.4 Sending of ACM and Awaiting Answer indication

The following cases are possible trigger conditions that shall lead to the sending the address complete message (ACM).

The sending of an awaiting answer indication is described in subclause 9.2.3.3

- The detection of end of address signalling by the expiry of Timer T i/w₁ or,

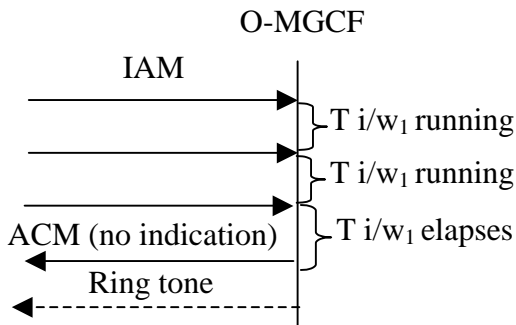

Figure 15: Sending of ACM T i/w₁ elapses

- The reception of 180 Ringing or,

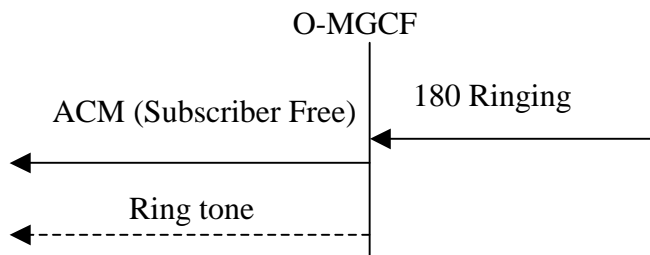

Figure 16: Sending of ACM (Receipt of 180 ringing)

- 4-6 seconds (T_{i/w 2}) after the initial INVITE is sent

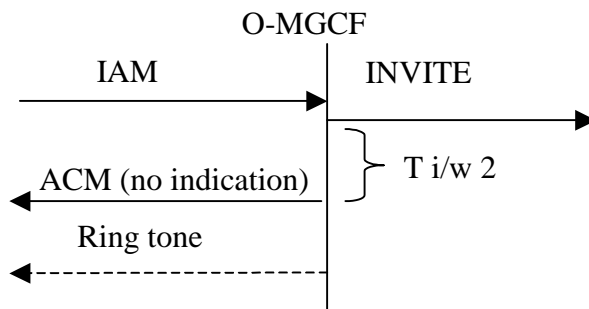

Figure 17: Sending of ACM (T_{i/w 2} elapses)

NOTE: In all cases, it is assumed that no Address Complete Message (ACM) has already been sent.

7.2.3.2.5 Coding of the ACM

The description of the following ISDN user part parameters can be found in ITU-T Q.763 [4].

7.2.3.2.5.1 Backward call indicators

bits	AB	Charge indicator Contributors
	1 0	<i>charge</i>
bits	DC	Called party's status indicator
	0 1	<i>subscriber free</i> if the 180 Ringing has been received.
	0 0	<i>no indication</i> otherwise
bits	FE	Called party's category indicator
	0 0	<i>no indication</i>
bits	HG	End-to-end method indicator
	0 1	<i>no end-to-end method available</i>
bit	I	Interworking indicator
	1	<i>interworking encountered</i>
bit	J	End-to-end information indicator
	0	<i>no end-to-end information available</i>
bit	K	ISDN user part/BICC indicator
	0	<i>ISDN user part not used all the way</i>
bit	L	Holding indicator (national use)
	0	<i>holding not requested</i>
bit	M	ISDN access indicator
	0	<i>terminating access non-ISDN</i>

7.2.3.2.6 Sending of the Call Progress message (CPG)

If the Address Complete Message (ACM) has already been sent, the following cases are possible trigger conditions for sending the Call Progress message (CPG):

- Receipt of the first the 180 Ringing

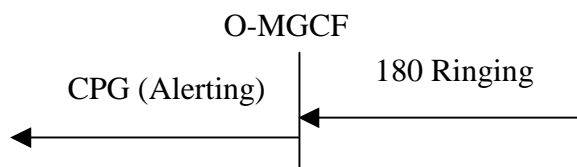

Figure 18: Sending of CPG

7.2.3.2.7 Coding of the CPG

The description of the following ISDN user part parameters can be found in ITU-T Q.763 [4].

7.2.3.2.7.1 Event information

bits	G-A	Event indicator
------	-----	-----------------

0 0 0 0 0 0 1 *alerting*

7.2.3.2.8 Sending of the Answer Message (ANM)

- a) Upon receipt of the first 200 OK (INVITE), if the address complete message has already been sent, the interworking exchange shall send the Answer Message (ANM) to the preceding exchange.

Note: Through connection and the stop of awaiting answer indication are described in section 9.2.3.3

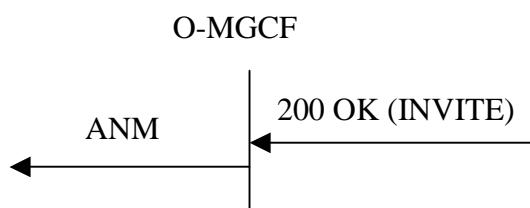

Figure 19: Sending of ANM

7.2.3.2.9 Coding of the ANM

7.2.3.2.9.1 Backwards Call Indicators

If Backwards Call Indicators are included in the ANM, then the coding of these parameters is described in clause 7.2.3.2.5.1.

7.2.3.2.10 Sending of the Connect message (CON)

Upon receipt of the first 200 OK (INVITE), if the Address Complete Message (ACM) has not yet been sent, send the Connect message (CON) to the preceding exchange.

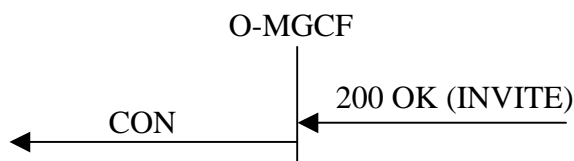

Figure 20: Sending of CON

7.2.3.2.11 Coding of the CON

The description of the following ISDN user part parameters can be found in ITU-T Q.763 [4].

7.2.3.2.11.1 Backward call indicators

The Called Party's status indicator (Bit DC) of BCI parameter is set to "no indication". The other BCI indicators shall be set as described in clause 7.2.3.2.5.1

7.2.3.2.12 Receipt of Status Codes 4xx, 5xx or 6xx

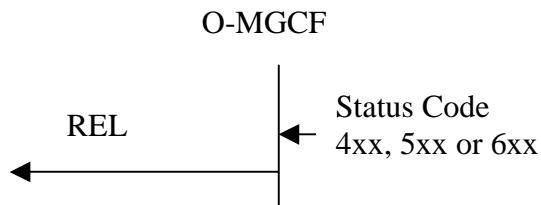

Figure 21: Receipt of Status codes 4xx, 5xx or 6xx

When receiving SIP response with status codes 4xx, 5xx or 6xx, the O-MGCF shall send a REL message. The coding of the Cause parameter value in the REL message is derived from the SIP Status code received according to Table 17. The Cause Parameter Values are defined in ITU-T Q.850 [38].

Table 17: 4xx/5xx/6xx Received on SIP side of O-MGCF

←REL (cause code)	←4xx/5xx/6xx SIP Message
127 (interworking unspecified)	400 Bad Request
127 (interworking unspecified)	401 Unauthorised
127 (interworking unspecified)	402 Payment Required
127 (interworking unspecified)	403 Forbidden
1 (Unallocated number)	404 Not Found
127 (interworking unspecified)	405 Method Not Allowed
127 (interworking unspecified)	406 Not Acceptable
127 (interworking unspecified)	407 Proxy authentication required
127 (interworking unspecified)	408 Request Timeout
22 (Number changed)	410 Gone
127 (interworking unspecified)	413 Request Entity too long
127 (interworking unspecified)	414 Request-URI too long
127 (interworking unspecified)	415 Unsupported Media type
127 (interworking unspecified)	416 Unsupported URI scheme
127 (interworking unspecified)	420 Bad Extension
127 (interworking unspecified)	421 Extension required
127 (interworking unspecified)	423 Interval Too Brief
18 (No user responding)	480 Temporarily Unavailable
127 (interworking unspecified)	481 Call/Transaction does not exist
127 (interworking unspecified)	482 Loop detected
127 (interworking unspecified)	483 Too many hops
28 (Invalid Number format)	484 Address Incomplete

←REL (cause code)	←4xx/5xx/6xx SIP Message
127 (interworking unspecified)	485 Ambiguous
17 (User busy)	486 Busy Here
No mapping	487 Request terminated
127 (interworking unspecified)	488 Not acceptable here
127 (interworking unspecified)	490 Request Updated
127 (interworking unspecified)	"491" ; Request Pending
127 (interworking unspecified)	493 Undecipherable
127 (interworking unspecified)	500 Server Internal error
127 (interworking unspecified)	501 Not implemented
127 (interworking unspecified)	502 Bad Gateway
127 (interworking unspecified)	503 Service Unavailable
127 (interworking unspecified)	504 Server timeout
127 (interworking unspecified)	505 Version not supported
127 (interworking unspecified)	513 Message too large
127 (interworking unspecified)	580 Precondition failure
17 (User busy)	600 Busy Everywhere
21 (Call rejected)	603 Decline
1 (unallocated number)	604 Does not exist anywhere
127 (interworking unspecified)	606 Not acceptable

7.2.3.2.13 Receipt of a BYE

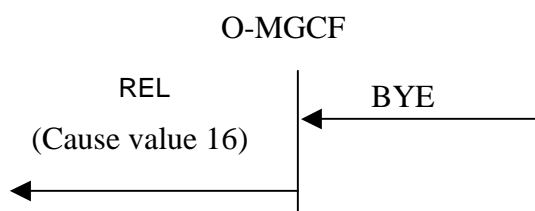

Figure 22: Receipt of BYE method

On receipt of a BYE method, the O-MGCF sends a REL message with Cause Code value 16 (Normal Call Clearing).

7.2.3.2.14 Receipt of the Release Message

In the case that the REL message is received and a final response (i.e. 200 OK (INVITE)) has already been received the O-MGCF shall send a BYE method. If the final response (i.e. 200 OK (INVITE)) has not already been received the O-MGCF shall send a CANCEL method.

7.2.3.2.15 Receipt of RSC, GRS or CGB (H/W oriented)

If a RSC, GRS or CGB (H/W oriented) message is received and a final response (i.e. 200 OK (INVITE)) has already been received the O-MGCF shall send a BYE method. If a final response (i.e. 200 OK (INVITE)) has not already been received the O-MGCF shall send a CANCEL method.

7.2.3.2.16 Autonomous Release at O-MGCF

If the O-MGCF determines due to internal procedures that the call shall be released then the MGCF shall send

- A BYE method if the ACK has been sent.
- A CANCEL method before 200 OK (INVITE) has been received.

NOTE: The MGCF shall send the ACK method before it sends the BYE, if 200 OK (INVITE) is received.

7.2.3.2.17 Special handling of 580 Precondition failure received in response to either an INVITE or UPDATE

A 580 Precondition failure response may be received as a response either to an INVITE or to an UPDATE request.

7.2.3.2.17.1 580 Precondition failure response to an INVITE.

Release with cause code as indicated in Table 17 is sent immediately to the BICC/ISUP network.

7.2.3.2.17.2 580 Precondition failure response to an UPDATE within an early dialog

Release with Cause Code '127 Interworking' is sent immediately to the BICC/ISUP network. A BYE request is sent for the INVITE transaction within which the UPDATE was sent.

7.2.3.3 Timers

Table 18: Timers for interworking

Symbol	Time-out value	Cause for initiation	Normal termination	At expiry	Reference
Ti/w1	4-6 seconds (default of 4 seconds)	When last address message is received in interworking situations.	At the receipt of fresh information.	Send INVITE, send the address complete message and insert ring tone	7.2.3.2.1 7.2.3.2.4
Ti/w2	4-6 seconds (default of 4 seconds)	When latest address message is received in interworking situations.	When ACM is sent.	Send address complete message and insert ring tone	7.2.3.2.4

7.3 Interworking between CS networks supporting BICC and the IM CN subsystem

The control plane between CS networks supporting BICC and the IM CN subsystem supporting SIP, where the underlying network is SS7 and IP respectively is as shown in Figure 23, 24 and 25.

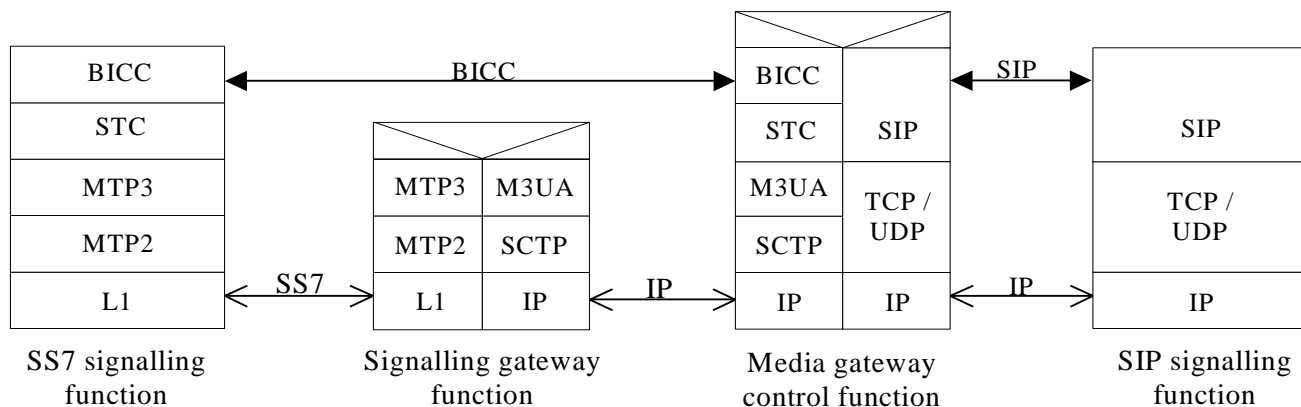

Figure 23: Control Plane interworking between CS networks supporting BICC over MTP3 and the IM CN subsystem

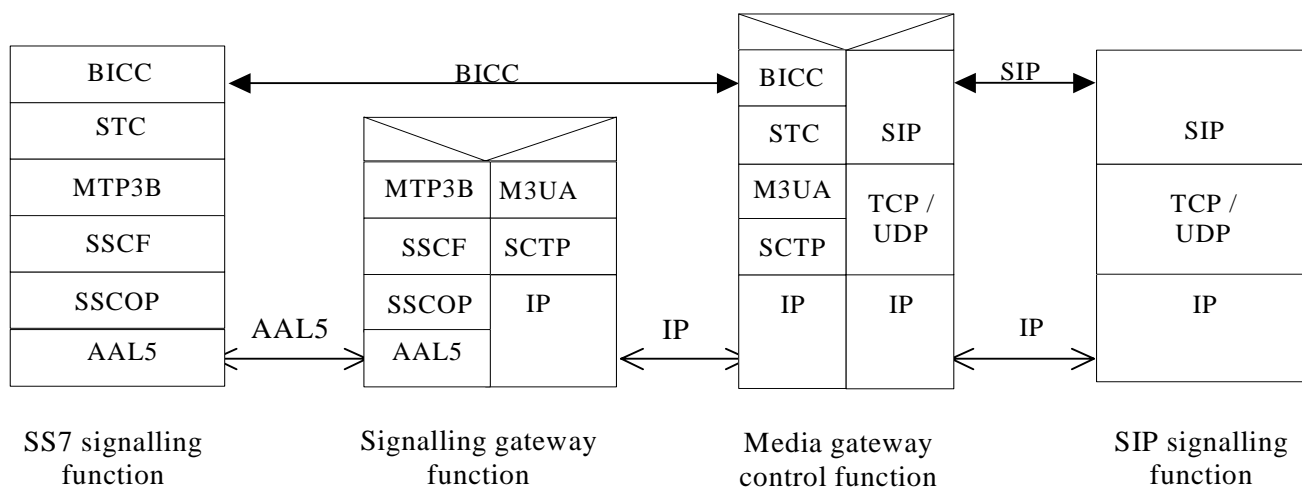

Figure 24: Control Plane interworking between CS networks supporting BICC over MTP3B over AAL5 and the IM CN subsystem

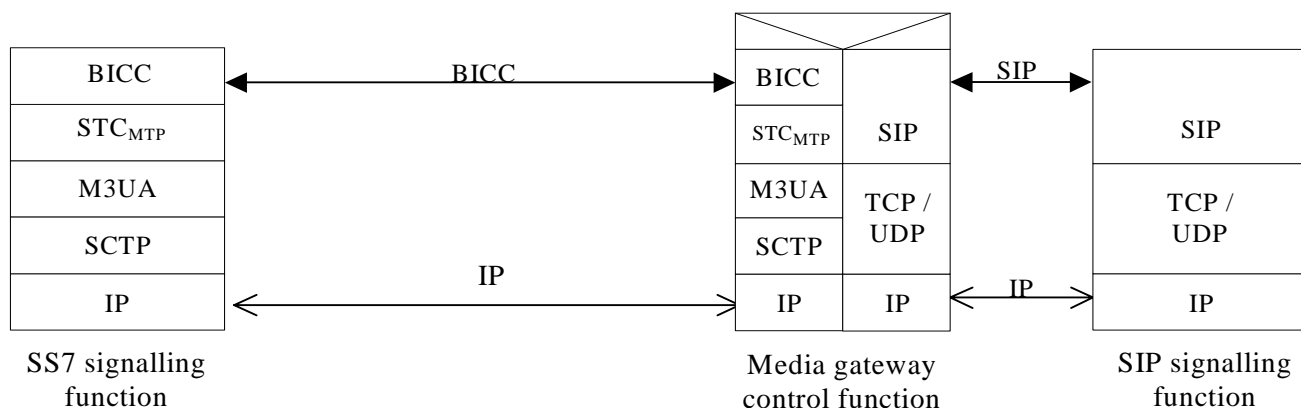

Figure 25: Control Plane interworking between CS networks supporting BICC over STC and M3UA and the IM CN subsystem

7.3.1 Services performed by network entities in the control plane

Services offered by the network entities in the control plane are as detailed in Subclause 7.2.1.

If ATM transport is applied between the SS7 Signalling function and the Signalling Gateway Function, they shall apply MTP3B (ITU-T Q.2210 [46]) over SSCF (ITU-T Q.2140 [45]) over SSCOP (ITU-T Q.2110 [44]) over AAL5 (ITU-T I.363.6 [43]) as depicted in Figure 24.

If IP transport is applied between the SS7 Signalling function and the MGCF, the SS7 Signalling function shall support and apply M3UA, SCTP and IP, as depicted in Figure 25.

7.3.2 Signalling interactions between network entities in the control plane

7.3.2.1 Signalling between the SS7 signalling function and MGCF

See Subclause 7.2.2.1

7.3.2.1.1 Signalling from MGCF to SS7 signalling function

See Subclause 7.2.2.1.1

7.3.2.1.2 Signalling from SS7 signalling function to MGCF

See Subclause 7.2.2.1.2.

7.3.2.1.3 Services offered by STC, SCTP and M3UA

See Subclause 7.2.2.1.3

7.3.2.1.3.1 Services offer by SCTP

See Subclause 7.2.2.1.3.1

7.3.2.1.3.2 Services offered by M3UA

See Subclause 7.2.2.1.3.2

7.3.2.1.3.3 Services offered by STC

STC provides the services for the transparent transfer of STC user information, e.g. BICC, between STC users, i.e. the SS7 signalling function and the MGCF (see 3GPP TS 29.205 [14]).

STC performs the functions of data transfer service availability reporting and congestion reporting to the STC user and User part availability control. See ITU-T Q.2150.1 [29].

7.3.2.2 Signalling between the MGCF and SIP signalling function

See Subclause 7.2.2.2

7.3.3 SIP-BICC protocol interworking

7.3.3.1 Incoming Call Interworking from SIP to BICC/ISUP at I-MGCF

7.3.3.1.1 Sending of IAM

On reception of the INVITE requesting an audio session, the I-MGCF shall send the IAM.

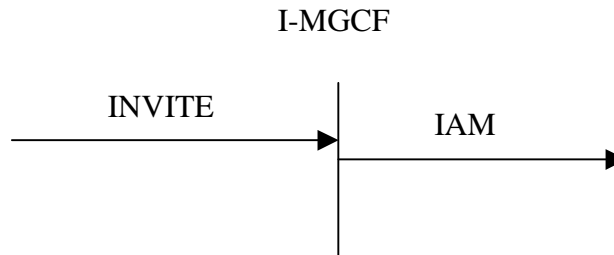

Figure 26: receipt of Invite

7.3.3.1.2 Coding of IAM

The description of the following ISDN user part parameters can be found in ITU-T Q.763 [4].

7.3.3.1.2.1 Called Party Number

See Subclause 7.2.3.1.2.1

7.3.3.1.2.2 Nature of connection indicators

bits	<u>BA</u>	Satellite indicator
	0 1	one satellite circuit in the connection
bits	<u>DC</u>	Continuity indicator (BICC)
	1 0	COT to be expected
bit	<u>E</u>	Echo control device indicator
	1	outgoing echo control device included

7.3.3.1.2.3 Forward call indicators

See Subclause 7.2.3.1.2.3

7.3.3.1.2.4 Calling party's category

See Subclause 7.2.3.1.2.4

7.3.3.1.2.5 Transmission medium requirement

See Subclause 7.2.3.1.2.5

7.3.3.1.2.6 Calling party number

See Subclause 7.2.3.1.2.6

7.3.3.1.2.7 Generic number

See Subclause 7.2.3.1.2.7

7.3.3.1.2.8 User service information

See Subclause 7.2.3.1.2.8

7.3.3.1.2.9 Hop counter (National option)

See Subclause 7.2.3.1.2.9

7.3.3.1.3 Sending of COT

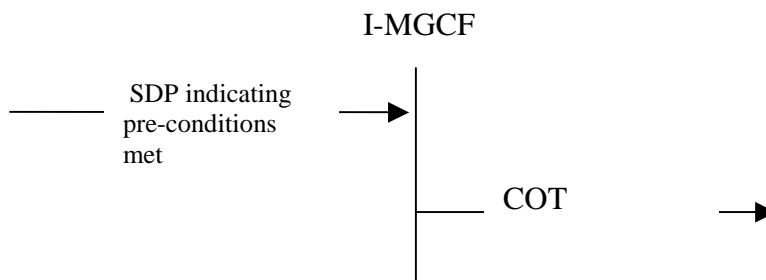

Figure 27: Sending of COT

When the requested preconditions in the SIP network have been met, the IAM has already been sent, then the Continuity message shall be sent indicating “successful”.

7.3.3.1.4 Sending of 180 Ringing

See Subclause 7.2.3.1.4

7.3.3.1.5 Sending of the 200 OK (INVITE)

See Subclause 7.2.3.1.5

7.3.3.1.6 Sending of the Release message (REL)

See Subclause 7.2.3.1.6

7.3.3.1.7 Coding of the REL

See Subclause 7.2.3.1.7

7.3.3.1.8 Receipt of the Release Message

See Subclause 7.2.3.1.8

7.3.3.1.9 Receipt of RSC, GRS or CGB (H/W oriented)

See Subclause 7.2.3.1.9

7.3.3.1.10 Internal through connection of the bearer path

The I-MGCF will through connect the internal switch path in both directions when:

- the requested preconditions in the IMS have been met, and
- the bearer set-up procedure is successfully completed.

7.3.3.1.11 Out of Band DTMF

If a SIP UA sends DTMF tones the IM-MGW receives this information. This information may be transported via the Mn interface to the MGCF. In this case the MGCF shall use the APM message with the following values on the different parameters:

- Action indicator in accordance with the requested DTMF transport function
- Signal in accordance with which DTMF digit to send

- Duration in accordance with the required duration of the DTMF digit.

The interaction with the IM-MGW is shown in subclause 9.2.7.

7.3.3.2 Outgoing Call Interworking from BICC/ISUP to SIP at O-MGCF

7.3.3.2.1 Sending of INVITE

See Subclause 7.2.3.2.1

7.3.3.2.2 Coding of the INVITE

7.3.3.2.2.1 REQUEST URI Header

See Subclause 7.2.3.2.2.1

7.3.3.2.2.2 SDP Media Description

The O-MGCF shall indicate that precondition is not met.

The O-MGCF shall include the AMR codec transported according to RFC 3267 [23] with the options listed in Clause 5.1.1 of 3GPP TS 26.236 [32] in the SDP offer.

7.3.3.2.2.3 P-Asserted-Identity and privacy header fields

See Subclause 7.2.3.2.2.3

7.3.3.2.2.4 Max Forwards header

See Subclause 7.2.3.2.2.4

7.3.3.2.3 Sending of UPDATE

See Subclause 7.2.3.2.3

7.3.3.2.4 Sending of ACM and Awaiting Answer indication

See Subclause 7.2.3.2.4

The sending of an awaiting answer indication is described in section 9.2.3.1. and 9.2.3.2.

7.3.3.2.5 Coding of the ACM

7.3.3.2.5.1 Backward call indicators

See Subclause 7.2.3.2.5.1

7.3.3.2.6 Sending of the Call Progress message (CPG)

See Subclause 7.2.3.2.6

7.3.3.2.7 Coding of the CPG

7.3.3.2.7.1 Event information

See Subclause 7.2.3.2.7.1

7.3.3.2.8 Sending of the Answer Message (ANM)

See Subclause 7.2.3.2.8

7.3.3.2.9 Coding of the ANM

See Subclause 7.2.3.2.9

7.3.3.2.10 Sending of the Connect message (CON)

See Subclause 7.2.3.2.10

7.3.3.2.11 Coding of the CON

See Subclause 7.2.3.2.11

7.3.3.2.11.1 Backward call indicators

See Subclause 7.2.3.2.11.1

7.3.3.2.12 Receipt of Status Codes 4xx, 5xx or 6xx

See Subclause 7.2.3.2.12.

7.3.3.2.13 Receipt of a BYE

See Subclause 7.2.3.2.13

7.3.3.2.14 Receipt of the Release Message

See Subclause 7.2.3.2.14

7.3.3.2.15 Receipt of RSC, GRS or CGB (H/W oriented)

See Subclause 7.2.3.2.15.

7.3.3.2.16 Out of Band DTMF

If a SIP UA sends DTMF tones the IM-MGW receives this information. This information may be transported via the Mn interface to the MGCF. In this case the MGCF shall use the APM message with the following values on the different parameters

- Action indicator in accordance with the requested DTMF transport function
- Signal in accordance with which DTMF digit to send
- Duration in accordance with the required duration of the DTMF digit.

The interaction with the IM-MGW is shown in subclause 9.2.7.

7.3.3.3 Timers

See Subclause 7.2.3.3

7.4 Supplementary services

The following sub-clauses describe the MGCF behaviour related to supplementary services as defined in [ITU-T Q.73X series recommendation](#).

7.4.1 Calling line identification presentation/restriction (CLIP/CLIR)

The inter working between the Calling Party Number parameter and the P-Asserted-ID header and vice versa used for the CLIP-CLIR service is defined in the clauses 7.2.3.1.2.6 and 7.2.3.2.2.6. This inter working is essentially the same as for basic call and differs only in that if the CLIR service is invoked the "Address Presentation Restriction Indicator (APRI)" (in the case of ISUP to SIP calls) or the "priv value" of the "calling" Privacy header field (in the case of SIP to ISUP calls) is set to the appropriate "restriction/privacy" value.

In the specific case of ISUP originated calls, use of the CLIP service additionally requires the ability to determine whether the number was network provided or provided by the access signalling system. Due to the possible SIP indication of the P-Asserted-Identity the Screening indicator is set to network provided as default. For the CLIP-CLIR service the mapping of the APRI from privacy header at the O-MGCF is described within Table 15 in Subclause 7.2.3.2.2.6.

At the O-MGCF the presentation restricted indication shall be mapped to the privacy header = "id" and "header". This is described in Table 5 in Subclause 7.2.3.1.2.6.

7.4.2 Connected line presentation and restriction (COLP/COLR)

The service is not interworked.

7.4.3 Direct dialling in

The service is not interworked.

7.4.4 Malicious call identification

The service is not interworked.

7.4.5 Sub-addressing (SUB)

The service is not interworked.

7.4.6 Call Forwarding Busy (CFB)/ Call Forwarding No Reply (CFNR) / Call Forwarding Unconditional (CFU)

The service is not interworked.

7.4.7 Call Deflection (CD)

The service is not interworked.

7.4.8 Explicit Call Transfer (ECT)

The service is not interworked.

7.4.9 Call Waiting

The service is not interworked.

7.4.10 Call Hold

The service is not interworked.

7.4.11 Call Completion on busy subscriber

The service is not interworked.

7.4.12 Completion of Calls on No Reply (CCNR)

The service is not interworked.

7.4.13 Terminal Portability (TP)

The service is not interworked.

7.4.14 Conference calling (CONF)

The service is not interworked.

7.4.15 Three-Party Service (3PTY)

The service is not interworked.

7.4.16 Closed User Group (CUG)

The service is not interworked.

7.4.17 Multi-Level Precedence and Preemption (MLPP)

The service is not interworked.

7.4.18 Global Virtual Network Service (GVNS)

The service is not interworked.

7.4.19 International telecommunication charge card (ITCC)

The service is not interworked. AN ITCC call is a basic call and no additional treatment is required by the MGCF.

7.4.20 Reverse charging (REV)

The service is not interworked.

7.4.21 User-to-User Signalling (UUS)

The service is not interworked.

8 User Plane Interworking

8.1 Interworking between IM CN subsystem and bearer independent CS network

When the IM CN subsystem interworks with the bearer independent CS networks (e.g. CS domain of a PLMN, 3GPP TS 29.414 [25], 3GPP TS 29.415 [26], 3GPP TS 23.205 [27]), the transport network layer (TNL) of the bearer independent CS network can be based e.g. on IP/UDP/RTP, or IP/UDP/RTP/IuFP, or ATM/AAL2/ framing protocol (e.g. Iu framing) transport techniques. Figure 28 shows the user plane protocol stacks for the IM CS subsystem and bearer independent CS network interworking.

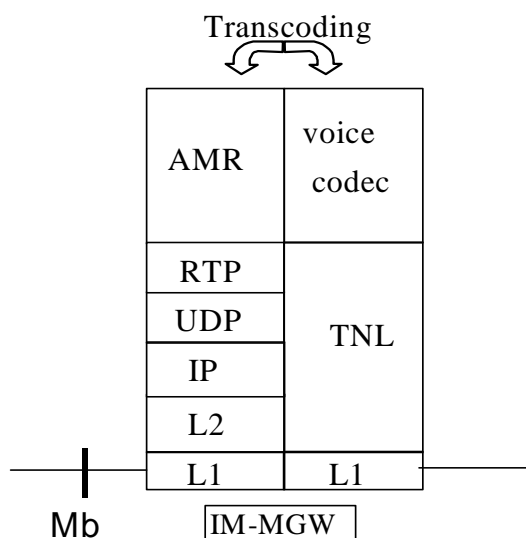

Figure 28: IM CN subsystem to bearer independent CS Network User Plane Protocol Stack

8.2 Interworking between IM CN subsystem and TDM-based CS network

It shall be possible for the IM CN subsystem to interwork with the TDM based CS networks (e.g. PSTN, ISDN or CS domain of a PLMN). Figure 29 describes the user plane protocol stack to provide the particular interworking.

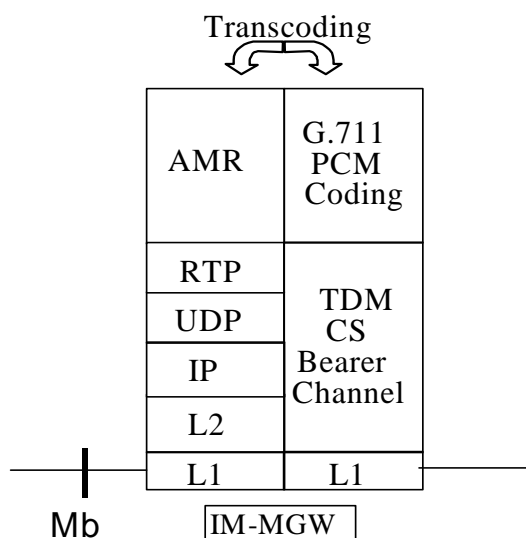

Figure 29: IM CN subsystem to TDM-based CS Network User Plane Protocol Stack

8.3 Transcoding requirements

The IM CN subsystem supports the AMR codec as the native codec for basic voice services. For IM CN subsystem terminations, the IM MGW shall support the transport of AMR over RTP according to RFC 3267 [23]. The MGCF shall support the options of RFC 3267 listed within Clause 5.1.1 of 3GPP TS 26.236 [32].

It shall be possible for the IM CN subsystem to interwork with the CS networks (e.g. PSTN, ISDN or a CS domain of a PLMN) by supporting AMR to G.711 transcoding (see ITU G.711 [1]) in the IM-MGW. The IM-MGW may also perform transcoding between AMR and other codec types supported by CS networks.

8.4 Diffserv Code Point requirements

The IM-MGW shall perform DiffServ Code Point (DSCP) markings (see RFC 2474 [21]) on the IP packets sent towards the IM CN subsystem entity like UE or MRFP across the Mb interface to allow DiffServ compliant routers and GGSNs to schedule the traffic accordingly.

The IETF Differentiated Services architecture (see RFC 2475 [22]) shall be used to provide QoS for the external bearer service.

The DSCP shall be operator configurable.

9 MGCF – IM-MGW Interaction

9.1 Overview

The MGCF shall control the functions of the IM-MGW, which are used to provide the connection between media streams of an IP based transport network and bearer channels from a CS network.

The MGCF shall interact with the IM-MGW across the Mn reference point. The MGCF shall terminate the signalling across the Mn interface towards the IM-MGW and the IM-MGW shall terminate the signalling from the MGCF.

The signalling interface across the Mn reference point shall be defined in accordance with ITU-T H.248 [2] and shall conform to 3GPP specific extensions as detailed in 3GPP TS 29.332 [15].

The present specification describes Mn signalling procedures and their interaction with BICC/ISUP and SIP signalling in the control plane, and with user plane procedures. 3GPP TS 29.332 [15] maps these signalling procedures to H.248 messages and defines the required packages and parameters.

9.2 Mn Signalling Interactions

The following paragraphs describe the Mn interface procedures triggered by SIP and BICC signalling relayed in MGCF.

The SIP signalling occurring at the MGCF is described in 3GPP TS 24.229 [9].

All message sequence charts in this clause are examples.

9.2.1 Network Model

Figure 30 shows the network model, applicable to BICC and ISUP cases. The broken line represents the call control signalling. The dotted line represents the bearer control signalling (if applicable) and the user plane. The MGCF uses one context with two terminations in the IM-MGW. The termination T1 is used towards the IM CN subsystem entity and the bearer termination T2 is used for the bearer towards the succeeding CS network element.

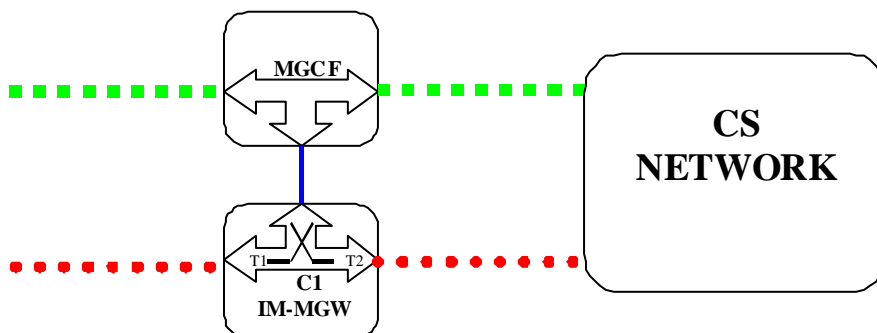

Figure 30: Network model

9.2.2 Basic IM CN Subsystem originated Session

9.2.2.1 BICC Forward bearer establishment

9.2.2.1.1 IM-MGW selection

The MGCF shall select an IM-MGW for the bearer connection before it performs the CS network side bearer establishment. This may happen either before sending the IAM or after receiving the APM message (signal 5 or signal 6 in Figure 31). In the latter case, the IM-MGW selection may be based on a possibly received MGW-id from the succeeding node.

9.2.2.1.2 CS network side bearer establishment

The MGCF shall either select bearer characteristics or request the IM-MGW to select and provide the bearer characteristics for the CS network side bearer connection before sending the IAM. In the latter case the MGCF shall use the Prepare Bearer procedure, not shown in Figure 31, to request the IM-MGW to select the bearer characteristics. After the succeeding node has provided a bearer address and a binding reference in the APM, the MGCF shall use the Establish Bearer procedure to request the IM-MGW to establish a bearer towards the destination CS-MGW. The MGCF shall provide the IM-MGW with the bearer address, the binding reference and the bearer characteristics (signal 7 in Figure 31).

9.2.2.1.3 IM CN subsystem side termination reservation

On receipt of INVITE (signal 1 in figure 31) the MGCF shall initiate the Reserve Local and Remote IMS Connection Points procedure (signal 3 and 4 in figure 31). From the received SDP and local configuration data the MGCF

- shall send the appropriate remote Codec(s), codec port(s) and remote IP connection information to the IM-MGW.
- shall indicate the local codec(s) and requests port information for these codec(s) with the reserve value indicator set to “true” (if applicable) and request local IP configuration data.

Note: The reserve value indicator set to “true” is only applicable if DTMF support together with AMR support are required.

The IM-MGW

- shall reply to the MGCF with the local codec - port combinations, local IP configuration data and which of the remote codec(s) it supports
- shall reserve the codec(s)

The MCGF shall take the local codec/ port pairs, the local IP connection information and send it to to the IMS in the Session Progress (signal 9 in Figure 31).

9.2.2.1.4 IM CN subsystem side session establishment

Dependent on what the MGCF receives in PRACK (signal 10 in figure 31) the MGCF may initiate the Select Local and Remote IMS Multimedia Processing Resource procedure. If the received SDP is the same as the SDP sent in signal 9 in figure 31 the procedure is not invoked. Others the MGCF shall use the Select Local and Remote IMS Multimedia Processing Resource procedure to provide to the IM-MGW

- the remote IP configuration information and remote codec and port number to address user data towards the IM CN subsystem
- optionally send the local codec, port information for the codec and the local IP connection data.

Note: This may be triggered if the requirement for DTMF is withdrawn.

The IM-MGW shall update the codec reservation and remote IP configuration data in accordance with the received information.

The MGCF shall include the selected codec(s) and codec number(s) and other IP connection data in an SDP answer (signal 11 in Figure 31) sent back to the IMS.

9.2.2.1.5 Through-Connection

During the Prepare Bearer and Establish Bearer procedures, the MGCF shall either use the Change Through-Connection procedure to request the IM-MGW to backward through-connect the BICC terminations, or the MGCF shall use this procedure to both-way through-connect the BICC termination already on this stage (signal 7 in Figure 31). During the Reserve IMS connection Point procedure, the MGCF shall use the Change IMS Through-Connection procedure to request the IM-MGW to backward through-connect the IMS termination (signal 3 in Figure 31).

When the MGCF receives the BICC:ANM answer indication, it shall request the IM-MGW to both-way through-connect the termination using the Change Through-Connection or Change IMS Through-Connection procedures (signal 22 in Figure 31), unless those terminations are already both-way through-connected.

9.2.2.1.6 Codec handling

The IM-MGW may include a speech transcoder based upon the speech coding information provided to each termination.

9.2.2.1.7 Failure handling in MGCF

If any procedure between the MGCF and the IM-MGW is not completed successfully or the MGCF receives a Bearer Released procedure from the IM-MGW, the session shall be cleared as described in Clause 9.2.5, MGCF initiated call clearing or in Clause 9.2.6, IM-MGW initiated call clearing. Alternatively, the MGCF may only release the resources in the IM-MGW that caused the failure, possibly select a new IM-MGW for the connection and continue the call establishment using new resources in the selected IM-MGW.

9.2.2.1.8 Message sequence chart

Figure 31 shows the message sequence chart for the IM CN subsystem originating session when the forward bearer establishment is used. In the chart The MGCF requests seizure of IM CN subsystem side termination. After that .the MGCF requests seizure of the CS network side bearer termination and establishment of the bearer when the APM is received from the succeeding node. When the MGCF receives an answer indication, it requests the IM-MGW to both-way through-connect the terminations.

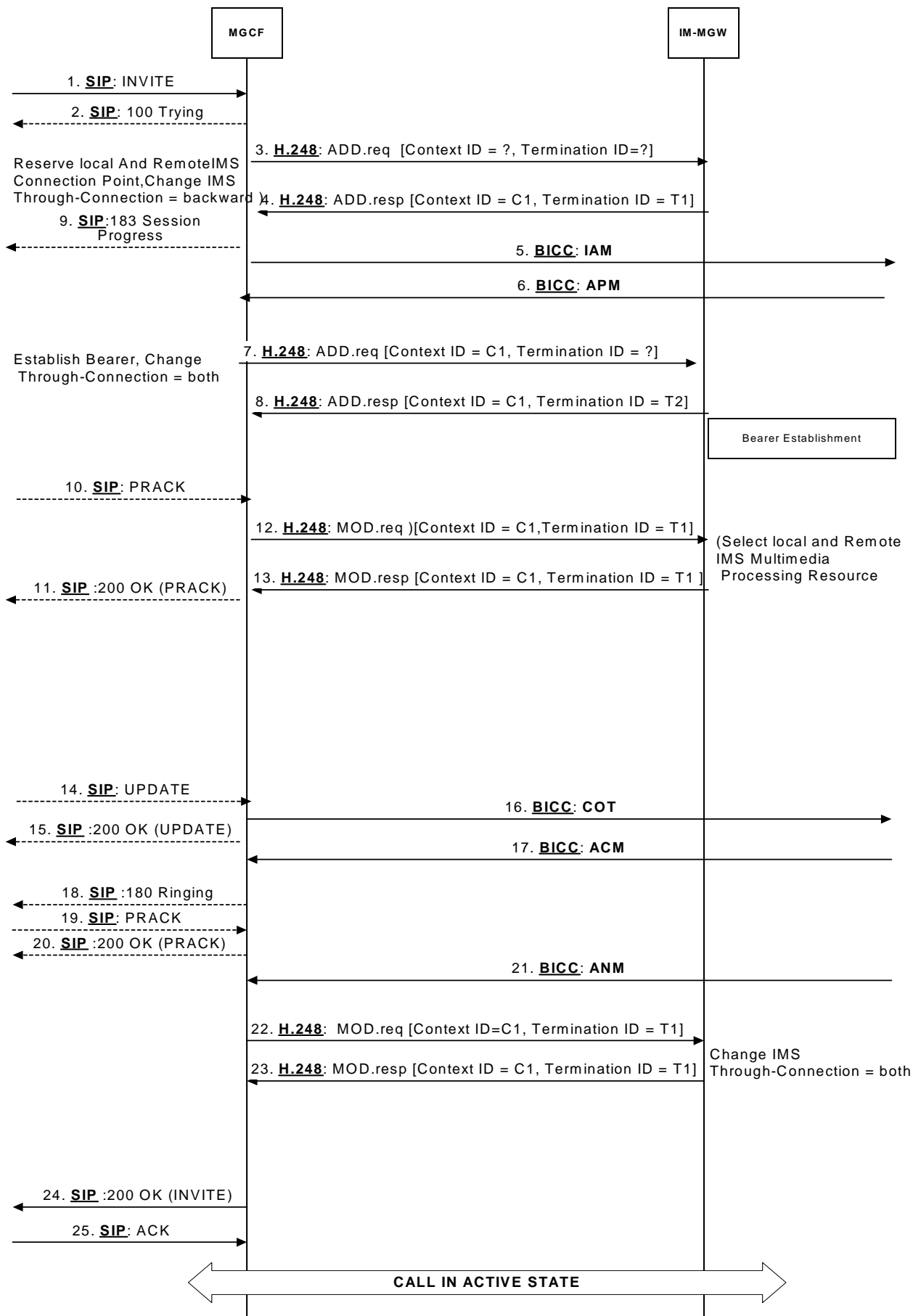

Figure 31: Basic IM CN Subsystem Originating Session, BICC Forward Bearer Establishment (message sequence chart)

9.2.2.2 BICC Backward bearer establishment

9.2.2.2.1 IM-MGW selection

The MGCF shall select an IM-MGW for the bearer connection before it performs the IM CN subsystem session establishment or the CS network side bearer establishment, and before it sends the IAM (signal 8 in Figure 32).

9.2.2.2.2 IM CN subsystem side termination reservation

On receipt of INVITE (signal 1 in figure 32) the MGCF shall initiate the Reserve Local and Remote IMS Connection Points procedure (signal 3 and 4 in figure 32). From the received SDP and local configuration data the MGCF

- shall send the appropriate remote Codec(s), codec port(s) and remote IP connection information to the IM-MGW.
- shall indicate the local codec(s) and requests the port information for these codecs and with the Reserve Value Indicator set to “true” and request (if applicable) and request IP connection information.

Note: The reserve value indicator set to “true” is only applicable if DTMF support together with AMR support are required.

The IM-MGW shall

- reply to the MGCF with the codec– port number combinations, local IP connection information it supports and which of the remote codec(s) it supports.
- reserve the codec(s)

The MGCF shall take the local codecs/port pairs, local IP connection information and send it to the IMS in the Session Progress (signal 5 in Figure 32).

9.2.2.2.3 IM CN subsystem side session establishment

Dependent on what the MGCF receives in PRACK (signal 9 in figure 32) the MGCF may initiate the Select Local and Remote IMS Multimedia Connection Points procedure. If the received SDP is the same as the SDP sent in signal 5 in figure 32 the procedure is not invoked. Otherwise the MGCF shall use the Select Local and Remote IMS Multimedia Processing Resource procedure to provide to the IM-MGW.

- the remote IP configuration information and remote codec and port number to address user data towards the IM CN subsystem as received in the SDP in signal 9 in figure 32.
- optionally send the local codec, codec port information for the codec and the local IP connection data.

Note: This may be triggered if the requirement for DTMF is withdrawn.

The IM-MGW shall update the codec reservation and remote IP configuration data in accordance with the received information.

The MGCF shall include the selected codec(s) and port number(s) and other IP connection data in an SDP answer (signal 10 in Figure 32) sent back to the IMS

9.2.2.2.4 CS network side bearer establishment

The MGCF shall request the IM-MGW to prepare for the CS network side bearer establishment using the Prepare Bearer procedure before sending the IAM to the succeeding node. Within this procedure, the MGCF shall request the IM-MGW to provide a bearer address and a binding reference, and the MGCF shall either provide the IM-MGW with the preferred bearer characteristics or it shall request the IM-MGW to select and provide the bearer characteristics

(signal 6 in Figure 32). After the IM-MGW has replied with the bearer address, the binding reference and the bearer characteristics (if requested), the MGCF sends the IAM to the succeeding node.

9.2.2.2.5 Through-Connection

During the Prepare Bearer procedure, the MGCF shall either use the Change Through-Connection procedure to request the IM-MGW to backward through-connect the BICC termination, or the MGCF shall use this procedure to both-way through-connect the BICC termination already on this stage (signal 6 in Figure 32). During the Reserve IMS connection Point procedure, the MGCF shall use the Change IMS Through-Connection procedure to request the IM-MGW to backward through-connect the IMS termination (signal 3 in Figure 32).

When the MGCF receives the BICC:ANM answer indication, it shall request the IM-MGW to both-way through-connect the terminations using the Change Through-Connection or Change IMS Through-Connection procedures (signal 21 in Figure 32), unless those terminations are already both-way through-connected.

9.2.2.2.6 Codec handling

The IM-MGW may include a speech transcoder based upon the speech coding information provided to each termination.

9.2.2.2.7 Failure handling in MGCF

If any procedure between the MGCF and the IM-MGW is not completed successfully or the MGCF receives a Bearer Released procedure from the IM-MGW, the session shall be cleared as described in Clause 9.2.5, MGCF initiated session clearing or in Clause 9.2.6, IM-MGW initiated session clearing. Alternatively, the MGCF may only release the resources in the IM-MGW that caused the failure, possibly select a new IM-MGW for the connection and continue the session establishment using new resources in the selected IM-MGW.

9.2.2.2.8 Message sequence chart

Figure 32 shows the message sequence chart for the IM CN subsystem originating session when the backward bearer establishment is used. In the chart the MGCF requests seizure of the IM CN subsystem side termination and CS network side bearer termination. When the MGCF receives an answer indication, it requests the IM-MGW to both-way through-connect the terminations.

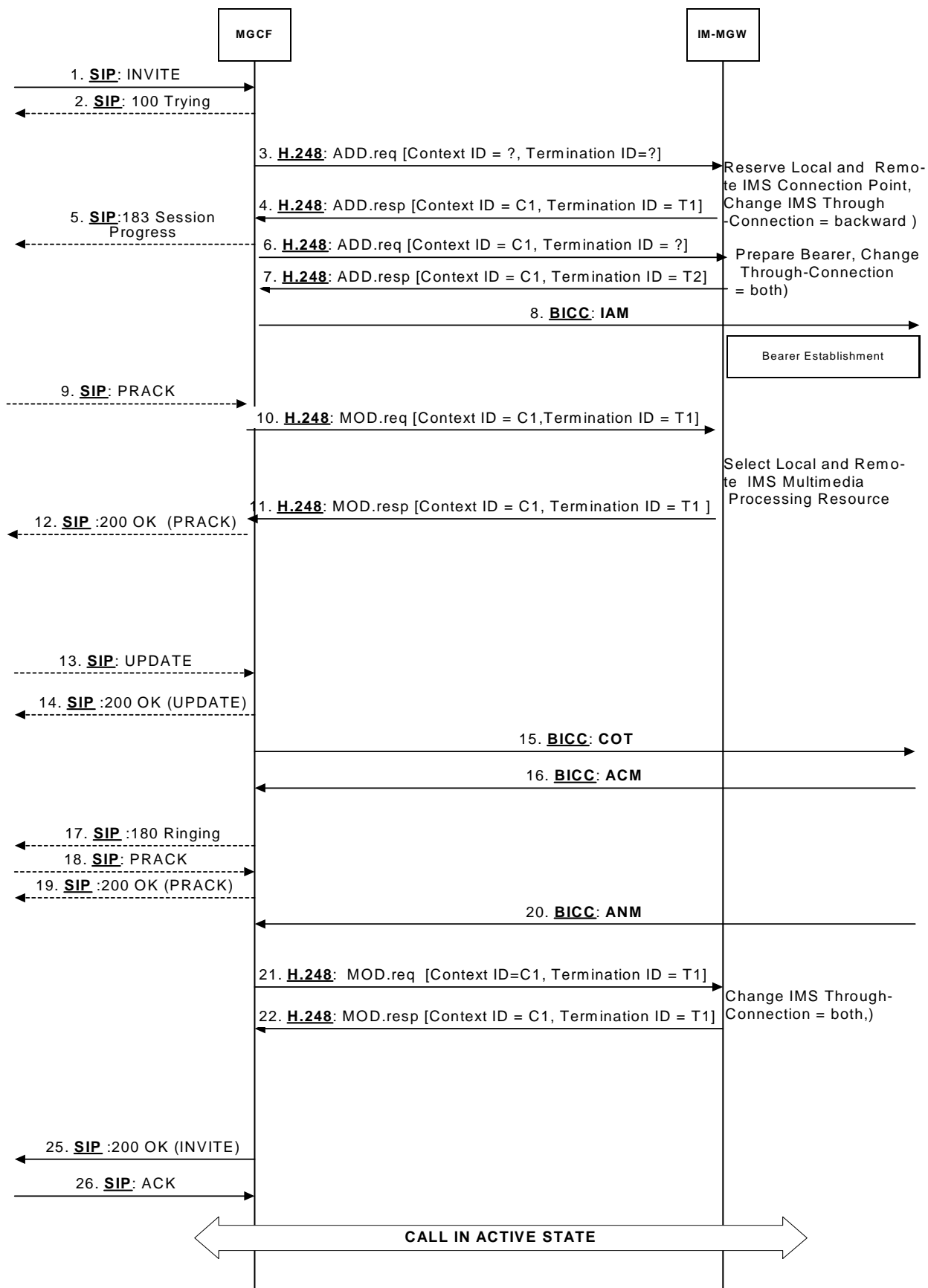

Figure 32: Basic IM CN Subsystem Originating Session, BICC Backward Bearer Establishment (message sequence chart)

9.2.2.3 ISUP

9.2.2.3.1 IM-MGW selection

The MGCF shall select an IM-MGW with circuits to the given destination in the CS domain before it performs the IM CN subsystem session establishment and before it sends the IAM (signal 8 in Figure 33).

9.2.2.3.2 IM CN subsystem side termination reservation

On receipt of INVITE (signal 1 in figure 33) the MGCF shall initiate the Reserve Local and Remote IMS Connection Points procedure (signal 3 and 4 in figure 33). From the received SDP and local configuration data the MGCF

- shall send the appropriate remote Codecs – Codec ports and remote IP connection information to the IM-MGW.
- shall indicate the local Codec(s) and requests the port information for these codec(s), with a reserve value indicator set to “true” (if applicable) and Ip connection information.

Note: The reserve value indicator set to “true” is only applicable if DTMF support together with AMR support are required.

The IM-MGW shall

- reply to the MGCF with the codec– port number combinations, local IP connection information and the remote codec(s) it supports.
- reserve the codec(s)

The MCGF shall take the local codecs/port pairs, local IP connection information and sends it to to the IMS in the Session Progress (signal 5 in Figure 33)

9.2.2.3.3 IM CN subsystem side session establishment

Dependent on what the MGCF receives in PRACK (signal 9 in figure 32) the MGCF may initiate the Select Local and Remote IMS Multimedia Connection Points procedure. If the received SDP is the same as the SDP sent in signal 5 in figure 33 the procedure is not invoked. Others the MGCF shall use the Select Local and Remote IMS Multimedia Processing Resource procedure to provide to the IM-MGW

- the remote IP configuration information and remote codec and port number to address user data towards the IM CN subsystem as received in the SDP in signal 9 in figure 33.
- optionally send the local codec, port information for the codec and the local IP connection data.

Note: This may be triggered if the requirement for DTMF is withdrawn.

The IM-MGW shall update the codec reservation and remote IP configuration data in accordance with the received information.

The MGCF shall include the selected codec(s) and port number(s) and other IP connection data in an SDP answer (signal 10 in Figure 33) sent back to the IMS.

9.2.2.3.4 CS network side circuit reservation.

The MGCF shall request the IM-MGW to reserve a circuit using the Reserve TDM Circuit procedure. The MGCF sends the IAM to the succeeding node including the reserved circuit identity.

9.2.2.3.5 Through-Connection

During the Reserve TDM Circuit and Reserve IMS Connection Point procedures, the MGCF shall either use the Change TDM Through-Connection procedure to request the IM-MGW to backward through-connect the termination, or the MGCF shall use this procedure to both-way through-connect the TDM termination already on this stage (signal 6 in Figure 33). During the Reserve IMS connection Point procedure, the MGCF shall use the Change IMS Through-

Connection procedure to request the IM-MGW to backward through-connect the IMS termination (signal 3 in Figure 33).

When the MGCF receives the ISUP:ANM answer indication, it shall request the IM-MGW to both-way through-connect the terminations using the Change IMS Through-Connection or Change TDM Through-Connection procedures (signal 21 in Figure 33), unless those terminations are already both-way through-connected.

9.2.2.3.6 Continuity Check

The MGCF may request a continuity check on the connection towards the CS network within the IAM message. In this case, the MGCF shall use the Continuity Check procedure towards the IM-MGW to request the generation of a continuity check tone on the TDM termination. The IM-MGW shall then use the Continuity Check Verify procedure to notify the MGCF of an incoming continuity check tone on the corresponding circuit. In addition to other conditions detailed in Section 7, the MGCF shall wait until receiving this notification before sending the COT. (Not depicted in Figure 33)

9.2.2.3.7 Codec handling

The IM-MGW may include a speech transcoder based upon the speech coding information provided to each termination.

9.2.2.3.8 Voice Processing function

A voice processing function located on the IM-MGW may be used to achieve desired acoustic quality on the terminations. If the voice processing function is used, the MGCF shall request the activation of it in the termination towards the CS network using the Activate TDM Voice Processing Function procedure (signal 23 in Figure 33).

9.2.2.3.9 Failure handling in MGCF

If any procedure between the MGCF and the IM-MGW is not completed successfully session shall be released as described in Subclause 9.2.5, Session release initiated by MGCF.

9.2.2.3.10 Message sequence chart

Figure 33 shows the message sequence chart for the IM CN subsystem originating session. In the chart the MGCF requests seizure of the IM CN subsystem side termination and CS network side bearer termination. When the MGCF receives an answer indication, it requests the IM-MGW to both-way through-connect the terminations. The MGCF requests the possible activation of the voice processing functions for the bearer terminations.

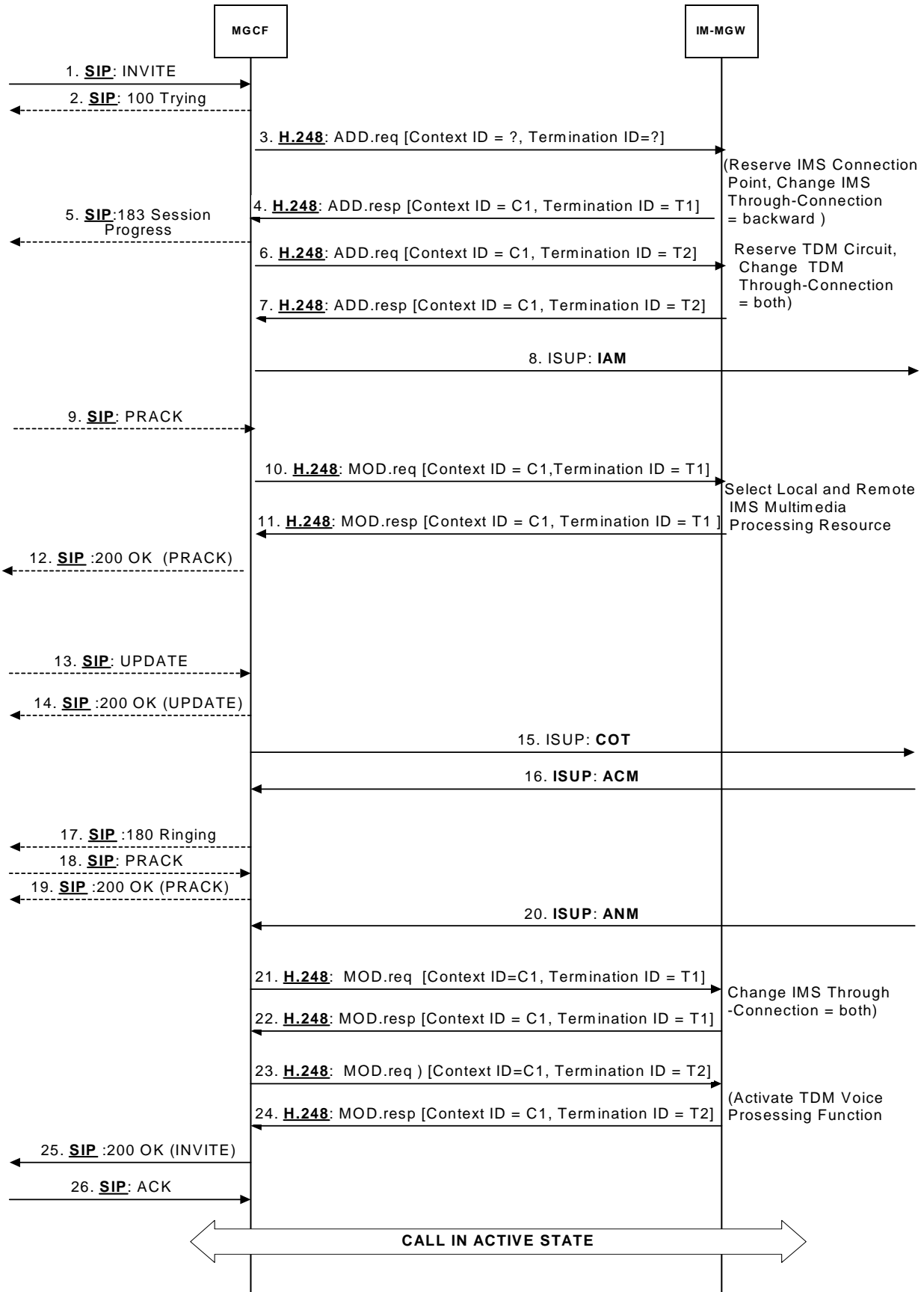

Figure 33: Basic IM CN Subsystem Originating Session, ISUP (message sequence chart)

9.2.3 Basic CS network originated Session

9.2.3.1 BICC Forward bearer establishment

9.2.3.1.1 IM-MGW selection

The MGCF shall select an IM-MGW for the bearer connection before it performs the IM CN subsystem session establishment or the CS network side bearer establishment.

9.2.3.1.2 IM CN subsystem side termination reservation

The MGCF shall use the Reserve Local IMS Connection Point procedure and shall indicate the local Codec(s), requests the port information for these codec(s) with the reserve value indicator set to "true" and request IP connection information from the IM-MGW.

The IM-MGW shall reply to the MGCF with the local codec– port number combinations and local IP connection information.

The MGCF shall send the IP connection information together with the codec(s) and associated port numbers in the INVITE (signal 4 in Figure 34) to the IMS as received from IM-MGW.

9.2.3.1.3 IM CN subsystem side session establishment

The MGCF shall use the Select Local and Remote IMS Multimedia Processing Resource procedure to provide to the IM-MGW the destination IP address and UDP port number for data sent in the user plane towards the IM CN subsystem and speech codec(s). The MGCF shall use the SDP received in signal 6 in figure 34 together with local configuration data and

- shall send the remote codec(s)/port number(s) and remote IP connection data
- may send the local codec /port number and local IP connection data.

Note: The update of the local codec information is only required if the requirement for DTMF support is withdrawn.

The IM-MGW shall reply with which of the remote codec(s) it supports and reserve the codec(s). It may also reconfigure the local codec in accordance with local codec information received.

The MGCF shall send the local reserved codec(s), associated port number(s) and other local IP connection data in the PRACK (signal 9 in Figure 34) to the IMS.

9.2.3.1.4 CS network side bearer establishment

The MGCF shall request the IM-MGW to prepare for the CS network side bearer establishment using the Prepare Bearer procedure. Within this procedure, the MGCF shall request the IM-MGW to provide a bearer address, a binding reference and optionally notify when the bearer is established. The MGCF shall also provide the IM-MGW with the bearer characteristics that was received from the preceding node in the IAM. After the IM-MGW has replied with the bearer address and the binding reference, the MGCF provides the APM message to the preceding node. The MGCF may also provide the IM-MGW-id in the APM message.

9.2.3.1.5 Called party alerting

When the MGCF receives a 180 Ringing message, or when Timer T_{i/w_1} expires, or (T_{i/w_2}) after the initial INVITE is sent and 180 ringing are not received, the MGCF it shall request the IM-MGW to provide an awaiting answer indication (ringing tone) to the calling party using the Send Tone procedure (signal 21 in Figure 34).

9.2.3.1.6 Called party answer

When the MGCF receives a 200 OK message (signal 23 in Figure 31), it shall request the IM-MGW to stop providing the ringing tone to the calling party using the Stop Tone procedure (signal 24 in Figure 34).

9.2.3.1.7 Through-Connection

During the Prepare Bearer procedure, the MGCF shall either use the Change Through-Connection procedure to request the IM-MGW to backward through-connect the BICC termination, or the MGCF shall use this procedure to both-way through-connect the BICC termination already on this stage (signal 11 in Figure 34). During the Reserve IMS connection Point procedure, the MGCF shall use the Change IMS Through-Connection procedure to request the IM-MGW to backward through-connect the IMS termination (signal 2 in Figure 34).

When the MGCF receives the SIP 200 OK(INVITE) (signal 23 in Figure 34), it requests the IM-MGW to both-way through-connect the terminations using the Change IMS Through-Connection or Change Through-Connection procedures (signal 26 in Figure 34), unless those terminations are already both-way through-connected.

9.2.3.1.8 Codec handling

The IM-MGW may include a speech transcoder based upon the speech coding information provided to each termination.

9.2.3.1.9 Failure handling in MGCF

If any procedure between the MGCF and the IM-MGW is not completed successfully or the MGCF receives a Bearer Released procedure from the IM-MGW, the session shall be cleared as described in Clause 9.2.5, MGCF initiated session clearing or in Clause 9.2.6, IM-MGW initiated session clearing. Alternatively, the MGCF may only release the resources in the IM-MGW that caused the failure, possibly select a new IM-MGW for the connection and continue the session establishment using new resources in the selected IM-MGW.

9.2.3.1.10 Message sequence chart

Figure 34 shows the message sequence chart for the CS network originating session when the forward bearer establishment is used. In the chart the MGCF requests seizure of the IM CN subsystem side termination and CS network side bearer termination. When the MGCF receives an answer indication, it requests the IM-MGW to both-way through-connect the terminations

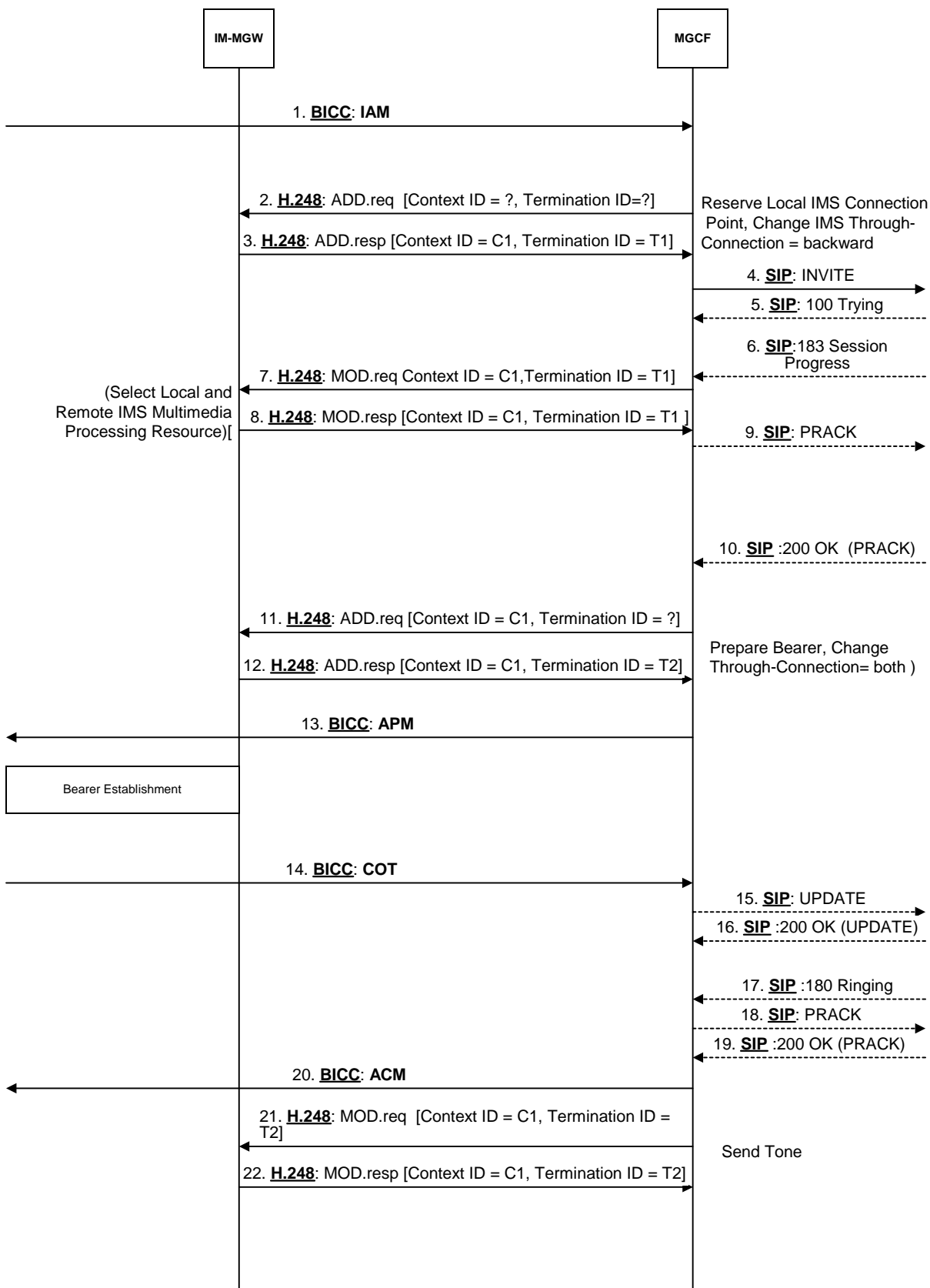

Figure 34/1: Basic CS Network Originating Session, Forward Bearer Establishment (message sequence chart)

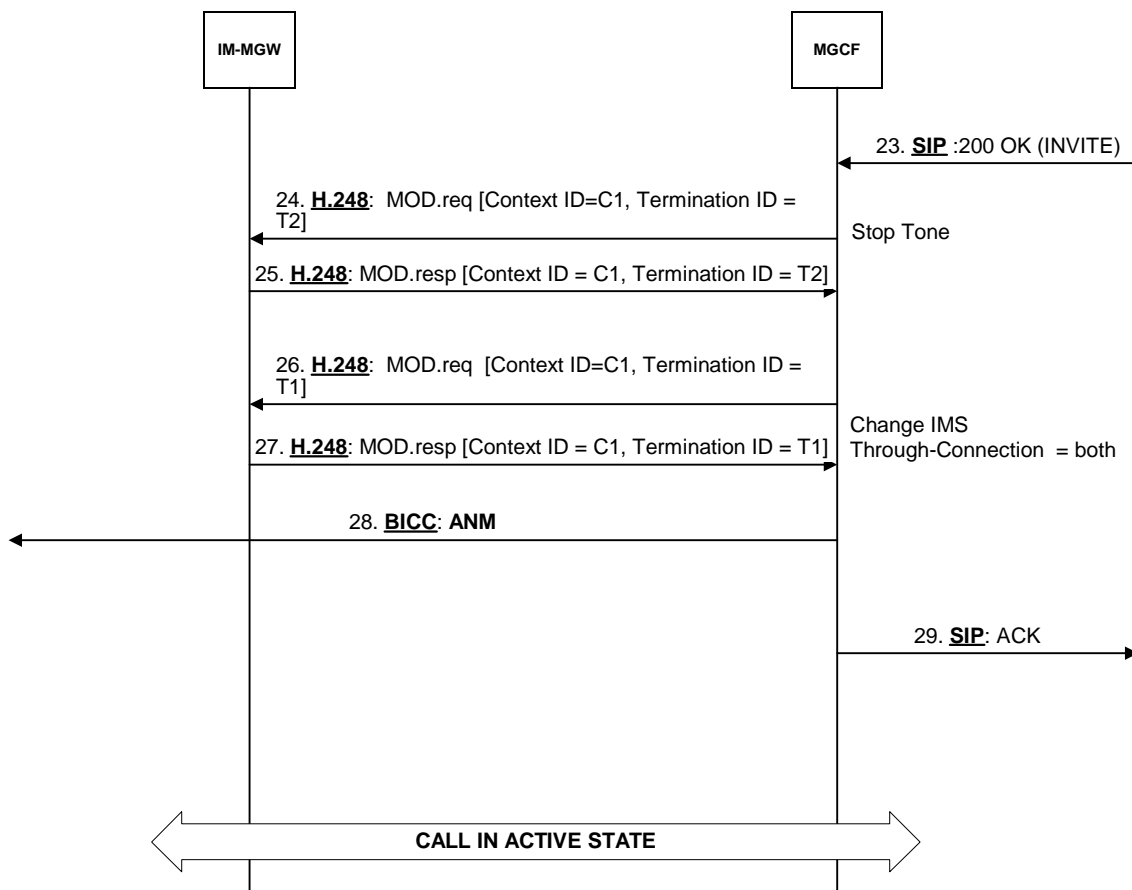

Figure 34/2: Basic CS Network Originating Session, Forward Bearer Establishment (message sequence chart continue)

9.2.3.2 BICC Backward bearer establishment

9.2.3.2.1 IM-MGW selection

The MGCF shall select an IM-MGW for the bearer connection before it performs the IM CN subsystem session establishment or the CS network side bearer establishment (signal 2 in Figure 35).

9.2.3.2.2 CS network side bearer establishment

The MGCF shall request the IM-MGW to establish a bearer using the Establish Bearer procedure. The MGCF provides the IM-MGW with the bearer address, the binding reference and the bearer characteristics that were received from the preceding node in the IAM (signal 1 in Figure 35).

9.2.3.2.3 IM CN subsystem side termination reservation

The MGCF shall use the Reserve Local IMS Connection Point procedure and indicate the local Codec(s) and requests the port information for these codec(s), with the reserve value indicator set to “true” and request IP connection information from the IM-MGW.

The IM-MGW shall reply to the MGCF with the local codec– port number combinations and local IP connection information.

The MGCF shall send the IP connection information together with the local codec(s) and associated port numbers in the INVITE (signal 6 in Figure 35) to the IMS as received from the IM-MGW.

9.2.3.2.4 IM CN subsystem side session establishment

The MGCF shall use the Select Local and Select Remote IMS Multimedia Processing Resource procedure to provide to the IM-MGW the destination IP address and UDP port number for data sent in the user plane towards the IM CN subsystem and codec(s). The MGCF shall use the SDP received in signal 8 in figure 35 together with local configuration data and

- shall send the remote codec(s)/port number(s) and IP connection data
- may send the local codec/port number and IP connection data

Note: The update of the local codec information is only required if the requirement for DTMF support is withdrawn.

The IM-MGW shall reply to the MGCF with which of the remote codec(s) it supports and reserve the codec(s). The local codec configuration is updated in accordance with the received local codec information.

The MGCF shall send the reserved speech codec(s), associated port number(s) and other IP connection data in the PRACK (signal 11 in Figure 35) to the IMS.

9.2.3.2.5 Called party alerting

When the MGCF receives a 180 Ringing message, or when Timer T_{i/w_1} expires, or T_{i/w_2} after the initial INVITE is sent, the MGCF shall request the IM-MGW to provide an awaiting answer indication (ringing tone) to the calling party using the Send Tone procedure (signal 20 in Figure 35).

9.2.3.2.6 Called party answer

When the MGCF receives a 200 OK message (signal 22 in Figure 35), it shall request the IM-MGW to stop providing the ringing tone to the calling party using the Stop Tone procedure (signal 23 in Figure 35).

9.2.3.2.7 Through-Connection

During the Establish Bearer procedure, the MGCF shall either use the Change Through-Connection procedure to request the IM-MGW to backward through-connect the BICC termination, or the MGCF shall use this procedure to both-way through-connect the BICC termination already on this stage (signal 2 in Figure 35). During the Reserve IMS connection Point procedure, the MGCF shall use the Change IMS Through-Connection procedure to request the IM-MGW to backward through-connect the IMS termination (signal 4 in Figure 35).

When the MGCF receives the SIP 200 OK(INVITE) (signal 22 in Figure 35), it shall request the IM-MGW to both-way through-connect the bearer using the Change IMS Through-Connection or Change Through-Connection procedure (signal 25 in Figure 35), unless those terminations are already both-way through-connected.

9.2.3.2.8 Codec handling

The IM-MGW may include a speech transcoder based upon the speech coding information provided to each termination.

9.2.3.2.9 Failure handling in MGCF

If any procedure between the MGCF and the IM-MGW is not completed successfully or the MGCF receives a Bearer Released procedure from the MGW, the session shall be cleared as described in Clause 9.2.5, MGCF initiated session clearing or in Clause 9.2.6, IM-MGW initiated session clearing. Alternatively, the MGCF may only release the resources in the IM-MGW that caused the failure, possibly select a new IM-MGW for the connection and continue the session establishment using new resources in the selected IM-MGW.

9.2.3.2.10 Message sequence chart

Figure 35 shows the message sequence chart for the CS network originating session when the backward bearer establishment is used. In the chart the MGCF requests seizure of the IM CN subsystem side termination and CS

network side bearer termination. When the MGCF receives an answer indication, it requests the IM-MGW to both-way through-connect the terminations.

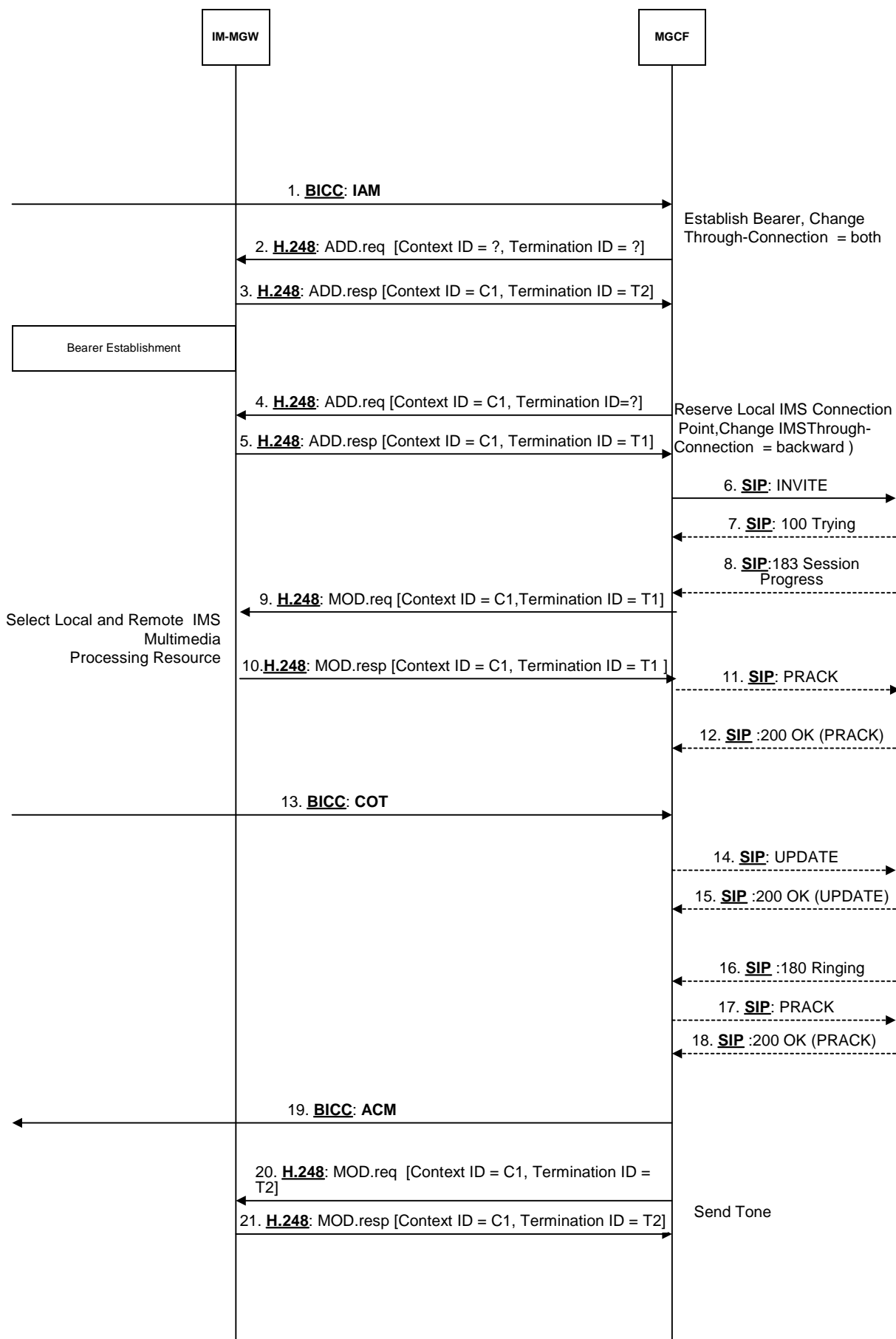

Figure 35/1: Basic CS Network Originating Session, BICC Backward Bearer Establishment (message sequence chart)

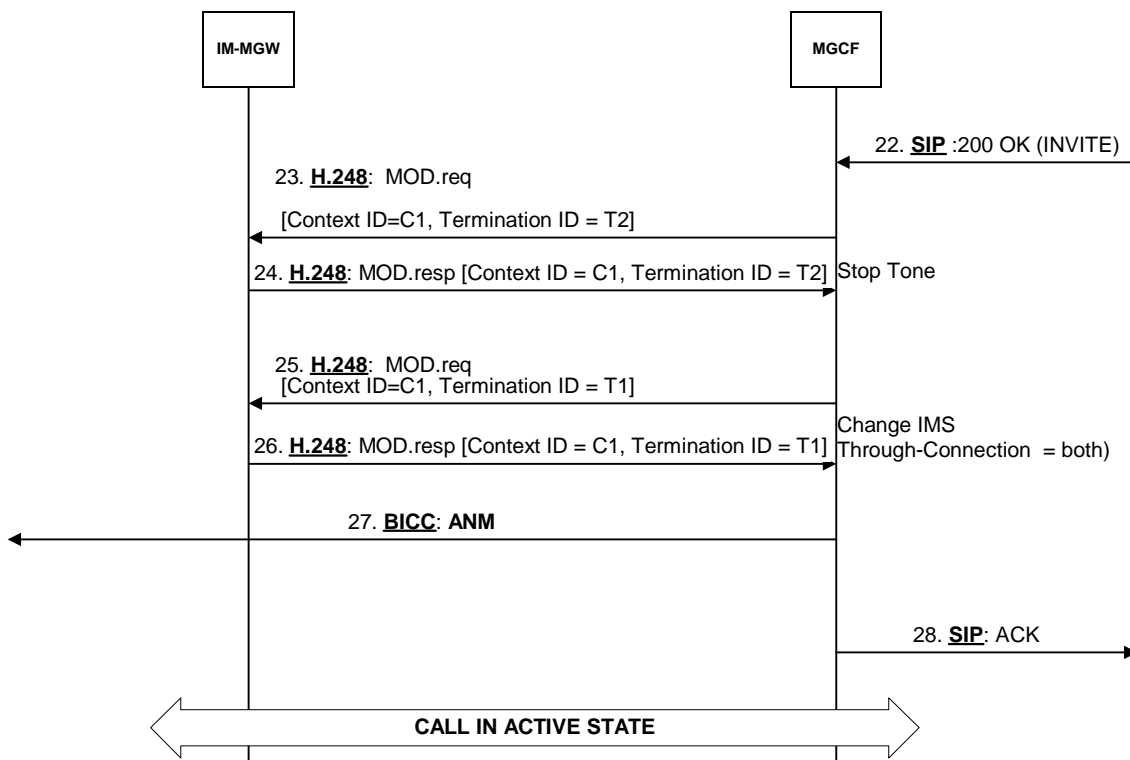

Figure 35/2: Basic CS Network Originating Session, BICC Backward Bearer Establishment (message sequence chart continue)

9.2.3.3 ISUP

9.2.3.3.1 IM-MGW selection

The MGCF selects the IM-MGW based on the received circuit identity in the IAM.

9.2.3.3.2 CS network side circuit reservation

The MGCF shall request the IM-MGW to reserve a circuit using the Reserve TDM Circuit procedure.

9.2.3.3.3 IM CN subsystem side termination reservation

The MGCF shall use the Reserve Local IMS Connection Point procedure and indicate the local Codec(s) and requests the port information for these codec(s), with the reserve value indicator set to “true” and request IP connection information from the IM-MGW.

The IM-MGW shall reply to the MGCF with the local codec– port number combinations and local IP connection information.

The MGCF shall send the IP connection information together with the local codec(s) and associated port numbers in the INVITE (signal 6 in Figure 36) to the IMS as received from the IM-MGW.

9.2.3.3.4 IM CN subsystem side session establishment

The MGCF shall use the Select Local and Select Remote IMS Multimedia Processing Resource procedure to provide to the IM-MGW the destination IP address and UDP port number for data sent in the user plane towards the IM CN

subsystem and codec(s). The MGCF shall use the SDP received in signal 8 in figure 36 together with local configuration data and

- shall send the remote codec(s)/port number(s) and IP connection data
- may send the local codec/port number and IP connection data

Note: The update of the local codec information is only required if the requirement for DTMF support is withdrawn.

The IM-MGW shall reply to the MGCF with which of the remote codec(s) it supports and reserve the codec(s). The local codec configuration is updated in accordance with the received local codec information.

The MGCF shall send the reserved speech codec(s), associated port number(s) and other IP connection data in the PRACK (signal 11 in Figure 36) to the IMS.

9.2.3.3.5 Called party alerting

When the MGCF receives a 180 Ringing message, or when the expiry of Timer T_{i/w_1} expires, or T_{i/w_2} after the initial INVITE is sent, the MGCF shall request the IM-MGW to provide an awaiting answer indication (ringing tone) to the calling party using the Send TDM Tone procedure (signal 20 in Figure 36).

9.2.3.3.6 Called party answer

When the MGCF receives a 200 OK message (signal 22 in Figure 36), it shall request the IM-MGW to stop providing the ringing tone to the calling party using the Stop TDM Tone procedure (signal 23 in Figure 36).

9.2.3.3.7 Through-Connection

Within the Reserve TDM Circuit procedure, the MGCF shall either use the Change TDM Through-Connection procedure to request the IM-MGW to backward through-connect the TDM termination, or the MGCF shall use this procedure to both-way through-connect the TDM termination already on this stage (signal 2 in Figure 36). During the Reserve IMS connection Point procedure, the MGCF shall use the Change IMS Through-Connection procedure to request the IM-MGW to backward through-connect the IMS termination (signal 4 in Figure 36).

When the MGCF receives the SIP 200 OK(INVITE) message, it shall request the IM-MGW to both-way through-connect the terminations using the Change IMS Through-Connection or Change TDM Through-Connection procedure (signal 25 in Figure 36), unless those terminations are already both-way through-connected.

9.2.3.3.8 Continuity Check

If a continuity check on the connection towards the CS network is requested in the IAM message, the MGCF shall use the Continuity Check Response procedure towards the IM-MGW to request loop-back of a received continuity check tone on the TDM circuit. Upon reception of the COT message, the MGCF shall use the Continuity Check Response procedure towards the IM-MGW to request the removal of the loop-back. (Not depicted in Figure 36)

9.2.3.3.9 Codec handling

The IM-MGW may include a speech transcoder based upon the speech coding information provided to each termination.

9.2.3.3.10 Voice Processing function

A voice processing function located on the IM-MGW may be used to achieve desired acoustic quality on the terminations. If the voice processing function is used, the MGCF shall request the activation of it in the termination towards the CS network using the Activate TDM Voice Processing Function procedure (signal 23 in Figure 36).

9.2.3.3.11 Failure handling in MGCF

If any procedure between the MGCF and the IM-MGW is not completed successfully session shall be released as described in Subclause 9.2.5, Session release initiated by MGCF.

9.2.3.3.12 Message sequence chart

Figure 36 shows the message sequence chart for the CS network originating Session. In the chart the MGCF requests seizure of the IM CN subsystem side termination and CS network side bearer termination. When the MGCF receives an answer indication, it requests the IM-MGW to both-way through-connect the terminations. The MGCF may request the possible activation of the voice processing functions for the terminations.

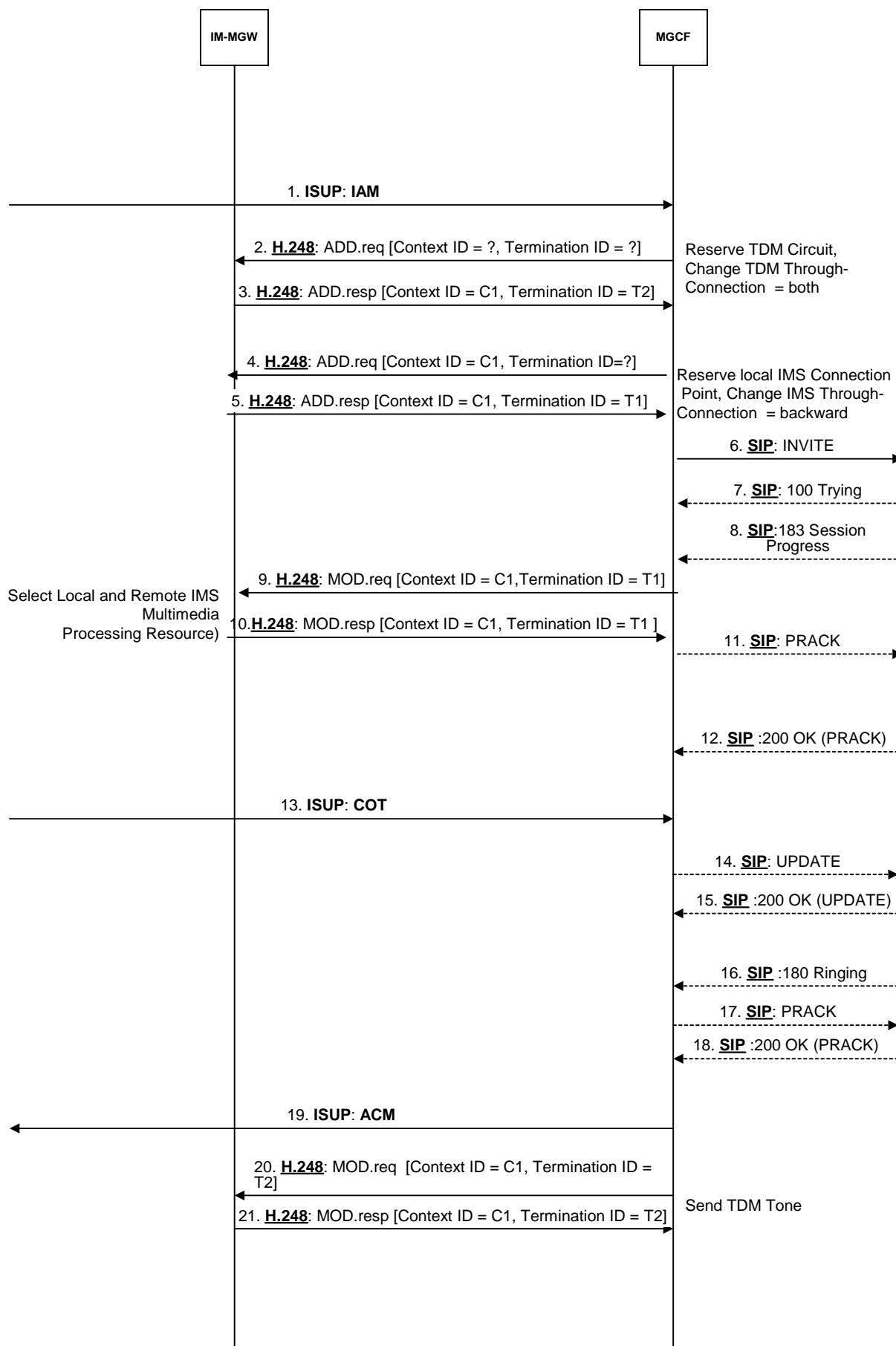

Figure 36/1: Basic CS Network Originating Session, ISUP (message sequence chart)

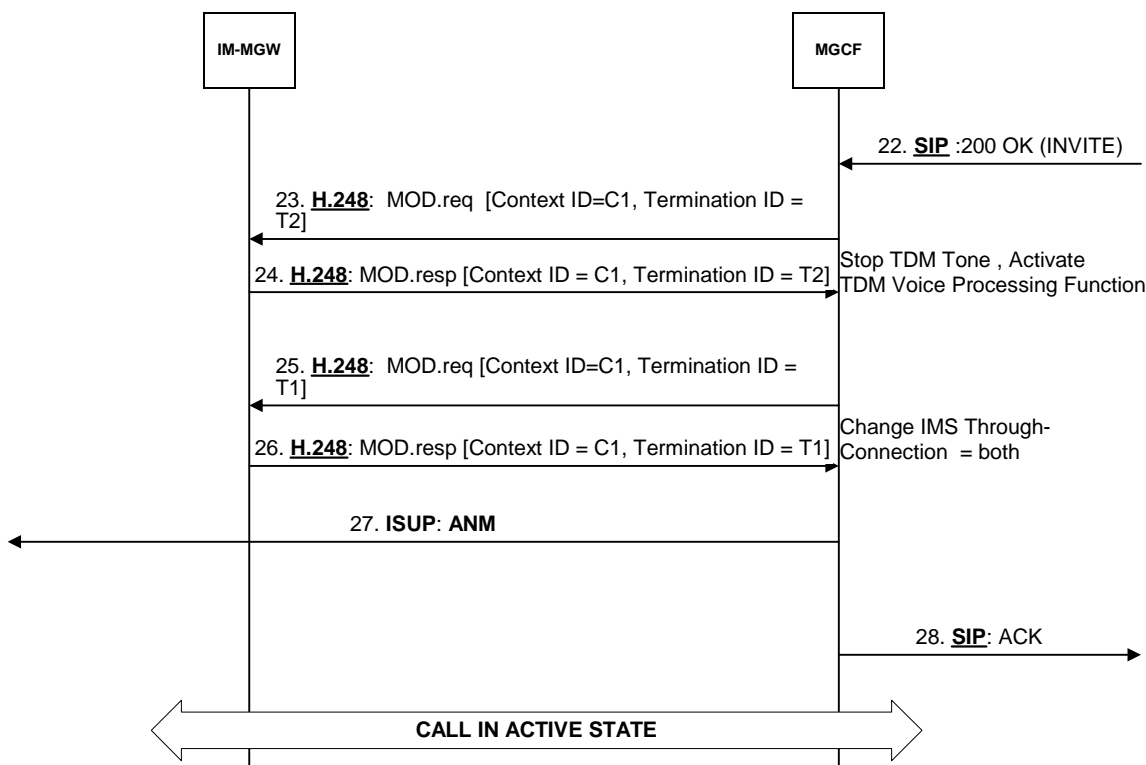

Figure 36/2: Basic CS Network Originating Session, ISUP (message sequence chart continue)

9.2.4 Session release initiated from IM CN subsystem side

9.2.4.1 BICC

9.2.4.1.1 Session release in the IM CN subsystem side

When the MGCF has received a BYE message from the IM CN subsystem side, the MGCF shall release resources in the IM-MGW serving the relevant Mb interface connection by using the “Release IMS Termination” procedure (signals 5 and 6 in Figure 37). After receiving the BYE message, the MGCF shall also send a 200 OK [BYE] message towards the IM CN subsystem (signal 2 in Figure 37).

9.2.4.1.2 Session release in the CS network side

When the MGCF has received a BYE message from the IM CN subsystem side, the MGCF shall send a REL message to the succeeding node (signal 3 in Figure 37). Once the succeeding node has responded with the RLC message (signal 6 in Figure 37), the MGCF shall release the resources for the CS network side in the IM-MGW. If any resources were seized in the IM-MGW, the MGCF shall use the “Release Bearer”, “Change Through-Connection” and “Release Termination” procedures (signals 7 to 10 in Figure 37) to indicate to the IM-MGW that the CS network side bearer termination shall be removed and the bearer shall be released towards the succeeding MGW.

9.2.4.1.3 Message sequence chart

Figure 37 shows the message sequence chart for the session release initiated from the IM CN subsystem side.

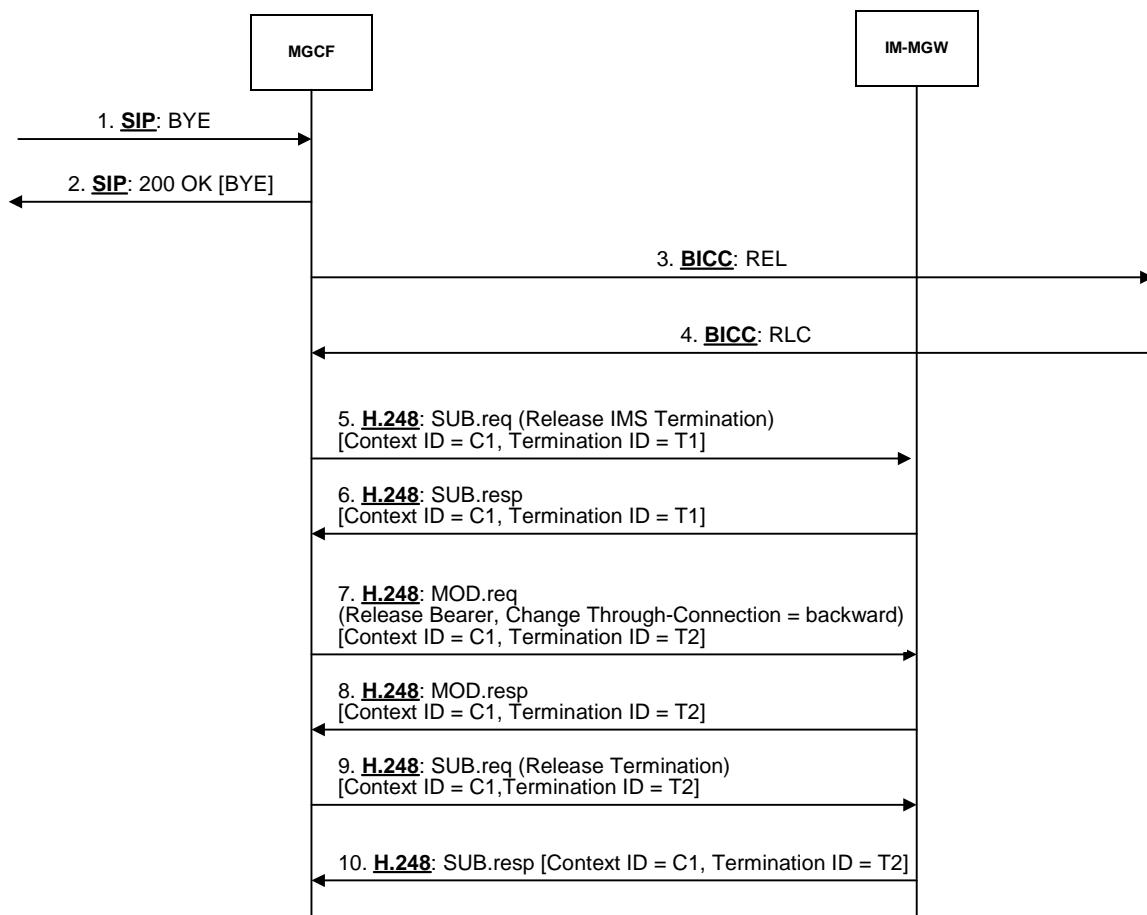

Figure 37: Session release from IM CN subsystem side for BICC (message sequence chart)

9.2.4.2 ISUP

9.2.4.2.1 Session release in the IM CN subsystem side

When the MGCF has received a BYE message from the IM CN subsystem side, the MGCF shall release resources in the IM-MGW serving the relevant Mb interface connection by using the “Release IMS Termination” procedure (signals 3 and 4 in Figure 38). After receiving the BYE message, the MGCF shall also send a 200 OK [BYE] message towards the IM CN subsystem (signal 2 in Figure 38).

9.2.4.2.2 Session release in the CS network side

When the MGCF has received a BYE message from the IM CN subsystem side, the MGCF shall send a REL message to the succeeding node (signal 7 in Figure 38). After sending the REL message, the MGCF shall expect a RLC message (signal 8 in Figure 38) from the succeeding node. The MGCF shall also release the resources for the CS network side in the IM-MGW. If any resources were seized in the IM-MGW, the MGCF shall use the “Release TDM Termination” procedure (signals 5 to 6 in Figure 38) to indicate to the IM-MGW that the CS network side bearer termination can be released.

9.2.4.2.3 Message sequence chart

Figure 38 shows the message sequence chart for the session release initiated from the IM CN subsystem side.

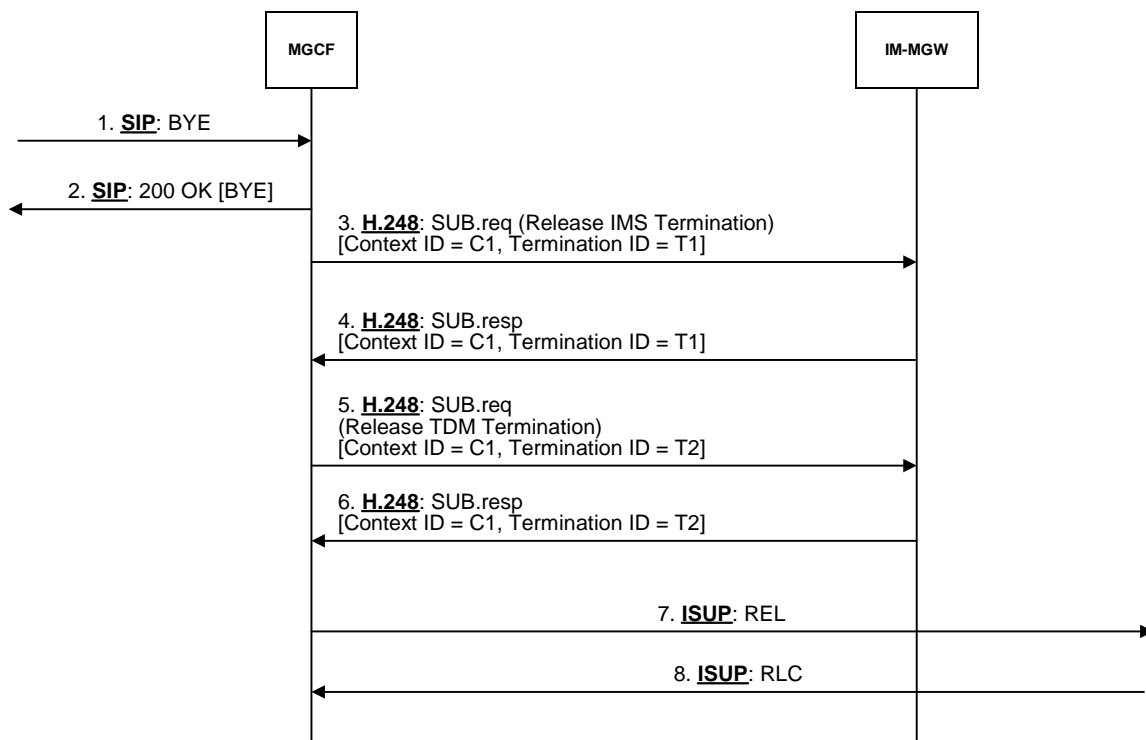

Figure 38: Session release from IM CN subsystem side for ISUP (message sequence chart)

9.2.5 Session release initiated from CS network side

9.2.5.1 BICC

9.2.5.1.1 Session release in the CS network side

When the MGCF receives a REL message from the preceding node (signal 1 in Figure 39), the MGCF shall release resources for the CS network side in the IM-MGW. If any resources were seized in the IM-MGW, the MGCF shall use the “Release Bearer”, “Change Through-Connection” and “Release Termination” procedures to indicate to the IM-MGW that the CS network side bearer termination shall be removed and the bearer shall be released towards the preceding MGW (signal 3 to 6 in Figure 39). After completion of resource release, the MGCF shall send a RLC message towards the preceding node.

9.2.5.1.2 Session release in the IM CN subsystem side

When the MGCF receives a REL message from the preceding node (signal 1 in Figure 39), the MGCF shall send a BYE message to the IM CN subsystem (signal 2 in Figure 39) and the MGCF shall release the resources in the IM-MGW serving the relevant Mb interface connection by using the “Release IMS Termination” procedure (signals 7 and 8 in Figure 39). The MGCF shall also expect to receive a 200 OK [BYE] message from the IM CN subsystem side (signal 10 in Figure 39).

9.2.5.1.3 Message sequence chart

Figure 39 shows the message sequence chart for the session release initiated from the CS network side.

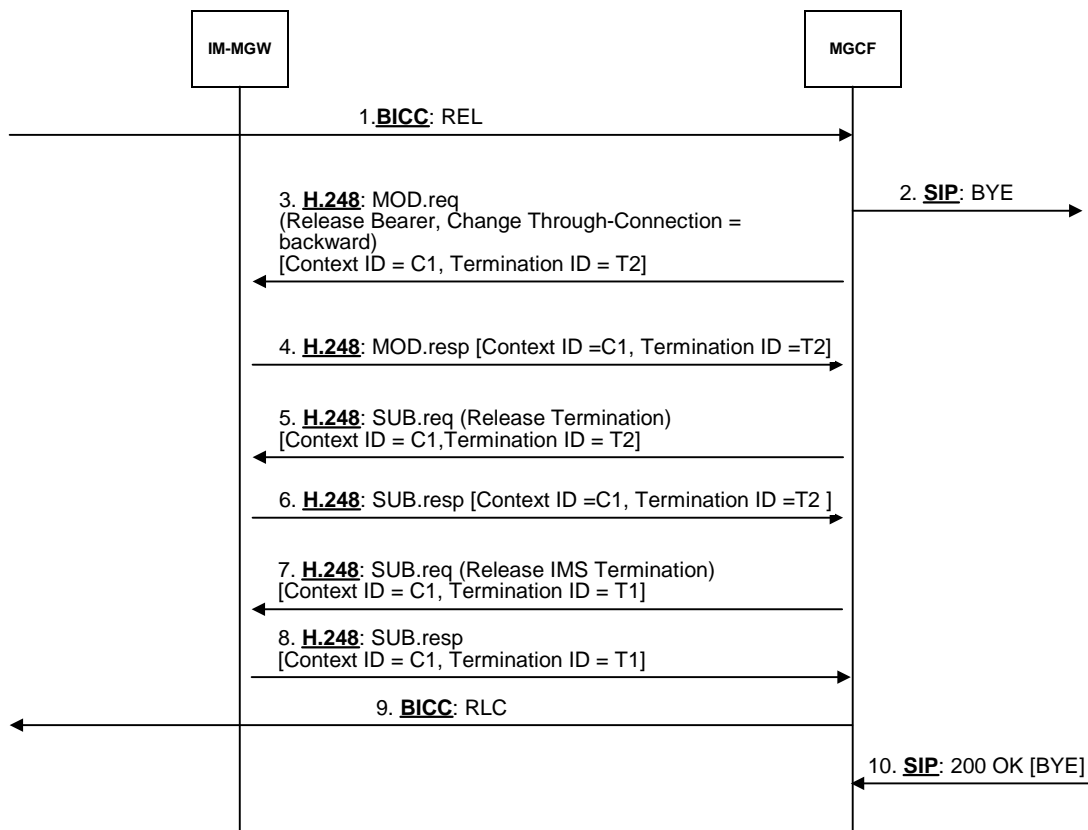

Figure 39: Session release from CS network side for BICC (message sequence chart)

9.2.5.2 ISUP

9.2.5.2.1 Session release in the CS network side

When the MGCF receives a REL message from the preceding node (signal 1 in Figure 40), the MGCF shall release resources for the CS network side in the IM-MGW. If any resources were seized in the IM-MGW, the MGCF shall use the “Release TDM Termination procedures” to indicate to the IM-MGW that the CS network side bearer termination can be released (signal 3 to 4 in Figure 40). After completion of resource release, the MGCF shall send a RLC message towards the preceding node.

9.2.5.2.2 Session release in the IM CN subsystem side

When the MGCF receives a REL message from the preceding node (signal 1 in Figure 40), the MGCF shall send a BYE message to the IM CN subsystem (signal 2 in Figure 40) and the MGCF shall release the resources in the IM-MGW serving the relevant Mb interface connection by using the “Release IMS Termination” procedure (signal 5 to 6 in Figure 40). The MGCF shall also expect to receive a 200 OK [BYE] message from the IM CN subsystem side (signal 8 in Figure 40).

9.2.5.2.3 Message sequence chart

Figure 40 shows the message sequence chart for the session release initiated from the CS network side.

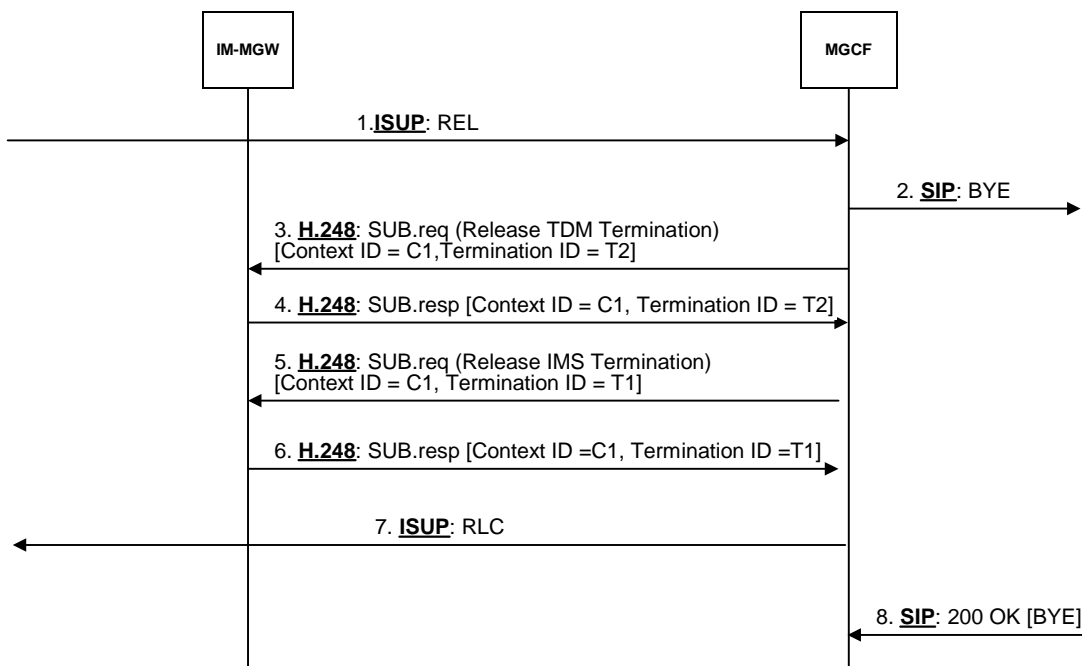

Figure 40: Session release from CS network side for ISUP (message sequence chart)

9.2.6 Session release initiated by MGCF

9.2.6.1 BICC

9.2.6.1.1 Session release in the CS network side

The MGCF shall send a REL message to the succeeding node on the CS network side (signal 1 in Figure 41) Once the succeeding node has responded with the RLC message (signal 3 in Figure 41), the MGCF shall release the resources for the CS network side in the IM-MGW. If any resources were seized in the IM-MGW, the MGCF shall use the “Release Bearer”, “Change Through-Connection” and “Release Termination” procedures to indicate to the IM-MGW that the CS network side bearer termination shall be removed and the bearer shall be released towards the succeeding MGW (signal 4 to 7 in Figure 41).

9.2.6.1.2 Session release in the IM CN subsystem side

The MGCF shall sends a BYE message to the IM CN subsystem side (signal 2 in Figure 41) and the MGCF shall release the resources in the IM-MGW serving the relevant Mb interface connection by using the “Release IMS Termination” procedure (signals 8 and 9 in Figure 41). The MGCF shall also expect to receive a 200 OK [BYE] message is received from the IM CN subsystem side (signal 10 in Figure 41).

9.2.6.1.3 Message sequence chart

Figure 41 shows the message sequence chart for the session release initiated by the MGCF.

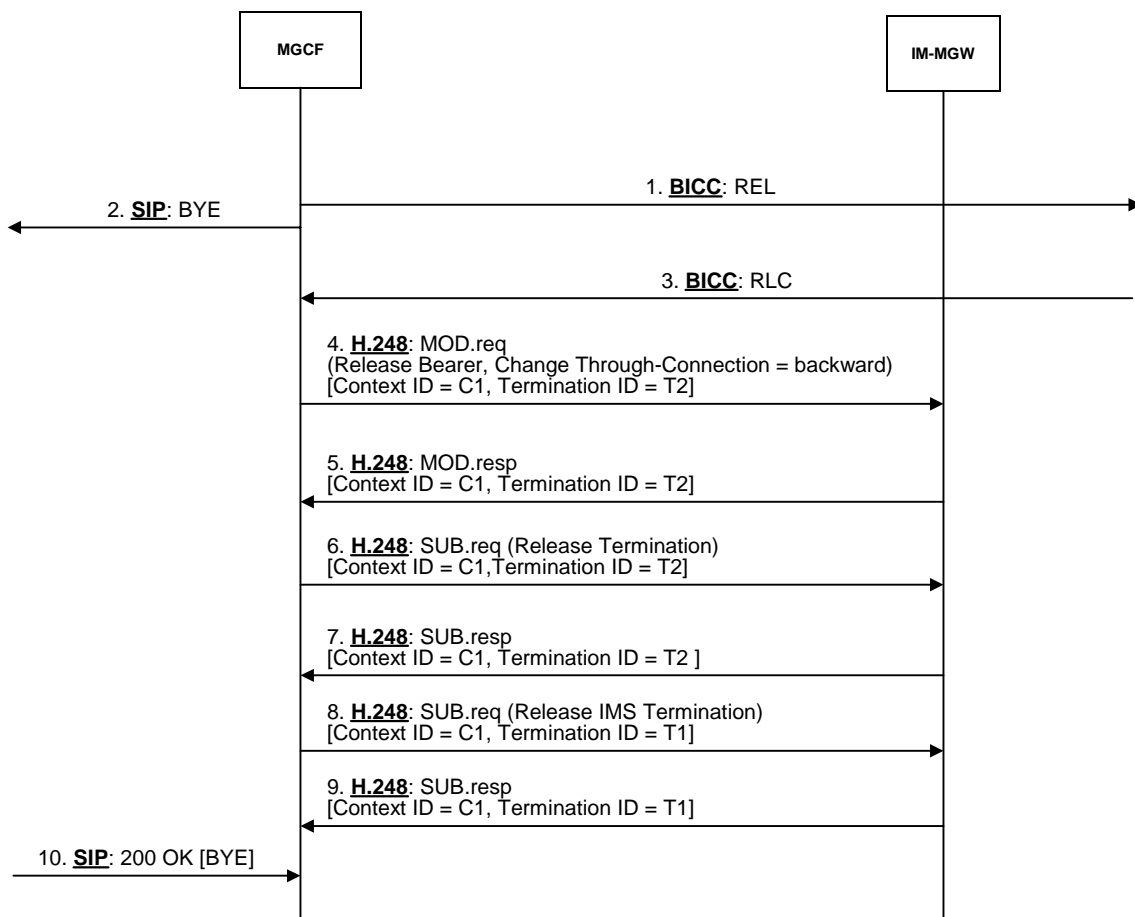

Figure 41: Session release initiated by MGCF for BICC (message sequence chart)

9.2.6.2 ISUP

9.2.6.2.1 Session release in the CS network side

The MGCF shall send a REL message to the succeeding node on the CS network side (signal 6 in Figure 42) and the MGCF shall release the resources for the CS network side in the IM-MGW. If any resources were seized in the IM-MGW, the MGCF shall use the “Release TDM Termination” procedure to indicate to the IM-MGW that the CS network side termination shall be released (signal 4 to 5 in Figure 42). The MGCF shall also expect to receive a RLC message from the succeeding node on the CS network side (signal 8 in Figure 42).

9.2.6.2.2 Session release in the IM CN subsystem side

The MGCF shall send a BYE message to the IM CN subsystem side (signal 1 in Figure 42) and the MGCF shall release the resources in the IM-MGW serving the relevant Mb interface connection by using the “Release IMS Termination” procedure (signal 2 to 3 in Figure 42). The MGCF shall also expect to receive a 200 OK [BYE] message from the IM CN subsystem side (signal 7 in Figure 42).

9.2.6.2.3 Message sequence chart

Figure 42 shows the message sequence chart for the session release initiated by the MGCF.

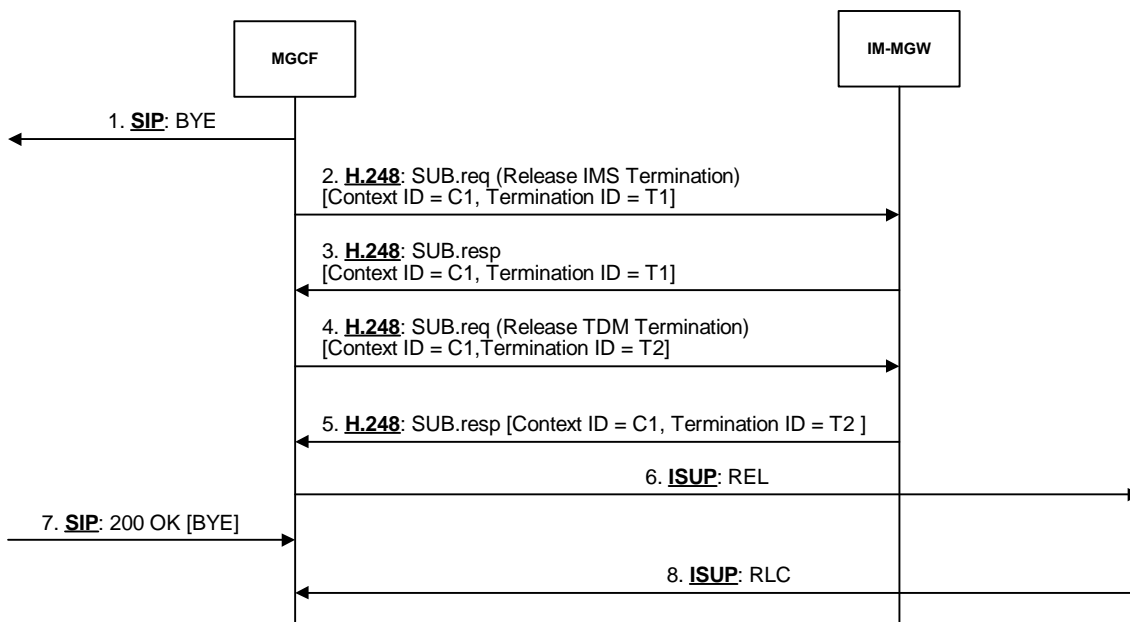

Figure 42: Session release initiated by MGCF for ISUP (message sequence chart)

9.2.7 Session release initiated by IM-MGW

9.2.7.1 BICC

9.2.7.1.1 Session release in the CS network side

Upon receiving from the IM-MGW a “Bearer Release” notification (signal 1 in Figure 43) or a “Termination Out-of-Service” message (not depicted in Figure 43), the MGCF shall send a REL message to the succeeding node on the Cs network side (signal 3 in Figure 43). Once the succeeding node has responded with the RLC message (signal 5 in Figure 43), the MGCF shall release the resources for the CS network side in the IM-MGW, unless the “Termination Out-of-Service” message referred to the “root” termination. If any resources were seized in the IM-MGW, the MGCF shall use the “Release Termination” procedure to indicate to the IM-MGW that the CS network side bearer termination shall be removed (signals 6 and 7 in Figure 43).

9.2.7.1.2 Session release in the IM CN subsystem side

Upon receiving from the IM-MGW a “Bearer Released” notification (signal 1 in Figure 43) or a “Termination Out-of-Service” message (not depicted in Figure 43), the MGCF shall send a BYE message to the IM CN subsystem side (signal 4 in Figure 43) Upon receiving from the IM-MGW a “Bearer Released” notification or a “Termination Out-of-Service” message not referring to the “root” termination, the MGCF shall also release the resources in the IM-MGW serving the relevant Mb interface connection by using the “Release IMS Termination” procedure (signals 8 and 9 in Figure 43). The MGCF shall also expect to receive a 200 OK [BYE] message from the IM CN subsystem side (signal 10 in Figure 43).

9.2.7.1.3 Message sequence chart

Figure 43 shows the message sequence chart for the session release initiated by the IM-MGW.

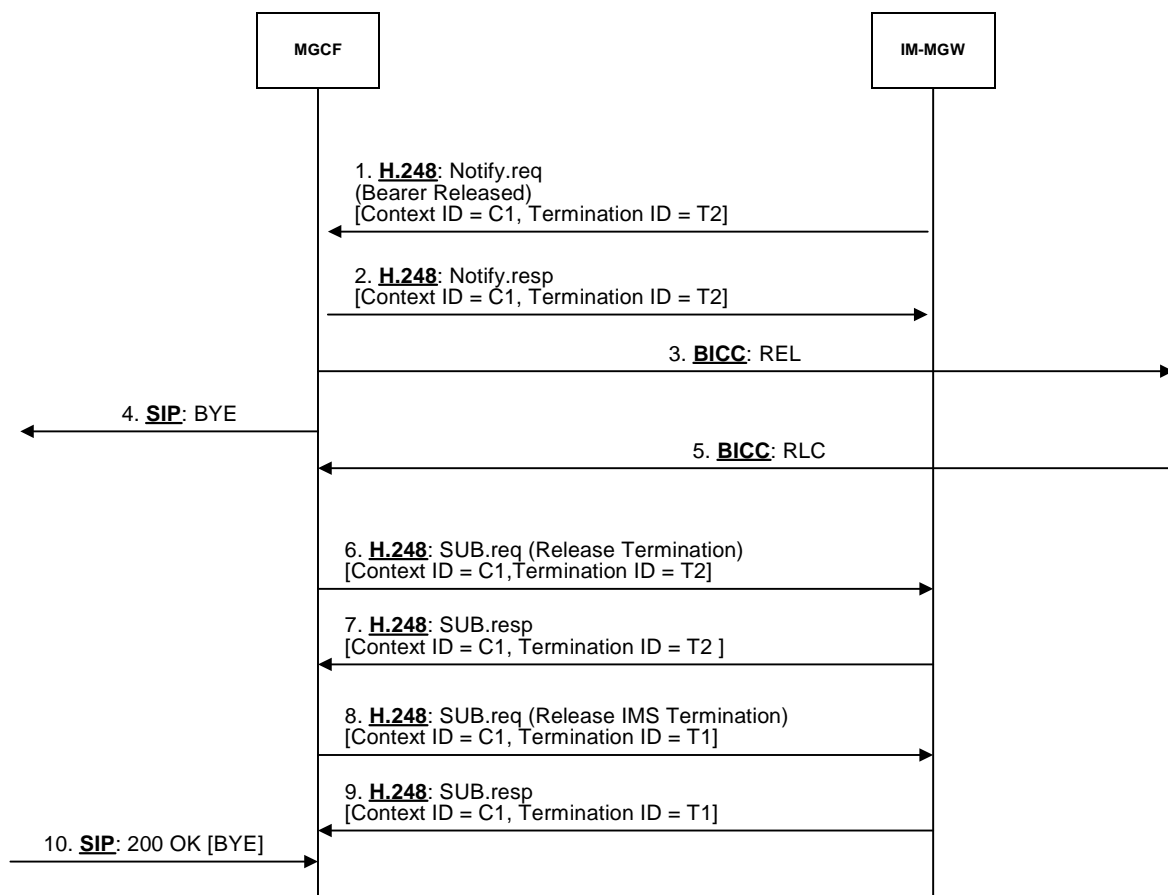

Figure 43: Session release initiated by the IM-MGW for BICC (message sequence chart)

9.2.7.2 ISUP

9.2.7.2.1 Session release in the CS network side

Upon receiving from the IM-MGW a “Termination Out-of-Service” message (signal 1 in Figure 44), the MGCF shall send a REL message to the succeeding node (signal 8 in Figure 44). Upon receiving from the IM-MGW a “Termination Out-of-Service” message not referring to the “root” termination, the MGCF shall also release the resources for the corresponding CS network side termination(s) in the IM-MGW. If any resources were seized in the IM-MGW, the MGCF shall use the “Release TDM Termination” procedure to indicate to the IM-MGW that the CS network side bearer termination can be removed (signals 6 and 7 in Figure 44). The MGCF shall also expect to receive a RLC message on the CS network side (signal 10 in Figure 44).

9.2.7.2.2 Session release in the IM CN subsystem side

Upon receiving from the IM-MGW a “Termination Out-of-Service” message (signal 1 in Figure 44), the MGCF shall send a BYE message to the IM CN subsystem side (signal 3 in Figure 44). Upon receiving from the IM-MGW a “Termination Out-of-Service” message not referring to the “root” termination, the the MGCF shall also release the resources in the IM-MGW for the corresponding terminations towards the IM CN subsystem using the “Release IMS Termination” procedure (signals 4 and 5 in Figure 44). The MGCF shall also expect to receive a 200 OK [BYE] message from the IM CN subsystem side (signal 9 in Figure 44).

9.2.7.2.3 Message sequence chart

Figure 44 shows the message sequence chart for the session release initiated by the IM-MGW.

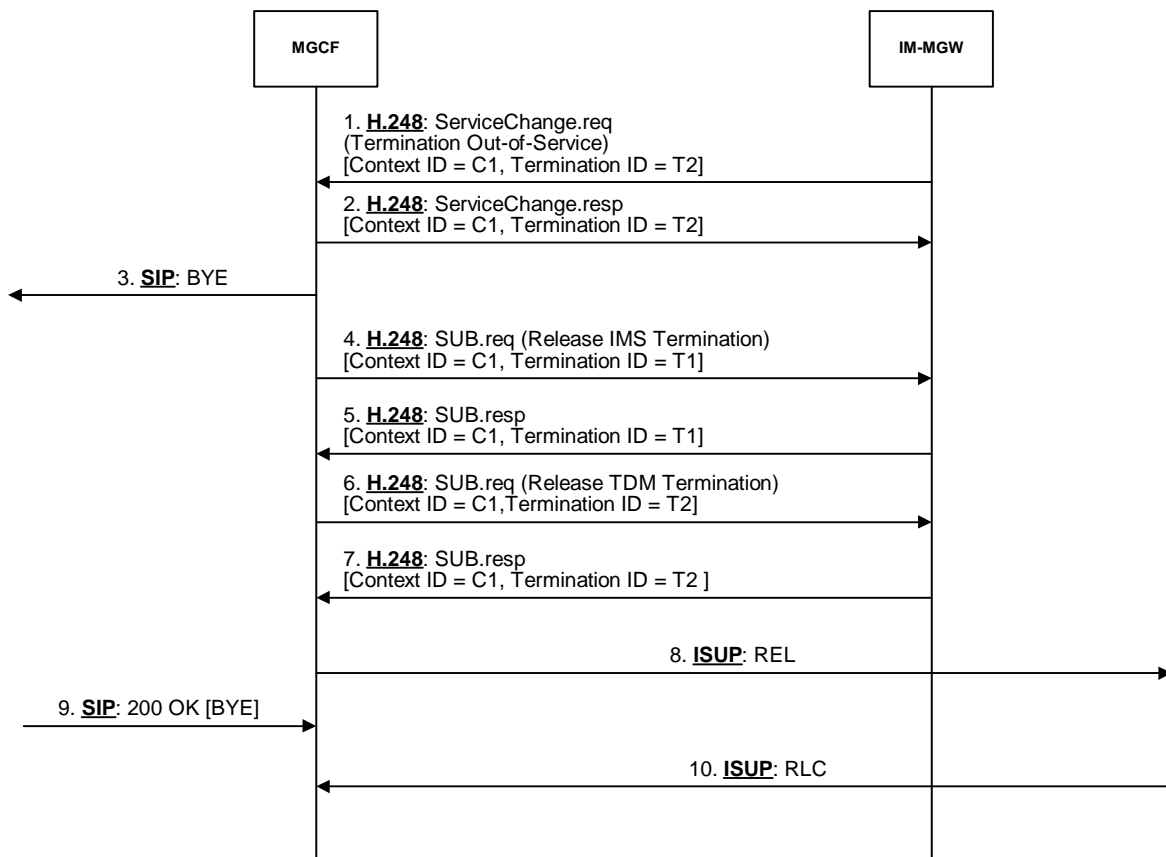

Figure 44: Session release initiated by the IM-MGW for ISUP (message sequence chart)

9.2.8 Handling of RTP telephony events

DTMF digits, telephony tones and signals (telephony events) can be transferred using different mechanisms. For the IM CN Subsystem, 3GPP TS 24.229 [9] defines the usage of the RTP payload format defined for DTMF Digits, Telephony Tones and Telephony Signals in RFC 2833 [34]. When BICC signalling is used in the CS network, telephony signals may be sent either inband or out-of-band as defined in ITU-T Q.1902.4 [30] and in Q.765.5 [35]. The following paragraphs describe the Mn interface procedures to transfer DTMF from RTP format defined in RFC 2833 [34] to the CS CN.

Before the actual usage of the telephony signals can occur the sending/receiving of telephony events need to be agreed with the SDP offer-answer mechanism defined in RFC 3264 [36]. The outcome of the negotiation can be e.g. that no telephony events are sent in RTP payload, telephony events are sent only in one direction or in both directions.

When the offer-answer mechanism based session parameters negotiation results in an agreement that telephony events are sent in the RTP payload and the needed preconditions are fulfilled, telephony events can be sent in RTP payload. This negotiation can be done at call control signalling phase or during an ongoing call.

If the MGCF and IM-MGW support the reception of the RTP transport of MIME type “telephony events” (as defined in RFC 2833 [34]) from the IMS, the following applies:

- For CS Network Originating Sessions, the MGCF shall include the MIME type “telephony events” with default events in the first SDP offer . After the usage of telephony events is agreed in the subsequent offer-answer parameter exchanges and the needed preconditions defined in RFC 3312 [37] are fulfilled, telephony events can be sent as RTP payload.
- In case of IM CN Subsystem Originating Sessions, the MGCF shall accept the MIME type “telephony events” with default events in any SDP answer when it received such an offer.

9.2.8.1 Sending DTMF digits out-of-band to CS CN (BICC)

The MGCF shall use the “Detect IMS RTP Tel Signal” procedure to request the MGW to detect incoming telephone events from the IMS and notify the MGCF about the detected events. The MGW shall use the “Notify IMS RTP Tel Event” procedure for this notification. The termination used to receive DTMF shall be placed in the same context used for the speech of the same call. If the IM-MGW received a “Detect IMS RTP Tel Event” procedure for a termination, the IM-MGW shall not forward inband to the CS network any DTMF received at this termination.

Figure 45 shows the message sequence chart when DTMF digits are received from the IM CN subsystem in the RTP payload. For the first digit, the received RTP message contains all information including the duration and only a single notification is received. For the second digit, the start and the end of the DTMF digit are notified separately.

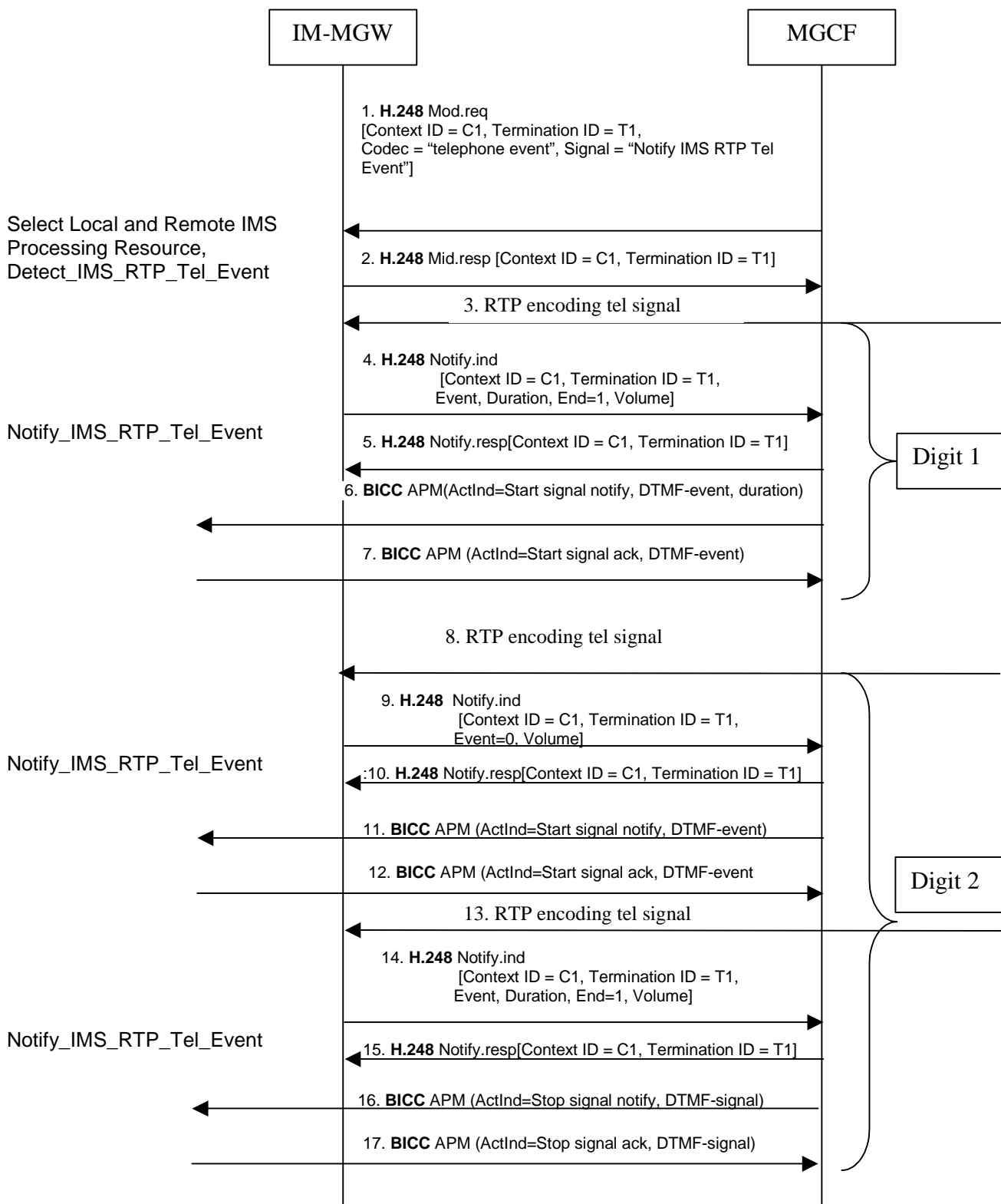

Figure 45: Activation of notification of DTMF digits received in RTP and examples of sending the digits out-of-band to CS CN (message sequence chart)

9.2.8.2 Sending DTMF digits inband to CS CN (ISUP or BICC)

The MGCF shall use the "Reserve IMS Multimedia Processing Resource" procedure with the Codec parameter set to "telephone event" to request the MGW to detect incoming telephone events and transform them into speech signals on the CS side. The MGCF shall use the "Change IMS Through Connection" procedure to request the MGW to backward

through-connect the termination used to receive DTMF from the IMS side. The termination used to receive DTMF shall be placed the same context used for the speech of the same call.

Figure 46 shows the message sequence chart to configure the IM-MGW to receive DTMF detection on the IMS side and transfer the DTMF inband on the CS side.

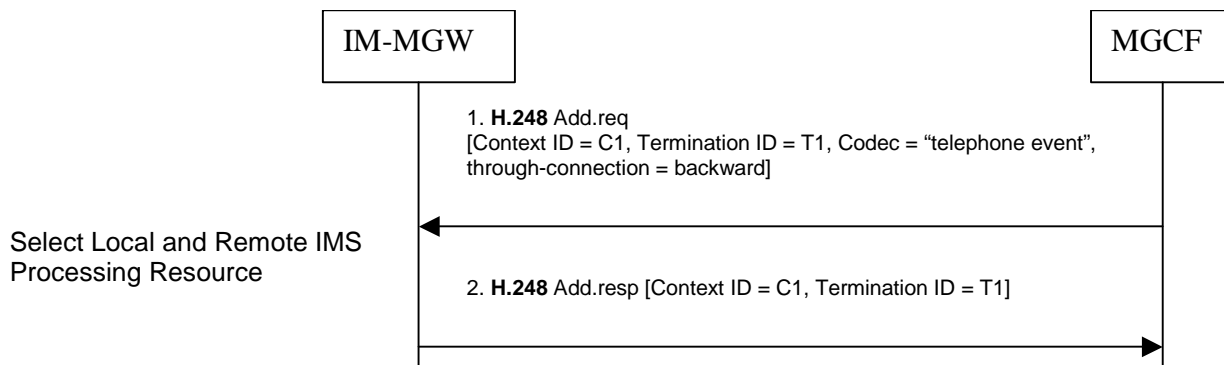

Figure 46: Activation of processing of DTMF digits received in RTP for sending the digits inband to CS CN (message sequence chart)

9.3 Mn Signalling Procedures

This Subclause describes of logical signalling procedures (i.e. message identifiers are not part of the protocol) between the MGCF and IM-MGW. The procedures within this subclause are intended to be implemented using the standard H.248 procedure as defined in [ITU recommendation H.248 [2]] with appropriate parameter combinations..

9.3.1 Procedures related to terminations towards the IM CN Subsystem

A mapping of the procedures defined here to H.248 procedures and parameters is provided in 3GPP TS 29.332 [15].

9.3.1.1 Reserve IMS Connection Point

This procedure is used to reserve an IP address and a UDP Port for an Mb interface connection. The MGCF uses the Reserve IMS Connection Point message to request the assignment of a new termination of an IP bearer at the MGW. The MGW replies with the Reserve IMS Connection Point Ack message, providing the ID of the new termination and the assigned IP address and UDP port.

9.3.1.2 Reserve IMS Multimedia Processing Resource

This procedure is used to reserve multimedia-processing resources for a Mb interface connection. The MGCF sends the Reserve IMS Multimedia Processing Resource Message to the IM-MGW. Within this message, the MGCF shall either request a new termination within an existing context or a new context or refer to an existing termination. Furthermore, the MGCF shall provide all necessary information on the codec to be used as well as the IP Address and UDP Port where the MGW shall send IP packages. The MGW shall reply with the Reserve IMS Multimedia Processing Resource Ack Message, providing the new termination ID and context ID.

9.3.1.3 Change IMS Through-Connection

This procedure is used by the MGCF to modify the through-connection (forward, backward, both-way, inactive) of a termination at the IM-MGW towards the IMS. This procedure is the same as Change Through Connection in TS 23.205 [27].

9.3.1.4 Release IMS Termination

This procedure is used by the MGCF to release a termination towards the IMS and free all related resources.

Table 19: Release IMS termination

Procedure	Initiated	Information element name	Information element required	Information element description
Release IMS Termination	MGCF	Context	M	This information element indicates the context for the bearer termination.
		Bearer Termination	M	This information element indicates the bearer termination to be released.
Release IMS Termination Ack	IM-MGW	Context	M	This information element indicates the context where the command was executed.
		Bearer Termination	M	This information element indicates the bearer termination where the command was executed.

9.3.1.5 Detect IMS RTP Tel Event

This procedure is used by the MGCF to request from the MGW the detection of telephony events signalled within RTP according to RFC 2833 [34] and the notification of received telephony events.

Table 20: Procedures toward the IM Subsystem: Detetct IMS RTP Tel Event

Procedure	Initiated	Information element name	Information element required	Information element description
Detetct IMS RTP Tel Event	MGCF	Context	M	This information element indicates the existing context.
		IMS Termination	M	This information element indicates the existing bearer termination.
		Notify IMS RTP Tel Event	M	This information element indicates that the MGCF request notifications of type "IMS RTP Tel Event" about received telephony events
		Events	O	This information element indicates the list of events, as defined in in RFC 2833, for which a notification is requested. If this information element is omitted, a notification for the default events of RFC 2833 is requested.
Detetct IMS RTP Tel Event Ack	IM-MGW	Context	M	This information element indicates the context where the command was executed.
		IMS Termination	M	This information element indicates the IMS termination where the command was executed.

9.3.1.6 Notify IMS RTP Tel Event

This procedure is used by the MGW to notify the MGCF about the detection of telephony events signalled within RTP according to RFC 2833 [34].

Table 21: Procedures toward the IM Subsystem: Detect IMS RTP Tel Event

Procedure	Initiated	Information element name	Information element required	Information element description
Notify IMS RTP Tel Event	IM-MGW	Context	M	This information element indicates the existing context.
		IMS Termination	M	This information element indicates the existing bearer termination.
		Notify IMS RTP Tel Event	M	This information element indicates that the IM-MGW notifies about received telephony events.
		Event	M	As "event" in RFC 2833
		Duration	M	As "duration" defined by RFC 2833.
		End	M	As "E" defined by RFC 2833.
		Volume	M	As "volume" defined by RFC 2833.
Notify IMS RTP Tel Event Ack	MGCF	Context	M	This information element indicates the context where the command was executed.
		Beginning	M	This information element indicates that a new event is described and is derived from the RTP marker bit as described in RFC 2833.

9.3.1.7 Termination Out-of-Service

This procedure is used by the IM-MGW to indicate towards the MGCF that one or several physical termination(s) will go out of service. This procedure is the same as Termination Out-of-Service in TS 23.205 [27].

9.3.2 Procedures related to a termination towards an ISUP network

A mapping of the procedures defined here to H.248 procedures and parameters is provided in 3GPP TS 29.332 [15].

9.3.2.1 Reserve TDM Circuit

This procedure is used by the MGCF to reserve a TDM circuit in the IM-MGW towards the preceding/succeeding CS network element.

Table 22: Reserve TDM Circuit procedure

Procedure	Initiated	Information element name	Information element required	Information element description
Reserve TDM Circuit	MGCF	Context/Context Request	M	This information element indicates the existing context or requests a new context for the bearer termination.
		Bearer Termination	M	This information element indicates the physical bearer termination for the TDM circuit.
		Bearer Service Characteristics	M	This information element indicates the bearer service requested by the user.
Reserve Circuit Ack	IM-MGW	Context	M	This information element indicates the context where the command was executed.
		Bearer Termination	M	This information element indicates the bearer termination where the command was executed.

9.3.2.2 Change TDM Through-Connection

This procedure is used by the MGCF to modify the through-connection (forward, backward, both-way, inactive) of a TDM termination at the IM-MGW towards the PSTN.

This procedure is the same as Change Through Connection in TS 23.205 [27].

9.3.2.3 Activate TDM Voice-Processing Function

This procedure is used by the MGCF to activate or de-activate a voice processing function of a TDM termination at the IM-MGW towards the PSTN. This voice processing function may include a cancellation for electronic echoes.

This procedure is the same as Activate Voice Processing Function in TS 23.205 [27].

9.3.2.4 Send TDM Tone

This procedure is used by the MGCF to order the IM-MGW to generate a ringing tone at a TDM termination towards the PSTN.

This procedure is the same as Send Tone in TS 23.205 [27].

9.3.2.5 Stop TDM Tone

This procedure is used by the MGCF to order the IM-MGW to stop generating a ringing tone at a TDM termination towards the PSTN.

This procedure is the same as Stop tone in TS 23.205 [27].

9.3.2.6 Play TDM Announcement

This procedure is used by the MGCF to order the IM-MGW to generate an announcement at a TDM termination towards the PSTN. The MGCF may request a notification that the announcement is completed. This procedure is the same as Play Announcement in TS 23.205 [27]. This procedure is optional.

9.3.2.7 TDM Announcement Completed

This procedure is used by the IM-MGW to notify the MGCF that an announcement at a TDM termination towards the PSTN is completed. This procedure is the same as Announcement Completed in TS 23.205 [27]. This procedure is optional.

9.3.2.8 Stop TDM Announcement

This procedure is the same as Stop Announcement TS 23.205 [27]. This procedure is used by the MGCF to order the IM-MGW to stop generating an announcement at a TDM termination towards the PSTN. This procedure is optional.

9.3.2.9 Continuity Check

This procedure is used by the MGCF to order the IM-MGW to generate a continuity check tone at a TDM termination towards the PSTN and to inform the MGCF about the result of the continuity check as soon as the continuity check tone is received or a time-out occurs. This procedure is optional.

Table 23: Continuity Check procedure

Procedure	Initiated	Information element name	Information element required	Information element description
Continuity check	MGCF	Context/Context Request	M	This information element indicates the existing context or requests a new context for the bearer termination.
		TDM Termination	M	This information element indicates the existing bearer termination
		Request for continuity tone sending	M	This information request the IM-MGW to apply the continuity check procedure on the indicated TDM termination
		Request for continuity check tone detection	M	This information request the IM-MGW to inform e continuity check procedure on the indicated TDM termination
Continuity Check Ack	IM-MGW	Context	M	This information element indicates the context where the command was executed.

9.3.2.10 Continuity Check Verify

This procedure is used by the IM-MGW to indicate towards the MGCF that the continuity check at a TDM termination towards the PSTN has been completed and to return the result of the check: success or failure. This procedure is optional.

Table 24: Continuity Check Verify procedure

Procedure	Initiated	Information element name	Information element required	Information element description
Continuity check Verify	IM-MGW	Context/t	M	This information element indicates the context where the command was executed.
		TDM Termination	M	This information element indicates the TDM termination involved in the procedure
		Outcome of the continuity check	M	This information element indicates the outcome of the continuity check (successful/unsuccessful)
Continuity Check Verify Ack	MGCF	Context	M	This information element indicates the context where the command was executed.

9.3.2.11 Continuity Check Response

This procedure is used by the MGCF to order the IM-MGW to loop back an incoming continuity check tone at a TDM termination towards the PSTN. This procedure is optional.

Table 25: Continuity Check Response procedure

Procedure	Initiated	Information element name	Information element required	Information element description
Continuity check response	MGCF	Context/Context Request	M	This information element indicates the existing context or requests a new context for the bearer termination.
		TDM Termination	M	This information element indicates the existing bearer termination
		Request for loop back of the continuity tone	M	This information request the IM-MGW to loop back the the continuity check tone on the indicated TDM termination
Continuity Check Response Ack	IM-MGW	Context	M	This information element indicates the context where the command was executed.

9.3.2.12 Release TDM Termination

This procedure is used by the MGCF to release a TDM termination at the IM-MGW towards the PSTN and free all related resources.

Table 26: Release TDM Termination procedure

Procedure	Initiated	Information element name	Information element required	Information element description
Release TDM Termination	MGCF	Context	M	This information element indicates the context for the bearer termination.
		Bearer Termination	M	This information element indicates the bearer termination to be released.
Release TDM Termination Ack	IM-MGW	Context	M	This information element indicates the context where the command was executed.
		Bearer Termination	M	This information element indicates the bearer termination where the command was executed.

9.3.2.13 Termination Out-of-Service

This procedure is used by the IM-MGW to indicate towards the MGCF that one or several physical termination(s) will go out of service. This procedure is the same as Termination Out-of-Service in TS 23.205 [27].

9.3.3 Procedures related to a termination towards a BICC network

The procedures detailed in ITU.T Q.1950 [31] and 3GPP TS 29.232 [33] shall be applied. As those procedures are already defined in those specifications, they are not re-described here.

The call related procedures listed in Table 27 shall be supported. For terminations connecting the MGCF with a 3GPP CS domain on a direct link, the procedures may be applied as described in 3GPP TS 29.232 [33]. For other terminations, the corresponding Q.1950 procedures shall be applied without the additions and modifications defined in TS 29.232.

NOTE: In Subclause 9.3.2, the terminology of TS 29.232 [33] is applied. This does not preclude the use of the corresponding ITU-T Q.1950 [31] procedures

Table 27: Correspondence between applied Q.1950 call-related procedures and 3GPP TS 29.232 procedures

Procedures defined in Q.1950	Procedure defined in 3GPP TS 29.232	Remarks
Establish_BNC_Notify+(tunnel)	Establish Bearer	
Prepare_BNC_Notify+(tunnel)	Prepare Bearer	
Cut_Through	Change Through-Connection	
Cut_BNC (MOD H.248 Command).	Release Bearer	
Cut_BNC (SUB H.248 Command).	Release Termination	
BNC Established	Bearer Established	
BNC Release	Bearer Released	
Insert_Tone	Send Tone	
Insert Tone	Stop Tone	
Insert_Announcement	Play Announcement	Optional
Insert Announcement	Stop Announcement	Optional
Signal Completion	Announcement Completed	Optional
Confirm_Char	Confirm Char	Optional
Modify Char	Modify Bearer Characteristics	Optional
Reserve_Char_Notify	Reserve Char	Optional
BNC Modified	Bearer Modified	Optional
Echo Cancellor	Activate Voice Processing Function	Optional
Tunnel (MGC-MGW)	Tunnel Information Down	Conditional: For IP Transport at BICC termination
Tunnel (MGW-MGC)	Tunnel Information Up	Conditional: For IP Transport at BICC termination
BIWF Service Cancellation Indication	Termination Out-of-Service	

9.3.4 Non-call related Procedures

The procedures from 3GPP TS 23.205 [27] detailed in table 28 shall be applied for the IM-MGW handling component of the Mn interface.

Table 28: Non-call related procedures

Procedure defined in 3GPP TS 29.232	Remarks
MGW Out-of-Service	
MGW Communication UP	
MGW Restoration	
MGW RegLister	
MGW Re-register	
(G)MSC Server Ordered Re-register	
(G)MSC Server Restoration	
(G)MSC Server Out of Service	
Termination Out-of-Service	
Termination Restoration	
Audit Value	
Audit Capability	
Capability Update	
Command Reject	

Annex A (informative): Change history

Change history							
Date	TSG #	TSG Doc.	CR	Rev	Subject/Comment	Old	New
2001-02					Version 0.0.0 Presented to CN3 #16 - Sophia Antipolis - Initial Proposal		0.0.0
2001-05					Tdocs N3-010185, N3-010199, N3-010201 and N3-010210 agreed at CN3#17 - Rio Grande, Puerto Rico		0.1.0
2001-07					Tdocs N3-010312, N3-010315 agreed at CN#18 – Dresden, Germany	0.1.0	0.2.0
2001-09					Tdocs N3-010462, N3-010427 agreed at CN#19 – Brighton, UK	0.2.0	0.3.0
2001-11					Tdoc N3-010605 agreed at CN#20 – Cancun, Mexico	0.3.0	1.0.0
2002-01					Tdocs N3-020033, N3-020097 agreed at CN#21 – Sophia Antipolis, France	1.0.0	1.1.0
2002-01					Tdoc N3-020098 agreed, subject to correction to Figure 4, at CN#21 – Sophia Antipolis, France	1.1.0	1.2.0
2002-02					DAB, MCC made minor editorials	1.2.0	1.2.1
2002-02					Tdoc N3-020441 agreed at CN#23 – Budapest, Hungary	1.2.1	1.3.1
2002-09					Tdoc N3-020856 agreed at CN#25 – Miami, USA	1.3.1	1.4.1
2003-02					Tdocs N3-030150, N3-030159, N3-030161, N3-030172, N3-030176, N3-030178, N3-030179, N3-030180 and N3-030183 agreed at CN3#27 in Dublin	1.4.1	1.5.0
2003-03					Tdoc N3-030176 agreed at CN3#27 in Dublin	1.5.0	1.5.1
2003-05					Tdocs N3-030252, N3-030356, N3-030357, N3-030363, N3-030393, N3-030394, N3-030402, N3-030408, N3-030409, N3-030414, N3-030415, N3-030439, N3-030440, N3-030441, N3-030442, N3-030443, N3-030444, N3-030445, N3-030457, agreed at CN3#28 in San Diego, USA.	1.5.1	1.6.0
2003-05					Tdocs N3-030419, N3-030420, N3-030453, N3-030462, agreed at CN3#28 in San Diego, USA and some further minor editorial corrections.	1.6.0	1.7.0

Editor: Brendan McWilliams (brendan.mcwilliams@gb.vodafone.co.uk)