

Source: TSG CN WG 1

Title: CRs to R99 (with mirror CRs) on Work Item GSM/UMTS interworking towards 23.009 and 24.007

Agenda item: 7.15

Document for: APPROVAL

Introduction:

This document contains 6 CRs on R99 (with mirror CRs) to Work Item "GSM/UMTS interworking", that have been agreed by TSG CN WG1, and are forwarded to TSG CN Plenary meeting #14 for approval.

Spec	CR	Rev	Phase	Subject	Cat	Version-Current	Version-New	Doc-2nd-Level
23.009	059		R99	E-interface protocol during the supervision phase	F	3.8.0	3.9.0	N1-011806
23.009	060		Rel-4	E-interface protocol during the supervision phase	A	4.2.0	4.3.0	N1-011807
24.007	042	1	R99	Clarification of the send sequence number mechanism	F	3.7.0	3.8.0	N1-011810
24.007	043	1	Rel-4	Clarification of the send sequence number mechanism	A	4.0.0	4.1.0	N1-011811
23.009	056	2	R99	Usage of Location Reporting for Relocation and Inter-system Handover	F	3.8.0	3.9.0	N1-011971
23.009	057	2	Rel-4	Usage of Location Reporting for Relocation and Inter-system Handover	A	4.2.0	4.3.0	N1-011972

3GPP TSG-CN1 Meeting #21
Cancun, Mexico, 26.- 30. November 2001

Tdoc N1-011806
 (also submitted as Tdoc N4-011267)

CR-Form-v5

CHANGE REQUEST

⌘ **23.009 CR 059** ⌘ rev **-** ⌘ Current version: **3.8.0** ⌘

For **HELP** on using this form, see bottom of this page or look at the pop-up text over the ⌘ symbols.

Proposed change affects: ⌘ (U)SIM ME/UE Radio Access Network Core Network

Title:	⌘ E-interface protocol during the supervision phase		
Source:	⌘ Siemens		
Work item code:	⌘ GSM/UMTS interworking	Date:	⌘ 16.11.01
Category:	⌘ F	Release:	⌘ R99
	Use <u>one</u> of the following categories:		Use <u>one</u> of the following releases:
	F (correction)	2 (GSM Phase 2)	
	A (corresponds to a correction in an earlier release)	R96 (Release 1996)	
	B (addition of feature),	R97 (Release 1997)	
	C (functional modification of feature)	R98 (Release 1998)	
	D (editorial modification)	R99 (Release 1999)	
	Detailed explanations of the above categories can be found in 3GPP TR 21.900 .		REL-4 (Release 4)
			REL-5 (Release 5)

Reason for change:	⌘	<p>1) Currently, subclauses 7, 8.1, 8.2, and 8.3 specify general rules about the usage of BSSAP or RANAP on the E-interface during the 'supervision phase'. These rules are in contradiction to other parts of TS 23.009, as</p> <p>i) for subsequent inter-MSC handover the radio access protocol used encapsulated on the E-interface depends only on the serving and the target radio access system, but not on the protocol used on the E-interface during basic inter-MSC handover;</p> <p>ii) a subsequent intra-MSC-B intra GSM or inter-system handover is always indicated with a BSSMAP message (Handover Performed), regardless of the protocol used on the E-interface during basic inter-MSC handover.</p> <p>2) Alignment of message names with the conventions used in the rest of the specification</p> <p>3) Clarification of the protocol interworking scenarios specified in subclauses 11.7 and 12.7.</p>
Summary of change:	⌘	The exceptions to the general rules specified in subclauses 7, 8.1, 8.2 and 8.3. are added to the respective paragraphs.
Consequences if not approved:	⌘	<p>i) Certain cases of subsequent inter-MSC handover are not supported by the standard, like e.g. subsequent inter-MSC SRNS relocation after basic inter-MSC GSM to UMTS inter-system handover.</p> <p>ii) Inconsistent specification with regard to the usage of Handover Performed.</p>

Clauses affected:	⌘	4.2.1, 4.3.1, 4.4.1, 6.2.2, 6.2.3, 7, 8.1, 8.2, 8.3, 10.3, 11.3, 11.7, 12.3, 12.7
Other specs affected:	⌘	<input type="checkbox"/> Other core specifications <input type="checkbox"/> Test specifications <input type="checkbox"/> O&M Specifications
Other comments:	⌘	

How to create CRs using this form:

Comprehensive information and tips about how to create CRs can be found at: http://www.3gpp.org/3G_Specs/CRs.htm. Below is a brief summary:

- 1) Fill out the above form. The symbols above marked ☒ contain pop-up help information about the field that they are closest to.
- 2) Obtain the latest version for the release of the specification to which the change is proposed. Use the MS Word "revision marks" feature (also known as "track changes") when making the changes. All 3GPP specifications can be downloaded from the 3GPP server under <ftp://ftp.3gpp.org/specs/> For the latest version, look for the directory name with the latest date e.g. 2001-03 contains the specifications resulting from the March 2001 TSG meetings.
- 3) With "track changes" disabled, paste the entire CR form (use CTRL-A to select it) into the specification just in front of the clause containing the first piece of changed text. Delete those parts of the specification which are not relevant to the change request.

4.2 MSC-B

4.2.1 Role of MSC-B

In the Intra-MSC handover case, the MSC-B keeps the control of the whole Intra-MSC handover procedure.

MSC-B notifies MSC-A or 3G_MSC-A of successful intra -MSC-B handover completion by using the A_HANDOVER_PERFORMED message.

In the Inter-MSC handover case, the role of MSC-B (MSC-B') is only to provide radio resources control within its area. This means that MSC-B keeps control of the radio resources connection and release towards BSS-B. MSC-B will do some processing on the BSSMAP information received on the E-interface or A-interface whereas it will relay the DTAP information transparently between A-interface and E-interface. MSC-A initiates and drives a subset of BSSMAP procedures towards MSC-B, while MSC-B controls them towards its BSSs to the extent that MSC-B is responsible for the connections of its BSSs. The release of the dedicated resources between MSC-B and BSS-B is under the responsibility of MSC-B and BSS-B, and is not directly controlled by MSC-A. When clearing is to be performed due to information received from BSS-B, MSC-B shall transfer this clearing indication to MSC-A, to clear its connection with BSS-B, to terminate the dialogue with MSC-A through the E-interface, and to release its circuit connection with MSC-A, if any. In the same way, the release of the connection to its BSS-B, is initiated by MSC-B, when the dialogue with MSC-A ends normally and a release is received from the circuit connection with MSC-A, if any, or when the dialogue with the MSC-A ends abnormally.

When a release is received by MSC-B for the circuit connection with MSC-A then MSC-B shall release the circuit connection.

In the Inter-system Inter-MSC handover case, the role of MSC-B (MSC-B') is only to provide radio resources control within its area. This means that MSC-B keeps control of the radio resources connection and release towards BSS-B. MSC-B will do some processing on the BSSMAP information received on the E-interface or A-interface whereas it will relay the DTAP information transparently between A-interface and E-interface. 3G_MSC-A initiates and drives a subset of BSSMAP procedures towards MSC-B, while MSC-B controls them towards its BSSs to the extent that MSC-B is responsible for the connections of its BSSs. The release of the dedicated resources between MSC-B and BSS-B is under the responsibility of MSC-B and BSS-B, and is not directly controlled by 3G_MSC-A. When clearing is to be performed due to information received from BSS-B, MSC-B shall transfer this clearing indication to 3G_MSC-A, to clear its connection with BSS-B, to terminate the dialogue with 3G_MSC-A through the E-interface, and to release its circuit connection with 3G_MSC-A, if any. In the same way, the release of the connection to its BSS-B, is initiated by MSC-B, when the dialogue with 3G_MSC-A ends normally and a release is received from the circuit connection with MSC-A, if any, or when the dialogue with the MSC-A ends abnormally.

When a release is received by MSC-B for the circuit connection with 3G_MSC-A then MSC-B shall release the circuit connection.

***** NEXT MODIFIED SECTION *****

4.3 3G_MSC-A

For roles and functional composition of the 3G_MSC-A working as pure GSM MSC, please see previous clause ("MSC-A").

4.3.1 Role of 3G_MSC-A

In the Intra-3G_MSC handover/relocation case, the 3G_MSC-A (simply termed 3G_MSC) controls the call, the mobility management and the radio resources before, during and after an Intra-3G_MSC handover/relocation. When RANAP or BSSMAP procedures have to be performed, they are initiated and driven by 3G_MSC-A.

In the case of intra-MSC handover of a speech call, 3G_MSC-A controls the transcoder in the core network. The 3G_MSC-A determines if a transcoder is required to be inserted or released in the CN.

In the case of Inter-3G_MSC relocation, 3G_MSC-A links out the transcoder.

In the Inter-3G_MSC relocation case, 3G_MSC-A is the 3G_MSC that controls the call and the mobility management of the UE during the call, before, during and after a basic or subsequent relocation. When RANAP procedures related to dedicated resources have to be performed towards the UE, they are initiated and driven by 3G_MSC-A. The 3G_MSC-A - 3G_MSC-B interface works as a 3G_MSC - RNS interface for the RANAP procedures. The Direct Transfer signalling is relayed transparently by 3G_MSC-B between 3G_MSC-A and the UE.

During a successful relocation the order to perform location reporting at change of Service Area is not transferred to the target RNS. In the Intra-3G_MSC-A relocation case, the 3G_MSC-A re-issues the Location Reporting Control towards the target RNS. In the Inter-3G_MSC relocation case, 3G_MSC-A keeps the control of the Location Report Control procedure. However, re-issuing the ~~Iu-LOCATION-REPORTING-CONTROL~~ Location Reporting Control messages due to subsequent Intra-3G_MSC-B relocations is the responsibility of 3G_MSC-B.

During a basic relocation, 3G_MSC-A initiates and controls all the relocation procedure, from its initiation (reception of Relocation Required from RNS-A on Iu-interface) until its completion (reception of Relocation Complete from 3G_MSC-B on E-interface).

During a subsequent relocation back to 3G_MSC-A, 3G_MSC-A acts as an RNS towards 3G_MSC-B, which controls the relocation procedure until the termination in 3G_MSC-A of the handover radio resources allocation (sending of the Relocation Request Acknowledge to 3G_MSC-B from 3G_MSC-A). Then all relocation related messages shall terminate at 3G_MSC-A (e.g. Relocation Detect/Complete from RNS-B, Relocation Cancel from RNS-A).

During a subsequent relocation to a third 3G_MSC, 3G_MSC-A works towards 3G_MSC-B' as described above in the basic relocation paragraph and towards 3G_MSC-B as described above in subsequent relocation paragraph.

In the Inter-System, inter-3G_MSC handover case, 3G_MSC-A is the 3G_MSC which controls the call and the mobility management of the UE/MS during the call, before, during and after a basic or subsequent inter-system handover. When BSSAP procedures related to dedicated resources have to be performed towards the UE/MS, they are initiated and driven by 3G_MSC-A. The 3G_MSC-A - MSC-B interface works as a 3G_MSC - BSS interface for a subset of BSSMAP procedures. These BSSMAP procedures described in 3GPP TS 09 08 [7] are those related to dedicated resources. The DTAP signalling is relayed transparently by MSC-B between 3G_MSC-A and the UE/MS.

During a basic inter-system UMTS to GSM handover, 3G_MSC-A initiates and controls all the handover procedure, from its initiation (reception of Relocation Required from RNS-A on Iu-interface) until its completion (reception of Handover Complete from MSC-B on E-interface).

During a subsequent inter-system UMTS to GSM handover back to 3G_MSC-A, 3G_MSC-A acts as a BSS towards 3G_MSC-B, which controls the handover procedure until the termination in 3G_MSC-A of the handover radio resources allocation (sending of the Handover Request Acknowledge to 3G_MSC-B from 3G_MSC-A). Then all handover related messages shall terminate at 3G_MSC-A (e.g. Handover Detect/Complete from BSS-B, Relocation Cancel from RNS-A).

During a subsequent inter-system UMTS to GSM handover to a third 3G_MSC, 3G_MSC-A works towards MSC-B' as described above in the basic inter-system handover paragraph and towards 3G_MSC-B as described above in subsequent inter-system handover paragraph.

During a basic inter-system GSM to UMTS handover, 3G_MSC-A initiates and controls all the handover procedure, from its initiation (reception of Handover Required from BSS-A on A-interface) until its completion (reception of Handover Complete from 3G_MSC-B on E-interface).

During a subsequent inter-system GSM to UMTS handover back to 3G_MSC-A, 3G_MSC-A acts as an RNS towards MSC-B, which controls the handover procedure until the termination in 3G_MSC-A of the handover radio resources allocation (sending of the Handover Request Acknowledge to MSC-B from 3G_MSC-A). Then all handover related messages shall terminate at 3G_MSC-A (e.g. Relocation Detect/Complete from RNS-B, Handover Failure from BSS-A).

During a subsequent inter-system GSM to UMTS handover to a third 3G_MSC, 3G_MSC-A works towards 3G_MSC-B' as described above in the basic inter-system handover paragraph and towards MSC-B as described above in subsequent inter-system handover paragraph.

If 3G_MSC-A supports the optional supplementary service Multicall (See 3GPP TS 23.135) and UE is engaged with multiple bearers the following description applies;

- In the Intra-3G_MSC relocation case, the 3G-MSC-A tries to relocate all bearers to a new RNS.

- In the basic relocation case, the 3G-MSC-A tries to relocate all bearers to 3G_MSC-B. If 3G_MSC-A receives an indication that the 3G_MSC-B does not support multiple bearers, then 3G_MSC-A shall be able to select one bearer to be handed over according to the priority level defined as RAB parameters in 3GPP TS 25.413 and tries again to relocate the selected bearer.
- In the subsequent relocation to a third 3G_MSC-B' case, the 3G-MSC-A tries to relocate all bearers to 3G_MSC-B'. If 3G_MSC-A receives an indication that the 3G_MSC-B' does not support multiple bearers, then 3G_MSC-A shall be able to select one bearer to be handed over according to the priority level defined as RAB parameters in 3GPP TS 25.413 [11] and tries again to relocate the selected bearer.
- In the Intra-3G_MSC inter-system UMTS to GSM handover case and the basic inter-system UMTS to GSM handover case, the 3G_MSC-A shall be able to select one bearer to be handed over according to the priority level defined as RAB parameters in 3GPP TS 25.413 [11] and tries to handover the selected bearer.
- In all cases described above, 3G_MSC-A shall release some calls which has been carried by the bearers failed to set up in new RNS or the bearers not to be handed over.

***** NEXT MODIFIED SECTION *****

4.4 3G_MSC-B

For roles and functional composition of the 3G_MSC-B working as pure GSM MSC, please see previous clause ("MSC-B").

4.4.1 Role of 3G_MSC-B

In the Intra-3G_MSC handover/relocation case, the 3G_MSC-B keeps the control of the whole Intra-3G_MSC handover/relocation procedure. 3G_MSC-B notifies MSC-A or 3G_MSC-A of intra-3G_MSC-B InterSystem handover and intra GSM handovers, by using the A_HANDOVER_PERFORMED message.

In case of intra-3G_MSC-B SRNS relocation, if security algorithms have been changed then:

- a) When encapsulated BSSAP is used on the E interface, the A_HANDOVER_PERFORMED message shall be sent.
- b) When encapsulated RANAP is used on the E interface, the Iu-LOCATION_REPORT message shall be sent.

On reception of an order to perform location reporting at change of Service Area from 3G_MSC-A, 3G_MSC-B shall be responsible to re-issue the Iu-LOCATION-REPORTING-CONTROL message after subsequent Intra-3G_MSC-B relocations/handovers. This shall be performed immediately after the successful completion of the Relocation Resource Allocation procedure.

In both cases, the selected UMTS algorithm(s) shall be indicated in the MAP_PROCESS_ACCESS_SIGNALLING_REQUEST request.

The role of 3G_MSC-B is also to provide transcoder resources.

In the Inter-3G_MSC relocation case, the role of 3G_MSC-B (3G_MSC-B') is only to provide radio resources control within its area. This means that 3G_MSC-B keeps control of the radio resources connection and release towards RNS-B. 3G_MSC-B will do some processing on the RANAP information received on the E-interface or the RANAP information received on the Iu-interface whereas it will relay the Direct Transfer information transparently between Iu-interface and E-interface. 3G_MSC-A initiates and drives RANAP procedures towards 3G_MSC-B, while 3G_MSC-B controls them towards its RNSs to the extent that 3G_MSC-B is responsible for the connections of its RNSs. The release of the dedicated resources between 3G_MSC-B and RNS-B is under the responsibility of 3G_MSC-B and RNS-B, and is not directly controlled by 3G_MSC-A. When clearing is to be performed due to information received from RNS-B, 3G_MSC-B shall transfer this clearing indication to 3G_MSC-A, to clear its connection with RNS-B, to terminate the dialogue with 3G_MSC-A through the E-interface, and to release its circuit connection with 3G_MSC-A, if any. In the same way, the release of the connection to its RNS-B, is initiated by

3G_MSC-B, when the dialogue with 3G_MSC-A ends normally and a release is received from the circuit connection with 3G_MSC-A, if any, or when the dialogue with the 3G_MSC-A ends abnormally.

When a release is received by 3G_MSC-B for the circuit connection with 3G_MSC-A then 3G_MSC-B shall release the circuit connection.

In the Inter-system UMTS to GSM Inter-3G_MSC handover case, the role of 3G_MSC-B (3G_MSC-B') is only to provide radio resources control within its area. This means that 3G_MSC-B keeps control of the radio resources connection and release towards BSS-B. 3G_MSC-B will do some processing on the BSSMAP information received on the E-interface or the BSSMAP information received on the A-interface whereas it will relay the DTAP information transparently between A-interface and E-interface. 3G_MSC-A initiates and drives a subset of BSSMAP procedures towards 3G_MSC-B, while 3G_MSC-B controls them towards its BSSs to the extent that 3G_MSC-B is responsible for the connections of its BSSs. The release of the dedicated resources between 3G_MSC-B and BSS-B is under the responsibility of 3G_MSC-B and BSS-B, and is not directly controlled by 3G_MSC-A. When clearing is to be performed due to information received from BSS-B, 3G_MSC-B shall transfer this clearing indication to 3G_MSC-A, to clear its connection with BSS-B, to terminate the dialogue with 3G_MSC-A through the E-interface, and to release its circuit connection with MSC-A, if any. In the same way, the release of the connection to its BSS-B, is initiated by 3G_MSC-B, when the dialogue with 3G_MSC-A ends normally and a release is received from the circuit connection with 3G_MSC-A, if any, or when the dialogue with the MSC-A ends abnormally.

When a release is received by 3G_MSC-B for the circuit connection with 3G_MSC-A then 3G_MSC-B shall release the circuit connection.

In the Inter-system GSM to UMTS Inter-3G_MSC handover case, the role of 3G_MSC-B (3G_MSC-B') is only to provide radio resources control within its area. This means that 3G_MSC-B keeps control of the radio resources connection and release towards RNS-B. 3G_MSC-B will do some processing on the BSSMAP information received on the E-interface or the RANAP information received on the Iu-interface whereas it will relay the Direct Transfer information transparently between Iu-interface and E-interface. MSC-A initiates and drives a subset of BSSMAP procedures towards 3G_MSC-B, while 3G_MSC-B controls them towards its RNSs to the extent that 3G_MSC-B is responsible for the connections of its RNSs. The release of the dedicated resources between 3G_MSC-B and RNS-B is under the responsibility of 3G_MSC-B and RNS-B, and is not directly controlled by MSC-A. When clearing is to be performed due to information received from RNS-B, 3G_MSC-B shall transfer this clearing indication to MSC-A, to clear its connection with RNS-B, to terminate the dialogue with MSC-A through the E-interface, and to release its circuit connection with MSC-A, if any. In the same way, the release of the connection to its RNS-B, is initiated by 3G_MSC-B, when the dialogue with MSC-A ends normally and a release is received from the circuit connection with MSC-A, if any, or when the dialogue with the MSC-A ends abnormally.

When a release is received by 3G_MSC-B for the circuit connection with MSC-A then 3G_MSC-B shall release the circuit connection.

If 3G_MSC-B does not support the optional supplementary service Mutlicall (See 3GPP TS 23.135) and 3G_MSC-A requests to relocate multiple bearers, 3G_MSC-B shall indicate that it does not support multiple bearers to 3G_MSC-A.

If 3G_MSC-B supports the optional supplementary service Multicall (See 3GPP TS 23.135) and UE is engaged with multiple bearers the following description applies;

- In the basic relocation case, the 3G_MSC-B shall be able to allocate an Handover Number for each bearer. The 3G-MSC-B shall also be able to select some bearers so that the number of bearers will fulfill the maximum number of bearers supported by the 3G_MSC-B.
- In the Intra-3G_MSC relocation case, the 3G-MSC-B tries to relocate all bearers to a new RNS.
- In the subsequent relocation back to the 3G_MSC-A or to a third 3G_MSC-B' case, the 3G-MSC-B tries to request to the 3G_MSC-A to relocate all bearers to the 3G_MSC-A or to the 3G_MSC-B'.
- In the Intra-3G_MSC inter-system UMTS to GSM handover case and the subsequent inter-system UMTS to GSM handover back to the 3G_MSC-A or to a third MSC-B' case, the 3G_MSC-B shall be able to select one bearer to be handed over according to the priority level defined as RAB parameters in 3GPP TS 25.413 [11] and tries to handover the selected bearer.

***** NEXT MODIFIED SECTION *****

6.2.2 Intra-3G_MSC GSM to UMTS Handover

The procedure for a successful Intra-3G_MSC handover is shown in figure 9. It is assumed that selection of a candidate UE/MS has already taken place within the BSC based upon the criteria presented in clause 5. The exact algorithm, in the BSC, for determining a candidate UE/MS is not addressed in the present document. The procedures discussed do not make use of the Mobile Application Part (MAP), represented by signalling function 4 in figures 4 and 6. The procedure described in this subclause covers case ii).

In case of subsequent handover the following applies. If 3G_MSC-B supports location reporting at change of Service Area and if encapsulated BSSAP signalling is used on the E-interface, 3G_MSC-B shall always initiate the Location Reporting Control procedure at change of Service Area towards the target RNS since no request for Location Reporting can be received from MSC-A. In that case, the Location Reporting Control procedure shall be initiated by 3G_MSC-B after the Relocation Resource Allocation procedure has been executed successfully.

The change of Service Area shall be reported to MSC-A within an A_HANOVER_PERFORMED message.

In the case of ongoing voice group calls, the handover does not take place since voice group calls are not supported in UMTS.

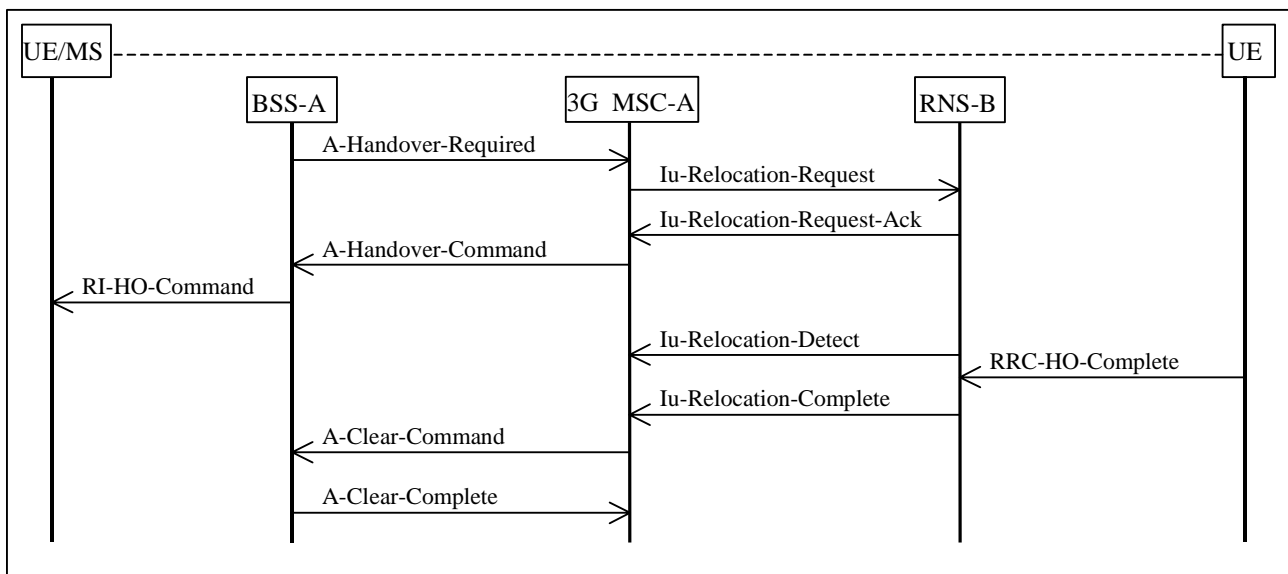

Figure 9: Basic External Intra-3G_MSC GSM to UMTS Handover Procedure

The successful operation of the procedure is as follows. When the BSS (BSS-A), currently supporting the UE, determines that the UE requires to be handed over to UMTS it will send an A-HANDOVER-REQUIRED message to the 3G_MSC (3G_MSC-A). The A-HANDOVER-REQUIRED message shall contain a single cell, to which the UE can be handed over. When the 3G_MSC-A receives the A-HANDOVER-REQUIRED message it shall begin the process of handing over the UE to a new RNS (RNS-B). The 3G_MSC-A shall generate an Iu-RELOCATION-REQUEST message to the selected RNS (RNS-B). When RNS-B receives the Iu-RELOCATION-REQUEST message it shall take the necessary action to allow the UE to access the radio resource of RNS-B, this is detailed in the 3GPP TS 25.300 series and the 3GPP TS 25.200 series of Technical Specifications. The switching of the radio resource through the necessary terrestrial resources is detailed in the 3GPP TS 25.430 series and 3GPP TS 25.413 [11].

Once resource allocation has been completed by RNS-B, it shall return an Iu-RELOCATION-REQUEST-ACK. to 3G_MSC-A. When this message is received by 3G_MSC-A it shall begin the process of instructing the UE to tune to a new dedicated radio resource. An A-HANDOVER-COMMAND will be sent by the 3G_MSC-A to BSS-A. On receipt of the A-HANDOVER-COMMAND message BSS-A will send the radio interface message RI-HANDOVER-COMMAND. The UE will then access the new radio resource. On detection of the UE, the RNS-B shall send an Iu-RELOCATION-DETECT to 3G_MSC-A. When the UE is successfully communicating with the RNS-B an RRC-HANDOVER-COMplete message will be sent by the UE to RNS-B. The RNS-B will then send an Iu-RELOCATION-COMplete message to 3G_MSC-A.

NOTE: The Iu-RELOCATION-REQUEST-ACK from RNS-B contains the complete RRC message that shall be sent by BSS-A to the MS in the RI-HANDOVER-COMMAND, 3G_MSC-A transparently passes this radio interface message onto BSS-A.

After 3G_MSC-A has received the Iu-RELOCATION-COMplete message from RNS-B, it shall begin to release the resources allocated on BSS-A. In figure 9 the resource is released by using the A-CLEAR-COMMAND sequence.

If a failure occurs during the handover attempt, for example, A-HANDOVER-FAILURE returned from BSS-A or Iu-RELOCATION FAILURE returned from RNS-B, then 3G_MSC-A will terminate the handover to RNS-B. Under these conditions 3G_MSC-A may optionally take one of a number of actions:

- i) await the next A-HANDOVER-REQUIRED message;
- ii) send an A-HANDOVER-REQUIRED-REJECT to BSS-A, if an A-HANDOVER-COMMAND has not already been sent.

The exact action taken is dependent on whether the failure occurs before or after the A-HANDOVER-COMMAND has been sent.

In all cases the existing connection to the UE shall not be cleared.

During the period that the UE is not in communication with the network 3G_MSC-A shall queue all appropriate messages. All messages shall be delivered to the UE once communication is resumed. In the case of an Intra-3G_MSC GSM to UMTS handover on 3G_MSC-B then the messages shall be queued by 3G_MSC-B.

6.2.3 Procedure for Intra-3G_MSC SRNS Relocation

The procedure for a successful Intra-3G_MSC SRNS Relocation is shown in figures 10 and 11. SRNS Relocation is used to relocate the serving RNS functionality from one RNS to another. The procedure may or may not involve change of the radio resources assigned for the corresponding UE. Whether or not the Relocation includes change of radio resources assigned for the UE does not affect the SRNS Relocation procedure in the Core Network.

In case of subsequent Intra-3G_MSC-B SRNS relocation the following applies:

- If 3G_MSC-B has previously received an order to perform location reporting at change of Service Area from 3G_MSC-A and if 3G_MSC-B also supports Location Reporting Control, it shall issue the Iu-LOCATION-REPORTING-CONTROL message towards the target RNS immediately after successful completion of relocation. Upon receipt of Iu-LOCATION-REPORT, 3G_MSC-B shall forward it towards 3G_MSC-A via E interface.
- If 3G_MSC-B supports location reporting at change of Service Area and if encapsulated BSSAP signalling is used on the E-interface, 3G_MSC-B shall always initiate the Location Reporting Control procedure at change of Service Area towards the target RNS, since no request for Location Reporting can be received from MSC-A. In that case the Location Reporting Control procedure shall be initiated by 3G_MSC-B after the Relocation Resource Allocation procedure has been executed successfully. The change of Service Area shall be reported to MSC-A within an A-HANDOVER-PERFORMED message.

It is assumed that selection of a candidate UE has already taken place within RNS based upon the criteria presenting in clause 5. The exact algorithm, in RNS, for determining a candidate UE is not addressed in the present document. The procedure discussed does not make use of the Mobile Application Part (MAP), represented by signalling function 4 in figures 4 and 6. The procedure described in this subclause covers case ii).

***** NEXT MODIFIED SECTION *****

7 General description of the procedures for inter - MSC handovers

The following subclauses describe two options for the Basic and Subsequent Handover procedures. The first, as described in subclauses 7.1 and 7.3 respectively, provides for a circuit connection between MSC-A and MSC-B. The second, as described in subclauses 7.2 and 7.4 respectively, provides for a Basic and Subsequent Handover without the provision of a circuit connection between MSC-A and MSC-B.

In all the above mentioned subclauses, the following principles apply:

- during the handover resource allocation, only the handover related messages that are part of the applicable BSSAP subset - as defined in 3GPP TS 09.08 [7] - shall be transferred on the E-interface;
- the trace related messages that are part of the applicable BSSAP subset - as defined in 3GPP TS 09.08 [7] - can be sent by the MSC-A on the E-interface after successful handover resource allocation. In the subclauses 7.1 and 7.2, it is however allowed at basic handover initiation on the E-Interface to transfer one trace related message that is part of the applicable BSSAP subset - as defined in 3GPP TS 09.08 [7] - together with the applicable handover related message. The applicable handover related message shall always appear as the first message;
- during the handover execution, ie while the MS is not in communication with the network, the MSC-A shall queue all outgoing BSSAP messages until the communication with the MS is resumed;
- finally, during supervision, ie while the MS is not in the area of MSC-A after a successful Inter-MSC handover, the subset of BSSAP procedures and their related messages - as defined in 3GPP TS 09.08 [7] - shall apply on the E-Interface; As the only exception to this rule, in case of a subsequent inter-MSC SRNS relocation back to 3G MSC-A or to a third 3G MSC-B' the Relocation Resource Allocation procedure as specified in 3GPP TS 29.108 [15] shall apply (see subclause 8.3, first list item).

NOTE: A subsequent inter-MSC SRNS relocation back to 3G MSC-A or to a third 3G MSC-B' can occur, e.g., if after the basic inter-MSC handover to 3G MSC-B the MS performed a subsequent intra-3G MSC-B GSM to UMTS inter-system handover;

- during the intra-MSC-B handover execution, if any, the MSC-B shall queue all outgoing BSSAP messages until the communication with the MS is resumed.

***** NEXT MODIFIED SECTION *****

8 General Description of the procedures for inter - 3G_MSC handovers

8.1 Handover UMTS to GSM

The following subclauses describe two options for the Basic and Subsequent UMTS to GSM Handover procedures. The first, as described in subclauses 8.1.1 and 8.1.3 respectively, provides for a circuit connection between 3G_MSC-A and 3G_MSC-B. The second, as described in subclauses 8.1.2 and 8.1.4 respectively, provides for a Basic and Subsequent Handover without the provision of a circuit connection between 3G_MSC-A and 3G_MSC-B. 3G_MSC can also be a pure GSM MSC.

In all the above mentioned subclauses, the following principles apply:

- during the handover resource allocation, only the handover related messages that are part of the applicable BSSAP subset - as defined in 3GPP TS 09.08 [7] - shall be transferred on the E-interface;
- the trace related messages that are part of the applicable BSSAP subset - as defined in 3GPP TS 09.08- can be sent by the 3G_MSC-A on the E-interface after successful handover resource allocation. In the subclauses 8.1.1 and 8.1.2, it is however allowed at basic handover initiation on the E-Interface to transfer one trace related message that is part of the applicable BSSAP subset - as defined in 3GPP TS 09.08 [7] - together with the applicable handover related message. The applicable handover related message shall always appear as the first message;
- during the handover execution, i.e. while the UE/MS is not in communication with the network, the 3G_MSC-A shall queue all outgoing BSSAP/Direct Transfer messages until the communication with the UE/MS is resumed;
- finally, during supervision, i.e. while the UE/MS is not in the area of 3G_MSC-A after a successful Inter-3G_MSC handover, the subset of BSSAP procedures and their related messages - as defined in 3GPP TS 09.08 [7] - shall apply on the E-Interface; As the only exception to this rule, in case of a subsequent inter-MSC SRNS relocation back to 3G_MSC-A or to a third 3G_MSC-B' the Relocation Resource Allocation procedure as specified in 3GPP TS 29.108 [15] shall apply (see subclause 8.3, first list item).

NOTE: A subsequent inter-MSC SRNS relocation back to 3G_MSC-A or to a third 3G_MSC-B' can occur, e.g., if after the basic inter-MSC handover to 3G_MSC-B the MS performed a subsequent intra-3G_MSC-B GSM to UMTS inter-system handover;

- during the intra-3G_MSC -B handover execution, if any, the 3G_MSC -B shall queue all outgoing BSSAP messages until the communication with the UE/MS is resumed.

***** NEXT MODIFIED SECTION *****

8.2 Handover GSM to UMTS

The following subclauses describe two options for the Basic and Subsequent GSM to UMTS Handover procedures. The first, as described in subclauses 8.2.1 and 8.2.3 respectively, provides for a circuit connection between (3G_)MSC-A and (3G_)MSC-B. The second, as described in subclauses 8.2.2 and 8.2.4 respectively, provides for a Basic and Subsequent Handover without the provision of a circuit connection between (3G_)MSC-A and (3G_)MSC-B. In all the above mentioned subclauses, the following principles apply:

- during the handover resource allocation, only the handover related messages that are part of the applicable BSSAP subset - as defined in 3GPP TS 09.08 [7] - shall be transferred on the E-interface;
- the trace related messages that are part of the applicable BSSAP subset - as defined in 3GPP TS 09.08 [7] - can be sent by the MSC-A on the E-interface after successful handover resource allocation. In the subclauses 8.2.1 and 8.2.2, it is however allowed at basic handover initiation on the E-Interface to transfer one trace related message that is part of the applicable BSSAP subset - as defined in 3GPP TS 09.08 [7] - together with the applicable handover related message. The applicable handover related message shall always appear as the first message;
- If 3G_MSC-B or 3G-MSC-B' supports location reporting at change of Service Area, 3G_MSC-B or 3G_MSC-B' shall always initiate the Location Reporting Control procedure at change of Service Area towards the target RNS since no request for Location Reporting can be received from MSC-A. In that case, the Location Reporting Control procedure shall be initiated by 3G_MSC-B or 3G-MSC-B' after the Relocation Resource Allocation procedure has been executed successfully. The change of Service Area shall be reported to MSC-A within an A_HANOVER_PERFORMED message.
- during the handover execution, i.e. while the UE/MS is not in communication with the network, the MSC-A shall queue all outgoing BSSAP messages until the communication with the UE/MS is resumed;
- finally, during supervision, i.e. while the UE/MS is not in the area of MSC-A after a successful Inter-3G_MSC GSM to UMTS handover, the subset of BSSAP procedures and their related messages - as defined in 3GPP TS 09.08 [7] - shall apply on the E-Interface;. As the only exception to this rule, in case of a subsequent inter-MSC SRNS relocation back to 3G_MSC-A or to a third 3G_MSC-B' the Relocation Resource Allocation procedure as specified in 3GPP TS 29.108 [15] shall apply (see subclause 8.3, first list item);
- during the intra-3G_MSC-B GSM to UMTS handover execution, if any, the 3G_MSC-B shall queue all outgoing Direct Transfer messages until the communication with the UE/MS is resumed.

***** NEXT MODIFIED SECTION *****

8.3 SRNS Relocation

The following subclauses describe two options for the Basic and Subsequent Relocation procedures. The first, as described in subclauses 8.3.1 and 8.3.3 respectively, provides for a circuit connection between 3G_MSC-A and 3G_MSC-B. The second, as described in subclauses 8.3.2 and 8.3.4 respectively, provides for a Basic and Subsequent Relocation without the provision of a circuit connection between 3G_MSC-A and 3G_MSC-B.

In all the above mentioned subclauses, the following principles apply:

- during the relocation resource allocation, only the handover related messages that are part of the applicable RANAP subset - as defined in 3GPP TS 29.108 [15] - shall be transferred on the E-interface;
- the trace related messages that are part of the applicable RANAP subset - as defined in 3GPP TS 29.108 [15] - can be sent by the 3G_MSC-A on the E-interface after successful relocation resource allocation. In the

subclauses 8.3.1 and 8.3.2, it is however allowed at basic relocation initiation on the E-Interface to transfer one trace related message that is part of the applicable RANAP subset - as defined in 3GPP TS 29.108 [15] - together with the applicable relocation related message. The applicable relocation related message shall always appear as the first message;

- during the relocation execution, i.e. while the UE is not in communication with the network, the 3G_MSC-A shall queue all outgoing RANAP messages until the communication with the UE is resumed;
- finally, during supervision, i.e. while the UE is not in the area of 3G_MSC-A after a successful Inter-3G_MSC relocation, the subset of RANAP procedures and their related messages - as defined in 3GPP TS 29.108 [15] - shall apply on the E-Interface; As an exception to this rule, 3G_MSC-B shall notify 3G_MSC-A of a successfully completed subsequent intra-MSC-B intra GSM or inter-system handover by using the Internal Handover Indication procedure as specified in 3GPP TS 09.08 [7]. Furthermore, in case of a subsequent inter-MSC intra GSM or inter-system handover back to 3G_MSC-A or to a third 3G_MSC-B' the Handover Resource Allocation procedure as specified in 3GPP TS TS 09.08 [7] shall apply (see first list item in clause 7, subclause 8.1, and 8.2, respectively).

NOTE: A subsequent inter-MSC intra GSM or GSM to UMTS inter-system handover back to 3G_MSC-A or to a third 3G_MSC-B' can occur, e.g., if after the basic inter-MSC SRNS relocation to 3G_MSC-B the MS performed a subsequent intra-3G_MSC-B UMTS to GSM inter-system handover;

- during the intra-3G_MSC-B relocation execution, if any, the 3G_MSC-B shall queue all outgoing RANAP messages until the communication with the UE is resumed.
- after successful completion of the Intra-3G_MSC-B relocation, if 3G_MSC-B or 3G-MSC-B' has previously received an order to perform location reporting at change of Service Area from 3G_MSC-A, it shall act as specified in subclause 6.2.3.

***** NEXT MODIFIED SECTION *****

10.3 Handover control procedures MSC-B (functional unit 3)

The procedures of functional unit 3 are given in form of SDL diagrams in figure 42. To easily distinguish the interface concerned the messages received or sent from this unit are prefixed with either 'MAP' for a MAP message, 'A' for an A-Interface message or 'I' for an ISDN/PSTN message. The procedure in functional unit 3 include:

- i) handover from MSC-A.

This case is initiated by MSC-A, and includes allocation and establishment of the new radio channel. The procedure is outlined in subclauses 7.1. and 7.2.

- ii) intra-MSC handovers within the area controlled by MSC-B.

This procedure is the same as that of i) in subclause 9.3, except that the A-HANDOVER-REQUIRED is received by MSC-B. After successful completion of the intra-MSC handover, MSC-B shall notify MSC-A by sending an A-HANDOVER-PERFORMED message.

- iii) subsequent handover to another MSC (MSC-A or MSC-B').

The initiation procedure is essentially the same as that of i) of subclause 9.3. The Handover Command to the MS is now generated by MSC-B after the A-HO-REQUEST-ACKNOWLEDGE is received from MSC-A (via functional unit 4). The procedure is terminated in MSC-B when MSC-B receives a terminate procedure indication from functional unit 4.

Timers in MSC-B.

The following procedures are supervised by timers in order to avoid a deadlock when responses are not received or the procedures fail.

The following timers are defined:

- T201: this timer supervises the queuing time for a free channel. T201 is set by O&M;
- T202: this timer supervises the time for handover completion for handover between BSSs in MSC-B. If T202 expires, the radio path and the connection on interface B' are released. T202 is set by O&M;
- T204: this timer supervises the time between sending of address complete message to MSC-A and receiving the A-HANDOVER-COMPLETE from BSS-B on MSC-B. This timer also supervises the time between issuing the handover command to the MS and receiving the MAP-SEND-END-SIGNAL response from MSC-A, for a subsequent handover. In the case of a handover without circuit connection between MSC-A and MSC-B this timer supervises the time between issuing the A-HO-REQUEST-ACKNOWLEDGE to the MSC-A and receiving the A-HANDOVER-COMPLETE from BSS-B on MSC-B. If the timer expires, then any new radio channel is released. T204 is set by O&M;
- T210: this timer is used to supervise the time for establishing a circuit connection from MSC-A to MSC-B. When T210 expires, the allocated channel in MSC-B is released. T210 is set by O&M. This timer is not started when MSC-A explicitly indicates that no handover number is needed;
- T211: this timer is used to control the time between requesting a subsequent handover (A-HO-REQUEST to the MSC-A) and receiving the response from MSC-A (A-REQUEST-ACKNOWLEDGE/A-HO-FAILURE). If T211 expires, the existing connection with the MS is maintained. T211 is set by O&M.

***** NEXT MODIFIED SECTION *****

11.3 Handover/Relocation control procedures 3G_MSC-A (functional unit 3)

The procedures of functional unit 3 are given in terms of SDL diagrams in figure 43. To easily distinguish the interface concerned the messages received or sent from this unit are prefixed with either 'MAP' for a MAP message, 'A' for an A-Interface message, 'I' for an ISDN/PSTN message or 'Iu' for an Iu-message.

The procedures of functional unit 3 include:

- i) initiation. The initiation condition is shown by the signal Iu-RELOCATION-REQUIRED or A-HANDOVER-REQUIRED;

The diagram also includes queuing when there is no channel available. Calls for which handover/relocation has been initiated should be queued with priority higher than normal calls. They should have lower priority than emergency calls.

- ii) handover/relocation of calls within the area of 3G_MSC-A, i.e. handover/relocation case i);

In the handover/relocation from RNS-A/BSS-A to RNS-B/BSS-B 3G_MSC-A controls the procedures on both the previous and the new radio channel, using signals Iu-RELOCATION-REQUEST/A-HANDOVER-REQUEST and Iu-RELOCATION-COMMAND/A-HANDOVER-COMMAND. The handover/relocation procedure is completed when Iu-RELOCATION-COMPLETE/A-HANDOVER-COMPLETE is received. If this signal is not received, the radio path and the connection on interface B' are either released or the original connection is maintained.

For handover/relocation devices with three-party capabilities the device is first set up so that all interfaces Iu'A', Iu'A" and B' are connected (illustrated by the signal 'set up handover device'). This is done when the Relocation Command is sent to serving RNS or Handover Command is sent to the serving BSS. The device is connected in its final position (i.e. Iu'A" to B' for case ii)) (illustrated by the signal 'connect handover device') when Iu-RELOCATION-COMPLETE/A-HANDOVER-COMPLETE is received.

- iii) relocation to 3G_MSC-B. This procedure is the one described in subclauses 8.3.1 and 8.3.2. For handover/relocation devices with three-party capabilities the device is set-up when 3G_MSC-A sends the Relocation Command to the UE, i.e. the interfaces Iu', B' and B" are then connected. The device is connected in its final position (i.e. B' to B") when the successful procedure indication is received from functional unit 4;

- iv) UMTS to GSM handover to MSC-B. This procedure is the one described in subclauses 8.1.1 and 8.1.2. For handover/relocation devices with three-party capabilities the device is set-up when 3G_MSC-A sends the Relocation Command to the serving RNS, i.e. the interfaces Iu', B' and B'' are then connected. The device is connected in its final position (i.e. B' to B'') when the successful procedure indication is received from functional unit 4;
- v) GSM to UMTS handover to 3G_MSC-B. This procedure is the one described in subclauses 8.2.1 and 8.2.2. For handover/relocation devices with three-party capabilities the device is set-up when MSC-A sends the Handover Command to the serving BSS, i.e. the interfaces A', B' and B'' are then connected. The device is connected in its final position (i.e. B' to B'') when the successful procedure indication is received from functional unit 4;
- vi) subsequent relocation from 3G_MSC-B to 3G_MSC-A. The procedure is described in subclauses 8.3.3.1 and 8.3.4.1. When a relocation to 3G_MSC-A indication is received from functional unit 4, the handover/relocation device is set up so that interfaces B', B'' and Iu' are connected (for devices with three-party capabilities). When Iu-RELOCATION-COMPLETE is received, the device is connected in its final position (i.e. B' to Iu');

If Iu-RELOCATION-COMPLETE is not received (expiry of timer T704), the handover/relocation device releases interface Iu' and returns to a position where B' and B'' are connected.

- vii) subsequent GSM to UMTS handover from MSC-B to 3G_MSC-A. The procedure is described in subclauses 8.2.3.1 and 8.2.4.1. When a handover to 3G_MSC-A indication is received from functional unit 4, the handover device is set up so that interfaces B', B'' and A' are connected (for handover devices with three-party capabilities). When IuA-RELOCATION-COMPLETE is received, the device is connected in its final position (i.e. B' to Iu');

If IuA-RELOCATION-COMPLETE is not received (expiry of timer T504), the device releases interface Iu' and returns to a position where B' and B'' are connected.

- viii) subsequent UMTS to GSM handover from 3G_MSC-B to MSC-A. The procedure is described in subclauses 8.1.3.1 and 8.1.4.1. When a handover to MSC-A indication is received from functional unit 4, the handover device is set up so that interfaces B', B'' and Iu' are connected (for handover devices with three-party capabilities). When A-HANDOVER-COMPLETE is received, the device is connected in its final position (i.e. B' to A');

If A-HANDOVER-COMPLETE is not received (expiry of timer T304), the device releases interface A' and returns to a position where B' and B'' are connected.

- ix) subsequent relocation from 3G_MSC-B to a third 3G_MSC (3G_MSC-B'). The procedure is described in subclauses 8.3.4.2 and 8.3.5.2. The handover/relocation device is set up in its initial position, (i.e. interconnection of interfaces B', B'' and B''') when the connection to 3G_MSC-B' has been established. 3G_MSC-B is informed via functional unit 4 that the connection has been established and that the procedure on the radio path can be initiated. The device is connected in its final position (i.e. B' to B''') when a successful procedure indication is received from functional unit 4. 3G_MSC-B is informed that all procedures in 3G_MSC-B can be terminated (illustrated by the MAP-SEND-END-SIGNAL response). The device returns to the state where B' and B'' are connected if the subsequent relocation procedure fails;
- x) subsequent UMTS to GSM handover from 3G_MSC-B to a third MSC (MSC-B'). The procedure is described in subclauses 8.1.3.2 and 8.1.4.2. The handover/relocation device is set up in its initial position, (i.e. interconnection of interfaces B', B'' and B''') when the connection to MSC-B' has been established. 3G_MSC-B is informed via functional unit 4 that the connection has been established and that the procedure on the radio path can be initiated. The device is connected in its final position (i.e. B' to B''') when a successful procedure indication is received from functional unit 4. 3G_MSC-B is informed that all procedures in 3G_MSC-B can be terminated (illustrated by the MAP-SEND-END-SIGNAL response). The device returns to the state where B' and B'' are connected if the subsequent UMTS to GSM handover procedure fails;
- xi) subsequent GSM to UMTS handover from MSC-B to a third MSC (3G_MSC-B'). The procedure is described in subclauses 8.2.3.2 and 8.2.4.2. The handover/relocation device is set up in its initial position, (i.e. interconnection of interfaces B', B'' and B''') when the connection to 3G_MSC-B' has been established. MSC-B is informed via functional unit 4 that the connection has been established and that the procedure on the radio path can be initiated. The device is connected in its final position (i.e. B' to B''') when a successful procedure indication is received from functional unit 4. MSC-B is informed that all procedures in MSC-B can be terminated (illustrated by the MAP-SEND-END-SIGNAL response). The device returns to the state where B' and B'' are connected if the subsequent GSM to UMTS handover procedure fails.

***** NEXT MODIFIED SECTION *****

11.7 Protocol interworking

If the 3G_MSC-A initiates an basic inter-MSC UMTS to GSM handover procedure according to MAP and BSSMAP protocols while using a RANAP protocol towards RNS-A, 3G_MSC-A has to perform the protocol interworking between RANAP on the Iu-Interface and encapsulated BSSMAP on the E-interface.

The same holds if 3G_MSC-A accepts a subsequent inter-3G_MSC GSM to UMTS handover back to 3G_MSC-A while using a RANAP protocol towards RNS-B.

***** NEXT MODIFIED SECTION *****

12.3 Handover/Relocation control procedures in 3G_MSC-B (functional unit 3)

The procedures of functional unit 3 are given in form of SDL diagrams in figure 44. To easily distinguish the interface concerned the messages received or sent from this unit are prefixed with either 'MAP' for a MAP message, 'A' for an A-Interface message, 'Iu' for an Iu-Interface message or 'T' for an ISDN/PSTN message. The procedure in functional unit 3 include:

- i) inter 3G_MSC handover/relocation from 3G_MSC-A;

This case is initiated by 3G_MSC-A, and includes allocation and establishment of the new radio resources. The procedure is outlined in subclauses 8.1.1 and 8.1.2. for UMTS to GSM handover, subclauses 8.2.1 and 8.2.2 for GSM to UMTS handover and subclauses 8.3.1 and 8.3.2 for relocation.

- ii) intra-3G_MSC UMTS to GSM handovers within the area controlled by 3G_MSC-B;

This procedure is the same as that of ii) in subclause 11.3, except that the Iu-RELOCATION-REQUIRED is received by 3G_MSC-B. After successful completion of the intra-3G_MSC handover, 3G_MSC-B shall notify 3G_MSC-A by sending an A-HANDOVER-PERFORMED message.

- iii) intra-3G_MSC GSM to UMTS handovers within the area controlled by 3G_MSC-B;

This procedure is the same as that of ii) in subclause 11.3, except that the A-HANDOVER-REQUIRED is received by 3G_MSC-B. After successful completion of the intra-3G_MSC handover, 3G_MSC-B shall notify 3G_MSC-A by sending an A-HANDOVER-PERFORMED message.

- iv) intra-3G_MSC SRNS Relocation within the area controlled by 3G_MSC-B;

This procedure is the same as that of ii) in subclause 11.3, except that the Iu-RELOCATION-REQUIRED is received by 3G_MSC-B. After successful completion of the intra-3G_MSC SRNS relocation, if security algorithms have been changed, 3G_MSC-B shall notify 3G_MSC-A by sending an A-HANDOVER-PERFORMED or an Iu-LOCATION-REPORT message, depending on the access network protocol used encapsulated on the E-interface (see subclauses 4.4.1 and 6.2.3).

- v) subsequent handover/relocation to another 3G_MSC (3G_MSC-A or 3G_MSC-B);

The initiation procedure is essentially the same as that of i) of subclause 11.3. The Handover Command to the BSS or the Relocation Command to the RNS is now generated by 3G_MSC-B after the A-HO-REQUEST-ACKNOWLEDGE or Iu-RELOCATION-REQUEST-ACKNOWLEDGE is received from 3G_MSC-A (via functional unit 4). The procedure is terminated in 3G_MSC-B when 3G_MSC-B receives a terminate procedure indication from functional unit 4.

***** NEXT MODIFIED SECTION *****

12.7 Protocol interworking

If the 3G_MSC-B accepts an Inter-3G_MSC GSM to UMTS handover procedure according to MAP and BSSMAP protocols while using a RANAP protocol towards RNS-B, 3G_MSC-B has to perform the protocol interworking between RANAP on the Iu-Interface and encapsulated BSSMAP on the E-interface.

The same holds if 3G_MSC-B initiates a subsequent inter-MSC UMTS to GSM handover while using a RANAP protocol towards RNS-A.

If during the supervision, i.e. while the UE/MS is not in the area of MSC-A or 3G_MSC-A, the protocol used encapsulated on the E-interface and the protocol used between 3G_MSC-B and the serving BSS or RNS are different, then 3G_MSC-B has to perform the protocol interworking between BSSAP and RANAP.

NOTE: The two protocols are different, e.g., after an inter-MSC GSM to UMTS inter-system handover, or after an inter-MSC SRNS relocation to 3G_MSC-B followed by a subsequent intra-3G_MSC-B UMTS to GSM inter-system handover.

**3GPP TSG-CN1 Meeting #21
Cancun, Mexico, 26.- 30. November 2001**

**Tdoc N1-011807
(also submitted as Tdoc N4-011268)**

CR-Form-v5

CHANGE REQUEST

⌘ **23.009 CR 060** ⌘ rev **-** ⌘ Current version: **4.2.0** ⌘

For **HELP** on using this form, see bottom of this page or look at the pop-up text over the ⌘ symbols.

Proposed change affects: ⌘ (U)SIM ME/UE Radio Access Network Core Network

Title:	⌘ E-interface protocol during the supervision phase		
Source:	⌘ Siemens		
Work item code:	⌘ GSM/UMTS interworking	Date:	⌘ 16.11.01
Category:	⌘ A	Release:	⌘ REL-4
	Use <u>one</u> of the following categories: F (correction) A (corresponds to a correction in an earlier release) B (addition of feature), C (functional modification of feature) D (editorial modification) Detailed explanations of the above categories can be found in 3GPP TR 21.900 .		Use <u>one</u> of the following releases: 2 (GSM Phase 2) R96 (Release 1996) R97 (Release 1997) R98 (Release 1998) R99 (Release 1999) REL-4 (Release 4) REL-5 (Release 5)

Reason for change:	⌘	1) Currently, subclauses 7, 8.1, 8.2, and 8.3 specify general rules about the usage of BSSAP or RANAP on the E-interface during the 'supervision phase'. These rules are in contradiction to other parts of TS 23.009, as i) for subsequent inter-MSC handover the radio access protocol used encapsulated on the E-interface depends only on the serving and the target radio access system, but not on the protocol used on the E-interface during basic inter-MSC handover; ii) a subsequent intra-MSC-B intra GSM or inter-system handover is always indicated with a BSSMAP message (Handover Performed), regardless of the protocol used on the E-interface during basic inter-MSC handover. 2) Alignment of message names with the conventions used in the rest of the specification 3) Clarification of the protocol interworking scenarios specified in subclauses 11.7 and 12.7.
Summary of change:	⌘	The exceptions to the general rules specified in subclauses 7, 8.1, 8.2 and 8.3. are added to the respective paragraphs.
Consequences if not approved:	⌘	i) Certain cases of subsequent inter-MSC handover are not supported by the standard, like e.g. subsequent inter-MSC SRNS relocation after basic inter-MSC GSM to UMTS inter-system handover. ii) Inconsistent specification with regard to the usage of Handover Performed.

Clauses affected:	⌘	4.2.1, 4.3.1, 4.4.1, 6.2.2, 6.2.3, 7, 8.1, 8.2, 8.3, 10.3, 11.3, 11.7, 12.3, 12.7
Other specs affected:	⌘	<input type="checkbox"/> Other core specifications <input type="checkbox"/> Test specifications <input type="checkbox"/> O&M Specifications
Other comments:	⌘	

How to create CRs using this form:

Comprehensive information and tips about how to create CRs can be found at: http://www.3gpp.org/3G_Specs/CRs.htm. Below is a brief summary:

- 1) Fill out the above form. The symbols above marked ☒ contain pop-up help information about the field that they are closest to.
- 2) Obtain the latest version for the release of the specification to which the change is proposed. Use the MS Word "revision marks" feature (also known as "track changes") when making the changes. All 3GPP specifications can be downloaded from the 3GPP server under <ftp://ftp.3gpp.org/specs/> For the latest version, look for the directory name with the latest date e.g. 2001-03 contains the specifications resulting from the March 2001 TSG meetings.
- 3) With "track changes" disabled, paste the entire CR form (use CTRL-A to select it) into the specification just in front of the clause containing the first piece of changed text. Delete those parts of the specification which are not relevant to the change request.

4.2 MSC-B

4.2.1 Role of MSC-B

In the Intra-MSC handover case, the MSC-B keeps the control of the whole Intra-MSC handover procedure.

MSC-B notifies MSC-A or 3G_MSC-A of successful intra -MSC-B handover completion by using the A_HANDOVER_PERFORMED message.

In the Inter-MSC handover case, the role of MSC-B (MSC-B') is only to provide radio resources control within its area. This means that MSC-B keeps control of the radio resources connection and release towards BSS-B. MSC-B will do some processing on the BSSMAP information received on the E-interface or A-interface whereas it will relay the DTAP information transparently between A-interface and E-interface. MSC-A initiates and drives a subset of BSSMAP procedures towards MSC-B, while MSC-B controls them towards its BSSs to the extent that MSC-B is responsible for the connections of its BSSs. The release of the dedicated resources between MSC-B and BSS-B is under the responsibility of MSC-B and BSS-B, and is not directly controlled by MSC-A. When clearing is to be performed due to information received from BSS-B, MSC-B shall transfer this clearing indication to MSC-A, to clear its connection with BSS-B, to terminate the dialogue with MSC-A through the E-interface, and to release its circuit connection with MSC-A, if any. In the same way, the release of the connection to its BSS-B, is initiated by MSC-B, when the dialogue with MSC-A ends normally and a release is received from the circuit connection with MSC-A, if any, or when the dialogue with the MSC-A ends abnormally.

When a release is received by MSC-B for the circuit connection with MSC-A then MSC-B shall release the circuit connection.

In the Inter-system Inter-MSC handover case, the role of MSC-B (MSC-B') is only to provide radio resources control within its area. This means that MSC-B keeps control of the radio resources connection and release towards BSS-B. MSC-B will do some processing on the BSSMAP information received on the E-interface or A-interface whereas it will relay the DTAP information transparently between A-interface and E-interface. 3G_MSC-A initiates and drives a subset of BSSMAP procedures towards MSC-B, while MSC-B controls them towards its BSSs to the extent that MSC-B is responsible for the connections of its BSSs. The release of the dedicated resources between MSC-B and BSS-B is under the responsibility of MSC-B and BSS-B, and is not directly controlled by 3G_MSC-A. When clearing is to be performed due to information received from BSS-B, MSC-B shall transfer this clearing indication to 3G_MSC-A, to clear its connection with BSS-B, to terminate the dialogue with 3G_MSC-A through the E-interface, and to release its circuit connection with 3G_MSC-A, if any. In the same way, the release of the connection to its BSS-B, is initiated by MSC-B, when the dialogue with 3G_MSC-A ends normally and a release is received from the circuit connection with MSC-A, if any, or when the dialogue with the MSC-A ends abnormally.

When a release is received by MSC-B for the circuit connection with 3G_MSC-A then MSC-B shall release the circuit connection.

***** NEXT MODIFIED SECTION *****

4.3 3G_MSC-A

For roles and functional composition of the 3G_MSC-A working as pure GSM MSC, please see previous clause ("MSC-A").

4.3.1 Role of 3G_MSC-A

In the Intra-3G_MSC handover/relocation case, the 3G_MSC-A (simply termed 3G_MSC) controls the call, the mobility management and the radio resources before, during and after an Intra-3G_MSC handover/relocation. When RANAP or BSSMAP procedures have to be performed, they are initiated and driven by 3G_MSC-A.

In a network implementing the "Flexible Iu interface for handover/relocation" option, 3G_MSC-A may optionally use a global title based on the Global RNC-Id for the addressing of the Iu interface messages towards the target RNC.

In the case of intra-MSC handover of a speech call, 3G_MSC-A controls the transcoder in the core network. The 3G_MSC-A determines if a transcoder is required to be inserted or released in the CN.

In the case of Inter-3G_MSC relocation, 3G_MSC-A links out the transcoder.

In the Inter-3G_MSC relocation case, 3G_MSC-A is the 3G_MSC that controls the call and the mobility management of the UE during the call, before, during and after a basic or subsequent relocation. When RANAP procedures related to dedicated resources have to be performed towards the UE, they are initiated and driven by 3G_MSC-A. The 3G_MSC-A - 3G_MSC-B interface works as a 3G_MSC - RNS interface for the RANAP procedures. The Direct Transfer signalling is relayed transparently by 3G_MSC-B between 3G_MSC-A and the UE.

During a successful relocation the order to perform location reporting at change of Service Area is not transferred to the target RNS. In the Intra-3G_MSC-A relocation case, the 3G_MSC-A re-issues the Location Reporting Control towards the target RNS. In the Inter-3G_MSC relocation case, 3G_MSC-A keeps the control of the Location Report Control procedure. However, re-issuing the Iu-LOCATION-REPORTING-CONTROL messages due to subsequent Intra-3G_MSC-B relocations is the responsibility of 3G_MSC-B.

During a basic relocation, 3G_MSC-A initiates and controls all the relocation procedure, from its initiation (reception of Relocation Required from RNS-A on Iu-interface) until its completion (reception of Relocation Complete from 3G_MSC-B on E-interface).

During a subsequent relocation back to 3G_MSC-A, 3G_MSC-A acts as an RNS towards 3G_MSC-B, which controls the relocation procedure until the termination in 3G_MSC-A of the handover radio resources allocation (sending of the Relocation Request Acknowledge to 3G_MSC-B from 3G_MSC-A). Then all relocation related messages shall terminate at 3G_MSC-A (e.g. Relocation Detect/Complete from RNS-B, Relocation Cancel from RNS-A).

During a subsequent relocation to a third 3G_MSC, 3G_MSC-A works towards 3G_MSC-B' as described above in the basic relocation paragraph and towards 3G_MSC-B as described above in subsequent relocation paragraph.

In the Inter-System, inter-3G_MSC handover case, 3G_MSC-A is the 3G_MSC which controls the call and the mobility management of the UE/MS during the call, before, during and after a basic or subsequent inter-system handover. When BSSAP procedures related to dedicated resources have to be performed towards the UE/MS, they are initiated and driven by 3G_MSC-A. The 3G_MSC-A – MSC-B interface works as a 3G_MSC – BSS interface for a subset of BSSMAP procedures. These BSSMAP procedures described in 3GPP TS 09 08 [7] are those related to dedicated resources. The DTAP signalling is relayed transparently by MSC-B between 3G_MSC-A and the UE/MS.

During a basic inter-system UMTS to GSM handover, 3G_MSC-A initiates and controls all the handover procedure, from its initiation (reception of Relocation Required from RNS-A on Iu-interface) until its completion (reception of Handover Complete from MSC-B on E-interface).

During a subsequent inter-system UMTS to GSM handover back to 3G_MSC-A, 3G_MSC-A acts as a BSS towards 3G_MSC-B, which controls the handover procedure until the termination in 3G_MSC-A of the handover radio resources allocation (sending of the Handover Request Acknowledge to 3G_MSC-B from 3G_MSC-A). Then all handover related messages shall terminate at 3G_MSC-A (e.g. Handover Detect/Complete from BSS-B, Relocation Cancel from RNS-A).

During a subsequent inter-system UMTS to GSM handover to a third 3G_MSC, 3G_MSC-A works towards MSC-B' as described above in the basic inter-system handover paragraph and towards 3G_MSC-B as described above in subsequent inter-system handover paragraph.

During a basic inter-system GSM to UMTS handover, 3G_MSC-A initiates and controls all the handover procedure, from its initiation (reception of Handover Required from BSS-A on A-interface) until its completion (reception of Handover Complete from 3G_MSC-B on E-interface).

During a subsequent inter-system GSM to UMTS handover back to 3G_MSC-A, 3G_MSC-A acts as an RNS towards MSC-B, which controls the handover procedure until the termination in 3G_MSC-A of the handover radio resources allocation (sending of the Handover Request Acknowledge to MSC-B from 3G_MSC-A). Then all handover related messages shall terminate at 3G_MSC-A (e.g. Relocation Detect/Complete from RNS-B, Handover Failure from BSS-A).

During a subsequent inter-system GSM to UMTS handover to a third 3G_MSC, 3G_MSC-A works towards 3G_MSC-B' as described above in the basic inter-system handover paragraph and towards MSC-B as described above in subsequent inter-system handover paragraph.

If 3G_MSC-A supports the optional supplementary service Multicall (See 3GPP TS 23.135) and UE is engaged with multiple bearers the following description applies:

- In the Intra-3G_MSC relocation case, the 3G-MSC-A tries to relocate all bearers to a new RNS.
- In the basic relocation case, the 3G-MSC-A tries to relocate all bearers to 3G_MSC-B. If 3G_MSC-A receives an indication that the 3G_MSC-B does not support multiple bearers, then 3G_MSC-A shall be able to select one bearer to be handed over according to the priority level defined as RAB parameters in 3GPP TS 25.413 and tries again to relocate the selected bearer.
- In the subsequent relocation to a third 3G_MSC-B' case, the 3G-MSC-A tries to relocate all bearers to 3G_MSC-B'. If 3G_MSC-A receives an indication that the 3G_MSC-B' does not support multiple bearers, then 3G_MSC-A shall be able to select one bearer to be handed over according to the priority level defined as RAB parameters in 3GPP TS 25.413 [11] and tries again to relocate the selected bearer.
- In the Intra-3G_MSC inter-system UMTS to GSM handover case and the basic inter-system UMTS to GSM handover case, the 3G_MSC-A shall be able to select one bearer to be handed over according to the priority level defined as RAB parameters in 3GPP TS 25.413 [11] and tries to handover the selected bearer.
- In all cases described above, 3G_MSC-A shall release some calls which has been carried by the bearers failed to set up in new RNS or the bearers not to be handed over.

***** NEXT MODIFIED SECTION *****

4.4 3G_MSC-B

For roles and functional composition of the 3G_MSC-B working as pure GSM MSC, please see previous clause ("MSC-B").

4.4.1 Role of 3G_MSC-B

In the Intra-3G_MSC handover/relocation case, the 3G_MSC-B keeps the control of the whole Intra-3G_MSC handover/relocation procedure. 3G_MSC-B notifies MSC-A or 3G_MSC-A of intra-3G_MSC-B InterSystem handover and intra GSM handovers, by using the A_HANDOVER_PERFORMED message.

In case of intra-3G_MSC-B SRNS_relocation, if security algorithms have been changed:

- a) When encapsulated BSSAP is used on the E interface, the A_HANDOVER_PERFORMED message shall be sent.
- b) When encapsulated RANAP is used on the E interface, the Iu_LOCATION_REPORT message shall be sent.

On reception of an order to perform location reporting at change of Service Area from 3G_MSC-A, 3G_MSC-B shall be responsible to re-issue the Iu-LOCATION-REPORTING-CONTROL ~~Location Reporting Control~~ message after subsequent Intra-3G_MSC-B relocations/handovers. This shall be performed immediately after the successful completion of the Relocation Resource Allocation procedure.

In both cases, the selected UMTS algorithm(s) shall be indicated in the MAP_PROCESS_ACCESS_SIGNALLING_REQUEST request.

In a network implementing the "Flexible Iu interface for handover/relocation" option, in the Intra-3G_MSC handover/relocation case, 3G_MSC-B may optionally use a global title based on the Global RNC-Id for the addressing of the Iu interface messages towards the target RNC.

The role of 3G_MSC-B is also to provide transcoder resources.

In the Inter-3G_MSC relocation case, the role of 3G_MSC-B (3G_MSC-B') is only to provide radio resources control within its area. This means that 3G_MSC-B keeps control of the radio resources connection and release towards RNS-B. 3G_MSC-B will do some processing on the RANAP information received on the E-interface or the RANAP information received on the Iu-interface whereas it will relay the Direct Transfer information transparently between Iu-interface and E-interface. 3G_MSC-A initiates and drives RANAP procedures towards 3G_MSC-B, while 3G_MSC-B controls them towards its RNSs to the extent that 3G_MSC-B is responsible for the connections of its RNSs. The release of the dedicated resources between 3G_MSC-B and RNS-B is under the responsibility of 3G_MSC-B and RNS-B, and is not directly controlled by 3G_MSC-A. When clearing is to be performed due to information received from RNS-B, 3G_MSC-B shall transfer this clearing indication to 3G_MSC-A, to clear its connection with RNS-B, to terminate the dialogue with 3G_MSC-A through the E-interface, and to release its circuit connection with 3G_MSC-A, if any. In the same way, the release of the connection to its RNS-B, is initiated by 3G_MSC-B, when the dialogue with 3G_MSC-A ends normally and a release is received from the circuit connection with 3G_MSC-A, if any, or when the dialogue with the 3G_MSC-A ends abnormally.

When a release is received by 3G_MSC-B for the circuit connection with 3G_MSC-A then 3G_MSC-B shall release the circuit connection.

In the Inter-system UMTS to GSM Inter-3G_MSC handover case, the role of 3G_MSC-B (3G_MSC-B') is only to provide radio resources control within its area. This means that 3G_MSC-B keeps control of the radio resources connection and release towards BSS-B. 3G_MSC-B will do some processing on the BSSMAP information received on the E-interface or the BSSMAP information received on the A-interface whereas it will relay the DTAP information transparently between A-interface and E-interface. 3G_MSC-A initiates and drives a subset of BSSMAP procedures towards 3G_MSC-B, while 3G_MSC-B controls them towards its BSSs to the extent that 3G_MSC-B is responsible for the connections of its BSSs. The release of the dedicated resources between 3G_MSC-B and BSS-B is under the responsibility of 3G_MSC-B and BSS-B, and is not directly controlled by 3G_MSC-A. When clearing is to be performed due to information received from BSS-B, 3G_MSC-B shall transfer this clearing indication to 3G_MSC-A, to clear its connection with BSS-B, to terminate the dialogue with 3G_MSC-A through the E-interface, and to release its circuit connection with MSC-A, if any. In the same way, the release of the connection to its BSS-B, is initiated by 3G_MSC-B, when the dialogue with 3G_MSC-A ends normally and a release is received from the circuit connection with 3G_MSC-A, if any, or when the dialogue with the MSC-A ends abnormally.

When a release is received by 3G_MSC-B for the circuit connection with 3G_MSC-A then 3G_MSC-B shall release the circuit connection.

In the Inter-system GSM to UMTS Inter-3G_MSC handover case, the role of 3G_MSC-B (3G_MSC-B') is only to provide radio resources control within its area. This means that 3G_MSC-B keeps control of the radio resources connection and release towards RNS-B. 3G_MSC-B will do some processing on the BSSMAP information received on the E-interface or the RANAP information received on the Iu-interface whereas it will relay the Direct Transfer information transparently between Iu-interface and E-interface. MSC-A initiates and drives a subset of BSSMAP procedures towards 3G_MSC-B, while 3G_MSC-B controls them towards its RNSs to the extent that 3G_MSC-B is responsible for the connections of its RNSs. The release of the dedicated resources between 3G_MSC-B and RNS-B is under the responsibility of 3G_MSC-B and RNS-B, and is not directly controlled by MSC-A. When clearing is to be performed due to information received from RNS-B, 3G_MSC-B shall transfer this clearing indication to MSC-A, to clear its connection with RNS-B, to terminate the dialogue with MSC-A through the E-interface, and to release its circuit connection with MSC-A, if any. In the same way, the release of the connection to its RNS-B, is initiated by 3G_MSC-B, when the dialogue with MSC-A ends normally and a release is received from the circuit connection with MSC-A, if any, or when the dialogue with the MSC-A ends abnormally.

When a release is received by 3G_MSC-B for the circuit connection with MSC-A then 3G_MSC-B shall release the circuit connection.

If 3G_MSC-B does not support the optional supplementary service Mutlicall (see 3GPP TS 23.135) and 3G_MSC-A requests to relocate multiple bearers, 3G_MSC-B shall indicate that it does not support multiple bearers to 3G_MSC-A.

If 3G_MSC-B supports the optional supplementary service Multicall (see 3GPP TS 23.135) and UE is engaged with multiple bearers the following description applies:

- In the basic relocation case, the 3G_MSC-B shall be able to allocate an Handover Number for each bearer. The 3G-MSC-B shall also be able to select some bearers so that the number of bearers will fulfill the maximum number of bearers supported by the 3G_MSC-B.
- In the Intra-3G_MSC relocation case, the 3G-MSC-B tries to relocate all bearers to a new RNS.

- In the subsequent relocation back to the 3G_MSC-A or to a third 3G_MSC-B' case, the 3G-MSC-B tries to request to the 3G_MSC-A to relocate all bearers to the 3G_MSC-A or to the 3G_MSC-B'.
- In the Intra-3G_MSC inter-system UMTS to GSM handover case and the subsequent inter-system UMTS to GSM handover back to the 3G_MSC-A or to a third MSC-B' case, the 3G_MSC-B shall be able to select one bearer to be handed over according to the priority level defined as RAB parameters in 3GPP TS 25.413 [11] and tries to handover the selected bearer.

***** NEXT MODIFIED SECTION *****

6.2.2 Intra-3G_MSC GSM to UMTS Handover

The procedure for a successful Intra-3G_MSC handover is shown in figure 9. It is assumed that selection of a candidate UE/MS has already taken place within the BSC based upon the criteria presented in clause 5. The exact algorithm, in the BSC, for determining a candidate UE/MS is not addressed in the present document. The procedures discussed do not make use of the Mobile Application Part (MAP), represented by signalling function 4 in figures 4 and 6. The procedure described in this clause covers case ii).

In case of subsequent handover the following applies. If 3G_MSC-B supports location reporting at change of Service Area and if encapsulated BSSAP signalling is used on the E-interface, 3G_MSC-B shall always initiate the Location Reporting Control procedure at change of Service Area towards the target RNS since no request for Location Reporting can be received from MSC-A. In that case, the Location Reporting Control procedure shall be initiated by 3G_MSC-B after the Relocation Resource Allocation procedure has been executed successfully.

The change of Service Area shall be reported to MSC-A within an A--HANDOVER--PERFORMED message.

In the case of ongoing voice group calls, the handover does not take place since voice group calls are not supported in UMTS.

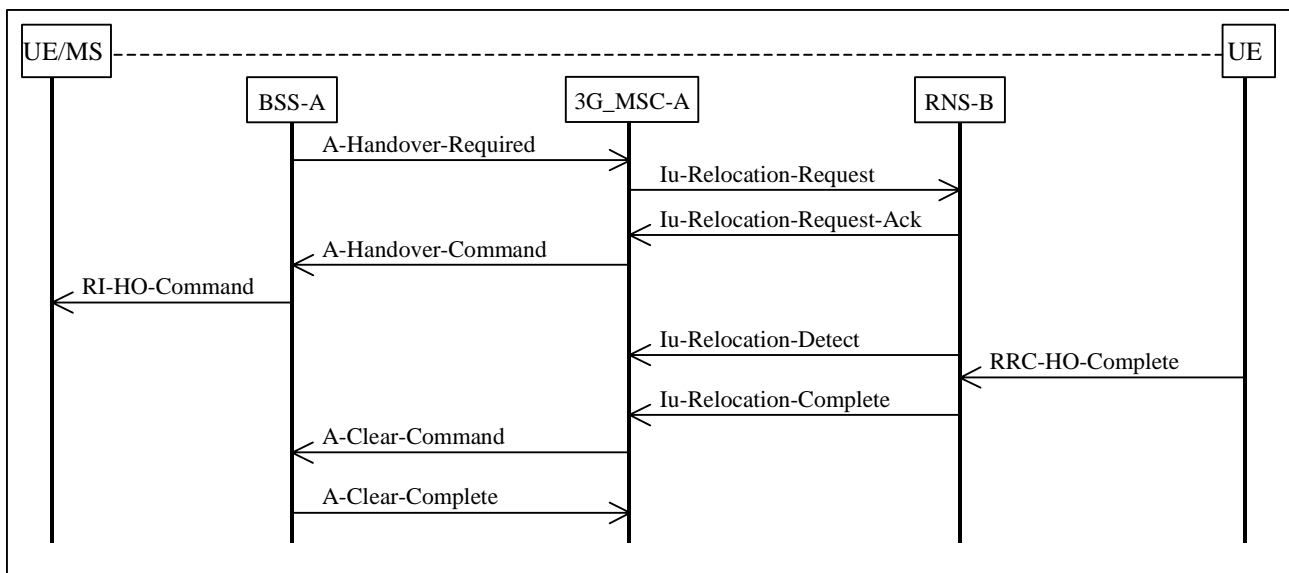

Figure 9: Basic External Intra-3G_MSC GSM to UMTS Handover Procedure

The successful operation of the procedure is as follows. When the BSS (BSS-A), currently supporting the UE, determines that the UE requires to be handed over to UMTS it will send an A-HANDOVER-REQUIRED message to the 3G_MSC (3G_MSC-A). The A-HANDOVER-REQUIRED message shall contain a single cell, to which the UE can be handed over. When the 3G_MSC-A receives the A-HANDOVER-REQUIRED message it shall begin the process of handing over the UE to a new RNS (RNS-B). The 3G_MSC-A shall generate an Iu-RELOCATION-REQUEST message to the selected RNS (RNS-B). When RNS-B receives the Iu-RELOCATION-REQUEST message it shall take the necessary action to allow the UE to access the radio resource of RNS-B, this is detailed in the 3GPP TS 25.300

series and the 3GPP TS 25.200 series of Technical Specifications. The switching of the radio resource through the necessary terrestrial resources is detailed in the 3GPP TS 25.430 series and 3GPP TS 25.413 [11].

Once resource allocation has been completed by RNS-B, it shall return an Iu-RELOCATION-REQUEST-ACK. to 3G_MSC-A. When this message is received by 3G_MSC-A it shall begin the process of instructing the UE to tune to a new dedicated radio resource. An A-HANDOVER-COMMAND will be sent by the 3G_MSC-A to BSS-A. On receipt of the A-HANDOVER-COMMAND message BSS-A will send the radio interface message RI-HANDOVER-COMMAND. The UE will then access the new radio resource. On detection of the UE, the RNS-B shall send an Iu-RELOCATION-DETECT to 3G_MSC-A. When the UE is successfully communicating with the RNS-B an RRC-HANDOVER-COMplete message will be sent by the UE to RNS-B. The RNS-B will then send an Iu-RELOCATION-COMplete message to 3G_MSC-A.

NOTE: The Iu-RELOCATION-REQUEST-ACK from RNS-B contains the complete RRC message that shall be sent by BSS-A to the MS in the RI-HANDOVER-COMMAND, 3G_MSC-A transparently passes this radio interface message onto BSS-A.

After 3G_MSC-A has received the Iu-RELOCATION-COMplete message from RNS-B, it shall begin to release the resources allocated on BSS-A. In figure 9 the resource is released by using the A-CLEAR-COMMAND sequence.

If a failure occurs during the handover attempt, for example, A-HANDOVER-FAILURE returned from BSS-A or Iu-RELOCATION FAILURE returned from RNS-B, then 3G_MSC-A will terminate the handover to RNS-B. Under these conditions 3G_MSC-A may optionally take one of a number of actions:

- i) await the next A-HANDOVER-REQUIRED message;
- ii) send an A-HANDOVER-REQUIRED-REJECT to BSS-A, if an A-HANDOVER-COMMAND has not already been sent.

The exact action taken is dependent on whether the failure occurs before or after the A-HANDOVER-COMMAND has been sent.

In all cases the existing connection to the UE shall not be cleared.

During the period that the UE is not in communication with the network 3G_MSC-A shall queue all appropriate messages. All messages shall be delivered to the UE once communication is resumed. In the case of an Intra-3G_MSC GSM to UMTS handover on 3G_MSC-B then the messages shall be queued by 3G_MSC-B.

6.2.3 Procedure for Intra-3G_MSC SRNS Relocation

The procedure for a successful Intra-3G_MSC SRNS Relocation is shown in figures 10 and 11. SRNS Relocation is used to relocate the serving RNS functionality from one RNS to another. The procedure may or may not involve change of the radio resources assigned for the corresponding UE. Whether or not the Relocation includes change of radio resources assigned for the UE does not affect the SRNS Relocation procedure in the Core Network.

In case of subsequent Intra-3G_MSC-B SRNS relocation the following applies:

- If 3G_MSC-B has previously received an order to perform location reporting at change of Service Area from 3G_MSC-A and if 3G_MSC-B also supports Location Reporting Control, it shall issue the Iu-LOCATION-REPORTING-CONTROL message towards the target RNS immediately after successful completion of relocation. Upon receipt of Iu-LOCATION-REPORT, 3G_MSC-B shall forward it towards 3G_MSC-A via E interface.

If 3G_MSC-B supports location reporting at change of Service Area and if encapsulated BSSAP signalling is used on the E-interface, 3G_MSC-B shall always initiate the Location Reporting Control procedure at change of Service Area towards the target RNS, since no request for Location Reporting can be received from MSC-A. In that case the Location Reporting Control procedure shall be initiated by 3G_MSC-B after the Relocation Resource Allocation procedure has been executed successfully. The change of Service Area shall be reported to MSC-A within an A-HANDOVER-PERFORMED message.

It is assumed that selection of a candidate UE has already taken place within RNS based upon the criteria presenting in clause 5. The exact algorithm, in RNS, for determining a candidate UE is not addressed in the present document. The procedure discussed does not make use of the Mobile Application Part (MAP), represented by signalling function 4 in figures 4 and 6. The procedure described in this clause covers case ii).

***** NEXT MODIFIED SECTION *****

7 General description of the procedures for inter - MSC handovers

The following clauses describe two options for the Basic and Subsequent Handover procedures. The first, as described in clauses 7.1 and 7.3 respectively, provides for a circuit connection between MSC-A and MSC-B. The second, as described in clauses 7.2 and 7.4 respectively, provides for a Basic and Subsequent Handover without the provision of a circuit connection between MSC-A and MSC-B.

In all the above mentioned clauses, the following principles apply:

- during the handover resource allocation, only the handover related messages that are part of the applicable BSSAP subset - as defined in 3GPP TS 09.08 [7] - shall be transferred on the E-interface;
- the trace related messages that are part of the applicable BSSAP subset - as defined in 3GPP TS 09.08 [7] - can be sent by the MSC-A on the E-interface after successful handover resource allocation. In the clauses 7.1 and 7.2, it is however allowed at basic handover initiation on the E-Interface to transfer one trace related message that is part of the applicable BSSAP subset - as defined in 3GPP TS 09.08 [7] - together with the applicable handover related message. The applicable handover related message shall always appear as the first message;
- during the handover execution, ie while the MS is not in communication with the network, the MSC-A shall queue all outgoing BSSAP messages until the communication with the MS is resumed;
- finally, during supervision, ie while the MS is not in the area of MSC-A after a successful Inter-MSC handover, the subset of BSSAP procedures and their related messages - as defined in 3GPP TS 09.08 [7] - shall apply on the E-Interface; As the only exception to this rule, in case of a subsequent inter-MSC SRNS relocation back to 3G MSC-A or to a third 3G MSC-B' the Relocation Resource Allocation procedure as specified in 3GPP TS 29.108 [15] shall apply (see subclause 8.3, first list item).

NOTE: A subsequent inter-MSC SRNS relocation back to 3G MSC-A or to a third 3G MSC-B' can occur, e.g., if after the basic inter-MSC handover to 3G MSC-B the MS performed a subsequent intra-3G MSC-B GSM to UMTS inter-system handover;

- during the intra-MSC-B handover execution, if any, the MSC-B shall queue all outgoing BSSAP messages until the communication with the MS is resumed.

***** NEXT MODIFIED SECTION *****

8 General Description of the procedures for inter - 3G_MSC handovers

8.1 Handover UMTS to GSM

The following clauses describe two options for the Basic and Subsequent UMTS to GSM Handover procedures. The first, as described in clauses 8.1.1 and 8.1.3 respectively, provides for a circuit connection between 3G_MSC-A and 3G_MSC-B. The second, as described in clauses 8.1.2 and 8.1.4 respectively, provides for a Basic and Subsequent Handover without the provision of a circuit connection between 3G_MSC-A and 3G_MSC-B. 3G_MSC can also be a pure GSM MSC.

In all the above mentioned clauses, the following principles apply:

- during the handover resource allocation, only the handover related messages that are part of the applicable BSSAP subset - as defined in 3GPP TS 09.08 [7] - shall be transferred on the E-interface;
- the trace related messages that are part of the applicable BSSAP subset - as defined in 3GPP TS 09.08- can be sent by the 3G_MSC-A on the E-interface after successful handover resource allocation. In the clauses 8.1.1 and 8.1.2, it is however allowed at basic handover initiation on the E-Interface to transfer one trace related message that is part of the applicable BSSAP subset - as defined in 3GPP TS 09.08 [7] - together with the applicable handover related message. The applicable handover related message shall always appear as the first message;
- during the handover execution, i.e. while the UE/MS is not in communication with the network, the 3G_MSC-A shall queue all outgoing BSSAP/Direct Transfer messages until the communication with the UE/MS is resumed;
- finally, during supervision, i.e. while the UE/MS is not in the area of 3G_MSC-A after a successful Inter-3G_MSC handover, the subset of BSSAP procedures and their related messages - as defined in 3GPP TS 09.08 [7] - shall apply on the E-Interface;. As the only exception to this rule, in case of a subsequent inter-MSC SRNS relocation back to 3G_MSC-A or to a third 3G_MSC-B' the Relocation Resource Allocation procedure as specified in 3GPP TS 29.108 [15] shall apply (see subclause 8.3, first list item).

NOTE: A subsequent inter-MSC SRNS relocation back to 3G_MSC-A or to a third 3G_MSC-B' can occur, e.g., if after the basic inter-MSC handover to 3G_MSC-B the MS performed a subsequent intra-3G_MSC-B GSM to UMTS inter-system handover;

- during the intra-3G_MSC -B handover execution, if any, the 3G_MSC -B shall queue all outgoing BSSAP messages until the communication with the UE/MS is resumed.

***** NEXT MODIFIED SECTION *****

8.2 Handover GSM to UMTS

The following clauses describe two options for the Basic and Subsequent GSM to UMTS Handover procedures. The first, as described in clauses 8.2.1 and 8.2.3 respectively, provides for a circuit connection between (3G_)MSC-A and (3G_)MSC-B. The second, as described in clauses 8.2.2 and 8.2.4 respectively, provides for a Basic and Subsequent Handover without the provision of a circuit connection between (3G_)MSC-A and (3G_)MSC-B. In all the above mentioned clauses, the following principles apply:

- during the handover resource allocation, only the handover related messages that are part of the applicable BSSAP subset - as defined in 3GPP TS 09.08 [7] - shall be transferred on the E-interface;

- the trace related messages that are part of the applicable BSSAP subset - as defined in 3GPP TS 09.08 [7] - can be sent by the MSC-A on the E-interface after successful handover resource allocation. In the clauses 8.2.1 and 8.2.2, it is however allowed at basic handover initiation on the E-Interface to transfer one trace related message that is part of the applicable BSSAP subset - as defined in 3GPP TS 09.08 [7] - together with the applicable handover related message. The applicable handover related message shall always appear as the first message;
- If 3G_MSC-B or 3G-MSC-B' supports location reporting at change of Service Area, 3G_MSC-B or 3G_MSC-B' shall always initiate the Location Reporting Control procedure at change of Service Area towards the target RNS since no request for Location Reporting can be received from MSC-A. In that case, the Location Reporting Control procedure shall be initiated by 3G_MSC-B or 3G-MSC-B' after the Relocation Resource Allocation procedure has been executed successfully. The change of Service Area shall be reported to MSC-A within an A--HANDOVER--PERFORMED message.
- during the handover execution, i.e. while the UE/MS is not in communication with the network, the MSC-A shall queue all outgoing BSSAP messages until the communication with the UE/MS is resumed;
- finally, during supervision, i.e. while the UE/MS is not in the area of MSC-A after a successful Inter-3G_MSC GSM to UMTS handover, the subset of BSSAP procedures and their related messages - as defined in 3GPP TS 09.08 [7] - shall apply on the E-Interface; As the only exception to this rule, in case of a subsequent inter-MSC SRNS relocation back to 3G_MSC-A or to a third 3G_MSC-B' the Relocation Resource Allocation procedure as specified in 3GPP TS 29.108 [15] shall apply (see subclause 8.3, first list item);
- during the intra-3G_MSC-B GSM to UMTS handover execution, if any, the 3G_MSC-B shall queue all outgoing Direct Transfer messages until the communication with the UE/MS is resumed.

***** NEXT MODIFIED SECTION *****

8.3 SRNS Relocation

The following clauses describe two options for the Basic and Subsequent Relocation procedures. The first, as described in clauses 8.3.1 and 8.3.3 respectively, provides for a circuit connection between 3G_MSC-A and 3G_MSC-B. The second, as described in clauses 8.3.2 and 8.3.4 respectively, provides for a Basic and Subsequent Relocation without the provision of a circuit connection between 3G_MSC-A and 3G_MSC-B.

In all the above mentioned clauses, the following principles apply:

- during the relocation resource allocation, only the handover related messages that are part of the applicable RANAP subset - as defined in 3GPP TS 29.108 [15] - shall be transferred on the E-interface;
- the trace related messages that are part of the applicable RANAP subset - as defined in 3GPP TS 29.108 [15] - can be sent by the 3G_MSC-A on the E-interface after successful relocation resource allocation. In the clauses 8.3.1 and 8.3.2, it is however allowed at basic relocation initiation on the E-Interface to transfer one trace related message that is part of the applicable RANAP subset - as defined in 3GPP TS 29.108 [15] - together with the applicable relocation related message. The applicable relocation related message shall always appear as the first message;
- during the relocation execution, i.e. while the UE is not in communication with the network, the 3G_MSC-A shall queue all outgoing RANAP messages until the communication with the UE is resumed;
- finally, during supervision, i.e. while the UE is not in the area of 3G_MSC-A after a successful Inter-3G_MSC relocation, the subset of RANAP procedures and their related messages - as defined in 3GPP TS 29.108 [15] - shall apply on the E-Interface; As an exception to this rule, 3G_MSC-B shall notify 3G_MSC-A of a successfully completed subsequent intra-MSC-B intra GSM or inter-system handover by using the Internal Handover Indication procedure as specified in 3GPP TS 09.08 [7]. Furthermore, in case of a subsequent inter-MSC intra GSM or inter-system handover back to 3G_MSC-A or to a third 3G_MSC-B' the Handover Resource Allocation procedure as specified in 3GPP TS TS 09.08 [7] shall apply (see first list item in clause 7, subclause 8.1, and 8.2, respectively).

NOTE: A subsequent inter-MSC intra GSM or GSM to UMTS inter-system handover back to 3G_MSC-A or to a third 3G_MSC-B' can occur, e.g., if after the basic inter-MSC SRNS relocation to 3G_MSC-B the MS performed a subsequent intra-3G_MSC-B UMTS to GSM inter-system handover;

- during the intra-3G_MSC-B relocation execution, if any, the 3G_MSC-B shall queue all outgoing RANAP messages until the communication with the UE is resumed.
- after successful completion of the Intra-3G_MSC-B relocation, if 3G_MSC-B or 3G-MSC-B' has previously received an order to perform location reporting at change of Service Area from 3G_MSC-A, it shall act as specified in subclause 6.2.3.

***** NEXT MODIFIED SECTION *****

10.3 Handover control procedures MSC-B (functional unit 3)

The procedures of functional unit 3 are given in form of SDL diagrams in figure 42. To easily distinguish the interface concerned the messages received or sent from this unit are prefixed with either 'MAP' for a MAP message, 'A' for an A-Interface message or 'I' for an ISDN/PSTN message. The procedure in functional unit 3 include:

- i) handover from MSC-A.

This case is initiated by MSC-A, and includes allocation and establishment of the new radio channel. The procedure is outlined in clauses 7.1. and 7.2.

- ii) intra-MSC handovers within the area controlled by MSC-B.

This procedure is the same as that of i) in clause 9.3, except that the A-HANDOVER-REQUIRED is received by MSC-B. After successful completion of the intra-MSC handover, MSC-B shall notify MSC-A by sending an A-HANDOVER-PERFORMED message.

- iii) subsequent handover to another MSC (MSC-A or MSC-B').

The initiation procedure is essentially the same as that of i) of clause 9.3. The Handover Command to the MS is now generated by MSC-B after the A-HO-REQUEST-ACKNOWLEDGE is received from MSC-A (via functional unit 4). The procedure is terminated in MSC-B when MSC-B receives a terminate procedure indication from functional unit 4.

Timers in MSC-B.

The following procedures are supervised by timers in order to avoid a deadlock when responses are not received or the procedures fail.

The following timers are defined:

- T201: this timer supervises the queuing time for a free channel. T201 is set by O&M;
- T202: this timer supervises the time for handover completion for handover between BSSs in MSC-B. If T202 expires, the radio path and the connection on interface B' are released. T202 is set by O&M;
- T204: this timer supervises the time between sending of address complete message to MSC-A and receiving the A-HANDOVER-COMPLETE from BSS-B on MSC-B. This timer also supervises the time between issuing the handover command to the MS and receiving the MAP-SEND-END-SIGNAL response from MSC-A, for a subsequent handover. In the case of a handover without circuit connection between MSC-A and MSC-B this timer supervises the time between issuing the A-HO-REQUEST-ACKNOWLEDGE to the MSC-A and receiving the A-HANDOVER-COMPLETE from BSS-B on MSC-B. If the timer expires, then any new radio channel is released. T204 is set by O&M;
- T210: this timer is used to supervise the time for establishing a circuit connection from MSC-A to MSC-B. When T210 expires, the allocated channel in MSC-B is released. T210 is set by O&M. This timer is not started when MSC-A explicitly indicates that no handover number is needed;

- T211: this timer is used to control the time between requesting a subsequent handover (A-HO-REQUEST to the MSC-A) and receiving the response from MSC-A (A-REQUEST-ACKNOWLEDGE/A-HO-FAILURE). If T211 expires, the existing connection with the MS is maintained. T211 is set by O&M.

***** NEXT MODIFIED SECTION *****

11.3 Handover/Relocation control procedures 3G_MSC-A (functional unit 3)

The procedures of functional unit 3 are given in terms of SDL diagrams in figure 43. To easily distinguish the interface concerned the messages received or sent from this unit are prefixed with either 'MAP' for a MAP message, 'A' for an A-Interface message, 'I' for an ISDN/PSTN message or 'Iu' for an Iu-message.

The procedures of functional unit 3 include:

- i) initiation. The initiation condition is shown by the signal Iu-RELOCATION-REQUIRED or A-HANDOVER-REQUIRED;

The diagram also includes queuing when there is no channel available. Calls for which handover/relocation has been initiated should be queued with priority higher than normal calls. They should have lower priority than emergency calls.

- ii) handover/relocation of calls within the area controlled by 3G_MSC-A, i.e. handover/relocation case i);

In the handover/relocation from RNS-A/BSS-A to RNS-B/BSS-B 3G_MSC-A controls the procedures on both the previous and the new radio channel, using signals Iu-RELOCATION-REQUEST/A-HANDOVER-REQUEST and Iu-RELOCATION-COMMAND/A-HANDOVER-COMMAND. The handover/relocation procedure is completed when Iu-RELOCATION-COMplete/A-HANDOVER-COMplete is received. If this signal is not received, the radio path and the connection on interface B' are either released or the original connection is maintained.

For handover/relocation devices with three-party capabilities the device is first set up so that all interfaces Iu'A', Iu'A'' and B' are connected (illustrated by the signal 'set up handover device'). This is done when the Relocation Command is sent to serving RNS or Handover Command is sent to the serving BSS. The device is connected in its final position (i.e. Iu'A'' to B' for case ii)) (illustrated by the signal 'connect handover device') when Iu-RELOCATION-COMplete/A-HANDOVER-COMplete is received.

- iii) relocation to 3G_MSC-B. This procedure is the one described in clauses 8.3.1 and 8.3.2. For handover/relocation devices with three-party capabilities the device is set-up when 3G_MSC-A sends the Relocation Command to the UE, i.e. the interfaces Iu', B' and B'' are then connected. The device is connected in its final position (i.e. B' to B'') when the successful procedure indication is received from functional unit 4;
- iv) UMTS to GSM handover to MSC-B. This procedure is the one described in clauses 8.1.1 and 8.1.2. For handover/relocation devices with three-party capabilities the device is set-up when 3G_MSC-A sends the Relocation Command to the serving RNS, i.e. the interfaces Iu', B' and B'' are then connected. The device is connected in its final position (i.e. B' to B'') when the successful procedure indication is received from functional unit 4;
- v) GSM to UMTS handover to 3G_MSC-B. This procedure is the one described in clauses 8.2.1 and 8.2.2. For handover/relocation devices with three-party capabilities the device is set-up when MSC-A sends the Handover Command to the serving BSS, i.e. the interfaces A', B' and B'' are then connected. The device is connected in its final position (i.e. B' to B'') when the successful procedure indication is received from functional unit 4;
- vi) subsequent relocation from 3G_MSC-B to 3G_MSC-A. The procedure is described in clauses 8.3.3.1 and 8.3.4.1. When a relocation to 3G_MSC-A indication is received from functional unit 4, the handover/relocation device is set up so that interfaces B', B'' and Iu' are connected (for devices with three-party capabilities). When Iu-RELOCATION-COMplete is received, the device is connected in its final position (i.e. B' to Iu');

If Iu-RELOCATION-COMPLETE is not received (expiry of timer T704), the handover/relocation device releases interface Iu' and returns to a position where B' and B'' are connected.

vii) subsequent GSM to UMTS handover from MSC-B to 3G_MSC-A. The procedure is described in clauses 8.2.3.1 and 8.2.4.1. When a handover to 3G_MSC-A indication is received from functional unit 4, the handover device is set up so that interfaces B', B'' and A' are connected (for handover devices with three-party capabilities). When IuA-RELOCATION-COMPLETE is received, the device is connected in its final position (i.e. B' to Iu');

If IuA-RELOCATION-COMPLETE is not received (expiry of timer T504), the device releases interface Iu' and returns to a position where B' and B'' are connected.

viii) subsequent UMTS to GSM handover from 3G_MSC-B to MSC-A. The procedure is described in clauses 8.1.3.1 and 8.1.4.1. When a handover to MSC-A indication is received from functional unit 4, the handover device is set up so that interfaces B', B'' and Iu' are connected (for handover devices with three-party capabilities). When A-HANDOVER-COMPLETE is received, the device is connected in its final position (i.e. B' to A');

If A-HANDOVER-COMPLETE is not received (expiry of timer T304), the device releases interface A' and returns to a position where B' and B'' are connected.

ix) subsequent relocation from 3G_MSC-B to a third 3G_MSC (3G_MSC-B'). The procedure is described in clauses 8.3.4.2 and 8.3.5.2. The handover/relocation device is set up in its initial position, (i.e. interconnection of interfaces B', B'' and B''') when the connection to 3G_MSC-B' has been established. 3G_MSC-B is informed via functional unit 4 that the connection has been established and that the procedure on the radio path can be initiated. The device is connected in its final position (i.e. B' to B''') when a successful procedure indication is received from functional unit 4. 3G_MSC-B is informed that all procedures in 3G_MSC-B can be terminated (illustrated by the MAP-SEND-END-SIGNAL response). The device returns to the state where B' and B'' are connected if the subsequent relocation procedure fails;

x) subsequent UMTS to GSM handover from 3G_MSC-B to a third MSC (MSC-B'). The procedure is described in clauses 8.1.3.2 and 8.1.4.2. The handover/relocation device is set up in its initial position, (i.e. interconnection of interfaces B', B'' and B''') when the connection to MSC-B' has been established. 3G_MSC-B is informed via functional unit 4 that the connection has been established and that the procedure on the radio path can be initiated. The device is connected in its final position (i.e. B' to B''') when a successful procedure indication is received from functional unit 4. 3G_MSC-B is informed that all procedures in 3G_MSC-B can be terminated (illustrated by the MAP-SEND-END-SIGNAL response). The device returns to the state where B' and B'' are connected if the subsequent UMTS to GSM handover procedure fails;

xi) subsequent GSM to UMTS handover from MSC-B to a third MSC (3G_MSC-B'). The procedure is described in clauses 8.2.3.2 and 8.2.4.2. The handover/relocation device is set up in its initial position, (i.e. interconnection of interfaces B', B'' and B''') when the connection to 3G_MSC-B' has been established. MSC-B is informed via functional unit 4 that the connection has been established and that the procedure on the radio path can be initiated. The device is connected in its final position (i.e. B' to B''') when a successful procedure indication is received from functional unit 4. MSC-B is informed that all procedures in MSC-B can be terminated (illustrated by the MAP-SEND-END-SIGNAL response). The device returns to the state where B' and B'' are connected if the subsequent GSM to UMTS handover procedure fails.

NOTE: The procedures ii), vi) and vii) may be applied also in case of a handover/relocation to an RNC which is controlled by 3G_MSC-A by using the "Flexible Iu interface for handover/relocation" option.

***** NEXT MODIFIED SECTION *****

11.7 Protocol interworking

If the 3G_MSC-A initiates an basic Inter-MSC UMTS to GSM handover procedure according to MAP and BSSMAP protocols while using a RANAP protocol towards RNS-A, 3G_MSC-A has to perform the protocol interworking between RANAP on the Iu-Interface and encapsulated BSSMAP on the E-interface.

The same holds if 3G_MSC-A accepts a subsequent inter-3G_MSC GSM to UMTS handover back to 3G_MSC-A while using a RANAP protocol towards RNS-B.

***** NEXT MODIFIED SECTION *****

12.3 Handover/Relocation control procedures in 3G_MSC-B (functional unit 3)

The procedures of functional unit 3 are given in form of SDL diagrams in figure 44. To easily distinguish the interface concerned the messages received or sent from this unit are prefixed with either 'MAP' for a MAP message, 'A' for an A-Interface message, 'Iu' for an Iu-Interface message or 'T' for an ISDN/PSTN message. The procedure in functional unit 3 include:

- i) inter 3G_MSC handover/relocation from 3G_MSC-A;

This case is initiated by 3G_MSC-A, and includes allocation and establishment of the new radio resources. The procedure is outlined in clauses 8.1.1 and 8.1.2. for UMTS to GSM handover, clauses 8.2.1 and 8.2.2 for GSM to UMTS handover and clauses 8.3.1 and 8.3.2 for relocation.

- ii) intra-3G_MSC UMTS to GSM handovers within the area controlled by 3G_MSC-B;

This procedure is the same as that of ii) in clause 11.3, except that the Iu-RELOCATION-REQUIRED is received by 3G_MSC-B. After successful completion of the intra-3G_MSC handover, 3G_MSC-B shall notify 3G_MSC-A by sending an A-HANDOVER-PERFORMED message.

- iii) intra-3G_MSC GSM to UMTS handovers within the area controlled by 3G_MSC-B;

This procedure is the same as that of ii) in clause 11.3, except that the A-HANDOVER-REQUIRED is received by 3G_MSC-B. After successful completion of the intra-3G_MSC handover, 3G_MSC-B shall notify 3G_MSC-A by sending an A-HANDOVER-PERFORMED message.

- iv) intra-3G_MSC SRNS Relocation within the area controlled by 3G_MSC-B;

This procedure is the same as that of ii) in clause 11.3, except that the Iu-RELOCATION-REQUIRED is received by 3G_MSC-B. After successful completion of the intra-3G_MSC SRNS relocation, if security algorithms have been changed, 3G_MSC-B shall notify 3G_MSC-A by sending an A-HANDOVER-PERFORMED or an Iu-LOCATION-REPORT message, depending on the access network protocol used encapsulated on the E-interface (see subclauses 4.4.1 and 6.2.3).

- v) subsequent handover/relocation to another 3G_MSC (3G_MSC-A or 3G_MSC-B);

The initiation procedure is essentially the same as that of i) of clause 11.3. The Handover Command to the BSS or the Relocation Command to the RNS is now generated by 3G_MSC-B after the A-HO-REQUEST-ACKNOWLEDGE or Iu-RELOCATION-REQUEST-ACKNOWLEDGE is received from 3G_MSC-A (via functional unit 4). The procedure is terminated in 3G_MSC-B when 3G_MSC-B receives a terminate procedure indication from functional unit 4.

NOTE: The procedures iii), iv) and, in case of a subsequent handover back to 3G_MSC-A, the procedure v) may be applied also in case of a handover/relocation to an RNC which is controlled by 3G_MSC-B or 3G_MSC-A respectively by using the "Flexible Iu interface for handover/relocation" option.

***** NEXT MODIFIED SECTION *****

12.7 Protocol interworking

If the 3G_MSC-B accepts an Inter-3G_MSC GSM to UMTS handover procedure according to MAP and BSSMAP protocols while using a RANAP protocol towards RNS-B, 3G_MSC-B has to perform the protocol interworking between RANAP on the Iu-Interface and encapsulated BSSMAP on the E-interface.

The same holds if 3G_MSC-B initiates a subsequent inter-MSC UMTS to GSM handover while using a RANAP protocol towards RNS-A.

If during the supervision, i.e. while the UE/MS is not in the area of MSC-A or 3G_MSC-A, the protocol used encapsulated on the E-interface and the protocol used between 3G_MSC-B and the serving BSS or RNS are different, then 3G_MSC-B has to perform the protocol interworking between BSSAP and RANAP.

NOTE: The two protocols are different, e.g., after an inter-MSC GSM to UMTS inter-system handover, or after an inter-MSC SRNS relocation to 3G_MSC-B followed by a subsequent intra-3G_MSC-B UMTS to GSM inter-system handover.

CHANGE REQUEST

⌘ **24.007 CR 042** ⌘ ev **1** ⌘ Current version: **3.7.0** ⌘

For **HELP** on using this form, see bottom of this page or look at the pop-up text over the ⌘ symbols.

Proposed change affects: ⌘ (U)SIM ME/UE Radio Access Network Core Network

Title:	⌘ Clarification of the send sequence number mechanism		
Source:	⌘ Siemens AG		
Work item code:	⌘ GSM/UMTS interworking	Date:	⌘ 16.11.01
Category:	⌘ F	Release:	⌘ R99
	<p>Use <u>one</u> of the following categories:</p> <p>F (correction)</p> <p>A (corresponds to a correction in an earlier release)</p> <p>B (addition of feature),</p> <p>C (functional modification of feature)</p> <p>D (editorial modification)</p> <p>Detailed explanations of the above categories can be found in 3GPP TR 21.900.</p>		<p>Use <u>one</u> of the following releases:</p> <p>2 (GSM Phase 2)</p> <p>R96 (Release 1996)</p> <p>R97 (Release 1997)</p> <p>R98 (Release 1998)</p> <p>R99 (Release 1999)</p> <p>REL-4 (Release 4)</p> <p>REL-5 (Release 5)</p>

Reason for change:	⌘ <p>1) A R99 network must be able to handle the case when N(SD) is operated modulo 2. This will happen when there is an access from a R98 mobile station (or older). The way it is specified now, it reads that N(SD) shall be operated modulo 4 also in this case (without exception), which is not correct for an R98 mobile station (or older).</p> <p>2) Additionally, the text that was included in 24.007 was based on version 8.7.0 of 04.18. A clarification of that text was introduced by GERAN when 04.18 was updated from version 8.8.0 to 8.9.0. The same clarification therefore needs to be included in 24.007.</p> <p>3) The Test Control protocol (TC) does not use layer 3 sequence numbering. Furthermore, the GCC, BCC, and LCS protocol only support modulo 2 operation for the send sequence number, even for R99 and later.</p>
Summary of change:	⌘ <p>It is clarified that, when the MS is R98 or older, the N(SD) shall be operated modulo 2 in the NW.</p> <p>Furthermore, the requirement for R98 or older networks was deleted.</p> <p>For the GCC, BCC, and LCS protocol, V(SD) and N(SD) shall be operated modulo 2.</p> <p>The transfer execution is clarified based on version 8.9.0 of 04.18.</p>
Consequences if not approved:	⌘ <p>In case a R98 or older MS accesses a R99 or later NW, the N(SD) mechanism will be unsynchronized.</p> <p>Inconsistent specification in case of the GCC, BCC, LCS and TC protocol. In case of a wrong implementation, call setup will not be possible for GCC, BCC and LCS (LMU).</p>

Clauses affected: ⌘ 11.2.3.2.1, 11.2.3.2.2, 11.2.3.2.3, 11.2.3.2.3.1.1, 11.2.3.2.3.2.2

Other specs affected:	⌘ <input type="checkbox"/>	Other core specifications	⌘	
	<input type="checkbox"/>	Test specifications		
	<input type="checkbox"/>	O&M Specifications		
Other comments:	⌘			

How to create CRs using this form:

Comprehensive information and tips about how to create CRs can be found at: http://www.3gpp.org/3G_Specs/CRs.htm. Below is a brief summary:

- 1) Fill out the above form. The symbols above marked ⌘ contain pop-up help information about the field that they are closest to.
- 2) Obtain the latest version for the release of the specification to which the change is proposed. Use the MS Word "revision marks" feature (also known as "track changes") when making the changes. All 3GPP specifications can be downloaded from the 3GPP server under <ftp://ftp.3gpp.org/specs/> For the latest version, look for the directory name with the latest date e.g. 2001-03 contains the specifications resulting from the March 2001 TSG meetings.
- 3) With "track changes" disabled, paste the entire CR form (use CTRL-A to select it) into the specification just in front of the clause containing the first piece of changed text. Delete those parts of the specification which are not relevant to the change request.

11.2.3.2 Message type octet

11.2.3.2.1 Message type octet (when accessing Release 98 and older networks only)

The message type octet is the second in a standard L3 message.

When a standard L3 message is expected, and a message is received that is less than 16 bit long, that message shall be ignored.

When the radio connection started with a core network node of a Release 98 or older network, the message type IE is coded as shown in figure 11.10a.

Bit 8 is encoded as "0"; value "1" is reserved for possible future use as an extension bit. A protocol entity expecting a standard L3 message, and receiving a message containing bit 8 of octet 2 encoded as "1" shall diagnose a "message not defined for the PD" error and treat the message accordingly.

In messages of MM, CC, SS, GCC, BCC, TC (Test Control, see 3GPP TS 04.14 and 3GPP TS 34.109) and LCS protocol sent using the transmission functionality provided by the RR layer to upper layers, and sent from the mobile station or the LMU to the network, bit 7 of octet 2 is used for send sequence number, see section 11.2.3.2.3.

In all other standard layer 3 messages bit 7 is set to a default value. A protocol entity expecting a standard L3 message, and not using the transmission functionality provided by the RR layer, and receiving a message containing bit 7 of octet 2 encoded different to the default value shall diagnose a "message not defined for the PD" error and treat the message accordingly.

The default value for bit 7 is 0 except for the SM protocol where the default value is 1.

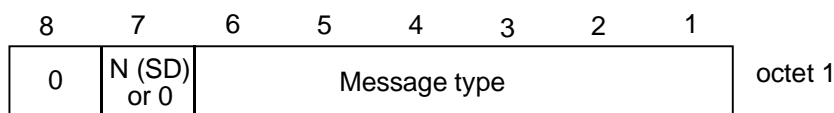

Figure 11.10a: Message type IE

Bit 1 to 6 of octet 2 of standard L3 messages contain the message type.

The message type determines the function of a message within a protocol in a given direction and for a given lower layer SAP. The meaning of the message type is therefore dependent on the protocol (the same value may have different meanings in different protocols), the direction (the same value may have different meanings in the same protocol, when sent from the Mobile Station to the network and when sent from the network to the Mobile Station) and the lower layer SAP (the same value may have different meanings, e.g., whether the message was sent on the SACCH or on the main DCCH).

Each protocol defines a list of allowed message types for each relevant SAP. A message received analysed as a standard L3 message, and with a message type not in the corresponding list leads to the diagnosis "message not defined for the PD". Some message types may correspond to a function not implemented by the receiver. They are then said to be non implemented by the receiver.

The reaction of a protocol entity expecting a standard L3 message and receiving a message with message type not defined for the PD or not implemented by the receiver and the reception conditions is defined in the relevant protocol specification. As a general rule, a protocol specification should not force the receiver to analyse the message further.

11.2.3.2.2 Message type octet (when accessing Release 99 and newer networks)

The message type octet is the second in a standard L3 message.

When a standard L3 message is expected, and a message is received that is less than 16 bit long, that message shall be ignored.

When the radio connection started with a core network node of a Release 99 or later network, the message type IE is coded dependent on the PD as shown in figures 11.10b, c and d11.10e.

In messages of MM, CC, and SS, GCC, BCC, TC (Test Control, see 3GPP TS 04.14 and 3GPP TS 34.109) and LCS protocol sent using the transmission functionality provided by the RR and/or access stratum layer to upper layers, and

sent from the mobile station or the LMU to the network-, bits 7 and 8 of octet 2 are used for send sequence number, see section 11.2.3.2.3.

In messages of GCC, BCC and LCS protocol sent using the transmission functionality provided by the RR layer to upper layers, and sent from the mobile station to the network or, for LCS, sent from the LMU to the network, only bit 7 of octet 2 is used for send sequence number. Bit 8 is set to the default value.

In all other standard layer 3 messages bits 7 and 8 are set to the default value. A protocol entity expecting a standard L3 message, and not using the transmission functionality provided by the RR and/or access stratum layer, and receiving a message containing bit 7 or bit 8 of octet 2 encoded different to the default value shall diagnose a "message not defined for the PD" error and treat the message accordingly.

The default value for bit 8 is 0. The default value for bit 7 is 0 except for the SM protocol which has a default value of 1.

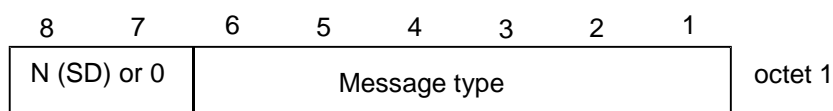

Figure 11.10b: Message type IE (MM, CC, and SS, GCC, BCC, TC and LCS)

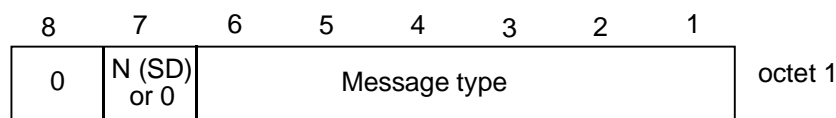

Figure 11.10c: Message type IE (GCC, BCC and LCS)

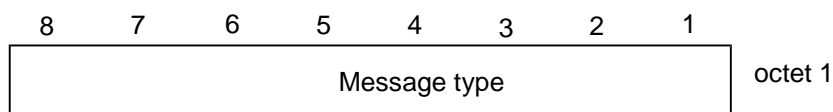

Figure 11.10ed: Message type IE (protocol other than MM, CC, SS, GCC, BCC, TC and LCS)

Bit 1 to 6 of octet 2 of standard L3 messages contain the message type.

The message type determines the function of a message within a protocol in a given direction and for a given lower layer SAP. The meaning of the message type is therefore dependent on the protocol (the same value may have different meanings in different protocols), the direction (the same value may have different meanings in the same protocol, when sent from the Mobile Station to the network and when sent from the network to the Mobile Station) and the lower layer SAP (the same value may have different meanings, e.g., whether the message was sent on the SACCH or on the main DCCH).

Each protocol defines a list of allowed message types for each relevant SAP. A message received analysed as a standard L3 message, and with a message type not in the corresponding list leads to the diagnosis "message not defined for the PD". Some message types may correspond to a function not implemented by the receiver. They are then said to be non implemented by the receiver.

The reaction of a protocol entity expecting a standard L3 message and receiving a message with message type not defined for the PD or not implemented by the receiver and the reception conditions is defined in the relevant protocol specification. As a general rule, a protocol specification should not force the receiver to analyse the message further.

11.2.3.2.3 Sequenced message transfer operation

Upper layer messages sent using the RR sub-layer transport service from the mobile station to the network can be duplicated by the data link layer in at least the following cases:

- in A/Gb mode, when a channel change of dedicated channels is required (assignment or handover procedure) and the last layer 2 frame has not been acknowledged by the peer data link layer before the mobile station leaves the old channel.

- in Iu mode, when an RLC re-establishment occurs (e.g. due to relocation) and the RLC layer has not acknowledged the last one or more RLC PDUs before RLC re-establishment
- an inter-system change from Iu mode to A/Gb mode is performed and the RLC layer has not acknowledged the last one or more RLC PDUs.
- an inter-system change from A/Gb mode to Iu mode is performed and the the last layer 2 frame in A/Gb mode has not been acknowledged by the peer data link layer before the mobile station leaves the old channel.

In these cases, the mobile station does not know whether the network has received the messages correctly. Therefore, the mobile station has to send the messages again when the channel change is completed.

The network must be able to detect the duplicated received messages. Therefore, each concerned upper layer messages must be marked with a send sequence number.

To allow for different termination points in the infrastructure of the messages of different PDs, the sequence numbering is specific to each PD. For historical reasons, an exception is that messages sent with the CC, SS and MM PDs share the same sequence numbering. In the following, the phrase **upper layer message flow** refers to a flow of messages sharing the same sequence numbering. The different upper layer flows are MM+CC+SS, GCC, BCC, ~~TC (Test Control, see 3GPP TS 04.14 and 3GPP TS 34.109)~~ and LCS. The GMM, SM, ~~and SMS and TC (Test Control, see 3GPP TS 04.14 and 3GPP TS 34.109)~~ protocols do not use layer 3 sequence numbering.

11.2.3.2.3.1 Variables and sequence numbers

11.2.3.2.3.1.1 Send state variable V(SD)

The mobile station shall have one associated send state variable V(SD) ("Send Duplicated") for each upper layer message flow. The send state variable denotes the sequence number of the next in sequence numbered message in the flow to be transmitted. The value of the corresponding send state variable shall be incremented by one with each numbered message transmission.

~~For the MM+CC+SS upper layer message flow, w~~When the RR connection starts with a core network of release 98 or earlier, arithmetic operations on V(SD) are performed modulo 2. When the RR connection starts with a core network of Release 99 or later, arithmetic operations on V(SD) are performed modulo 4. The mobile station shall keep using the same modulo (2 or 4) for the duration of the RR connection.

For the GCC, BCC, and LCS upper layer message flows, arithmetic operations on V(SD) are performed modulo 2.

NOTE: In GSM, the release supported by the core network is broadcast as system information.

11.2.3.2.3.1.2 Send sequence number N(SD)

At the time when such a message to be numbered is designated for transmission, the value of N(SD) for the message to be transferred is set equal to the value of the send state variable V(SD).

11.2.3.2.3.2 Procedures for the initiation, transfer execution and termination of the sequenced message transfer operation

11.2.3.2.3.2.1 Initiation

The sequenced message transfer operation is initiated by establishing a RR connection. The send state variables V(SD) are set to 0.

11.2.3.2.3.2.2 Transfer Execution

~~A release 98 or earlier~~The core network must compare the send sequence numbers of pairs of subsequent messages in the same upper layer messages flow.

For the GCC, BCC, and LCS upper layer message flows, in case the send sequence numbers of two subsequent messages in a flow are not identical, no duplication has occurred. In case the send sequence numbers are identical, the network must ignore the second one of the received messages.

For the MM+CC+SS upper layer message flow:

- when accessed by a release 98 or earlier mobile station, in case the send sequence numbers of two subsequent messages in the flow are identical, the core network shall discard the second one of the received messages;
- when accessed by a release 99 or later mobile station, a release 99 or later the core network shall discard any message whose N(SD) is not ~~greater~~ the increment by one (modulo 4) ~~than~~ of the N(SD) of the last accepted message.

NOTE: The release supported by the mobile station is indicated by the revision level in *the Mobile Station Classmark 1* or *Mobile Station Classmark 2* information element, or by the revision level indicator in the *MS network capability* information element (see 3GPP TS 24.008, subclause 10.5).

11.2.3.2.3.2.3 Termination

The sequenced message transfer operation is terminated by the RR connection release procedure.

Inter system change from A/Gb mode to Iu mode or from Iu mode to A/Gb mode shall not terminate the sequenced message transfer. UMTS SRNC relocation shall not terminate the sequenced message transfer.

CHANGE REQUEST

⌘ **24.007 CR 043** ⌘ ev **1** ⌘ Current version: **4.0.0** ⌘

For **HELP** on using this form, see bottom of this page or look at the pop-up text over the ⌘ symbols.

Proposed change affects: ⌘ (U)SIM ME/UE Radio Access Network Core Network

Title:	⌘ Clarification of the send sequence number mechanism		
Source:	⌘ Siemens AG		
Work item code:	⌘ GSM/UMTS interworking	Date:	⌘ 16.11.01
Category:	⌘ A F	Release:	⌘ Rel-499
	<p>Use <u>one</u> of the following categories:</p> <p>F (correction) A (corresponds to a correction in an earlier release) B (addition of feature), C (functional modification of feature) D (editorial modification)</p> <p>Detailed explanations of the above categories can be found in 3GPP TR 21.900.</p>		<p>Use <u>one</u> of the following releases:</p> <p>2 (GSM Phase 2) R96 (Release 1996) R97 (Release 1997) R98 (Release 1998) R99 (Release 1999) REL-4 (Release 4) REL-5 (Release 5)</p>

Reason for change:	⌘ <p>1) A R99 network must be able to handle the case when N(SD) is operated modulo 2. This will happen when there is an access from a R98 mobile station (or older). The way it is specified now, it reads that N(SD) shall be operated modulo 4 also in this case (without exception), which is not correct for an R98 mobile station (or older).</p> <p>2) Additionally, the text that was included in 24.007 was based on version 8.7.0 of 04.18. A clarification of that text was introduced by GERAN when 04.18 was updated from version 8.8.0 to 8.9.0. The same clarification therefore needs to be included in 24.007.</p> <p>3) The Test Control protocol (TC) does not use layer 3 sequence numbering. Furthermore, the GCC, BCC, and LCS protocol only support modulo 2 operation for the send sequence number, even for R99 and later.</p>
Summary of change:	⌘ <p>It is clarified that, when the MS is R98 or older, the N(SD) shall be operated modulo 2 in the NW.</p> <p>Furthermore, the requirement for R98 or older networks was deleted.</p> <p>For the GCC, BCC, and LCS protocol, V(SD) and N(SD) shall be operated modulo 2.</p> <p>The transfer execution is clarified based on version 8.9.0 of 04.18.</p>
Consequences if not approved:	⌘ <p>In case a R98 or older MS accesses a R99 or later NW, the N(SD) mechanism will be unsynchronized.</p> <p>Inconsistent specification in case of the GCC, BCC, LCS and TC protocol. In case of a wrong implementation, call setup will not be possible for GCC, BCC and LCS (LMU).</p>

Clauses affected:	⌘	11.2.3.2.1, 11.2.3.2.2, 11.2.3.2.3, 11.2.3.2.3.1.1, 11.2.3.2.3.2.2
Other specs affected:	⌘	<input type="checkbox"/> Other core specifications <input type="checkbox"/> Test specifications <input type="checkbox"/> O&M Specifications
Other comments:	⌘	

How to create CRs using this form:

Comprehensive information and tips about how to create CRs can be found at: http://www.3gpp.org/3G_Specs/CRs.htm. Below is a brief summary:

- 1) Fill out the above form. The symbols above marked ⌘ contain pop-up help information about the field that they are closest to.
- 2) Obtain the latest version for the release of the specification to which the change is proposed. Use the MS Word "revision marks" feature (also known as "track changes") when making the changes. All 3GPP specifications can be downloaded from the 3GPP server under <ftp://ftp.3gpp.org/specs/>. For the latest version, look for the directory name with the latest date e.g. 2001-03 contains the specifications resulting from the March 2001 TSG meetings.
- 3) With "track changes" disabled, paste the entire CR form (use CTRL-A to select it) into the specification just in front of the clause containing the first piece of changed text. Delete those parts of the specification which are not relevant to the change request.

11.2.3.2 Message type octet

11.2.3.2.1 Message type octet (when accessing Release 98 and older networks only)

The message type octet is the second in a standard L3 message.

When a standard L3 message is expected, and a message is received that is less than 16 bit long, that message shall be ignored.

When the radio connection started with a core network node of a Release 98 or older network, the message type IE is coded as shown in figure 11.10a.

Bit 8 is encoded as "0"; value "1" is reserved for possible future use as an extension bit. A protocol entity expecting a standard L3 message, and receiving a message containing bit 8 of octet 2 encoded as "1" shall diagnose a "message not defined for the PD" error and treat the message accordingly.

In messages of MM, CC, SS, GCC, BCC, ~~TC (Test Control, see 3GPP TS 04.14 and 3GPP TS 34.109)~~ and LCS protocol sent using the transmission functionality provided by the RR layer to upper layers, and sent from the mobile station or the LMU to the network, bit 7 of octet 2 is used for send sequence number, see section 11.2.3.2.3.

In all other standard layer 3 messages bit 7 is set to a default value. A protocol entity expecting a standard L3 message, and not using the transmission functionality provided by the RR layer, and receiving a message containing bit 7 of octet 2 encoded different to the default value shall diagnose a "message not defined for the PD" error and treat the message accordingly.

The default value for bit 7 is 0 except for the SM protocol where the default value is 1.

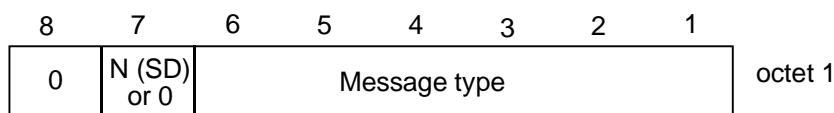

Figure 11.10a: Message type IE

Bit 1 to 6 of octet 2 of standard L3 messages contain the message type.

The message type determines the function of a message within a protocol in a given direction and for a given lower layer SAP. The meaning of the message type is therefore dependent on the protocol (the same value may have different meanings in different protocols), the direction (the same value may have different meanings in the same protocol, when sent from the Mobile Station to the network and when sent from the network to the Mobile Station) and the lower layer SAP (the same value may have different meanings, e.g., whether the message was sent on the SACCH or on the main DCCH).

Each protocol defines a list of allowed message types for each relevant SAP. A message received analysed as a standard L3 message, and with a message type not in the corresponding list leads to the diagnosis "message not defined for the PD". Some message types may correspond to a function not implemented by the receiver. They are then said to be non implemented by the receiver.

The reaction of a protocol entity expecting a standard L3 message and receiving a message with message type not defined for the PD or not implemented by the receiver and the reception conditions is defined in the relevant protocol specification. As a general rule, a protocol specification should not force the receiver to analyse the message further.

11.2.3.2.2 Message type octet (when accessing Release 99 and newer networks)

The message type octet is the second in a standard L3 message.

When a standard L3 message is expected, and a message is received that is less than 16 bit long, that message shall be ignored.

When the radio connection started with a core network node of a Release 99 or later network, the message type IE is coded dependent on the PD as shown in figures 11.10b, c and d~~11.10e~~.

In messages of MM, CC, and SS, GCC, BCC, ~~TC (Test Control, see 3GPP TS 04.14 and 3GPP TS 34.109)~~ and LCS protocol sent using the transmission functionality provided by the RR and/or access stratum layer to upper layers, and

sent from the mobile station or the LMU to the network, bits 7 and 8 of octet 2 are used for send sequence number, see section 11.2.3.2.3.

In messages of GCC, BCC and LCS protocol sent using the transmission functionality provided by the RR layer to upper layers, and sent from the mobile station to the network or, for LCS, sent from the LMU to the network, only bit 7 of octet 2 is used for send sequence number. Bit 8 is set to the default value.

In all other standard layer 3 messages bits 7 and 8 are set to the default value. A protocol entity expecting a standard L3 message, and not using the transmission functionality provided by the RR and/or access stratum layer, and receiving a message containing bit 7 or bit 8 of octet 2 encoded different to the default value shall diagnose a "message not defined for the PD" error and treat the message accordingly.

The default value for bit 8 is 0. The default value for bit 7 is 0 except for the SM protocol which has a default value of 1.

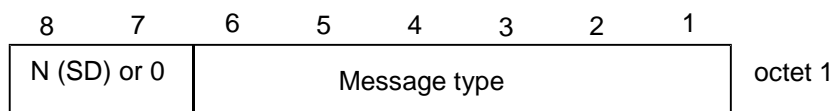

Figure 11.10b: Message type IE (MM, CC, and SS, GCC, BCC, TC and LCS)

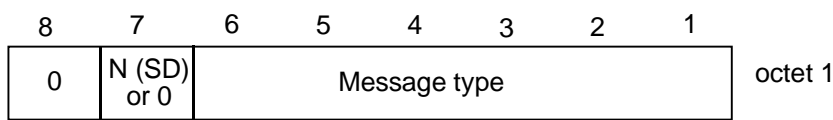

Figure 11.10c: Message type IE (GCC, BCC and LCS)

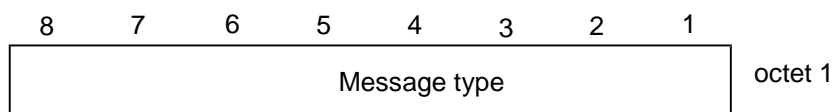

Figure 11.10d: Message type IE (protocol other than MM, CC, SS, GCC, BCC, TC and LCS)

Bit 1 to 6 of octet 2 of standard L3 messages contain the message type.

The message type determines the function of a message within a protocol in a given direction and for a given lower layer SAP. The meaning of the message type is therefore dependent on the protocol (the same value may have different meanings in different protocols), the direction (the same value may have different meanings in the same protocol, when sent from the Mobile Station to the network and when sent from the network to the Mobile Station) and the lower layer SAP (the same value may have different meanings, e.g., whether the message was sent on the SACCH or on the main DCCH).

Each protocol defines a list of allowed message types for each relevant SAP. A message received analysed as a standard L3 message, and with a message type not in the corresponding list leads to the diagnosis "message not defined for the PD". Some message types may correspond to a function not implemented by the receiver. They are then said to be non implemented by the receiver.

The reaction of a protocol entity expecting a standard L3 message and receiving a message with message type not defined for the PD or not implemented by the receiver and the reception conditions is defined in the relevant protocol specification. As a general rule, a protocol specification should not force the receiver to analyse the message further.

11.2.3.2.3 Sequenced message transfer operation

Upper layer messages sent using the RR sub-layer transport service from the mobile station to the network can be duplicated by the data link layer in at least the following cases:

- in A/Gb mode, when a channel change of dedicated channels is required (assignment or handover procedure) and

the last layer 2 frame has not been acknowledged by the peer data link layer before the mobile station leaves the old channel.

- in Iu mode, when an RLC re-establishment occurs (e.g. due to relocation) and the RLC layer has not acknowledged the last one or more RLC PDUs before RLC re-establishment
- an inter-system change from Iu mode to A/Gb mode is performed and the RLC layer has not acknowledged the last one or more RLC PDUs.
- an inter-system change from A/Gb mode to Iu mode is performed and the the last layer 2 frame in A/Gb mode has not been acknowledged by the peer data link layer before the mobile station leaves the old channel.

In these cases, the mobile station does not know whether the network has received the messages correctly. Therefore, the mobile station has to send the messages again when the channel change is completed.

The network must be able to detect the duplicated received messages. Therefore, each concerned upper layer messages must be marked with a send sequence number.

To allow for different termination points in the infrastructure of the messages of different PDs, the sequence numbering is specific to each PD. For historical reasons, an exception is that messages sent with the CC, SS and MM PDs share the same sequence numbering. In the following, the phrase **upper layer message flow** refers to a flow of messages sharing the same sequence numbering. The different upper layer flows are MM+CC+SS, GCC, BCC, ~~TC (Test Control, see 3GPP TS 04.14 and 3GPP TS 34.109)~~ and LCS. The GMM, SM, ~~and SMS~~ and TC (Test Control, see 3GPP TS 04.14 and 3GPP TS 34.109) protocols do not use layer 3 sequence numbering.

11.2.3.2.3.1 Variables and sequence numbers

11.2.3.2.3.1.1 Send state variable V(SD)

The mobile station shall have one associated send state variable V(SD) ("Send Duplicated") for each upper layer message flow. The send state variable denotes the sequence number of the next in sequence numbered message in the flow to be transmitted. The value of the corresponding send state variable shall be incremented by one with each numbered message transmission.

For the MM+CC+SS upper layer message flow, wWhen the RR connection starts with a core network of release 98 or earlier, arithmetic operations on V(SD) are performed modulo 2. When the RR connection starts with a core network of Release 99 or later, arithmetic operations on V(SD) are performed modulo 4. The mobile station shall keep using the same modulo (2 or 4) for the duration of the RR connection.

For the GCC, BCC, and LCS upper layer message flows, arithmetic operations on V(SD) are performed modulo 2.

NOTE: In GSM, the release supported by the core network is broadcast as system information.

11.2.3.2.3.1.2 Send sequence number N(SD)

At the time when such a message to be numbered is designated for transmission, the value of N(SD) for the message to be transferred is set equal to the value of the send state variable V(SD).

11.2.3.2.3.2 Procedures for the initiation, transfer execution and termination of the sequenced message transfer operation

11.2.3.2.3.2.1 Initiation

The sequenced message transfer operation is initiated by establishing a RR connection. The send state variables V(SD) are set to 0.

11.2.3.2.3.2.2 Transfer Execution

~~A release 98 or earlier~~The core network must compare the send sequence numbers of pairs of subsequent messages in the same upper layer messages flow.

For the GCC, BCC, and LCS upper layer message flows, in case the send sequence numbers of two subsequent messages in a flow are not identical, no duplication has occurred. In case the send sequence numbers are identical, the network must ignore the second one of the received messages.

For the MM+CC+SS upper layer message flow:

- when accessed by a release 98 or earlier mobile station, in case the send sequence numbers of two subsequent messages in the flow are identical, the core network shall discard the second one of the received messages;
- when accessed by a release 99 or later mobile station, the core network shall discard any message whose N(SD) is not ~~greater~~ greater the increment by one (modulo 4) than the N(SD) of the last accepted message.

NOTE: The release supported by the mobile station is indicated by the revision level in *the Mobile Station Classmark 1* or *Mobile Station Classmark 2* information element, or by the revision level indicator in the *MS network capability* information element (see 3GPP TS 24.008, subclause 10.5).

11.2.3.2.3.2.3 Termination

The sequenced message transfer operation is terminated by the RR connection release procedure.

Inter system change from A/Gb mode to Iu mode or from Iu mode to A/Gb mode shall not terminate the sequenced message transfer. UMTS SRNC relocation shall not terminate the sequenced message transfer.

CR-Form-v5

CHANGE REQUEST

⌘ **23.009 CR 056** ⌘ rev **2** ⌘ Current version: **3.8.0** ⌘

For **HELP** on using this form, see bottom of this page or look at the pop-up text over the ⌘ symbols.

Proposed change affects: ⌘ (U)SIM ME/UE Radio Access Network Core Network

Title:	⌘ Usage of Location Reporting for Relocation and Inter-system Handover		
Source:	⌘ Ericsson		
Work item code:	⌘ GSM – UMTS Interworking	Date:	⌘ 01-11-26
Category:	⌘ F (Agreed by consensus) Use <u>one</u> of the following categories: F (correction) A (corresponds to a correction in an earlier release) B (addition of feature), C (functional modification of feature) D (editorial modification) Detailed explanations of the above categories can be found in 3GPP TR 21.900.	Release:	⌘ R99 Use <u>one</u> of the following releases: 2 (GSM Phase 2) R96 (Release 1996) R97 (Release 1997) R98 (Release 1998) R99 (Release 1999) REL-4 (Release 4) REL-5 (Release 5)

Reason for change:	⌘ SDL to align with CR 048 approved at CN#13, NP-010494.
Summary of change:	⌘ Check on the first branch to see whether Location Reporting is supported or not in 3G_MSC-B.
Consequences if not approved:	⌘ Not accordin to the text.

Clauses affected:	⌘ Figure 44 (sheet 44 of 54): Handover control procedure in 3G_MSC-B	
Other specs affected:	⌘ <input type="checkbox"/> Other core specifications	⌘ <input type="checkbox"/>
	<input type="checkbox"/> Test specifications	
	<input type="checkbox"/> O&M Specifications	
Other comments:	⌘	

How to create CRs using this form:

Comprehensive information and tips about how to create CRs can be found at: http://www.3gpp.org/3G_Specs/CRs.htm. Below is a brief summary:

- 1) Fill out the above form. The symbols above marked ⌘ contain pop-up help information about the field that they are closest to.
- 2) Obtain the latest version for the release of the specification to which the change is proposed. Use the MS Word "revision marks" feature (also known as "track changes") when making the changes. All 3GPP specifications can be downloaded from the 3GPP server under <ftp://ftp.3gpp.org/specs/>. For the latest version, look for the directory name with the latest date e.g. 2001-03 contains the specifications resulting from the March 2001 TSG meetings.
- 3) With "track changes" disabled, paste the entire CR form (use CTRL-A to select it) into the specification just in front of the clause containing the first piece of changed text. Delete those parts of the specification which are not relevant to the change request.

Procedure 3G_MSC_B_HO

Sheet44(54)

Procedures for Handover in 3G_MSC-B

SRNS Relocation from RNS-A to RNS-B on 3G_MSC-B

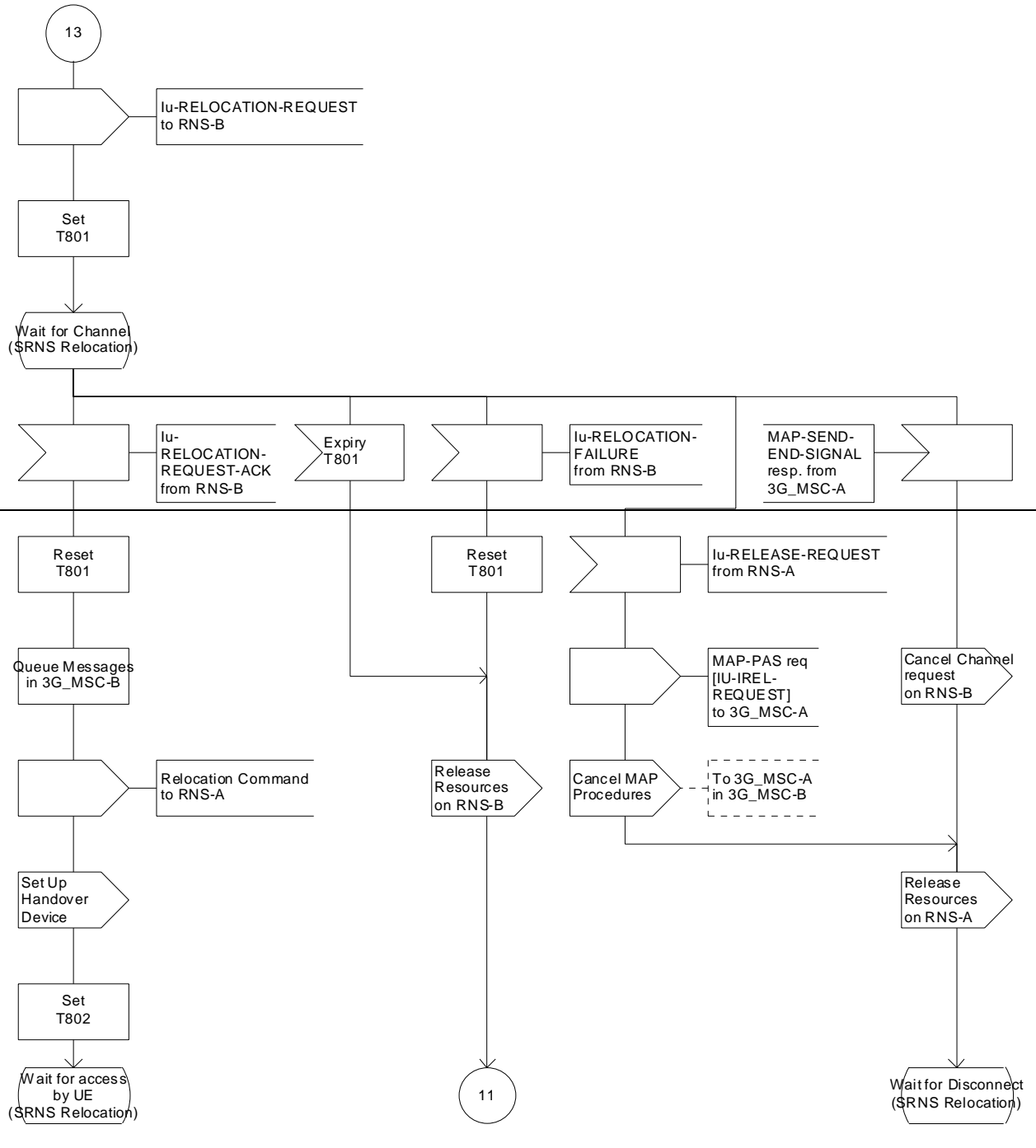

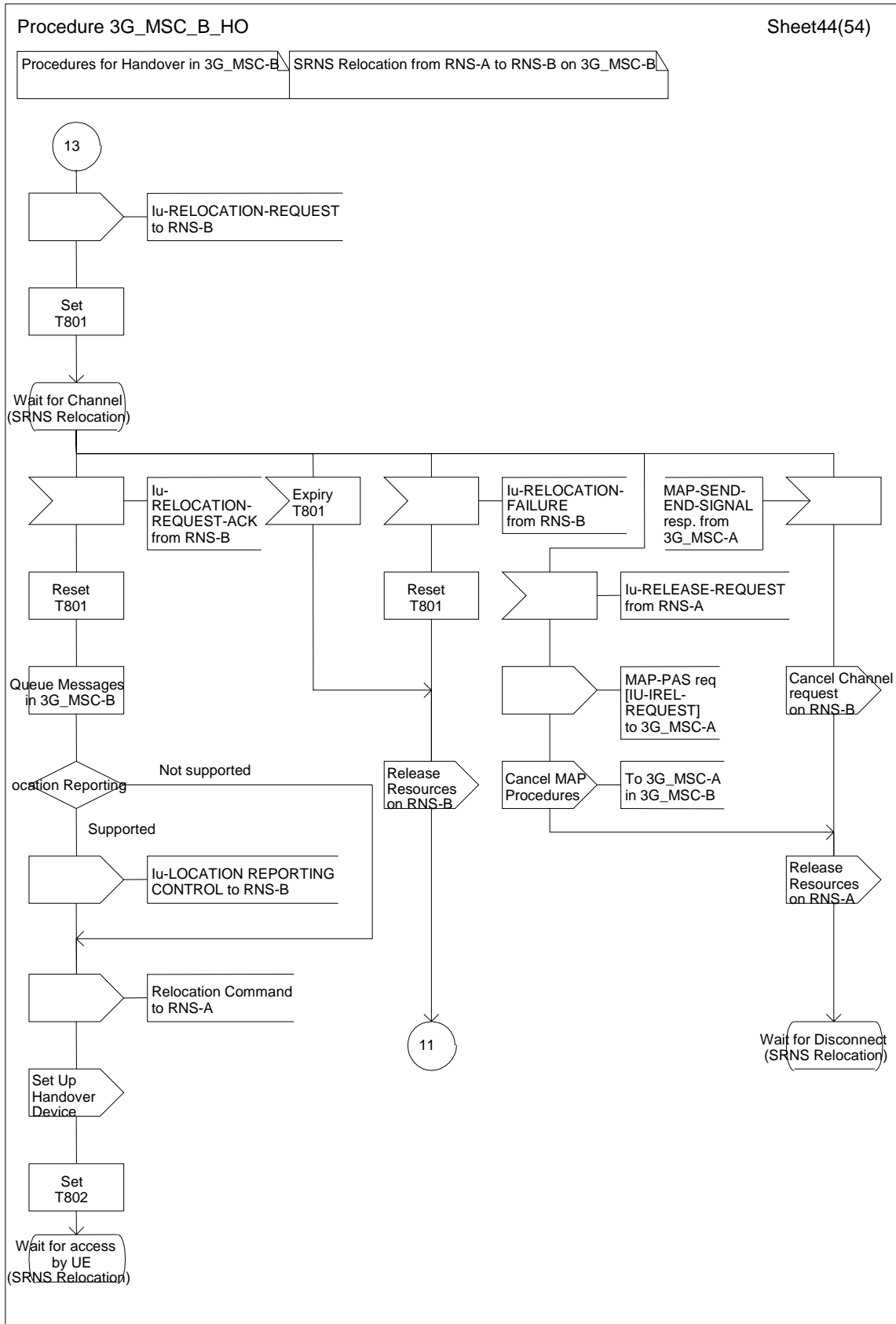

CR-Form-v5
CHANGE REQUEST
⌘ 23.009 CR 057 ⌘ rev 2 ⌘ Current version: 4.2.0 ⌘

For **HELP** on using this form, see bottom of this page or look at the pop-up text over the ⌘ symbols.

Proposed change affects: ⌘ (U)SIM ME/UE Radio Access Network Core Network

Title:	⌘ Usage of Location Reporting for Relocation and Inter-system Handover		
Source:	⌘ Ericsson		
Work item code:	⌘ GSM – UMTS Interworking	Date:	⌘ 01-11-26
Category:	⌘ A (Agreed by consensus) Use <u>one</u> of the following categories: F (correction) A (corresponds to a correction in an earlier release) B (addition of feature), C (functional modification of feature) D (editorial modification) Detailed explanations of the above categories can be found in 3GPP TR 21.900.	Release:	⌘ R4 Use <u>one</u> of the following releases: 2 (GSM Phase 2) R96 (Release 1996) R97 (Release 1997) R98 (Release 1998) R99 (Release 1999) REL-4 (Release 4) REL-5 (Release 5)

Reason for change:	⌘ SDL to align with CR 049 approved at CN#13, NP-010494.
Summary of change:	⌘ Check on the first branch to see whether Location Reporting is supported or not in 3G_MSC-B.
Consequences if not approved:	⌘ Not accordin to the text.

Clauses affected:	⌘ Figure 44 (sheet 44 of 54): Handover control procedure in 3G_MSC-B		
Other specs affected:	⌘ <input type="checkbox"/> Other core specifications <input type="checkbox"/> Test specifications <input type="checkbox"/> O&M Specifications	⌘	
Other comments:	⌘		

How to create CRs using this form:

Comprehensive information and tips about how to create CRs can be found at: http://www.3gpp.org/3G_Specs/CRs.htm. Below is a brief summary:

- 1) Fill out the above form. The symbols above marked ⌘ contain pop-up help information about the field that they are closest to.
- 2) Obtain the latest version for the release of the specification to which the change is proposed. Use the MS Word "revision marks" feature (also known as "track changes") when making the changes. All 3GPP specifications can be downloaded from the 3GPP server under <ftp://ftp.3gpp.org/specs/> For the latest version, look for the directory name with the latest date e.g. 2001-03 contains the specifications resulting from the March 2001 TSG meetings.
- 3) With "track changes" disabled, paste the entire CR form (use CTRL-A to select it) into the specification just in front of the clause containing the first piece of changed text. Delete those parts of the specification which are not relevant to the change request.

Procedure 3G_MSC_B_HO

Sheet44(54)

Procedures for Handover in 3G_MSC-B

SRNS Relocation from RNS-A to RNS-B on 3G_MSC-B

