

Plenary Meeting #9, Oahu, Hawaii
20th – 22nd September 2000.

Source: TSG_N WG 3
Title: CRs to R99 Work Item T.E.I (CS Data Services) part 2 of 4
Agenda item: 8.6.3
Document for: APPROVAL

Introduction:

This document contains 7 CRs on **R99 Work Item T.E.I (CS Data Services)**, that has been agreed by **TSG_N WG3**, and is forwarded to TSG_N Plenary meeting #9 for approval.

Doc-2nd-	Spec	CR	Rev	Phase	Subject	Cat	to Version-
N3-000450	24.022	005	1	R99	Relevance of GSM specific BC-IE parameters for negotiating RLP	F	3.3.0
N3-000441	27.001	024	1	R00	UMTS clean-up	A	4.0.0
N3-000366	27.001	025		R99	Relevance of GSM specific BC-IE parameters for negotiating RLP	F	3.5.0
N3-000372	27.001	028		R00	Relevance of GSM specific BC-IE parameters for negotiating RLP	A	4.0.0
N3-000440	27.001	030	1	R99	UMTS clean-up	F	3.5.0
N3-000428	27.001	036		R00	Clarification related to RCR	D	4.0.0
N3-000429	29.007	028		R00	Clarification related to RCR	D	3.5.0

3GPP N3 Meeting #12
Seattle, US, 28 August -1 September 2000

Document N3-000450

e.g. for 3GPP use the format TP-99xxx
 or for SMG, use the format P-99-xxx

<h2 style="margin: 0;">CHANGE REQUEST</h2>		<i>Please see embedded help file at the bottom of this page for instructions on how to fill in this form correctly.</i>
24.022	CR	005r1
<small>GSM (AA.BB) or 3G (AA.BBB) specification number ↑</small>		<small>↑ CR number as allocated by MCC support team</small>
For submission to: CN#9 <small>list expected approval meeting # here ↑</small>		Current Version: 3.3.0
for approval <input checked="" type="checkbox"/>		strategic <input type="checkbox"/>
for information <input type="checkbox"/>		non-strategic <input type="checkbox"/> <small>(for SMG Use only)</small>

Form: CR cover sheet, version 2 for 3GPP and SMG The latest version of this form is available from: <ftp://ftp.3gpp.org/Information/CR-Form-v2.doc>

Proposed change affects: (U)SIM ME UTRAN / Radio Core Network
(at least one should be marked with an X)

Source: TSG_N3 **Date:** 2000-08-29

Subject: Relevance of GSM specific BC-IE parameters for negotiating RLP version in UMTS

Work item: TEI

Category:	F Correction <input checked="" type="checkbox"/> A Corresponds to a correction in an earlier release <input type="checkbox"/> B Addition of feature <input type="checkbox"/> C Functional modification of feature <input type="checkbox"/> D Editorial modification <input type="checkbox"/>	Release:	Phase 2 <input type="checkbox"/> Release 96 <input type="checkbox"/> Release 97 <input type="checkbox"/> Release 98 <input type="checkbox"/> Release 99 <input checked="" type="checkbox"/> Release 00 <input type="checkbox"/>
------------------	----------------------------------------------------------------------------------------------------------------------------------------------------------------------------------------------------------------------------------------------------------------------------------------------------------	-----------------	------------------------------------------------------------------------------------------------------------------------------------------------------------------------------------------------------------------------------------------------

(only one category shall be marked with an X)

Reason for change: Certain parameters in the BC-IE are specific to the GSM radio channel. These have no relevance for the UTRAN radio access bearer. However, in order to avoid renegotiating the RLP version during a call in case of handover to GSM, they may be used by the RLP entities to negotiate the proper version. This CR also ensures that version 2 is negotiated when EDGE channels are used.

Clauses affected: 3, 5.5

Other specs affected:	Other 3G core specifications <input checked="" type="checkbox"/> Other GSM core specifications <input type="checkbox"/> MS test specifications <input type="checkbox"/> BSS test specifications <input type="checkbox"/> O&M specifications <input type="checkbox"/>	→ List of CRs: 27.001 N3-000366, N3-000372 → List of CRs: → List of CRs: → List of CRs: → List of CRs:
------------------------------	----------------------------------------------------------------------------------------------------------------------------------------------------------------------------------------------------------------------------------------------------------------------------------	--------------------------------------------------------------------------------------------------------------------

Other comments:

3 Introduction

Three versions of RLP are defined:

- RLP version 0: single-link basic version;
- RLP version 1: single-link extended version (e.g. extended by data compression);
- RLP version 2: multi-link version.

RLP uses one physical link (single-link) or from 1 up to 4 (multi-link) substreams on one or more physical links. However, the RLP multi-link version is designed to be able to support up to 8 physical links. If, in the call set-up signalling, either end indicates that it cannot support multi-link operation, neither end shall require usage of RLP-versions higher than 1. If the BC negotiation during call set-up results in a possibility for multi-link operation during the call, both ends shall require and accept RLP version 2 only.

If the BC-IE sent by the MS in the SETUP or CALL CONFIRM message indicates negotiation during call set-up results in "maximum number of traffic channels" = "1 TCH" and WAIUR \leq 14.4 kbit/s and the BC-IE sent by the MS in the CALL CONFIRM message (MT case) or by the MSC in the CALL PROCEEDING message (MO case) indicates UIMI = "not required/not allowed" or "up to 1 TCH/F allowed/may be requested/allowed", this ~~is shall be~~ interpreted as if at least one end does not support multi-link operation, and neither end shall require RLP version higher than 1.

RLP makes use of an underlying FEC (Forward Error Correction) mechanism. For RLP to perform adequately it is assumed that the basic radio channel together with FEC provides for a block error rate of less than 10 %, where a block consists of 240 or 576 bits (Further study on the BLER for 576-bit blocks is needed). Furthermore, it is assumed that in case of multi-link RLP the difference of the delay between all physical links is less than timer T4.

In GSM, RLP frames are sent in strict alignment with the radio transmission. (For details, see GSM 04.21). RLP frames are of a fixed size of 240 (TCH/F4.8 and TCH/F9.6 channel codings) or 576 bits (TCH/F14.4, TCH/F28.8 and TCH/F43.2 channel codings). Whenever a frame is to be sent, the RLP entity has to provide the necessary protocol information to be contained in it. In UMTS, the RLP frame size does not depend on the channel coding, only 576 bit frames are used.

RLP entities running only in an UMTS environment need only to support the 576 bit frame length. The REMAP function is not necessary. RLP entities running in both of the systems have to support the REMAP function. In a handover from UMTS to GSM the frame either stays 576 bits long or changes from 576 bits to 240 bits incurring a REMAP. In a handover from GSM to UMTS the frame either stays 576 bits long or changes from 240 bits to 576 bits incurring a REMAP.

Provision is made for discontinuous transmission (DTX).

RLP spans from the Mobile Station (MS) to the interworking function (IWF), located at the nearest Mobile Switching Centre (MSC), or beyond. Depending on the exact location of the IWF, handover of the MS may result in link-reset or even total loss of the connection.

The MS shall initiate the RLP link. In addition the MSC/IWF may initiate the RLP link.

In the terminology of HDLC, RLP is used in a balanced configuration, employing asynchronous operation, i.e. either station has the right to set-up, reset, or disconnect a link at any time. Procedural means are provided for to deal with contentious situations, should they ever occur.

RLP is full-duplex in the sense that it allows for information to be transferred in both directions simultaneously.

5.5 List of system parameters

The system parameters are as follows.

Table 2: RLP parameter values

Name	Range of values	Default value	Recommended value
Version N°	0 – 2	0	2
k MS ⇒ IWF (for N° = 0/1)	0 – 61	61	61
k MS ⇒ IWF (for N° = 2)	0 - k _{max} (note 3)	480	240 (note 2)
k IWF ⇒ MS (for N° = 0/1)	0 – 61	61	61
k IWF ⇒ MS (for N° = 2)	0 - k _{max} (note 3)	480	240 (note 2)
T1 (note 1)	> 420 ms (version2) > 380 ms > 440 ms > 600 ms	520 ms (fullrate on 14,5, 29,0 or 43,5 kbit/s) 480 ms (fullrate on 12 kbit/s) 540 ms (fullrate on 6 kbit/s) 780 ms (halfrate)	520 ms (fullrate on 14,5, 29,0 or 43,5 kbit/s) 480 ms (fullrate on 12 kbit/s) 540 ms (fullrate on 6 kbit/s) 780 ms (halfrate)
T2 (note 1)		< 80 ms (fullrate on 14,5, 29,0 or 43,5 kbit/s) < 80 ms (fullrate on 12 kbit/s) < 80 ms (fullrate on 6 kbit/s) < 80 ms (halfrate)	< 80 ms (fullrate on 14,5, 29,0 or 43,5 kbit/s) < 80 ms (fullrate on 12 kbit/s) < 80 ms (fullrate on 6 kbit/s) < 80 ms (halfrate)
N2	> 0	6	6
P _T	0	0	0
P ₀	0 – 3	0	3
P ₁	512 – 65535	512	2048
P ₂	6 – 250	6	20
T4 (note 1)	> 25 ms	30 ms 50 ms (fullrate on 14.5, 29.0 or 43.5 kbit/s)	30 ms 50 ms (fullrate on 14.5, 29.0 or 43.5 kbit/s)
Optional feature, Up signalling	0 – 1	0	1
<p>NOTE 1: The timer values shall fulfil the formula:</p> <ul style="list-style-type: none"> - T1 > T2 + T4 + (2 * transmission delay) for multi-link operation; - T1 > T2 + (2 * transmission delay) for single link operation. <p>For GSM the values apply according to indicated channel types, for UMTS the values apply according to "fullrate on 14.5". Timer T4 is ignored in UMTS and in single-link operation.</p> <p>NOTE 2: This value is recommended in the case of 4 physical links.</p> <p>NOTE 3: The maximum window size shall fulfil the formula:</p> <ul style="list-style-type: none"> - k_{max} < 496 - n * (1 + T4 / 20 ms), where n denotes the number of channels. <p>Any value k within the given range may be chosen.</p> <p>However, to avoid transmission delay the value k should be:</p> <ul style="list-style-type: none"> - k > n * (2 * transmission delay) / 20 ms. 			

3GPP N3 Meeting #12
Seattle, US, 28 August – 1 September 2000

Document N3-000441

e.g. for 3GPP use the format TP-99xxx
 or for SMG, use the format P-99-xxx

<h2 style="margin: 0;">CHANGE REQUEST</h2>		<i>Please see embedded help file at the bottom of this page for instructions on how to fill in this form correctly.</i>
27.001	CR	024r1
<small>GSM (AA.BB) or 3G (AA.BBB) specification number ↑</small>		<small>↑ CR number as allocated by MCC support team</small>
For submission to: CN#9 <small>list expected approval meeting # here ↑</small>		Current Version: 4.0.0
for approval <input checked="" type="checkbox"/> for information <input type="checkbox"/>		strategic <input type="checkbox"/> non-strategic <input type="checkbox"/> <small>(for SMG use only)</small>

Form: CR cover sheet, version 2 for 3GPP and SMG The latest version of this form is available from: <ftp://ftp.3gpp.org/Information/CR-Form-v2.doc>

Proposed change affects: (U)SIM ME UTRAN / Radio Core Network
(at least one should be marked with an X)

Source: TSG_N3 **Date:** 2000-07-04

Subject: UMTS clean-up

Work item: TEI

Category:	F Correction <input type="checkbox"/> A Corresponds to a correction in an earlier release <input checked="" type="checkbox"/> B Addition of feature <input type="checkbox"/> C Functional modification of feature <input type="checkbox"/> D Editorial modification <input type="checkbox"/>	Release:	Phase 2 <input type="checkbox"/> Release 96 <input type="checkbox"/> Release 97 <input type="checkbox"/> Release 98 <input type="checkbox"/> Release 99 <input type="checkbox"/> Release 00 <input checked="" type="checkbox"/>
------------------	----------------------------------------------------------------------------------------------------------------------------------------------------------------------------------------------------------------------------------------------------------------------------------------------------------	-----------------	------------------------------------------------------------------------------------------------------------------------------------------------------------------------------------------------------------------------------------------------

(only one category shall be marked with an X)

Reason for change:

- 1) The MS in the CALL CONFIRMED message may send extended BC-IE (containing octets 6d-6g) when no BC-IE is received. This change is needed in order to allow PSTN originated Mobile terminated calls in case of single numbering in UMTS.
- 2) H.223&H245 is also supported in GSM

Clauses affected: _____

Other specs affected:	Other 3G core specifications <input checked="" type="checkbox"/> Other GSM core specifications <input type="checkbox"/> MS test specifications <input type="checkbox"/> BSS test specifications <input type="checkbox"/> O&M specifications <input type="checkbox"/>	→ List of CRs: 27.001 R99 CR 030r1 → List of CRs: _____ → List of CRs: _____ → List of CRs: _____ → List of CRs: _____
------------------------------	----------------------------------------------------------------------------------------------------------------------------------------------------------------------------------------------------------------------------------------------------------------------------------	------------------------------------------------------------------------------------------------------------------------------------

Other comments: _____

8.3.3.1 Indication in case of Mobile terminating calls

In support of:

- PSTN originated calls; and
- ISDN originated calls using 3,1 kHz audio Bearer Capability (BC); as well as
- ISDN originated calls using unrestricted digital Bearer Capability but not specifying all parameters for deducing a Bearer Service.

Mobile specific requirements to be dealt with in the Bearer Capability information element the call confirmed message has been introduced in the call control protocol (3G TS 24.008). This also allows for renegotiation of specific parameters at the beginning of the connection set-up process. The specific parameters are:

- a) mobile specific requirements:
- Connection element (transparent/non transparent);
 - Structure (note 1);
 - Synchronous/Asynchronous (note 8);
 - Rate adaptation/other rate adaptation (note 9);
 - User information layer 2 protocol (note 1);
 - Intermediate rate (note 2), (note 3);
 - Modem Type (note 1), (note 3);
 - User Rate (note 3);
 - Compression ,
 - Fixed network user rate, (note 3) (note 4);
 - Other modem type, (note 3) (note 4);
 - User initiated modification indication (note 4).

The following parameters are indicated by the MS to the network, only:

- Acceptable channel codings (note 5);
- Maximum number of traffic channels, (note 5);
- Wanted air interface user rate (note 6) (note 7);
- Asymmetry preference indication (note 7).

NOTE 1: This parameter is correlated with the value of the parameter connection element.

NOTE 2: For non-transparent services this parameter is correlated with the value of the parameter negotiation of intermediate rate requested.

NOTE 3: Modification of these parameters may be proposed by the MS. The Network may accept it or not.

NOTE 4: This parameter shall be included by the MS only in case it was received from the network.

NOTE 5: This parameter shall be included only in case the parameter 'fixed network user rate' is included.

NOTE 6: This parameter shall be included only for non-transparent services and in case the parameter 'fixed network user rate' is included.

NOTE 7: This parameter has to be included if EDGE channel coding(s) are included in Acceptable channel codings. In cases where this parameter would not otherwise be included, the value is set to 'Air interface user rate not applicable' or 'User initiated modification not requested' or "No preference".

NOTE 8: For FTM and PIAFS, this parameter may be negotiated as in table B.4e. How the subscription for BS20 is assured, is an operator matter.

NOTE 9: For FTM, PIAFS or Multimedia, this parameter may be negotiated as in table B.4f.

b) requirements with effects at the partner terminal:

- Number of data bits;
- Number of stop bits;
- Parity.

The MS indicates the radio channel requirement in the call confirmed message. If the MS indicates the support of "dual" (HR and FR channels) the final decision, which radio channel is chosen, is done by the network in an RR message. The radio channel requirement is ignored in UMTS, see Table B.5a in Annex B.

If the network proposes optional support of both transparent and non transparent connection elements but does not indicate a user information layer 2 protocol, the MS shall set the appropriate value, if choosing non transparent in the call confirmed message and out-band flow control is not requested, see B.1.1.2.

Additionally the values of the parameters structure, modem type and intermediate rate have to be set in conformance with the values of the parameters radio channel requirements, negotiation of intermediate rate requested and connection element.

Subclause B.1.1.2 and table B.1 in the annex B describe the negotiation procedure. Annex B table B.4 describes the selection of the modem type and the dependence on the value of the parameter connection element. Annex B table B.4 describes the selection of the intermediate rate and user rate and their dependence upon the value of the NIRR parameter and the equipment capabilities.

The following MT cases can be deduced from the individual call set-up request conditions:

- a) If the set-up does not contain a BC information element, the MS in the call confirmed message shall include any BC information (single or multiple BC-IE). In case of multiple BC-IEs one BC-IE must indicate the information transfer capability "speech". A speech BC-IE together with a 3,1kHz multimedia BC-IE indicates the support of a fallback to speech (ref. to TS 29.007 and TS 24.008).
- b) If the set-up message contains a single BC-IE, the MS in the call confirm message shall use either a single BC-IE, if it wants to negotiate mobile specific parameter values, or, unless otherwise specified in annex B, no BC-IE, if it agrees with the requested ones.
- c) If the set-up contains a multiple BC-IE, the MS in the call confirmed message shall use either a multiple BC-IE, if it wants to negotiate mobile specific parameter values, or, unless otherwise specified in annex B, no BC-IE, if it agrees with the requested ones. In case of a 3,1kHz multimedia setup the MS can either accept the possibility of a fallback to speech by responding with two BC-IEs or with no BC-IEs or turn the call to a speech call by sending only a speech BC-IE in the call confirm message or turn the call to a multimedia only call (i.e. no fallback to speech allowed) by sending only a multimedia BC-IE in the call confirm message. Alternatively a single BC-IE containing fax group 3 only shall be used if a multiple BC-IE requesting speech alternate fax group 3 is received and the MS is not able to support the speech capability. Annex B, table B.7, describes the negotiation rules.

If the BC-IE contains 3,1 kHz ex PLMN, the MS is allowed to negotiate all mobile specific parameter values listed above. If the BC-IE contains facsimile group 3, the MS is allowed to negotiate the connection element (transparent/non transparent) only. In any case, if the set-up message requests a "single service", the MS must not answer in the call confirmed message requesting a "dual service" and vice versa.

However, for dual services with repeat indicator set to circular (alternate) the MS may change the sequence of dual BC-IEs within the call confirmed message (preceded by the same value of the repeat indicator), if it wants to start with a different Bearer Capability than proposed by the network as the initial one.

In addition, the MS may propose to the network to modify User Rate, Modem Type and Intermediate Rate in the CALL CONFIRMED message. The network may accept or release the call.

If the BC-IE received from the network contains the parameters 'fixed network user rate', 'other modem type' and possibly the 'user initiated modification', the MS can either:

- a) if in GSM, discard these parameters; or
- b) include the possibly modified values for the 'fixed network user rate' and 'other modem type' in the BC-IE of the call confirmed message. The network might accept or reject the modified values. In this case the MS shall also include the parameters 'maximum number of traffic channels' and 'acceptable channel codings'. Additionally for non-transparent services, the MS shall also include the parameters 'wanted air interface user rate' and the 'user initiated modification indication'.

In case a), The MS shall use the fall-back bearer service indicated by the remaining parameters of the BC-IE on a single slot configuration (reference GSM 04.21).

In GSM case b), a single slot configuration shall be used by the MS, in case the 'maximum number of traffic channels' is set to "1 TCH" and the 'user initiated modification indication' is set either to "user initiated modification not required" or to "user initiated modification up to 1TCH may be requested"; other wise the MS shall use a multislot configuration (reference GSM 04.21).

In case the 'acceptable channel codings' is indicated by the MS, the decision which channel coding is used is done by the network and indicated to the mobile station with an RR message. This RR message may also assign an asymmetric channel coding. The 'acceptable channel codings' parameter takes precedence over the 'negotiation of intermediate rate requested' parameter for non-transparent services. Also the intermediate rate and user rate per traffic channel in a multislot configuration are not indicated by the 'intermediate rate' and 'user rate' parameters of the BC-IE, but depend on the chosen channel coding only.

If the parameters 'fixed network user rate', 'other modem type' were not included in the BC-IE received, or no BC-IE was received, the MS shall not include these parameters in the CALL CONFIRMED message (i.e. octets 6d, 6e, 6f, and 6g ref. to 3G TS 24.008). If the MS receives a BC-IE in the SETUP message containing the parameters 'fixed network user rate', 'other modem type', the MS may include these parameters in the BC-IE of the CALL CONFIRMED message (i.e. octets 6d, 6e, 6f, and 6g ref. to 3G TS 24.008), with parameter values negotiated according to Annex B. If no BC-IE is received in the SETUP message, the MS may include these parameters in the CALL CONFIRMED message. However, in this case, the network may release the call if it does not support these parameters.

B.1.3.1.6 3G-H.324/M Case

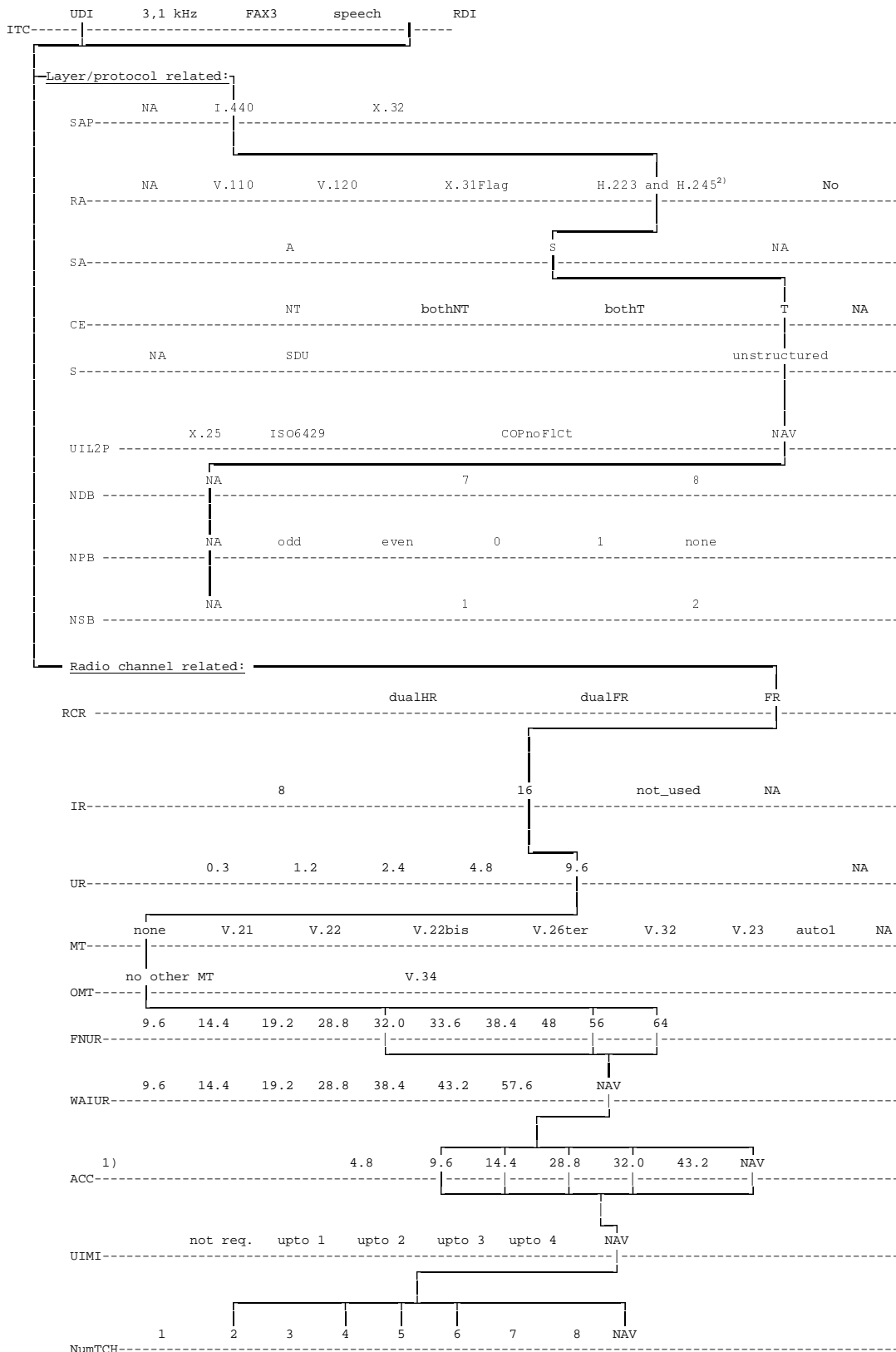

1) ACC may have several values simultaneously (bit map coding).

2) This value is interpreted as "No rate adaptation" in GSM.

B.1.3.2.3 3G-H.324/M Case

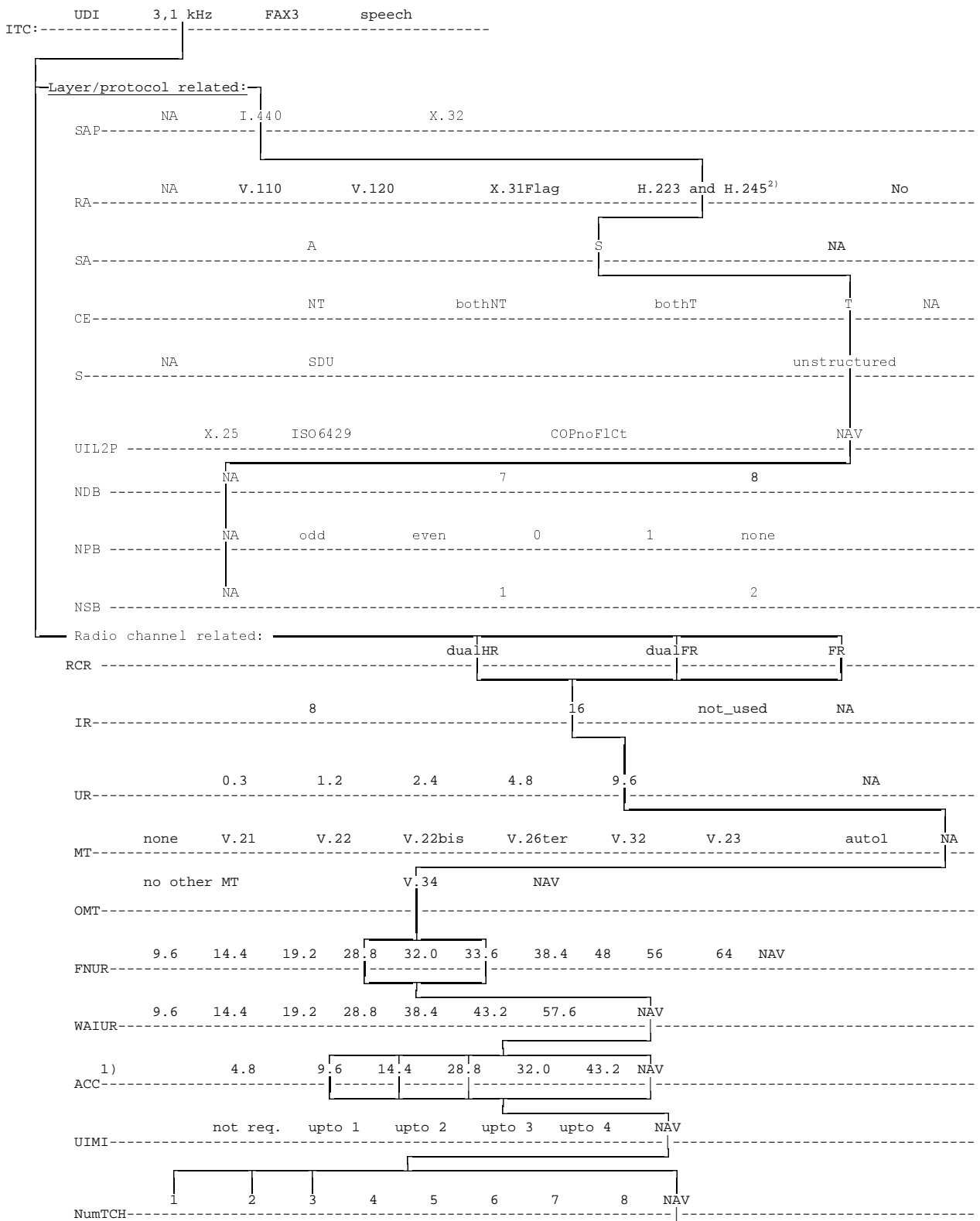

1) ACC may have several values simultaneously (bit map coding).

2) — This value is interpreted as "No rate adaptation" in GSM.

CHANGE REQUEST

Please see embedded help file at the bottom of this page for instructions on how to fill in this form correctly.

27.001 CR 025

Current Version: **3.5.0**

GSM (AA.BB) or 3G (AA.BBB) specification number ↑

↑ CR number as allocated by MCC support team

For submission to: **CN#9**
list expected approval meeting # here
↑

for approval
for information

strategic
non-strategic (for SMG use only)

Form: CR cover sheet, version 2 for 3GPP and SMG The latest version of this form is available from: <ftp://ftp.3gpp.org/Information/CR-Form-v2.doc>

Proposed change affects: (U)SIM ME UTRAN / Radio Core Network
(at least one should be marked with an X)

Source: TSG_N3 **Date:** 2000-07-04

Subject: Relevance of GSM specific BC-IE parameters for negotiating RLP version in UMTS

Work item: TEI

Category: F Correction
A Corresponds to a correction in an earlier release
B Addition of feature
C Functional modification of feature
D Editorial modification
(only one category shall be marked with an X)

Release: Phase 2
Release 96
Release 97
Release 98
Release 99
Release 00

Reason for change: Certain parameters in the BC-IE are specific to the GSM radio channel. These have no relevance for the UTRAN radio access bearer. However, in order to avoid renegotiating the RLP version during a call in case of handover to GSM, they may be used by the RLP entities to select the proper version to negotiate

Clauses affected: Annex A, B.1.1.2

Other specs affected:

Other 3G core specifications	<input checked="" type="checkbox"/>	→ List of CRs:	24.022CR005
Other GSM core specifications	<input type="checkbox"/>	→ List of CRs:	
MS test specifications	<input type="checkbox"/>	→ List of CRs:	
BSS test specifications	<input type="checkbox"/>	→ List of CRs:	
O&M specifications	<input type="checkbox"/>	→ List of CRs:	

Other comments:

Annex A (informative): List of Bearer Capability Elements

This annex lists the PLMN Bearer Capability Elements which need to be provided to support Terminal adaptation function to Interworking control procedures. Some parameters are ignored in UMTS although present in the BC-IE. The validity of parameter values may also differ from GSM to UMTS. The ignored parameters and the difference of parameter value ~~validity~~ validity in GSM and UMTS are listed in table B.5a in annex B.

Elements and their Values:

Information Transfer Capability:

This element is relevant between the IWF and the fixed network.

Values:

- Speech
- Unrestricted Digital
- Group 3 Facsimile (note 1)
- 3,1 kHz Ex PLMN (note 2)
- Restricted Digital (note 3)

NOTE 1: Used for facsimile transmission, unrestricted digital between MT and IWF and 3,1 kHz audio from IWF towards the fixed network.

NOTE 2: Unrestricted digital between MT and IWF and 3,1 kHz audio from IWF towards the fixed network.

NOTE 3: Unrestricted digital between MT and IWF and restricted digital information from IWF towards the fixed network; this value is signalled in the "Other ITC" element, due to a lack of further code points in the "ITC" element.

Transfer Mode:

This element is relevant between MT and IWF

Values:

- Circuit
- Packet

Structure:

This element is relevant between MT and IWF.

Values:

- Service Data Unit Integrity (note 4)
- Unstructured (note 5)

NOTE 4: Applicable for connection element "non transparent".

NOTE 5: Applicable for connection element "transparent".

Configuration:

This element is relevant for a PLMN connection.

Values:

- Point to point

Establishment:

This element is relevant for a PLMN connection.

Values:

- Demand

Sync/Async:

This element is relevant between TE/TA and MT and between IWF and the fixed network.

Values: - Synchronous
 - Asynchronous

Negotiation:

This element is relevant between MT and IWF.

Values: - In band negotiation not possible

User Rate:

This element is relevant between TE/TA and MT and between IWF and the fixed network, except in case the parameter FNUR is present.

Values: - 0.3 kbit/s
 - 1.2 kbit/s
 - 2.4 kbit/s
 - 4.8 kbit/s
 - 9.6 kbit/s
 - 19.2 kbit/s (see note 6)

NOTE 6: This value cannot be signalled between MT and IWF, but it can be used according to the rules in 3G TS 29.007 (table 7A, 7B) for such connections.

Intermediate Rate:

This element is relevant between MT and BSS and BSS and IWF

Values: - 8 kbit/s
 - 16 kbit/s

Network Independent Clock on Tx:

This element is relevant between TE/TA and MT in the transmit direction.

Values: - Not required
 - Required

Network Independent Clock on Rx:

This element is relevant between TE/TA and MT in the receive direction.

Values: - Not accepted
 - accepted

Number of Stop Bits:

This element is relevant between the TE/TA and MT and between IWF and fixed network in case of asynchronous transmission.

Values: - 1 bit
 - 2 bit

Number of Data Bits Excluding Parity If Present:

This element is relevant between TE/TA and MT and between IWF and the fixed network in case of a character oriented mode of transmission.

Values: - 7 bit
 - 8 bit

Parity Information:

This element is relevant between TE/TA and MT and between IWF and the fixed network for a character oriented mode of transmission.

- Values:
- Odd
 - Even
 - None
 - Forced to 0
 - Forced to 1

Duplex Mode:

This element is relevant between MT and IWF.

- Values:
- Full Duplex

Modem Type:

This element is relevant between the IWF and the fixed network in case of 3,1 kHz audio ex-PLMN information transfer capability.

- Values:
- V.21
 - V.22
 - V.22 bis
 - V.26 ter
 - V.32
 - autobauding type 1
 - none

Radio Channel Requirement:

This element is relevant between MT and BSS

- Values:
- Full Rate support only Mobile Station
 - Dual Rate support Mobile Station/Half Rate preferred
 - Dual Rate support Mobile Station/Full Rate preferred

Connection Element:

This element is relevant between MT and IWF

- Values:
- Transparent
 - Non Transparent
 - both, Transparent preferred
 - both, Non transparent preferred

User Information Layer 2 Protocol:

This element is relevant between TE/TA and MT and between IWF and the fixed network.

- Values:
- ISO 6429
 - X.25
 - X.75 layer 2 modified (CAPI)
 - Character oriented Protocol with no Flow Control mechanism

Signalling Access Protocol:

This element is relevant between TE/TA and MT.

- Values:
- I.440/450
 - X.32

Rate Adaptation:

This element is relevant between IWF and the fixed network.

- Values:
- V.110/X.30
 - X.31 flagstuffing
 - no rate adaptation
 - V.120 (note 7)
 - PIAFS (note 7)
 - H.223 and H.245 (note 7)

NOTE 7: This value is signalled in the "Other Rate Adaption" element, due to a lack of further code points in the "Rate Adaption" element.

Coding Standard:

This element refers to the structure of the BC-IE defined in 3G TS 24.008.

- Values:
- GSM

User Information Layer 1 Protocol:

This element characterizes the layer 1 protocol to be used between MT and BSS (Um interface) according to GSM 05.01, or between the MT and the RNC (Uu interface).

- Values:
- default

Negotiation of Intermediate Rate requested:

This element is relevant between MT and BSS and BSS and IWF.

- Values:
- no meaning associated
 - 6 kbit/s radio interface is requested for a full rate channel with a user rate up to and including 4,8 kbit/s, non transparent service

Compression:

This element is relevant between MT and IWF.

- Values:
- compression possible/allowed
 - compression not possible/allowed

Rate adaption header / no header:

This element is relevant between IWF and the fixed network. It is only applicable for V.120 rate adaptation.

- Values:
- Rate adaption header not included
 - Rate adaption header included

Multiple frame establishment support in data link:

This element is relevant between IWF and the fixed network. It is only applicable for V.120 rate adaptation.

- Values:
- Multiple frame establishment not supported. Only UI frames allowed.
 - Multiple frame establishment supported.

Mode of operation:

This element is relevant between IWF and the fixed network. It is only applicable for V.120 rate adaptation.

- Values:
- Bit transparent mode of operation
 - Protocol sensitive mode of operation

Logical link identifier negotiation:

This element is relevant between IWF and the fixed network. It is only applicable for V.120 rate adaptation.

Values: - Default, LLI=256 only
 - Full protocol negotiation (note 8)

NOTE 8: A connection over which protocol negotiation will be executed is indicated in the „In-band / out-band negotiation" parameter.

Assignor / assignee:

This element is relevant between IWF and the fixed network. It is only applicable for V.120 rate adaptation.

Values: - Message originator is „default assignee"
 - Message originator is „assignor only"

In-band / out-band negotiation:

This element is relevant between IWF and the fixed network. It is only applicable for V.120 rate adaptation.

Values: - Negotiation is done with USER INFORMATION messages on a temporary signalling connection
 - Negotiation is done in-band using logical link zero.

Fixed network user rate, FNUR (Note 12)

This element is relevant between the IWF and the fixed network.

Values - Fixed network user rate not applicable (note 9)
 - 9,6 kbit/s
 - 14,4 kbit/s
 - 19,2 kbit/s
 - 28,8 kbit/s
 - 32,0 kbit/s
 - 38,4 kbit/s
 - 48,0 kbit/s
 - 56,0 kbit/s
 - 64,0 kbit/s

NOTE 9: Not used by currently specified services.

Wanted air interface user rate, WAIUR (note 12)

This element is relevant between the MT and the IWF

Values - Air interface user rate not applicable
 - 9,6 kbit/s
 - 14,4 kbit/s
 - 19,2 kbit/s
 - 28,8 kbit/s
 - 38,4 kbit/s
 - 43,2 kbit/s
 - 57,6 kbit/s
 - interpreted by the network as 38,4 kbit/s (note 10)

NOTE 10: Certain code points, if used, will be interpreted by the network as 38.4 kbit/s in this version of the protocol, ref TS 24.008.

Acceptable channel codings, ACC (note 12)

This element is relevant between the MT and the IWF.

- Value:
- TCH/F4.8 acceptable
 - TCH/F9.6 acceptable
 - TCH/F14.4 acceptable
 - TCH/F28.8 acceptable
 - TCH/F32.0 acceptable (Applicable to bit transparent 56 and 64 kbit/s services only)
 - TCH/F43.2 acceptable (Applicable to non-transparent services only.)

Maximum number of traffic channels, MaxNumTCH (Note 12)

This element is relevant between the MT and the IWF.

- Value:
- 1 TCH
 - 2 TCH
 - 3 TCH
 - 4 TCH
 - 5 TCH
 - 6 TCH
 - 7 TCH (note 11)
 - 8 TCH (note 11)

NOTE11: Not used by currently specified services.

Other modem type, OMT (Note 12)

This element is relevant between the IWF and the fixed network in case of 3,1 kHz audio ex-PLMN

- Values:
- no other modem type specified in this field
 - V.34

User initiated modification indication, UIMI (Note 12)

This element is relevant between the MT and the IWF.

- Values:
- user initiated modification not requested
 - user initiated modification upto 1 TCH requested
 - user initiated modification upto 2 TCH requested
 - user initiated modification upto 3 TCH requested
 - user initiated modification upto 4 TCH requested

Asymmetry preference indication (Note 12)

This element is relevant between the MT and the BSS.

- Value:
- no preference
 - up link biased asymmetry preference
 - down link biased asymmetry preference

NOTE 12: These GBS-related parameters are optional.

For a multislot configuration, the following applies to the parameters contained in the BC-IE:

- Half rate channels are not supported. The MS shall code the radio channel requirement as "Full rate support only MS" or "Dual rate support MS, full rate preferred". In the second case, the network shall assign full rate channel(s) only.
- The 'fixed network user rate' and 'other modem type' (ref. table B.4a) takes precedence over the 'user rate' and 'modem type'.
- The ACC indicates which channel coding is acceptable and supported by the MS. In case of CE:NT the TCH/F4.8 and TCH/F9.6 acceptable is equivalent to the support of NIRR. If TCH/F4.8 acceptable only or TCH/F9.6 acceptable only or TCH/F14.4 acceptable only is indicated, the assigned channel type which can be chosen by the network is TCH/F4.8 or TCH/F9.6 or TCH/F14.4, respectively.

- The 'intermediate rate' parameter is overridden. The intermediate rate used per each TCH/F is derived from the chosen channel type:

channel type	IR per TCH/F
TCH/F4.8	8 kbit/s
TCH/F9.6	16 kbit/s
TCH/F14.4	intermediate rate is to be defined

- The user rate per TCH is derived from the chosen channel type:

channel type	user rate per TCH
TCH/F4.8	4.8 kbit/s
TCH/F9.6	9.6 kbit/s

For CE:T, the padding procedure described in GSM 04.21 can be applied.

B.1.1.2 Interpretation of the Diagrams

The purpose of the subsequent diagrams is to achieve unambiguous representation of the individual contents of the PLMN BC-IE for the various occurrences during the call set-up phase, covering all bearer services and teleservices according to 3G TS 22.002 and 3G TS 22.003.

The basic principle adopted is a graphic scheme, or mask, wherein the ordinate designates the individual parameters of the PLMN BC-IE and the abscissa gives the possible field values of these parameters. The abbreviations used in these sections are defined in table B.5. The allowed content of any PLMN BC-IE is represented by a number of graphs connecting parameter values (abscissa points) of all parameters (ordinate points). Each graphic scheme is subdivided into two independent parts:

- "Layer/Protocol related" part; and
- "Radio Channel related" part.

The generation of all PLMN BC-IEs in all call set-up messages shall be in accordance with these graphs. Subclauses B.1.2 through B.1.11 show individual sets of graphs for each service group (BS/TS) and for each type of applicable Information Transfer Capability.

In addition, the following rules apply:

- Those parameters which have only one possible field value for all recognized services are shown in table B.5, where they are marked accordingly in the column "common setting of field values". They are not represented in the graphic scheme.
- Not all parameters of the PLMN BC-IE are relevant for each service (BS/TS). This is represented by specific abscissa points with a value of "NA" (Not Applicable) allocated to these parameters. The graphs pass through these points for each such parameter. The actual field value to be used in the PLMN BC-IE is marked in the column "default setting of field values (NA)" of table B.5. An abscissa point with a value of "NAV" (Not Available) indicates that the entire octet carrying this parameter (ref. table B.2 "General Structure of the PLMN BC-Information Element") shall be omitted.
- Unless FTM is applied, there is a particular dependency of the parameters "User Information Layer 2 Protocol (UIL2P)" and "Connection Element (CE)":
 - If the MS sends a PLMN BC-IE with a CE value other than "Transparent (T)", the parameter UIL2P is essential. Its field value must be set as indicated in the applicable graph.
 - If the MSC sends a PLMN BC-IE in the SETUP message, the parameter UIL2P may also be absent in the case of the CE parameter value being other than "Transparent (T)".
- In case FTM is applied, the PLMN BC-IE shows a CE value "non-transparent", SA value "asynchronous", and RA value X.31 flag stuffing. The UIL2P is not available.
- Certain parameters of the PLMN BC-IE may be negotiated during the connection establishment phase. Table B.1 shows these parameters and the relations of their values in the SETUP message and in the CALL CONFIRMED/CALL PROCEEDING message, respectively, both for the mobile-originated and mobile-terminated case. A parameter may indicate a field value of one of the following types:
 - "requested value" indicating a request which cannot be changed by the responding entity;
 - "offered value" indicating a proposal which may be changed by the responding entity;
 - a particular choice value leaving it up to the responding entity which value ultimately applies;
 - "as requested" indicating that the requested value applies and is confirmed (by returning it);
 - "selected value" indicating that a particular value applies either out of the offered set or as a free choice out of the defined set of values;
 - "supported value" indicating a value supported by the responding entity.

Table B.1: BC-Parameters subject to negotiation procedure

Mobile Originated Call:

BC-parameter	Message	
	SETUP	CALL PROC
NDB	Requested value	as requested
NPB	Requested value	as requested
NSB	Requested value	as requested
CE	Requested value (T/NT)	as requested
	"both" with the preferred value indicated (e.g. both NT)	selected value (T/NT)
UIL2P	Requested value ⁹⁾ or NAV ¹⁾	as requested or NAV ⁴⁾
User Rate	Requested value	as requested
DC	Requested value ²⁾	as requested or "NO" ⁷⁾
FNUR	Requested value	supported value
Other MT	Requested value	supported value
UIMI	Requested value	supported value

Mobile Terminated Call:

BC-parameter	Message	
	SETUP	CALL CONF
NDB	Offered value	selected value (free choice)
NPB	offered value	selected value (free choice)
NSB	offered value	selected value (free choice)
CE	requested value (T/NT)	as requested or selected value (T/NT) (free choice) ³⁾
	"both" with the preferred value indicated (e.g. both NT)	selected value (T/NT)
Sync/ Asynchronous	requested value	as requested or selected value ¹⁰⁾
Rate adaptation/Other rate adaptation	requested value	as requested or selected value ¹¹⁾
UIL2P	offered value ²⁾ or NAV ⁴⁾	selected or NAV ¹⁾
User Rate	offered value	selected value ⁵⁾
DC	requested value ²⁾	as requested or "NO" ⁷⁾
FNUR	offered value	selected value ⁶⁾
Other MT	offered value	selected value ⁶⁾
UIMI	offered value	selected value ⁸⁾

- 1) For CE:T only, out-band flow control, or RA:X.31 flag stuffing requested by the MS.
- 2) Not for CE:T.
- 3) When the SETUP message contains no BC-IE (single numbering scheme).
- 4) "NAV" shall not be interpreted as an out-band flow control request by the MS.
- 5) The modification of User Rate must be in conjunction with Modem Type and Intermediate Rate.
- 6) The modification of the Fixed Network User Rate shall be in conjunction with the Modem Type and/or Other Modem Type.
- 7) In case of a Mobile Terminated Call, if the SETUP message does not contain a BC-IE, the MS shall behave as if the DC is set to "data compression not possible".
In case of a MO CALL or a MT CALL where no BC-IE is included in the CALL PROCEEDING or CALL CONFIRMED message, respectively, the MS or the network shall behave as if the DC was set to "data compression not possible" or "data compression not allowed", respectively.
- 8) Less or equal to the offered value.
- 9) Not for CT:T or FTM (i.e., CE:NT, SA:A, RA:X.31 flag stuffing).
- 10) For FTM and PIAFS, this parameter may be negotiated. See Table B.4e for details.
- 11) For FTM, PIAFS and Multimedia, this parameter may be negotiated. See Table B.4f for details.

Table B.2: General Structure of the BC-Information Element

OCTET	INFORMATION ELEMENT FIELD
3	Radio channel requirements Coding standard Transfer mode Information Transfer Capability
4	Structure 2) Duplex mode Configuration Establishment Negotiation of Intermediate Rate Requested Compression
5	Rate adaption 2) Signalling access protocol
5a	Other ITC 2) 7) Other rate adaption
5b	Rate adaption header / no header 2) 3) Multiple frame establishment support in data link Mode of operation Logical link identifier negotiation Assignor / assignee In-band / out-band negotiation
6	User information layer 1 protocol 2) Synchronous / asynchronous
6a	Number of stop bits 2) Negotiation Number of data bits User rate
6b	Intermediate rate 2) NIC on transmission NIC on reception Parity information
6c	Connection element 2) Modem type
6d	Fixed network user rate 4) Other modem type
6e	Maximum number of traffic channels 4) Acceptable channel codings
6f	Wanted air interface user rate 4) User initiated modification indication
6g	Acceptable Channel codings 5) Asymmetry preference indication 6)
7	User information layer 2 protocol 1) 2)
1)	Octets optional.
2)	Octets only available if the parameter "Information Transfer Capability" does not indicate "Speech".
3)	For V.120 rate adaption only.
4)	Optional octets available only if the parameter "Information Transfer Capability" does not indicate "Speech".
5)	Extension of the 'Acceptable channel codings' field in octet 6e in case EDGE channel codings are supported.
6)	Only used if EDGE channels are among the 'Acceptable channel codings'. The value shall be set to 'no preference' in case the connection element is T.
7)	For ITC=RDI or UIL1P=V.120, PIAFS, and 'H.223 and H.245' only.

Table B.3a: Selection of flow control method (for CE:NT with SA:A only)

information element	flow control method		
	in-band	out-band (3)	none
number of data bits	7 or 8	7 or 8	7 or 8
user information layer 2 protocol	ISO 6429 (1)	NAV	COPnoFICt (2)
1)	ISO6429 stands for "ISO 6429, codeset 0, DC1/DC3" and is applicable for 7 and 8 bit codes.		
2)	COPnoFICt stands for a character oriented protocol with no flow control mechanism (no reserved characters for flow control).		
3)	<p>"out-band" flow control requires V.42 in case of PSTN or V.110 in case of ISDN.</p> <p>If the V.110 flow control mechanism is not supported, where required, the call pending shall be terminated.</p> <p>If the V.42 functionality is not supported by the modem in the IWF or in the fixed network, the call will be supported with a fallback to the non-V.42 mode. In this case the IWF will release the call if due to temporary throughput problems on the radio interface or initiation of flow control by the MS and the inability to flow control the fixed network modem an overflow of the L2R buffers occurs.</p> <p>Note that a phase 1 network may release the call, if the V.42 functionality is not provided by the IWF or the fixed network modem. As V.42 does not apply to V.21 modems, outband flow control can not be supported for these modem types.</p>		

Table B.3b: Selection of PLMN Profile (for CE:NT with SA:S only)

Mobile Terminated Call:

BC-parameter	Message SETUP	Message CALL CONF
UIL2P	X.25	X.25 or X.75

Table B.4a: Modem Type subject to negotiation procedure

Mobile Originated Call:

BC-parameter CE	BC-parameter MT and OMT ⁶⁾	
	Message SETUP	Message CALL PROC
T	V-series	V-series
NT	V-series	V-series
	autobauding type 1	autobauding type 1 or V-series ¹⁾
bothT or bothNT	V-series	V-series
	autobauding type 1	autobauding type 1 or V-series ¹⁾²⁾

Mobile Terminated Call:

BC-parameter CE	BC-parameter MT and OMT ⁶⁾	
	Message SETUP	Message CALL CONF
T	V-series	V-series
NT	V-series	V-series or autobauding type ¹³⁾
	autobauding type 1	autobauding type 1 or V-series ⁴⁾
bothT or bothNT	V-series	V-series
	autobauding type 1	autobauding type 1 or V-series ⁴⁾⁵⁾

- 1) No autobauding capability in the IWF:MSC.
- 2) CE:T selected by IWF/MSC.
- 3) Free choice if the SETUP contains no BC-IE (single numbering scheme).
If the IWF/MSC has no autobauding capability, a V-series modem type is used.
- 4) When the MS does not allow the use of autobauding capability.
- 5) CE:T selected by the MS.
- 6) When the MT indicates "autobauding", "modem for undefined interface" or "none", the OMT shall be set to "no other modem type". Any other values of the MT is overridden by the OMT value.

Table B.4b: Intermediate Rate negotiation procedure

If the user rate is 9.6 kbit/s the intermediate rate negotiation procedure is not applicable and NIRR shall be set to "No meaning".

Recipient of SETUP supports full rate, non transparent, 6 kbit/s radio interface rate and the user rate is up to/equal 4,8 kbit/s:

BC-parameter	Message SETUP	Message CALL CONF or CALL PROC
NIRR	6 kbit/s	6 kbit/s
IR	16 kbit/s	8 kbit/s
User Rate	up to/equal 4,8 kbit/s	as requested

NOTE 1: In case of a Mobile Terminated Call, if the SETUP message does not contain a BC-IE, the MS shall behave as if NIRR set to "No meaning".

In case of a MO CALL or a MT CALL where no BC-IE is included in the CALL PROCEEDING or CALL CONFIRMED message, respectively, the MS or the network shall behave as if the NIRR was set to "No meaning".

Recipient of SETUP does support full rate, non transparent, but not in connection with 6 kbit/s radio interface rate:

BC-parameter	Message SETUP	Message CALL CONF or CALL PROC
NIRR	6 kbit/s	No meaning
IR	16 kbit/s	16 kbit/s
User Rate	up to/equal 4,8 kbit/s	as requested

NOTE 2: If no other parameter needs negotiation, the CALL CONF/PROC message need not contain any BC-IE.

In case of a MO CALL or a MT CALL where no BC-IE is included in the CALL PROCEEDING or CALL CONFIRMED message, respectively, the MS or the network shall behave as if the NIRR was set to "No meaning".

NOTE 3: In case a GBS-operation is requested and acknowledged, the MS indicates the acceptable channel codings. The indicated acceptance of TCH/F4.8 is equivalent to the support of 6 kbit/s radio interface rate per TCH/F and therefore overrides the NIRR parameter.

Table B.4c Negotiation of fixed network user rate

BC-parameter	Message SETUP	Message CALL PROC/CONFIRMED
FNUR	requested value	equal or lower than the requested value

The network might accept the modified value or reject the call. The FNUR negotiation is applicable in case of a HSCSD-operation, only.

Table B.4d Negotiation of user initiated modification indication

BC-parameter	Message SETUP	Message CALL PROC/CONFIRMED
UIMI	offered value	equal to or a value indicating a request for modification to a lower number of traffic channels than offered

Table B.4e: Negotiation of Synchronous/Asynchronous

Mobile Terminated Call:

BC-parameter Synchronous/Asynchronous		
Bearer type	Message SETUP	Message CALL CONF
FTM ¹⁾	Synchronous	Asynchronous
PIAFS ²⁾	Synchronous	Asynchronous

- 1) This negotiation is possible, only if ITC=UDI or RDI, FNUR=64 or 56 kbit/s and CE=NT or "both" is signalled in the SETUP message. The MS shall signal FTM as specified in B.1.2.3 .
- 2) This negotiation is possible, only if ITC=UDI, FNUR=32 kbit/s and CE= "both" is signalled in the SETUP message. The UE shall signal PIAFS as specified in B.1.2.4

Table B.4f: Negotiation of Rate adaptation/Other rate adaptation

Mobile Terminated Call:

Bearer type	BC-parameter Rate adaptation/Other rate adaptation	
	Message SETUP	Message CALL CONF
FTM ¹⁾	V.110, I.460 and X.30	X.31 flag stuffing
PIAFS ²⁾	V.110, I.460 and X.30	PIAFS
Multimedia	V.110, I.460 and X.30 ³⁾	H.223 and H.245
	No rate adaptation ⁵⁾	H.223 and H.245

- 1) This negotiation is possible, only if ITC=UDI or RDI, FNUR=64 or 56 kbit/s and CE=NT or "both" is signalled in the SETUP message. The MS shall signal FTM as specified in B.1.2.3.
- 2) This negotiation is possible, only if ITC=UDI, FNUR=32 kbit/s and CE= "both" is signalled in the SETUP message. The UE shall signal PIAFS as specified in B.1.2.4.
- 3) This negotiation is possible, only if ITC=UDI or RDI, FNUR=32 or 56 kbit/s and CE=T or "both" is signalled in the SETUP message. The MS shall signal 3G-H.324/M as specified in B.1.3.1.6.
- 5) This negotiation is possible, only if ITC=3,1 kHz, FNUR=28.8 kbit/s, MT=V.34 and CE=T or "both" is signalled in the SETUP message. The MS shall signal 3G-H.324/M as specified in B.1.3.2.3.

Table B.5: BC parameter setting (part 1)

Abbreviations for Parameters and Values:		common setting of field values	
		default setting of field values (NA)	
ITC...Information Transfer Capability:	<ul style="list-style-type: none"> - Speech - UDI..Unrestricted Digital - FAX3..Group 3 Facsimile - 3,1 kHz..3,1 kHz Ex PLMN - RDI..Restricted Digital 	v	v
TM....Transfer Mode:	<ul style="list-style-type: none"> - ci..Circuit 	X	X
S.....Structure:	<ul style="list-style-type: none"> - SDU..Service Data Unit Integrity - Unstructured 	X	
C.....Configuration:	<ul style="list-style-type: none"> - pp..Point to point 	X	X
E.....Establishment:	<ul style="list-style-type: none"> - de..Demand 	X	X
SA....Sync/Async:	<ul style="list-style-type: none"> - S..Synchronous - A..Asynchronous 		
N.....Negotiation	<ul style="list-style-type: none"> - ibn..in band negotiation not possible 	X	X
UR....User Rate:	<ul style="list-style-type: none"> - 0.3..0.3 kbit/s - 1.2..1.2 kbit/s - 2.4..2.4 kbit/s - 4.8..4.8 kbit/s - 9.6..9.6 kbit/s 		
IR....Intermediate Rate:	<ul style="list-style-type: none"> - 4.. 4 kbit/s - 8.. 8 kbit/s - 16.. 16 kbit/s - not_used..not used 	X	
NICT..Network Independent Clock on Tx:	<ul style="list-style-type: none"> - not_required.. Not required - required 	X	X
NICR..Network Independent Clock on Rx:	<ul style="list-style-type: none"> - not_accepted..not accepted - accepted 	X	X
NSB...Number of Stop Bits:	<ul style="list-style-type: none"> - 1..1 bit - 2..2 bit 	X	
NDB...Number of Data Bits Excluding Parity If Present:	<ul style="list-style-type: none"> - 7.. 7 bit - 8.. 8 bit 	X	
NPB...Parity Information:	<ul style="list-style-type: none"> - Odd - Even - None - 0.. Forced to 0 - 1.. Forced to 1 	X	
UIL1P.User Information Layer 1 Protocol	<ul style="list-style-type: none"> - def..default layer 1 protocol 	X	X

Table B.5: BC parameter setting (part 2)

Abbreviations for Parameters and Values	common setting of field values	
	default setting of field values (NA)	
DM...Duplex Mode:	- - fd.. Full Duplex	X X
MT...Modem Type:	- V.21 - V.22 - V.22 bis - V.26 ter - V.32 - autol.. autobaoding type 1 - none	X
RCR...Radio Channel Requirement:	- FR Full Rate support only Mobile Station - dual HR Dual Rate support Mobile Station/ Half Rate preferred - dual FR Dual Rate support Mobile Station/ Full Rate preferred	
CE...Connection Element:	- T.. Transparent - NT.. Non Transparent - bothT both transparent preferred - bothNT both non Transparent preferred	
UIL2P.User Information Layer 2 Protocol:	- ISO6429..ISO6429, codeset 0, DC1/DC3 - X.25 - X.75..X.75 layer 2 modified (CAPI) - COPnoFlCt..Character oriented protocol with no flow control mechanism	
SAP...Signalling Access Protocol:	- I.440.. I.440/450 - X.32	X
RA...Rate Adaptation:	- V.110.. V.110/X.30 - X.31Flag.. X.31 flagstuffing - NO.. no rate adaptation - V.120 - PIAFS - H.223 and H.245	X
CS...Coding Standard:	- GSM	X X
NIRR..Negotiation of Intermediate Rate Requested:	NM..No Meaning associated with this value 6kbit/s..6kbit/s radio interface rate requested	X
DC...Data Compression	- DC.. compression possible/allowed - NO.. compression not possible/allowed	

Table B.5: BC parameter setting (part 3)

Abbreviations for Parameters and Values	common setting of field values	
	default setting of field values (NA)	
FNUR...Fixed Network User Rate	<ul style="list-style-type: none"> - FNUR not applicable - 9.6.. 9.6 kbit/s - 14.4.. 14.4 kbit/s - 19.2.. 19.2 kbit/s - 28.8.. 28.8 kbit/s - 32.0.. 32.0 kbit/s - 33.6.. 33.6 kbit/s - 38.4.. 38.4 kbit/s - 48.0.. 48.0 kbit/s - 56.0.. 56.0 kbit/s - 64.0.. 64.0 kbit/s 	
WAIUR...Wanted Air Interface User Rate	<ul style="list-style-type: none"> - WAIUR not applicable - 9.6.. 9.6 kbit/s - 14.4.. 14.4 kbit/s - 19.2.. 19.2 kbit/s - 28.8.. 28.8 kbit/s - 38.4.. 38.4 kbit/s - 43.2.. 43.2 kbit/s - 57.6.. 57.6 kbit/s - int 38.4.. interpreted by the network as 38.4 kbit/s 	
ACC.....Acceptable channel codings	<ul style="list-style-type: none"> - 4.8.. TCH/F4.8 acceptable - 9.6.. TCH/F9.6 acceptable - 14.4..TCH/F14.4 acceptable - 28.8..TCH/F28.8 acceptable - 32.0..TCH/F32.0 acceptable - 43.2..TCH/F28.8 acceptable - none..No channel coding (defined by selecting none of the above 	
MaxNumTCH...Maximum Number of Traffic Channels	<ul style="list-style-type: none"> - 1.. 1 TCH - 2.. 2 TCH - 3.. 3 TCH - 4.. 4 TCH - 5.. 5 TCH - 6.. 6 TCH - 7.. 7 TCH - 8.. 8 TCH 	
OMT...Other modem type	<ul style="list-style-type: none"> - no other MT.. no other modem type - V.34.. V.34 	
User initiated modification indication	<ul style="list-style-type: none"> - not req.. user initiated modification not required - upto 1 TCH.. user initiated modification upto 1 TCH may be requested - upto 2 TCH.. user initiated modification upto 2 TCH may be requested - upto 3 TCH.. user initiated modification upto 3 TCH may be requested - upto 4 TCH.. user initiated modification upto 4 TCH may be requested 	
Asymmetry preference indication	<ul style="list-style-type: none"> - 00 no preference - 01 up link biased asymmetry preferred - 10 down link biased asymmetry preferred 	

Table B.5a: Differences in parameter value validity in GSM and UMTS

Parameter / value	GSM	UMTS
Radio Channel Requirements / any	valid	ignored
User rate / any	valid	ignored
Intermediate Rate / any	valid	ignored
NIC on transmission / any	valid	ignored
NIC on reception / any	valid	ignored
Negotiation of IR requested / any	valid	ignored
Acceptable Channel Codings / any	valid	Ignored (note 1)
Maximum number of traffic channels / any	valid	Ignored (note 1)
User initiated modification indication / any	valid	ignored
Asymmetry preference indication/ any	valid	ignored
Modem type /		
V.21, V.22, V.22bis, V.26ter	valid	Invalid
V.32	valid	invalid for CE=T
Fixed Network User Rate /		
32, 33.6 kbit/s	invalid	valid
9.6, 14.4, 19.2, 38.4	valid	invalid for CE=T
48.0	valid	invalid
Other Rate adaptation /		
H.223 and H.245	valid	valid
PIAFS	invalid	valid

NOTE: Although a parameter value is marked as "valid", the validity may be restricted by rules given elsewhere in the present document.

NOTE 1: This parameter is relevant in UMTS for NT calls for deciding which RLP version to negotiate in order to avoid renegotiation of RLP version in case of handover, see 3G TS 24.022 [9]. It is otherwise irrelevant for specifying the UTRAN radio access bearer..

Table B.6: Channel combinations

Single Bearer and Teleservices

MS indication BC	Network selection CT
FR dual FR dual HR	FR FR or HR HR or FR

Alternate services

MS indication		Network selection				
BC(1)	BC(2)	CT(1)	CT(2)	Or	CT(1)	CT(2)
FR	FR	FR	FR			
FR	dual Rate	FR	FR			
dual Rate	dual Rate	FR	FR	Or	HR	HR
dual Rate	FR	FR	FR			

Followed-by services

MS indication		Network selection							
BC(1)	BC(2)	CT(1)	CT(2)	or	CT(1)	CT(2)	or	CT(1)	CT(2)
FR	FR	FR	FR						
FR	dual Rate	FR	FR						
dual Rate	dual Rate	FR	FR	or	HR	HR	or	FR	HR
dual Rate	FR	FR	FR						

BC Bearer Capability
 CT Channel Type
 dual Rate {dual FR | dual HR}

Table B.7: TS61/TS62 Negotiation rules

Mobile Originating Call

Subscription	SETUP	CALL PROCEED
TS61	TS61 s/f TS61 f/s	TS61 s/f or TS62 TS61 f/s or TS62
	TS62	TS62
TS62	TS61 s/f TS61 f/s	TS62 TS62
	TS62	TS62

Mobile Terminating Call

Subscription	SETUP	CALL CONFIRMED
TS61	TS61 s/f	TS61 s/f or TS61 f/s or TS62
	TS61 f/s	TS61 s/f or TS61 f/s or TS62
	TS62	TS62
	no BC	TS61 s/f or TS61 f/s or TS62
TS62	TS62	TS62
	no BC	TS62 (note)

s/f = speech then fax
 f/s = fax then speech

NOTE: TS61 is also accepted if the VMSC supports TS61 and does not perform subscription checking on a CALL CONFIRMED message (see GSM 02.01 and 3G TS 29.007).

CHANGE REQUEST

Please see embedded help file at the bottom of this page for instructions on how to fill in this form correctly.

27.001 CR 028

Current Version: **4.0.0**

GSM (AA.BB) or 3G (AA.BBB) specification number ↑

↑ CR number as allocated by MCC support team

For submission to: **CN#9**
list expected approval meeting # here ↑

for approval
for information

strategic
non-strategic (for SMG use only)

Form: CR cover sheet, version 2 for 3GPP and SMG The latest version of this form is available from: <ftp://ftp.3gpp.org/Information/CR-Form-v2.doc>

Proposed change affects: (U)SIM ME UTRAN / Radio Core Network
(at least one should be marked with an X)

Source: TSG_N3. **Date:** 2000-07-11

Subject: Relevance of GSM specific BC-IE parameters for negotiating RLP version in UMTS

Work item: TEI

Category: (only one category shall be marked with an X)	F Correction	<input type="checkbox"/>	Release:	Phase 2	<input type="checkbox"/>
	A Corresponds to a correction in an earlier release	<input checked="" type="checkbox"/>		Release 96	<input type="checkbox"/>
	B Addition of feature	<input type="checkbox"/>		Release 97	<input type="checkbox"/>
	C Functional modification of feature	<input type="checkbox"/>		Release 98	<input type="checkbox"/>
	D Editorial modification	<input type="checkbox"/>		Release 99	<input type="checkbox"/>
			Release 00	<input checked="" type="checkbox"/>	

Reason for change: Certain parameters in the BC-IE are specific to the GSM radio channel. These have no relevance for the UTRAN radio access bearer. However, in order to avoid renegotiating the RLP version during a call in case of handover to GSM, they may be used by the RLP entities to select the proper version to negotiate

Clauses affected: Annex A, B.1.1.2

Other specs affected:	Other 3G core specifications	<input checked="" type="checkbox"/>	→ List of CRs:	24.022CR 005
	Other GSM core specifications	<input type="checkbox"/>	→ List of CRs:	
	MS test specifications	<input type="checkbox"/>	→ List of CRs:	
	BSS test specifications	<input type="checkbox"/>	→ List of CRs:	
	O&M specifications	<input type="checkbox"/>	→ List of CRs:	

Other comments:

Annex A (informative): List of Bearer Capability Elements

This annex lists the PLMN Bearer Capability Elements which need to be provided to support Terminal adaptation function to Interworking control procedures. Some parameters are ignored in UMTS although present in the BC-IE. The validity of parameter values may also differ from GSM to UMTS. The ignored parameters and the difference of parameter value ~~validity~~ validity in GSM and UMTS are listed in table B.5a in annex B.

Elements and their Values:

Information Transfer Capability:

This element is relevant between the IWF and the fixed network.

Values:

- Speech
- Unrestricted Digital
- Group 3 Facsimile (note 1)
- 3,1 kHz Ex PLMN (note 2)
- Restricted Digital (note 3)

NOTE 1: Used for facsimile transmission, unrestricted digital between MT and IWF and 3,1 kHz audio from IWF towards the fixed network.

NOTE 2: Unrestricted digital between MT and IWF and 3,1 kHz audio from IWF towards the fixed network.

NOTE 3: Unrestricted digital between MT and IWF and restricted digital information from IWF towards the fixed network; this value is signalled in the "Other ITC" element, due to a lack of further code points in the "ITC" element.

Transfer Mode:

This element is relevant between MT and IWF

Values:

- Circuit
- Packet

Structure:

This element is relevant between MT and IWF.

Values:

- Service Data Unit Integrity (note 4)
- Unstructured (note 5)

NOTE 4: Applicable for connection element "non transparent".

NOTE 5: Applicable for connection element "transparent".

Configuration:

This element is relevant for a PLMN connection.

Values:

- Point to point

Establishment:

This element is relevant for a PLMN connection.

Values:

- Demand

Sync/Async:

This element is relevant between TE/TA and MT and between IWF and the fixed network.

Values: - Synchronous
 - Asynchronous

Negotiation:

This element is relevant between MT and IWF.

Values: - In band negotiation not possible

User Rate:

This element is relevant between TE/TA and MT and between IWF and the fixed network, except in case the parameter FNUR is present.

Values: - 0.3 kbit/s
 - 1.2 kbit/s
 - 2.4 kbit/s
 - 4.8 kbit/s
 - 9.6 kbit/s
 - 19.2 kbit/s (see note 6)

NOTE 6: This value cannot be signalled between MT and IWF, but it can be used according to the rules in 3G TS 29.007 (table 7A, 7B) for such connections.

Intermediate Rate:

This element is relevant between MT and BSS and BSS and IWF

Values: - 8 kbit/s
 - 16 kbit/s

Network Independent Clock on Tx:

This element is relevant between TE/TA and MT in the transmit direction.

Values: - Not required
 - Required

Network Independent Clock on Rx:

This element is relevant between TE/TA and MT in the receive direction.

Values: - Not accepted
 - accepted

Number of Stop Bits:

This element is relevant between the TE/TA and MT and between IWF and fixed network in case of asynchronous transmission.

Values: - 1 bit
 - 2 bit

Number of Data Bits Excluding Parity If Present:

This element is relevant between TE/TA and MT and between IWF and the fixed network in case of a character oriented mode of transmission.

Values: - 7 bit
 - 8 bit

Parity Information:

This element is relevant between TE/TA and MT and between IWF and the fixed network for a character oriented mode of transmission.

- Values:
- Odd
 - Even
 - None
 - Forced to 0
 - Forced to 1

Duplex Mode:

This element is relevant between MT and IWF.

- Values:
- Full Duplex

Modem Type:

This element is relevant between the IWF and the fixed network in case of 3,1 kHz audio ex-PLMN information transfer capability.

- Values:
- V.21
 - V.22
 - V.22 bis
 - V.26 ter
 - V.32
 - autobauding type 1
 - none

Radio Channel Requirement:

This element is relevant between MT and BSS

- Values:
- Full Rate support only Mobile Station
 - Dual Rate support Mobile Station/Half Rate preferred
 - Dual Rate support Mobile Station/Full Rate preferred

Connection Element:

This element is relevant between MT and IWF

- Values:
- Transparent
 - Non Transparent
 - both, Transparent preferred
 - both, Non transparent preferred

User Information Layer 2 Protocol:

This element is relevant between TE/TA and MT and between IWF and the fixed network.

- Values:
- ISO 6429
 - X.25
 - X.75 layer 2 modified (CAPI)
 - Character oriented Protocol with no Flow Control mechanism

Signalling Access Protocol:

This element is relevant between TE/TA and MT.

- Values:
- I.440/450
 - X.32

Rate Adaptation:

This element is relevant between IWF and the fixed network.

Values:

- V.110/X.30
- X.31 flagstuffing
- no rate adaptation
- V.120 (note 7)
- PIAFS (note 7)
- H.223 and H.245 (note 7)

NOTE 7: This value is signalled in the "Other Rate Adaption" element, due to a lack of further code points in the "Rate Adaption" element.

Coding Standard:

This element refers to the structure of the BC-IE defined in 3G TS 24.008.

Values: - GSM

User Information Layer 1 Protocol:

This element characterizes the layer 1 protocol to be used between MT and BSS (Um interface) according to GSM 05.01, or between the MT and the RNC (Uu interface).

Values: - default

Negotiation of Intermediate Rate requested:

This element is relevant between MT and BSS and BSS and IWF.

Values:

- no meaning associated
- 6 kbit/s radio interface is requested for a full rate channel with a user rate up to and including 4,8 kbit/s, non transparent service

Compression:

This element is relevant between MT and IWF.

Values:

- compression possible/allowed
- compression not possible/allowed

Rate adaption header / no header:

This element is relevant between IWF and the fixed network. It is only applicable for V.120 rate adaptation.

Values:

- Rate adaption header not included
- Rate adaption header included

Multiple frame establishment support in data link:

This element is relevant between IWF and the fixed network. It is only applicable for V.120 rate adaptation.

Values:

- Multiple frame establishment not supported. Only UI frames allowed.
- Multiple frame establishment supported.

Mode of operation:

This element is relevant between IWF and the fixed network. It is only applicable for V.120 rate adaptation.

Values:

- Bit transparent mode of operation
- Protocol sensitive mode of operation

Logical link identifier negotiation:

This element is relevant between IWF and the fixed network. It is only applicable for V.120 rate adaptation.

Values: - Default, LLI=256 only
 - Full protocol negotiation (note 8)

NOTE 8: A connection over which protocol negotiation will be executed is indicated in the „In-band / out-band negotiation" parameter.

Assignor / assignee:

This element is relevant between IWF and the fixed network. It is only applicable for V.120 rate adaptation.

Values: - Message originator is „default assignee"
 - Message originator is „assignor only"

In-band / out-band negotiation:

This element is relevant between IWF and the fixed network. It is only applicable for V.120 rate adaptation.

Values: - Negotiation is done with USER INFORMATION messages on a temporary signalling connection
 - Negotiation is done in-band using logical link zero.

Fixed network user rate, FNUR (Note 12)

This element is relevant between the IWF and the fixed network.

Values - Fixed network user rate not applicable (note 9)
 - 9,6 kbit/s
 - 14,4 kbit/s
 - 19,2 kbit/s
 - 28,8 kbit/s
 - 32,0 kbit/s
 - 38,4 kbit/s
 - 48,0 kbit/s
 - 56,0 kbit/s
 - 64,0 kbit/s

NOTE 9: Not used by currently specified services.

Wanted air interface user rate, WAIUR (note 12)

This element is relevant between the MT and the IWF

Values - Air interface user rate not applicable
 - 9,6 kbit/s
 - 14,4 kbit/s
 - 19,2 kbit/s
 - 28,8 kbit/s
 - 38,4 kbit/s
 - 43,2 kbit/s
 - 57,6 kbit/s
 - interpreted by the network as 38,4 kbit/s (note 10)

NOTE 10: Certain code points, if used, will be interpreted by the network as 38.4 kbit/s in this version of the protocol, ref TS 24.008.

Acceptable channel codings, ACC (note 12)

This element is relevant between the MT and the IWF.

- Value:
- TCH/F4.8 acceptable
 - TCH/F9.6 acceptable
 - TCH/F14.4 acceptable
 - TCH/F28.8 acceptable
 - TCH/F32.0 acceptable (Applicable to bit transparent 56 and 64 kbit/s services only)
 - TCH/F43.2 acceptable (Applicable to non-transparent services only.)

Maximum number of traffic channels, MaxNumTCH (Note 12)

This element is relevant between the MT and the IWF.

- Value:
- 1 TCH
 - 2 TCH
 - 3 TCH
 - 4 TCH
 - 5 TCH
 - 6 TCH
 - 7 TCH (note 11)
 - 8 TCH (note 11)

NOTE11: Not used by currently specified services.

Other modem type, OMT (Note 12)

This element is relevant between the IWF and the fixed network in case of 3,1 kHz audio ex-PLMN

- Values:
- no other modem type specified in this field
 - V.34

User initiated modification indication, UIMI (Note 12)

This element is relevant between the MT and the IWF.

- Values:
- user initiated modification not requested
 - user initiated modification upto 1 TCH requested
 - user initiated modification upto 2 TCH requested
 - user initiated modification upto 3 TCH requested
 - user initiated modification upto 4 TCH requested

Asymmetry preference indication (Note 12)

This element is relevant between the MT and the BSS.

- Value:
- no preference
 - up link biased asymmetry preference
 - down link biased asymmetry preference

NOTE 12: These GBS-related parameters are optional.

For a multislot configuration, the following applies to the parameters contained in the BC-IE:

- Half rate channels are not supported. The MS shall code the radio channel requirement as "Full rate support only MS" or "Dual rate support MS, full rate preferred". In the second case, the network shall assign full rate channel(s) only.
- The 'fixed network user rate' and 'other modem type' (ref. table B.4a) takes precedence over the 'user rate' and 'modem type'.
- The ACC indicates which channel coding is acceptable and supported by the MS. In case of CE:NT the TCH/F4.8 and TCH/F9.6 acceptable is equivalent to the support of NIRR. If TCH/F4.8 acceptable only or TCH/F9.6 acceptable only or TCH/F14.4 acceptable only is indicated, the assigned channel type which can be chosen by the network is TCH/F4.8 or TCH/F9.6 or TCH/F14.4, respectively.

- The 'intermediate rate' parameter is overridden. The intermediate rate used per each TCH/F is derived from the chosen channel type:

channel type	IR per TCH/F
TCH/F4.8	8 kbit/s
TCH/F9.6	16 kbit/s
TCH/F14.4	intermediate rate is to be defined

- The user rate per TCH is derived from the chosen channel type:

channel type	user rate per TCH
TCH/F4.8	4.8 kbit/s
TCH/F9.6	9.6 kbit/s

For CE:T, the padding procedure described in GSM 04.21 can be applied.

B.1.1.2 Interpretation of the Diagrams

The purpose of the subsequent diagrams is to achieve unambiguous representation of the individual contents of the PLMN BC-IE for the various occurrences during the call set-up phase, covering all bearer services and teleservices according to 3G TS 22.002 and 3G TS 22.003.

The basic principle adopted is a graphic scheme, or mask, wherein the ordinate designates the individual parameters of the PLMN BC-IE and the abscissa gives the possible field values of these parameters. The abbreviations used in these sections are defined in table B.5. The allowed content of any PLMN BC-IE is represented by a number of graphs connecting parameter values (abscissa points) of all parameters (ordinate points). Each graphic scheme is subdivided into two independent parts:

- "Layer/Protocol related" part; and
- "Radio Channel related" part.

The generation of all PLMN BC-IEs in all call set-up messages shall be in accordance with these graphs. Subclauses B.1.2 through B.1.11 show individual sets of graphs for each service group (BS/TS) and for each type of applicable Information Transfer Capability.

In addition, the following rules apply:

- Those parameters which have only one possible field value for all recognized services are shown in table B.5, where they are marked accordingly in the column "common setting of field values". They are not represented in the graphic scheme.
- Not all parameters of the PLMN BC-IE are relevant for each service (BS/TS). This is represented by specific abscissa points with a value of "NA" (Not Applicable) allocated to these parameters. The graphs pass through these points for each such parameter. The actual field value to be used in the PLMN BC-IE is marked in the column "default setting of field values (NA)" of table B.5. An abscissa point with a value of "NAV" (Not Available) indicates that the entire octet carrying this parameter (ref. table B.2 "General Structure of the PLMN BC-Information Element") shall be omitted.
- Unless FTM is applied, there is a particular dependency of the parameters "User Information Layer 2 Protocol (UIL2P)" and "Connection Element (CE)":
 - If the MS sends a PLMN BC-IE with a CE value other than "Transparent (T)", the parameter UIL2P is essential. Its field value must be set as indicated in the applicable graph.
 - If the MSC sends a PLMN BC-IE in the SETUP message, the parameter UIL2P may also be absent in the case of the CE parameter value being other than "Transparent (T)".
- In case FTM is applied, the PLMN BC-IE shows a CE value "non-transparent", SA value "asynchronous", and RA value X.31 flag stuffing. The UIL2P is not available.
- Certain parameters of the PLMN BC-IE may be negotiated during the connection establishment phase. Table B.1 shows these parameters and the relations of their values in the SETUP message and in the CALL CONFIRMED/CALL PROCEEDING message, respectively, both for the mobile-originated and mobile-terminated case. A parameter may indicate a field value of one of the following types:
 - "requested value" indicating a request which cannot be changed by the responding entity;
 - "offered value" indicating a proposal which may be changed by the responding entity;
 - a particular choice value leaving it up to the responding entity which value ultimately applies;
 - "as requested" indicating that the requested value applies and is confirmed (by returning it);
 - "selected value" indicating that a particular value applies either out of the offered set or as a free choice out of the defined set of values;
 - "supported value" indicating a value supported by the responding entity.

Table B.1: BC-Parameters subject to negotiation procedure

Mobile Originated Call:

BC-parameter	Message	
	SETUP	CALL PROC
NDB	Requested value	as requested
NPB	Requested value	as requested
NSB	Requested value	as requested
CE	Requested value (T/NT)	as requested
	"both" with the preferred value indicated (e.g. both NT)	selected value (T/NT)
UIL2P	Requested value ⁹⁾ or NAV ¹⁾	as requested or NAV ⁴⁾
User Rate	Requested value	as requested
DC	Requested value ²⁾	as requested or "NO" ⁷⁾
FNUR	Requested value	supported value
Other MT	Requested value	supported value
UIMI	Requested value	supported value

Mobile Terminated Call:

BC-parameter	Message	
	SETUP	CALL CONF
NDB	Offered value	selected value (free choice)
NPB	offered value	selected value (free choice)
NSB	offered value	selected value (free choice)
CE	requested value (T/NT)	as requested or selected value (T/NT) (free choice) ³⁾
	"both" with the preferred value indicated (e.g. both NT)	selected value (T/NT)
Sync/ Asynchronous	requested value	as requested or selected value ¹⁰⁾
Rate adaptation/Other rate adaptation	requested value	as requested or selected value ¹¹⁾
UIL2P	offered value ²⁾ or NAV ⁴⁾	selected or NAV ¹⁾
User Rate	offered value	selected value ⁵⁾
DC	requested value ²⁾	as requested or "NO" ⁷⁾
FNUR	offered value	selected value ⁶⁾
Other MT	offered value	selected value ⁶⁾
UIMI	offered value	selected value ⁸⁾

- 1) For CE:T only, out-band flow control, or RA:X.31 flag stuffing requested by the MS.
- 2) Not for CE:T.
- 3) When the SETUP message contains no BC-IE (single numbering scheme).
- 4) "NAV" shall not be interpreted as an out-band flow control request by the MS.
- 5) The modification of User Rate must be in conjunction with Modem Type and Intermediate Rate.
- 6) The modification of the Fixed Network User Rate shall be in conjunction with the Modem Type and/or Other Modem Type.
- 7) In case of a Mobile Terminated Call, if the SETUP message does not contain a BC-IE, the MS shall behave as if the DC is set to "data compression not possible".
In case of a MO CALL or a MT CALL where no BC-IE is included in the CALL PROCEEDING or CALL CONFIRMED message, respectively, the MS or the network shall behave as if the DC was set to "data compression not possible" or "data compression not allowed", respectively.
- 8) Less or equal to the offered value.
- 9) Not for CT:T or FTM (i.e., CE:NT, SA:A, RA:X.31 flag stuffing).
- 10) For FTM and PIAFS, this parameter may be negotiated. See Table B.4e for details.
- 11) For FTM, PIAFS and Multimedia, this parameter may be negotiated. See Table B.4f for details.

Table B.2: General Structure of the BC-Information Element

OCTET	INFORMATION ELEMENT FIELD
3	Radio channel requirements Coding standard Transfer mode Information Transfer Capability
4	Structure 2) Duplex mode Configuration Establishment Negotiation of Intermediate Rate Requested Compression
5	Rate adaption 2) Signalling access protocol
5a	Other ITC 2) 7) Other rate adaption
5b	Rate adaption header / no header 2) 3) Multiple frame establishment support in data link Mode of operation Logical link identifier negotiation Assignor / assignee In-band / out-band negotiation
6	User information layer 1 protocol 2) Synchronous / asynchronous
6a	Number of stop bits 2) Negotiation Number of data bits User rate
6b	Intermediate rate 2) NIC on transmission NIC on reception Parity information
6c	Connection element 2) Modem type
6d	Fixed network user rate 4) Other modem type
6e	Maximum number of traffic channels 4) Acceptable channel codings
6f	Wanted air interface user rate 4) User initiated modification indication
6g	Acceptable Channel codings 5) Asymmetry preference indication 6)
7	User information layer 2 protocol 1) 2)
1)	Octets optional.
2)	Octets only available if the parameter "Information Transfer Capability" does not indicate "Speech".
3)	For V.120 rate adaption only.
4)	Optional octets available only if the parameter "Information Transfer Capability" does not indicate "Speech".
5)	Extension of the 'Acceptable channel codings' field in octet 6e in case EDGE channel codings are supported.
6)	Only used if EDGE channels are among the 'Acceptable channel codings'. The value shall be set to 'no preference' in case the connection element is T.
7)	For ITC=RDI or UIL1P=V.120, PIAFS, and 'H.223 and H.245' only.

Table B.3a: Selection of flow control method (for CE:NT with SA:A only)

information element	flow control method		
	in-band	out-band (3)	none
number of data bits	7 or 8	7 or 8	7 or 8
user information layer 2 protocol	ISO 6429 (1)	NAV	COPnoFICt (2)
1)	ISO6429 stands for "ISO 6429, codeset 0, DC1/DC3" and is applicable for 7 and 8 bit codes.		
2)	COPnoFICt stands for a character oriented protocol with no flow control mechanism (no reserved characters for flow control).		
3)	<p>"out-band" flow control requires V.42 in case of PSTN or V.110 in case of ISDN.</p> <p>If the V.110 flow control mechanism is not supported, where required, the call pending shall be terminated.</p> <p>If the V.42 functionality is not supported by the modem in the IWF or in the fixed network, the call will be supported with a fallback to the non-V.42 mode. In this case the IWF will release the call if due to temporary throughput problems on the radio interface or initiation of flow control by the MS and the inability to flow control the fixed network modem an overflow of the L2R buffers occurs.</p> <p>Note that a phase 1 network may release the call, if the V.42 functionality is not provided by the IWF or the fixed network modem. As V.42 does not apply to V.21 modems, outband flow control can not be supported for these modem types.</p>		

Table B.3b: Selection of PLMN Profile (for CE:NT with SA:S only)

Mobile Terminated Call:

BC-parameter	Message SETUP	Message CALL CONF
UIL2P	X.25	X.25 or X.75

Table B.4a: Modem Type subject to negotiation procedure

Mobile Originated Call:

BC-parameter CE	BC-parameter MT and OMT ⁶⁾	
	Message SETUP	Message CALL PROC
T	V-series	V-series
NT	V-series	V-series
	autobauding type 1	autobauding type 1 or V-series ¹⁾
bothT or bothNT	V-series	V-series
	autobauding type 1	autobauding type 1 or V-series ¹⁾²⁾

Mobile Terminated Call:

BC-parameter CE	BC-parameter MT and OMT ⁶⁾	
	Message SETUP	Message CALL CONF
T	V-series	V-series
NT	V-series	V-series or autobauding type ¹³⁾
	autobauding type 1	autobauding type 1 or V-series ⁴⁾
bothT or bothNT	V-series	V-series
	autobauding type 1	autobauding type 1 or V-series ⁴⁾⁵⁾

- 1) No autobauding capability in the IWF:MSC.
- 2) CE:T selected by IWF/MSC.
- 3) Free choice if the SETUP contains no BC-IE (single numbering scheme).
If the IWF/MSC has no autobauding capability, a V-series modem type is used.
- 4) When the MS does not allow the use of autobauding capability.
- 5) CE:T selected by the MS.
- 6) When the MT indicates "autobauding", "modem for undefined interface" or "none", the OMT shall be set to "no other modem type". Any other values of the MT is overridden by the OMT value.

Table B.4b: Intermediate Rate negotiation procedure

If the user rate is 9.6 kbit/s the intermediate rate negotiation procedure is not applicable and NIRR shall be set to "No meaning".

Recipient of SETUP supports full rate, non transparent, 6 kbit/s radio interface rate and the user rate is up to/equal 4,8 kbit/s:

BC-parameter	Message SETUP	Message CALL CONF or CALL PROC
NIRR	6 kbit/s	6 kbit/s
IR	16 kbit/s	8 kbit/s
User Rate	up to/equal 4,8 kbit/s	as requested

NOTE 1: In case of a Mobile Terminated Call, if the SETUP message does not contain a BC-IE, the MS shall behave as if NIRR set to "No meaning".

In case of a MO CALL or a MT CALL where no BC-IE is included in the CALL PROCEEDING or CALL CONFIRMED message, respectively, the MS or the network shall behave as if the NIRR was set to "No meaning".

Recipient of SETUP does support full rate, non transparent, but not in connection with 6 kbit/s radio interface rate:

BC-parameter	Message SETUP	Message CALL CONF or CALL PROC
NIRR	6 kbit/s	No meaning
IR	16 kbit/s	16 kbit/s
User Rate	up to/equal 4,8 kbit/s	as requested

NOTE 2: If no other parameter needs negotiation, the CALL CONF/PROC message need not contain any BC-IE.

In case of a MO CALL or a MT CALL where no BC-IE is included in the CALL PROCEEDING or CALL CONFIRMED message, respectively, the MS or the network shall behave as if the NIRR was set to "No meaning".

NOTE 3: In case a GBS-operation is requested and acknowledged, the MS indicates the acceptable channel codings. The indicated acceptance of TCH/F4.8 is equivalent to the support of 6 kbit/s radio interface rate per TCH/F and therefore overrides the NIRR parameter.

Table B.4c Negotiation of fixed network user rate

BC-parameter	Message SETUP	Message CALL PROC/CONFIRMED
FNUR	requested value	equal or lower than the requested value

The network might accept the modified value or reject the call. The FNUR negotiation is applicable in case of a HSCSD-operation, only.

Table B.4d Negotiation of user initiated modification indication

BC-parameter	Message SETUP	Message CALL PROC/CONFIRMED
UIMI	offered value	equal to or a value indicating a request for modification to a lower number of traffic channels than offered

Table B.4e: Negotiation of Synchronous/Asynchronous

Mobile Terminated Call:

BC-parameter Synchronous/Asynchronous		
Bearer type	Message SETUP	Message CALL CONF
FTM ¹⁾	Synchronous	Asynchronous
PIAFS ²⁾	Synchronous	Asynchronous

- 1) This negotiation is possible, only if ITC=UDI or RDI, FNUR=64 or 56 kbit/s and CE=NT or "both" is signalled in the SETUP message. The MS shall signal FTM as specified in B.1.2.3 .
- 2) This negotiation is possible, only if ITC=UDI, FNUR=32 kbit/s and CE= "both" is signalled in the SETUP message. The UE shall signal PIAFS as specified in B.1.2.4

Table B.4f: Negotiation of Rate adaptation/Other rate adaptation

Mobile Terminated Call:

Bearer type	BC-parameter Rate adaptation/Other rate adaptation	
	Message SETUP	Message CALL CONF
FTM ¹⁾	V.110, I.460 and X.30	X.31 flag stuffing
PIAFS ²⁾	V.110, I.460 and X.30	PIAFS
Multimedia	V.110, I.460 and X.30 ³⁾	H.223 and H.245
	No rate adaptation ⁵⁾	H.223 and H.245

- 1) This negotiation is possible, only if ITC=UDI or RDI, FNUR=64 or 56 kbit/s and CE=NT or "both" is signalled in the SETUP message. The MS shall signal FTM as specified in B.1.2.3.
- 2) This negotiation is possible, only if ITC=UDI, FNUR=32 kbit/s and CE= "both" is signalled in the SETUP message. The UE shall signal PIAFS as specified in B.1.2.4.
- 3) This negotiation is possible, only if ITC=UDI or RDI, FNUR=32 or 56 kbit/s and CE=T or "both" is signalled in the SETUP message. The MS shall signal 3G-H.324/M as specified in B.1.3.1.6.
- 5) This negotiation is possible, only if ITC=3,1 kHz, FNUR=28.8 kbit/s, MT=V.34 and CE=T or "both" is signalled in the SETUP message. The MS shall signal 3G-H.324/M as specified in B.1.3.2.3.

Table B.5: BC parameter setting (part 1)

Abbreviations for Parameters and Values:		common setting of field values		
		default setting of field values (NA)	v	v
ITC...Information Transfer Capability:	- Speech - UDI..Unrestricted Digital - FAX3..Group 3 Facsimile - 3,1 kHz..3,1 kHz Ex PLMN - RDI..Restricted Digital			
TM....Transfer Mode:	- ci..Circuit		X	X
S.....Structure:	- SDU..Service Data Unit Integrity - Unstructured		X	
C.....Configuration:	- pp..Point to point		X	X
E.....Establishment:	- de..Demand		X	X
SA....Sync/Async:	- S..Synchronous - A..Asynchronous			
N.....Negotiation	- ibn..in band negotiation not possible		X	X
UR....User Rate:	- 0.3..0.3 kbit/s - 1.2..1.2 kbit/s - 2.4..2.4 kbit/s - 4.8..4.8 kbit/s - 9.6..9.6 kbit/s			
IR....Intermediate Rate:	- 4.. 4 kbit/s - 8.. 8 kbit/s - 16.. 16 kbit/s - not_used..not used		X	
NICT..Network Independent Clock on Tx:	- not_required.. Not required - required		X	X
NICR..Network Independent Clock on Rx:	- not_accepted..not accepted - accepted		X	X
NSB...Number of Stop Bits:	- 1..1 bit - 2..2 bit		X	
NDB...Number of Data Bits Excluding Parity If Present:	- 7.. 7 bit - 8.. 8 bit		X	
NPB...Parity Information:	- Odd - Even - None - 0.. Forced to 0 - 1.. Forced to 1		X	
UIL1P.User Information Layer 1 Protocol	- def..default layer 1 protocol		X	X

Table B.5: BC parameter setting (part 2)

Abbreviations for Parameters and Values	common setting of field values	
	default setting of field values (NA)	
DM...Duplex Mode:	- - fd.. Full Duplex	X X
MT...Modem Type:	- V.21 - V.22 - V.22 bis - V.26 ter - V.32 - autol.. autobauding type 1 - none	X
RCR...Radio Channel Requirement:	- FR Full Rate support only Mobile Station - dual HR Dual Rate support Mobile Station/ Half Rate preferred - dual FR Dual Rate support Mobile Station/ Full Rate preferred	
CE...Connection Element:	- T.. Transparent - NT.. Non Transparent - bothT both transparent preferred - bothNT both non Transparent preferred	
UIL2P.User Information Layer 2 Protocol:	- ISO6429..ISO6429, codeset 0, DC1/DC3 - X.25 - X.75..X.75 layer 2 modified (CAPI) - COPnoFlCt..Character oriented protocol with no flow control mechanism	
SAP...Signalling Access Protocol:	- I.440.. I.440/450 - X.32	X
RA...Rate Adaptation:	- V.110.. V.110/X.30 - X.31Flag.. X.31 flagstuffing - NO.. no rate adaptation - V.120 - PIAFS - H.223 and H.245	X
CS...Coding Standard:	- GSM	X X
NIRR..Negotiation of Intermediate Rate Requested:	NM..No Meaning associated with this value 6kbit/s..6kbit/s radio interface rate requested	X
DC...Data Compression	- DC.. compression possible/allowed - NO.. compression not possible/allowed	

Table B.5: BC parameter setting (part 3)

Abbreviations for Parameters and Values	common setting of field values		
	default setting of field values (NA)	V	V
FNUR...Fixed Network User Rate	<ul style="list-style-type: none"> - FNUR not applicable - 9.6.. 9.6 kbit/s - 14.4.. 14.4 kbit/s - 19.2.. 19.2 kbit/s - 28.8.. 28.8 kbit/s - 32.0.. 32.0 kbit/s - 33.6.. 33.6 kbit/s - 38.4.. 38.4 kbit/s - 48.0.. 48.0 kbit/s - 56.0.. 56.0 kbit/s - 64.0.. 64.0 kbit/s 		
WAIUR...Wanted Air Interface User Rate	<ul style="list-style-type: none"> - WAIUR not applicable - 9.6.. 9.6 kbit/s - 14.4.. 14.4 kbit/s - 19.2.. 19.2 kbit/s - 28.8.. 28.8 kbit/s - 38.4.. 38.4 kbit/s - 43.2.. 43.2 kbit/s - 57.6.. 57.6 kbit/s - int 38.4.. interpreted by the network as 38.4 kbit/s 		
ACC.....Acceptable channel codings	<ul style="list-style-type: none"> - 4.8.. TCH/F4.8 acceptable - 9.6.. TCH/F9.6 acceptable - 14.4..TCH/F14.4 acceptable - 28.8..TCH/F28.8 acceptable - 32.0..TCH/F32.0 acceptable - 43.2..TCH/F28.8 acceptable - none..No channel coding (defined by selecting none of the above 		
MaxNumTCH...Maximum Number of Traffic Channels	<ul style="list-style-type: none"> - 1.. 1 TCH - 2.. 2 TCH - 3.. 3 TCH - 4.. 4 TCH - 5.. 5 TCH - 6.. 6 TCH - 7.. 7 TCH - 8.. 8 TCH 		
OMT...Other modem type	<ul style="list-style-type: none"> - no other MT.. no other modem type - V.34.. V.34 		
User initiated modification indication	<ul style="list-style-type: none"> - not req.. user initiated modification not required - upto 1 TCH.. user initiated modification upto 1 TCH may be requested - upto 2 TCH.. user initiated modification upto 2 TCH may be requested - upto 3 TCH.. user initiated modification upto 3 TCH may be requested - upto 4 TCH.. user initiated modification upto 4 TCH may be requested 		
Asymmetry preference indication	<ul style="list-style-type: none"> - 00 no preference - 01 up link biased asymmetry preferred - 10 down link biased asymmetry preferred 		

Table B.5a: Differences in parameter value validity in GSM and UMTS

Parameter / value	GSM	UMTS
Radio Channel Requirements / any	valid	ignored
User rate / any	valid	ignored
Intermediate Rate / any	valid	ignored
NIC on transmission / any	valid	ignored
NIC on reception / any	valid	ignored
Negotiation of IR requested / any	valid	ignored
Acceptable Channel Codings / any	valid	Ignored (note 1)
Maximum number of traffic channels / any	valid	Ignored (note 1)
User initiated modification indication / any	valid	ignored
Asymmetry preference indication/ any	valid	ignored
Modem type /		
V.21, V.22, V.22bis, V.26ter	valid	Invalid
V.32	valid	invalid for CE=T
Fixed Network User Rate /		
32, 33.6 kbit/s	invalid	valid
9.6, 14.4, 19.2, 38.4	valid	invalid for CE=T
48.0	valid	invalid
Other Rate adaptation /		
H.223 and H.245	valid	valid
PIAFS	invalid	valid

NOTE: Although a parameter value is marked as "valid", the validity may be restricted by rules given elsewhere in the present document.

NOTE 1: This parameter is relevant in UMTS for NT calls for deciding which RLP version to negotiate in order to avoid renegotiation of RLP version in case of handover, see 3G TS 24.022 [9]. It is otherwise irrelevant for specifying the UTRAN radio access bearer..

Table B.6: Channel combinations

Single Bearer and Teleservices

MS indication BC	Network selection CT
FR dual FR dual HR	FR FR or HR HR or FR

Alternate services

MS indication		Network selection				
BC(1)	BC(2)	CT(1)	CT(2)	Or	CT(1)	CT(2)
FR	FR	FR	FR			
FR	dual Rate	FR	FR			
dual Rate	dual Rate	FR	FR	Or	HR	HR
dual Rate	FR	FR	FR			

Followed-by services

MS indication		Network selection							
BC(1)	BC(2)	CT(1)	CT(2)	or	CT(1)	CT(2)	or	CT(1)	CT(2)
FR	FR	FR	FR						
FR	dual Rate	FR	FR						
dual Rate	dual Rate	FR	FR	or	HR	HR	or	FR	HR
dual Rate	FR	FR	FR						

BC Bearer Capability
 CT Channel Type
 dual Rate {dual FR | dual HR}

Table B.7: TS61/TS62 Negotiation rules

Mobile Originating Call

Subscription	SETUP	CALL PROCEED
TS61	TS61 s/f TS61 f/s	TS61 s/f or TS62 TS61 f/s or TS62
	TS62	TS62
TS62	TS61 s/f	TS62
	TS61 f/s	TS62
	TS62	TS62

Mobile Terminating Call

Subscription	SETUP	CALL CONFIRMED
TS61	TS61 s/f	TS61 s/f or TS61 f/s or TS62
	TS61 f/s	TS61 s/f or TS61 f/s or TS62
	TS62	TS62
	no BC	TS61 s/f or TS61 f/s or TS62
TS62	TS62	TS62
	no BC	TS62 (note)

s/f = speech then fax
 f/s = fax then speech

NOTE: TS61 is also accepted if the VMSC supports TS61 and does not perform subscription checking on a CALL CONFIRMED message (see GSM 02.01 and 3G TS 29.007).

3GPP N3 Meeting #12
Seattle, US, 28 August – 1 September 2000

Document **N3-000440**

e.g. for 3GPP use the format TP-99xxx
or for SMG, use the format P-99-xxx

CHANGE REQUEST

Please see embedded help file at the bottom of this page for instructions on how to fill in this form correctly.

27.001 CR 030r1

Current Version: **3.5.0**

GSM (AA.BB) or 3G (AA.BBB) specification number ↑

↑ CR number as allocated by MCC support team

For submission to: **CN#9**
list expected approval meeting # here
↑

for approval
for information

strategic
non-strategic (for SMG use only)

Form: CR cover sheet, version 2 for 3GPP and SMG The latest version of this form is available from: <ftp://ftp.3gpp.org/Information/CR-Form-v2.doc>

Proposed change affects: (U)SIM ME UTRAN / Radio Core Network
(at least one should be marked with an X)

Source: TSG_N3 **Date:** 2000-08-25

Subject: UMTS clean-up

Work item: TEI

Category: <i>(only one category shall be marked with an X)</i>	F Correction	<input checked="" type="checkbox"/>	Release:	Phase 2	<input type="checkbox"/>
	A Corresponds to a correction in an earlier release	<input type="checkbox"/>		Release 96	<input type="checkbox"/>
	B Addition of feature	<input type="checkbox"/>		Release 97	<input type="checkbox"/>
	C Functional modification of feature	<input type="checkbox"/>		Release 98	<input type="checkbox"/>
	D Editorial modification	<input type="checkbox"/>		Release 99	<input checked="" type="checkbox"/>
			Release 00	<input type="checkbox"/>	

Reason for change:
1) The MS in the CALL CONFIRMED message may send extended BC-IE (containing octets 6d-6g) when no BC-IE is received. This change is needed in order to allow PSTN originated Mobile terminated calls in case of single numbering in UMTS.
2) H.223&H245 is also supported in GSM

Clauses affected:

Other specs affected:	Other 3G core specifications	<input checked="" type="checkbox"/>	→ List of CRs:	27.001 R00 CR 024r1
	Other GSM core specifications	<input type="checkbox"/>	→ List of CRs:	
	MS test specifications	<input type="checkbox"/>	→ List of CRs:	
	BSS test specifications	<input type="checkbox"/>	→ List of CRs:	
	O&M specifications	<input type="checkbox"/>	→ List of CRs:	

Other comments:

8.3.3.1 Indication in case of Mobile terminating calls

In support of:

- PSTN originated calls; and
- ISDN originated calls using 3,1 kHz audio Bearer Capability (BC); as well as
- ISDN originated calls using unrestricted digital Bearer Capability but not specifying all parameters for deducing a Bearer Service.

Mobile specific requirements to be dealt with in the Bearer Capability information element the call confirmed message has been introduced in the call control protocol (3G TS 24.008). This also allows for renegotiation of specific parameters at the beginning of the connection set-up process. The specific parameters are:

- a) mobile specific requirements:
- Connection element (transparent/non transparent);
 - Structure (note 1);
 - Synchronous/Asynchronous (note 8);
 - Rate adaptation/other rate adaptation (note 9);
 - User information layer 2 protocol (note 1);
 - Intermediate rate (note 2), (note 3);
 - Modem Type (note 1), (note 3);
 - User Rate (note 3);
 - Compression ,
 - Fixed network user rate, (note 3) (note 4);
 - Other modem type, (note 3) (note 4);
 - User initiated modification indication (note 4).

The following parameters are indicated by the MS to the network, only:

- Acceptable channel codings (note 5);
- Maximum number of traffic channels, (note 5);
- Wanted air interface user rate (note 6) (note 7);
- Asymmetry preference indication (note 7).

NOTE 1: This parameter is correlated with the value of the parameter connection element.

NOTE 2: For non-transparent services this parameter is correlated with the value of the parameter negotiation of intermediate rate requested.

NOTE 3: Modification of these parameters may be proposed by the MS. The Network may accept it or not.

NOTE 4: This parameter shall be included by the MS only in case it was received from the network.

NOTE 5: This parameter shall be included only in case the parameter 'fixed network user rate' is included.

NOTE 6: This parameter shall be included only for non-transparent services and in case the parameter 'fixed network user rate' is included.

NOTE 7: This parameter has to be included if EDGE channel coding(s) are included in Acceptable channel codings. In cases where this parameter would not otherwise be included, the value is set to 'Air interface user rate not applicable' or 'User initiated modification not requested' or "No preference".

NOTE 8: For FTM and PIAFS, this parameter may be negotiated as in table B.4e. How the subscription for BS20 is assured, is an operator matter.

NOTE 9: For FTM, PIAFS or Multimedia, this parameter may be negotiated as in table B.4f.

b) requirements with effects at the partner terminal:

- Number of data bits;
- Number of stop bits;
- Parity.

The MS indicates the radio channel requirement in the call confirmed message. If the MS indicates the support of "dual" (HR and FR channels) the final decision, which radio channel is chosen, is done by the network in an RR message. The radio channel requirement is ignored in UMTS, see Table B.5a in Annex B.

If the network proposes optional support of both transparent and non transparent connection elements but does not indicate a user information layer 2 protocol, the MS shall set the appropriate value, if choosing non transparent in the call confirmed message and out-band flow control is not requested, see B.1.1.2.

Additionally the values of the parameters structure, modem type and intermediate rate have to be set in conformance with the values of the parameters radio channel requirements, negotiation of intermediate rate requested and connection element.

Subclause B.1.1.2 and table B.1 in the annex B describe the negotiation procedure. Annex B table B.4 describes the selection of the modem type and the dependence on the value of the parameter connection element. Annex B table B.4 describes the selection of the intermediate rate and user rate and their dependence upon the value of the NIRR parameter and the equipment capabilities.

The following MT cases can be deduced from the individual call set-up request conditions:

- a) If the set-up does not contain a BC information element, the MS in the call confirmed message shall include any BC information (single or multiple BC-IE). In case of multiple BC-IEs one BC-IE must indicate the information transfer capability "speech". A speech BC-IE together with a 3,1kHz multimedia BC-IE indicates the support of a fallback to speech (ref. to TS 29.007 and TS 24.008).
- b) If the set-up message contains a single BC-IE, the MS in the call confirm message shall use either a single BC-IE, if it wants to negotiate mobile specific parameter values, or, unless otherwise specified in annex B, no BC-IE, if it agrees with the requested ones.
- c) If the set-up contains a multiple BC-IE, the MS in the call confirmed message shall use either a multiple BC-IE, if it wants to negotiate mobile specific parameter values, or, unless otherwise specified in annex B, no BC-IE, if it agrees with the requested ones. In case of a 3,1kHz multimedia setup the MS can either accept the possibility of a fallback to speech by responding with two BC-IEs or with no BC-IEs or turn the call to a speech call by sending only a speech BC-IE in the call confirm message or turn the call to a multimedia only call (i.e. no fallback to speech allowed) by sending only a multimedia BC-IE in the call confirm message. Alternatively a single BC-IE containing fax group 3 only shall be used if a multiple BC-IE requesting speech alternate fax group 3 is received and the MS is not able to support the speech capability. Annex B, table B.7, describes the negotiation rules.

If the BC-IE contains 3,1 kHz ex PLMN, the MS is allowed to negotiate all mobile specific parameter values listed above. If the BC-IE contains facsimile group 3, the MS is allowed to negotiate the connection element (transparent/non transparent) only. In any case, if the set-up message requests a "single service", the MS must not answer in the call confirmed message requesting a "dual service" and vice versa.

However, for dual services with repeat indicator set to circular (alternate) the MS may change the sequence of dual BC-IEs within the call confirmed message (preceded by the same value of the repeat indicator), if it wants to start with a different Bearer Capability than proposed by the network as the initial one.

In addition, the MS may propose to the network to modify User Rate, Modem Type and Intermediate Rate in the CALL CONFIRMED message. The network may accept or release the call.

If the BC-IE received from the network contains the parameters 'fixed network user rate', 'other modem type' and possibly the 'user initiated modification', the MS can either:

- a) if in GSM, discard these parameters; or
- b) include the possibly modified values for the 'fixed network user rate' and 'other modem type' in the BC-IE of the call confirmed message. The network might accept or reject the modified values. In this case the MS shall also include the parameters 'maximum number of traffic channels' and 'acceptable channel codings'. Additionally for non-transparent services, the MS shall also include the parameters 'wanted air interface user rate' and the 'user initiated modification indication'.

In case a), The MS shall use the fall-back bearer service indicated by the remaining parameters of the BC-IE on a single slot configuration (reference GSM 04.21).

In GSM case b), a single slot configuration shall be used by the MS, in case the 'maximum number of traffic channels' is set to "1 TCH" and the 'user initiated modification indication' is set either to "user initiated modification not required" or to "user initiated modification up to 1TCH may be requested"; other wise the MS shall use a multislot configuration (reference GSM 04.21).

In case the 'acceptable channel codings' is indicated by the MS, the decision which channel coding is used is done by the network and indicated to the mobile station with an RR message. This RR message may also assign an asymmetric channel coding. The 'acceptable channel codings' parameter takes precedence over the 'negotiation of intermediate rate requested' parameter for non-transparent services. Also the intermediate rate and user rate per traffic channel in a multislot configuration are not indicated by the 'intermediate rate' and 'user rate' parameters of the BC-IE, but depend on the chosen channel coding only.

If the parameters 'fixed network user rate', 'other modem type' were not included in the BC-IE received, or no BC-IE was received, the MS shall not include these parameters in the CALL CONFIRMED message (i.e. octets 6d, 6e, 6f, and 6g ref. to 3G TS 24.008). If the MS receives a BC-IE in the SETUP message containing the parameters 'fixed network user rate', 'other modem type', the MS may include these parameters in the BC-IE of the CALL CONFIRMED message (i.e. octets 6d, 6e, 6f, and 6g ref. to 3G TS 24.008), with parameter values negotiated according to Annex B. If no BC-IE is received in the SETUP message, the MS may include these parameters in the CALL CONFIRMED message. However, in this case, the network may release the call if it does not support these parameters.

B.1.3.1.6 3G-H.324/M Case

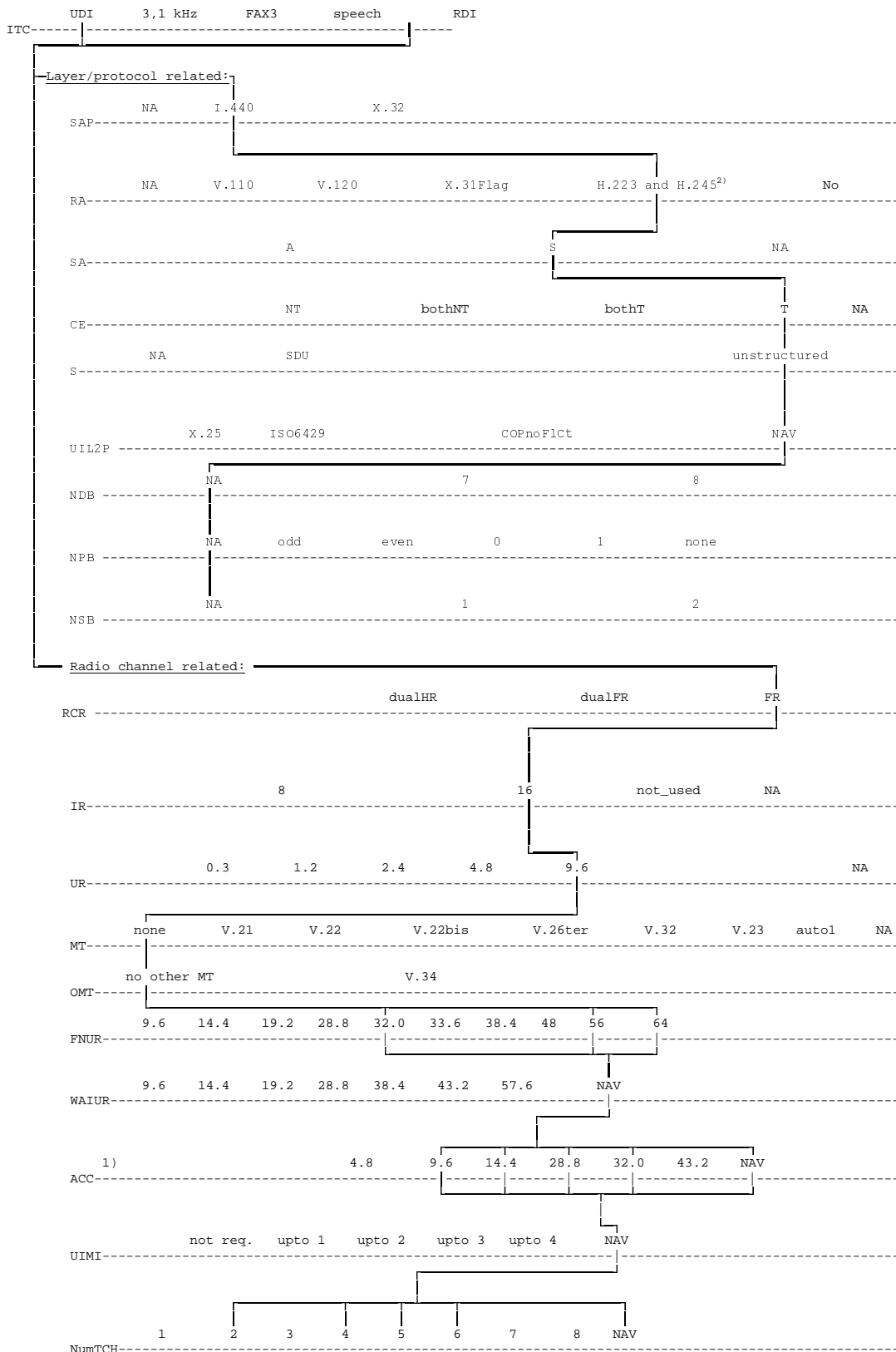

1) ACC may have several values simultaneously (bit map coding).

2) This value is interpreted as "No rate adaptation" in GSM.

B.1.3.2.3 3G-H.324/M Case

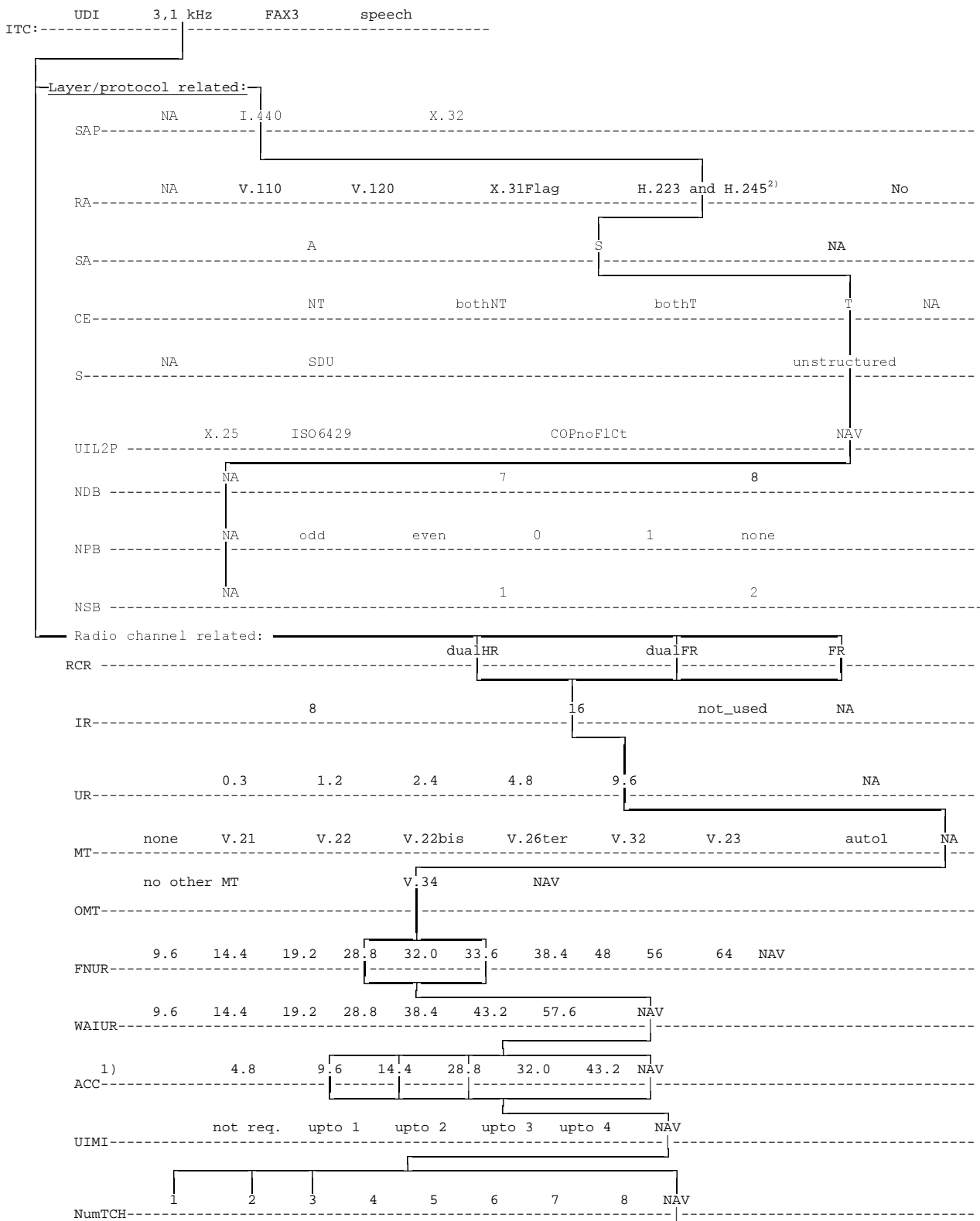

1) ACC may have several values simultaneously (bit map coding).

2) — This value is interpreted as "No rate adaptation" in GSM.

3GPP N3 Meeting #12
Seattle, USA, 26 August – 1 September 2000

Document **N3-000428**

e.g. for 3GPP use the format TP-99xxx
or for SMG, use the format P-99-xxx

CHANGE REQUEST

Please see embedded help file at the bottom of this page for instructions on how to fill in this form correctly.

27.001 CR 036

Current Version: **4.0.0**

GSM (AA.BB) or 3G (AA.BBB) specification number ↑

↑ CR number as allocated by MCC support team

For submission to: **CN#9**
list expected approval meeting # here
↑

for approval
for information

strategic
non-strategic (for SMG use only)

Form: CR cover sheet, version 2 for 3GPP and SMG The latest version of this form is available from: <ftp://ftp.3gpp.org/Information/CR-Form-v2.doc>

Proposed change affects: (U)SIM ME UTRAN / Radio Core Network
(at least one should be marked with an X)

Source: TSG_N3. **Date:** 2000-08-24

Subject: RCR is not indicated from the network to the MS

Work item: TEI

Category: <i>(only one category shall be marked with an X)</i>	F Correction	<input type="checkbox"/>	Release:	Phase 2	<input type="checkbox"/>
	A Corresponds to a correction in an earlier release	<input type="checkbox"/>		Release 96	<input type="checkbox"/>
	B Addition of feature	<input type="checkbox"/>		Release 97	<input type="checkbox"/>
	C Functional modification of feature	<input type="checkbox"/>		Release 98	<input type="checkbox"/>
	D Editorial modification	<input checked="" type="checkbox"/>		Release 99	<input type="checkbox"/>
			Release 00	<input checked="" type="checkbox"/>	

Reason for change: Radio Channel Requirement (RCR) is a BC-IE parameter that is indicated by the MS to the network. The network does not indicate any RCR to the MS. This is made clearer.

Clauses affected:

Other specs affected:	Other 3G core specifications	<input checked="" type="checkbox"/>	→ List of CRs:	29.007 CR 028
	Other GSM core specifications	<input type="checkbox"/>	→ List of CRs:	
	MS test specifications	<input type="checkbox"/>	→ List of CRs:	
	BSS test specifications	<input type="checkbox"/>	→ List of CRs:	
	O&M specifications	<input type="checkbox"/>	→ List of CRs:	

Other comments:

8.3.3.1 Indication in case of Mobile terminating calls

In support of:

- PSTN originated calls; and
- ISDN originated calls using 3,1 kHz audio Bearer Capability (BC); as well as
- ISDN originated calls using unrestricted digital Bearer Capability but not specifying all parameters for deducing a Bearer Service.

Mobile specific requirements to be dealt with in the Bearer Capability information element the call confirmed message has been introduced in the call control protocol (3G TS 24.008). This also allows for renegotiation of specific parameters at the beginning of the connection set-up process. The specific parameters are:

- a) mobile specific requirements:
- Connection element (transparent/non transparent);
 - Structure (note 1);
 - Synchronous/Asynchronous (note 8);
 - Rate adaptation/other rate adaptation (note 9);
 - User information layer 2 protocol (note 1);
 - Intermediate rate (note 2), (note 3);
 - Modem Type (note 1), (note 3);
 - User Rate (note 3);
 - Compression ,
 - Fixed network user rate, (note 3) (note 4);
 - Other modem type, (note 3) (note 4);
 - User initiated modification indication (note 4).

The following parameters are indicated by the MS to the network, only:

- Radio Channel Requirement
- Acceptable channel codings (note 5);
- Maximum number of traffic channels, (note 5);
- Wanted air interface user rate (note 6) (note 7);
- Asymmetry preference indication (note 7).

NOTE 1: This parameter is correlated with the value of the parameter connection element.

NOTE 2: For non-transparent services this parameter is correlated with the value of the parameter negotiation of intermediate rate requested.

NOTE 3: Modification of these parameters may be proposed by the MS. The Network may accept it or not.

NOTE 4: This parameter shall be included by the MS only in case it was received from the network.

NOTE 5: This parameter shall be included only in case the parameter 'fixed network user rate' is included.

NOTE 6: This parameter shall be included only for non-transparent services and in case the parameter 'fixed network user rate' is included.

NOTE 7: This parameter has to be included if EDGE channel coding(s) are included in Acceptable channel codings. In cases where this parameter would not otherwise be included, the value is set to 'Air interface user rate not applicable' or 'User initiated modification not requested' or "No preference".

NOTE 8: For FTM and PIAFS, this parameter may be negotiated as in table B.4e. How the subscription for BS20 is assured, is an operator matter.

NOTE 9: For FTM, PIAFS or Multimedia, this parameter may be negotiated as in table B.4f.

b) requirements with effects at the partner terminal:

- Number of data bits;
- Number of stop bits;
- Parity.

The MS indicates the radio channel requirement in the call confirmed message. If the MS indicates the support of "dual" (HR and FR channels) the final decision, which radio channel is chosen, is done by the network in an RR message. The radio channel requirement is ignored in UMTS, see Table B.5a in Annex B.

If the network proposes optional support of both transparent and non transparent connection elements but does not indicate a user information layer 2 protocol, the MS shall set the appropriate value, if choosing non transparent in the call confirmed message and out-band flow control is not requested, see B.1.1.2.

Additionally the values of the parameters structure, modem type and intermediate rate have to be set in conformance with the values of the parameters radio channel requirements, negotiation of intermediate rate requested and connection element.

Subclause B.1.1.2 and table B.1 in the annex B describe the negotiation procedure. Annex B table B.4 describes the selection of the modem type and the dependence on the value of the parameter connection element. Annex B table B.4 describes the selection of the intermediate rate and user rate and their dependence upon the value of the NIRR parameter and the equipment capabilities.

The following MT cases can be deduced from the individual call set-up request conditions:

- a) If the set-up does not contain a BC information element, the MS in the call confirmed message shall include any BC information (single or multiple BC-IE). In case of multiple BC-IEs one BC-IE must indicate the information transfer capability "speech". A speech BC-IE together with a 3,1kHz multimedia BC-IE indicates the support of a fallback to speech (ref. to TS 29.007 and TS 24.008).
- b) If the set-up message contains a single BC-IE, the MS in the call confirm message shall use either a single BC-IE, if it wants to negotiate mobile specific parameter values, or, unless otherwise specified in annex B, no BC-IE, if it agrees with the requested ones.
- c) If the set-up contains a multiple BC-IE, the MS in the call confirmed message shall use either a multiple BC-IE, if it wants to negotiate mobile specific parameter values, or, unless otherwise specified in annex B, no BC-IE, if it agrees with the requested ones. In case of a 3,1kHz multimedia setup the MS can either accept the possibility of a fallback to speech by responding with two BC-IEs or with no BC-IEs or turn the call to a speech call by sending only a speech BC-IE in the call confirm message or turn the call to a multimedia only call (i.e. no fallback to speech allowed) by sending only a multimedia BC-IE in the call confirm message. Alternatively a single BC-IE containing fax group 3 only shall be used if a multiple BC-IE requesting speech alternate fax group 3 is received and the MS is not able to support the speech capability. Annex B, table B.7, describes the negotiation rules.

If the BC-IE contains 3,1 kHz ex PLMN, the MS is allowed to negotiate all mobile specific parameter values listed above. If the BC-IE contains facsimile group 3, the MS is allowed to negotiate the connection element (transparent/non transparent) only. In any case, if the set-up message requests a "single service", the MS must not answer in the call confirmed message requesting a "dual service" and vice versa.

However, for dual services with repeat indicator set to circular (alternate) the MS may change the sequence of dual BC-IEs within the call confirmed message (preceded by the same value of the repeat indicator), if it wants to start with a different Bearer Capability than proposed by the network as the initial one.

In addition, the MS may propose to the network to modify User Rate, Modem Type and Intermediate Rate in the CALL CONFIRMED message. The network may accept or release the call.

If the BC-IE received from the network contains the parameters 'fixed network user rate', 'other modem type' and possibly the 'user initiated modification', the MS can either:

- a) if in GSM, discard these parameters; or
- b) include the possibly modified values for the 'fixed network user rate' and 'other modem type' in the BC-IE of the call confirmed message. The network might accept or reject the modified values. In this case the MS shall also include the parameters 'maximum number of traffic channels' and 'acceptable channel codings'. Additionally for non-transparent services, the MS shall also include the parameters 'wanted air interface user rate' and the 'user initiated modification indication'.

In case a), The MS shall use the fall-back bearer service indicated by the remaining parameters of the BC-IE on a single slot configuration (reference GSM 04.21).

In GSM case b), a single slot configuration shall be used by the MS, in case the 'maximum number of traffic channels' is set to "1 TCH" and the 'user initiated modification indication' is set either to "user initiated modification not required" or to "user initiated modification up to 1TCH may be requested"; other wise the MS shall use a multislot configuration (reference GSM 04.21).

In case the 'acceptable channel codings' is indicated by the MS, the decision which channel coding is used is done by the network and indicated to the mobile station with an RR message. This RR message may also assign an asymmetric channel coding. The 'acceptable channel codings' parameter takes precedence over the 'negotiation of intermediate rate requested' parameter for non-transparent services. Also the intermediate rate and user rate per traffic channel in a multislot configuration are not indicated by the 'intermediate rate' and 'user rate' parameters of the BC-IE, but depend on the chosen channel coding only.

If the parameters 'fixed network user rate', 'other modem type' were not included in the BC-IE received, or no BC-IE was received, the MS shall not include these parameters in the CALL CONFIRMED message (i.e. octets 6d, 6e, 6f, and 6g ref. to 3G TS 24.008).

CHANGE REQUEST

Please see embedded help file at the bottom of this page for instructions on how to fill in this form correctly.

29.007 CR 028

Current Version: **3.5.0**

GSM (AA.BB) or 3G (AA.BBB) specification number ↑

↑ CR number as allocated by MCC support team

For submission to: **CN#9**
list expected approval meeting # here ↑

for approval
for information

strategic
non-strategic (for SMG use only)

Form: CR cover sheet, version 2 for 3GPP and SMG The latest version of this form is available from: <ftp://ftp.3gpp.org/Information/CR-Form-v2.doc>

Proposed change affects: (U)SIM ME UTRAN / Radio Core Network
(at least one should be marked with an X)

Source: TSG_N3 **Date:** 2000-08-24

Subject: RCR is not indicated from the network to the MS

Work item: TEI

Category: (only one category shall be marked with an X)	F Correction	<input type="checkbox"/>	Release:	Phase 2	<input type="checkbox"/>
	A Corresponds to a correction in an earlier release	<input type="checkbox"/>		Release 96	<input type="checkbox"/>
	B Addition of feature	<input type="checkbox"/>		Release 97	<input type="checkbox"/>
	C Functional modification of feature	<input type="checkbox"/>		Release 98	<input type="checkbox"/>
	D Editorial modification	<input checked="" type="checkbox"/>		Release 99	<input type="checkbox"/>
			Release 00	<input checked="" type="checkbox"/>	

Reason for change: Radio Channel Requirement (RCR) is a BC-IE parameter that is indicated by the MS to the network. The network does not indicate any RCR to the MS. This is made clearer.

Clauses affected:

Other specs affected:	Other 3G core specifications	<input checked="" type="checkbox"/>	→ List of CRs:	27.001 CR 036
	Other GSM core specifications	<input type="checkbox"/>	→ List of CRs:	
	MS test specifications	<input type="checkbox"/>	→ List of CRs:	
	BSS test specifications	<input type="checkbox"/>	→ List of CRs:	
	O&M specifications	<input type="checkbox"/>	→ List of CRs:	

Other comments:

9.2.2.1 Multi-numbering Scheme

In this scheme, the HPLMN will allocate a number of MSISDNs to a subscriber and associate with each of these numbers a Bearer Capability to identify a Bearer or a Teleservice. This Bearer Capability comprises a complete PLMN Bearer Capability (PLMN BC) information element with contents according to 3G TS 27.001 and coded as per 3G TS 24.008. In either case, when the HLR receives an interrogation relating to an incoming call (i.e. the MAP "Send Routing Information" procedure), it requests a roaming number (MSRN) from the VLR. This request will contain the PLMN BC reflecting the service associated with the called MSISDN, i.e. the PLMN BC is passed to the VLR within the MAP parameter "GSM Bearer Capability" of the message "Provide Roaming Number".

At the VMSC, when the incoming call arrives, the PLMN BC associated with the MSRN are retrieved from the VLR and sent to the MS at call set-up.

Where the PLMN specific parameters "connection element" and "radio channel" requirements contained in the retrieved PLMN BC-IE, indicates dual capabilities then the VMSC shall set them-it according to its capabilities/preferences. Additionally the parameters correlated to those-mentioned-above "connection element" shall be modified in accordance with 3G TS 27.001.

The same applies to the parameter modem type if "autobauding type 1" is indicated but the IWF does not support this feature. The parameter "data compression" may also be modified according to the capabilities of the IWF.

Where single capabilities are indicated then the VMSC shall use the requested values if it is able to support the service requested. If it is unable to support the requested service then it shall set them according to its capabilities/preferences.

Where the Compatibility Information is provided in a degree exhaustive to deduce a PLMN Basic Service (see application rules in subclause 10.2.2), then the VMSC in providing the PLMN BC IE in the setup message shall set the PLMN specific parameters to its capabilities/preferences.

On receipt of a Set-up message containing the compatibility information, the MS will analyse the contents to decide whether the service can be supported (with or without modification, see 3G TS 27.001) and the call will be accepted or rejected as appropriate.

These negotiable parameters in the PLMN BC-IE are: Connection Element (Transparent/non-transparent), Data Compression, number of data bits, number of stop bits and parity as well as the correlated parameters Structure, Intermediate Rate, Modem Type and User Information Layer 2 Protocol. For multislot, 14,4 kbit/s or EDGE--operations additionally the parameters Fixed Network User Rate, Other Modem Type and User Initiated Modification Indicator can be negotiated. For FTM, PIAFS and Multimedia, Rate adaption/Other rate adaption can be negotiated. For FTM and PIAFS, Synchronous/asynchronous can be negotiated, see 3G TS 27.001. This negotiation takes place by means of the MS reflecting back to the MSC a complete bearer capability information element in the call confirm message, with the relevant parameters changed. If this does not take place (i.e. if there is no PLMN BC present in the call confirmed message), then the MSC will assume that the values originally transmitted to the MS are accepted.

In case the PLMN-BC sent with the set-up message contained the "fixed network user rate", "other modem type" and "user initiated modification parameter" parameters and no multislot, 14,4 kbit/s, and/or EDGE--related parameters (refer to 3G TS 27.001) are received in the PLMN-BC of the call confirmed message or no PLMN-BC is received, the MSC shall discard the "fixed network user rate", "other modem type" and "user initiated modification parameter" parameters - the MSC shall use the fall-back bearer service indicated by the remaining parameters of the PLMN-BC on a singleslot configuration (refer to GSM 08.20 and GSM 04.21) on the MSC/IWF-BSS link.

On the other hand, if the PLMN-BC received with the call confirmed message contain(s) multislot, 14.4kbit/s or EDGE-related parameters the MSC shall apply a singleslot configuration when the "maximum number of traffic channels" indicates '1 TCH' and the "user initiated modification indicator" indicates either 'user initiated modification not requested' or 'user initiated modification upto 1 TCH/F requested', otherwise a multislot configuration (refer to GSM 08.20 and GSM 04.21) shall be used on the MSC/IWF-BSS link. In case the MS signals an ACC containing TCH/F4.8 only and the network does not support TCH/F4.8 channel coding, then the MSC may act as if TCH/F9.6 were included in the ACC.

In addition the MS may propose to the network to modify the User Rate as well as the correlated parameters Modem Type and Intermediate Rate in the CALL CONFIRMED message. The network may accept or release the call. For multislot, 14.4kbit/s or EDGE--operations, the MS may also propose to the network to modify the Fixed Network User Rate and Other Modem Type parameters (see 3G TS 27.001).

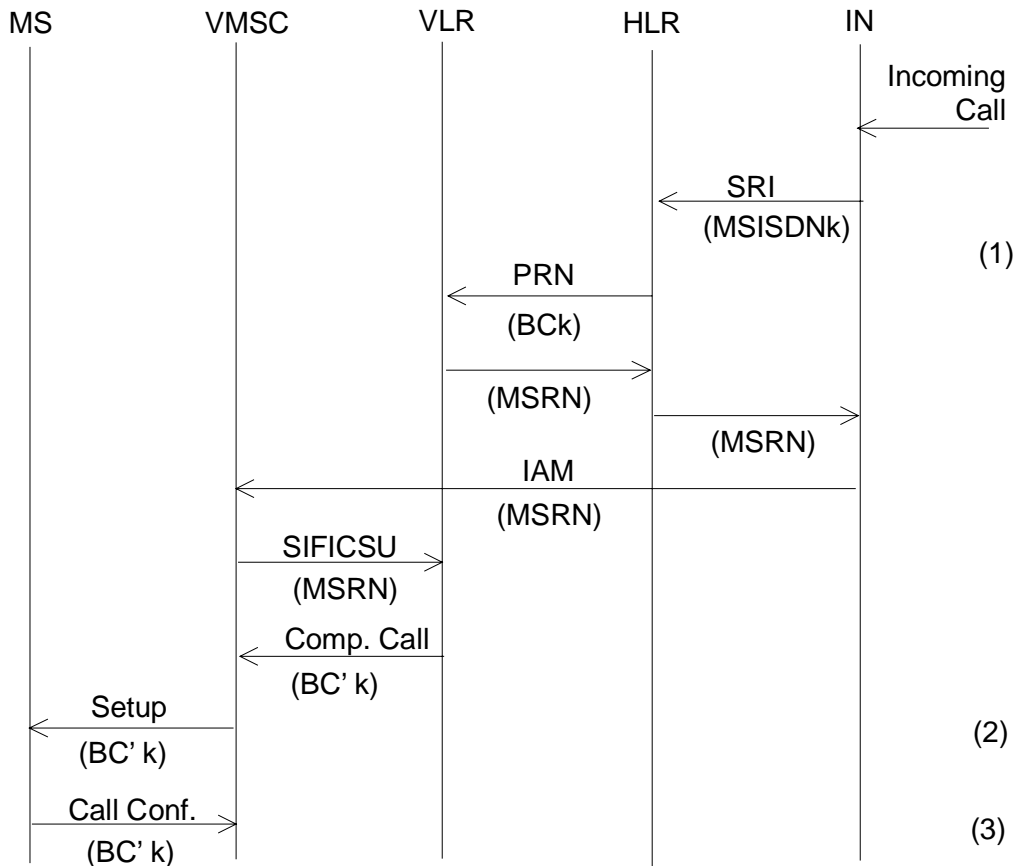

- NOTES: (1) The HLR translates the received MSISDN_ called address (MSISDNk) into the relevant bearer capability information (Bck).
 (2) Some parameters of Bck may be provided/modified according to the MSC's capabilities/preferences. See subclause 9.2.2.
 (3) In the "Call Confirm" message, the MS may modify some parameters of the BC. See subclause 9.2.2.

Abbr.: SRI - Send Routing Information.
 PRN - Provide Roaming Number.
 MSRN - Mobile Station Roaming Number.
 IAM - Initial Address Message.
 SIFICSU - Send Information For Incoming Call Set Up.

Figure 2: Call Flow for a mobile terminated, PSTN originated call where the compatibility information provided are not exhaustive for deducing a PLMN Bearer Service; HLR uses multiple MSISDN numbers with corresponding BCs

10.2.2.6 Mapping Functions

The following tables (7A + 7B) show that only the ISDN BC is used for mapping (exceptions are indicated).

NOTE: The ISDN/ PLMN BC-IE mapping shall be performed as specified in tables 7A and 7B. This shall be done to allow setup of a compatible end-to-end connection between two MSs or one MS and an ISDN terminal.

In the following tables 7A and 7B the comparison is drawn between parameters in the PLMN call set up request message and that of the ISDN call set up request message. In some cases no comparable values are available and these will be marked as such. In these cases reference will need to be made to the table of network interworking in 3G TS 29.007 to identify the appropriate choice. In some cases it is not necessary to support a particular option, and in this case those parameters will be annotated appropriately.

The PLMN parameters and values are as in 3G TS 24.008 in combination as in 3G TS 27.001. The ISDN parameters and values are as in Q.931 (05/98).

Table 7A: Comparable setting of parameters in PLMN and ISDN: Mobile Originated

Octet	PLMN BC parameter value	Octet	ISDN BC parameter value
1	Bearer Capability IEI	1	Bearer Capability IEI
2	Length of BC contents	2	Length of BC contents
3 #7..6	Radio channel requirement half rate channel full rate channel dual, full, rate preferred dual, half rate preferred		No comparable field
3 #5	Coding Standard GSM standard coding	3 #7..6	Coding Standard CCITT standardized coding
3 #4	Transfer mode circuit mode packet mode (note7)	4 #7..6	Transfer mode circuit mode packet mode
3 #3..1	Information transfer capability speech unrestricted digital 3,1 kHz audio ex PLMN facsimile group 3 (note 1) other ITC (see octet 5a)	3 #5..1	Information transfer capability speech unrestricted digital 3,1 kHz audio 3,1 kHz audio no comparable value
5a #7..6	Other ITC restricted digital		(note 18)
4 #7	Compression (note 14) data compression allowed data compression not allowed		No comparable field
4 #6..5	Structure SDU integrity unstructured	4a #7..5	Structure (note 4)
4 #4	Duplex mode half duplex full duplex	5d #7	Duplex mode half duplex full duplex
4 #3	Configuration point to point	4a #4..3	Configuration (note 4)
4 #1	Establishment demand	4a #2..1	Establishment (note 4)
4	NIRR (note 12) no meaning Data ≤ 4.8kbit/s, FR nt, 6kbit/s radio interface is requested		No comparable field

(continued)

Table 7A (continued): Comparable setting of parameters in PLMN and ISDN: Mobile Originated

Octet	PLMN BC parameter value	Octet	ISDN BC parameter value
5 #5..4	Rate adaptation no rate adaptation (note 2) V.110, I.460/X.30 rate adaptation CCITT X.31 flag stuffing No comparable value(note 11) No comparable value(note 11) No comparable value(note 11) other rate adaptation (see octet 5a)	5 #5..1	User information layer 1 protocol no comparable value CCITT standardized rate adaption V.110, I.460/X.30 CCITT standardized rate adaption X.31 flag stuffing Recommendation G.711 μ -law Recommendation G.711 A-law (note 3) Recommendation G.721 32 kbit/s ADPCM and I.460 No comparable value
5a #5..4	Other rate adaptation V.120 (note 17) PIAFS (note 27) H.223 & H.245		No comparable value H.223 & H.245 (note 26)
5 #3..1	Signalling access protocol I.440/I.450 X.21 X.28, ded.PAD, indiv.NUI (note 24) X.28, ded PAD, univ.NUI (note 24) X.28, non-ded PAD X.32		No comparable field
6 #1	Synchronous/asynchronous synchronous asynchronous	5a #7	Synchronous/asynchronous synchronous asynchronous (note 25)
6 #5..2	User info. layer 1 protocol default layer 1 protocol	5 #5..1	User info. layer 1 protocol see section under rate adaptation for 3G TS 24.008 above
6a #7	Number of stop bits 1 bit 2 bits	5c #7..6	Number of stop bits 1 bit 2 bits
6a #6	Negotiation In band neg. not possible no comparable value	5a #6	Negotiation In band neg. not possible In band neg. possible (note 10)
6a #5	Number of data bits 7 bits 8 bits	5c #5..4	Number of data bits excluding parity if present 7 bits 8 bits
6a #4..1	User rate 0.3 kbit/s 1.2 kbit/s 2.4 kbit/s 4.8 kbit/s 9.6 kbit/s 12 kbit/s (note 7) 1.2 kbit/s / 75 bit/s (note 24) any value no comparable value	5a #5..1	User rate 0.3 kbit/s 1.2 kbit/s 2.4 kbit/s 4.8 kbit/s 9.6 kbit/s 12 kbit/s 75 bit/s / 1.2 kbit/s 19.2 kbit/s (note 14) Ebits or inband negotiation (note 10)

(continued)

Table 7A (continued): Comparable setting of parameters in PLMN and ISDN: Mobile Originated

Octet	PLMN BC parameter value	Octet	ISDN BC parameter value
6b #7..6	Intermediate rate 8 kbit/s 16 kbit/s any value	5b #7..6	Intermediate rate (note 13) 8 kbit/s or not used 16 kbit/s or not used 32 kbit/s or not used (note 14)
6b #5	NIC on Tx does not require requires (note7)	5b #5b	NIC on Tx does not require requires (note 8)
6b #4	NIC on Rx cannot accept can accept (note 7)	5b #4	NIC on Rx cannot accept can accept (note 8)
6b #3..1	Parity information odd even none forced to 0 forced to 1	5c #3..1	Parity information odd even none forced to 0 forced to 1
6c #7..6	Connection element transparent non-transparent (RLP) both, transp. preferred both, non-transp. preferred		No comparable field
6c #5..1	Modem type none V.21 V.22 V.22bis V.23 (note 24) V.26ter V.32 modem for undef. interface autobauding type 1	5d #6..1	Modem type no comparable value (note 5) V.21 V.22 V.22bis V.23 V.26ter V.32 No comparable value (note 5) No comparable value (note 5, note 10)
7 #5..1	User info. layer 2 protocol X.25 link level ISO 6429, codeset 0 COPnoFICt videotex profile 1 (note 7) X.75 layer 2 modified (CAPI)	6	User info. layer 2 prot. (note 6) X.25 link level no comparable value no comparable value no comparable value X.25 link level
6d #5..1	Fixed network user rate (note 15) FNUR not applicable (note 7) 9,6 kbit/s 12 kbit/s (note 7) 14,4 kbit/s 19,2 kbit/s 28,8 kbit/s 32,0 kbit/s 33,6 kbit/s 38,4 kbit/s 48,0 kbit/s 56,0 kbit/s 64,0 kbit/s	5a #5..1	User rate no comparable value 9,6 kbit/s 12 kbit/s 14,4 kbit/s 19,2 kbit/s 28,8 kbit/s 32,0 kbit/s no comparable value 38,4 kbit/s 48,0 kbit/s 56,0 kbit/s no comparable value (note 16)

(continued)

Table 7A (concluded): Comparable setting of parameters in PLMN and ISDN: Mobile Originated

Octet	PLMN BC parameter value	Octet	ISDN BC parameter value
6e #3..1	Maximum number of traffic channels 1 TCH 2 TCH 3 TCH 4 TCH 5 TCH 6 TCH 7 TCH (note 7) 8 TCH (note 7)		No comparable field
6f #4..1	Wanted air interface user rate (note 23) air interface user rate not applicable (note 7) 9,6 kbit/s 14,4 kbit/s 19,2 kbit/s 28,8 kbit/s 38,4 kbit/s 43,2 kbit/s 57,6 kbit/s interpreted by the network as 38.4 kbit/s (note 7)		No comparable field
6d #7..6	Other modem type (note 15) No other modem type V.34	5d #6..1	Modem type no comparable value V.34
6e #7..4	Acceptable channel coding(s) TCH/F4.8 acceptable (note 19) TCH/F9.6 acceptable TCH/F14.4 acceptable		No comparable field
6f #7..5	User initiated modification indicator (note 23) User initiated modification not required User initiated modification upto 1 TCH/F may be requested User initiated modification upto 2 TCH/F may be requested User initiated modification upto 3 TCH/F may be requested User initiated modification upto 4 TCH/F may be requested		No comparable field
6g #7..5	Acceptable channel coding(s) (note 20) TCH/F28.8 acceptable TCH/F32.0 acceptable (note 21) TCH/F43.2 acceptable (note 22)		No comparable field
6g #4..3	Asymmetry preference indication (Note 23) no preference up link biased asymmetry preference down link biased asymmetry preference		No comparable field

The application rules for coding the information elements ISDN-BC/LLC/HLC as set out in ETR 018 and Q.931 (05/98) shall apply.

Other field values in the ISDN BC-IE not supported in 3G TS 24.008 are:

- Information transfer rate: In this case default 64 kbit/s is selected.
- Flow control on transmission: This shall be selected if outband flow control applies.
- Flow control on reception: This shall be selected if outband flow control applies.

NOTE 0: Outband flow control is indicated by the absence of the UIL2P parameter for non-transparent connections.

User information layer 3 protocol: Octet 7 shall not be sent unless specific application rules are given for particular cases (to be defined by PLMN). End-to-end significant User Information layer 3 protocol shall be sent by LLC.

NOTE 1: In the case where PLMN BC "Information Transfer Capability" indicates "Facsimile group 3" and only a single PLMN BC is contained in the call set-up request then this shall be mapped to an ISDN BC with:

- coding standard: CCITT;
- information transfer capability: 3,1 kHz audio;
- transfer mode: circuit;
- information transfer rate: 64 kbit/s;
- user layer 1 protocol: G711 A-law or μ -law (PCS-1900); and
- if an HLC is not present, the network will insert a "Facsimile group 2/3" HLC;
- if an HLC element is present, the network will pass it through unmodified.

In the case where PLMN BC "Information Transfer Capability" indicates "Facsimile group 3" and two PLMN BCs are contained in the call set-up request, then the same ISDN BC as mentioned above is created. If the first PLMN BC indicates "facsimile group 3" an HLC "facsimile group 2/3" will be inserted by the network (if not received from the MS). However if the first PLMN BC indicates "speech", the network will not send a HLC, irrespective where a HLC was received from the MS or not.

NOTE 2: This value is present in combination with information transfer capability parameter value "3,1 kHz audio Ex PLMN" or "facsimile group 3" and will therefore be mapped to the value "Recommendation G.711 A-law" or Recommendation G.711 μ -law" (PCS-1900) of the Q.931 (05/98) parameter user layer 1 protocol (see note 3).

NOTE 3: The value "Recommendation G.711 A-law" or "Recommendation G.711 μ -law" (PCS-1900) applies only when the Q.931 (05/98) parameter information transfer capability indicates "3,1 kHz audio" or "speech".

NOTE 4: When interworking with an ISDN according to ETS 300 102-1 octets 4a and 4b shall not be included because default values apply. In an ISDN according to Q.931 (05/98) these octets no more exist.

NOTE 5: In this case octet 5d shall not be included.

NOTE 6: Octet 6 shall not be sent unless specific application rules are given for a particular case (PLMN specified). End-to-end significant user information layer 2 protocol shall be sent by LLC.

NOTE 7: Not used for currently defined Bearer Services and Teleservices.

NOTE 8: These values will only be set if the "Information Transfer Capability" indicates "3,1 kHz audio", synchronous data transmission is used and octet 5b of the ISDN BC is present.

NOTE 9: (VOID).

NOTE 10: The PLMN BC-IE parameter value "autobauding modem type 1" will be mapped to the ISDN BC-IE parameter values "inband negotiation possible" and "user rate indicated by E-bits specified in ITU-T Recommendation I.460 or may be negotiated inband" (octet 5a of ISDN BC-IE). In case of data compression high speed modems, like V.32bis, V.34 and/or V.90 may be used in the IWF. Autobauding may also be used to support user rates less than 9.6 kbit/s towards the PSTN.

NOTE 11: The ITC value of the PLMN BC-IE "speech", "3,1 kHz audio Ex PLMN" will indicate these requirements.

NOTE 12: For the use of NIRR see 3G TS 27.001.

NOTE 13: The value of the Intermediate Rate field of the ISDN Bearer Capability information element shall only depend on the values of the User Rate and the Information Transfer Capability in the same information element. The correspondence is:

Intermediate Rate = not used if User Rate > than 19.2 kbit/s.
 Intermediate Rate = 32 kbit/s if User Rate = 19,2 kbit/s or 14.4 kbit/s.
 Intermediate Rate = 16 kbit/s if User Rate = 9,6 kbit/s.
 Intermediate Rate = 8 kbit/s otherwise.

In case of Audio calls the value of the Intermediate Rate may be set to "not used".

NOTE 14: If compression is supported by the MSC and "data compression allowed" is indicated, then the ISDN user rate for UDI calls shall be set as follows. If the parameter "FNUR" is present the ISDN user rate shall be set to this value. Otherwise the PLMN user rate shall be mapped to an equal or any higher ISDN user rate value (in case of V.110 the highest ISDN user rate shall be 19,2 kbit/s). The Intermediate Rate shall be set to an appropriate value.(see subclause 10.2.4.11).

In case of "3,1 kHz audio" the modem shall try to negotiate data compression and flow control (see subclause 9.2.4.11). In case of "autobauding type 1" high speed modems may be used (see note 10).

NOTE 15: User rate of the PLMN -BC is overridden by the fixed network user rate of the PLMN BC-IE if available. When the MT indicates „autobauding“, „modem for undefined interface“ or „none“, the other modem type shall be set to „no other modem type“; any other value of the modem type is overridden by the other modem type value (see 3G TS 27.001). In UMTS, if octet 6d is not present in the PLMN BC, the MSC shall reject the call. The support of user rates lower than 9.6 kbit/s in UMTS are only possible in the scope of autobauding (see note 10).

NOTE 16: The ISDN-BC will consist of the octets 1 to 4 only, coded:

Coding standard:	CCITT
Information Transfer capability:	UDI
Transfer mode:	circuit
Information transfer rate:	64 kbit/s

NOTE 17: V.120 interworking is selected.

If an LLC element is not present, the network will insert an LLC. If an LLC is present it may be modified. The PLMN -BC parameters negotiated with the MS shall be mapped to the LLC parameters. The LLC parameter Rate Adaptation will be set to "V.120".

When interworking with unrestricted 64 kbit/s networks the ISDN BC shall be coded according to note 16.

NOTE 18: When the MSC is directly connected to a restricted 64 kbit/s network, the ISDN BC-IE is coded with an ITC = RDI.

When indirectly interworking with a restricted 64 kbit/s network the ISDN BC-IE shall be coded according to ETR 018, as shown below:

Coding standard:	CCITT
Information Transfer capability:	UDI
Transfer mode:	circuit
Information transfer rate:	64 kbit/s
User information layer 1 protocol:	V.110/X.30
Synchronous/Asynchronous:	synchronous
Negotiation:	In-band negotiation not possible
User rate:	56 kbit/s

If an LLC element is not present, the network will insert an LLC. If an LLC is present it may be modified. The PLMN -BC parameters negotiated with the MS shall be mapped to the LLC parameters according to the rules in this table. The LLC parameter Information Transfer Capability will be set to „restricted digital“

NOTE 19: In case the MS signals an ACC containing TCH/F4.8 only and the network does not support TCH/F4.8 channel coding, then the MSC may act as if TCH/F9.6 were included in the ACC.

NOTE 20: Extension of the 'Acceptable channel codings' field in octet 6e in case EDGE channel codings are supported.

NOTE 21: Only applicable for bit transparent 56 and 64 kbit/s services.

NOTE 22: Only applicable for non-transparent services.

NOTE 23: This parameter shall be included if EDGE channel codings are indicated in ACC. In cases where this parameter would not otherwise be included, the value is set to 'Air interface user rate not applicable' or 'User initiated modification not requested' or 'No preference'.

NOTE 24: This value was used by services defined for former GSM releases and does not need to be supported.

NOTE 25: The case of FTM is identified by Rate adaptation in the PLMN BC-IE set to "CCITT X.31 flag stuffing", Connection element set to "non-transparent", and Synchronous/asynchronous set to "asynchronous". The parameter values shall be set according to Note 16 in case FNUR is 64 kbit/s and according to Note 18 if Other ITC is RDI.

NOTE 26: In the case FNUR=64 kbit/s the ISDN BC-IE shall be coded as follows:

Coding standard:	ITU-T
Information Transfer capability:	UDI
Transfer mode:	circuit
Information transfer rate:	64 kbit/s
User information layer 1 protocol:	H.223 and H.245

In the case FNUR=56 kbit/s the ISDN BC-IE shall be coded as in note 18.

In the case FNUR=32 kbit/s the ISDN BC-IE shall be coded as follows:

Coding standard:	ITU-T
Information Transfer capability:	UDI
Transfer mode:	circuit
Information transfer rate:	64 kbit/s
User information layer 1 protocol:	V.110, I.460 & X.30
Synchronous/Asynchronous:	synchronous
Negotiation:	In-band negotiation not possible
User rate:	32 kbit/s

In the case FNUR=28.8 kbit/s the ISDN BC-IE shall be coded as follows:

Coding standard:	ITU-T
Information Transfer capability:	3,1 kHz Audio
Transfer mode:	circuit
Information transfer rate:	64 kbit/s
User information layer 1 protocol:	G.711 A-law or μ -law
Synchronous/Asynchronous:	synchronous
Negotiation:	In-band negotiation not possible
Modem type:	V.34
User rate:	28.8 kbit/s

In the case FNUR=33.6 kbit/s the ISDN BC-IE shall be coded as follows:

Coding standard:	ITU-T
Information Transfer capability:	3,1 kHz Audio
Transfer mode:	circuit
Information transfer rate:	64 kbit/s
User information layer 1 protocol:	G.711 A-law or μ -law

NOTE 27: In the case the FNUR=32 kbit/s the ISDN BC-IE shall be coded for PIAFS as follows:

Coding standard:	ITU-T
Information Transfer capability:	UDI
Transfer mode:	circuit
Information transfer rate:	64 kbit/s
User information layer 1 protocol:	V.110, I.460 and X.30
Synchronous/Asynchronous:	synchronous
Negotiation:	In-band negotiation not possible
User rate:	32 kbit/s

In the case of a FNUR=64 kbit/s the ISDN BC-IE shall be coded for PIAFS as in note 16.

Table 7B: Comparable setting of parameters in PLMN and ISDN: Mobile Terminated

Octet	ISDN BC parameter value	Octet	PLMN BC parameter value
1	Bearer Capability IEI	1	Bearer Capability IEI
2	Length of BC contents	2	Length of BC contents
	no comparable field	3 #7..6	Radio channel requirement (note 1) _half rate channel full rate channel (these bits are spare in the network to MS direction) both, half rate preferred both, full rate preferred
3 #7..6	Coding standard CCITT standardized coding	3 #5	Coding standard GSM standardized coding
3 #5..1	Information transfer capability speech unrestricted digital 3,1 kHz audio no comparable value no comparable value 7 kHz audio video (note 23)	3 #3..1	Information transfer capability speech unrestricted digital 3,1 kHz audio ex PLMN (note2) facsimile group 3 (note 3) other ITC (see octet 5a) not supported not supported
		5a #7..6	Other ITC restricted digital
4 #7..6	Transfer mode circuit mode packet mode	3 #4	Transfer mode circuit mode circuit mode
4 #5..1	Information transfer rate 64 kbit/s		no comparable field
	No comparable field	4 #7	Compression (note 18) data compression possible data compression not possible
	No comparable field (note 4)	(4) 4 #6..5	Structure (note 9) SDU integrity unstructured
4a #4..3	No comparable field (note 4)	4 #3	Configuration point-to-point (note 5)
	No comparable field	4 #2	NIRR (note 17) No meaning Data ≤ 4.8 kbit/s, FR nt, 6 kbit/s radio interface requested
4a #2..1	No comparable field (note 4)	4 #1	Establishment demand (note 5)
4b #7..6			
4b #5..1			

(continued)

Table 7B (continued): Comparable setting of parameters in PLMN and ISDN: Mobile Terminated

Octet	ISDN BC parameter value	Octet	PLMN BC parameter value
5 #5..1	User information layer 1 protocol no comparable value CCITT V.110, I.460 / X.30 G.711 A-law CCITT X.31 flag stuffing no comparable value No comparable value H.221 & H.242(note 28) H.223 & H.245	5 #5..4	Rate adaption no rate adaption (note 11) V.110, I.460/X.30 rate adaption no comparable value CCITT X.31 flag stuffing other rate adaption (see octet 5a)
		5a #5..4	Other rate adaptation V.120 (note 24) PIAFS H.223 & H.245 H.223 & H.245
	no comparable field	5 #3..1	Signalling access protocol I.440/I.450 X.21 X.28, ded.PAD, indiv.NUI (note 26) X.28, ded.PAD, univ.NUI (note 26) X.28, non-ded.PAD X.32
	see above	6 #5..2	User information layer 1 protocol default layer 1 protocol
5a #7	Synchronous / asynchronous synchronous asynchronous	6 #1	Synchronous/asynchronous synchronous asynchronous
5a #6	Negotiation not possible inband neg, possible (note 16)	6a #6	Negotiation not possible no comparable value

(continued)

Table 7B (continued): Comparable setting of parameters in PLMN and ISDN: Mobile Terminated

Octet	ISDN BC parameter value	Octet	PLMN BC parameter value
5a #5..1	User rate 0,3 kbit/s 1,2 kbit/s 2,4 kbit/s 4,8 kbit/s 9,6 kbit/s 12 kbit/s rate is indicated by Ebit as specified in rec. I.460 0,6 kbit/s 3,6 kbit/s 7,2 kbit/s 8 kbit/s 14,4 kbit/s 16 kbit/s 19.2 kbit/s 28.8 kbit/s 32 kbit/s 38.4 kbit/s 48 kbit/s 56 kbit/s 57,6 kbit/s 0,1345 kbit/s 0,1 kbit/s 75 bit/s / 1,2 kbit/s 1,2 kbit/s / 75 bit/s 0,110 kbit/s 0,2 kbit/s	6a #4..1	User rate (note 18 and 29) 0,3 kbit/s 1,2 kbit/s 2,4 kbit/s 4,8 kbit/s 9,6 kbit/s 12 kbit/s (note 13) (note 16) not supported not supported not supported not supported (note 20) not supported (note 20) (note 20) (note 20) (note 20) (note 20) (note 20) not supported not supported not supported not supported not supported not supported
5b #7..6	Intermediate rate not used (note 19) 8 kbit/s 16 kbit/s 32 kbit/s	6b #7..6	Intermediate rate (note 6) (note 18) 8 or 16 kbit/s 8 kbit/s 16 kbit/s
5b #5	NIC on Tx (note 14) does not require requires	6b #5	NIC on Tx does not require requires (note 13)
5b #4	NIC on Rx (note 14) cannot accept can accept	6b #4	NIC on Rx cannot accept can accept (note 13)
5b #3	Flow control on Tx (note 15) Not Required Required		no comparable field
5b #2	Flow control on Rx (note 15) Cannot Accept Accept		no comparable field
5c #7..6	Number of stop bits 1 bit 2 bits not used 1.5 bits	6a #7	Number of stop bits 1 bit 2 bits no comparable value not supported

(continued)

Table 7B (continued): Comparable setting of parameters in PLMN and ISDN: Mobile Terminated

Octet	ISDN BC parameter value	Octet	PLMN BC parameter value
5c #5..4	Number of data bits 7 bits 8 bits not used 5 bits	6a #5	Number of data bits 7 bits 8 bits no comparable value not supported
5c #3..1	Parity information odd even none forced to 0 forced to 1	6b #3..1	Parity information odd even none forced to 0 forced to 1
	no comparable field	6c #7..6	Connection element (note 1) transparent non-transparent (RLP) both, transp. preferred both, non-transp preferred
5d #7	Duplex mode half duplex full duplex	4 #4	Duplex mode half duplex (note 13) full duplex (note 5)
5d #6..1	Modem type reserved V.21 V.22 V.22bis V.23 V.26ter V.32 V.26 V.26bis V.27 V.27bis V.29 no comparable value	6c #5..1	Modem type (note 12) none (note 7) V.21 V.22 V.22bis not supported V.26ter V.32 not supported not supported not supported not supported not supported autobauding type 1 (note 16)
5a #5..1	User rate no comparable value 9,6 kbit/s 14,4 kbit/s 19,2 kbit/s 28,8 kbit/s 32,0 kbit/s 38,4 kbit/s 48 kbit/s 56 kbit/s no comparable value	6d #5..1	Fixed network user rate (note 20) FNUR not applicable 9,6 kbit/s 14,4 kbit/s 19,2 kbit/s 28,8 kbit/s 32,0 kbit/s (note 27) 38,4 kbit/s 48,0 kbit/s 56,0 kbit/s 64,0 kbit/s (note 22)
	Modem type no comparable value (note 21) V.34	6d #7..6	Other modem type No other modem type V.34

(continued)

Table 7B (concluded): Comparable setting of parameters in PLMN and ISDN: Mobile Terminated

Octet	ISDN BC parameter value	Octet	PLMN BC parameter value
	No comparable field	6f #7..5	User initiated modification indicator (note 1) (note 25) User initiated modification not required User initiated modification upto 1 TCH/F may be requested User initiated modification upto 2 TCH/F may be requested User initiated modification upto 3 TCH/F may be requested User initiated modification upto 4 TCH/F may be requested
6 #5..1	User information layer 2 protocol (note 10) Q.921 (I.441) X.25, link level no comparable value	7	User information layer 2 protocol (note 8) no comparable value X.25, link level ISO 6429, codeset 0
7	User information layer 3 protocol (note 10) Q.931 (I.451) X.25, packet level		not supported not supported

General notes:

- 1) Other ISDN BC parameter values than those listed in the table, if indicated in the BC-IE, will be rejected by clearing the call, exception see mapping note 4.
- 2) Only the PLMN BC parameter values listed in the table may be generated (comparable values) during a mobile-terminated call by mapping the ISDN BC parameter values, exception see (10).
- 3) According to Q.931 (05/98) and 3G TS 24.008, respectively, the octets are counted from 1 to n onwards; the bit position in a particular octet is indicated by #x..y, with {x,y} = 1..8 (bit 1 is the least and bit 8 the most significant bit).
- 4) If octets 5 to 5d of the ISDN BC are absent but present in the LLC, the LLC octets should apply for the mapping as indicated above. In the case of V.120 interworking (see note 24) these LLC octets shall apply.
- 5) If within the ISDN BC the parameters information transfer capability indicates "3,1 kHz audio" and user layer 1 protocol indicates "G711 A-law" or "G.711 μ -law" (PCS-1900) but no modem type is available and the HLC does not indicate "facsimile group 3", octets 5 to 5d of the LLC, if available, apply for the above mapping procedure.
- 6) The number of octets which shall be encoded for the PLMN BC-IE must comply to encoding rules in 3G TS 24.008 and the combination of the different parameter values shall be in accordance to 3G TS 27.001.

NOTES regarding the mapping:

- 1) This PLMN parameter value is inserted according to user rate requirements and network capabilities / preferences.
- 2) This PLMN parameter value is inserted, if the information transfer capability in ISDN BC is "3,1kHz audio" and a comparable modem type is specified.
- 3) This PLMN parameter value is inserted, if the information transfer capability is "3,1 kHz audio" and the content of the HLC-IE, if any, indicates "facsimile group 2/3", (for details refer to subclause 10.2.2 case 3 for HLR action and case 5 for VMSC action). Note that via MAP the value "alternate speech/facsimile group 3 - starting with speech" shall be used, when TS 61 applies.
- 4) When interworking with an ISDN according to ETS 300 102-1, octets 4a and 4b may be present. The values are ignored and PLMN values are set according to notes 5 and 9.
- 5) This PLMN parameter value is inserted if the comparable ISDN parameter value is missing.

- 6) The value of the Intermediate Rate field of the GSM Bearer Capability information element shall only depend on the values of the user rate ~~or the radio channel requirement~~ in the same information element. If the connection element is "transparent", the value is 16 kbit/s, if the user rate is 9.6 or 12 kbit/s, and 8 kbit/s otherwise. For any other connection element setting the value is 16 kbit/s; ~~if the radio channel requirements are "full rate" or "dual, full rate preferred", or "dual, half rate preferred", and 8 kbit/s, if the radio channel requirements is "half rate"~~.
- 7) This PLMN BC parameter value is inserted, if the PLMN BC parameter "Information Transfer Capability" indicates "Unrestricted digital information", "facsimile group 3" or "alternate speech/facsimile group 3, starting with speech".
- 8) Where the network indicates "asynchronous" and connection elements "non-transparent", "both, transparent preferred" or "both, non-transparent preferred", then the GSM BC should be forwarded without parameter user information layer 2 protocol, see also (10).
- 9) The PLMN parameter value shall be set to "unstructured" where the network indicates connection element "transparent". Where the network indicates connection elements "non transparent" "both, transparent preferred" or "both, non transparent preferred" the value of the parameter structure shall be set to "SDU Integrity".
- 10) Mapping of parameter values of this octet to PLMN BC parameters and values are subject to specific application rules, i.e. unless otherwise explicitly stated in an appropriate TS mapping to PLMN BC parameters shall not take place.
- 11) This value shall be used when the value of the PLMN BC parameter "Information Transfer Capability" indicates the value "3,1 kHz audio ex PLMN", "facsimile group 3" or "alternate speech/facsimile group 3, starting with speech" which is reserved for MAP operations.
- 12) The modem encoding of both Q.931 (05/98) and ETS 300 102-1 version 1 shall be accepted and mapped according to 3G TS 24.008.
- 13) Value not used for currently defined bearer services and Teleservices.
- 14) NIC is only supported in GSM for "3,1 kHz Ex PLMN audio" interworking with synchronous data transmission.
- 15) Because the required flow control mechanism can not be indicated to the MS (refer to 3G TS 27.001), the network shall check if the flow control mechanism selected by the MS and indicated in the CALL CONFIRMED message suits to the requirements requested by the ISDN terminal adaptor. In case of a mismatch the call shall be released in the IWF.

Because an asymmetric flow control mechanism (with respect to transmitting and receiving side) is not supported in the PLMN, the different values of the ISDN BC-IE parameters "flow control on Tx" and "flow control on Rx" shall be interpreted in the following way:

- "Flow control on Rx" set to "accepted" matches with "outband flow control", irrespective of the value of the parameter "flow control on Tx".
 - "Flow control on Rx" set to "not accepted" and "flow control on Tx" set to "not required" matches with "inband flow control" and "no flow control".
 - where "Flow control on Rx" is set to "not accepted" and "flow control on Tx" to "required" the call shall be released by the IWF.
- 16) If in case of 3,1 kHz audio interworking "inband negotiation possible" is indicated and the parameter user rate is set to "rate is indicated by E bits specified in Recommendation I.460 or may be negotiated inband" the user rate in the PLMN BC-IE shall be set according to a network preferred value; ~~whereas the preferred value of the Radio Channel Requirement shall be considered~~. If ISDN-BC parameter modem type is present, its value shall be ignored. The PLMN-BC parameter modem type shall be set according to the user rate in case of connection element "transparent" and to "autobauding type 1" in case of connection element "non transparent", "both, transparent preferred" or "both, non transparent preferred". In case of data compression high speed modems, like V.32bis, V.34 and/or V.90 may be used in the IWF. Autobauding may also be used to support user rates less than 9.6 kbit/s towards the PSTN.

For unrestricted digital interworking the call shall be rejected if these values are indicated. If the PLMN-BC parameter modem type indicates "autobauding type 1" or "none", then the PLMN-BC parameter other modem type shall be set to "no other modem type".

- 17) For the use of NIRR see 3G TS 27.001. The VMSC shall set this parameter dependent upon its capabilities and preferences.
- 18) If compression is supported by the MSC, the value "data compression possible" may be set. Depending on the capabilities of the MSC, the user rate value and the intermediate rate value is set to an appropriate value.
- 19) Only applicable if the parameter ISDN-BC ITC indicates "3,1 kHz audio" and for "UDI" calls if User Rate > "19,2 kbit/s".
- 20) The user rate of the PLMN BC is set to the value for the fall-back bearer service. In case the mobile station does not support the fixed network user rate (i.e. the call confirmation message does not contain the fixed network user rate parameter), the network may release the call for a transparent connection element.
- 21) The modem type parameter of the PLMN -BC is taken into account, only.
- 22) In case no LLC is received and the ISDN-BC received consists of octets 1 to 4 only, coded:

Coding standard:	CCITT
Information Transfer capability:	UDI
Transfer mode:	circuit
Information transfer rate:	64kbit/s

the following PLMN -BC parameters, shall be set to:

fixed network user rate:	64 kbit/s
connection element:	transparent bothNT or bothT (If IWF supports FTM or PIAFS)

The other parameters of the PLMN -BC shall be set to values indicating a fall-back service.

- 23) When the MSC is directly connected to a restricted 64 kbit/s network, the ISDN BC-IE is coded with an ITC = RDI.

An ISDN BC-IE, as specified in ETR 018 and shown below, shall be taken to indicate that interworking with an indirectly connected restricted 64 kbit/s network is required:

Coding standard:	CCITT
Information Transfer capability:	UDI
Transfer mode:	circuit
Information transfer rate:	64 kbit/s
User information layer 1 protocol:	V.110/X.30
Synchronous/Asynchronous:	synchronous
Negotiation:	In-band negotiation not possible
User rate:	56 kbit/s

In this case the PLMN BC parameter Information Transfer Capability is set to „Other ITC" and Other ITC parameter is set to „restricted digital". If ISDN LLC exists, all the corresponding fields in the PLMN BC shall be derived from the ISDN LLC. Otherwise, the corresponding fields in the UMTS BC shall be derived from the ISDN BC. In the above both case, Connection element is set as follows.

Connection element:	transparent bothNT or bothT (If IWF supports FTM)
---------------------	------------------------------------------------------

- 24) V.120 interworking is required if the ISDN LLC parameter User Information Layer 1 Protocol is set to „V.120". In this case the PLMN BC parameter Rate Adaptation is set to „Other rate adaptation" and Other Rate Adaptation parameter is set to „V.120". All the corresponding fields in the GSM BC shall be derived from the ISDN LLC.
- 25) This parameter is only included in case of non-transparent multislot connections.
- 26) This value was used by services defined for former GSM releases and does not need to be supported.

27) Following UMTS-BC parameters in SETUP message shall be set to:

Fixed network user rate	32 kbit/s
Connection element	transparent bothNT or bothT (If IWF supports PIAFS)

28) UIL1P is set to "H.221 & H.242" or "H.223 & H.245" by H.324/I. In the case where UIL1P is set to "H.221 and H.242", this should be mapped to "H.223 & H.245".

29) In UMTS, if the User Rate of the ISDN BC is less than 9,6 kbit/s and the Connection Element is mapped to "NT", then FNUR is fixed to 9,6 kbit/s.