

3GPP TSG_CN#6
Meeting #6, Nice, France
13th - 15th December 1999

NP-99575

Title: Stage 2 of the Location Services feature in UMTS, 23.171, v1.1.0

Source: Nokia

Agenda Item: 5.7.1

Document for: Information and discussion

TSG-SA WG2 #10, Japan
November 29th – December 3rd 1999

TSG S2-99D16

Agenda Item: [Location services in UMTS]

Source: Editor

Title: New version of 23.171, v1.1.0

Document for: Information/ decision confirmation

Summary:

This contribution contains version 1.1.0 of 23.171, which includes the changes and additions proposed in SA2#9 and agreed over E-mail 12.11.1999.

3G TS 23.171 1.1.0 (1999-11)

Technical Specification

3rd Generation Partnership Project; Technical Specification Group Services and System Aspects; Functional stage 2 description of location services in UMTS, (3G TS 23.171 version 1.1.0)



The present document has been developed within the 3rd Generation Partnership Project (3GPP™) and may be further elaborated for the purposes of 3GPP. The present document has not been subject to any approval process by the 3GPP Organisational Partners and shall not be implemented. This Specification is provided for future development work within 3GPP only. The Organisational Partners accept no liability for any use of this Specification. Specifications and reports for implementation of the 3GPP™ system should be obtained via the 3GPP Organisational Partners' Publications Offices.

Reference

DTS/TSGS-0122121U

Keywords

<UMTS, LCS>

3GPP

Postal address

3GPP support office address

650 Route des Lucioles - Sophia Antipolis
Valbonne - FRANCE
Tel.: +33 4 92 94 42 00 Fax: +33 4 93 65 47 16

Internet

<http://www.3gpp.org>

Contents

Foreword.....	6
1 Scope.....	7
2 References	7
2.1 Normative references	7
2.2 Informative references	8
3 Definitions and abbreviations.....	8
3.1 Definitions	8
3.2 Abbreviations.....	8
4 Main concepts.....	10
4.1 Assumptions.....	10
4.2 Location Services Categories.....	10
4.3 Positioning methods.....	11
4.3.1 Standard LCS Methods in UTRAN release 99.....	11
4.4 Location information sources, network interaction.....	11
5 General LCS architecture	12
5.1 LCS access interfaces and reference points	12
5.2 LCS Functional diagram, high level functions	12
5.3 LCS Client functional group.....	14
5.3.1 External Location Client Function (LCF).....	14
5.3.2 Internal Location Client Function U-LCF).....	14
5.4 LCS Server functional group in UMTS	14
5.4.1 Client handling component.....	14
5.4.2 System handling component.....	15
5.4.3 Subscriber handling Component	16
5.4.4 Positioning components	16
5.5 Information Flows between Client and Server.....	16
5.5.1 Location Service Request.....	17
5.5.2 Location Service Response	17
6 UMTS LCS Architecture.....	17
6.1 Schematic functional description of LCS operations in UMTS	18
6.2 Allocation of LCS functions to UMTS network elements	19
6.3 Functional description of LCS per network element.....	21
6.3.1 Access Network.....	21
6.3.2 LCS Clients and LCS applications	21
6.3.3 Gateway Mobile Location Center, GMLC	21
6.3.4 Serving RNC, UTRAN case.....	22
6.3.5 LCS support in the Mobile Station.....	22
6.3.6 LMU.....	22
6.3.7 3G-MSC/VLR.....	22
6.3.8 3G-SGSN	22
6.3.9 Home Location Register, HLR.....	22
6.3.10 gsmSCF.....	22
6.4 Addressing the target UE for LCS purposes	22
7 Signaling Protocols and Interfaces	23
7.1 Signalling protocols for LCS support in UMTS	23
7.2 Iu interface.....	23
7.2.1 Information Flows between UTRAN and the Core Network	23
7.2.2 Location Report.....	24
7.3 Iur Interface, Signaling between RNCs.....	24
7.4 Uu Interface	24
7.4.1 MAP Interfaces	24

8	General network location procedures	25
8.1	State description for GMLC.....	25
8.1.2	State Functionality.....	26
8.2	State description for 3G-VMSC/VLR.....	27
8.2.1	3G-VMSC States.....	27
8.2.2	State Functionality.....	27
8.3	LCS State description for 3G-SGSN	28
8.3.1	3G-SGSN States.....	28
8.3.2	State Functionality.....	28
8.4	State description for RNC in UTRAN	29
8.5	General Network Positioning Procedures	29
8.6	Mobile Terminating Location Request	29
8.6.1	Circuit Switched Mobile Terminating Location Request (CS-MT-LR)	29
8.6.2	MT-LR for a previously obtained location estimate.....	32
8.6.3	Network Induced Location Request (NI-LR)	34
8.6.4	Network Induced Location Request (NI-LR) from a Serving RNC for a target UE in dedicated mode.....	36
8.7	Mobile Originating Location Request.....	37
8.7.1	Mobile Originating Location Request, Circuit Switched (CS-MO-LR)	37
9	Information storage.....	40
9.1	HLR	40
9.1.1	LCS Data in the HLR for an UE Subscriber	40
9.2	VLR	40
9.3	GMLC.....	40
9.4	Recovery and Restoration Procedures	40
10	Operational Aspects.....	40
10.1	Charging	40
10.1.1	Charging Information collected by the PLMN serving the LCS Client.....	40
10.1.2	Charging Information Collected by the Visited PLMN.....	40
11	History	40
	DEFINITIONS and terms ANNEX 1.....	41

Foreword

This Technical Specification has been produced by the 3GPP.

The contents of the present document are subject to continuing work within the TSG and may change following formal TSG approval. Should the TSG modify the contents of this TS, it will be re-released by the TSG with an identifying change of release date and an increase in version number as follows:

Version x.y.z

where:

- x the first digit:
 - 1 presented to TSG for information;
 - 2 presented to TSG for approval;
 - 3 Indicates TSG approved document under change control.
- y the second digit is incremented for all changes of substance, i.e. technical enhancements, corrections, updates, etc.
- z the third digit is incremented when editorial only changes have been incorporated in the specification;

1 Scope

This document specifies the stage 2 of the LoCation Services (LCS) feature in UMTS, which provides the mechanisms to support mobile location services for operators, subscribers and third party service providers.

Location Services may be considered as a network provided enabling technology consisting of standardised service capabilities, which enable the provision of location applications. The application(s) may be service provider specific. The description of the numerous and varied possible location applications which are enabled by this technology are outside the scope of this specification. However, clarifying examples of how the functionality being described may be used to provide specific location services may be included.

This stage 2 service description covers the LCS system functional model for the whole system, the LCS system architecture, state descriptions, message flows, etc.

2 References

References may be made to:

- a) Specific versions of publications (identified by date of publication, edition number, version number, etc.), in which case, subsequent revisions to the referenced document do not apply; or
- b) All versions up to and including the identified version (identified by "up to and including" before the version identity); or
- c) All versions subsequent to and including the identified version (identified by "onwards" following the version identity); or
- d) Publications without mention of a specific version, in which case the latest version applies.

A non-specific reference to an ETS shall also be taken to refer to later versions published as an EN with the same number.

2.1 Normative references

- [1] 3G TR 25.305: "Functional stage 2 specification of location services in UTRAN"
- [2] GSM 01.04 (ETR 350): "Abbreviations and acronyms"
- [3] [reserved for UMTS abbreviations and acronyms]
- [4] 3G TS 22.071: "Location Services (LCS); Service description, Stage 1"
- [5] GSM 03.71: "Location Services (LCS); (Functional description) - Stage 2"
- [6] GSM 03.32: "Universal Geographical Area Description"
- [7] 3G TS 22.100: "UMTS phase 1 Release 99"
- [8] 3G TS 22.101: " Service principles"
- [9] 3G TS 22.105: " Services and Service Capabilities"
- [10] 3G TS 22.115: "Charging and Billing"
- [11] 3G TS 22.121: "The Virtual Home Environment"
- [12] 3G TS 23.110: "UMTS Access Stratum; Services and Functions"
- [13] PD 30.lcs: "Project Plan for location services in UMTS"

- [14] TS 25.413: "UTRAN Iu Interface RANAP signalling"
- [15] TS 23.060: "General Packet Radio Service (GPRS); Service description; Stage 2"

2.2 Informative references

- [16] Third generation (3G) mobile communication system; Technical study report on the location services and technologies, ARIB ST9 December 1998.
- [17] The North American Interest Group of the GSM MoU ASSOCIATION: Location Based Services, Service Requirements Document of the Services Working Group

3 Definitions and abbreviations

3.1 Definitions

The following terms are defined in Annex 1:

CAMEL
 Current Location
 Deferred location request
 Global Positioning System (GPS)
 Immediate location request
 Initial Location
 Last Known Location
 LCS (LoCation Services)
 LCS Client
 LCS Client Access barring list
 LCS Client Subscription Profile
 LCS Feature
 LCS Server
 Local Service
 Local Information
 Location (Based) Application
 Location Based Service (LBS)
 Location Dependent Service
 Location Estimate
 Location Independent Service
 Mobile Station (UE)
 PLMN Access barring list
 Positioning (/location detecting)
 Positioning method (/locating method)
 Positioning technology (/locating technology)
 Predefined area
 Privacy Class
 Privacy Exception List
 Prohibited area
 Subscription Profile
 Target UE
 ...
 Further UMTS related definitions are given in 3G TS 22.101.

3.2 Abbreviations

For the purposes of this TS the following abbreviations apply:

3G-MSC	3rd Generation MSC
3G-SGSN	3rd Generation SGSN
AC	Admission Control
AI	Application Interface (prefix to interface class method)
ARIB	Association of Radio Industries and Business
ATD	Absolute Time Difference
BCCH	Broadcast Control Channel
BER	Bit Error Rate
BS	Base Station
BSS	Base Station Subsystem
CAMEL	Customised Application For Mobile Network Enhanced Logic
CAP	CAMEL Application Part
CM	Connection Management
CN	Core Network
CSE	Camel Service Environment
DL	Downlink
DRNC	Drift RNC
E-OTD	Enhanced Observed Time Difference
FER	Frame Error Rate
GGSN	Gateway GPRS Support Node
GMLC	Gateway MLC
GPRS	General Packet Radio System
GPS	Global Positioning System
HE	Home Environment
HLR	Home Location Register
HPLMN	Home Public Land Mobile Network

IMEI	International Mobile Equipment Identity	PRCF	Positioning Radio Coordination Function
IUEI	International Mobile Subscriber Station Identity	PRRM	Positioning Radio Resource Management
IP	Internet Protocol	PSE	Personal Service Environment
IPDL	Idle Period DownlinkIWU Interworking Unit	PSMF	Positioning Signal Measurement Function
LA	Location Application	PSTN	Public Switched Telephone Network
LAF	Location Application Function	QoS	Quality of Service
LBS	Location Based Services	RA	Routing Area
LCAF	Location Client Authorization Function	RACH	Random Access Channel
LCCF	Location Client Control Function	RAN	Radio Access Network
LCCTF	Location Client Coordinate Transformation Function	RANAP	Radio Access Network Application Part
LCF	Location Client Function	RIS	Radio Interface Synchronization
LCS	LoCation Services	RNC	Radio Network Controller
LDR	Location Deferred Request	RRM	Radio Resource Management
LIR	Location Immediate Request,	RTD	Real Time Difference
LMU	Location Measurement Unit	SAT	SIM Application Tool-Kit
LSAF	Location Subscriber Authorization Function	SGSN	Serving GPRS Support Node
LSBF	Location System Billing Function	SI	Service Interface (prefix to interface class method)
LSCF	Location System Control Function	SIM	Subscriber Identity Module
LSOF	Location System Operation Function	SMS	Short Message Service
LSPF	Location Subscriber Privacy Function	SIR	Signal Interference Ratio
MAP	Mobile Application Part	SP	Service Point
ME	Mobile Equipment	SRNC	Serving RNC
MExE	Mobile Station (Application) Execution Environment	SS7	Signalling System No 7
MLC	Mobile Location Center	TA	Timing Advance
MM	Mobility Management	TMSI	Temporary Mobile Subscriber Identity
MO-LR	Mobile Originated Location Request	TOA	Time Of Arrival
UE	Mobile Station	U-.....	UMTS-(LCS functional block)
MSC	Mobile services Switching Centre	UE	User Equipment
MSISDN	Mobile Station Integrated Services Data Network	UL	Uplink
MT-LR	Mobile Terminated Location Request	UMTS	Universal Mobile Telecommunication System
NI-LR	Network Induced Location Request	USIM	User Service Identity Module
OSA	Open Service Architecture	UTRAN	Universal Terrestrial Radio Access Network
OTDOA	Observed Time Difference Of Arrival	VASP	Value Added Service Provider
PC	Power Control	VHE	Virtual Home Environment
PCF	Power Calculation Function	WCDMA	Wideband Code Division Multiple Access
PLMN	Public Land Mobile Network		

Further GSM related abbreviations are given in GSM 01.04. Further UMTS related abbreviations are given in UMTS TS 22.101.

4 Main concepts

A general description of location services and service requirements are given in the specification 3G TS 22.071 [4]. The positioning of the UE is a service provided by the UMTS Access Stratum. In particular, all Access Networks (e.g. UTRAN, GSM BSS), that facilitate determination of the locations of User Equipments, shall be able to exchange location information with the UMTS core network as defined in this specification (when connected to a UMTS Core Network).

By making use of the radio signals the capability to determine the (geographic) location of the user equipment (UE) mobile station shall be provided. The location information may be requested by and reported to a client (application) associated with the UE, or by a client within or attached to the Core Network. The location information may also be utilised internally by UMTS, for example, for location assisted handover or to support other features such as home location billing. The position information shall be reported in standard, i.e. geographical co-ordinates, together with the time-of-day and the estimated errors (uncertainty) of the location of the UE.

It shall be possible for the majority of the UE (active or idle) within a network to use the feature without compromising the radio transmission or signalling capabilities of the UMTS.

The uncertainty of the location measurement shall be network design (implementation) dependent at the choice of the network operator, this is further described in TS 25.305 [1].

There are many different possible uses for the location information. The positioning feature may be used internally by the UMTS network (or attached networks), by value-added network services, by the UE itself or through the network, and by “third party” services. The positioning feature may also be used by an emergency service (which may be mandated or “value-added”), but the position service is not exclusively for emergencies.

4.1 Assumptions

As a basis for the development work on LCS in UMTS the following assumptions apply:

1. Positioning methods are Access Network specific, although commonalities should be encouraged between Access Networks.
2. Commercial location services are only applicable for an UE with a valid SIM or USIM.
3. The provision of the location services in the Access Network is optional through support of the specified method(s).
4. The provision of location services is optional in 3G-MSC and 3G-SGSN.
5. LCS is applicable to any target UE whether or not the UE supports LCS, but with restrictions on choice of positioning method or notification of a location request to the UE user when LCS or individual positioning methods, respectively, are not supported by the UE.
6. LCS shall be applicable for both circuit switched and packet switched services.
7. The location information may be used for internal system operations to improve system performance.
8. It shall be possible to accommodate future techniques of measurement and processing to take advantage of advancing technology so as to meet new service requirements.
9. It shall be used for LCS signalling, even in the case when the RNSs are connected to different 3G-MSCs or 3G-SGSNs

4.2 Location Services Categories

Generally there are four categories of usage of the location service. These are the Commercial LCS, the Internal LCS,

the Emergency LCS and the Lawful Intercept LCS. The definition of these services and their categories is outside the scope of this document.

- The **Commercial LCS** (or **Value Added Services**) will typically be associated with an application that provides a value added service through knowledge of the UE location to the subscriber of the service. This may be, for example, a directory of restaurants in the local area of the UE together with directions for reaching them from the current UE location.
- The **Internal LCS** will typically be developed to make use of the location information of the UE for Access Network internal operations. This may include, for example, location assisted handover and traffic and coverage measurement. This may also include support certain O&M related tasks, supplementary services, IN related services and GSM bearer services and teleservices.
- The **Emergency LCS** will typically be part of a service provided to assist subscribers who place emergency calls. In this service, the location of the UE caller is provided to the emergency service provider to assist them in their response. This service may be mandatory in some jurisdictions. In the United States, for example, this service is mandated for all mobile voice subscribers.
- The **Lawful Intercept LCS** will use the location information to support various legally required or sanctioned services.

4.3 Positioning methods

The LCS feature utilises one or more positioning methods in order to determine the location of user equipment (UE). Determining the position of a UE involves two main steps:

Radio signal measurements and

Position estimate computation based on the measurements.

The positioning methods for UTRAN are further described in [1].

4.3.1 Standard LCS Methods in UTRAN release 99

The specification 25.305 UTRAN Stage 2 specifies the locating methods to be supported in Release 99:

- *Cell coverage based positioning method;*
- *OTDOA positioning method*
- *network assisted GPS positioning methods.*

For more details on these positioning methods, refer to [1].

4.4 Location information sources, network interaction

The location service design should not be limited to a single technique or source of information. As operating conditions vary both within and between networks, the LCS design should be able to make use of as many measurements and techniques as are available and are appropriate for the needs of (and the cost of) the service being provided.

The location process shall include the option to include all of the available UTRAN signals, including those from other networks with coverage available to the UE. While it should not be necessary for the UE to access these other networks, the UE and the location process should be able to make use of the signals from these sources in addition to those of the serving network. It should be noted that the UE does not need to access a foreign network in order to make measurements of the downlink signals.

It is critical to positioning accuracy that as many measurements are used as possible. This is particularly important in regions where the serving operator may provide coverage with only a single base station. Typically there will be additional coverage of these regions by other operators, but perhaps only from one base station from each operator. By making measurements of the signals from several operators the UE will typically be able to obtain information to make a better location estimate than would be possible with just the signals from a single operator (assuming that the base

stations are not colocated). The use of signals and other information from several operators would, of course, be subject to suitable operator agreement.

In some cases the UE may be able to operate in other modes (e.g. GSM) for which a location service feature is also provided. The signals of the other mode and location information may be helpful to the UTRAN LCS. For example, measurements of the GSM signals may be used by the UTRAN LCS calculation function to supplement the UTRAN radio measurements. The use of this information would, of course, be subject to suitable operator agreements. The techniques for this inter-mode operation and any signalling between networks are FFS.

The LCS information sources and the signalling required for their interaction, are FFS.

5 General LCS architecture

5.1 LCS access interfaces and reference points

There is one reference point between the LCS server and LCS client called Le, see Figure 5.1. Le is described in TS 22.071 [4], however the protocol specifics are for further study. There may be more than a single LCS network interface to several different LCS clients or other networks. These networks may both differ in ownership as well as in communications protocol. The network operator should define and negotiate interconnect with each external LCS client or other network.

An interface differs from a reference point in that an interface is defined where specific LCS information is exchanged and needs to be fully recognized.

There is an interface called Lg that connects two independent LCS networks (different PLMNs) for message exchange.

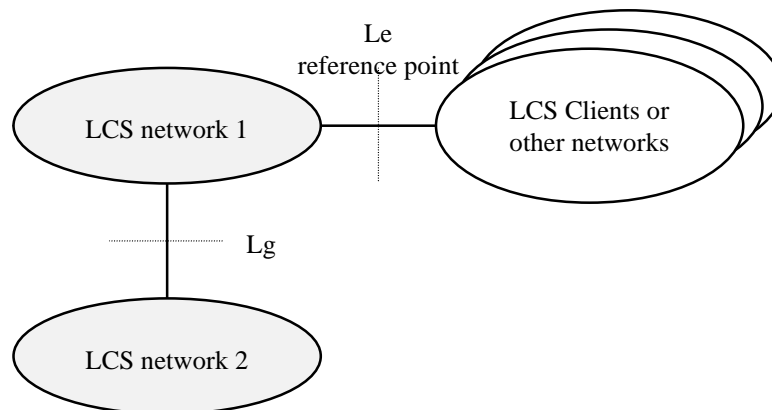

Figure 5.1, LCS Access Interfaces and Reference Points

5.2 LCS Functional diagram, high level functions

TS 22.071 [4] describes LCS services from the LCS client point of view. In this specification, a more detailed description of LCS is given. The LCS functional diagram shown in Figure 5.2 depicts the interaction of the LCS client and the LCS server within the PLMN. The PLMN uses the various LCS components within the LCS server to provide the target UE Location Information to the LCS client.

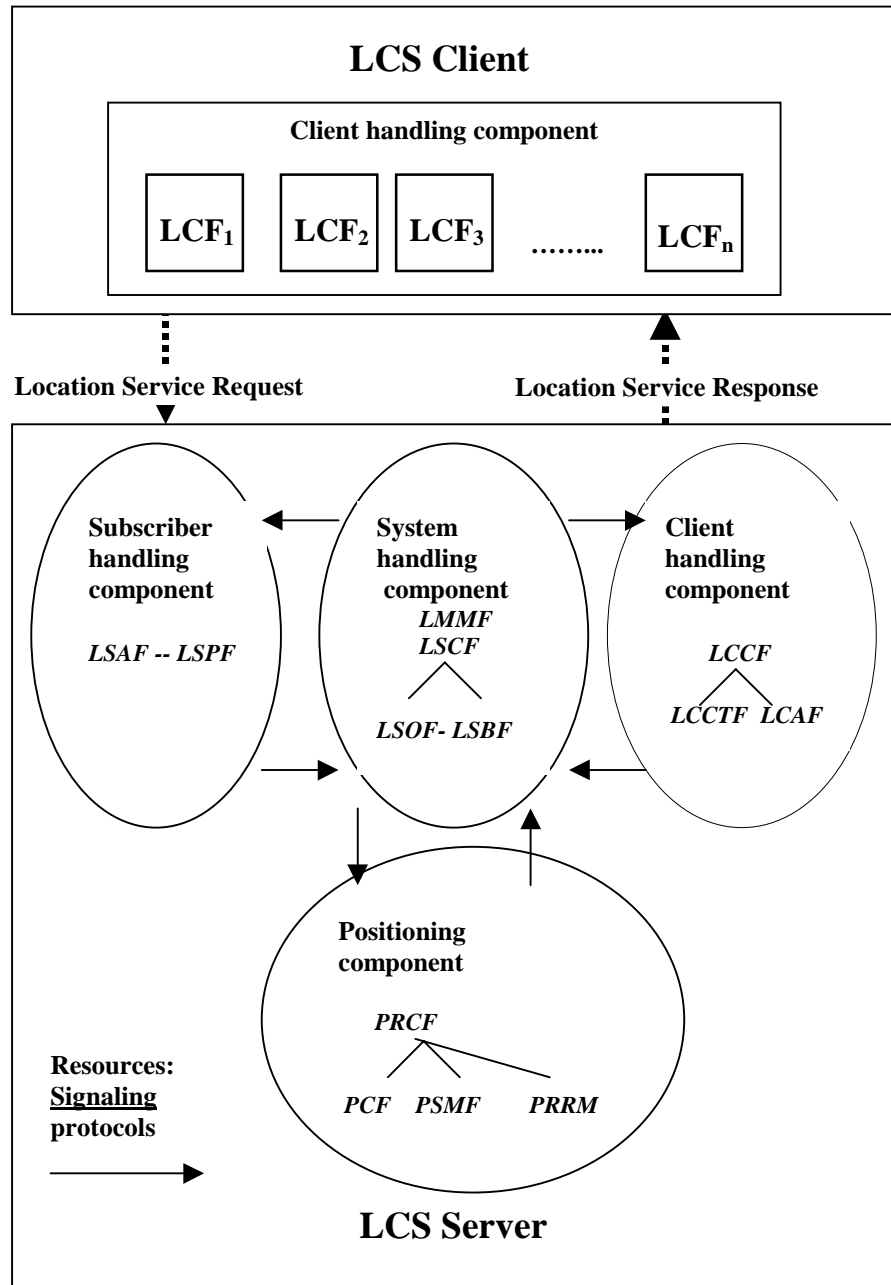

Figure 5.2, UMTS LCS capability server Functional Diagram

The following list gives the logical functional entities for the LCS. Two main functional groupings are defined which encompass a number of smaller functions.

The LCS Functional entities are grouped as follows :

- The LCS Client functional group
- The LCS Server functional group consists of functions in the UMTS PLMN supporting LCS:
 - Client handling component
 - System handling component
 - Subscriber handling Component
 - Positioning component

The functions of the LCS Client and the LCS Server in UMTS PLMN are described in more detail in this chapter. The allocation of LCS functions to UMTS network elements is specified in chapter 6.

5.3 LCS Client functional group

An LCS client contains an LCS component with one or more client(s) which by using location information can provide location based services.

An LCS client is a logical functional entity that requests from the LCS server in the PLMN location information for one or more than one target UE within a specified set of parameters such as Quality of Service (QoS). The LCS Client may reside in an entity (including the UE) within the PLMN or in an entity external to the PLMN.

The specification of the LCS Client's internal logic and its relation to the external use is outside the scope of this document.

5.3.1 External Location Client Function (LCF)

The Location Client Function (LCF) provides a logical interface between the LCS client and the LCS server.

This function is responsible for requesting location information for one or more MEs/UEs, with a specified "QoS" and receiving a response, which contains either location information or a failure indicator.

[Editor's note: this is only possible if the location request originates in the core network]

5.3.2 Internal Location Client Function U-LCF)

The Location Client Function (LCF) provides a logical interface between the internal ACCESS NETWORK LCS applications and the ACCESS NETWORK LCS system handling entities (e.g. the *Location System Control Function (U-LSCF)* in the ACCESS NETWORK). This interface may be internal to one network element.

The ACCESS NETWORK may make use of location information for internal operations such as location assisted handover. In such a case, a U-LCF representing the internal ACCESS NETWORK LCS application may communicate with the U-LSCF to request and receive the location information.

For UTRAN, this interface is further described in [1].

5.4 LCS Server functional group in UMTS

The LCS server functional group consists of the UMTS functions, that are needed for UMTS to support Location Services.

5.4.1 Client handling component

5.4.1.1 Location Client Control Function (LCCF)

The Location Client Control Function (LCCF) manages the external interface towards LCF. The LCCF identifies the LCS client by requesting client verification and authorization (i.e. verifies that the LCS client is allowed to position the subscriber) through interaction with the Location Client Authorization Function (LCAF) . The LCCF handles mobility management for location services (LCS) e.g., forwarding of positioning requests to 3G-VMSC. The LCCF determines if the final positioning estimate satisfies the QoS for the purpose of retry/reject. The LCCF provides flow control of positioning requests between simultaneous positioning requests. It may order the Location Client Coordinate Transformation Function (LCCTF) to perform a transformation to local coordinates. It also generates charging and billing related data for LCS via the Location System Billing Function (LSBF).

5.4.1.2 Location Client Authorization Function (LCAF)

The Location Client Authorization Function (LCAF) is responsible for providing access and subscription authorization to a client. Specifically, it provides authorization to a LCS client requesting access to the network and authorizes the

subscription of a client. LCAF provides authorization to a LCS client requesting Location Information of a specific UE.

5.4.1.2.1 Access Subfunction

An *Access Subfunction* enables LCS clients to access LCS services. This subfunction provides verification and authorization of the requesting client.

When a LCS is requested, the Access Subfunction uses the information stored in the LCS client *subscription profile* to verify that:

- the LCS client is registered; and
- the LCS client is authorized to use the specified LCS request type;
- the LCS client is allowed to request location information for the subscriber(s) specified in the LCS request;

5.4.1.2.2 Subscription Subfunction

The LCS client Subscription profile shall contain a minimum set of parameters assigned on per LCS client basis for an agreed contractual period. The LCS client profile shall contain the following set of access parameters:

- LCS client identity;
- Allowed LCS request types (i.e. LIR, LDR or both); see note
- Maximum number of subscribers allowed in a single LCS request;
- Priority;
- Position override indicator;
- State(s) ;
- Event(s) (applicable to LDR requests only);
- Local coordinate system;
- LCS client access barring list (optional);
- PLMN access barring list applicability ;

Note: LIR =Location Immediate Request ; and LDR= Location Deferred Request

For certain authorized LCS client internal to the PLMN, a subscription profile is unnecessary. These clients are empowered to access any defined service that is not barred for an UE subscriber. This permits positioning of emergency calls without the need for pre-subscription.

5.4.1.3 Location Client Coordinate Transformation Function (LCCTF)

The Location Client Coordinate Transformation Function (LCCTF) provides conversion of a location estimate expressed according to a universal latitude and longitude system into an estimate expressed according to a local geographic system understood by the LCF and known as location information. The local system required for a particular LCF will be either known from subscription information or explicitly indicated by the LCF.

5.4.2 System handling component

5.4.2.1 Location System Control Function in general (LSCF)

The Location System Control Function (LSCF) is responsible for coordinating location requests. This function manages call-related and non-call-related positioning requests of LCS and allocates network resources for handling them. The LSCF retrieves UE classmark for the purpose of determining a positioning method. The LSCF performs call setup if required as part of a LCS e.g., putting the ME on dedicated radio resources. It also caters for coordinating resources and activities with regard to requests related to providing assistance data needed for positioning. This function interfaces with the LCCF, LSPF, LSBF and PRCF. Using these interfaces, it conveys positioning requests to the PRCF, relays positioning data to the LCCF and passes charging related data to the LSBF.

5.4.2.2 Access Network Location System Control Function(U-LSCF)

The Access Network Location System Control Function is responsible for co-ordinating location requests. This function

manages call-related and non-call-related location requests and allocates network resources for handling them. This function “insulates” the Location clients in the Core Network from the detailed operation of the location method in order that the Access Network may be used by several types of core network and with several location methods.

The U-LSCF for UTRAN is further described in [1].

5.4.2.3 Location System Billing Function (LSBF)

The Location System Billing Function (LSBF) is responsible for charging and billing activity within the network related to location services (LCS). This includes charging and billing of both clients and subscribers. Specifically, it collects charging related data and data for accounting between PLMNs.

5.4.2.4 Location System Operations Function (LSOF)

The Location System Operations Function (LSOF) is responsible for provisioning of data, positioning capabilities, data related to clients and subscription (LCS client data and UE data), validation, fault management and performance management of UMTS LCS.

An LSOF may be associated with each entity.

[Editor's note: This is being studied in GSM. FFS in UMTS. Internal LCF may be part of O&M functions.]

5.4.3 Subscriber handling Component

5.4.3.1 Location Subscriber Authorization Function (LSAF)

The Location Subscriber Authorization Function (LSAF) is responsible for authorizing the provision of a location service (LCS) for a particular mobile station (UE with SIM/USIM). Specifically, this function validates that a LCS can be applied to a given subscriber. In case LCF is in the UE then LSAF verifies that the UE subscriber has subscribed to the requested LCS service.

5.4.3.2 Location Subscriber Privacy Function (LSPF)

The Location Subscriber Privacy function is responsible performs all privacy related authorizations. For an target UE it shall authorize the positioning request versus the privacy options of the target UE, if any.

5.4.4 Positioning components

The positioning components UMTS Access Network - Positioning Radio Coordination Function (U-PRCF), UMTS ACCESS NETWORK Positioning Calculation Function (U-PCF), UMTS Access Network - Positioning Signal Measurement Function (U-PSMF) and UMTS Access Network - Positioning Radio Resource Management (U-PRRM) are described documents specific to each Access Network type.

These entities are defined for UTRAN in [1].

5.5 Information Flows between Client and Server

[Editor's note: this formal description of the information flow between Client and Server was accidentally removed (renamed to Iu information flow) in the R2 September meeting. The text below is taken from 03.71 with the additions agreed in R2 in September, but split up in LCS request and LCS response information.]

Other types of national specific information flows may be supported in addition to the information flow specified here.

Any of the information flows here indicated may not be externally realized if the information does not flow over an open interface. On the other hand, if a flow goes over an open interface, it shall abide to a well-defined protocol, which will be further specified in other relevant specifications.

5.5.1 Location Service Request

Via the Location Service Request, the LCS client communicates with the LCS server to request for the location information of one or more than one UE within a specified quality of service. There exist two types of location service requests:

- Location Immediate Request (LIR); and
- Location Deferred Request (LDR).

The following attributes are identified for Location Service Request information flow:

[Editor's note: This list is subject to further review and the listed attributes should be defined.]

- Target UE ;
- [Indication what could be the achievable accuracy for the Target UE, generated based on UE capabilities and radio conditions, this attribute probably can be replaced by "Requested QoS", this is ffs.]
- LCS identity;
- State (idle, dedicated);
- Event (applicable to LDR requests only);
- Requested Quality of Service information;
- Local coordinate reference system;
- Geographical area, [should be checked with the meaning of "Geographical area" in 03.71.]

5.5.2 Location Service Response

The Location Service Response is sent to the LCS client as the result of the Location Service Request by the LCS Server:

- Immediate Response; and
- Deferred Response;

These deferred responses can be either single or periodic.

The following attributes are identified for the Location Service Response information flow:

[Editor's note: This list is subject to further review and the listed attributes should be defined.]

- Location indication of UE in geographical coordinates
- Location of UE as an ellipsoid with axes and direction of all axis
- Estimated achieved QoS;
- Indication when UE enters or leaves the Geographical area.

Some information attributes may be common and repeated for the location service request and location service response, such as Target UE, LCS identity, State, Event, Local co-ordinate system, geographical area.

6 UMTS LCS Architecture

Figure 6.1 shows the general arrangement of the Location Service feature in UMTS. This illustrates, generally, the relation of LCS Clients and servers in the core network with the UMTS Access Network. The LCS entities within the Access Network communicate with the Core Network (CN) across the Iu interface. Communication among the Access Network LCS entities makes use of the messaging and signalling capabilities of the Access Network.

As part of their service or operation, the LCS Clients may request the location information of user equipment UE (UE without a valid SIM/USIM) or mobile stations. There may be more than one LCS client. These may be associated with the UMTS network or the Access Network, operated as part of a UE application or accessed by the UE through its access to an application (e.g. through the Internet).

The clients make their requests to an LCS Server. There may be more than one LCS Server. The client must be

authenticated and the resources of the network must be co-ordinated including the UE and the calculation functions, to estimate the location of the UE and result returned to the client. As part of this process, information from other systems (other Access Networks) can be used. As part of the location information returned to the client, an estimate of the accuracy of the estimate and the time-of-day the measurement was made shall be provided.

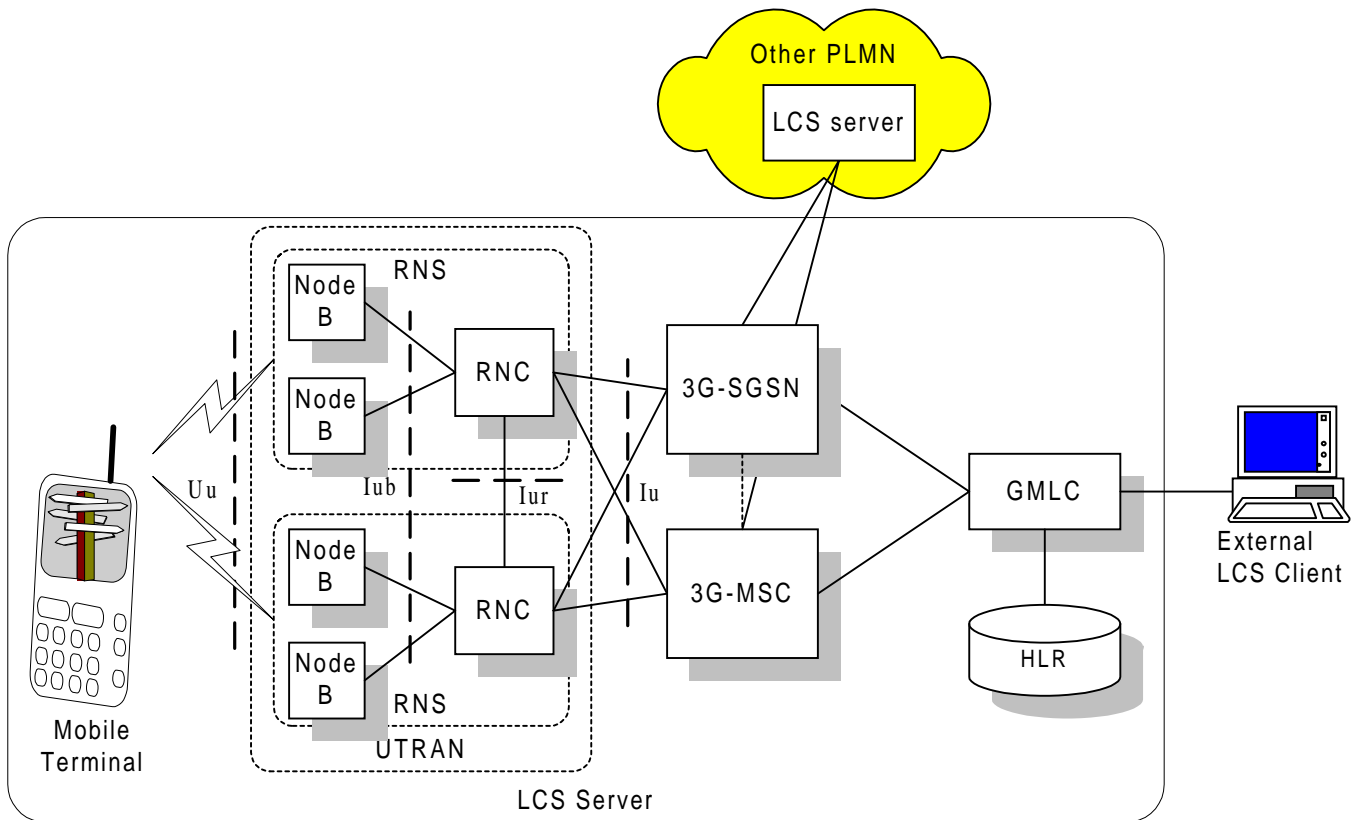

Figure 6.1, General arrangement of LCS in UMTS, UTRAN example

6.1 Schematic functional description of LCS operations in UMTS

The allocation of LCS functional blocks to the Client, LCS server, Core Network, Access Network and UE is based on the schematic functional description below. The detailed functions and interactions are specified later in this document and in TS 25.305 and corresponding Stage 3 specifications.

The operation begins with a LCS Client requesting location information for a UE from the LCS server. The LCS server will pass the request to the LCS functional entities in the UMTS core network. The LCS functional entities in the core network shall then:

- verify that the LCS Client is authorized to request the location of the UE or subscriber
- verify that LCS is supported by the UE
- establish whether it is allowed to locate the UE or subscriber, for privacy or other reasons
- establish which Serving RNC should receive the Location request if necessary by establishing a connection with the UE.
- request the Access Network (via the Iu interface) to provide location information for an identified UE, with indicated QoS
- receive information about the location of the UE from the Access Network and forward it to the Client
- send appropriate accounting information to an accounting function.

The Access Network LCS functional entities shall typically:

- request measurements, typically from the UE and radio network apparatus,
- send the measurement results to the appropriate calculating function within the Access Network,
- receive the result from the calculating function within Access Network,
- perform any needed co-ordinate transformations,
- send the results to the LCS entities in the core network.

In the event that the client is internal to the Access Network the request may be made directly to the Access Network LCS entities as the internal clients are considered to be “pre-authorised”.

As part of its operation, the calculating function may require additional information. This may be obtained by the function directly by communication with a database, or it may be through a request to LCS entities that will mediate the request and return of information from the appropriate database (or databases if more than one is needed to fulfill the requests). The LCS application may make use of the position information itself, or further process and then forward the information to other authorised applications within or external to the Access Network.

There may possibly also be available independent information that is able to supply the location information directly, or may be able to supply auxiliary information to the calculation function. The LCS co-ordination function, as part of its activity to supervise the positioning process, may query the UE or other elements of the network to determine their capabilities and use this information to select the mode of operation.

6.2 Allocation of LCS functions to UMTS network elements

Table 6.1 shows a summary of the Functional Groups and Functional Blocks for Location services in UMTS. Table 6.2 and Figure 6.2 show the generic configuration for LCS in UMTS and the distribution of LCS functional blocks to UMTS network elements. Different positioning methods, including network-based, mobile-based, mobile-assisted and network-assisted positioning methods may be used. With this configuration both the network and the mobiles are able to measure the timing of signals and compute the mobile's location estimate. Depending on the applied positioning method it is possible to utilise the corresponding configuration containing all needed entities. For instance, if network-based positioning is applied, the entities that are involved in measuring the mobile's signal and calculating its location estimate are allocated to the network elements of the access stratum. On the other hand, in case mobile-based or network-assisted methods are used these entities should be allocated to the mobile station.

LCS is logically implemented on the UMTS structure through the addition of one network node, the Mobile Location Center (MLC). It is necessary to name a number of new interfaces. The LCS generic architecture can be combined to produce LCS architecture variants.

Funct. Group	Functional component	Full name of Functional Block	Abbrev.
Loc. Client	Location Client component	(External) Location Client Function	LCF
		Internal Location Client Function	U-LCF -internal
LCS Server in PLMN	Client handling component	Location Client Control Function	LCCF
		Location Client Authorization Function	LCAF
	System handling component	Stand-alone LMU Mobility Management Function	LMMF
		Location System Control Function	LSCF
		Location System Control Function in RNC	U-LSCF
		Location System Billing Function	LSBF
		Location System Operations Function	LSOF

	Subscr. handling component	Location Subscriber Authorization Function	LSAF
		Location Subscriber Privacy function	LSPF
	Positioning component	UMTS- Positioning Radio Control Function	U-PRCF
		UMTS- Positioning Calculation Function	U-PCF
		UMTS- Positioning Signal Measurement Function	U-PSMF
		UMTS- Positioning Radio Resource Management	U-PRRM

Table 6.1, Summary of Functional Groups and Functional Blocks for Location services in UMTS

Figure 6.2 illustrates the allocation of functional entities in the reference configuration of LCS in UMTS. It is assumed that the CS and PS have either their own independent mobility management or use the joint mobility management through the optional Gs interface.

It is also seen that LCS in UMTS shall take benefit of the standardized Iur interface between RNSs, when uplink radio information and measurement results are collected.

The functional model presented in the figure includes functional entities for both CS and PS related LCS. In addition, it consists of all the entities needed for different positioning methods, i.e. network based, mobile based, mobile assisted, and network assisted positioning, exploiting either uplink or downlink measurements. It is noted that the mobile station may use e.g. the GPS positioning mechanism, but still demand e.g. auxiliary measurements from the serving network

	UE	RAN	GMLC	3G-SGSN	3G-MSC	Client
Location client functions						
LCF	X			X	X	X
U-LCF Internal	ffs	X				
Client handling functions						
LCCTF			X			
LCCF			X			
LCAF			X			
System handling functions						
LMMF				?	?	
LSCF				X	X	
U-LSCF		X				
LSBF			X	X	X	
LSOF	X	X	X	X	X	
Subscriber handling functions						
LSAF				X	X	
LSPF				X	X	
Positioning functions						
PRCF		X				
PCF	X	X				
PSMF	X	X				
PRRM		X				
	UE	RAN	GMLC	3G-SGSN	3G-MSC	Client

Table 6.2, Allocation of LCS functional entities to network elements

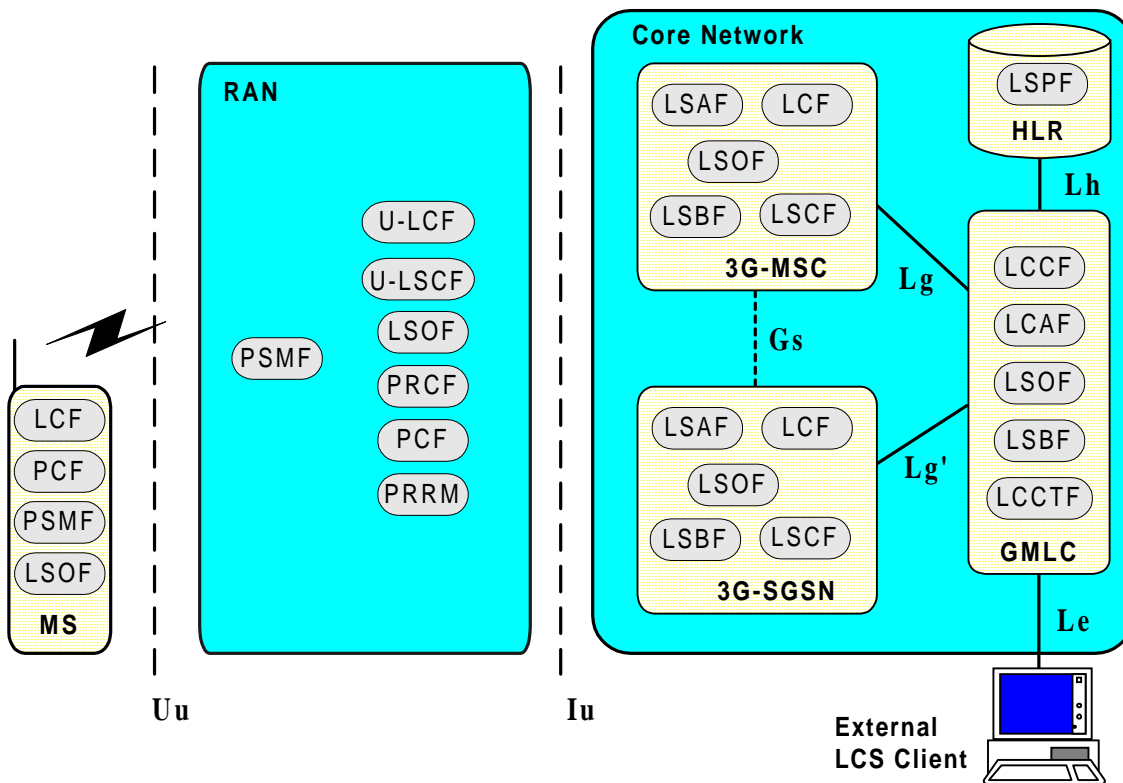

Figure 6.2, Generic LCS Logical Architecture

6.3 Functional description of LCS per network element

6.3.1 Access Network

The Access Network is involved in the handling of various positioning procedures.

Specific UTRAN functionality is specified in each of the positioning procedures sections in the UTRAN Stage 2, TS25.305.

6.3.2 LCS Clients and LCS applications

There are two classes of LCS Application – Internal applications and External applications. Internal applications represent entities internal to the UMTS that make use of location information for the (improved) operation of the network. External applications represent entities (such as Commercial or Emergency services) that make use of location information for operations external to the mobile communications network. The LCS Applications interface to the LCS entities through their Location Client functions (LCF).

The LCS Client and LCS applications are outside the scope of this standard.

6.3.3 Gateway Mobile Location Center, GMLC

The Gateway Mobile Location Center (GMLC) contains functionality required to support LCS. In one PLMN, there may be more than one GMLC.

The GMLC is the first node an external LCS client accesses in a GSM PLMN (i.e. the Le reference point is supported by the GMLC). The GMLC may request routing information from the HLR via the Lh interface or from 3G-SGSN via the Lg' interface. After performing registration authorization, it sends positioning requests to and receives final location estimates from the 3G-VMSC via the Lg interface or from the 3G-SGSN via the Lg' interface.

6.3.4 Serving RNC, UTRAN case

The Serving RNC (SRNC) is a network element of UTRAN and contains functionality required to support LCS in PLMN. The LCS functionality of SRNC is given in [1].

6.3.5 LCS support in the Mobile Station

The UE may be involved in the various positioning procedures. Specific UE involvement is specified in each of the positioning procedures specified in TR 25.305.

The UE interacts with the measurement coordination functions to transmit the needed signals for uplink based LCS measurements and to make measurements of downlink signals. The measurements to be made will be determined by the chosen location method.

The UE may also contain LCS applications, or access an LCS application through communication with a network accessed by the UE or an application residing in the UE. This application may include the needed measurement and calculation functions to determine the UE's location with or without assistance of the UMTS LCS entities.

The UE may also, for example, contain an independent location function (e.g. Global Satellite Positioning Service GPS) and thus be able to report its location, independent of the UTRAN transmissions. The UE with an independent location function may also make use of information broadcast by the UTRAN that assists the function.

6.3.6 LMU

The Location Measurement Unit LMU entity makes measurements (e.g. of radio signals) and communicates these measurements to the PRCF in the Access Network. The LMU contains a PSMF and may also perform calculations associated with the measurements. The LMU is described in [1]

Management aspects of the LMU by the Core Network are FFS.

6.3.7 3G-MSC/VLR

The 3G-MSC/VLR contains functionality responsible for UE subscription authorization and managing call-related and non-call related positioning requests of LCS. The 3G-MSC is accessible to the GMLC via the Lg interface. The LCS functions of 3G-MSC are related to charging and billing, LCS co-ordination, location request, authorization and operation of the LCS services.

6.3.8 3G-SGSN

The 3G service GPRS support node 3G-SGSN contains functionality responsible for UE subscription authorization and managing call-related and non-call related positioning requests of LCS. The 3G-SGSN is accessible to the GMLC via the Lg' interface. The LCS functions of 3G-SGSN are related to charging and billing, LCS co-ordination, location request, authorization and operation of the LCS services.

6.3.9 Home Location Register, HLR

The HLR contains LCS subscription data and routing information. The HLR is accessible from the GMLC via the Lh interface. For roaming UEs, HLR may be in a different PLMN than the current SRNC.

6.3.10 gsmSCF

The Lc interface supports CAMEL access to LCS and is applicable only in CAMEL [phase 3?]. The procedures and signaling associated with it are defined in TS 23.078 and TS 29.002, respectively.

6.4 Addressing the target UE for LCS purposes

It shall be possible to address and indicate the target UE using MSISDN and IP addresses. This is FFS.

7 Signaling Protocols and Interfaces

7.1 Signalling protocols for LCS support in UMTS

[Text to be added.]

7.2 Iu interface

The Iu interface is used to communicate between the LCS functional entities in the Core Network and the LCS entities in the Access Network.

This interface passes the location requests and responses from authenticated external and internal LCS applications between the LCS entities in the Core Network and the Access Network LCS entities. The information elements in the location reporting control and in the location report messages over the Iu interface are listed below.

[Editor's note: The above deleted sentence is unclear; this kind of information exchange is not currently supported by Iu or GSM LCS specifications.]

[Editor's note: O&M issues are outside the scope of this specification; this kind of information exchange is not currently supported by Iu or GSM LCS specifications.]

7.2.1 Information Flows between UTRAN and the Core Network

The information flows pass over the Iu interface between the UTRAN and the CN. Support for LCS signaling over the Iu interface is specified in TS 25.413 RANAP signalling [14].

Location Reporting Control

Via the Location Reporting Control message the , the Core Network LCS entities communicates with the LCS entities in Access Network to request the location information of one or more than one UE within a specified quality of service. The location reporting control message is issued from the CN to RNC. There exist two types of location information requests:

- Location Immediate Request (LIR); and
- Location Deferred Request (LDR).

In case of UEs in Idle Mode, the selection of the RNC by the CN when the Location/ Routing area spans multiple RNCs is FFS.

The following attributes are identified for the Location Information Request :

[Editor's note: This list is subject to further review and the attributes should be further defined.]

- Target UE or MS(s);
- [Indication what could be the achievable accuracy for the Target UE, generated based on UE capabilities and radio conditions, this attribute probably can be replaced by "Requested QoS", this is ffs]
- LCS identity [This parameter probably is the same as the "reporting number" mentioned in 25.413];
- State (idle, dedicated) [the purpose of this attribute is not evident, state of what?]
- Event (applicable to LDR requests only), the possible events that trigger a deferred location response are to be defined;
- Requested Quality of Service of the LCS information;
- Local coordinate reference system;
- Geographical area, [should be checked with the meaning of "Geographical area" in 03.71.]

7.2.2 Location Report

The Location Service Response is sent to the LCS client as the result of the Location Service Request by the LCS Server:

- Immediate Response; and
- Deferred Response;

These deferred responses can be either single or periodic.

The following attributes are identified for the Location Report information flow:

[Editor's note: This list is subject to further review and the attributes should be further defined.]

- Location indication of UE in geographical coordinates
- Location of UE as an ellipsoid with axes and direction of all axis
- Estimated achieved QoS;
- Indication when UE enters or leaves the Geographical area.

Some information attributes may be common for the location service request and location report, such as Target UE, LCS identity, State, Event, Local co-ordinate system, geographical area.

7.3 Iur Interface, Signaling between RNCs

The Iur interface is used to communicate between the LCS functional entities associated with the serving RNC and other RNC in the UTRAN. The Iur interface support for LCS is specified in UTRAN Stage 2.

7.4 Uu Interface

The Uu interface is used to communicate among the LCS entities associated with the RNC, the UEs and the stand-alone Location Measurement Units (LMU). The Uu interface is also used to communicate between the LCS entities in the core network and the UE.

This interface may pass measurement requests and results to and from UE or the stand-alone LMU.

The Uu interface may also pass location requests from internal or external LCS Clients (Applications) at the UE. Note that these requests may require the services of the LCS entities associated with the core network to authenticate clients and subscriber subscriptions to aspects of the LCS.

The Uu interface may also be used for broadcast of information that may be used by the UE or stand-alone LMU for their LCS operations. This may, for example, include timing and code information about nearby Node-B transmissions that may assist the UE or LMU in making their measurements.

The Uu interface may also pass messages relating to changes or reporting of the data associated with the Location System Operations Function (LSOF) in the UE or the remote LMU.

UTRAN Stage 2 specification 25.305 [1] specifies LCS signaling over the Uu interface.

7.4.1 MAP Interfaces

The MAP interfaces defined for GSM LCS should be re-used as much as possible in UMTS. It is seen feasible to use the same MAP interface between GMLC and 3G-SGSN, as between GMLC and 3G-MSC.

There are two MAP interfaces in the UMTS Location Services:

- Interface between GMLC and HLR (Lh interface)

This interface is used by the GMLC to request the address of the visited MSC or 3G-SGSN for a particular target UE whose location has been requested.

- Interface between GMLC - MSC and GMLC – 3G-SGSN (Lg interface)

This interface is used by the GMLC to convey a location request to the MSC or 3G-SGSN currently serving a particular target UE whose location was requested. The interface is used by the MSC or 3G-SGSN to return location results to the GMLC.

The following MAP services are defined for GSM LCS and should be re-used for UMTS LCS:

- MAP-SEND-ROUTING-INFO-FOR-LCS Service

This service is used between the GMLC and the HLR to retrieve the routing information needed for routing a location service request to the servicing 3G-VMSC or 3G-SGSN.

- MAP-PROVIDE-SUBSCRIBER-LOCATION Service

This service is used by a GMLC to request the location of a target UE from the visited MSC or 3G-SGSN at any time.

- MAP-SUBSCRIBER-LOCATION-REPORT Service

This service is used by a 3G-VMSC or 3G-SGSN to provide the location of a target UE to a GMLC when a request for location is either implicitly administered or made at some earlier time.

8 General network location procedures

8.1 State description for GMLC

8.1.1.1 NULL State

In the NULL state, a particular location request from some LCS client either has not been received yet or has already been completed. After a location request is received from a LCS client, the GMLC remains in the NULL state while the identity of the client and nature of its location request are verified. While the NULL state exists conceptually, it need not be represented explicitly in the GMLC.

8.1.1.2 INTERROGATION State

In this state, the GMLC has sent an interrogation to the home HLR of the UE to be located and is awaiting a response giving the 3G-VMSC and/or 3G-SGSN address and IMSI for this UE.

8.1.1.3 LOCATION State

In this state, the GMLC has sent a location request to the 3G-VMSC/3G-SGSN serving the UE to be located and is awaiting a response containing a location estimate.

8.1.2 State Functionality

8.1.2.1 State Transitions

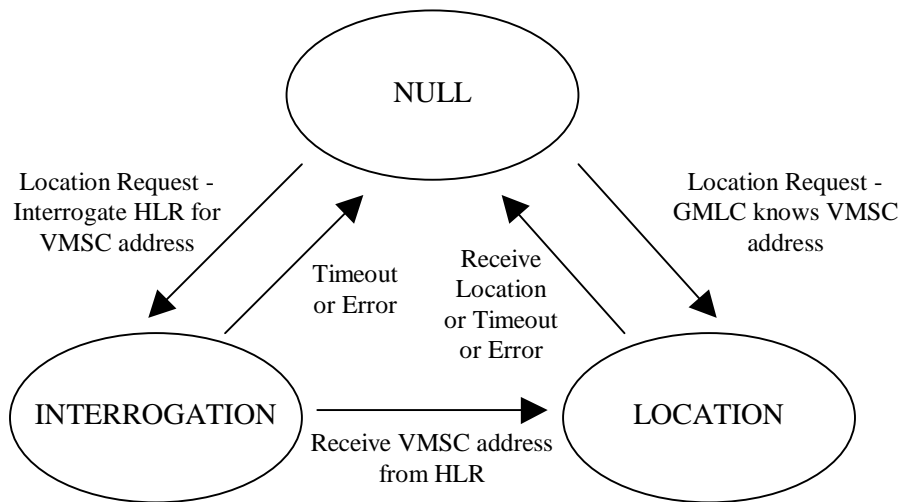

Figure 8.1, State Transitions in the GMLC

Moving from NULL to INTERROGATION state:

If the GMLC does not know the 3G-VMSC/3G-SGSN address or IMSI when it receives a location service request from some LCS client, it moves from the NULL state to the INTERROGATION state and sends a request to the UE's home HLR for the 3G-VMSC/3G-SGSN address and IMSI.

Moving from NULL to LOCATION state:

If the GMLC already knows both the 3G-VMSC/3G-SGSN address and UE IMSI when it receives a location service request from some LCS client (e.g. from information retained for an earlier location request for the same UE), it moves from the NULL state to the LOCATION state and sends a location request to the 3G-VMSC/3G-SGSN.

Moving from INTERROGATION to LOCATION state:

After the GMLC, in the INTERROGATION state, receives the 3G-VMSC/3G-SGSN address and IMSI from the home HLR, it enters the LOCATION state and sends a location request to the 3G-VMSC of the UE being located.

Moving from LOCATION to NULL state:

After the GMLC receives a location estimate response from the 3G-VMSC/3G-SGSN, it forwards the location estimate to the requesting LCS client and reenters the NULL state.

8.1.2.2 INTERROGATION Timer Function

The GMLC runs a timer while in the INTERROGATION state to limit the amount of time waiting for an interrogation response from the HLR. If the timer expires before an interrogation response is received, the GMLC indicates a location failure to the LCS client and reenters the NULL state.

8.1.2.3 LOCATION Timer Function

The GMLC runs a timer while in the LOCATION state to limit the amount of time waiting for a location estimate response from the 3G-VMSC/3G-SGSN. If the timer expires before a response is received, the GMLC indicates a

location failure to the LCS client and reenters the NULL state.

8.2 State description for 3G-VMSC/VLR

8.2.1 3G-VMSC States

8.2.1.1 LCS IDLE State

In this state, the 3G-VMSC location service is inactive for a particular UE. The UE may be known in the VLR (except for a USIM less or SIM less Emergency call or where the UE record has been canceled or lost in the VLR), but there may not be an active Mobility Management or Radio Resource connection to the UE.

8.2.1.2 LOCATION State

In this state, the 3G-VMSC is awaiting a response from SRNC after requesting the location for a particular UE. In this state, a RRC and a Mobility Management connection and the LCS layer of the Connection Management connection to the target UE will be active – allowing the SRNC and UE to exchange positioning related messages for mobile based and mobile assisted position methods.

8.2.2 State Functionality

8.2.2.1 State Transitions

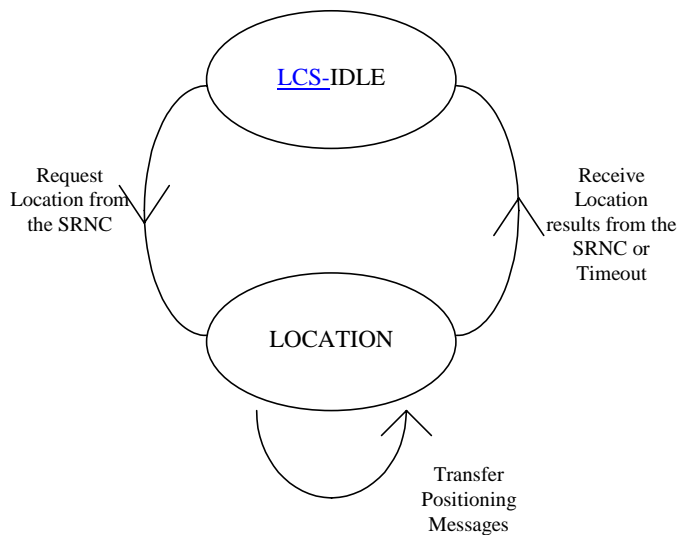

Figure 8.2, State Transitions in the 3G-VMSC

Moving from LCS IDLE to LOCATION state:

After a request has been received to locate a particular UE and the UE subscription options have been verified, a location request is sent to the SRNC associated with the serving cell of the UE to be located: the 3G-VMSC then enters the LOCATION state. Before entering this state, the 3G-VMSC must have setup a Mobility Management connection to the UE if none was previously active. The mobile is paged and authenticated before positioning.

Moving from LOCATION to LCS IDLE state:

After the return of a location estimate result from SRNC, the 3G-VMSC shall re-enter IDLE state.

8.2.2.2 LOCATION Timer Function

The 3G-VMSC runs a timer while in the LOCATION state to limit the amount of time waiting for a location response from the RNC. If the timer expires before such information is received, the 3G-VMSC indicates a location failure to the original requesting entity and reenters IDLE state.

8.3 LCS State description for 3G-SGSN**8.3.1 3G-SGSN States****8.3.1.1 LCS IDLE State**

In this state, the 3G-SGSN location service is inactive for a particular UE.

8.3.1.2 LOCATION State

In this state, the 3G-SGSN is awaiting a response from the SRNC after requesting the location for a particular UE.

8.3.2 State Functionality**8.3.2.1 State Transitions**

Figure 8.3, State Transitions in the 3G-SGSN

Moving from LCS-IDLE to LOCATION state:

After a request has been received to locate a particular UE and the UE subscription options have been verified to allow this, the 3G-SGSN sends a location request to the SRNC associated with the UE to be located. The 3G-SGSN then

enters the LOCATION state.

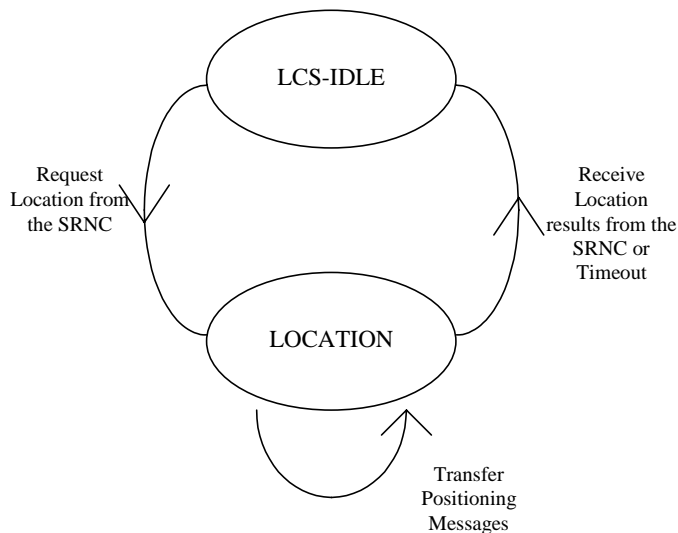
Moving from LOCATION to LCS IDLE state:

After the return of a location estimate result from SRNC, or if the Location Timer described below expires, the 3G-SGSN shall re-enter IDLE state.

8.3.2.2 LOCATION Timer Function

The 3G-SGSN runs a timer while in the LOCATION state to limit the amount of time waiting for a location response from the SRNC. If the timer expires before such information is received, the 3G-SGSN indicates a location failure to the original requesting entity and reenters IDLE state.

8.4 State description for RNC in UTRAN

The state description of RNC in UTRAN is specified in TS 25.305.

8.5 General Network Positioning Procedures

The generic network positioning procedure of providing the location information of an UE subscriber can be partitioned into the following procedures:

Location Preparation Procedure

This generic procedure is concerned with verifying the privacy restrictions of the UE subscriber, reserving network resources, communicating with the UE to be located and determining the positioning method to be used for locating the UE subscriber based on the requested QoS and the UE and network capabilities.

Positioning Measurement Establishment Procedure

This procedure is concerned with performing measurements by involving the necessary network and/or UE resources. Depending on the positioning method to be used for locating the UE the internals of this procedure can be positioning method dependent. The procedure is completed with the end of the positioning measurements.

Location Calculation and Release Procedure

This generic procedure is initiated after the measurements are completed and is concerned with calculating the location of the UE and releasing all network and/or UE resources involved in the positioning.

8.6 Mobile Terminating Location Request

8.6.1 Circuit Switched Mobile Terminating Location Request (CS-MT-LR)

Figure 8.4 illustrates general network positioning for LCS clients external to the PLMN. In this scenario, it is assumed that the target UE is identified using either an MSISDN or IMSI.

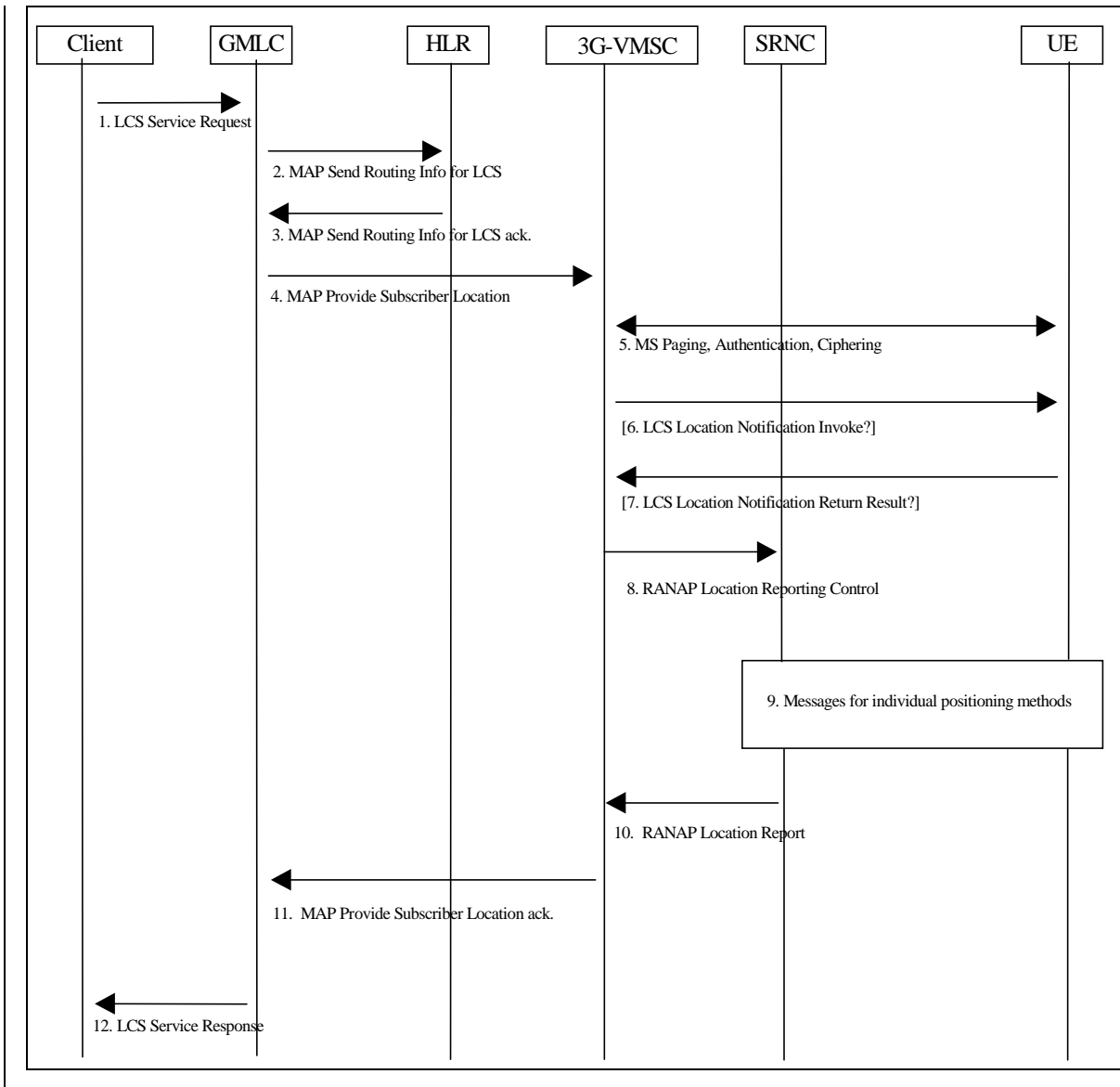

Figure8.4, General Network Positioning for a MT-LR

8.6.1.1 Location Preparation Procedure

1. An external LCS client requests the current location and possibly the velocity of a target UE from a GMLC. The GMLC verifies the identity of the LCS client and its subscription to the LCS service requested and derives the MSISDN or IMSI of the target UE to be located and the LCS QoS from either subscription data or data supplied by the LCS client. For a call related location request, the GMLC obtains and authenticates the called party number of the LCS client [(refer to Annex A for further details)]. If location is required for more than one UE, or if periodic location is requested, steps 2 to 12 below may be repeated.
2. If the GMLC already knows both the 3G-VMSC location and IMSI for the particular MSISDN (e.g. from a previous location request), this step and step 3 may be skipped. Otherwise, the GMLC sends a MAP_SEND_ROUTING_INFO_FOR_LCS message to the home HLR of the target UE to be located with either the IMSI or MSISDN of this UE.
3. The HLR verifies that the calling party SCCP address of the GMLC, corresponds to a known UMTS network element that is authorized to request UE location information. The HLR then returns the current 3G-VMSC address and whichever of the IMSI and MSISDN was not provided in step (2) for the particular UE.
4. The GMLC sends a MAP_PROVIDE_SUBSCRIBER_LOCATION message to the 3G-MSC indicated by the HLR. This message carries the type of location information requested (e.g. current location and possibly velocity), the UE subscriber's IMSI, LCS QoS information (e.g. accuracy, response time) and an indication of whether the

LCS client has the override capability. For a call related location request, the message also carries the LCS client's called party number. The message may optionally carry the identity of the LCS client.

5. If the GMLC is located in another PLMN or another country, the 3G-VMSC first authenticates that a location request is allowed from this PLMN or from this country. If not, an error response is returned. The 3G-VMSC then verifies LCS barring restrictions in the UE user's subscription profile in the VLR. In verifying the barring restrictions, barring of the whole location request is assumed if any part of it is barred or any requisite condition is not satisfied. If LCS is to be barred without notifying the target UE, and a LCS client accessing a GMLC in the same country does not have the override capability, an error response is returned to the GMLC. Otherwise, if the UE is in idle mode, the Core Network performs paging, authentication and ciphering.

[GSM LCS: If the target UE has an established circuit call other than speech, the location request may be denied and an error response is then returned to the GMLC. If the location request is allowed for a non-speech circuit call, it shall be up to the SRNC to decide, on the basis of the applicable position methods and requested QoS, whether positioning is possible. *[this is FFS]*]

6. [If the location request comes from a value added LCS client and the UE subscription profile indicates that the UE must be notified and the UE supports notification of LCS, an LCS Privacy Verification Invoke message is sent to the target UE indicating the type of location request (e.g. current location possibly with velocity) and the identity of the LCS client.] *[This functionality needs to be further studied.]*
7. [The target UE notifies the UE user of the location request and waits for the user to grant or withhold permission. The UE then returns an LCS Privacy Verification Return Result to the 3G-VMSC indicating whether permission is granted or denied. If the UE user does not respond after a predetermined time period, the UE shall return an LCS Privacy Verification Return Error message indicating a timeout. The 3G-VMSC shall return an error response to the GMLC if the UE user denies permission or if there is a timeout in the target UE and the UE subscription profile indicates barring of the location request.] *[This functionality needs to be further studied.]*
8. The 3G-MSC sends a RANAP Reporting Control message to the SRNC. This message includes the type of location information requested, the UE's location capabilities and requested QoS.
[GSM location request contains in addition the current Cell ID and, if available, any location information including the TA value received earlier. The use of Cell Id in UMTS is FFS.]

8.6.1.2 Positioning Measurement Establishment Procedure

9. If the requested location information and the location accuracy within the QoS can be satisfied based on cell coverage [cell ID] and, if available, RTT value, the SRNC may send a RANAP Location Report immediately. Otherwise, the SRNC determines the positioning method and instigates the particular message sequence for this method in UTRAN Stage 2 [1]. If the position method returns position measurements, the SRNC uses them to compute a location estimate and, possibly, a velocity estimate. If there has been a failure to obtain position measurements, the SRNC may use the current cell information and, if available, RTT value to derive an approximate location estimate. If an already computed location estimate is returned for an UE based position method, the SRNC may verify consistency with the current cell and, if available, RTT value. If the location estimate so obtained does not satisfy the requested accuracy and sufficient response time still remains, the SRNC may instigate a further location attempt using the same or a different position method. If velocity and location are requested but the SRNC can only obtain location, this may be returned without the velocity. If a vertical location coordinate is requested but the SRNC can only obtain horizontal coordinates, these may be returned.

In case IPDL is used the SRNC may send a message to the BS/Node B to configure the power cease period of the Node Bs involved in the positioning process. However, if the IPDL alignment is specified in lower layers e.g. layer 1 then the functional split of IPDL processing may partly included in network elements functionality.

8.6.1.3 Location Calculation and Release Procedure

10. When a location estimate best satisfying the requested QoS has been obtained, the SRNC returns it to the 3G-MSC in a Location Report message. If a location estimate could not be obtained, the SRNC returns a Location Report message containing a failure cause and no location estimate.

11. The 3G-MSC returns the location information and its age to the GMLC. If the SRNC did not return a successful location estimate, but the privacy checks in steps 6-7 were successfully executed, the 3G-VMSC may return the last known location of the target UE if this is known and the LCS client is requesting the current or last known location. The VLR may then release the Mobility Management connection to the UE, if the UE was previously idle, and the 3G-MSC may record billing information.
12. The GMLC returns the UE location estimate to the requesting LCS client. If the LCS client requires it, the GMLC may first transform the universal location coordinates provided by the 3G-MSC into some local geographic system. The GMLC may record billing for both the LCS client and inter-network revenue charges from the 3G-MSC's network.

8.6.2 MT-LR for a previously obtained location estimate

Every time the location estimate of a target UE subscriber is returned by the SRNC to the 3G-VMSC, the 3G-VMSC may store the location estimate together with a time stamp in the subscriber's VLR record.

The time stamp is the time at which the location estimate is stored at the VLR i.e. after the SRNC returns the location estimate to the 3G-VMSC. The time stamp indicates the 'age' of the location estimate.

8.6.2.1 Initial Location

In the context of an originating emergency call the location estimate and the associated time stamp at the commencement of the call set-up is referred to as '*initial location*'.

8.6.2.2 Current Location

After a location attempt has successfully delivered a location estimate and its associated time stamp, the location estimate and time stamp is referred to as the '*current location*' at that point in time.

8.6.2.3 Last known Location

The current location estimate and its associated time stamp are stored in MSC/VLR and until replaced by a later location estimate and a new time stamp is referred to as the '*last known location*'. The last known location may be distinct from the initial location – i.e. more recent.

[Editors note: the last known position should also be kept in HLR, since VLR will delete all subscriber information when the subscriber leaves the VLR service area.]

Figure 8.7 illustrates location where the 3G-VMSC does not invoke positioning but returns either a location estimate or a failure indication. This scenario is valid for the following types of location request:

- (a) Some time after an emergency services call has started, an emergency services client requests the initial location of the target UE at the start of the emergency call. (If the emergency call has just started, the 3G-VMSC may follow the procedure in Figure to obtain the initial location).
- (b) A LCS client requests the current or last known location with a "no delay" response time.

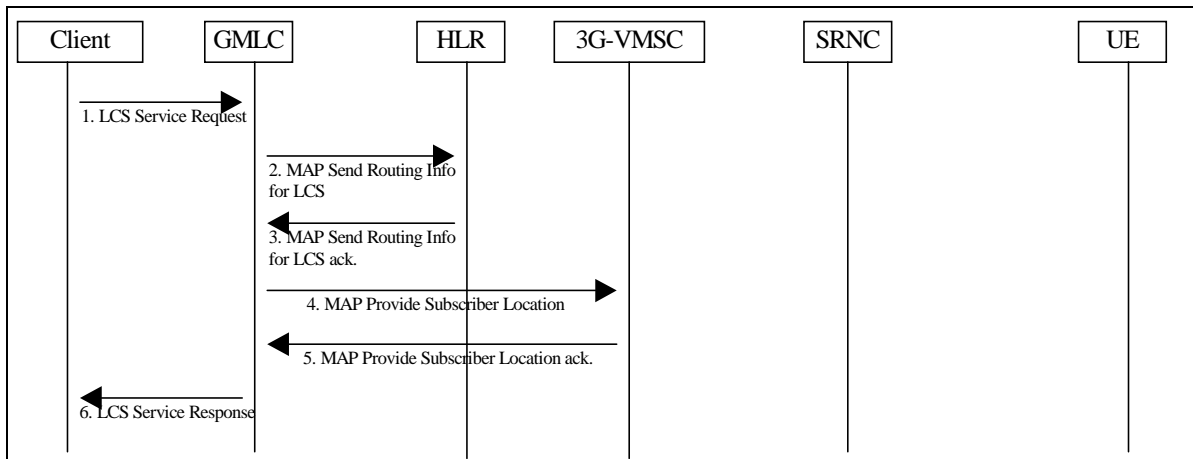

Figure 8.7 MT-LR for a previously obtained location estimate

- (1) Same as step 1 for a normal MT-LR, but with the LCS client requesting either the initial location for an emergency call or current or last known location with a “no delay” response time.
- (2) If an emergency services client is requesting the initial location and the GMLC already has this stored from a previous location delivery (e.g. using NI-LR), the initial location is returned immediately in step 6 with other steps omitted. Otherwise, the GMLC may query the HLR for the address of the 3G-VMSC as in step 2 for a normal MT-LR. If the 3G-VMSC is identified using a NA-ESRK, NA-ESRD or previously stored information for the target UE, then this step and step 3 are not needed.
- (3) Same as step 3 for an MT-LR.
- (4) Same as step 4 for an MT-LR. The message sent to the 3G-VMSC requests either an initial location or current or last known location with “no delay”.
- (5) If the initial location for an emergency call is requested and the 3G-VMSC has previously obtained and stored this, this location estimate and its age are returned to the GMLC. Otherwise, if the initial location is requested but is not stored and this is not the start of the emergency call, a failure indication is returned. If the current or last known location is requested with “no delay”, the last known location currently stored in the 3G-VMSC and its age are returned; if no last known location is stored, a failure indication is returned.
- (6) Same as step 12 for a normal MT-LR.

8.6.2.4 Security and Privacy

The handling of security and privacy of the target UE with regard to returning the last known or initial location estimate of the target UE shall be the same as when the target UE is reachable for positioning. (i.e. the requesting LCS client is authorized and the privacy of the target UE is secured before the 3G-VMSC check the VLR status of the target UE (i.e. whether the UE is marked as attached or detached in the VLR).

8.6.2.5 Failing to locate the target UE

In case of a ‘Detached’ or ‘Not Reachable’ target UE, the last known location and a time stamp stored at the VLR, may be returned to a LCS client requesting location information. This does not apply to a value added LCS client where the target UE subscribes to notification of the location request: if the notification cannot be performed, the 3G-VMSC shall reject the location request.

Note: Due to CAMEL, the MSC/VLR may already be storing other location information parameters like location number, [cell id], location area identity and VLR number in the subscriber’s VLR record.

When a request for location information is received at the 3G-VMSC, the request shall indicate whether the 'last known location of the target UE' should be returned in case of a 'detached' or 'not reachable' target UE.

If the VLR has a valid copy of the subscriber's permanent data and the target UE's privacy settings are such that positioning is allowed, then the following two cases can occur.

8.6.2.5.1 Target UE is 'Not Reachable'

If the target UE is marked as 'attached' in the VLR, the 3G-VMSC orders paging of the target UE. If paging fails, due to target UE being 'not reachable' then 3G-VMSC shall check whether the LCS client has requested 'last known location' in case of 'not reachable' target UE.

If such a request exists and notification to the target UE does not apply for a value added LCS client, the 3G-VMSC shall include the last known location together with the time stamp available in its response to the request for location information.

An indicator of 'last known location' returned shall be marked at the CDR at 3G-VMSC.

8.6.2.5.2 Target UE is 'Detached'

If the target UE is marked as 'detached' in the VLR, the 3G-VMSC shall check whether the LCS client has requested 'last known location' in case of 'detached' target UE.

If such a request exists and notification to the target UE does not apply for a value added LCS client, the 3G-VMSC includes the 'last known location' together with the time stamp available in its response to the request for location information.

An indicator of 'last known location' returned shall be marked at the CDR at 3G-VMSC.

8.6.2.5.3 Target UE is 'Purged'

If the target UE is marked as 'Purged' in HLR, then an indication 'Absent Subscriber' is returned to the GMLC.

8.6.3 Network Induced Location Request (NI-LR)

Figure 8.8 illustrates positioning for an emergency service call.

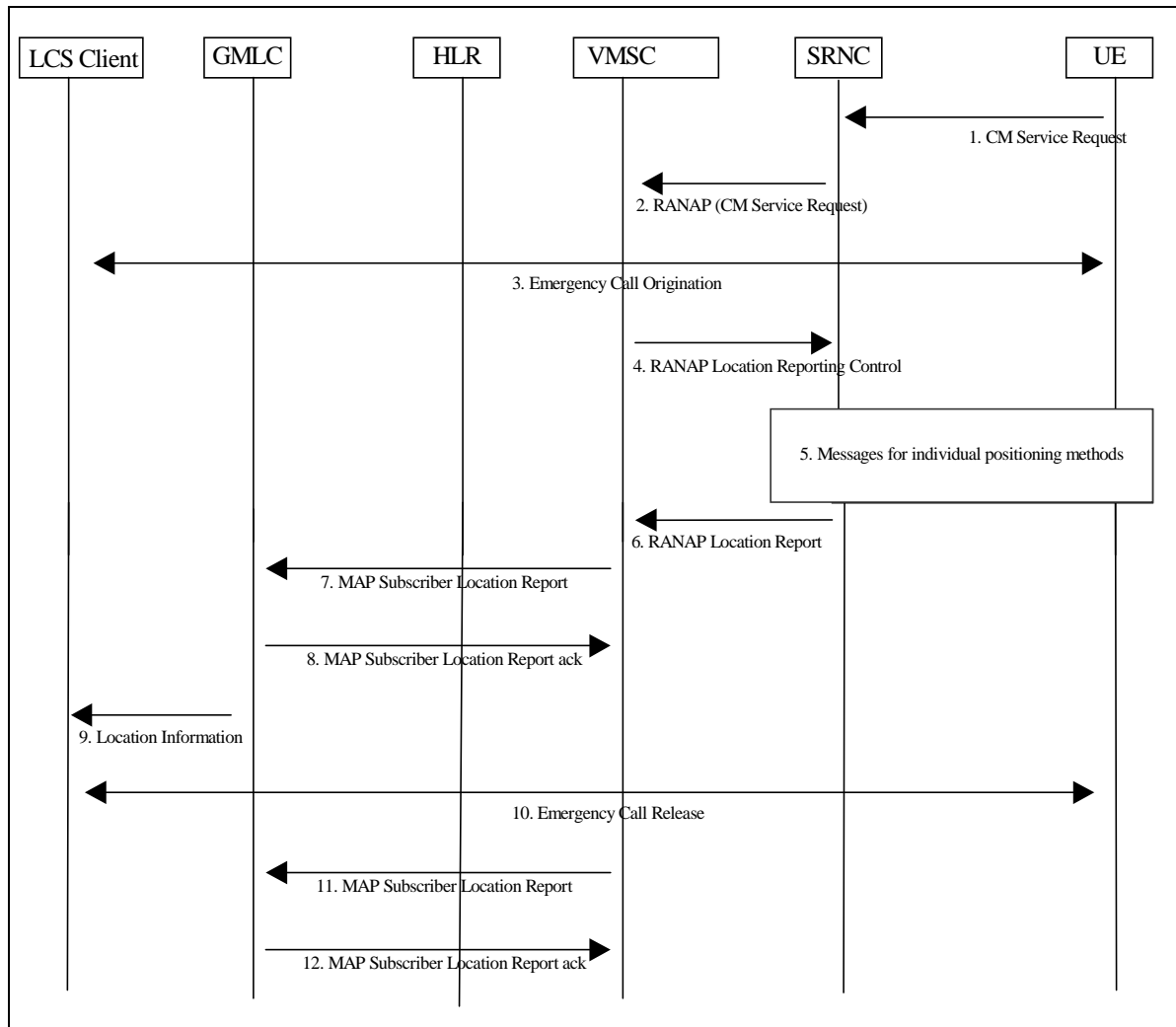

Figure 8.8 Positioning for a NI-LR Emergency Service Call

8.6.3.1 Location Preparation Procedure

- (1) An initially idle UE requests RRC setup (RACH) Service Request indicating a request for an Emergency Service call to the 3G-VMSC via the SRNC.
- (2) The SRNC shall include [the current cell ID and other] location information (e.g. the RTT value) within the RANAP message used to convey the CM (Before having a CM connection there must be a RRC connection) service request across the Iu-interface. The UE may identify itself using a TMSI, IMSI or IMEI.

[Editor's note: The use of Cell Id is for further study.]

- (3) The emergency call procedure is applied.
- (4) The 3G-VMSC, SRNC and UE continue the normal procedure for emergency call origination towards the appropriate emergency services client. Depending on local regulatory requirements, the sending of call setup information into the PSTN may be delayed until either the UE's location has been obtained or the location attempt has failed or a PLMN defined timer has expired before location was obtained. Call setup information sent into the PSTN may include the UE location (if already obtained) plus information that will enable the emergency service provider to request UE location at a later time (e.g. NA-ESRD and NA-ESRK in North America).
- (5) At any time after step 1, the 3G-VMSC may initiate procedures to obtain the UE's location. These procedures may run either in parallel with the emergency call origination or while emergency call origination is suspended to delay sending of call setup information into the PSTN according to step 3. The 3G-VMSC sends a RANAP Location Request message to the SRNC associated with the UE's current location area (see step 8 for an MT-LR). This message includes the UE's location capabilities and currently assigned radio channel type, the QoS required for an

emergency call and [the current Cell ID and] any location information including the TA value received in step 2.

8.6.3.2 Positioning Measurement Establishment Procedure

- (6) The actions described under step 9 for a MT-LR are performed. If a speech compatible traffic channel is established, the same traffic channel may be used for both the positioning and the emergency call. In that case, the traffic channel may be allocated by either the positioning procedure or emergency call origination procedure.

8.6.3.3 Location Calculation and Release Procedure

- (7) When a location estimate best satisfying the requested QoS has been obtained, the SRNC returns it to the 3G-VMSC.
- (8) Depending on local regulatory requirements, the 3G-VMSC may send a MAP Subscriber Location report to a GMLC associated with the emergency services provider to which the emergency call has been or will be sent. This message shall carry any location estimate returned in step 6, the age of this estimate and may carry the MSISDN, IMSI and IMEI of the calling UE. In North America, any NA-ESRD and any NA-ESRK that may have been assigned by the 3G-VMSC shall be included. The message shall also indicate the event that triggered the location report. If location failed (i.e. an error result was returned by the SRNC in step 7), an indication of failure rather than a location estimate may be sent to the GMLC: the indication of failure is conveyed by not including a location estimate in the MAP Subscriber Location Report.
- (9) The GMLC acknowledges receipt of the location information. The GMLC may store the location information for later retrieval by the emergency services LCS client. If so, the acknowledgment to the 3G-MSC shall request notification when the emergency call has ended.
- (10) The GMLC may optionally forward the information received in step 8 to the emergency services LCS client. For a North American emergency services call this client may be selected according to the NA-ESRD provided in step 8.
- (11) At some later time, the emergency services call is released.
- (12) If the GMLC requested notification of emergency call release in step 9, the 3G-MSC sends another MAP Subscriber Location Report to the GMLC. This message may include the same parameters as before except that there is no position estimate and an indication of emergency call termination is included.
- (13) The GMLC acknowledges the 3G-MSC notification and may then release all information previously stored for the emergency call.

8.6.4 Network Induced Location Request (NI-LR) from a Serving RNC for a target UE in dedicated mode

Figure 8.9 illustrates how a serving RNC may obtain the location of a target UE that is already in dedicated mode on behalf of some PLMN operator LCS client – e.g. to support handover. The procedure is valid for SRNC when local regulatory requirements do not require privacy checking for PLMN operator initiated location.

[Editor's note: "dedicated mode" means that the UE has been authenticated.]

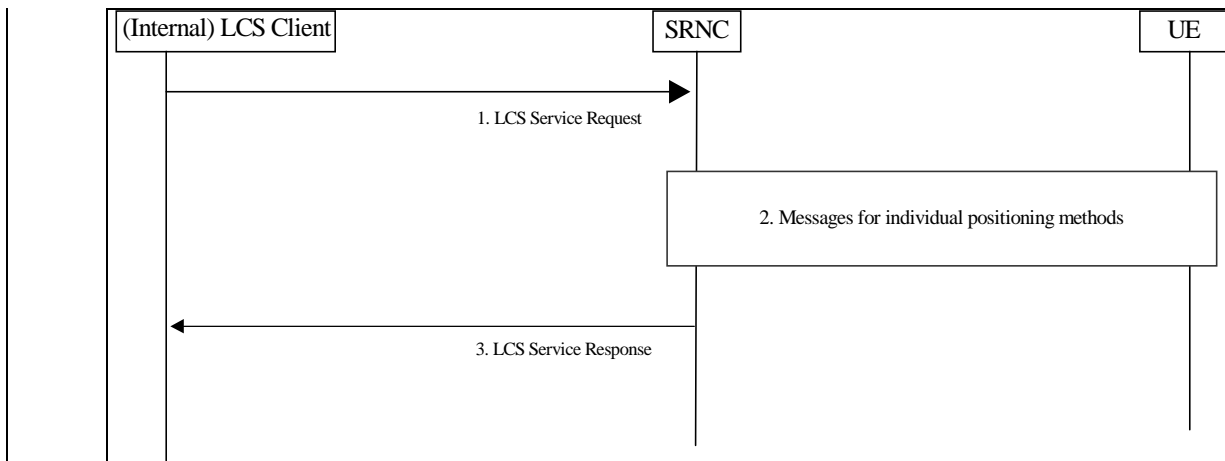

Figure 8.9 Network Induced Location Request from a Serving RNC

8.6.4.1 Location Preparation Procedure

(1) An LCS client within the SRNC requests the current location of a target UE from the SRNC.

8.6.4.2 Positioning Measurement Establishment Procedure

(2) Refer to step 9 for an MT-LR.

8.6.4.3 Location Calculation and Release Procedure

(3) The SRNC returns the UE location estimate to the requesting LCS client.

8.7 Mobile Originating Location Request

8.7.1 Mobile Originating Location Request, Circuit Switched (CS-MO-LR)

The following procedure shown in figure 8.10 allows an UE to request either its own location, location assistance data or broadcast assistance data message ciphering keys from the network. Location assistance data may be used subsequently by the UE to compute its own location throughout an extended interval using a mobile based position method. A ciphering key enables the UE to decipher other location assistance data broadcast periodically by the network. The MO-LR after location update request may be used to request ciphering keys or GPS assistance data using the follow-on procedure described in TS 24.008. The procedure may also be used to enable an UE to request that its own location be sent to another LCS client.

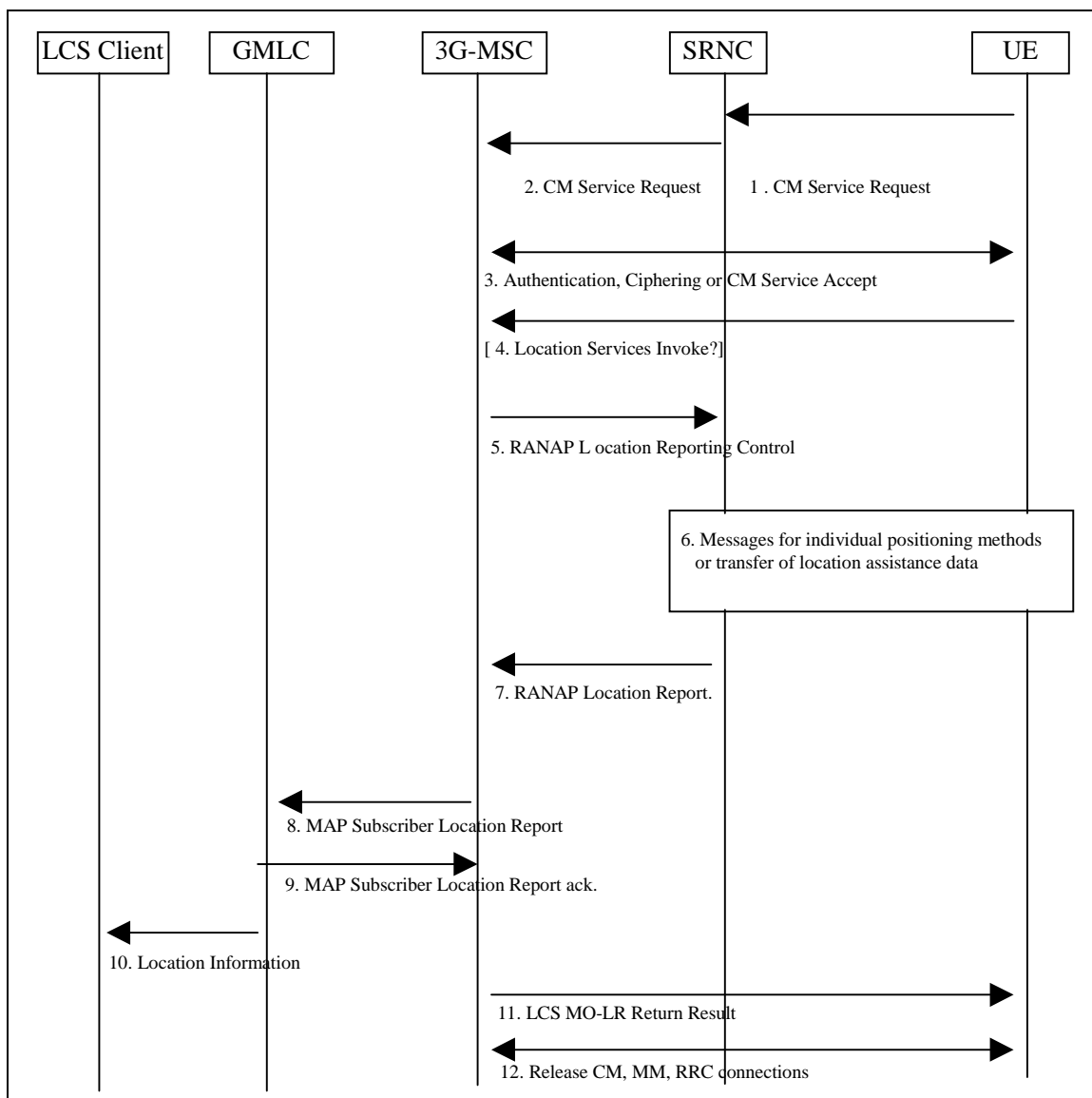

Figure 8.10 General Network Positioning for MO-LR

8.7.1.1 Location Preparation Procedure

1. If the UE is in idle mode, the UE requests a RACH and sends a CM service request indicating a request for a call independent supplementary services to the 3G-VMSC via the SRNC.
2. The SRNC shall include the [current cell ID and] RTT value within the RANAP Direct Transfer message used to convey the CM service request across the Iu-interface. If the UE is in dedicated mode, the UE sends a CM Service Request on the already established RACH.
3. The 3G-VMSC instigates authentication and ciphering if the UE was in idle mode or returns a Direct Transfer CM Service Accept if the UE was in dedicated mode.
4. The UE sends a LCS MO-LR Location Services invoke to the 3G-VMSC. If the UE is requesting its own location or that its own location be sent to another LCS client, this message carries LCS requested QoS information (e.g. accuracy, response time). If the UE is requesting that its location be sent to another LCS client, the message shall include the identity of the LCS client and may include the address of the GMLC through which the LCS client should be accessed. If a GMLC address is not included, the 3G-VMSC may assign its own GMLC address and may verify that the identified LCS client is supported by this GMLC. If a GMLC address is not available for this case, the 3G-VMSC shall reject the location request. If the UE is instead requesting location assistance data or ciphering keys, the message specifies the type of assistance data or ciphering keys and the positioning method for which the

assistance data or ciphering applies. The 3G-VMSC verifies in the UE's subscription profile that the UE has permission to request its own location, request that its location be sent to another LCS client or request location assistance data or deciphering keys (whichever applies). If the UE is requesting positioning and has an established call, the 3G-VMSC may reject the request for certain non-speech call types.

[Editor's note: the description for step 4 above is from 03.71. This functionality is for further study in UMTS.]

5. The 3G-VMSC sends a RANAP Location Reporting Control message to the SRNC associated with the UE's location. The RANAP message indicates whether a location estimate or location assistance data is requested and includes the UE's location capabilities. If the UE's location is requested, the message also includes the requested QoS. If location assistance data is requested, the message carries the requested types of location assistance data..

8.7.1.2 Positioning Measurement Establishment Procedure

6. If the UE is requesting its own location, the actions described under step 9 for a MT-LR are performed. If the UE is instead requesting location assistance data, the SRNC transfers this data to the UE as described in subsequent sections. The SRNC determines the exact location assistance data to transfer according to the type of data specified by the UE, the UE location capabilities and the current cell.

8.7.1.3 Location Calculation and Release Procedure

7. When a location estimate best satisfying the requested QoS has been obtained or when the requested location assistance data has been transferred to the UE, the SRNC returns a RANAP Location Report to the 3G-VMSC. This message carries the location estimate or ciphering keys if this was obtained. If a location estimate or deciphering keys were not successfully obtained or if the requested location assistance data could not be transferred successfully to the UE, a failure cause is included in the Location Report.
8. If the UE requested transfer of its location to another LCS client and a location estimate was successfully obtained, the 3G-VMSC shall send a MAP Subscriber Location Report to the GMLC obtained in step 4 carrying the MSISDN of the UE, the identity of the LCS client, the event causing the location estimate (MO-LR) and the location estimate and its age.
9. The GMLC shall acknowledge receipt of the location estimate provided that it serves the identified LCS client and the client is accessible.
10. The GMLC transfers the location information to the LCS client either immediately or upon request from the client.
11. The 3G-VMSC returns an LCS MO-LR Return Result to the UE carrying any location estimate requested by the UE, ciphering keys or a confirmation that a location estimate was successfully transferred to the GMLC serving an LCS client.
12. The 3G-VMSC may release the CM, MM and RRC connections to the UE, if the UE was previously idle, and the 3G-VMSC may record billing information.

NOTE: In case of positioning of emergency call stage 3 of the previous sequence is naturally omitted.

9 Information storage

9.1 HLR

9.1.1 LCS Data in the HLR for an UE Subscriber

9.2 VLR

9.3 GMLC

9.4 Recovery and Restoration Procedures

10 Operational Aspects

10.1 Charging

10.1.1 Charging Information collected by the PLMN serving the LCS Client

10.1.2 Charging Information Collected by the Visited PLMN

11 History

Date	Version	Comment
August 99	0.0.0	Initial Draft at Sophia Antipolis, France
September 99	0.0.1	Functional descriptions elaborated
September 99	0.1.0	Results from joint meeting R2/S2 21.9.99. Removed parts belonging to UTRAN stage 2 (25.923),
October 99	1.0.0	Identical to 0.1.0, except some editorial modifications.
November 99	1.1.0	Added MAP support for LCS, State descriptions, tentative signaling descriptions
Editor: Jan Kåll Email: jan.kall@nokia.com Telephone: +358400 400056		

DEFINITIONS and terms

ANNEX 1

CAMEL	CAMEL is a network functionality, which provides the mechanisms of Intelligent Network to a mobile user.
Current Location	after a location attempt has successfully delivered a location estimate and its associated time stamp, the location estimate and time stamp is referred to as the 'current location' at that point in time.
Deferred location request	a location request where the location response (responses) is (are) not required immediately.
Global Positioning System.	The Global Positioning System (GPS) consists of three functional elements: Space Segment (satellites), User Segment (receivers), and Control Segment (maintenance etc.). The GPS receiver calculates its own position based on the received time differences for several satellites.
Immediate location request	a location request where a single location response only is required immediately.
Initial Location	in the context of an originating emergency call the location estimate and the associated time stamp at the commencement of the call set-up is referred to as 'initial location'.
Last Known Location	The current location estimate and its associated time stamp for Target UE stored in the LCS Server is referred to as the 'last known location' and until replaced by a later location estimate and a new time stamp is referred to as the 'last known location'.
LCS (LoCation Services)	LCS is a service concept in system (e.g. GSM or UMTS) standardization. LCS specifies all the necessary network elements and entities, their functionalities, interfaces, as well as communication messages, due to implement the positioning functionality in a cellular network. Note that LCS does not specify any location based (value added) services except locating of emergency calls
LCS Client	a software and/or hardware entity that interacts with a LCS Server for the purpose of obtaining location information for one or more Mobile Stations. LCS Clients subscribe to LCS in order to obtain location information. LCS Clients may or may not interact with human users. The LCS Client is responsible for formatting and presenting data and managing the user interface (dialogue). The LCS Client may reside in the Mobile Station (UE).
LCS Client Access barring list	an optional list of MSISDNs per LCS Client where the LCS Client is not allowed to locate any MSISDN therein.
LCS Client Subscription Profile	a collection of subscription attributes of LCS related parameters that have been agreed for a contractual period of time between the LCS client and the service provider.
LCS Feature	the capability of a PLMN to support LCS Client/server interactions for locating Target UEs.
LCS Server	a software and/or hardware entity offering LCS capabilities. The LCS Server accepts requests, services requests, and sends back responses to the received requests. The LCS server consists of LCS components, which are distributed to one or more PLMN and/or service provider.
Local Service	A service, which can be exclusively provided in the current serving network by a Value added Service Provider.
Local Information	Information related to a given location, or general information, which is made available in a given location.
Location (Based)	A location application is an application software processing location information or utilizing it

Application	in some way. The location information can be input by a user or detected by network or UE. Navigation is one location application example.
Location Based Service (LBS)	A service provided either by teleoperator or a 3 rd party service provider that utilizes the available location information of the terminal. Location Application offers the User Interface for the service. LBS is either a pull or a push type of service (see Location Dependent Services and Location Independent Services). In ETSI/GSM documentation of SoLSA, LBS is called "Location Related Service". ETSI and/or 3GPP –wide terminology harmonization is expected here.
Location Dependent Service	A service provided either by teleoperator or a 3 rd party service provider that is available (pull type) or is activated (push type) when the user arrives to a certain area. It doesn't require any subscription in advance, but the push type activation shall be confirmed by the user. The offered service itself can be any kind of service (e.g. a public Xerox machine or the discount list in a store).
Location Estimate	the geographic location of an UE and/or a valid Mobile Equipment (ME), expressed in latitude and longitude data. The Location Estimate shall be represented in a well-defined universal format. Translation from this universal format to another geographic location system may be supported, although the details are considered outside the scope of the primitive services.
Location Independent Service	A service provided either by teleoperator or a 3 rd party service provider that is available and therefore can be activated anywhere in the network coverage. It is activated by the user's request or by other user's activated service, and therefore it requires a subscription in advance (pull type). The offered service itself can be any kind of service (e.g. MMS, SWDL, or LBS!).
Mobile Station	The mobile station (UE) consists of Mobile or User Equipment (ME or UE) with a valid SIM or USIM attached.
PLMN Access barring list	an optional list of MSISDN per PLMN where any LCS Client is not allowed to locate any MSISDN therein except for certain exceptional cases.
Positioning (/location detecting)	Positioning is a functionality, which detects a geographical location (of e.g. a mobile terminal).
Positioning method (/locating method)	A principle and/or algorithm which the estimation of geographical location is based on, e.g. AOA, TOA, TDOA. For example, GPS is based on TOA, and E-OTD (on GSM) is based on TDOA.
Positioning technology (/locating technology)	A technology or system concept including the specifications of RF interfaces, data types, etc. to process the estimation of a geographical location, e.g. GPS, E-OTD (GSM), and IPDL-TDOA (WCDMA).
Predefined area	A geographical area which is not related to cell or radio coverage. The mobile may take special action when it recognises it has entered or left a predefined area.
Privacy Class	list of LCS Clients defined within a privacy exception class to which permission may be granted to locate the target UE. The permission shall be granted either on activation by the target UE or permanently for a contractual period of time agreed between the target UE and the service provider.
Privacy Exception List	a list consisting of various types of privacy classes (i.e. operator related, personal etc.). Certain types of classes may require agreement between the service provider and the target UE.
Prohibited area	An area where the mobile must not activate its transmitter. The Prohibited area may be a Predefined area described above or related to radio cell(s).
Subscription Profile	the profile detailing the subscription to various types of privacy classes.

Target UE	the UE being positioned.
UE	User Equipment