

Overview of 3GPP Release 5

Summary of all Release 5 Features

Credits

This document has been produced by the technical staff of ETSI MCC department, headed by Adrian Scrase, namely: Adrian Zoicas, Alain Sultan, Andrijana Jurisic, Cesar Gutierrez, Claude Arzelier, Claus Dietze, David Boswarthick, Friedhelm Rodermund, Gert Thomasen, Hans van Der Veen (first contributor), John Meredith, Joern Krause, Kimmo Kymalainen, Lidia Salmeron, Maurice Pope, Michael Clayton, Paolo Usai, Per Johan Jorgensen, Tsukasa Sasaki and Sang Ui Yoon. The work was coordinated by Alain Sultan, who wishes to acknowledge the contributors mentioned above for the high quality of their inputs as well as the 3GPP delegates who have sent comments to the draft version of this document.

Contents

1. INTRODUCTION.....	5
1.1. SCOPE.....	5
1.2. REFERENCES.....	5
1.2.1. Specifications.....	5
1.2.2. Tdocs.....	5
1.2.3. Work Plan, Work Items and Study Items.....	6
1.2.4. Change Request database.....	6
2. RELEASE 5 IMPROVEMENTS OF RADIO INTERFACE.....	6
2.1. TDD BASE STATION CLASSIFICATION (FOR 3.84 AND 1.28 MCPS TDD).....	6
2.2. ENHANCEMENT ON THE DSCH HARD SPLIT MODE.....	8
3. RELEASE 5 RAN IMPROVEMENTS.....	8
3.1. RRM OPTIMISATION FOR IUR AND IUB.....	9
3.1.1. Iur common transport channel efficiency optimisation.....	9
3.1.2. Iur neighbouring cell reporting efficiency optimisation.....	9
3.2. RADIO LINK TIMING ADJUSTMENT.....	10
3.3. SEPARATION OF RESOURCE RESERVATION AND RADIO LINK ACTIVATION.....	10
3.4. RE-ARRANGEMENTS OF IUB TRANSPORT BEARERS.....	11
3.5. RAB SUPPORT ENHANCEMENTS FOR REL 5.....	11
3.6. BEAMFORMING REQUIREMENTS FOR UE.....	12
3.7. SUPPORT OF SITE SELECTION DIVERSITY TRANSMISSION IN UTRAN.....	13
3.8. NODE B SYNCHRONISATION FOR 1.28 MCPS TDD.....	13
4. RELEASE 5 EVOLUTIONS OF THE TRANSPORT IN THE UTRAN.....	14
4.1. IP TRANSPORT IN UTRAN.....	14
5. LCS ENHANCEMENTS 1.....	15
5.1. REL-5 LCS ENHANCEMENTS IN GERAN.....	16
5.2. REL-5 LCS ENHANCEMENTS IN UTRAN.....	17
5.2.1. UE Positioning Enhancements for 1.28 Mcps TDD.....	17
5.2.2. Open SMLC-SRNC Interface within the UTRAN to support A-GPS Positioning.....	17
5.3. OTHER LCS IMPROVEMENTS IN REL-5.....	18
6. SECURITY ENHANCEMENTS: NETWORK DOMAIN SECURITY.....	19
7. HIGH SPEED DOWNLINK PACKET ACCESS.....	19
7.1. ARCHITECTURE.....	21
7.2. AMC, ADAPTATIVE MODULATION AND CODING.....	21
7.3. HYBRID ARQ.....	22
8. INTRA DOMAIN CONNECTION OF RAN NODES TO MULTIPLE CN NODES (IUFLEX).....	22
9. UTRAN SHARING IN CONNECTED MODE.....	24
10. IP MULTIMEDIA CN SUBSYSTEM (IMS).....	24
10.1. INTRODUCTION.....	25
10.2. MAIN ENTITIES AND OVERVIEW OF THE BEHAVIOUR.....	25
10.3. CONVERSATIONAL SERVICES AND CODEC ASPECTS.....	26
10.4. OTHER ASPECTS.....	27
11. EXTENDED TRANSPARENT END-TO-END PACKET SWITCHED MOBILE STREAMING APPLICATIONS ("EXTENDED STREAMING").....	27
12. OSA IMPROVEMENTS.....	28

13.	CAMEL PHASE 4	29
14.	MEXE ENHANCEMENTS REL-5.....	30
14.1.	MEXE REL-5 IMPROVEMENTS AND INVESTIGATIONS	30
15.	WIDEBAND ADAPTATIVE MULTI RATE CODEC.....	31
16.	TERMINAL INTERFACES.....	31
16.1.	TERMINAL LOCAL MODEL ENHANCEMENTS.....	32
17.	(U)SIM TOOLKIT ENHANCEMENTS	32
18.	CHARGING AND OAM&P	33
19.	GERAN ENHANCEMENTS.....	34
19.1.	GERAN/UTRAN INTERFACE EVOLUTION 1: EVOLUTION OF IU PS	34
19.2.	GERAN/UTRAN INTERFACE EVOLUTION 2: EVOLUTION OF IU CS	34
19.3.	GERAN INTER BSC NACC IMPROVEMENTS OVER THE Gb INTERFACE	35
19.4.	8PSK AMR HR.....	35
19.5.	GERAN ENHANCEMENTS FOR STREAMING SERVICES 1 & 2	35
19.6.	INTRA DOMAIN CONNECTION OF RAN NODES TO MULTIPLE CN NODES	35
19.7.	LOCATION SERVICES (LCS) FOR GERAN IN A/Gb MODE.....	35
19.8.	ENHANCED POWER CONTROL.....	36
19.9.	ALIGNMENT OF 3G FUNCTIONAL SPLIT AND IU	36
19.10.	GERAN SUPPORT FOR IMS	36
19.11.	FLOW CONTROL SUPPORTING AN MS WITH MULTIPLE DATA FLOWS WITH DIFFERENT QoS OVER THE Gb INTERFACE.....	37
19.12.	OTHER GERAN ASPECTS.....	37
20.	END-TO-END QoS.....	37
21.	MESSAGING ENHANCEMENTS.....	38
21.1.	MULTIMEDIA MESSAGING (MMS) ENHANCEMENTS	39
21.2.	ENHANCED MESSAGING SERVICE (EMS) ENHANCEMENTS.....	39
22.	SERVICE CHANGE AND UDI FALLBACK	40
23.	HANDLING OF EARLY UE.....	41
24.	RELEASE INDEPENDENT FEATURES.....	42
24.1.	UMTS 1800 AND UMTS 1900.....	42
24.2.	GLOBAL TEXT TELEPHONY.....	43
25.	FEATURES NOT BELONGING TO RELEASE 5.....	43

1. Introduction

1.1. Scope

This document contains a high-level description of the 22 Release 5 Features¹ and the 2 Release-Independent Features defined in the Release 5 time frame.

A Feature is defined as new or substantially enhanced functionality which represents added value to the existing system. A feature should normally embody an improved service to the customer and / or increased revenue generation potential to the supplier.

Features are as independent as possible from each other, and relationships between features (if any) are clarified here.

Some features correspond to a grouping of different independent items impacting the same parts of the system (e.g. "Release 5 RAN improvements"). These groupings are performed to artificially limit the total number of features for each Release. For these features, a summary of each item is provided.

For each feature (or independent item), references are given to guide the reader on how to deepen the subject: the Work Item Description (WID) as well as the list of impacted specifications are provided in the beginning of the section describing the feature. Only the list of impacted specifications is provided here. The exact impact on a given specification due to a given feature is described in the Change Request (CR) list, which can be found at the end of the specification, or the CR database provides the full list of CRs for all 3GPP specifications.

The second part of this introduction contains global references, and provides links towards the 3GPP Specifications, the temporary documents (tdocs), the Work Plan, the Work Item Descriptions (WIDs) and the CR database.

The main body of this document is structured according to the 3GPP Release 5 Features: each chapter corresponds to one Release 5 Feature, except for GERAN (see note 1).

1.2. References

1.2.1. Specifications

Global information on the Specifications (also called "specs") can be found at:

<http://www.3gpp.org/specs/specs.htm>

The latest versions of all 3GPP specifications, containing the most recent corrections and additions, are available at:

<http://www.3gpp.org/ftp/Specs/latest/>

For specific purposes, older versions might be needed. These versions are available at:

<http://www.3gpp.org/ftp/Specs/Archive/>

where the specifications are sorted by series and then by folders containing all the available versions of a given spec (one folder per spec), for all Releases.

1.2.2. Tdocs

The Temporary Documents (tdocs) are mainly the original papers written by the 3GPP Members, and are the inputs for elaborating the specs. They are available (sorted by 3GPP technical groups (Technical Specification Groups (TSGs) and Working Groups (WGs)) at:

<http://www.3gpp.org/ftp/>

starting with 'tsg....'.

¹ Officially, they are 36 Features in the 3GPP Release 5 Work Plan but all the GERAN Enhancements were grouped and presented as a single Feature in this document, and "small Technical Enhancements and Improvements for Rel5", "FS on Usage of SUA", and "Technical Report on UE Functionality Split (Work stopped)" are not considered as Features here.

1.2.3. Work Plan, Work Items and Study Items

Work Item Description (“WID”) (also called WI Sheet) and Study Item (also called "Feasibility Studies") are forms which initial version provides the target to be reached before starting the technical work. Potential subsequent versions narrow the target and foreseen completion date according the actual progress. They are stored in:

http://www.3gpp.org/ftp/Information/WI_sheets/

The 3GPP Work Plan is a living document, updated roughly each month, which contains the full list of Work Items and Study Items, as well as summary information for each WI, as: the WG in charge of it, its starting date and (foreseen or actual) completion date, the actual progress, etc. The Work Plan is available at:

http://www.3gpp.org/ftp/Information/WORK_PLAN/

1.2.4. Change Request database

A specification is originally drafted and maintained by a rapporteur, who compiles the contents from discussions in the WGs and TSGs. When it is considered to be 80% complete, it is brought under a so-called "change control" process. After this, changes to the specification can only be made using Change Requests that are usually agreed by consensus in the Working Group responsible for the specification, but then formally approved by the relevant Technical Specification Group².

The Change Request database contains all available information on Change Requests, including a Work Item code, a Change Request number that is unique within the specification (different versions are possible, but only one can ever be approved), the status of each Change Request and references to relevant temporary document numbers and meetings. This database is available in:

http://www.3gpp.org/ftp/Information/Databases/Change_Request/

Further information on CR is available at:

<http://www.3gpp.org/specs/CR.htm>

2. Release 5 Improvements of radio interface

Acronym: RInImp

Unique_ID: 501216

References for WI "Improvements of radio interface"

Document	Title/Contents
RAN_Work_Items	WI Sheet

This feature consists of two independent improvements to the Release 4 radio interface: TDD BS classification and enhancement on the DSCH hard split mode.

2.1. TDD Base station classification (for 3.84 and 1.28 Mcps TDD)

Acronyms: RInImp-BSCClass-TDD (for 3.84 Mcps TDD)

RInImp-BSCClass-LCRTDD (for 1.28 Mcps TDD)

Unique_IDs: 1471, 1477 (TDD), 24002 (LCRTDD)

² For a complete description on the handling of Specs and CRs at 3GPP, see the presentation in: http://www.3gpp.org/MCC/procedures/The_change_control_cycle.ppt

References for WIs "Base Station Classification"

Document	Title/Contents
WIDs	
RAN_Work_Items	WI Sheet "Base station classification"
RAN_Work_Items_History	WI Sheet "TDD base station classification"
RAN_Work_Items_History	WI Sheet "Base station classification for 1.28 Mcps TDD"
RP-020359	Final Status report "TDD base station classification"
RP-020299	Final Status Report "Base station classification for 1.28 Mcps TDD"
RP-020126	Final Status report
Impacted Specifications	
For both TDD and LCRTDD: TS 25.105 TS 25.123 TS 25.142 Only for TDD: TS 25.942 TS 25.952	UTRA (BS) TDD: Radio transmission and reception Requirements for support of radio resource management (TDD) Base Station (BS) conformance testing (TDD) RF system scenarios Base Station classification (TDD)
New Dedicated Specifications	
TR 25.952	"TDD Base Station Classification"
TR 25.882	"1.28 Mcps TDD option BS classification"

Release 99 and Release 4 base station (BS) requirements have been set according to the needs of the macrocell deployment scenario. BS compliant with these specifications are not well suited for microcell and picocell scenarios. This WI studied the particular needs of such scenarios and set new requirements for new BS classes to be used under certain conditions. The work done can be summarised as follows:

- Definition of BS classes according to deployment scenarios.
- Update of some radio parameters, measurement requirements and conformance specifications as listed below.

Work Tasks were identified for the different UTRA modes and chip rates:

- FDD BS Classification
- 3.84 Mcps TDD BS Classification
- 1.28 Mcps TDD BS Classification

3.84 Mcps TDD and 1.28 Mcps TDD are covered in Release 5, whereas FDD BS Classification is part of Release 6.

In TDD, the definition of two classes have been introduced:

- **Wide Area Base Stations.** Characterised by requirements derived from Macro Cell and Micro Cell scenarios with BS to UE coupling losses³ equal to 70 dB and 53 dB. The Wide Area Base Station has the same requirements as the base station for General Purpose application in Release 99 and Release 4
- **Local Area Base Station.** Characterised by requirements derived from Pico Cell scenarios with a BS to UE coupling loss equals to 45 dB.

The following requirements are different now for each class (see TS 25.105, TS 25.123):

- Frequency stability
- Adjacent Channel Leakage Ratio (ACLR)
- Spurious emissions under certain cases of co-existence in the same geographic area with UTRA FDD/TDD
- Receiver sensitivity
- Adjacent Channel Selectivity (ACS)
- Blocking and intermodulation characteristics
- Demodulation of Dedicated CHannel (DCH) in static and multipath conditions (cases 1 and 2 as defined in TS 25.105)
- Dynamic range
- Received Total WideBand Power, Received Signal Code Power (RSCP) measurements range

³ **MCL (Minimum Coupling Loss)** is defined as the minimum distance loss including antenna gain measured between antenna connectors.

2.2. Enhancement on the DSCH Hard Split mode

Acronym: RInImp-DSCHhsp

Unique_ID: 2469

References for WI "Enhancement on the DSCH Hard Split mode"	
Document	Title/Contents
WIDs	
RAN_Work_Items_History	WI Sheet
RP-020126	Final Status report
Impacted Specifications	
TS 25.212 , clause 4.3.4	TFCI coding in DSCH Hard Split mode
TS 25.212	Multiplexing and channel coding (FDD)
TS 25.214	Physical layer procedures (FDD)
TS 25.331	Radio Resource Control (RRC) protocol specification
TS 25.423	UTRAN Iur interface Radio Network Subsystem Application Part (RNSAP) signalling
TS 25.427	UTRAN Iur and Iub interface user plane protocols for DCH data streams
TS 25.433	UTRAN Iub interface NBAP signalling
New Dedicated Specifications	
TR 25.870	Enhancement on the DSCH Hard Split mode

Two limitations of the Downlink Shared CHannel (DSCH) hard split mode as defined in Release 99 in TS 25.212 are resolved by this Work Item:

- When a DSCH is used, its Transport Format Combination Information (TFCI) is sent in the DPCCH (Dedicated Physical Control CHannel) of the associated DCH (Dedicated CHannel). The TFCI field in the DPCCH is shared by the DSCH and the DCH. TFCI size is always 10 bits, and in DSCH hard split mode there is a static allocation of 5 bits to the DSCH and 5 bits to the DCH. This is identified as a limitation, as only 32 TFCI can be coded for DSCH or DCH.
- Logical split is a different split mode in which both TFCIs are concatenated and then coded together. It allows more flexibility in the use of the available TFCI bits, but it cannot be used over the Iur (in soft HO). In split mode of operation, TFCI2 (TFCI for DSCH) is not necessarily transmitted from every cell in the active set when the UE is in soft handover region. In that situation, the combined TFCI power in UE may not be enough to detect it reliably. Also, the power offset for TFCI is determined in Radio Link Setup procedure, and cannot be flexibly changed any longer when a change in the active set occurs. Therefore, there seems to be a reliability problem if the power offset is initially decided a lower value than required, regardless of whether UE is in soft handover or not. To solve this problem in Release 99 and Release 4, the power offset must be always set the highest value even when UE is not in soft handover. This is inefficient in the viewpoint of power resource management. A TFCI power control method could solve these problems.

The solutions for these two limitations of the Hard split mode offered by this Work Item are:

- A new TFCI coding scheme named "Flexible Hard Split mode TFCI" that permits to allocate the available 10 bits in a dynamic manner. This scheme is used for non-split, fixed/flexible split modes, and gives identical output for non-split mode and 5:5 hard split as in Release 99/Release 4;
- A TFCI power control method that adjusts the power offset for TFCI in a flexible manner. This method uses information on whether the User Equipment is in soft handover or whether Site Selection Diversity Transmission is used.

3. Release 5 RAN improvements

Acronym: RANimp

Unique_ID: Several, as listed below

References for WI "RAN improvements"	
Document	Title/Contents
RAN_Work_Items	WI Sheet

This feature consists of a collection of independent improvements to the Release 4 Radio Access Network presented in the following sub-sections.

3.1. RRM optimisation for lur and lub

Acronym: RANimp-RRMopt

Unique_ID: 656

References for WI "RRM optimisation for lur and lub"

Document	Title/Contents
WIDs	
RAN_Work_Items_History	WI Sheet
Impacted Specifications	
TS 25.423	UTRAN lur interface Radio Network Subsystem Application Part (RNSAP) signalling
New Dedicated Specifications	
	None

This Work Item allows to optimise the existing procedures and functions on the Iub and Iur interfaces. It contains two independent Work Tasks, described in the two following sub-sections.

3.1.1. lur common transport channel efficiency optimisation

Acronym: RANimp-RRMopt-ctc

Unique_ID: 23000

Table 4.1.1.1: References for WI "lur Common Transport Channel Efficiency Optimisation"

Document	Title/Contents
WIDs	
RAN_Work_Items_History	WI Sheet
RP-020209	Final Status report
Impacted Specifications	
TS 25.423	UTRAN lur interface RNSAP signalling
New Dedicated Specifications	
R3.002	Internal TR on lur Common Transport Channel Efficiency Optimisation ⁴

In Release 99 and Release 4, each time the UE moves from one cell to another cell in the same RNS, a procedure is required in some states to provide the SRNC with some information that often stays the same, because the RNS is the same.

The Work Item provides a possibility for the RNS to indicate that the procedure is not required as far as it is concerned, so that the procedure is executed only when necessary⁵.

3.1.2. lur neighbouring cell reporting efficiency optimisation

Acronym: RANimp-RRMopt-ncr

Unique_ID: 23001

⁴ The latest version (v.1.0.0) of this document can be found as R3-020815 in:

ftp://ftp.3gpp.org/tsg_ran/WG3_lu/R3_internal_TRs/R3.002_lur_comTrCH_efficiency/

⁵ More precisely: currently in RACH/FACH state, the SRNC will have to execute the RNSAP Common Transport Channel Resources Initialisation procedure every time the UE moves from one cell to another cell in the same DRNS. This procedure is required to provide the SRNC with some information that, in most of the cases, remains invariable as the DRNS is the same. A mechanism is introduced to reduce the need for a Common Transport Resources Initialisation procedure where possible: with this WI, the DRNC is given the possibility to inform the SRNC that as far as the DRNC is concerned, it does not require a Common Transport Channel Resources Initialisation procedure to be performed if the UE remains in CELL-FACH state. The solution is implemented with a new IE in the Uplink Signalling Transfer message from the DRNC to the SRNC.

Table 4.1.2.1: References for WI "Iur Neighbouring cell reporting efficiency optimisation"

Document	Title/Contents
WIDs	
RAN_Work_Items_History	WI Sheet
RP-020151	Final Status report
Impacted Specifications	
TS 25.423	UTRAN Iur interface RNSAP signalling
New Dedicated Specifications	
TR 25.884	"Iur Neighbouring cell reporting efficiency optimisation"

In Release 99 and Release 4, every time a radio link is established within a cell, information about certain characteristics of neighbouring cells is provided to the SRNC regardless of whether it has received this information before.

This Work Item provides a mechanism that avoids the transport of information of which the SRNC is already aware. The mechanism groups indicators of the cell's characteristics and capabilities in a common Cell Capability Container, optimising the size increase for Release 5 and later releases.

3.2. Radio link timing adjustment

Acronym: RANimp-RLTA

Unique_ID: 2488

References for WI "Radio Link Timing Adjustment"	
Document	Title/Contents
WIDs	
RAN_Work_Items_History	WI Sheet
RP-020138	Final Status report
Impacted Specifications	
TS 25.423	UTRAN Iur interface RNSAP signalling
TS 25.433	UTRAN Iub interface NBAP signalling
TS 25.331	Radio Resource Control (RRC) Protocol Specification
New Dedicated Specifications	
TR 25.878	"Radio Link Timing Adjustment"

The transmission timing of a radio link relates to the time between reception of the downlink DPCH and transmission of uplink DPCH. In the physical layer and layers 2 and 3 specifications, mechanisms for the adjustment of this timing have been defined for Release 99 and Release 4. However, there is no RNSAP nor NBAP message which contains any information about DL timing adjustment and therefore it is not possible for the SRNC to use the mechanisms in place and to adjust the DL timing of a DPCH.

This work item allows to execute a timing adjustment of one individual RL, typically one of several RLs in the active set. After two alternative solutions were studied, it was finally decided that timing adjustment is done by means of DL timing corrections only (and not combined DL and UL). The UE timing is not drifted, only the NodeB whose radio link gets out of the UE receiving window has its timing adjusted. Since DL timing mechanisms are currently in place in Release 99 RRC specification, mainly the RNSAP and NBAP protocols were impacted (some small changes were also required on the RRC protocol).

3.3. Separation of resource reservation and radio link activation

Acronym: RANimp-SepRR

Unique_ID: 2489

References for WI "Separation of resource reservation and radio link activation"

Document	Title/Contents
WIDs	
RAN_Work_Items_History	WI Sheet
RP-020141	Final Status report
Impacted Specifications	
TS 25.423	UTRAN Iur interface Radio Network Subsystem Application Part (RNSAP) signalling
TS 25.433	UTRAN Iub interface NBAP signalling
New Dedicated Specifications	
TR 25.879	"Separation of resource reservation and radio link activation"

In Release 99 and Release 4, the reservation of dedicated resources in the UTRAN is linked to the RF transmission on the corresponding radio links. This Work Item introduces a mechanism to activate/deactivate radio transmission independently of the reservation of resources in the network.

Although being one of the motivations of this WI, the final implementation doesn't allow to reserve resources in the network without allocating them to a particular UE, so allocation is still done at the reservation and not at the activation.

3.4. Re-arrangements of Iub transport bearers

Acronym: RANimp-TTPS (previous name: "Traffic Termination Point Swapping")

Unique_ID: 2491

References for WI "Re-arrangement of Iub Transport Bearers"

Document	Title/Contents
WIDs	
RAN_Work_Items_History	WI Sheet
RP-020144	Final Status report
Impacted Specifications	
TS 25.430	UTRAN Iub Interface: General Aspects and Principles
TS 25.433	UTRAN Iub interface NBAP signalling
New Dedicated Specifications	
TR 25.880	"Re-arrangement of Iub Transport Bearers"

Two problems were identified concerning bearer allocation in Release 99 and Release 4:

- There is no mechanism to change signalling bearer once it has been selected at the creation of the Node B Communication Context;
- There is no mechanism to switch the existing transport bearers from one physical termination point to another.

To solve these problems, this Work Item modifies the existing Radio Link reconfiguration procedure and introduces a new procedure "Iub Bearer Re-Arrangement Indication". This allows distributed physical resources to be used more efficiently by switching existing transport bearers from one physical termination point to another. The solution also allows balancing of the transport resources between the segments of the Node B transport resource pool.

3.5. RAB support enhancements for Rel 5

Acronym: RANimp-RABSE5

Unique_ID: 22000

References for WI "Radio Access Bearer Support Enhancements"

Document	Title/Contents
WIDs	
RAN_Work_Items_History	WI Sheet
RP-020343	Final Status report
Impacted Specifications	
TS 25.331	Radio Resource Control (RRC) protocol specification
TS 25.413	UTRAN Iu interface Radio Access Network Application Part (RANAP) signalling
TS 25.303	Interlayer procedures in Connected Mode
TS 25.306	UE Radio Access capabilities definition
TS 25.323	Packet Data Convergence Protocol (PDCP) specification
TS 25.331	Radio Resource Control (RRC) protocol specification
New Dedicated Specifications	
TR 25.860	"Radio Access Bearer Support Enhancements"

Under this general Work Item, different changes are introduced in different releases. The Release 5 part introduces the required changes to perform RFC3095 context relocation in the SRNS context relocation.

RFC3095 "RObust Header Compression (ROHC)" is the IETF proposal for IP header compression specially designed for real time IP services over wireless links. ROHC is currently part of the Release 4 of UTRAN as one of the compression schemes to be provided by the PDCP sublayer in the RNC.

As ROHC is part of the PDCP layer, there is a compressor and decompressor pair in the RNC and a corresponding pair in the UE. During SRNS relocation the source RNC gives the role of the serving RNC (SRNC) to the target RNC, therefore compressor/decompressor have to be relocated as well.

The straightforward solution currently in place in Release 4 has been to initialise the header compression in both peers after relocation, which results in problems like high probability of lost speech frames. This could be avoided by not initialising compression but continuing it in the target SRNC from the place in which the compression ended in the source SRNC.

In order to perform the ROHC relocation, RANAP messages that carry RAB contexts during SRNS relocation are updated to carry also the ROHC/RFC3095 contexts for each RAB. The ROHC context IE to be transferred is defined in the RRC protocol specification. "RFC3095 Context Info" container to RANAP information elements "Forward SRNS Context" and "RANAP Relocation Information" were added to RANAP.

3.6. Beamforming requirements for UE

Acronym: RANimp-BFR-UE and RANImp-BeamF

Unique_ID: 21001

References for WI "Beamforming requirements for UE"

Document	Title/Contents
WIDs	
RAN_Work_Items_History	WI Sheet
RP-010800	Final Status report
Impacted Specifications	
TS 25.101	User Equipment (UE) radio transmission and reception (FDD)
TS 25.133	Requirements for support of radio resource management (FDD)
New Dedicated Specifications	
	None

Beamforming with dedicated pilot symbols or with S-Common Pilot Channel has the potential to improve system capacity. Beamforming antennas consist of an array of antennas used to form one or several beams within a cell with controlled beam directions.

This Work Item defines the UE performance requirements for efficient support of beamforming, including active set size limitation and performance requirement for a dedicated pilot.

A separate Work Item (Beamforming enhancements) is dedicated to the use of beamforming in UTRAN, but this is not part of Release 5.

3.7. Support of Site Selection Diversity Transmission in UTRAN

Acronym: RANimp-SSDT

Unique_ID: 21002

References for WI "SSDT support in UTRAN"

Document	Title/Contents
WIDs	
RAN_Work_Items_History	WI Sheet
RP-020356	Final Status report
Impacted Specifications	
TS 25.104	Base Station (BS) radio transmission and reception (FDD)
TS 25.141	Base Station (BS) conformance testing (FDD) Physical layer procedures (FDD)
TS 25.214	UTRAN Iur interface Radio Network Subsystem Application Part (RNSAP) signalling
TS 25.423	UTRAN Iub interface NBAP signalling
TS 25.433	UTRAN Iub interface NBAP signalling
New Dedicated Specifications	
	None

In Soft Hand Over, a UE keeps a radio link (downlink and uplink) with a group of cells at the same time. This group is termed "Active Set". However, having several Node Bs transmitting to one UE might not be beneficial for the system as a whole, as it increases interference to other users. In Site Selection Diversity Transmission (SSDT) operation, the UE reports the cell that it receives better (Primary), and the other cells stop transmitting the data in the DPDCH. They continue however listening since they may need to change the state to Primary at any time, and they also keep transmitting the control channel (DPCCH).

To change its state, the Node B uses a parameter labeled Qth (quality threshold) determined by upper layers, together with the target SIR and the uplink DPCH SIR.

In the Release 99 and Release 4 specifications, it is assumed that the Qth parameter in Node B is set as an OAM parameter with vendor specific definition and signaling ranges. However, support of Qth parameter over NBAP is needed for multi-vendor NodeBs and hence full support of SSDT on the UTRAN side. In addition, the physical quantity (UTRAN measurement) used in combination with the Qth parameter is not defined in TS 25.214 specification, and performance requirements for the Node B are missing.

In summary, the WI results in the following:

- The Qth parameter and physical measurement quantity at Node B are specified
- Performance requirements for correct operation of the SSDT functionality at the Node B
- The necessary signalling of the Qth parameter over the Iub and Iur interfaces is specified

It has to be reminded that SSDT support is mandatory in Release 99 UEs, the changes introduced with this WI ensure the functionality in the network, but no new concept is included; it is SSDT in the same form as defined in Release 99.

3.8. Node B Synchronisation for 1.28 Mcps TDD

Acronym: RANimp-NBSLCR

Unique_ID: 2472

References for WI "Node B Synchronisation for 1.28 Mcps TDD"

Document	Title/Contents
RAN_Work_Items_History	WI Sheet
RP-020201	Final Status report
Impacted Specifications	
TS 25.402	Synchronisation in UTRAN Stage 2
TS 25.433	UTRAN Iub interface NBAP signalling
TS 25.224	Physical layer procedures (TDD)
TS 25.225	Physical layer; Measurements (TDD)
New Dedicated Specifications	
TR 25.868	"Node B Synchronisation for 1.28 Mcps TDD"

In Release 4, a Synchronisation Port in 3.84 Mcps TDD Node Bs was standardised to minimise cross-interference in neighbouring cells and to enable cell synchronisation by means internal to UTRAN, such as signalling via the air interface.

This Work Item provides a similar synchronisation method for 1.28 Mcps TDD, which differs from the Release 4 method in that it uses the Downlink Pilot CHannel (DwPCH) rather than the Physical Random Access CHannel (PRACH) that is used for 3.84 Mcps TDD.

4. Release 5 evolutions of the transport in the UTRAN

Acronym: ETRAN

Unique_ID: Several, as listed below

References for WI "Evolutions of the transport in the UTRAN"

Document	Title/Contents
RAN_Work_Items	WI Sheet

This feature was designed as a collection of independent improvements to the Release 4 transport in the UTRAN. At the end of Release 5, it appears that the collection was reduced to one single item, "IP Transport in UTRAN" described below. However, as to avoid purely administrative work, the structure was kept as such.

4.1. IP Transport in UTRAN

Acronym: ETRAN-IPtrans

Unique_ID: 625

References for WI "IP Transport in UTRAN"

Document	Title/Contents
RAN_Work_Items_History	WI Sheet
RP-020135	Final Status report
Impacted Specifications	
TS 25.401	UTRAN Overall Description
TS 25.410	Iu General Aspects & Principles
TS 25.411	UTRAN Iu Interface Layer 1
TS 25.412	UTRAN Iu Interface Signalling Transport
TS 25.413	UTRAN Iu Interface RANAP Signalling
TS 25.414	UTRAN Iu interface data transport and transport signalling
TS 25.415	UTRAN Iu interface user plane protocols
TS 25.420	UTRAN Iur Interface General Aspects and Principles
TS 25.422	UTRAN Iur Interface Signalling Transport
TS 25.423	UTRAN Iur interface RNSAP signalling
TS 25.424	UTRAN Iur Interface Data Transport & Transport Signalling for Common Transport Channel Data Streams
TS 25.426	UTRAN Iur and Iub interface data transport & transport signalling for DCH data streams
TS 25.430	UTRAN Iub Interface: General Aspects and Principles
TS 25.432	UTRAN Iub Interface: Signalling Transport
TS 25.433	UTRAN Iub interface NBAP signalling
TS 25.434	UTRAN Iub Interface Data Transport and Transport Signalling for Common Transport Channel Data Streams
TS 25.442	UTRAN Implementation Specific O&M Transport
New Dedicated Specifications	
TR 25.933	IP Transport in UTRAN

In Release 99 and Release 4, only ATM can be used at the transport layer in the various interfaces.

This Work Item introduces the possibility to use IP at the transport layer in the Iub, Iur, Iu-Ps and Iu-Cs interfaces, as an alternative to ATM. However, the use of ATM at the link layer under IP is not precluded.

The introduction of IP as a transport protocol in the radio network does not imply an end to end IP network; the UE may be given an IP address by the higher layers, but it will not be part of the UTRAN IP network (which is private), and packets will be encapsulated in the corresponding User Plane protocol.

The Work Item has made a choice for the protocols to transport the Radio and Signalling bearers over IP. Different solutions are adopted: UDP is used in the User plane in the three interfaces, and SCTP with additional protocols is used for the Signalling bearers. With respect to the IP version, IPv6 is mandatory and IPv4 is optional, although a dual stack is recommended.

Additionally, the Work Item resulted in decisions on QoS and interworking with ATM transport networks:

- Diffserv is the mechanism to provide different service levels, and several alternatives are allowed for the traffic flow classification. It is allowed also that the QoS differentiation can be provided either on a hop-by-hop basis or on an edge-to-edge basis;
- Interworking with Release 99/Release 4 and Release 5 ATM nodes is required, and it can be accomplished via a dual stack, a logical interworking function or a separate InterWorking unit.

5. LCS enhancements 1

Acronym: LCS1

Unique_ID: Several, as listed in the following sub-sections

This feature consists of a collection of independent improvements to the Release 4 Location Services.

The main improvements can be classified in three categories:

- the ones linked to GERAN: the location is now possible for the GERAN when the Iu is used for circuit switch (CS) and packet switch (PS) modes, as well as when the Gb is used (for PS mode). The official WI names are:
 - Location Services for GERAN in A/Gb Mode

- Location Services for GERAN in Iu Mode
- LCS interoperation stage 2 aspects/LCS interoperability aspects to GERAN
- the ones linked to UTRAN:
 - UE Positioning Enhancements for 1.28 Mcps TDD
 - Open SMLC-SRNC Interface within the UTRAN to support A-GPS Positioning
- the other ones (linked to service aspects, to CN aspects, and to other general aspects):
 - Specification for the Le Interface between the external client and the network.
 - Event driven deferred LCS request, also referred as Event based and Periodic LCS.
 - Enhanced support for user privacy and subscriber data handling (which concluded in providing a TR).
 - OAM and feasibility studies as detailed in the corresponding sub-section.

5.1. Rel-5 LCS enhancements in GERAN

Acronyms: Location Services for GERAN in A/Gb Mode: LCS-GERAB
 Location Services for GERAN in Iu Mode: LCS-GERIU
 LCS interoperability aspects to GERAN: LCS-INTF

Unique_IDs: LCS-GERAB: 2436
 LCS-GERIU: 2442
 LCS-INTF: 2434

References for WI "Rel-5 LCS enhancements in GERAN"

Document	Title/Contents
WIDs	
GP-011925	Location Services for GERAN in A/Gb Mode
GP-011926	Location Services for GERAN in Iu Mode
GP-000456	LCS interoperability aspects to GERAN
Impacted Specifications	
TS 43.059	Functional stage 2 description of Location Services (LCS) in GERAN
TS 44.031	Mobile Station (MS) Serving Mobile Location Centre (SMLC) Radio Resource LCS Protocol (RRLP)
TS 44.071	Mobile radio interface layer 3 Location Services (LCS) specification
TS 49.031	Base Station System Application Part LCS Extension (BSSAP-LE)
TS 23.271	Functional stage 2 description of LCS
New Dedicated Specifications	
	None

The purpose of these work items is to enhance GERAN LCS. As listed above, the two main items are:

- LCS for GERAN in A/Gb mode: LCS support on packet-data channels and over the A/Gb interface. This encompasses the introduction of LCS in packet switched GERAN, including similar services as in circuit switched GSM, with reasonably small amount of changes to the existing GPRS specifications. Backward compatibility with GSM LCS Rel98 and Release 99 BSS architecture is offered.
- LCS for GERAN in Iu mode: this introduces LCS support over the Iu-ps, Iu-cs, Iur-g interfaces.

The third item is an administrative tool and not an added functionality. It is:

- LCS interoperation stage 2 aspects/LCS interoperability aspects to GERAN. This WI was just used to incorporate GERAN aspects into TS 23.271 (Stage 2 for LCS, Core Network, handled by SA2). Indeed, TS 43.059 (handled by GERAN) specifies stage 2 of LCS in GERAN, whereas the LCS entities and operations within the Core Network are specified in TS 23.271, whatever GERAN or UTRAN is used in the access network. So some alignments were needed in 23.271. After exchange of info by LSs between SA2 and GERAN, it appeared that no major discrepancies were found between GERAN and SA2 work.

The same positioning methods are supported by GERAN LCS as in earlier release, i.e. Timing Advance (TA), Enhanced Observed Time Difference (E-OTD), and Global Positioning System (GPS).

5.2. Rel-5 LCS enhancements in UTRAN

Acronym: LCS1-UEpos
Unique_ID: 1600

It consists in the two items described in the two following sub-sections.

5.2.1. UE Positioning Enhancements for 1.28 Mcps TDD

Acronym: LCS-128Pos
Unique_ID: 2474

References for WI "UE positioning enhancements for 1.28 Mcps TDD"

Document	Title/Contents
RAN_Work_Items_History	WI Sheet
RP-020088	Final Status report
TR 25.859	"UE positioning enhancements for 1.28 Mcps TDD"
Impacted specifications	
TS 25.224	Physical layer procedures (TDD)
TS 25.225	Physical layer; Measurements (TDD)
TS 25.302	Services provided by the physical layer
TS 25.305	User Equipment (UE) positioning in Universal Terrestrial Radio Access Network (UTRAN); Stage 2
TS 25.331	Radio Resource Control (RRC) protocol specification
TS 25.423	UTRAN Iur interface Radio Network Subsystem Application Part (RNSAP) signalling
TS 25.433	UTRAN Iub interface NBAP signalling
New Dedicated Specifications	
	None

This Work Item introduces two positioning methods to be used with 1.28 Mcps TDD:

- Observed Time Difference Of Arrival (OTDOA): Same principle as OTDOA for FDD and 3.84 Mcps TDD. The measurement for OTDOA position estimation is the 'SFN – SFN' (System Frame Number) observed time difference between cell transmissions;
- Angle of Arrival (AOA). Based on the sector that the Node B is using to receive and transmit to the UE, the location region can be estimated. The method can be further improved when adaptative antennae are used, which is a proposed feature for 1.28 Mcps TDD.

5.2.2. Open SMLC-SRNC Interface within the UTRAN to support A-GPS Positioning

Acronym: LCS-INTF
Unique_ID: 2125

References for WI "Open SMLC-SRNC Interface within the UTRAN to support A-GPS Positioning"

Document	Title/Contents
RAN_Work_Items_History	WI Sheet
RP-010639	Final Status report
Impacted specifications	
TS 25.450	"UTRAN I _{upc} Interface: General Aspects and Principles"
TS 25.451	"UTRAN I _{upc} Interface: Layer 1"
TS 25.452	"UTRAN I _{upc} Interface: Signalling Transport"
TS 25.453	"Positioning Calculation Application Part (PCAP)"
TS 25.401, TS 25.305	Stage 2 of LCS in UTRAN
New Dedicated Specifications	
	None

For A-GPS positioning, there is sufficient functional separation from RNC functions to justify a separate interface towards a StandAlone SMLC (SAS). This Work Item provides support for an open interface between the SAS and the SRNC limited to the support of A-GPS positioning, the I_{upc} interface. This new interface is analogous to the I_b interface defined in the GSM LCS specifications, except that the positioning messages are terminated at the

SRNC and mapped to Release 99 RRC messages and that the positioning messages also support broadcast of LCS assistance data in support of the RRC broadcast messages.

An SAS is an optional network element⁶ that performs the following procedures:

- Provide GPS assistance data to the RNC, for both UE-assisted and UE-based method types, to be delivered through point-to-point or broadcast channels to UE;
- Act as a location calculation server if the location estimates are not to be calculated in the RNC.

The Iupc interface is used to forward UE Positioning assistance data to UEs and to receive UE Positioning measurement data from the RNC.

When timing assistance is needed, the SAS relies on the RNC (and on the possibility to have GPS receivers co-located with the RNC, the Node Bs and/or present in the UEs) to obtain that.

The Iupc interface uses an Iups-like protocol stack for the transport layer.

5.3. Other LCS improvements in Rel-5

Main Acronyms: Event based and Periodic LCS : LCS1-EBP
Specification for the Le Interface: LCS1-Le

Mains Unique_IDs: LCS1-EBP: 1171
LCS1-Le: 32011

References for WI "Location Services enhancements"

Document	Title/Contents
WIDs	
SP-010518	WID for LCS in Rel-5
Impacted Specifications	
TS 22.071	LCS - Stage 1
TS 23.271	LCS - Stage 2
New Dedicated Specifications	
	None

- Event driven deferred LCS request: Event-driven LCS is included in release 4: it enables to determine the position of a mobile when it becomes active in the network. Release 5 combines Event driven and Periodic LCS: with this improvement, Periodic and event-based location reports can be requested and handled simultaneously by the GMLC and the MSC/SGSN.
- Standardisation of the Le interface: the Le interface between the external LCS client and the network's GMLC is specified in this Release by a reference towards Location Interoperability Forum documentation (now under OMA). For the former Releases, the communications between external client and the network were done with proprietary solutions.
- Enhanced support for user privacy and subscriber data handling. Three new services are introduced: "Requestor" (the identity of the originating entity which has requested the location of the target UE from the LCS client) is sent to the UE, "Codeword" (a secret word defined by the target user to authorise to requestor to get the location), and "Service Type" (an indication of the purpose of the LCS request: LCS clients are classified into different Service Types -e.g. "Navigation", "Public Safety Services"- and only certain types can be authorised to get the target's location). A Technical Report was elaborated for this purpose (TR 23.871), which concluded that all these three concepts have been handled and included in Release 5 LCS stage 2 TS 23.271 by means of CR providing minor functional requirements on the existing architecture, without any need of new architecture. Other aspects described in the TR are introduced only in Rel-6: to perform the privacy check in the home GMLC/PPR rather than in the core network (MSC/SGSN), or the support for anonymity (enabling to use of pseudonym instead of the MSISDN).

Other more generic LCS-related matters handled in Release 5 are:

- GERAN MS Conformance test for LCS
- GERAN BTS Conformance test for LCS

⁶ "optional" means that the function is not necessarily embedded in a stand-alone entity and can also be performed by the SRNC. In other terms, the addition of this interface does not preclude the A-GPS to be supported in the SRNC.

- Charging and OAM&P for LCS enhancements (impacts 32.101 and 32.102 for general OAM aspects, and 32.205 and 32.215 for charging aspects).

6. Security enhancements: Network Domain Security

Acronym: SEC1-NDS

Unique_ID: 1576

References for WI "Network Domain Security"

Document	Title/Contents
WIDs	
SP-000420 ⁷	Network Domain Security
Impacted Specifications	
TS 33.102	3G Security; Security architecture
TS 33.103	3G Security; Integration Guidelines ⁸
TS 33.105	3G Security; Cryptographic Algorithm Requirements
New Dedicated Specifications	
TS 33.210	3G Security; Network Domain Security; IP network layer security

This WI consists of the stage-2 specification for IP-related security in the UMTS core network. These "Security services" are confidentiality, integrity, authentication and anti-replay protection.

They are actually ensured by standard procedures, based on cryptographic techniques.

The WI also defines the security architecture for the UMTS network IP based control plane, covering the control signalling on selected interfaces between UMTS network elements.

It was identified that 3G systems should provide enhanced security over 2G systems in the area of SS7 network security due to the increased threats linked to the predicted larger Multi-Operator environment. Important SS7 MAP signalling has now been protected in 3G systems. The associated Automatic Key Management mechanisms were not completed due to missing interfaces and protocols in the Core Network Specifications.

7. High Speed Downlink Packet Access

Acronyms: Global acronym: HSDPA

Unique_ID: HSDPA: 2476

⁷ This Feature was originally targeted for Release 4, but was not completed in the Core Network and subsequently moved to Release 5. It kept its original number given during the year 2000.

⁸ 33.103 and 33.105 do not appear in Release 5. They have to be added.

References for WIs "High Speed Downlink Packet Access"

Document	Title/Contents
RAN_Work_Items_History	WI Sheet "Physical layer"
RAN_Work_Items_History	WI Sheet "Layer 2 and 3 aspects"
RAN_Work_Items_History	WI Sheet "Iub/Iur aspects"
RAN_Work_Items	WI Sheet "High Speed Downlink Packet Access"
RAN_Work_Items	WI Sheet "RF Radio Transmission/ Reception, System Performance Requirements and Conformance Testing"
RP-020505	Latest Status report
Impacted specifications	
HSDPA-Iub/Iur: TS 25.401 TS 25.420 TS 25.423 TS 25.425 TS 25.430 TS 25.433 TS 25.435 TS 25.877 TS 25.931 HSDPA-Iur/Iub: TS 25.413 HSDPA-L23: TS 25.301 TS 25.302 TS 25.306 TS 25.308 TS 25.321 TS 25.322 TS 25.331 HSDPA-Phys: TS 25.201 TS 25.211 TS 25.212 TS 25.213 TS 25.214 TS 25.215 TS 25.221 TS 25.222 TS 25.223 TS 25.224 TS 25.225 TS 25.306 HSDPA-RF: TS 25.101 TS 25.102 TS 25.104 TS 25.123 TS 25.141 TS 25.142	UTRAN overall description UTRAN Iur Interface: General Aspects and Principles UTRAN Iur interface Radio Network Subsystem Application Part (RNSAP) signalling UTRAN Iur interface user plane protocols for CCH data streams UTRAN Iub Interface: General Aspects and Principles UTRAN Iub interface NBAP signalling UTRAN Iub interface user plane protocols for CCH data streams High Speed Downlink Packet Access (HSDPA) - Iub/Iur Protocol Aspects UTRAN Functions, examples on signalling procedures UTRAN Iu interface Radio Access Network Application Part (RANAP) signalling Radio Interface Protocol Architecture Services provided by the physical layer UE Radio Access capabilities definition UTRA High Speed Downlink Packet Access (HSDPA); Overall description; Stage 2 Medium Access Control (MAC) protocol specification Radio Link Control (RLC) protocol specification Radio Resource Control (RRC) protocol specification Physical layer - general description Physical channels and mapping of transport channels onto physical channels (FDD) Multiplexing and channel coding (FDD) Spreading and modulation (FDD) Physical layer procedures (FDD) Physical layer; Measurements (FDD) Physical channels and mapping of transport channels onto physical channels (TDD) Multiplexing and channel coding (TDD) Spreading and modulation (TDD) Physical layer procedures (TDD) Physical layer; Measurements (TDD) UE Radio Access capabilities definition User Equipment (UE) radio transmission and reception (FDD) User Equipment (UE) radio transmission and reception (TDD) Base Station (BS) radio transmission and reception (FDD) Requirements for support of radio resource management (TDD) Base Station (BS) conformance testing (FDD) Base Station (BS) conformance testing (TDD)
New Dedicated Specifications	
TR 25.308	"HSDPA Overall description, Stage 2"
TR 25.858	"HSDPA Physical layer aspects"
TR 25.877	"HSDPA Iur/Iub protocol aspects"

High Speed Downlink Packet Access (HSDPA) is a feature based on a downlink shared channel, data only, that allows data rates of up to 10 Mb/s. It is designed to support services that require instantaneous high rates in the downlink and lower rates uplink (also called "reverse link"). This feature also allows to decrease the level of retransmissions (at the Radio Link and hence higher layers), in turn allowing the reduction of delivery time. Examples of end-user services using HSDPA are Internet browsing and video on demand.

The HSDPA feature in Release 5 is the result of a study carried out in the Release 4 time frame. This study considered a number of techniques in order to provide instantaneous high speed data in the downlink. Some of the considerations taken into account in the evaluation of the different techniques were:

- to focus on the streaming, interactive and background services.
- to prioritise urban environments and then indoor deployments (but not limited to these environments and supporting full mobility).
- to enable compatibility with advanced antenna and receiver techniques.
- to take into account User Equipment processing time and memory requirements.
- to minimise changes on existing techniques and architectures.

The following technologies were evaluated:

- Adaptative Modulation and Coding schemes (AMC)
- Hybrid Automatic Retransmission Query (Hybrid ARQ)
- Fast Cell Selection (FCS)
- Multiple Input Multiple Output antenna processing (MIMO)
- Standalone Downlink Shared CHannel (Standalone DSCH)

AMC and Hybrid ARQ are the basis of Release 5 HSDPA. MIMO is under study for introduction in Release 6, and FCS and Standalone DSCH have been currently discarded but may be adopted for a longer term evolution.

7.1. Architecture

The new high speed access is based on the new High Speed-Downlink Shared CHannel (HS-DSCH) transport channel, which keeps some of the characteristics of the Release 99 DSCH. It is defined for FDD and both TDD modes. It is a time shared channel, mapped to one or more physical data channels. A new physical downlink data channels is defined (HS-PDSCH), together with an associated downlink control channel for layer 1 signalling (HS-SCCH) . An uplink signalling channel is also required, HS-DPCCH, based in the standard DPCCH.

One of the main characteristics of HSDPA is the link adaptation: the transmission scheme changes every Transmission Time Interval to adapt to the radio link conditions.

The new functionality of hybrid ARQ and HSDPA scheduling are included in a Medium Access Control (MAC) layer. In the UTRAN these functions are included in a new entity called MAC-hs, which is terminated in Node B. Two protocol configurations are possible, with or without MAC c/sh. The diagram below shows the architecture for the the first configuration:

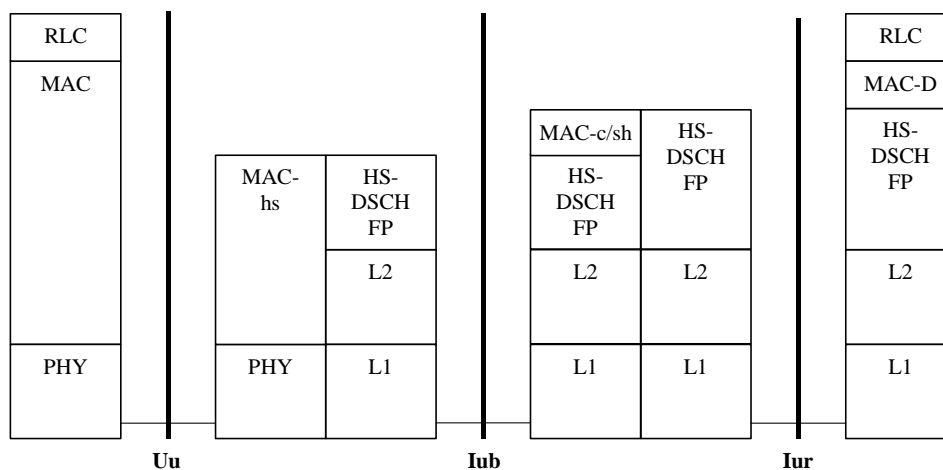

Figure 7.1: HSDPA protocol architecture with MAC c/sh

The basic transport channel configuration consists of a HS-DSCH, and an associated DPCH.

In the downlink, the associated DPCH carries a HS-DSCH Indicator (HI) pointing to the shared control channel the User Equipment (UE) needs to decode. Whenever the UE has to decode one or more HS-DSCH TTIs, the HS-SCCH channels pass the UE of the channelisation codes used in the HS-DSCH TTIs and additional information signalling.

The spreading factor of the HS-PDSCH is fixed to 16 (SF=1 also possible in TDD mode), and many HS-PDSCH can be used code-multiplexed, to different UEs or a single multi-code capable UE.

The uplink signalling consists of the acknowledgements for the Hybrid ARQ and information of channel conditions. The HS-DPCCH is used with the same spreading and modulation as a DPCH.

Various UE reference capability combinations are defined, ranging from 1.2 Mbps to 10 Mbps. Each of these reference combinations will have to support a number of HS-DSCH categories (up to 38 for 3.84 Mcps TDD) that specify the number of codes per timeslot, the minimum inter-TTI interval (FDD), the spreading factor 1 capability (TDD) and other characteristics.

7.2. AMC, adaptative modulation and coding

HSDPA uses link adaptation with several predefined combinations of modulation and channel coding. The Node B selects the modulation and the coding for each TTI for each user based on an estimate of the downlink. The UE reports in the uplink signalling a measurement of the downlink. Higher order modulations (16 Quadrature Amplitude Modulation and) will be used in good radio link conditions, lower schemes (Quadrature Phase Shift Keying and) will be used in poor radio conditions to maintain the error rate.

With a good scheduling function in the Node B, the global system bit rate can be optimised based on the particular radio link conditions of each user. This is a different in Release 99 DSCH, which had the scheduler in the RNC. This architecture would introduce too much delay for the scheduler to benefit from the link adaptation, therefore it was decided it should be moved to the Node B.

The AMC performance is very much dependent on an accurate and well-timed estimation of the link conditions for each user. As a channel estimation, the UE will report the Channel Quality Indicator (CQI). CQI is defined as the transport format the UE can receive with a Packet Error Ratio of 0.1 for the current relation between the Common Pilot Channel power and the HS-DSCH power.

The modulation used for the Release 99 was kept for HSDPA Release 5 (QPSK). In addition, a higher modulation (16 QAM) was introduced, optional for the UE for the Release 5.

7.3. Hybrid ARQ

Automatic Retransmission Query (ARQ) is an error detection mechanism used in the link layer. Basically, the receiver informs the transmitter that a block has been received incorrectly and the transmitter resends it. It can be done with a Stop and Wait (SAW) procedure, where the transmitter sends a block and waits for the receiver response before sending a new block or resending the incorrect one. This is not very efficient, since the transmitter is inactive until it gets a response. It can be improved with the dual channel SAW, where two SAW instances work alternatively in the same channel. The solution used for HSDPA is N-channel SAW, which is a generalised version of the dual channel and can be used by multiple users.

Hybrid ARQ is a combination of ARQ and Forward Error Correction (FEC). The erroneous blocks are kept and are used for a combined detection with the retransmissions. There are various types: Code Combining, Incremental Redundancy (IR), Chase combining.

HSDPA will use IR and Chase combining. In the former method, successive retransmissions of an erroneous block are sent with additional redundancy that is increased with each retransmission; with Chase combining, the retransmissions are identical to the original but when combined for detection, they are weighted with their SNR.

The selection of the ARQ methods was based on the memory requirements in the UE and the associated signalling.

8. Intra Domain Connection of RAN Nodes to Multiple CN Nodes (Iuflex)

Acronym: Iuflex
 UID: 2243

References for WI "IU Flex"

Document	Title/Contents
WIDs	
RAN_Work_Items_History	WI Sheet
SP-000619	Intra Domain Connection of RAN Nodes to Multiple CN Nodes
RP-020147	Final Status report
Impacted Specifications	
TS 25.401	UTRAN Overall Description
TS 25.410	Iu General Aspects & Principles
TS 25.413	UTRAN Iu Interface RANAP Signalling
New Dedicated Specifications	
TR 25.875	"NAS Node Selection Function"
TS 23.236	Intra Domain Connection of RAN Nodes to Multiple CN Nodes - Stage 2

This Feature introduces the ability to connect RNCs to more than one MSC and to more than one SGSN. By such, it introduces the ability to provide load sharing between MSCs (or between SGSNs) to improve the efficiency of hardware utilisation further.

In earlier releases, an RNC can only be connected to one MSC and/or one SGSN. This has some drawbacks:

- When an RNC has a relatively large capacity compared to that of the MSC/SGSN, there are frequently significant wastages of hardware;
- Regarding network signalling traffic, with more MSC-server/SGSNs in a network, there are more inter-MSC-server/SGSN registration updates. The signalling associated with these inter-MSC-server/SGSN updates causes additional load on Core Network signalling: MSC-servers, SGSNs, HLRs, and on the radio interface signalling channels.

With this feature and the resulting ability to connect RNCs to more than one MSC and to more than one SGSN, above problems are reduced thanks to load sharing between MSCs (SGSNs). The solution relies on a routing function placed in the RNC. The basic principle is that the MS communicates with the same CN Node even when moving in different RNC areas, as long as the MS keeps moving in the same "Pool Area" (defined below).

This new concept is an architectural option for any PLMN. Its deployment, or non-deployment, by one network operator does not place requirements on other network operators.

Note that this feature does not allow different "core network operators" to share a same radio access network: this is covered by the "Network Sharing" feature in Release 6 and for some specific cases in Release 5 as explained in next section.

The following concepts are introduced:

Pool Area: collection of one or more MSC or SGSN serving areas within which a UE may roam (in both idle and connected modes) without need to change the serving CN node (i.e. MSC-server or SGSN). A Pool Area is served by one or more CN nodes in parallel. Pool areas are configured separately for the CS and PS domains. The following figure shows an example.

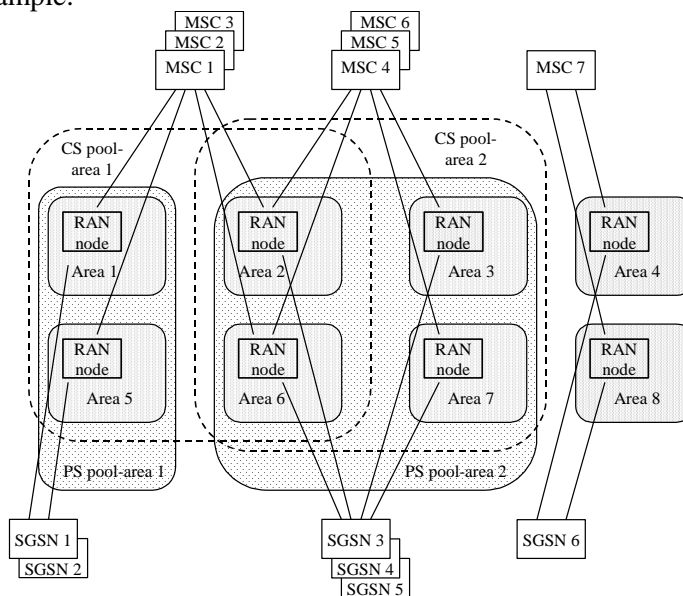

Example of a pool area

NNSF (NAS (Non Access Stratum) Node Selection Function) The NAS Node Selection Function is used in RAN nodes and potentially in CN nodes. In the RAN node the function selects the specific CN node (i.e. MSC or SGSN) to which initial NAS signalling messages are routed. The NRI identifies the specific CN node.

The **Network Resource Identifier (NRI)** uniquely identifies an individual CN node out of all CN nodes which serve in parallel a Pool Area. In areas where Pool Areas overlap, the NRI uniquely identifies a CN node out of all CN nodes which serve all these overlapping Pool Areas, i.e. an NRI uniquely identifies a CN node within a RAN node.

This functionality was also added to GERAN, where BSCs (instead of RNCs) can be connected to several MSCs and/or SGSNs.

In particular, TS 43.051 is impacted by the introduction of support for IDNNS in GERAN Iu mode, TS 48.016 by the use of Gb interface concepts when a network applies IDNNS, and TS 48.018 to include MSC/VLR identity in CS IMSI paging.

9. UTRAN sharing in connected mode

Acronym: NETSHARE

UID: 23004

References for WI "UTRAN sharing in connected mode"	
Document	Title/Contents
WIDs	
RAN_Work_Items_History	WI Sheet
RP-020499	Final Status report
Impacted Specifications	
TS 25.401	UTRAN Overall Description
TS 25.410	UTRAN Iu Interface: General Aspects and Principles
TS 25.413	UTRAN Iu Interface RANAP Signalling
TS 25.423	UTRAN Iur interface RNSAP signalling
New Dedicated Specifications	
TR R3.012	Internal TR on Shared Network Support in Connected Mode

Release 99 and Release 4 specifications include mechanisms in both Core Network and UTRAN to provide a UE specific access restrictions for Location Areas of the current PLMN and other PLMNs when the UE is in Idle Mode. These mechanisms can be used to implement shared network solutions in which, based on roaming agreements, the access restrictions to be applied may be different for different UEs. However, insufficient mechanisms are specified to provide similar access restrictions in Connected Mode. In Connected Mode the UE mobility is handled by UTRAN and it does not have the necessary information, such as roaming agreements, to provide a consistent access restriction handling in Connected Mode.

This Work Item has identified four different solutions to enforce the same access restrictions in Connected Mode as for Release 99 in Idle Mode, of which the solution based on Shared Network Areas (SNAs) has been chosen.

10. IP Multimedia CN Subsystem (IMS)

Global Acronym: IMS

Unique_ID: As listed in the table below

References for WI "IP Multimedia CN Subsystem (IMS)" (main lines of the WP)				
Unique_ID	Name	Acronym	Impacted TS/TR	WID
1273	Provisioning of IP-based multimedia services	IMS		SP-000216
1274	Call control and roaming to support IMS in UMTS	IMS-CCR		SP-010339
1633	Stage 1		22.228	
1514	Stage 2 (Architecture and Main flows)		23.228, 23.002	SP-000289
1296	Impact on MM/CC/SM	IMS-CCR-IWMM		NP-010434
2233	SIP Call Control protocol for the IMS		TS 24.228, TS 24.229, TS 23.218	NP-010643
1998	IMS signalling flows		TS 24.228	
1278	IMS stage 3		TS 24.229	
2255	IMS Session Handling: stage 2		TS 23.218	
1290	Addressing			
2530	Service Examples	IMS-Sex	22.928	
2531	IMS Framework Report	IMS-FrWk	22.941	
1298	Access Security for IMS	IMS-ASEC		SP-010323
33000	SA3 task			
43000	IMS impacts on UICC (ISIM application)			TP-010251
11014	SIP extensions for Integrity protection			
2574	Security Aspects of Requirement for Network Configuration Independence	SEC1-NCI		SP-010324
1299	Lawful interception	IMS-LI		SP-010621
35007	Charging and OAM&P for IMS	IMS-OAM	32-series	SP-010461
2036	Multimedia codecs and protocols for conversational PS services	IMS-CODEC	26.235, 26.236	SP-000398
2039	Codecs		26.235, 26.236	SP-000398

34020	Transport protocols	IMS-CODEC	26.236	
34006	recommendation for QoS parameter values for various media types			
32003	SIP message compression			
32004	Stage 2			
11015	Compression signalling			
10001	Stage 3 description of IMS interfaces			NP-010626
1310	Support of VHE/OSA by entities and protocols of the IMS (e.g. CSCF)	IMS-ONOSA	29.198, 29.998	NP-010692
12000	CAMEL control of IMS services	IMS-CAMEL	23.278, 29.278	NP-020305
31002	Pre-pay/real-time charging in IMS			
35005	Charging	OAM-CH	32.2xy	SP-010631
32006	Charging Implications of IMS architecture			SP-010519
35006	Charging management for IMS (off-line & on-line)	OAM-CH		
1844	Conformance Test Aspects - Provisioning of IMS	IMS-TEST		
41004	Testing of support for IMS - prose		34.108, 34.123	TP-020246
41005	Testing of support for IMS - TTCN		34.108, 34.123	TP-020246

10.1. Introduction

The objective of this feature is to efficiently support applications involving multiple media components as video, audio, and tools like shared online whiteboards, with the possibility to add and drop component(s) during the session. These applications are called IP Multimedia applications (or "services").

The efficient support of these applications is based on the principle that the network is able to dissociate different flows within the multimedia session. These flows are typically used to carry the data resulting from the different media components of the application, and so have different Quality of Service characteristics. As the network knows these characteristics, a more efficiently handling of the resources is possible. It also enables to dissociate the session negotiation from the bearers establishment.

The impact on the network is the creation of a set of new entities dedicated to the handling of the signalling and user traffic flows related to these applications. This set is called the "*IP Multimedia CN subsystem*" (IMS). All IMS entities are located in the Core Network. The impact on non-IMS specific network entities is kept as low as possible.

The fixed Internet multimedia call control "Session Initiated Protocol" (SIP) defined by IETF is chosen as IMS main protocol for its flexible syntax and as to facilitate development and interconnectivity between 3GPP networks and fixed IP networks.

To transport IMS signalling and user data, IMS entities use the bearer services provided by the PS domain and the UTRAN, referred to as the "bearer network"⁹ in the IMS specifications. With some exceptions, the PS domain and the Access Network consider IMS signalling and IMS applications flows as user data flows, hence the minimum impact on non-IMS entities. As part of the bearer services offered by the PS domain to the IMS, the PS domain supports the handover functionality for maintaining the service while the terminal changes the location. IMS can theoretically be used "on top of" other bearer networks than PS domain, but this is not defined in Release 5.

10.2. Main entities and overview of the behaviour

An overview of the IMS architecture is provided below:

⁹ the "bearer network" is also called "access network" in some specifications but this terminology is avoided in this document as leading to confusion with UTRAN

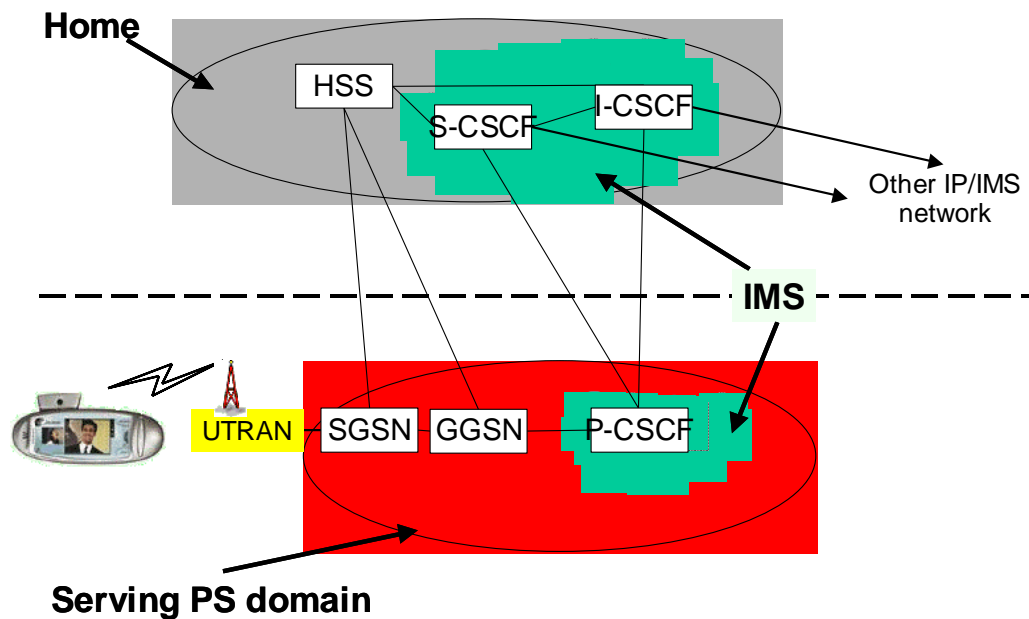

Overview of IMS architecture

The key entities of IMS are:

- Proxy-Call State Control Function (P-CSCF): this is the “first contact point” of IMS. It is located in the same network as the GGSN (visited or home network, shown as being in the visited network in the figure above). Its main task is to select the I-CSCF of the Home Network of the user. It also performs some local analysis (e.g. number translation, QoS policing...).
- Interrogating-CSCF (I-CSCF): this is the “main entrance” of the home network: it selects (with the help of HSS) the appropriate S-CSCF.
- Serving-CSCF (S-CSCF): it performs the actual Session Control: it handles the SIP requests, performs the appropriate actions (e.g. requests the home and visited networks to establish the bearers), and forwards the requests to the S-CSCF /external IP network of other end user as applicable. The S-CSCF might be specialised for the provisioning of a (set of) service(s).
- In addition, the interworking functions and entities, not shown on the figure, are defined for interconnection with legacy networks (PSTN, GSM, GSM+GPRS, UMTS, etc.) as BGCF, IM-MGW... Note that from Release 5 onwards, the name of HLR is changed into "HSS" (Home Subscriber Server) to emphasise that this database contains not only location-related data but also subscription-related data, like the list of services the user is able to get and the associated parameters.

From a dynamic behaviour perspective, the first step is to establish a PS-domain bearer (a PDP context in GPRS) to be used to convey the IMS signalling between the UE and the S-CSCF. After negotiation, other PS-domain bearers are established between the UE and the other end-party to transport the data generated by the IMS application.

10.3. Conversational services and Codec aspects

Within the IMS feature, a work item ensures that default conversational multimedia services can be provided in the PS domain. The WI defines the necessary default codecs and components for a mobile PS conversational multimedia service, for example voice, audio-visual and text conversation.

The definition of default codecs for conversational PS services offers a guaranteed interoperability across terminals and networks. Other advantages are that consistent QoS can be more easily provided, optimum coding will help to minimise the use of the radio resource, and codecs can be implemented efficiently, improving battery life, reducing manufacturing cost, and exploiting overlap with other services.

TS 26.235 contains the set of default codecs for PS conversational multimedia applications within the IMS. Visual and sound communications are specifically addressed. The intended applications are assumed to require low-delay, real-time functionality.

It should be noted that the standardisation of default codecs does not stop the use of other codecs through the network if the end user or end application requires it.

In addition to the specification of default codecs, elements of protocols for bearer control, transport protocols and session protocols are defined for conversational PS multimedia services.

TS 26.236 contains the required protocol usage within 3GPP specified Conversational PS Multimedia Services which is IMS-based. IMS, as a subsystem, includes specifically the conversational IP multimedia services, whose service architecture, call control and media capability control procedures are defined in TS 24.229, and are based on the 3GPP adopted version of SIP.

The individual media types are independently encoded and packetised to appropriate separate Real Time Protocol (RTP) packets. These packets are then transported end-to-end inside UDP datagrams over real-time IP connections that have been negotiated and opened between the terminals during the SIP call as specified in TS 24.229.

The UEs operating within IMS need to provide encoding/decoding of the derived codecs, and perform corresponding packetisation/depacketisation functions. Logical bound between the media streams is handled in the SIP session layer, and inter-media synchronisation in the receiver is handled with the use of RTP time stamps.

10.4. Other aspects

All other system aspects related to the introduction of the IMS are covered in the 3G standard, as:

- Access Security for IMS
- Integrity protection
- Security of SIP signaling between network nodes
- User authentication
- Lawful interception
- SIP Compression
- Charging
- IMS to CS interworking (basic aspects, other ones addressed in later release)
- CAMEL in IMS
- Header compression in UTRAN and GERAN (it will re-use RoHC)

11. Extended Transparent End-to-End Packet Switched Mobile Streaming Applications ("Extended Streaming")

Acronym: PSS-E

UID: 34001

References for WI " Extended Streaming"

Document	Title/Contents
WIDs	
SA4_Work_Item_History	SP-010392
Impacted Specifications	
TS 22.233	Services Requirements for Extended Transparent End-to-End packet Switched Streaming Service (PSS-E)
TS 26.233	PSS Stage 2
TS 26.234	PSS Codec aspects
New Dedicated Specifications	
TS 26.937	RTP usage model

Following on from the Simple Streaming specifications developed under Release 4, more advanced aspects were addressed under Release 5 for Extended Streaming (or PSS-E), as e.g. static content types like timed text (subtitles), and some optional pre-decoder buffering mechanisms. The Release 5 Extended Streaming provides full backwards compatibility with the Release 4 Simple Streaming.

The following multimedia types were added or enhanced:

- Use of SVG-T (Scalable Vector Graphics-Tiny) and PNG (Portable Networks Graphics) for 2D and 3D Graphics
- Use of SP-MIDI (Scalable Polyphony MIDI) for Synthetic Audio
- The scene description was enhanced, still using SMIL 2.0 as for MMS (the use of SMIL "Basic Transition Effect" was added)

The interoperability with the Internet for File Formats and Codecs was improved.

Note that all enhancements to transport aiming at improving robustness and flexibility in the delivery of multimedia content, originally planned to belong to Release 5, were finally shifted to Release 6.

12. OSA improvements

Acronym: OSA2
 UID: 501637

References for WI "OSA improvements"

Document	Title/Contents
WIDs	
SP-000216 (S1-000447)	Scope of Open Interface for Service Provision in Release 5 (SA1)
SP-000302	OSA security (SA3)
NP-010692	Work Item Description OSA Stage 3 Release 5 (CN5)
Impacted Specifications	
22.127	Service Requirement for the Open Services Access (OSA); Stage 1
23.127	Virtual Home Environment (VHE) / Open Service Access (OSA); Stage 2
29.198-01	OSA API; Part 1: Overview
29.198-02	OSA API; Part 2: Common data
29.198-03	OSA API; Part 3: Framework
29.198-04	OSA API; Part 4: Call control
29.198-05	OSA API; Part 5: Generic user interaction
29.198-06	OSA API; Part 6: Mobility
29.198-07	OSA API; Part 7: Terminal capabilities
29.198-08	OSA API; Part 8: Data session control
29.198-11	OSA API; Part 11: Account management
29.198-12	OSA API; Part 12: Charging
29.998-01	OSA API Mapping for OSA; Part 1: General Issues on API Mapping
29.998-04-1	OSA API Mapping for OSA; Part 4: Call Control Service Mapping; Subpart 1: API to CAP Mapping
29.998-05-1	OSA API Mapping for OSA; Part 5: User Interaction Service Mapping; Subpart 1: API to CAP Mapping
29.998-05-4	OSA API Mapping for OSA; Part 5: User Interaction Service Mapping; Subpart 4: API to SMS Mapping
29.998-06	OSA API Mapping for OSA; Part 6: User Location and User Status Service Mapping to MAP
29.998-08	OSA API Mapping for OSA; Part 8: Data Session Control Service Mapping to CAP
New Dedicated Specifications	
29.198-04-1	OSA API; Part 4: Call control; Subpart 1: Common call control data definitions
29.198-04-2	OSA API; Part 4: Call control; Subpart 2: Generic call control data SCF
29.198-04-3	OSA API; Part 4: Call control; Subpart 3: Multi-party call control data SCF
29.198-04-4	OSA API; Part 4: Call control; Subpart 4: Multimedia call control SCF
29.198-13	OSA API; Part 13: Policy management SCF
29.198-14	OSA API; Part 14: Presence and Availability Management (PAM)
29.998-04-4	OSA API Mapping for OSA; Part 4: Call Control Service Mapping; Subpart 4: Multiparty Call Control ISC

Open Service Access (OSA) allows service development by operators and third parties.

OSA enables service application developers to make use of network functionality through open, standardised, secure, extensible and scalable interfaces. Applications see the network functionality offered to them as a set of Service Capability Features (SCFs) in the OSA APIs. These SCFs provide access to the network capabilities on which the application developers can rely when designing their applications. The OSA APIs are independent of where or which network capabilities are implemented in the network, and of vendor-specific solutions and programming languages.

This Release 5 feature enhances the OSA interface for the communication between Applications and Service Capability Features (SCF), based on the following Release 5 network capabilities within the Core Networks:

- *Call Control (IP)*: Takes into account the development of the IP multimedia scenario and addresses the Call Control capabilities based on SIP and/or H.323.
- *E-Commerce*: Takes into account the capabilities provided by the network to use the capabilities provided by the post processing of the charging capabilities (e.g. E-Pay). It also involves the enhancements of the security to be provided by the network work and by the application.
- *User Location*: Further integration of the Location Services within the provisioning of geographical positioning information, taking into account the evolution of the 3G networks associated with this capability.
- *Terminal Capabilities*: A mechanism that is applicable to all types of terminals was introduced (not limited to WAP phones). Security mechanisms for the display of terminal capabilities information were added.

- *Enhanced Session Control*: Enhancements of the bearer manipulation and creation of bearers/sessions (in particular QoS negotiation).
- *Policy Management*
- *Presence and Availability Management*

With respect to the charging aspects, the OSA API offer sufficient charging options to supervise user activities for online charging features, allow applications to access the online account, allow applications to add charging information to network based charging records, and to inform applications on network based charging event.

With respect to the security aspects, the OSA API provide security facilities to guarantee secure access to user confidentially information. Sensitive information has to be prevented from unauthorised access.

This work (stage 1, 2 and 3 specifications) was done jointly with other fora (3GPP2, ETSI SPAN and Parlay), so that there is a single set of standard OSA APIs for the whole development community.

13. CAMEL phase 4

Acronym: CAMEL4
 UID: 1638

References for WI "CAMEL4"

Document	Title/Contents
WIDs	
NP-030486	CAMEL4 scope in Rel-5 for TSG-CN
Impacted Specifications	
TS 22.078	CAMEL - Stage 1
TS 23.078	CAMEL - Stage 2
TS 29.078	CAMEL - Stage 3
New Dedicated Specifications	
TS 23.278	CAMEL/IMS - Stage 2
TS 29.278	CAMEL/IMS - Stage 3

CAMEL feature (Customised Applications for Mobile network Enhanced Logic) is a network feature that provides the mechanisms to support services of operators which are not covered by standardised services, even when roaming outside the HPLMN.

CAMEL phase 4 (or "CAMEL4") contains the functions of CAMEL3 plus the Release 5 additions. CAMEL procedures are usable for CS services and PS services, as appropriate.

A functional entity (VMSC, GMSC or SGSN) may support the complete CAMEL phase 4 functionality or, as a network option, it may support the complete CAMEL phase 3 functionality and a partial implementation of CAMEL phase 4. This capability is called "Handling of partial implementation of CAMEL4" (previously known as "CAMEL4 Functional split into subsets").

CAMEL4 feature supports, in addition to CAMEL3:

- *Support of CAMEL by the IMS* (see also IMS): The capability for the CAMEL Service Environment (CSE) to control sessions in the IMS is added. If the IMS decides to contact the CSE, the IMS shall suspend the handling of the session and wait for instructions from CSE. The CSE may instruct the IMS to bar, continue or redirect the IMS session or to perform other actions like to arm subsequent events, perform charging-related activity, perform user interaction (such as play announcement/tone and prompt and collect digits). Support of CAMEL by the IMS is seen as useful implementation option for IMS pre-paid service in order to use existing pre-paid platforms.
- *Interactions with Optimal Routing*: This enhancement allows the CSE to control the usage of Optimal Routing (OR).
- *CAMEL control over Mobile Terminating Short Message Service (MT SMS)*: This allows CSE control of the MT SMS both in CS and PS. Basically, the VPLMN informs the CSE of a Short Message delivery attempt to the MS and waits for further instruction before continuing processing of the SM. The following CSE control of the MT SMS functionalities are seen particularly useful: CSE monitoring of successful MT SMS for pre-paid, MT SMS charging while roaming, MT SMS charging when primary rate information is received successfully, CSE controlled free format charging data, CSE barring of MT SMS.
- *Provision of location information of called subscriber*: When a terminating call is subject to CAMEL based services, the location of the called subscriber was given at the initial contact from the network to the CSE. For

some services this location information was not sufficient and precise enough. Therefore the functionality of providing the location information of the called party was added to the service logic at the beginning of the call (alerting phase).

- *Inclusion of ODB data in the CSE-HLR interface:* Operator Determined Barring (ODB) data is included for CS and PS in Any Time Modification (ATM) as to make it possible for the CSE (gsm-SCF) to directly instruct the HLR to bar the call or remove the barring online.
- *Inclusion of flexible tone injection.* This introduces enhancements of pre-paid warning tones and various informative tones.
- *Call Party Handling.* This introduces a method of manipulating call legs which includes creating new parties in a call, placing individual call parties on hold, reconnecting them to the group of call parties and disconnecting individual call parties. The purpose of CPH is to support services such as conference call, wake-up calls, parallel hunting and IN based CCBS (Call Completion to Busy Subscriber).
- *Notification of GPRS mobility management to CSE:* this allows the CSE to monitor the location of the mobile subscriber in PS. Mobility Management for GPRS CAMEL Subscription Information (MG-CSI) is downloaded from the HLR to the VPLMN and is used to notify the CSE about Mobility Management events for the GPRS subscriber.
- *Location information during an ongoing call.* The position of a subscriber is the key to a lot of location-based applications. The position of the subscriber was already available when a subscriber is known at the network and when status is idle or when he/she starts a call, but this functionality is introduced to report the location if MS makes a handover during ongoing CS call. For PS calls, CAMEL3 was already enhanced to deliver similar procedures. One of reasons for introduction of this functionality in CAMEL4, from the service continuity point of view, is the provision of services when a subscriber changes from a 2G network to a 3G network and back. To try the best approach offering the same set of services, the fact of “changing location” should be brought to the CSE attention. This functionality enables charging based on current location for inter-PLMN and/or inter system handovers.
- *GPRS Any Time Interrogation.* Any Time Interrogation is enhanced to support GPRS location and state query. The CSE may request the HLR at any time to provide subscriber status information and/or location information.
- *Mid call procedure for MO and MT calls:* Triggering during the Mid-Call Event Detection Point is a capability used for Call Party Handling. The VPLMN notifies the CSE upon detection of the DTMF sequence, and waits for further instruction from the CSE. The CSE service logic defines the DTMF sequences of interest. This allows the CSE to instruct the VPLM to play tones and/or announcements (using local tone generators) to any held party while in the active phase of the call. This also allows prompt-and-collect user interaction with any held party while in the active phase of the call.
- *Transfer of the IMEI (with software version) to the CSE.* The MS classmark and IMEI (including the software version) of the Mobile Equipment (ME) allow the gsmSCF to determine information about the capabilities of the ME, which can be useful to service logic designers. The CSE queries the HLR for the IMEI information via the Any Time Interrogation operation.

14. MExE Enhancements Rel-5

Acronym: MEXE5
Unique_ID: 2464

This feature is structured as if it would have contained several independent items but is finally composed of a single item called "Mobile Execution Environment (MExE) Rel-5 Improvements and Investigations". This is due to historical reasons (in Release 4, there were several items under MExE enhancements). As to avoid purely administrative work, the cleaning up was not made, so the hierarchical structure was kept even if it is not valid anymore.

14.1. MExE Rel-5 Improvements and Investigations

Acronym: MEXE5-ENHANC
Unique_ID: 2466

References for WI "MExE Rel-5 Improvements and Investigations"

Document	Title/Contents
WIDs	
TP-010071	MExE Rel-5 Improvements and Investigations
Impacted Specifications	
TS 22.057	Mobile Execution Environment, stage 1
TS 23.057	Mobile Execution Environment, stage 2
New Dedicated Specifications	
	None

The MExE Release 5 work extends and develops the UE-based support of the client/server model for the flexible support of 3G services (e.g. multimedia services).

The main enhancement is ECMA's¹⁰ "Common Language Infrastructure (CLI)" support as Classmark 4. CLI provides a language-neutral, CPU and OS portable, secure infrastructure for executing applications and services that interoperate seamlessly with highly available web services. The CLI Compact Profile provides a mobile client-focussed subset of these services on a broad market of connected devices. Using multiple programming languages for application and service creation allows adoption of a large pool of programming talent, as well as interoperability between existing service components.

15. Wideband Adaptative Multi Rate Codec

Acronym: WAMR
 Unique_ID: 1625

References for WI "Wideband AMR"

Document	Title/Contents
WIDs	
SA4_Work_Item_History	SP-99354, GP-000453
Impacted Specifications	
TS 26.131	Terminal acoustic characteristics for telephony; Requirements
TS 26.132	Speech and video telephony terminal acoustic test specification
TS 23.972	Circuit switched multimedia telephony
TS 24.008	Mobile radio interface Layer 3 specification; Core network protocols; Stage 3
New Dedicated Specifications	
TS 26.171 to 26.194, 26.201, 26.976	

Existing narrow-band speech codecs achieve good performance for narrow-band speech (audio bandwidth limited to 3.4 kHz). The introduction of a wideband speech service (audio bandwidth extended to 7 kHz) provides improved voice quality especially in terms of increased voice naturalness. Wideband coding brings speech quality exceeding that of (narrowband) wire line quality to 3G and GSM systems.

Design Constraints for the set of 9 Wideband Codec modes for wideband applications fit in 3G/UMTS and Phase 2+ GSM Systems, including EDGE. Three or five AMR wideband codec bit rates, depending on the modulation, GMSK, or 8-PSK, can be used in GERAN (see TS 45.003).

Performance Characterisation in 3G and GSM Radio Access of the WB codec is given in TS 26.976.

Note that this feature does not include WB Conferencing and WB Voice Group calls.

16. Terminal Interfaces

Acronym: TI
 Unique_ID: 1826

This feature contains the item "Terminal Local Model enhancements". Again, some historical reasons explain the odd structure.

¹⁰ European Computer Manufacturer Association

16.1. Terminal Local Model enhancements

Acronym: TLM5

Unique_ID: 2573

References for WI "Terminal Local Model enhancements "

Document	Title/Contents
WIDs	
TP-010224	Terminal local model enhancements
Impacted Specifications	
TS 23.227	Application and User interaction in the UE - Principles and specific requirements
New Dedicated Specifications	
	None

The present rapid development of a diversity of new applications and application environments for mobile usage creates a complexity of previously unseen proportions that the UE has to handle. These applications and application environments co-exist and execute independently in the UE, and thus have the potential to interact with each other in a way that could be detrimental to the positive user experience and sense of user control of the UE. There is a need to control and manage the total applications/interfaces environment and MT resources so as to produce a conceptually consistent and logically whole and integrated user experience.

The work resulting from the feature Terminal Local Model enhancements is the document TS 23.227 which outlines a generic model for the interaction between these applications. It further specifies a set of basic principles and requirements for these applications to co-exist on the UE. The document does not categorise the applications peripherals, but structure the events that are internal and external to, and has to be handled by, the MT Core Functions. This means that the structure or grouping of the events is made from a MT centric perspective. Some applications run on the UE side have counterparts in the network. The document addresses the interactions within the UE.

TS 23.227 was created in Release 4. The enhancement made in Release 5 is the addition of the interaction requirements for USAT bearer independent protocol via local links.

17. (U)SIM toolkit enhancements

Acronym: USAT1/USAT1 Interpr

Unique_ID: 501800, 1801

References for WI "(U)SIM toolkit enhancements"

Document	Title/Contents
WIDs	
TP-000116	Protocol Standardisation of a SIM Toolkit Interpreter
Impacted Specifications	
TS 11.14	Specification of the SIM Application Toolkit for the Subscriber Identity Module - Mobile Equipment, R99
TS 51.014	Specification of the SIM Application Toolkit for the Subscriber Identity Module - Mobile Equipment, R99
TS 31.111	USIM Application Toolkit (USAT)
New Dedicated Specifications	
TS 22.112	USAT Interpreter, stage 1
TS 31.112	USAT interpreter; stage 2; Architecture description
TS 31.113	USAT interpreter; stage 3; Byte Codes
TS 31.114	USAT interpreter; Protocol administration

The objective of the general work item on "(U)SIM toolkit enhancements" is to provide an umbrella work item for the various enhancements carried out on the existing set of SIM and USIM toolkit specifications. For Release 5 such enhancements include the possibility to display toolkit menus in colour and various text formats as well as the extension of the Call Control feature to GPRS.

The work item on "(U)SAT Interpreter protocol" describes the development of new specifications to standardise protocols for (U)SIM resident (U)SIM Toolkit interpreters. The achieved aim was to substitute the existing collection of proprietary specifications which have varying degrees of service delivery and fraud resistance.

The USAT Interpreter makes Mobile Operator services, based on USAT functionality and USIM based security functionality, available to an internet environment. This is achieved by specifying the necessary components and protocols for a secure narrow band channel between the internet application and a USAT Interpreter on the USIM. The actual application could be developed using the application language of choice. Two types of applications interfaces are used as examples, i.e., mark-up language based on WML and Remote Procedure Call (RPC).

The interpreter and the secure narrow band channel form a core platform to enable services like:

- Advanced security functionality, e.g., digital signatures in m-commerce applications
- Value added services based on position and roaming
- Controlled activation and management of other applications.

The secure narrow band channel is achieved by specifying the following:

- specific application and content related functionalities of the interface between the application system and the USAT Gateway;
- specific functionalities and protocols of the interface between the USAT Gateway and the USAT Interpreter associated with a USIM, achieved by defining a low level command set for interpretation by the USAT Interpreter;
- defined level of functionality available to the application server for the implementation of USIM based services such as PKI, location services, push and broadcast services, event based services, etc..

18. Charging and OAM&P

Acronym: OAM
Unique_ID: 501142

References for WI "Charging and OAM&P"

Document	Title/Contents
WIDs	
SP-010461	WID for Charging and OAM&P
SP-010238	WID for BB: Performance Management
SP-010654	WID for BB: Charging Management
Impacted Specifications	
32.101, 32.102	Principles, high level Requirements and Architecture
32.111-1, 32.111-2, 32.111-3, 32.111-4,	Fault Management (FM) FM; Alarm IRP
32.300, 32.301, 32.302, 32.303, 32.304, 32.311, 32.312,	Configuration Management (CM); Name convention for Managed Objects CM Notification IRP Generic IRP management
32.600, 32.601, 32.602, 32.603, 32.604, 32.611, 32.612, 32.613, 32.614, 32.615, 32.621, 32.622, 32.623, 32.624, 32.631, 32.632, 32.633, 32.634, 32.641, 32.642, 32.643, 32.644, 32.651, 32.652, 32.653, 32.654,	Configuration Management (CM); Concept and high-level requirements Basic Configuration Management IRP Bulk CM IRP CM Generic network resources IRP CM Core Network Resources IRP CM UTRAN network resources IRP CM GERAN network resources IRP
32.401, 32.403, 52.402	Performance Management
32.200, 32.205, 32.215, 32.235,	Charging Management
New Dedicated Specifications	
32.321, 32.322, 32.323, 32.324	Test management IRP
32.661, 32.662, 32.663, 32.664	Kernel Configuration Management (CM)
32.671, 32.672, 32.673, 32.674	State Management IRP
32.691, 32.692	Inventory management network resources IRP
32.625, 32.635, 32.645, 32.655	Bulk Configuration Management (CM) XML file format definition
32.225	Charging data description for the IMS (IMS)

The objective of this feature is to continue progressing the Charging and OAM&P framework to be followed by the 3G Telecom Management standardisation and met by all other subsequent specifications - to be produced by all 3GPP TSGs (e.g. SA5, RAN O&M, GERAN O&M, etc. - pertinent to 3G Systems' Telecom Management).

19. GERAN enhancements

Acronym and Unique_ID: See table below

UID	Name	Acronym	Section
2392	GERAN enhancements for streaming services 1 (RLC enhancements)		19.5
2396	GERAN enhancements for streaming services 2 (usage of ECSD)		19.5
2412	GERAN/UTRAN interface evolution 1 (evolution of Iu PS)	GERUEV1	19.1
2416	GERAN/UTRAN interface evolution 2 (evolution of Iu CS)	GERUEV2	19.2
50001	GERAN Inter BSC NACC improvements over the Gb Interface	GERNACC	19.3
50033	Enhanced Power Control	EPC	19.8
50037	8PSK AMR HR	8PSK-AH	19.4
50101	Flow control supporting an MS with multiple data flows with different QoS over the Gb interface	FlowCon	19.11
2345	Alignment of 3G functional split and Iu	GER3GAL	19.9
2330	GERAN support for IMS	GERIMS	19.10

References for the GERAN enhancements

Document	Title/Contents
WIDs	
GP-000481, GP-012752, GP-012748, GP-021256, GP-021263, GP-012313, GP-010420, GP-021767, GP-010429, GP-010430, GP-020492, GP-010431,	Individual WIDs.
Impacted Specifications	
23.060, 29.060, 43.064, 44.060, 48.016, 48.018	See also specific impacted specifications along the text related to individual work items
New Dedicated Specifications	
TS 43.130	Iur-g interface; Stage 2
TS 44.118	Mobile radio interface layer 3 specification, Radio Resource Control (RRC) protocol; Iu mode
TS 44.160	GPRS: Mobile Station (MS) - Base Station System (BSS) interface; Radio Link Control/ Medium Access Control (RLC/MAC) protocol for Iu mode
TS 44.901	External network assisted cell change (NACC)

The different enhancements made on GERAN in Release 5 are listed here. They are not strictly speaking *a* feature but a collection of features.

They are described in the following sub-sections.

19.1. GERAN/UTRAN interface evolution 1: Evolution of Iu PS

GERAN will be connected to the Core Network through different interfaces, at least A, Gb, Iu-cs and Iu-ps. Since Iu-ps is a new interface for GERAN, the requirements from a GERAN perspective on the interface were identified. This work item has identified the requirements and the proposed changes to RAN WG3, which is responsible for updating the specifications related to the Iu-ps interface. The GERAN/UTRAN interface evolution 1 work item provides the requirements on Iu-ps from GERAN perspective and the necessary actions to RAN WG3.

19.2. GERAN/UTRAN interface evolution 2: Evolution of Iu CS

Since the transition to IP multimedia services might not happen immediately, operators may need to support both traditional mobile circuit switched services and IP multimedia services simultaneously. IP multimedia services can only be delivered via the IMS of the PS domain within the GSM-UMTS CN. The ability to offer both CS and PS services via a common GSM-UMTS CN allows low-risk evolution from current networks, while enabling an operator to have full service offering. In order to connect GERAN to the 3G CN, the Iu CS interface has to be

modified slightly in order to cover GERAN specific issues. The ability to map GSM/EDGE radio bearers to the CS domain for optimised voice services and to the PS domain for generic IP multimedia services is greatly desired by some operators.

The soft switch architecture (i.e. MGW/MSC Server) specified within the CS domain of the GSM-UMTS CN provides additional flexibility. Since GSM-UMTS MSC servers are not restricted to a given geographical area, they can be deployed at remote/centralised sites, reducing operations costs and complexity.

This work item mainly keeps the Iu cs in its current state as it is. However, if changes are needed they are kept at a minimum. In order to achieve this, the requirements from GERAN on the current Iu cs have been analysed and the updates to relevant specifications have been done, i.e. 08.08, 08.58, 04.18, 05.05, 05.02, 05.03.

This work item supports the Iu-cs interface connectivity.

A GSM-UMTS CN shall allow:

- Access to CS domain services independently of access to any PS domain service
- Optimised functional reuse between PS and CS domains (e.g. HR 8-PSK channel coding)
- The MS to be attached to both PS and CS domains, and the MS to support multiple simultaneous sessions (e.g. GSM DTM Release 99 feature)
- The support of CS and PS services for both UTRAN and GERAN on the same CN
- Two possible interface options between GERAN and the UMTS CN were considered to support the required functionality: 1) an A interface and/or 2) the Iu-cs interface.

19.3. GERAN Inter BSC NACC improvements over the Gb Interface

This work item improves GPRS cell reselection performance in a GPRS/EGPRS network when cell reselection is performed between cells controlled by different BSCs. TS 23.060 describes the concept.

This work item provides enhanced quality of service regarding reduction of the service outage time at inter BSC cell reselection, reduced packet data loss at the cell-change and reduced need for re-transmission of LLC PDUs transferred during the cell change. Modification of Gb protocols for GERAN Inter BSC NACC over the Gb interface are given in TS 48.018 (Stage 3). Modification of core network protocols for GERAN Inter BSC NACC for Gb interface are given in TS 29.060 (Stage 3).

19.4. 8PSK AMR HR

This work item provides AMR narrow band speech services over 8-PSK modulated half rate channels. By this realisation it will be possible to provide all AMR modes over half rate channels, something which is not possible for GMSK, with the objective to increase the spectrum efficiency by means of 8-PSK modulation. The following specifications were changed: 43.051 Stage 2 description, 44.018 Signalling at channel setup, 45.001 L1 general, 45.002 Channels and channel combinations, 45.003 Channel coding, 45.005 Performance requirements, 51.010 MS test, 51.021 BTS test.

19.5. GERAN enhancements for streaming services 1 & 2

With the 3G alignment in place additional enhancements to increase the performance and spectrum efficiency are obtained for instance by applying limited retransmission or by reusing the ECSD coding.

This work item provides an increase of performance and spectrum efficiency.

19.6. Intra Domain Connection of RAN Nodes to Multiple CN Nodes.

See section 10 of this document.

19.7. Location Services (LCS) for GERAN in A/Gb Mode.

See section 6.3 of this document.

19.8. Enhanced Power Control

The objective of this Work Item is to increase system capacity of GERAN by means of faster power control, by means of changes to 43.051, 44.004, 44.018, 48.058, 45.001, 45.002, 45.003, 45.008.

19.9. Alignment of 3G functional split and Iu

This item provides a platform to provide the four UMTS bearer classes: conversational, streaming, interactive and background. This includes IP end-to-end voice and multimedia services and provides the possibility to connect the 200kHz radio access to a 3G core network. In particular, this work item provides:

- Alignment with UMTS/UTRAN architecture, bearer services and QoS handling
- Spectrum efficiency and performance improvements
- Specification flexibility for future enhancements

The following tasks were completed in GERAN for Release 5:

- Alignment with UMTS bearer concept
- Adoption of the UTRAN PDCP
- Development of RLC / MAC
- Development of GERAN RRC
- Ciphering and integrity protection concept paper
- Multiple TBF concept paper
- Paging concept
- Dedicated physical subchannels (includes traffic and control channels)
- Iu support and broadcast concept
- Impact of using RLC instead of LAPDm concept
- Contention resolution, mobile-station identity, and access concept
- PDCP concept
- Downlink delayed TBF release
- Add transparent RLC Concept
- Handover concept

Physical layer alignment with UMTS bearer concept

- Control channels in 45.003
- Receiver performance in 45.005 for PDTCH/TCH and control channels

Iur-g interface:

Inter BSS interface

- Adoption of relevant parts from Iu r
- Complementation with GERAN specifics
- New stage 3

Inter BSS-RNS interface

- Stage 2
- Adoption of relevant parts from Iu r
- Complementation with GERAN specifics
- New stage 3

Voice over GERAN PS and CS concept

- Architecture for A, Iu cs and Iu ps
- Handover
- RTP payload

19.10. GERAN support for IMS

IP multimedia services should be provided using GERAN via the IMM domain. Specific requirements have been placed in GERAN to enable a spectrum efficient provisioning of optimised speech. This work item provides the

development of header adaptation for GERAN. GERAN Radio access bearer design for IP multimedia, GERAN MS-BSS Conformance test for support of IP multimedia were not standardised.

19.11. Flow control supporting an MS with multiple data flows with different QoS over the Gb interface

Gb interface flow control of data from the SGSN to the BSS per Cell (BVC) or per MS has been part of the standard from Release 97 and onwards. In Release 99, the PFC (Packet Flow Context) procedures to negotiate QoS parameters between the BSS and the SGSN were introduced. This allows several flows with different QoS requirements to be run in parallel for a given MS.

However, the flow control mechanisms have not been improved so far to allow the SGSN work out at any point in time the outstanding data buffered in the BSS for each PFC. This means that the SGSN does not know with which leak rate each PFC is scheduled on the radio interface and therefore the SGSN cannot adapt its scheduling over the Gb interface accordingly.

So this work item provides enhanced quality of service handling as it enables to distinguish High priority QoS flows from low priority flows in both SGSN and BSS.

The main impact is a modification of BSSGP protocol in 48.018.

19.12. Other GERAN aspects

“MS Conformance Testing of Dual Transfer Mode” (UID 54001, Acronym “MSCTDTM”) was considered as a feature although it is a testing activity related to the feature “Dual Transfer Mode” already specified in an earlier release.

20. End-to-End QoS

Acronym: E2EQoS

Unique_ID: 2556 (feature), 2557 to 2559 (BBs)

References for WI "End-to-End QoS"

Document	Title/Contents
WIDs	
SP-010343	WID for feature "End to End QoS for PS Domain including IMS"
NP-010528	WID for BB " E2E QoS interworking"
SP-010461	WID for " QoS Management (Provisioning and Monitoring)"
Impacted Specifications	
TS 29.208, 29.207, 27.060, 29.061, 24.008, 24.228, 24.229, 29.060, 29.163	Stage 3
32-series	OAM aspects
New Dedicated Specifications	
TS 23.207	End-to-end Quality of Service (QoS) concept and architecture

This feature provides the framework for end-to-end Quality of Service and complements the work done in Release 4 mainly in TS 23.107 to describe Quality of Service for the "GPRS Bearer Service". - The specific concepts used in this section are shown in the figure below.- The stage 2 of this feature is given in TS 23.207, which describes the interaction between the TE/MT Local Bearer Service, the GPRS Bearer Service, and the External Bearer Service, and how these together provide Quality of Service for the End-to-End Service, as shown below. It also describes IP level mechanisms necessary in providing end-to-end Quality of Service involving GPRS networks, including possible interaction between the IP level and the GPRS level, as well as the application level and the IP level.

In contrast to TS 23.107, TS 23.207 is only applicable to GPRS packet switched access services (i.e. it does not cover the CS access services), and includes aspects of interworking to the IMS as well as PSTN and other networks.

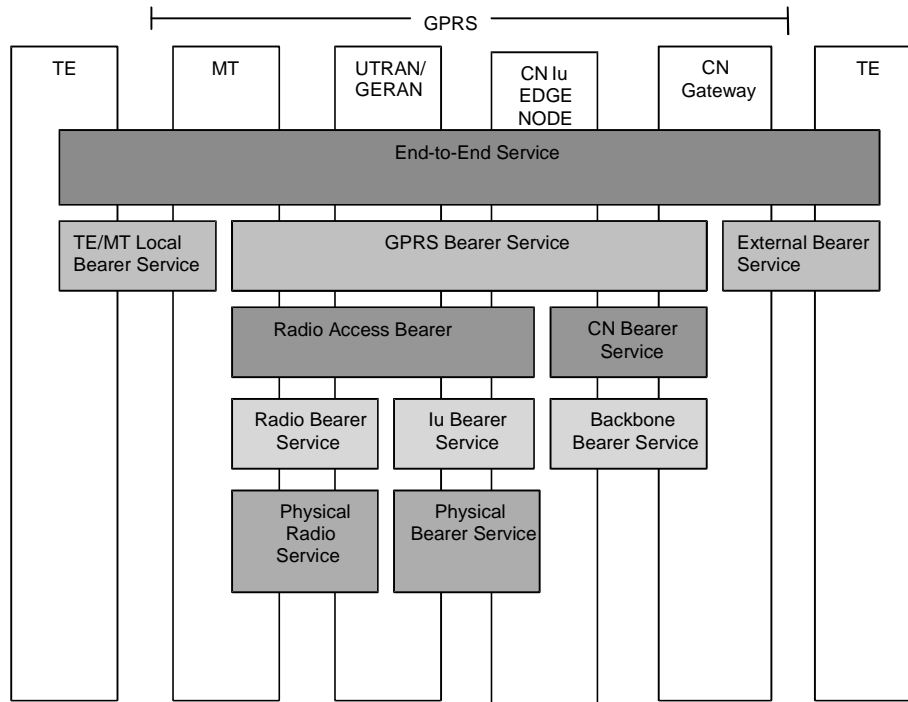

End-to-End QoS Architecture

To provide end-to-end QoS, an "External Bearer Service" has to be established and controlled between the "CN Gateway" (i.e. the GGSN) and the TE, as shown above. This feature addresses the case where this "external bearer service" relies on IP, hence it is also called the "external IP bearer service". For the purpose of controlling it, a function call "IP BS Manager" is implemented in the GGSN and optionally also in the terminal. This function relies on Diffserv Edge Function, IP Policy Enforcement Point and optionally also on RSVP/IntServ.

In the GGSN and in the UE, a translation and mapping function provides the interworking between the mechanisms and parameters used within the GPRS bearer service (also called "UMTS bearer service") and those used within the IP bearer service, and interacts with the IP BS Manager. In the GGSN, the IP QoS parameters are mapped into UMTS QoS parameters as needed.

Another key function for end-to-end QoS is the Policy Decision Function (PDF), which task is to enable the coordination between events in the application layer and resource management in the IP bearer layer: the PDF maps the information obtained from the application level parameters (e.g. SDP) into IP QoS parameters (e.g. RSVP). This mapping is done according to the policy rules. The PDF uses standard IP mechanisms to implement Service Based Local Policy (SBLP) in the IP bearer layer. The PDF's decisions are then communicated to the IP BS Manager in the GGSN, which is the IP Policy Enforcement Point (PEP).

In Release 5, the PDF is a logical entity of the P-CSCF (see chapter on IMS). If the PDF is implemented in a separate physical node, the interface between the PDF and P-CSCF is not standardised.

The interface between the PDF and GGSN is specified within 3GPP and is named the Go interface. The protocol interface between the PDF and GGSN supports the transfer of information and policy decisions between the policy decision point and the IP BS Manager in the GGSN.

A last function related to end-to-end QoS is the so-called "Binding Mechanism", performed by the GGSN, the UE, and the SDP. Its role is to associate the PDP context bearer with one or more IP flows in order to support service-based local policy enforcement. The binding information containing the authorisation token and flow identifier(s) provides the binding mechanism, and is given by the UE to the GGSN in the PDP Context Activation and Modification messages.

21. Messaging Enhancements

Acronym: MESS5

Unique_ID: 2569

The Feature Messaging Enhancements consists of the two independent items: Multimedia Messaging (MMS) enhancements and Enhanced Messaging Service (EMS) enhancements.

21.1. Multimedia Messaging (MMS) enhancements

Acronym: MESS5-MMS
 Unique_ID: 2571

References for WI "MMS enhancements"	
Document	Title/Contents
WIDs	
TP-010130	Multimedia Messaging (MMS) enhancement
Impacted Specifications	
TS 22.140	Multimedia Messaging Service, stage 1
TS 23.140	Multimedia Messaging Service, stage 2/3
TS 26.140	Multimedia Messaging Service, Media Formats and Codecs
New Dedicated Specifications	
	None

After SMS and EMS, the next stage of messaging evolution is MMS, which delivers an even richer messaging experience. MMS allows users to send and receive messages exploiting a large array of the media types available today e.g. text of almost unlimited length, images, audio and video clips, while also making it possible to support new content types as they become popular. MMS supports standard image formats such as GIF (Graphics Interchange Format) and JPEG (Joint Picture Expert Group), video formats such as MPEG 4 (Motion Picture Expert Group) and audio formats and MIDI (Musical Instrument Digital Interface). Multiple media elements can be combined into a composite single message. Messages can be sent either to a mobile phone or to an e-mail address, which offers the customer a wide range of users to communicate with.

After MMS Release 99 and Release 4, further enhancements are introduced with MMS Release 5. The main enhancements are:

- *MM7 (MMS Relay/Server – MMS VAS Applications):* A standardised interface from Value Added Service Provider (VASP) to the MMSC (MMS Center) has been specified. This enables the MMS Relay/Server to support services, in addition to user-to-user messaging, that are either provided by the MMS operator or by third-party VASPs. This also includes support for MM7 charging mechanisms like VASP-related CDR generation, Reverse Charging and Support of Reply-Charging on MM7.
- *Support of persistent storage in MMS:* An optional feature of MMS is the support of persistent, network-based storage, called an “MMBox”, a logical entity associated with the MMS Relay/Server into which Multimedia Messages (MMs) may be stored, retrieved, and deleted. Depending upon an operator’s configuration, each subscriber may have his/her MMBox configured to automatically store incoming and submitted MMs, or, through supporting MMS User Agents, request that specific MMs be persistently stored on a case-by-case basis.
- *Introduction of address resolution mechanisms (based on ENUM or IMSI) and support for Mobile Number Portability:* For those recipients MSISDN addresses that appear in an MM and belong to an external MMSE, the originator MMS Relay/Server translates them to a routable RFC 2822 address that shall be used in the subsequent SMTP commands.
- *Enhanced interworking through Terminal Capability Negotiation:* Within a request for delivery of an MM, the recipient MMS User Agent is able to indicate its capabilities towards the recipient MMS Relay/Server. The detailed definition of the specific mechanism for terminal capability negotiation shall be defined by the MM1 implementation (e.g. WAP).
- *Message Distribution Indicator:* A Content Provider is now enabled to indicate to the recipient via the MMS Relay/Server that the content of an MM or a part of the content of an MM should not be redistributed.

21.2. Enhanced Messaging Service (EMS) enhancements

Acronym: MESS5-EMS
 Unique_ID: 2572

References for WI "EMS enhancements"

Document	Title/Contents
WIDs	
TP-010153	Enhanced Messaging Service (EMS) enhancements
Impacted Specifications	
TS 23.040	Technical Realisation of the Short Message Service
New Dedicated Specifications	
	None

EMS supports a range of formats and data types enabling users to receive rich media content via the SMS transport mechanisms.

The main enhancements in Release 5 are:

- Text Colour, Text Background Colour
- Extended Pictures: maximum of 255 x 255 pixels, black and white, greyscale or colour
- Extended Animations max frame size 255 x 255 pixels, black and white, greyscale or colour
- Extended Sounds, Monophonic and Polyphonic
- Vector based Graphics
- vCard and vCalendar
- Object Distribution Indicator (to limit distribution of objects)
- Compression Control for extended objects
- Hyperlink Information Element
- EMS Delivery Request (new data format in the Extended Object Information Element that allows an SME to request the desired type of data formats)

22. Service Change and UDI Fallback

Acronym: SCUDIF

Unique_ID: 13000

References for WI "SCUDIF"

Document	Title/Contents
WIDs	
NP-020164	WI Sheet
Impacted Specifications	
TS 29.007	General requirements on interworking between the PLMN and the ISDN or PSTN
TS 24.008	Mobile radio interface Layer 3 specification; Core network protocols; Stage 3
TS 27.001	General on Terminal Adaptation Functions (TAF) for Mobile Stations (MS)
TS 26.103	Speech codec list for GSM and UMTS
TS 22.101	Service aspects; Service principles
New Dedicated Specifications	
TS 23.172	Technical realization of CS multimedia service - UDI/RDI fallback and service modification

The SCUDIF service is provided for the establishment of UDI/RDI multimedia calls over the 3GPP network.

UDI/RDI is one part of the Bearer Capability information passed to and from the network: the "information transfer capability" can be set to either UDI ("Unrestricted Digital Information") or RDI ("Restricted Digital Information").

Upon receiving the Bearer Capability information, the network attempts to complete the call using the information contained in the Bearer Capability request. If the request is for a UDI multimedia call, the network will route (or attempt to route) over facilities that have been designated by the operator to supporting UDI. However, if the network does not support UDI, there is either an error or some fallback mechanism is required.

The SCUDIF feature supports the following scenarios:

- Fallback to speech during call setup: allows a user to attempt to set up a multimedia call, and fallback to a speech connection if the former doesn't succeed;

- Fallback to the less preferred service (speech or multimedia) during call setup: allows the terminating side to either accept or reject a multimedia call, without interrupting the call setup;
- Fallback to the preferred service (speech or multimedia) or speech during call setup: allows the call setup to proceed with a single service if the transit network does not support the signalling of this functionality;
- BC negotiation at the terminating side: allows the terminating side to turn a speech call (with service change) into a multimedia call and vice-versa;
- Service change:
 - allows a speech call to be turned to multimedia by either of parties, and back to speech, through a successful in call modification procedure;
 - allows any of the users to reject a multimedia request from the other party while in speech mode.

23. Handling of Early UE

Acronym: LATE_UE

Unique_ID: 32033

References for WI " Handling of Early UE "

Document	Title/Contents
WIDs	
SP-030125	WI Sheet
RAN_SI	Corresponding RAN Study Item
Impacted Specifications	
22.016; 23.002; 23.003; 23.012; 23.016; 23.018; 23.116; 23.009; 29.002; 29.010; 29.018; 29.060; 25.413; 48.008	See WI Sheet for more details on the impacted Specs.
New Dedicated Specifications	
TR 23.895	Report on Provision of UE Specific Behaviour Information to Network Entities
TS 23.195	Provision of UE Specific Behaviour Information to Network Entities
TR 25.994	Measures employed by the UTRAN to overcome early UE implementation faults
TR 25.995	Measures employed by the RAN to cater for legacy UE which conforms to superseded versions of the RAN interface specification

This feature aims at helping the network infrastructure to handle “early User Equipments (UEs)”, which are defined as UEs which were commercially available very early and that are facing problems to support some 3GPP features¹¹ (not fully stable at the time these UEs were deployed). The help is provided by informing the network, and particularly the RAN, on the specific behavior of these UEs. This information is called the “UE Specific Behavior Information (UESBI)”. The associated function is called the Provision of UE Specific Behaviour Information to Network Entities (“PUESBINE”).

UESBI actually corresponds to 2 different sets of information:

- UESBI-Uu which is sent from UE to RAN using signalling specified in the RRC protocol
- UESBI-Iu which is sent by CN to RAN over the Iu interface.

The coding of UESBI-Uu and UESBI-Iu is defined in RRC and RANAP respectively, and have different handling within the network. The SRNC uses both UESBI-Iu and UESBI-Uu to derive the specific behaviour of the UE. The UESBI-Uu information is sent directly or indirectly by the UE, the UESBI-Iu information is retrieved from the IMEISV by the SGSN/MSR.

The UESBI is the basis for correcting mechanisms to overcome some of the issues listed e.g. in TR 25.994, but the description of these correcting mechanisms is out of the scope of this feature.

¹¹ These problems are identified e.g. in TR 25.994 entitled “Measures employed by the UTRAN to overcome early User Equipment (UE) implementation faults”

24. Release Independent Features

24.1. UMTS 1800 and UMTS 1900

Acronym: RInImp-UMTS18, RInImp-UMTS19
 Unique_ID: 1996, 2467 (listed in the Release 4 Work Plan)

References for WIs "UMTS1800/1900"	
Document	Title/Contents
WIDs	
RAN_Work_Items_History	WI Sheet
RP-010815	Final Status report
Impacted Specifications	
TS 25.307 (R99 and up), clauses 4 (UMTS 1800), 5 (UMTS 1900)	Requirements on UEs supporting a Release Independent Frequency Band
TS 25.101	User Equipment (UE) radio transmission and reception (FDD)
TS 25.104	Base Station (BS) radio transmission and reception (FDD)
TS 25.133	Requirements for support of radio resource management (FDD)
TS 25.141	Base Station (BS) conformance testing (FDD)
New Dedicated Specifications	
	None

These two Work Items both follow decisions taken at WARC 00 to extend the existing IMT 2000 frequency allocation to include the bands occupied by 2G cellular bands. The PCS1900 band was part of UTRA FDD since the beginning of the 3GPP project, but its particular requirements and coexistence are not covered in Release 99. The UMTS1900 WI studied co-existence of UTRA FDD and PCS1900, TIA/EIA-136, IS-95 and as a result some RF requirements are modified. Similarly, the UMTS1800 covers the operation of UTRA FDD in the GSM1800 band the the co-existence with these systems.

The support of these bands is release-independent, in the sense that it should be possible to produce a system compliant to *any* Release and using *any* of the bands proposed. The particularities of each combination are listed in 25.307.

For UMTS1800, the deployment scenarios to be supported are:

- One WCDMA carrier in 2x10MHz with geographically coordinated WCDMA and GSM base stations in the same 2x10 MHz band. The WCDMA Uplink and Downlink carriers are surrounded by GSM carriers, noted as a "sandwich" concept (GSM/WCDMA/GSM).
- One WCDMA carrier in a 2x5MHz band with geographically uncoordinated deployment at both band edges.
- Two WCDMA carriers in 2x10MHz band with geographically uncoordinated base station deployments at both band edges.

Three bands are defined for the operation of UTRA FDD:

UTRA FDD frequency bands		
Operating Band	UL Frequencies	DL frequencies
	UE transmit, Node B receive	UE receive, Node B transmit
I	1920 – 1980 MHz	2110 –2170 MHz
II	1850 –1910 MHz	1930 –1990 MHz
III	1710-1785 MHz	1805-1880 MHz

The following FDD radio requirements were modified for the new bands II and III:

- Channel raster
- UE and BS Emission mask
- UE Sensitivity
- UE and BS Narrowband blocking
- UE and BS Narrowband Inter-modulation
- Co-existence requirements.

24.2. Global Text Telephony

Acronym: GTT

Unique_ID: 1517

References for WIs "Global Text Telephony"

Document	Title/Contents
WID	
SP-010340	WI Global Text Telephony
Impacted Specifications	
21.905 , 22.140 , 23.140 , 22.101 , 24.008 , 26.110 , 26.230 , 26.231 , 26.235 , 27.007 , 48.008 , 08.02	See WI Sheet for more details on the impacted Specs.
New Dedicated Specifications	
TS 22.226	Stage 1
TS 23.226	Stage 2
TS 26.226, 26.230	General description and C-code for Specification of Cellular Text telephone Modem
TS 26.231	Minimum Performance requirements for Specification of Cellular Text telephone Modem

Global Text Telephony (GTT) is a feature that adds the capability to use real time, character by character text conversation. One important reason to offer the GTT is to enable emergency service access to people who are depending on a written dialogue.

GTT is defined in a set of protocol environments, both for CS and PS, as e.g. SIP, 3G.324, or Circuit Switched Voice service. CTM (Cellular Text telephone Modem, as specified in TS 26.226), ALI and RTP/text are used as transmission protocols. Existing text presentation format ITU-T T.140, common to all GTT text conversation environments, is used.

The protocol to read and write the characters in UMTS is CTM. Interworking with corresponding features in other networks is an important part of GTT. In the PSTN, text telephony is often based on ITU-T V.18, hence interworking between CTM and ITU-T V.18 is needed and done by introducing conversion in the PLMN or in the AN (different solutions are possible).

25. Features not belonging to Release 5

This sections groups all the items which were once considered as belonging to Release 5 but, because of different reasons, did not lead to any concrete change on the 3GPP Release 5 set of Specifications.

User Equipment Management - Feasibility Study

Not in Release 5.

FS on LCS support in the IMS (this was never done)

Periodic location reports: it was decided that GMLC will be the only entity to handle Periodic location report (and not e.g. MSC, SGSN, UE or RNC as once envisaged).

The following GERAN improvements:

- GERAN improvements "Low chip rate TDD option" and "Gb over IP" are GERAN Release 4 features.
- "Evolution of the transport on the A interface", including "Definition of a new A/Ater Interface Transport Layer option based on the Iu Interface Transport Layer" and "Adaptation of the Layer 3 BSSMAP procedures as required" was finally not standardised, i.e. not producing any impact on the 3GPP specifications.
- GERAN support for IMS

Except for "Development of header adaptation for GERAN" listed above, the following items were not concluded:

- Establishment of requirements for IP multimedia in GERAN especially in regards to optimised speech (terminated, but not completed)
- Optimised design of GERAN radio access bearers for multimedia (terminated. Not standardised)

- Provisioning of physical layer multiplexing to provide means to realise SIP and speech (Terminated. Not standardised)
- GERAN LCS:
 - Provision of Velocity, Privacy Control, and Location of All Mobiles in Geographical Area (LAMGA). This means that an LCS application can request locations and possibly identities of all mobiles in a certain geographical area.
 - The Common LCS Stage 1 mentions Defined Geographical Areas (DEGA). For example, it offers the possibility to identify and report when the user's terminal enters or leaves a specified geographic area. Also certain services might be available to mobiles within specified areas.
- GERAN's Multiple TBF in A/Gb mode, which aimed at producing the necessary changes to the GERAN A/Gb mode standards to support the simultaneous use of multiple Temporary Block Flows (TBFs) by one MS. This was postponed to a later release.
- GERAN improvements 3 (new transport layer on interface A)
- The following PSS-E enhancements:
 - uplink streaming
 - network adaptation
 - adaptation to NW conditions
 - metadata
 - file download
 - DRM (rights management, security)