Source: SA1
Title: Rel-4/Rel-5 to 22.060 with Editorial Corrections
Document for: Approval
Agenda Item: 7.1.3

SA Doc	Spec	CR	Rev	Phase	Cat	Subject	Old Vers	New Vers	SA1 Doc
SP-020240	22.060	024	1	Rel-4	F	Editorial Corrections to TS 22.060 (Rel-4)	4.3.0	4.4.0	
SP-020240	22.060	025	1	Rel-5	A	Editorial Corrections to TS 22.060 (Rel-5)	5.1.0	5.2.0	

CHANGE REQUEST

22.060 CR 024 rev 1 Current version: 4.3.0

For **HELP** on using this form, see bottom of this page or look at the pop-up text over the \approx symbols.

Proposed change affects: \approx (U)SIM ME/UE Radio Access Network Core Network

Title:	\approx Editorial Corrections		
Source:	\approx SA1		
Work item code:	\approx CORRECT	Date:	\approx 11 May 2002
Category:	\approx F	Release:	\approx REL-4
	Use <u>one</u> of the following categories:		Use <u>one</u> of the following releases:
	F (correction)	2	(GSM Phase 2)
	A (corresponds to a correction in an earlier release)	R96	(Release 1996)
	B (addition of feature),	R97	(Release 1997)
	C (functional modification of feature)	R98	(Release 1998)
	D (editorial modification)	R99	(Release 1999)
	Detailed explanations of the above categories can be found in 3GPP TR 21.900 .		REL-4 (Release 4)
		REL-5 (Release 5)	

Reason for change:	\approx UTRAN and GERAN terminology inconsistent with other Stage 1s. Unused references.
Summary of change:	\approx Correction of GERAN and UTRAN Terminology and removal of unnecessary text.
Consequences if not approved:	\approx Stage 1 will not accurately reflect GPRS Service Requirements

Clauses affected:	\approx Various.	
Other specs affected:	<input type="checkbox"/> Other core specifications \approx <input type="checkbox"/> Test specifications <input type="checkbox"/> O&M Specifications	
Other comments:	\approx 	

How to create CRs using this form:

Comprehensive information and tips about how to create CRs can be found at <http://www.3gpp.org/specs/CR.htm>. Below is a brief summary:

- 1) Fill out the above form. The symbols above marked \approx contain pop-up help information about the field that they are closest to.
- 2) Obtain the latest version for the release of the specification to which the change is proposed. Use the MS Word "revision marks" feature (also known as "track changes") when making the changes. All 3GPP specifications can be downloaded from the 3GPP server under <ftp://ftp.3gpp.org/specs/>. For the latest version, look for the directory name with the latest date e.g. 2001-03 contains the specifications resulting from the March 2001 TSG meetings.
- 3) With "track changes" disabled, paste the entire CR form (use CTRL-A to select it) into the specification just in front of the clause containing the first piece of changed text. Delete those parts of the specification which are not relevant to the change request.

2 References

The following documents contain provisions which, through reference in this text, constitute provisions of the present document.

?? References are either specific (identified by date of publication, edition number, version number, etc.) or non-specific.

?? For a specific reference, subsequent revisions do not apply.

?? For a non-specific reference, the latest version applies. In the case of a reference to a 3GPP document (including a GSM document), a non-specific reference implicitly refers to the latest version of that document *in the same Release as the present document*.

- [1] 3GPP TS 22.001: " Principles of telecommunication services supported by a Public Land Mobile Network (PLMN)".
- [2] 3GPP TS 24.002: " Public Land Mobile Network (PLMN) access reference configuration".
- [3] ISO 8348: "Information processing systems - data communications - network service definition".
- [4] Internet STD 5:RFC 791: Internet protocol, RFC 950: "Internet standard subnetting procedure", RFC 919: "Broadcasting internet datagrams", RFC 922: "Broadcasting internet datagrams in the presence of subnets", RFC 792: "Internet control message protocol", RFC 1112: "Host extensions for IP multicasting" RFC 1122:" Requirements for Internet hosts - communication layers". RFC 1920:" Internet official protocol standards", RFC 1458: "Requirements for multicast protocols", RFC 1301: "Multicast transport protocol".
- [5] 3GPP TS 22.004 (~~ETS 300 918~~): " General on supplementary services".
- [6] 3GPP TS 22.030 (~~ETS 300 907~~): " Man-Machine Interface (MMI) of ~~the Mobile Station (MS)~~theUser Equipment (UE)".
- [7] 3GPP TS 42.017 : "Subscriber Identity Modules (SIM) Functional characteristics".
- [8] 3GPP TS 22.041: "Operator Determined Barring (ODB)"
- [9] 3GPP TS 27.060: "General Packet Radio Service (GPRS); Mobile Station (MS) supporting GPRS".
- [10] ~~3GPP TR 21.905: "Vocabulary for 3GPP Specifications"~~3GPP TS 43.055: " Dual Transfer Mode: stage 2".

3 Definitions and abbreviations

3.1 Definitions

For the purposes of this3GPP TS the following definitions apply:

A

access delay: The value of elapsed time between an access request and a successful access (source: ITU-T X.140).

~~**access protocol:** a defined set of procedures that is adopted at an interface at a specified reference point between a user and a network to enable the user to employ the services and/or facilities of that network (source: ITU-T I.112).~~

accuracy: A performance criterion that describes the degree of correctness with which a function is performed. (The function may or may not be performed with the desired speed.) (source: ITU-T I.350).

B

bearer service: A type of telecommunication service that provides the capability for the transmission of signals between user-network interfaces (source: ~~3GPP TR 21.905 [10]~~, ITU-T I.112).

~~**broadcast:** A value of the service attribute "communication configuration", which denotes unidirectional distribution to all users (source: ITU-T I.113).~~

C

~~**closed group:** A group with a pre-defined set of members. Only defined members may participate in a closed group.~~

conversational service: An interactive service which provides for bi-directional communication by means of real-time (no store-and-forward) end-to-end information transfer from user to user (source: ITU-T I.113).

D

~~**dependability:** A performance criterion that describes the degree of certainty (or surety) with which a function is performed regardless of speed or accuracy, but within a given observational interval (source: ITU-T I.350).~~

destination user: Entity to which calls to the General Packet Radio Service (GPRS) are directed.

F

~~**functional group:** A set of functions that may be performed by a single equipment (source: ITU-T I.112).~~

G

I

interactive service: A service which provides the means for bi-directional exchange of information between users. Interactive services are divided into three classes of services: conversational services, messaging services and retrieval services (source: ITU-T I.113).

interface: The common boundary between two associated systems (source: ~~3GPP TR 21.905 [10]~~, ITU-T I.112).

M

mean bit rate: A measure of throughput. The average (mean) bit rate available to the user for the given period of time (source: ITU-T I.210).

messaging service: An interactive service which offers user-to-user communication between individual users via storage units with store-and-forward, mailbox and/or message handling, (e.g., information editing, processing and conversion) functions (source: ITU-T I.113).

~~**mobile station:** Equipment intended to access a set of PLMN telecommunication services. Services may be accessed while the equipment capable of surface movement within the system area is in motion or during halts at unspecified points.~~

mobile termination: The part of the ~~mobile station~~ UE which terminates the radio transmission to and from the network and adapts terminal equipment capabilities to those of the radio transmission (source ~~3GPP TR 21.905 [10]~~).

multicast service: A unidirectional PTM service in which a message is transmitted from a single source entity to multiple destinations.

multipoint: A value of the service attribute "communication configuration", which denotes that the communication involves more than two network terminations (source: ITU-T I.113).

N

network operator: Entity which provides the network operating elements and resources for the execution of the General Packet Radio Service (GPRS).

network service data unit (NSDU): A unit of data passed between the user and the GPRS network across a Network Service Access Point (NSAP).

network termination: A functional group on the network side of a user-network interface (source: ITU-T I.112).

O

~~**open group:** A group that does not have a pre-defined set of members. Any user may participate in an open group.~~

P

packet: An information unit identified by a label at layer 3 of the OSI reference model (source: ITU-T I.113). A network protocol data unit (NPDU).

packet data protocol (PDP): Any protocol which transmits data as discrete units known as packets, e.g., IP.

packet transfer mode: Also known as packet mode. A transfer mode in which the transmission and switching functions are achieved by packet oriented techniques, so as to dynamically share network transmission and switching resources between a multiplicity of connections (source: ITU-T I.113).

PLMN Operator: Public Land Mobile Network operator. The entity which offers a GPRS.

point-to-multipoint (PTM) service: A service type in which data is sent to "all service subscribers or a pre-defined subset of all subscribers" within an area defined by the Service Requester.

point-to-point (PTP): A value of the service attribute "communication configuration", which denotes that the communication involves only two network terminations.

point-to-point (PTP) service: A service type in which data is sent from a single network termination to another network termination.

protocol: A formal set of procedures that are adopted to ensure communication between two or more functions within the within the same layer of a hierarchy of functions (source: ITU-T I.112).

protocol data unit (PDU): In the reference model for OSI, a unit of data specified in an (N)-protocol layer and consisting of (N)-protocol control information and possibly (N)-user data (source: ITU-T X.200 / ISO-IEC 7498-1).

push service: service type which delivers information (data/multimedia) initiated from a network (which may be external to the PLMN) to the UE. The service will cause a PDP context to be activated if needed.

Q

quality of service: The collective effect of service performances which determine the degree of satisfaction of a user of the service (ITU-T E.800). The set of performance parameters that can be directly observed and measured at the point at which the service is accessed by the user. There are three criteria by which performance is measured: speed, accuracy and dependability (source: ITU-T I.350).

R

reference configuration: A combination of functional groups and reference points that shows possible network arrangements (source: ~~3GPP TR 21.905 [10]~~, ITU-T I.112).

reference point: A conceptual point at the conjunction of two non-overlapping functional groups (source: ~~3GPP TR 21.905 [10]~~, ITU-T I.112).

retrieval service: An interactive service which provides the capability of accessing information stored in data base centres. The information will be sent to the user on demand only. The information is retrieved on an individual basis, i.e., the time at which an information sequence is to start is under the control of the user (source ITU-T I.113).

S

SDU loss probability: The ratio of total lost service data units (SDUs) to total transmitted service data units in a specified sample (source: ITU-T X.140).

~~NOTE: the source document term "user information unit" has been replaced by the term "service data unit".~~

~~NOTE: the source document term "user information unit" has been replaced by the term "service data unit".~~

SDU transfer delay: The value of elapsed time between the start of transfer and successful transfer of a specified service data unit (SDU) (source: ITU-T X.140).

~~NOTE: the source document term "user information unit" has been replaced by the term "service data unit".~~

SDU transfer rate: The total number of successfully transferred service data units (SDUs) in a transfer sample divided by the input/output time for that sample. The input/output time is the larger of the input time or the output time for the sample (source: ITU-T X.140).

~~NOTE: the source document term "user information unit" has been replaced by the term "service data unit".~~

service access point (SAP): In the reference model for OSI, the points through which services are offered to an adjacent higher layer (source: 3GPP TR 21.905 [10], ITU-T X.200 / ISO-IEC 7498-1).

service attribute: A specified characteristic of a telecommunication service (source: ITU-T I.112).

NOTE: the value(s) assigned to one or more service attributes may be used to distinguish that telecommunications service from others.

~~**service bit rate:** The bit rate that is available to a user for the transfer of user information (source: ITU-T I.113).~~

~~**service category or service class:** A service offered to the users described by a set of performance parameters and their specified values, limits or ranges. The set of parameters provides a comprehensive description of the service capability.~~

service data unit (SDU): In the reference model for OSI, an amount of information whose identity is preserved when transferred between peer (N+1)-layer entities and which is not interpreted by the supporting (N)-layer entities (source: ITU-T X.200 / ISO-IEC 7498-1).

service delay: The time elapsed from the invocation of the service request, to the corresponding service request indication at the Service Receiver, indicating the arrival of application data.

~~**service model:** A general characterisation of services based upon a QoS paradigm, without specifying the actual performance targets.~~

service provider: Entity which offers the General Packet Radio Service (GPRS) for subscription. The network operator may be the service provider.

service receiver: The entity which receives the service request indication primitive, containing the SDU.

service request: This is defined as being one invocation of the service through a service request primitive.

service requester: The entity which requests the initiation of a GPRS operation, through a service request.

service subscriber: Entity which subscribes to the General Packet Radio Service (GPRS) service.

~~**signalling:** The exchange of information specifically concerned with the establishment and control of connections, and with management, in a telecommunications network (source: ITU-T I.112).~~

speed: A performance criterion that describes the time interval required to perform a function or the rate at which the function is performed. (The function may or may not be performed with the desired accuracy.) (source: ITU-T I.350).

~~**supplementary service:** A service that modifies or supplements a basic telecommunication service (as defined in 3GPP TR 21.905 [10]). It cannot be offered to a customer as a stand-alone service. It must be offered together or in association with a basic telecommunication service (bearer or teleservice). The same supplementary service may be common to a number of telecommunication services (source: ITU-T I.210).~~

T

telecommunication service: That which is offered by a PLMN operator or service provider to its customers in order to satisfy a specific telecommunication requirement. (source: 3GPP TR 21.905 [10], ITU-T I.112). Telecommunication services are divided into two broad families: bearer services and teleservices (source: ITU-T I.210).

teleservice: A type of telecommunication service that provides the complete capability, including terminal equipment functions, for communication between users according to protocols established by agreement between Administrations (source: 3GPP TR 21.905 [10], ITU-T I.112).

terminal equipment: Equipment that provides the functions necessary for the operation of the access protocols by the user (source: 3GPP TR 21.905 [10]). A functional group on the user side of a user-network interface (source: ITU-T I.112).

throughput: A parameter describing service speed. The number of data bits successfully transferred in one direction between specified reference points per unit time (source: ITU-T I.113).

transit delay: A parameter describing service speed. The time difference between the instant at which the first bit of a protocol data unit (PDU) crosses one designated boundary (reference point), and the instant at which the last bit of the PDU crosses a second designated boundary (source: ITU-T I.113).

U

user access or user network access: The means by which a user is connected to a telecommunication network in order to use the services and/or facilities of that network (source: 3GPP TR 21.905 [10], ITU-T I.112).

user network interface: The interface between the terminal equipment and a network termination at which interface the access protocols apply (source: ITU-T I.112).

user-user protocol: A protocol that is adopted between two or more users in order to ensure communication between them (source: ITU-T I.112).

V

variable bit rate service: A type of telecommunication service characterised by a service bit rate specified by statistically expressed parameters which allow the bit rate to vary within defined limits (source: ITU-T I.113).

3.2 Abbreviations

For the purposes of this 3GPP TS the following definitions apply:

CLNP	Connectionless network protocol
CLNS	Connectionless network service
EGPRS	Enhanced GPRS
FFS	For further study
GPRS	General packet radio service
HSDPA	High Speed Downlink Packet Access
IP	Internet protocol
IP-M	Internet protocol multicast
NSDU	Network service data unit
PDP	Packet data protocol
PDU	Protocol data unit
PLMN	Public land mobile network
PTM	Point to multipoint
PTP	Point to point
QoS	Quality of service
SAP	Service access point
SVC	Switched virtual circuit
SDU	Service data unit
TBD	To be defined

TLLI Temporary link level identity

4 Main Concepts

The GPRS allows the service subscriber to send and receive data in an end-to-end packet transfer mode, without utilizing network resources in circuit switched mode.

GPRS enables the cost effective and efficient use of network resources for packet mode data applications e.g. for applications that exhibit one or more of the following characteristics:

- intermittent, non-periodic (i.e., bursty) data transmissions, where the time between successive transmissions greatly exceeds the average transfer delay;
- frequent transmissions of small volumes of data, for example transactions consisting of less than 500 octets of data occurring at a rate of up to several transactions per minute;
- infrequent transmission of larger volumes of data, for example transactions consisting of several kilobytes of data occurring at a rate of up to several transactions per hour.

Within the GPRS, two different bearer service types are defined. These are:

- Point-To-Point (PTP);
- Point-To-Multipoint (PTM).

Based on standardized network protocols supported by the GPRS bearer services, a GPRS network administration may offer (or support) a set of additional services. This is outside the scope of this specification, however, a number of possible PTP interactive teleservices include:

- retrieval services which provide the capability of accessing information stored in data base centres. The information is sent to the user on demand only. An example of one such service in the Internet's World Wide Web (WWW);
- messaging services which offer user-to-user communication between individual users via storage units with store-and-forward mailbox, and/or message handling (e.g., information editing, processing and conversion) functions;
- conversational services which provide bi-directional communication by means of real-time (no store-and-forward) end-to-end information transfer from user to user. An example of such a service is the Internet's Telnet application;
- tele-action services which are characterized by low data-volume (short) transactions, for example credit card validations, lottery transactions, utility meter readings and electronic monitoring and surveillance systems.

Some examples of teleservices which may be supported by a PTM bearer service include:

- distribution services which are characterized by the unidirectional flow of information from a given point in the network to other (multiple) locations. Examples may include news, weather and traffic reports, as well as product or service advertisements;
- dispatching services which are characterized by the bi-directional flow of information from a given point in the network (dispatcher) and other (multiple) users. Examples include taxi and public utility fleet services;
- conferencing services which provide multi-directional communication by means of real-time (no store-and-forward) information transfer between multiple users.

EGPRS is an enhancement of GPRS for GERAN allowing higher data rates on the radio interface. The same set of services provided by GPRS is available in EGPRS.

HSDPA is an enhancement to Packet data services for UTRAN allowing higher data rates on the radio interface downlink. The same set of services provided by GPRS is available with GPRS using HSDPA.

5 Service Requirements

5.1 GPRS reference model

The GPRS can be described using the simplified reference model in figure 1.

GPRS provides data transfer capabilities between a sending entity and one or more receiving entities. These entities may be an UE or a Terminal Equipment, the latter being attached either to a GPRS network or to an external data network. The base station provides radio channel access for UEs to the GPRS network. User data may be transferred between four types of UEs as described in 3GPP TS 22.001 [1] and 3GPP TS 24.002 [2].

Each PLMN has two access points, the radio interface (labelled Um for GERAN and Uu for UTRAN) used for mobile access and the R reference point used for origination or reception of messages. The R reference point for the UEs is defined in 27.060 [9].

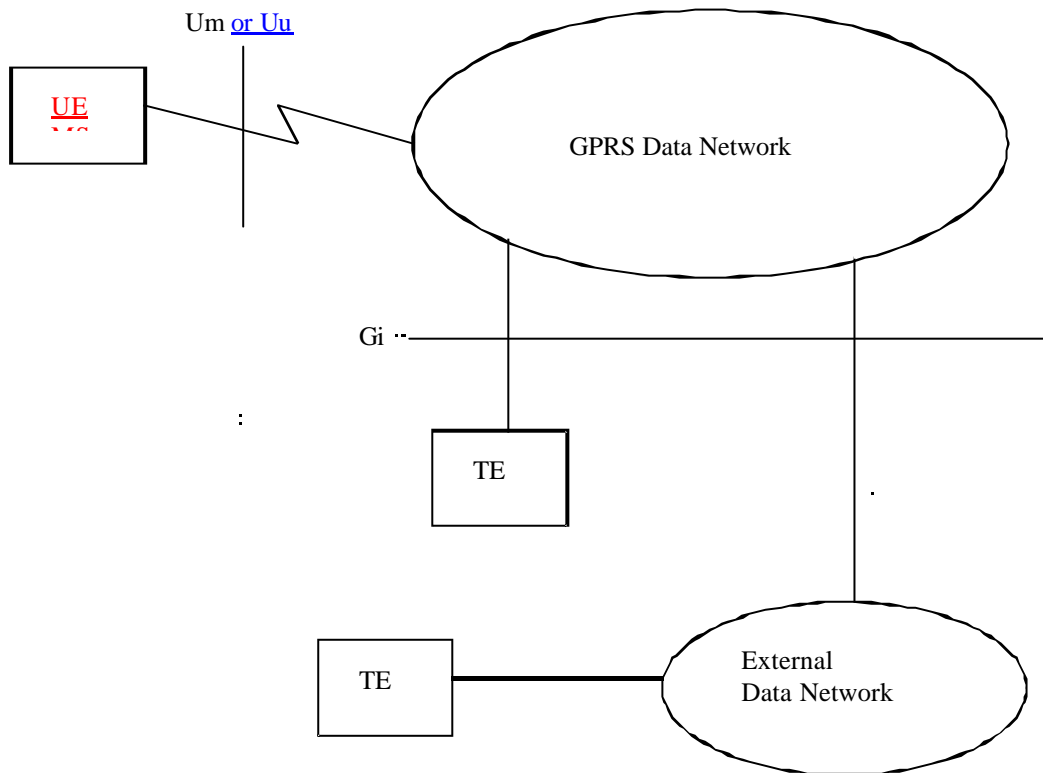

Figure 1: GPRS simplified reference model

5.1.1 Bearer services

The GPRS bearer services support the capability to transmit data between user-network access points.

5.1.2 (Void)

5.1.3 (Void)

5.2 Network Interworking

Network interworking is required whenever a PLMN and a non-PLMN are involved in the execution of a GPRS Service request.

In general the mobile user of a GPRS network will receive and experience all the services provided by an external data network. In this case the external data network refers to the network that the GPRS PLMN interworks with as determined by the network operator. With this in mind it can be said that a user :-

- 1) will require a universal identity(ies) of the form compatible with the interworked with network(s);
- 2) and experience access to and provision of all services as offered by the interworked with networks (some reduction of capability may result from unavoidable restrictions due to the complexity of implementation).

5.2.1 Interworking with other data networks and other PLMNs

GPRS shall provide means to interwork with external data networks. The GPRS operator may provide an appropriate address to the external data network for the subscriber as part of the GPRS subscription. That address can be either dynamic (e.g. the user's IP address is allocated from a pool of unused IP addresses every time the subscriber activates the access to an IP network) or static (e.g. a certain IP address is permanently allocated to a particular subscriber). In addition, the GPRS network shall be able to notify the server IP address (e.g. the gateway IP address) to the subscriber, when the subscriber activates. When connected with some external data networks, the routing protocols of these networks may limit the data network addresses that can be allocated. For example, when interworking with IP networks, the IP address for the GPRS subscriber shall belong to that GPRS operator's IP subnetwork that allocates the address. In the case of a simple point to point connection, a GPRS subscriber need not have an associated network address.

The type of interworking between a PLMN and data networks is determined by the network operator.

Interworking with the following types of data networks shall be defined:

- IP networks;
- other PLMNs, directly or via a transit network.

5.2.1.1 QoS when Interworking

GPRS shall satisfy, within the constraints introduced by the mobile radio environment, the QoS requirements of the interworked-with network.

5.2.2 GPRS Numbering Plan

It is required that GPRS UE addresses conform to the numbering plan already defined for 3GPP system.

5.2.3 Addressing and routing requirements

5.2.3.1 PTP network layer services

A GPRS subscriber identified by an IMSI, may have a network layer address(es) temporarily and/or permanently associated with it that conforms to the standard addressing scheme of the respective network layer service used, e.g.:

- IP Version 4 and 6 addresses for Internet CLNS.

In the case of a simple point to point connection, a GPRS subscriber need not have an associated network layer address.

5.2.4 Interworking for subscriber roaming

Interworking between different GPRS PLMNs is required in order to support subscriber roaming.

It shall be possible for the VPLMN to provide access to the external data network when the external non-3GPP data network address is dynamically assigned by the VPLMN.

5.3 GPRS service description

There are two categories of GPRS services:

- Point to Point (PTP) services,
- Point to Multipoint (PTM) services.

The PTP service provides a transmission of one or more packets between two users, initiated by a service requester and received by a receiver.

There is one PTP service: - PTP Connectionless Network Service (PTP-CLNS). The PTM service provides a transmission of packets between a service requester and a receiver group.

There is one PTM service:

- IP Multicast (IP-M).

An invocation of the service request by a service requester is possible from the fixed and mobile access points.

Table 1 presents the relationship between service requests and the Service Requester/Receiver.

Table 1: Relationship of service request and service requester/receiver

Service requester/receiver AP = Access Point	Types of service request	
	PTP-CLNS	IP-M
From fixed AP to mobile AP	Supported	Supported
From mobile AP to mobile AP (see note 1)	Supported	Supported
From mobile AP to fixed AP	Supported	Supported

NOTE 1: It shall be possible to transfer data between two mobiles of the same operator without the use of external data networks.

5.3.1 Point-To-Point Connectionless Network Service (PTP-CLNS)

Point-To-Point Connectionless Network Service (PTP-CLNS) is a service in which one (or more) single packet(s) is (are) sent from a single service subscriber "A" to a single destination user "B". Each packet is independent of the preceding and succeeding packet. This service is of the datagram type and is intended to support bursty applications. On the radio interface PTP-CLNS supports the acknowledged transfer mode for reliable delivery.

GPRS provides data communications services consistent with the connectionless network layer service definition ISO 8348 [3]. Specifically, GPRS shall be able to support applications based on the following network layer protocol:

- Internet Protocol (IP);
- IP is the network layer protocol of the Internet TCP/IP protocol suite defined by Internet STD 5 [4].

5.3.2 (Void)

5.3.3 Point-To-Multipoint (PTM) service overview

A PTM service is the transmission of a single message to multiple subscribers. The GPRS PTM services provide the capability for a subscriber to send data to multiple destinations.

There is one PTM service:

- IP Multicast (IP-M), which is a service defined as a part of the IP protocol suite. In IP-M messages are sent between participants of an IP-M group. An IP-M group can be internal to the PLMN or distributed across the Internet. Participation and data transfer in the IP-M service shall be compliant with the Internet protocols. See RFC 1920 [4], RFC 1458 [4], RFC 1301 [4] and RFC 1112 [4]. The Service Receiver of a point-to-multipoint service request shall be able to filter out packets at a network level, through use of the Packet Identities, which are of no interest either because they are for a service for which no subscription is held, or the packet belongs to a sub-group within the offered application service which is of no interest. It is required that the UE-Application resources shall not be utilized for this function.

Table 2: PTM Service Characteristics

Characteristics	IP-M
Primary addressing mechanism	specified group of subscribers
Secondary addressing mechanism	no
Present subscribers known	yes, group members shall join the IP-M call to become participants.
Delivery time	real time
Direction of transmission	multi-directional
Reliable delivery	acknowledged as normal IP PTP packets
Ciphering	yes

5.4 Service interworking

It shall be possible for the GPRS PTP services to be utilized as a bearer service for the SMS-MO and SMS-MT services.

5.5 Transfer Characteristics

The packet multiplexing mechanisms developed for GPRS shall be independent of a given channel type. It shall be possible to operate GPRS over low and high capacity channels. Table 3 is only applicable to the GPRS part of the connection.

Table 3: Transfer Characteristics

Attributes		Supported capabilities
Information Transfer Capability		Unrestricted digital information
Information Transfer Mode	Connection mode	Connection orientated, connectionless
	Traffic type ^(a)	Variable bit rate and variable delay
	Timing end-to-end ^(b)	Asynchronous
Information Transfer Rate ^(c)		Maximum bit rate.
Information Structure		- Service data unit integrity - Data sequence integrity
Communication Configuration		- Point to point - Point to multipoint
Establishment of Communication ^(d)		Demand mobile originated or mobile terminated
Negotiation		- Out of band - In band
Symmetry		- Bi-directional - Unidirectional
Radio Channel assignment		Shared, multi-user

- a) Traffic type: describing data streams with constant bit rate or variable bit rate characteristics.
- b) Timing end-to-end: describing the timing relation between the source and destination of signals.
- c) Flexible channels with a maximum bit rate that depends on the type of channel and the number of time slots [in GERAN](#) that are used. This capability defines the maximum capability associated with the channel(s). The actual bit rate for a particular user may be any value up to this maximum value.
- d) Establishment of communication: may be on demand, reserved or permanent.

5.6 Service characteristics

5.6.1 Subscriber profile

The subscriber profile holds subscription information about services and other parameters that have been assigned for an agreed contractual period. It includes the following information:

- subscribed services (PTP-CLNS);
- subscribed QoS profile (service precedence(priority), reliability, delay, throughput).

An invocation of a service by any user with the appropriate subscription profile shall be possible.

It shall be possible to validate a service request against a service subscriber's subscription profile.

5.6.2 Quality of Service (QoS)

The mapping of user application QoS parameters to GPRS QoS parameters is an implementation issue and is not part of GPRS specifications.

It shall be possible to respond to local data traffic conditions adaptively. GPRS shall include the functionality to increase or decrease the amount of radio resources allocated to GPRS on a dynamic basis. The criteria used to decide on dynamic changes of the GPRS part of the radio resource should not be specified. Thus, only the necessary procedure, including radio protocol and timers, needed to perform the change of radio resources shall be specified within the ETSI specifications.

Within GPRS the dynamic allocation of the radio resource for bursty or lengthy file transfer applications shall be such that it can be controlled by the network operator.

5.6.2.1 QoS parameter definitions

The defined QoS parameter values, assume the user is at a location with acceptable -coverage and refer to and are valid for normal network operating conditions or, as in the case of the service precedence parameter, regulate how the network shall handle abnormal conditions.

5.6.2.1.1 Service precedence (priority)

The service precedence indicates the relative priority of maintaining the service. For example under abnormal conditions (e.g. network congestion) packets which may be discarded can be identified. The following precedence levels are defined:

- High precedence: Service commitments will be maintained ahead of all other precedence levels.
- Normal precedence: Service commitments will be maintained ahead of low priority users.
- Low precedence: Service commitments will be maintained after the high and normal priority commitments have been fulfilled.

5.6.2.1.2 Reliability

The reliability parameter indicates the transmission characteristics that are required by an application. The reliability class defines the probability of loss of, duplication of, mis -sequencing of or corruption of SDUs.

Table 4 lists the three classes of the data reliability.

Table 4: Reliability classes

Reliability class	Lost SDU probability (a)	Duplicate SDU probability	Out of Sequence SDU probability	Corrupt SDU probability (b)	Example of application characteristics.
1	10^{-9}	10^{-9}	10^{-9}	10^{-9}	Error sensitive, no error correction capability, limited error tolerance capability.
2	10^{-4}	10^{-5}	10^{-5}	10^{-6}	Error sensitive, limited error correction capability, good error tolerance capability.
3	10^{-2}	10^{-5}	10^{-5}	10^{-2}	Not error sensitive, error correction capability and/or very good error tolerance capability.

- a) To protect against buffer overflow or a protocol malfunction, there is a maximum holding time for each SDU in the GPRS network after which the SDU is discarded. The maximum holding time depends on the protocols used (e.g., TCP/IP).
- b) Corrupt SDU probability: the probability that a SDU will be delivered to the user with an undetected error.

5.6.2.1.3 Delay

GPRS is not a „store and forward“ service - although data is temporarily stored at network nodes during transmission - thus, any delay incurred is due to technical transmission characteristics (or limitations) of the system and is to be minimised for a particular delay class. The delay parameter thus defines the maximum values for the mean delay and 95-percentile delay to be incurred by the transfer of data through the GPRS network(s). The delay parameter defines the end-to-end transfer delay incurred in the transmission of SDUs through the GPRS network(s).

This includes the radio channel access delay (on uplink) or radio channel scheduling delay (on downlink), the radio channel transit delay (uplink and/or downlink paths) and the GPRS-network transit delay (multiple hops). It does not include transfer delays in external networks.

Delay is measured between the R or S (for UE) and Gi (for FS) reference points when applied to "UE to fixed station (FS)" or "FS to UE" transmissions.

Table 5: Delay classes

Delay Class	Delay (maximum values)			
	SDU size: 128 octets		SDU size: 1024 octets	
	Mean Transfer Delay (sec)	95 percentile Delay (sec)	Mean Transfer Delay (sec)	95 percentile Delay (sec)
1. (Predictive)	< 0.5	< 1.5	< 2	< 7
2. (Predictive)	< 5	< 25	< 15	< 75
3. (Predictive)	< 50	< 250	< 75	< 375
4. (Best Effort)	Unspecified			

5.6.2.1.4 Throughput

The throughput parameter indicates the user data throughput requested by the user.

Throughput is defined by two negotiable parameters:

- Maximum bit rate
- Mean bit rate (includes, for example for "bursty" transmissions, the periods in which no data is transmitted.)

The maximum and mean bit rates can be negotiated to a value up to the Information Transfer Rate value (see table 3).

It shall be possible for the network to re-negotiate the throughput parameters at any time during a session.

5.6.2.2 QoS profile - PTP

The subscriber's QoS profile for the PTP service consists of the following parameters which are negotiated or set to default values:

- service precedence (priority),
- reliability,
- delay,
- user data throughput.

5.6.2.3 Monitor

As an option, the UE may monitor the current QoS level. If this option is implemented, the following information shall be monitored:

- user data throughput;
- radio channel access delay;
- round-trip-UE/PLMN delay; and
- reliability,

The UE shall provide means of communicating this information to the application(s) via the R and S reference points as shown in Figure 2.

5.6.3 Packet size

Both PTP and PTM services shall allow the transfer of variable length Network Service Data Units (NSDU).

6 Operational Requirements

6.1 GPRS UE Modes of Operation

The purpose of the definition of the GPRS UE Classes is to enable the different needs of the various market segments to be satisfied by a number of UE types with distinct capabilities (e.g., simultaneous use and number of time-slots [in GERAN](#)). A means shall be provided to indicate the [GERAN](#) multi-slot capability and current configuration to the network when necessary.

Three GPRS UE modes of operation are identified:

NOTE 1: The term simultaneous (attach, traffic, etc.) is the requirement to simultaneously support ~~GSM~~ GPRS services and ~~GSM~~ circuit switched services including SMS.

Class A: The UE is attached to both GPRS and other ~~GSM~~ services. The UE supports simultaneous attach, simultaneous activation, simultaneous monitor, simultaneous in vocation and simultaneous traffic. The mobile user can make and/or receive calls [/sessions](#) on the two services simultaneously subject to the QoS requirements.

~~A minimum of one time slot shall be available for each type of service (circuit switched and GPRS) when required. UTRAN will only support Class A mode of operation.~~

[In GERAN Class A mode of operation may be achieved using Dual Transfer Mode \(DTM\) functionality \[10\].](#)

Class B: The UE is attached to both GPRS and other ~~GSM~~ services, but the UE can only operate one set of services at a time. When the UE is in both idle mode and packet idle mode it should be able to monitor paging channels for both circuit-switched and packet-switched services depending on the mode of network operation.

At least one mode of network operation shall be defined so that when an UE is in both idle mode and packet idle mode it shall be able to respond to paging for both circuit-switched and packet-switched services. A mode of network operation where the network performs the paging for circuit-switched and packet-switched services on different paging channels is also defined. In such case an UE in both idle mode and packet idle mode should either attempt to listen to both paging channels with priority for the circuit-switched service or revert to class-C mode of operation.

If in a mode of network operation the network performs both the paging for circuit-switched and packet-switched services on the same paging channel, then the ~~mobile station~~ UE shall respond to paging messages for both services.

There is no requirement for the UE to monitor the packet paging channel when in dedicated mode.

One mode of network operation shall be defined so that when an UE is engaged in packet data transfer, it shall receive paging messages via the packet data channel without degradation of the packet data transfer. Modes of network operation where paging for other ~~GSM~~ services is not done via the packet data channel are also defined. In such cases an UE engaged in packet data transfer may attempt to receive paging messages.

When responding to a paging message for other ~~GSM~~ services, the UE shall establish the connection for that incoming service (i.e., enter dedicated mode) and suspend GPRS activity. GPRS activity is resumed upon return to idle mode.

If paged for an incoming circuit-switched call, the UE shall indicate the presence of the call to the user or user's application, and where possible provide to the user the CLI. It shall be possible for the user (or the user's application) to decide how to proceed with an incoming call (e.g., accept the call, indicate UDUB, or invoke Call Deflection).

It shall be possible for the UE to receive SMS-CB messages if it attached to GPRS but is not engaged in packet data transfer.

Class B is not applicable to UTRAN or GERAN Iu Mode.

NOTE 2: Users should be aware that monitoring paging (in some modes of network operation), responding to paging, alerting of circuit-switched service, or acceptance or establishment of a circuit-switched call during an active GPRS connection may degrade the performance of the established GPRS connection and, in some cases, may cause failures in an application using the GPRS connection (e.g., a file transfer might be aborted due to a timeout of the application protocol).

Class C: The UE is attached to either GPRS or other ~~GSM~~ services. Alternate use only. If both services (GPRS and Circuit Switched) are supported then a Class C UE can make and/or receive calls only from the manually or default selected service, i.e., either GPRS or Circuit Switched service. The status of the service which has not been selected is detached i.e., not reachable. The capability for GPRS-attached class-C UEs to receive and transmit SMS messages is optional.

The network shall support SMS message reception and transmission for GPRS-attached class-C MSs.

It shall be possible for the UE to receive SMS-CB messages if it attached to GPRS but is not engaged in packet data transfer.

Class C is not applicable to UTRAN.

An UE may be reconfigured. E.g., a class A UE configured as 1 slot for circuit switched plus 1 slot for GPRS may be reconfigured as a class C configured as 0 slots for circuit switched plus 2 slots for GPRS.

Non-voice only UEs do not have to (but may) support emergency calls.

6.2 Subscriber roaming

GPRS shall provide the ability for subscribers to access the service while roaming between networks. This implies the pre-existence of an international signalling mechanism and a service agreement between the different network operators involved.

It shall be possible for GPRS subscribers to remain GPRS attached when moving from one PLMN to another.

HSDPA shall be supported when roaming providing a roaming agreement for the necessary transport/bearer service(s) is currently valid.

6.3 Construction of GPRS subscriber numbers

The number of a GPRS subscriber shall be composed such that the PLMN operator can maintain control of the numbering scheme, thereby ensuring subscriber numbering integrity. The ability to allocate a subset of the numbers privately shall be possible.

6.4 Battery life extension

The GPRS service shall provide for a means to extend the battery life of an UE, by allowing the UE to reduce current drain; e.g., by using a discontinuous reception (DRX) strategy. The power conservation strategy should allow the UE to

remain in a very low current state for a considerable proportion of the time. Moreover, the power conservation strategy should ensure that no messages are lost and that bandwidth is not wasted.

When conserving power through the use of DRX, or other techniques, the UE shall still meet all QoS requirements of selected classes. Some classes of service may necessitate continuous reception (i.e., no DRX capability).

6.5 Format Of Message User Data

The user data is to be presented as an octet string between GPRS's access points, and is not interpreted by the PLMN.

6.6 Charging aspects

The charging information that the GPRS network collects for each UE shall be standardised. The information that the operator uses to generate a bill to a subscriber is operator specific. Billing aspects, e.g. a regular fee for a fixed period, are outside the scope of this specification.

The HPLMN Operator/Service Provider may be able to charge the GPRS subscriber for all costs incurred including those costs incurred in an external network be it a VPLMN or a data network.

The charging requirements of HSDPA shall be identical to the existing packet data services.

6.6.1 PTP and IP-M charging information

The charging information of PTP and IP-M services is collected for the GPRS subscriber. As a minimum the following charging information shall be collected:

- destination and source: The charging information shall describe the destination and source addresses;
- usage of radio interface: The charging information shall describe the amount of data transmitted in MO and MT directions categorized with QoS and user protocols;
- usage of the external data networks: The charging information shall describe the amount of data sent/received to/from the external data network;
- usage of the packet data protocol addresses: The charging information shall describe how long the UE has used the packet data protocol addresses;
- usage of the general GPRS resources: The charging information shall describe the usage of other GPRS related resources and UE's activity in the GPRS network (e.g. Attach/Detach, mobility management);
- location of UE: HPLMN, VPLMN, plus optional higher accuracy location information.

6.6.2 Reverse Charging

It shall be possible to provide reverse charging as a subscription option. However, reverse charging may not be applicable to certain external data network protocols. It shall be possible, as an option, to allow users to roam from one environment to another, between fixed and mobile, between public and private as well as between different public systems.

6.7 Security services

The use of radio communications for transmission to/from subscribers in mobile networks makes them particularly sensitive to:

- 1) misuse of their resources by unauthorized persons using manipulated UEs;
- 2) eavesdropping on the information being exchanged on the radio path.

Therefore, to protect the system in the two cases mentioned above, the following security features are provided for GPRS:

- UE authentication; i.e., the confirmation by the land-based part of the system that the subscriber identity, transferred by the UE within the identification procedure on the radio path, is the one claimed. The purpose of this authentication is to protect the network against unauthorized use. It also enables the protection of GPRS subscribers by denying intruders the ability to impersonate authorized users;
- access control; i.e., the network can support restrictions on access by or to different GPRS subscribers, such as restrictions by location, screening lists, and so on;
- user identity confidentiality; i.e., the property that the user identity on the radio link is not made available or disclosed to unauthorized individuals, entities or processes. The purpose is to provide privacy of identities of the subscribers who are using GPRS radio resources. It allows for the improvement of other security features, e.g., user information confidentiality, and also provides for the protection against tracing the location of a mobile subscriber by listening to the signalling exchanges on the radio path;
- user information confidentiality; i.e., the property that the user information is not made available or disclosed to unauthorized individuals, entities or processes. The purpose is to provide for confidentiality of user data, i.e., protection of the message part pertaining to layers 3 and above, that passes over the radio path.

Both user identity and user data shall be protected as shown in table 6:

Table 6: Protection of user identity and user data

Service	User Identity Protection	User Data Protection
PTP	Yes	Yes
IP-M	Yes	Yes

Security mechanisms available for existing teleservices and bearer services should be used if possible.

6.8 Message Screening

The message screening function is concerned with filtering out unauthorized or unwanted messages. Message screening may be used to restrict the types of message or the volume of data which may be transferred across the GPRS network to/from an individual subscriber.

6.9 GPRS Operator Determined Barring

GPRS subscribers can request packet oriented services from access points within the HPLMN, or from access points within another GPRS enabled PLMN. Similarly, when roaming, a subscriber may request to be connected to an access point within the HPLMN which requires all of the packets to be sent over an international link, which may attract a higher charge from Service Providers. Therefore, similarly to circuit switched domain, barring capability is required.

The specific requirements for ODB of GPRS can be found in [3GPP TS 22.041](#) (Operator Determined Barring) [8].

7 Normal procedures with successful outcome

7.1 Provision

The GPRS services shall be provided to the subscriber after prior arrangement with the service provider. The provision of each of the following GPRS services independently or any combination thereof shall be possible:

- 1) Point To Point - Connectionless Network Service (PTP-CLNS);
- 2) Point To Multipoint (PTM).

It shall be possible to subscribe to GPRS services with or without subscription to other services.

It shall be possible for the network operator to offer GPRS to the Service Provider(s) who may then offer GPRS-based services to the end-user.

GPRS services can be offered to a subscriber with the subscription option of using a password to control the services. A single GPRS-password per subscriber is supported by the network for all GPRS services.

As a subscription option modification of the subscriber's service profile (e.g., registration, erasure) shall be possible only in conjunction with the GPRS-password.

The following Quality of Service (QoS) parameters shall be assigned to the subscriber profile upon provision of the GPRS service(s). These parameters may be negotiated or set to default values:

- service precedence (priority),
- reliability,
- delay,
- user data throughput.
- scheduled repeated transmission.

7.2 Withdrawal

The service(s) shall be withdrawn at the subscriber's request or for administrative reasons. Withdrawal shall de-activate the service.

7.3 GPRS-Attach, GPRS-Detach

GPRS-Attach is performed when the UE indicates its presence to the PLMN for the purpose of using the GPRS PTP or PTM services. This can be immediately after the UE has been switched on or later as the user decides to use the GPRS services. The UE identifies itself with its identity (IMSI, TLLI). A GPRS-Attach shall be successfully performed only if the subscriber has a valid GPRS subscription. It is assumed that the user will not, under normal circumstances, initiate a GPRS Attach without first ensuring that the data handling capability necessary in the terminating equipment has been activated.

GPRS-Detach is performed when the UE indicates to the PLMN that the UE will no longer be using the GPRS services. The UE identifies itself with its identity (IMSI, TLLI).

7.4 Registration

Registration of the service parameters shall enable the subscriber to optimize the actual (dynamic) service profile to the subscriber's present, actual requirements within the limitations of the (static) subscription profile (see subclause 6.1). The result of the registration shall be indicated (i.e. accepted/registered or rejected/not registered). The registered service profile is valid for all GPRS transactions until modified by re-registration or erasure or changes to the subscription profile.

As a subscription option registration of the service parameters shall be possible only in conjunction with a GPRS-password.

It shall be possible for the user to activate connections to non-preconfigured external networks by using non-subscribed Access Point Names (APN's).

Table 7 defines which service parameters shall be able to be registered for the different GPRS services. The range of values for the service parameters is specified in subclause 5.6.

Table 7: Registration of service parameters

Service Parameter	PTP-CLNS	IP-M
Service precedence (priority)	2,3,4	2,3,4
Reliability	2,4	2,4
Throughput	2, 3, 4	2, 3, 4
Simultaneous use class	2	2
Delay	2, 4	2, 4
Security management / encryption	1	1
Interworking profile (a)	2	2
Password Active / De-active	2	2

- Legend:
- 1 Network determined.
 - 2 User determined per subscription and registration.
 - 3 User determined per request.
 - 4 Negotiable.
 - N/A Not applicable.

- a) This is the set of subscription attributes (including a user-ID and/or address valid in the external data network if necessary) adopted by the subscriber when utilizing a particular destination network. A set of subscription attributes is required for each destination network. Multiple user-IDs and/or addresses for each destination network are allowed.

Registration of an identity other than the IMSI (i.e. a user-ID/address in an external data network, e.g. Internet, etc.) is performed to couple this identity to the IMSI for the purpose of accessing (MO and/or MT) the external data network. Registration of an identity other than the IMSI is subject to valid subscription agreements with the network operator. This also provides an effective operator determined barring of access to external data networks.

Each of the registered interworking profiles can be individually activated and de-activated.

Screening parameters can be assigned to a particular interworking profile as a user protection against unwanted costs and/or data.

7.5 Erasure

The subscriber shall be able to erase previously registered service parameter values from the service profile.

Erasure of a non-GSM identity (e.g., Internet) which is currently registered for an interworking profile shall be possible without erasure of the other parameters of the interworking profile.

As a subscription option erasure shall only be possible in conjunction with the GPRS-password.

7.6 Interrogation

The subscriber shall be able to interrogate the status/value of registered service parameters as defined in the current service profile.

7.7 Activation

The subscriber shall be able to activate each of the registered interworking profiles independently within the limitations of the subscription profile. As an option the GPRS network may request the activation of a specific interworking profile for a GPRS attached mobile, when an mobile terminated packet or activation request from external data network with user-ID (e.g. MSISDN) packet is received even if a mobile is inactive. This option may be available for one or more PDP. The activation of the inter-working profile(s) may be performed automatically by the UE immediately after GPRS Attach. When an interworking profile is activated a dynamic binding between the 3GPP identity of the UE and the external data network user-ID and/or address is made by the system, and the appropriate service parameters are applied thus establishing a virtual connection between the UE and the GPRS network. Activation of an interworking profile results in a dynamic binding until de-activation is performed.

7.8 De-activation

The subscriber shall be able to de-activate the previously activated interworking profiles independently within the limitations of the subscription profile thus releasing the previously established virtual connection. An interworking profile(s) shall be automatically de-activated if the provision for the supporting GPRS service is withdrawn. Interworking profiles are deactivated automatically upon GPRS detach..

De-activation of a particular interworking profile shall abort all presently on-going communication between the UE and the external data network.

7.9 Invocation and operation

The GPRS service is invoked upon transmission or reception of GPRS data.

It shall be possible for a UE to be a GPRS service requester and a service receiver. This allows generation and origination of GPRS messages from the mobile termination itself as a standalone GPRS data source. It also allows the mobile termination to provide DCE capabilities for user applications based in terminal equipment outside the mobile termination.

It shall be possible for a subscriber to set-up multiple GPRS communication sessions and maintain these over prolonged periods (e.g. several hours). It shall be possible to establish these connections via more than one external data network. This enables more than one logical data channel to exist to a single mobile termination.

PTP-CLNS and IP-M communications in any combination shall be possible in parallel.

7.10 PIN and Password Management

GPRS-Attach shall only be possible after correct subscriber identification has been confirmed by entry of the current PIN if this option is active. Thus only one PIN is required to gain access to either the Circuit Switched Services/SMS or the GPRS Services or both.

GPRS services can be offered to a subscriber with the subscription option of using a password to control the services. One password per subscriber is supported by the network for all GPRS services. The GPRS password shall be the specified password for supplementary services according to ~~3GPP TS 22.004 [5]~~ and ~~3GPP TS 22.030~~ [TS22.004 \[5\]](#) and [TS22.030 \[6\]](#).

When this option is selected the following actions shall only be performed with the concurrent entry of the password:

- registration, de-registration/erasure;

8 Exceptional procedures

8.1 Provision

None.

8.2 Withdrawal

None.

8.3 Registration

An attempt to register a service or service parameter not available to that subscriber shall result in an indication to the user. The reason shall be indicated:

- the service or service parameter is not supported by the PLMN;
- the subscriber's present (static) subscription profile prohibits the use of this service or service parameter;
- parameter is network determined;
- the entered parameter value is outside the range of that supported by the PLMN.

If, in the case of interworking with an external data network, an attempt is made to set a parameter to a value outside the range of that supported by the interworking to the external data network, it shall be indicated to the user and confirmation required before the parameter value is changed to a value selected by the network.

8.4 Erasure

An attempt to erase a service parameter which is not registered shall result in an indication to the user, the service parameter shall remain in the not registered state.

Erasure of a non-GSM identity (e.g., Internet) which is presently registered as "active" shall result in an indication to the user with a request for confirmation before the de-activation and erasure is performed.

8.5 Interrogation

None.

8.6 Activation

An attempt to activate an interworking profile which is already in the active state shall result in an indication to the user, the interworking profile shall remain in the active state.

8.7 De-activation

An attempt to de-activate an interworking profile which is already in the de-active state shall result in an indication to the user, the interworking profile shall remain in the de-active state.

8.8 Invocation and operation

An attempt to send an MO message with an UE identity which is not valid in the network shall be rejected with an appropriate error status.

An MT message that cannot be delivered due to an invalid UE identity shall be discarded by the network. A message that is received by an incorrect UE shall be discarded by the UE.

8.9 PIN and Password management

PIN and password exceptional procedures are as defined in 3GPP TS 42.017 [7] and 22.004 [5].

9 Addressing

9.1 Point to Point services

A GPRS-PTP subscription is identified by an IMSI.

9.2 Point to Multipoint services

For mobile originated PTM communications the IMSI shall be the basis for the access to the network.

9.3 Overview

How the identities are used within the different services is described in table 8.

Table 8: Services and Identities

Services	mobile originated		mobile terminated
	calling party	Called party	
GPRS PTP	IMSI	Address (note 1)	IMSI
IP-M	IMSI	Address (note 1)	IMSI

NOTE 1: The IMSI or in the case of network interworking refer to subclause 5.2.3.

CHANGE REQUEST

22.060 CR 25 rev 1 Current version: 5.1.0

*For **HELP** on using this form, see bottom of this page or look at the pop-up text over the ☞ symbols.*

Proposed change affects: ☞ (U)SIM ME/UE Radio Access Network Core Network

Title:	☞ Editorial Corrections		
Source:	☞ SA		
Work item code:	☞ CORRECT	Date:	☞ 10 June 2002
Category:	☞ A	Release:	☞ REL-5
	<i>Use <u>one</u> of the following categories:</i> F (correction) A (corresponds to a correction in an earlier release) B (addition of feature), C (functional modification of feature) D (editorial modification) Detailed explanations of the above categories can be found in 3GPP TR 21.900 .		<i>Use <u>one</u> of the following releases:</i> 2 (GSM Phase 2) R96 (Release 1996) R97 (Release 1997) R98 (Release 1998) R99 (Release 1999) REL-4 (Release 4) REL-5 (Release 5)

Reason for change:	☞ UTRAN and GERAN terminology inconsistent with other Stage 1s. Unused references.
Summary of change:	☞ Correction of GERAN and UTRAN Terminology and removal of unnecessary text.
Consequences if not approved:	☞ Stage 1 will not accurately reflect GPRS Service Requirements

Clauses affected:	☞ Various	
Other specs affected:	<input type="checkbox"/> Other core specifications <input type="checkbox"/> Test specifications <input type="checkbox"/> O&M Specifications	☞
Other comments:	☞	

How to create CRs using this form:

Comprehensive information and tips about how to create CRs can be found at <http://www.3gpp.org/specs/CR.htm>. Below is a brief summary:

- 1) Fill out the above form. The symbols above marked ☞ contain pop-up help information about the field that they are closest to.
- 2) Obtain the latest version for the release of the specification to which the change is proposed. Use the MS Word "revision marks" feature (also known as "track changes") when making the changes. All 3GPP specifications can be downloaded from the 3GPP server under <ftp://ftp.3gpp.org/specs/> For the latest version, look for the directory name with the latest date e.g. 2001-03 contains the specifications resulting from the March 2001 TSG meetings.
 - 3) With "track changes" disabled, paste the entire CR form (use CTRL-A to select it) into the specification just in front of the clause

1 Scope

This TS defines the stage one description of the General Packet Radio Service (GPRS). Stage one is an overall service description, primarily from the service subscriber's and user's points of view, but does not deal with the details of the human interface itself. This TS includes information applicable to network operators, service providers and terminal, switch and data base manufacturers.

This TS contains the core requirements for the packet switched networks specified by 3GPP which are sufficient to provide a complete service. It defines a set of bearer services that provide packet mode transmission within the PLMN and interwork with external networks.

The term GPRS shall be used in this document to refer the GPRS service offered via GERAN and UTRAN and the PS Domain of the 3G PLMN.

The GPRS shall not prevent the user's operation of other 3GPP services.

2 References

The following documents contain provisions which, through reference in this text, constitute provisions of the present document.

?? References are either specific (identified by date of publication, edition number, version number, etc.) or non-specific.

?? For a specific reference, subsequent revisions do not apply.

?? For a non-specific reference, the latest version applies. In the case of a reference to a 3GPP document (including a GSM document), a non-specific reference implicitly refers to the latest version of that document *in the same Release as the present document*.

- [1] 3GPP TS 22.001: " Principles of telecommunication services supported by a Public Land Mobile Network (PLMN)".
- [2] 3GPP TS 24.002: " Public Land Mobile Network (PLMN) access reference configuration".
- [3] ISO 8348: "Information processing systems - data communications - network service definition".
- [4] Internet STD 5:RFC 791: Internet protocol, RFC 950: "Internet standard subnetting procedure", RFC 919: "Broadcasting internet datagrams", RFC 922: "Broadcasting internet datagrams in the presence of subnets", RFC 792: "Internet control message protocol", RFC 1112: "Host extensions for IP multicasting" RFC 1122:" Requirements for Internet hosts - communication layers". RFC 1920:" Internet official protocol standards", RFC 1458: "Requirements for multicast protocols", RFC 1301: "Multicast transport protocol".
- [5] 3GPP TS-22.004 (~~ETS 300 918~~): " General on supplementary services".
- [6] 3GPP TS 22.030 (~~ETS 300 907~~): " Man-Machine Interface (MMI) of ~~the Mobile Station (MS)~~[the User Equipment \(UE\)](#)".
- [7] 3GPP TS 42.017 : "Subscriber Identity Modules (SIM) Functional characteristics".
- [8] 3GPP TS 22.041: "Operator Determined Barring (ODB)"
- [9] 3GPP TS 27.060: "General Packet Radio Service (GPRS); Mobile Station (MS) supporting GPRS".
- [10] ~~3GPP TR 21.905: "Vocabulary for 3GPP Specifications"~~[3GPP TS 43.055: Dual Transfer Mode: Stage 2](#)

3 Definitions and abbreviations

3.1 Definitions

For the purposes of this 3GPP TS the following definitions apply:

A

access delay: The value of elapsed time between an access request and a successful access (source: ITU-T X.140).

~~**access protocol:** a defined set of procedures that is adopted at an interface at a specified reference point between a user and a network to enable the user to employ the services and/or facilities of that network (source: ITU-T I.112).~~

accuracy: A performance criterion that describes the degree of correctness with which a function is performed. (The function may or may not be performed with the desired speed.) (source: ITU-T I.350).

B

bearer service: A type of telecommunication service that provides the capability for the transmission of signals between user-network interfaces (source: ~~3GPP TR 21.905 [10]~~, ITU-T I.112).

~~**broadcast:** A value of the service attribute "communication configuration", which denotes unidirectional distribution to all users (source: ITU-T I.113).~~

C

~~**closed group:** A group with a pre-defined set of members. Only defined members may participate in a closed group.~~

conversational service: An interactive service which provides for bi-directional communication by means of real-time (no store-and-forward) end-to-end information transfer from user to user (source: ITU-T I.113).

D

~~**dependability:** A performance criterion that describes the degree of certainty (or surety) with which a function is performed regardless of speed or accuracy, but within a given observational interval (source: ITU-T I.350).~~

destination user: Entity to which calls to the General Packet Radio Service (GPRS) are directed.

F

~~**functional group:** A set of functions that may be performed by a single equipment (source: ITU-T I.112).~~

G

I

interactive service: A service which provides the means for bi-directional exchange of information between users. Interactive services are divided into three classes of services: conversational services, messaging services and retrieval services (source: ITU-T I.113).

interface: The common boundary between two associated systems (source: ~~3GPP TR 21.905 [10]~~, ITU-T I.112).

M

mean bit rate: A measure of throughput. The average (mean) bit rate available to the user for the given period of time (source: ITU-T I.210).

messaging service: An interactive service which offers user-to-user communication between individual users via storage units with store-and-forward, mailbox and/or message handling, (e.g., information editing, processing and conversion) functions (source: ITU-T I.113).

~~**mobile station:** Equipment intended to access a set of PLMN telecommunication services. Services may be accessed while the equipment capable of surface movement within the system area is in motion or during halts at unspecified points.~~

mobile termination: The part of the ~~mobile station~~UE which terminates the radio transmission to and from the network and adapts terminal equipment capabilities to those of the radio transmission ~~(source 3GPP TR 21.905 [10]).~~

multicast service: A unidirectional PTM service in which a message is transmitted from a single source entity to multiple destinations.

multipoint: A value of the service attribute "communication configuration", which denotes that the communication involves more than two network terminations (source: ITU-T I.113).

N

network operator: Entity which provides the network operating elements and resources for the execution of the General Packet Radio Service (GPRS).

network service data unit (NSDU): A unit of data passed between the user and the GPRS network across a Network Service Access Point (NSAP).

network termination: A functional group on the network side of a user-network interface (source: ITU-T I.112).

O

~~**open group:** A group that does not have a pre-defined set of members. Any user may participate in an open group.~~

P

packet: An information unit identified by a label at layer 3 of the OSI reference model (source: ITU-T I.113). A network protocol data unit (NPDU).

packet data protocol (PDP): Any protocol which transmits data as discrete units known as packets, e.g., IP.

packet transfer mode: Also known as packet mode. A transfer mode in which the transmission and switching functions are achieved by packet oriented techniques, so as to dynamically share network transmission and switching resources between a multiplicity of connections (source: ITU-T I.113).

PLMN Operator: Public Land Mobile Network operator. The entity which offers a GPRS.

point-to-multipoint (PTM) service: A service type in which data is sent to "all service subscribers or a pre-defined subset of all subscribers" within an area defined by the Service Requester.

point-to-point (PTP): A value of the service attribute "communication configuration", which denotes that the communication involves only two network terminations.

point-to-point (PTP) service: A service type in which data is sent from a single network termination to another network termination.

protocol: A formal set of procedures that are adopted to ensure communication between two or more functions within the within the same layer of a hierarchy of functions (source: ITU-T I.112).

protocol data unit (PDU): In the reference model for OSI, a unit of data specified in an (N)-protocol layer and consisting of (N)-protocol control information and possibly (N)-user data (source: ITU-T X.200 / ISO-IEC 7498-1).

push service: service type which delivers information (data/multimedia) initiated from a network (which may be external to the PLMN) to the UE. The service will cause a PDP context to be activated if needed.

Q

quality of service: The collective effect of service performances which determine the degree of satisfaction of a user of the service (ITU-T E.800). The set of performance parameters that can be directly observed and measured at the point at which the service is accessed by the user. There are three criteria by which performance is measured: speed, accuracy and dependability (source: ITU-T I.350).

R

reference configuration: A combination of functional groups and reference points that shows possible network arrangements (source: ~~3GPP TR 21.905 [10]~~, ITU-T I.112).

reference point: A conceptual point at the conjunction of two non-overlapping functional groups (source: ~~3GPP TR 21.905 [10]~~, ITU-T I.112).

retrieval service: An interactive service which provides the capability of accessing information stored in data base centres. The information will be sent to the user on demand only. The information is retrieved on an individual basis, i.e., the time at which an information sequence is to start is under the control of the user (source ITU-T I.113).

S

~~**SDU loss probability:** The ratio of total lost service data units (SDUs) to total transmitted service data units in a specified sample (source: ITU-T X.140).~~

~~NOTE: — the source document term "user information unit" has been replaced by the term "service data unit".~~

~~NOTE: — the source document term "user information unit" has been replaced by the term "service data unit".~~

~~**SDU transfer delay:** The value of elapsed time between the start of transfer and successful transfer of a specified service data unit (SDU) (source: ITU-T X.140).~~

~~NOTE: — the source document term "user information unit" has been replaced by the term "service data unit".~~

~~**SDU transfer rate:** The total number of successfully transferred service data units (SDUs) in a transfer sample divided by the input/output time for that sample. The input/output time is the larger of the input time or the output time for the sample (source: ITU-T X.140).~~

~~NOTE: — the source document term "user information unit" has been replaced by the term "service data unit".~~

~~**service access point (SAP):** In the reference model for OSI, the points through which services are offered to an adjacent higher layer (source: 3GPP TR 21.905 [10], ITU-T X.200 / ISO-IEC 7498-1).~~

service attribute: A specified characteristic of a telecommunication service (source: ITU-T I.112).

NOTE: the value(s) assigned to one or more service attributes may be used to distinguish that telecommunications service from others.

~~**service bit rate:** The bit rate that is available to a user for the transfer of user information (source: ITU-T I.113).~~

~~**service category or service class:** A service offered to the users described by a set of performance parameters and their specified values, limits or ranges. The set of parameters provides a comprehensive description of the service capability.~~

service data unit (SDU): In the reference model for OSI, an amount of information whose identity is preserved when transferred between peer (N+1)-layer entities and which is not interpreted by the supporting (N)-layer entities (source: ITU-T X.200 / ISO-IEC 7498-1).

service delay: The time elapsed from the invocation of the service request, to the corresponding service request indication at the Service Receiver, indicating the arrival of application data.

~~**service model:** A general characterisation of services based upon a QoS paradigm, without specifying the actual performance targets.~~

service provider: Entity which offers the General Packet Radio Service (GPRS) for subscription. The network operator may be the service provider.

service receiver: The entity which receives the service request indication primitive, containing the SDU.

service request: This is defined as being one invocation of the service through a service request primitive.

service requester: The entity which requests the initiation of a GPRS operation, through a service request.

service subscriber: Entity which subscribes to the General Packet Radio Service (GPRS) service.

~~**signalling:** The exchange of information specifically concerned with the establishment and control of connections, and with management, in a telecommunications network (source: ITU-T I.112).~~

speed: A performance criterion that describes the time interval required to perform a function or the rate at which the function is performed. (The function may or may not be performed with the desired accuracy.) (source: ITU-T I.350).

~~**supplementary service:** A service that modifies or supplements a basic telecommunication service (as defined in 3GPP TR 21.905 [10]). It cannot be offered to a customer as a stand-alone service. It must be offered together or in association with a basic telecommunication service (bearer or teleservice). The same supplementary service may be common to a number of telecommunication services (source: ITU-T I.210).~~

T

~~**telecommunication service:** That which is offered by a PLMN operator or service provider to its customers in order to satisfy a specific telecommunication requirement. (source: 3GPP TR 21.905 [10], ITU-T I.112). Telecommunication services are divided into two broad families: bearer services and teleservices (source: ITU-T I.210).~~

~~**teleservice:** A type of telecommunication service that provides the complete capability, including terminal equipment functions, for communication between users according to protocols established by agreement between Administrations (source: 3GPP TR 21.905 [10], ITU-T I.112).~~

~~**terminal equipment:** Equipment that provides the functions necessary for the operation of the access protocols by the user (source: 3GPP TR 21.905 [10]). A functional group on the user side of a user-network interface (source: ITU-T I.112).~~

throughput: A parameter describing service speed. The number of data bits successfully transferred in one direction between specified reference points per unit time (source: ITU-T I.113).

transit delay: A parameter describing service speed. The time difference between the instant at which the first bit of a protocol data unit (PDU) crosses one designated boundary (reference point), and the instant at which the last bit of the PDU crosses a second designated boundary (source: ITU-T I.113).

U

~~**user access or user-network access:** The means by which a user is connected to a telecommunication network in order to use the services and/or facilities of that network (source: 3GPP TR 21.905 [10], ITU-T I.112).~~

~~**user-network interface:** The interface between the terminal equipment and a network termination at which interface the access protocols apply (source: ITU-T I.112).~~

~~**user-user protocol:** A protocol that is adopted between two or more users in order to ensure communication between them (source: ITU-T I.112).~~

V

variable bit rate service: A type of telecommunication service characterised by a service bit rate specified by statistically expressed parameters which allow the bit rate to vary within defined limits (source: ITU-T I.113).

3.2 Abbreviations

For the purposes of this 3GPP TS the following definitions apply:

CLNP	Connectionless network protocol
CLNS	Connectionless network service
EGPRS	Enhanced GPRS
FFS	For further study
GPRS	General packet radio service
HSDPA	High Speed Downlink Packet Access
IP	Internet protocol
IP-M	Internet protocol multicast
NSDU	Network service data unit
PDP	Packet data protocol
PDU	Protocol data unit
PLMN	Public land mobile network
PTM	Point to multipoint
PTP	Point to point
QoS	Quality of service

SAP	Service access point
SVC	Switched virtual circuit
SDU	Service data unit
TBD	To be defined
TLLI	Temporary link level identity

4 Main Concepts

The GPRS allows the service subscriber to send and receive data in an end-to-end packet transfer mode, without utilizing network resources in circuit switched mode.

GPRS enables the cost effective and efficient use of network resources for packet mode data applications e.g. for applications that exhibit one or more of the following characteristics:

- intermittent, non-periodic (i.e., bursty) data transmissions, where the time between successive transmissions greatly exceeds the average transfer delay;
- frequent transmissions of small volumes of data, for example transactions consisting of less than 500 octets of data occurring at a rate of up to several transactions per minute;
- infrequent transmission of larger volumes of data, for example transactions consisting of several kilobytes of data occurring at a rate of up to several transactions per hour.

Within the GPRS, two different bearer service types are defined. These are:

- Point-To-Point (PTP);
- Point-To-Multipoint (PTM).

Based on standardized network protocols supported by the GPRS bearer services, a GPRS network administration may offer (or support) a set of additional services. This is outside the scope of this specification, however, a number of possible PTP interactive teleservices include:

- retrieval services which provide the capability of accessing information stored in data base centres. The information is sent to the user on demand only. An example of one such service in the Internet's World Wide Web (WWW);
- messaging services which offer user-to-user communication between individual users via storage units with store-and-forward mailbox, and/or message handling (e.g., information editing, processing and conversion) functions;
- conversational services which provide bi-directional communication by means of real-time (no store-and-forward) end-to-end information transfer from user to user. An example of such a service is the Internet's Telnet application;
- tele-action services which are characterized by low data-volume (short) transactions, for example credit card validations, lottery transactions, utility meter readings and electronic monitoring and surveillance systems.

Some examples of teleservices which may be supported by a PTM bearer service include:

- distribution services which are characterized by the unidirectional flow of information from a given point in the network to other (multiple) locations. Examples may include news, weather and traffic reports, as well as product or service advertisements;
- dispatching services which are characterized by the bi-directional flow of information from a given point in the network (dispatcher) and other (multiple) users. Examples include taxi and public utility fleet services;
- conferencing services which provide multi-directional communication by means of real-time (no store-and-forward) information transfer between multiple users.

EGPRS is an enhancement of GPRS for GERAN allowing higher data rates on the radio interface. The same set of services provided by GPRS is available in EGPRS.

HSDPA is an enhancement to Packet data services for UTRAN allowing higher data rates on the radio interface downlink. The same set of services provided by GPRS is available with GPRS using HSDPA.

5 Service Requirements

5.1 GPRS reference model

The GPRS can be described using the simplified reference model in figure 1.

GPRS provides data transfer capabilities between a sending entity and one or more receiving entities. These entities may be an UE or a Terminal Equipment, the latter being attached either to a GPRS network or to an external data network. The base station provides radio channel access for UEs to the GPRS network. User data may be transferred between four types of UEs as described in ~~3GPP TS 22.001 [1]~~ and ~~3GPP TS 22.001 [1]~~ and TS 24.002 [2].

Each PLMN has two access points, the radio interface (labelled Um for GERAN and Uu for UTRAN) used for mobile access and the R reference point used for origination or reception of messages. The R reference point for the UEs is defined in 27.060 [9].

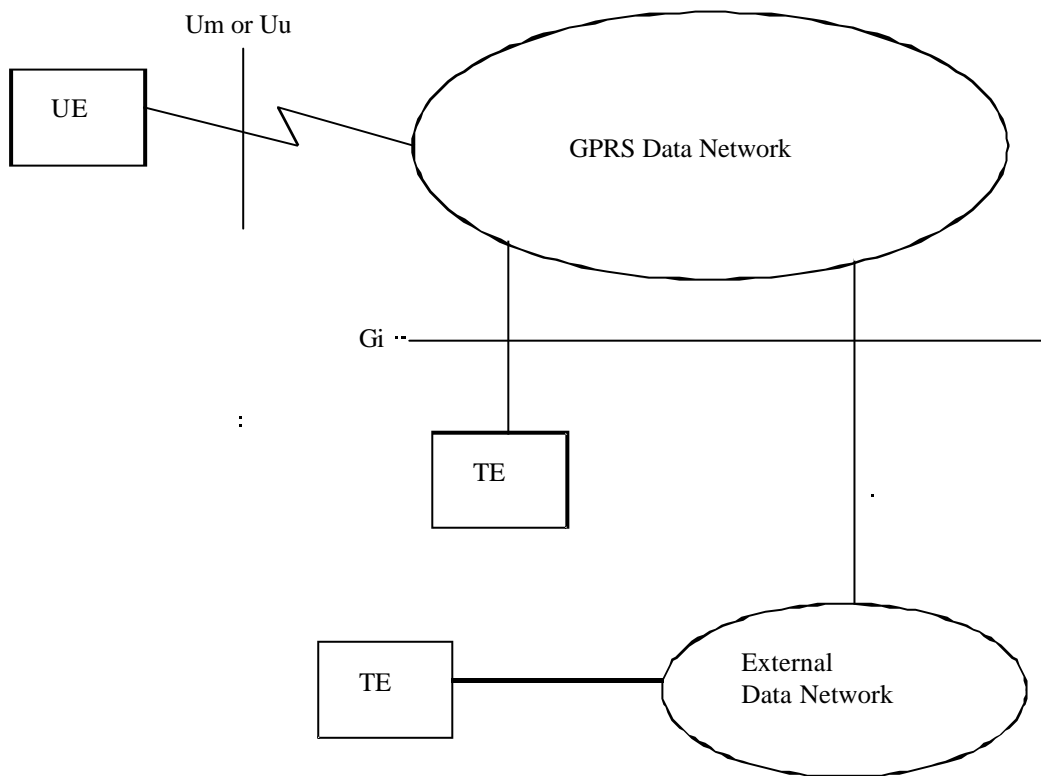

Figure 1: GPRS simplified reference model

5.1.1 Bearer services

The GPRS bearer services support the capability to transmit data between user-network access points.

5.1.2 (Void)

5.1.3 (Void)

5.2 Network Interworking

Network interworking is required whenever a PLMN and a non-PLMN are involved in the execution of a GPRS Service request.

In general the mobile user of a GPRS network will receive and experience all the services provided by an external data network. In this case the external data network refers to the network that the GPRS PLMN interworks with as determined by the network operator. With this in mind it can be said that a user :-

- 1) will require a universal identity(ies) of the form compatible with the interworked with network(s);
- 2) and experience access to and provision of all services as offered by the interworked with networks (some reduction of capability may result from unavoidable restrictions due to the complexity of implementation).

5.2.1 Interworking with other data networks and other PLMNs

GPRS shall provide means to interwork with external data networks. The GPRS operator may provide an appropriate address to the external data network for the subscriber as part of the GPRS subscription. That address can be either dynamic (e.g. the user's IP address is allocated from a pool of unused IP addresses every time the subscriber activates the access to an IP network) or static (e.g. a certain IP address is permanently allocated to a particular subscriber). In addition, the GPRS network shall be able to notify the server IP address (e.g. the gateway IP address) to the subscriber, when the subscriber activates. When connected with some external data networks, the routing protocols of these networks may limit the data network addresses that can be allocated. For example, when interworking with IP networks, the IP address for the GPRS subscriber shall belong to that GPRS operator's IP subnetwork that allocates the address. In the case of a simple point to point connection, a GPRS subscriber need not have an associated network address.

The type of interworking between a PLMN and data networks is determined by the network operator.

Interworking with the following types of data networks shall be defined:

- IP networks;
- other PLMNs, directly or via a transit network.

5.2.1.1 QoS when Interworking

GPRS shall satisfy, within the constraints introduced by the mobile radio environment, the QoS requirements of the interworked-with network.

5.2.2 GPRS Numbering Plan

It is required that GPRS UE addresses conform to the numbering plan already defined for 3GPP system.

5.2.3 Addressing and routing requirements

5.2.3.1 PTP network layer services

A GPRS subscriber identified by an IMSI, may have a network layer address(es) temporarily and/or permanently associated with it that conforms to the standard addressing scheme of the respective network layer service used, e.g.:

- IP Version 4 and 6 addresses for Internet CLNS.

In the case of a simple point to point connection, a GPRS subscriber need not have an associated network layer address.

5.2.4 Interworking for subscriber roaming

Interworking between different GPRS PLMNs is required in order to support subscriber roaming.

It shall be possible for the VPLMN to provide access to the external data network when the external non-3GPP data network address is dynamically assigned by the VPLMN.

5.3 GPRS service description

There are two categories of GPRS services:

- Point to Point (PTP) services,
- Point to Multipoint (PTM) services.

The PTP service provides a transmission of one or more packets between two users, initiated by a service requester and received by a receiver.

There is one PTP service: - PTP Connectionless Network Service (PTP-CLNS). The PTM service provides a transmission of packets between a service requester and a receiver group.

There is one PTM service:

- IP Multicast (IP-M).

An invocation of the service request by a service requester is possible from the fixed and mobile access points.

Table 1 presents the relationship between service requests and the Service Requester/Receiver.

Table 1: Relationship of service request and service requester/receiver

Service requester/receiver AP = Access Point	Types of service request	
	PTP-CLNS	IP-M
From fixed AP to mobile AP	Supported	Supported
From mobile AP to mobile AP (see note 1)	Supported	Supported
From mobile AP to fixed AP	Supported	Supported
NOTE 1: It shall be possible to transfer data between two mobiles of the same operator without the use of external data networks.		

5.3.1 Point-To-Point Connectionless Network Service (PTP-CLNS)

Point-To-Point Connectionless Network Service (PTP-CLNS) is a service in which one (or more) single packet(s) is (are) sent from a single service subscriber "A" to a single destination user "B". Each packet is independent of the preceding and succeeding packet. This service is of the datagram type and is intended to support bursty applications. On the radio interface PTP-CLNS supports the acknowledged transfer mode for reliable delivery.

GPRS provides data communications services consistent with the connectionless network layer service definition ISO 8348 [3]. Specifically, GPRS shall be able to support applications based on the following network layer protocol:

- Internet Protocol (IP);
- IP is the network layer protocol of the Internet TCP/IP protocol suite defined by Internet STD 5 [4].

5.3.2 (Void)

5.3.3 Point-To-Multipoint (PTM) service overview

A PTM service is the transmission of a single message to multiple subscribers. The GPRS PTM services provide the capability for a subscriber to send data to multiple destinations.

There is one PTM service:

- IP Multicast (IP-M), which is a service defined as a part of the IP protocol suite. In IP-M messages are sent between participants of an IP-M group. An IP-M group can be internal to the PLMN or distributed across the Internet. Participation and data transfer in the IP-M service shall be compliant with the Internet protocols. See RFC 1920 [4], RFC 1458 [4], RFC 1301 [4] and RFC 1112 [4]. The Service Receiver of a point-to-multipoint service request shall be able to filter out packets at a network level, through use of the Packet Identities, which are of no interest either because they are for a service for which no subscription is held, or the packet belongs to a sub-group within the offered application service which is of no interest. It is required that the UE-Application resources shall not be utilized for this function.

Table 2: PTM Service Characteristics

Characteristics	IP-M
Primary addressing mechanism	specified group of subscribers
Secondary addressing mechanism	no
Present subscribers known	yes, group members shall join the IP-M call to become participants.
Delivery time	real time
Direction of transmission	multi-directional
Reliable delivery	acknowledged as normal IP PTP packets
Ciphering	yes

5.4 Service interworking

It shall be possible for the GPRS PTP services to be utilized as a bearer service for the SMS-MO and SMS-MT services.

5.5 Transfer Characteristics

The packet multiplexing mechanisms developed for GPRS shall be independent of a given channel type. It shall be possible to operate GPRS over low and high capacity channels. Table 3 is only applicable to the GPRS part of the connection.

Table 3: Transfer Characteristics

Attributes		Supported capabilities
Information Transfer Capability		Unrestricted digital information
Information Transfer Mode	Connection mode	Connection orientated, connectionless
	Traffic type (a)	Variable bit rate and variable delay
	Timing end-to-end (b)	Asynchronous
Information Transfer Rate (c)		Maximum bit rate.
Information Structure		- Service data unit integrity - Data sequence integrity
Communication Configuration		- Point to point - Point to multipoint
Establishment of Communication (d)		Dem and mobile originated or mobile terminated
Negotiation		- Out of band - In band
Symmetry		- Bi-directional - Unidirectional
Radio Channel assignment		Shared, multi-user

- a) Traffic type: describing data streams with constant bit rate or variable bit rate characteristics.
- b) Timing end-to-end: describing the timing relation between the source and destination of signals.
- c) Flexible channels with a maximum bit rate that depends on the type of channel and the number of time slots [in GERAN](#) that are used. This capability defines the maximum capability associated with the channel(s). The actual bit rate for a particular user may be any value up to this maximum value.
- d) Establishment of communication: may be on demand, reserved or permanent.

5.6 Service characteristics

5.6.1 Subscriber profile

The subscriber profile holds subscription information about services and other parameters that have been assigned for an agreed contractual period. It includes the following information:

- subscribed services (PTP-CLNS);
- subscribed QoS profile (service precedence(priority), reliability, delay, throughput).

An invocation of a service by any user with the appropriate subscription profile shall be possible.

It shall be possible to validate a service request against a service subscriber's subscription profile.

5.6.2 Quality of Service (QoS)

The mapping of user application QoS parameters to GPRS QoS parameters is an implementation issue and is not part of GPRS specifications.

It shall be possible to respond to local data traffic conditions adaptively. GPRS shall include the functionality to increase or decrease the amount of radio resources allocated to GPRS on a dynamic basis. The criteria used to decide on dynamic changes of the GPRS part of the radio resource should not be specified. Thus, only the necessary procedure, including radio protocol and timers, needed to perform the change of radio resources shall be specified within the ETSI specifications.

Within GPRS the dynamic allocation of the radio resource for bursty or lengthy file transfer applications shall be such that it can be controlled by the network operator.

5.6.2.1 QoS parameter definitions

The defined QoS parameter values, assume the user is at a location with acceptable -coverage and refer to and are valid for normal network operating conditions or, as in the case of the service precedence parameter, regulate how the network shall handle abnormal conditions.

5.6.2.1.1 Service precedence (priority)

The service precedence indicates the relative priority of maintaining the service. For example under abnormal conditions (e.g. network congestion) packets which may be discarded can be identified. The following precedence levels are defined:

- High precedence: Service commitments will be maintained ahead of all other precedence levels.
- Normal precedence: Service commitments will be maintained ahead of low priority users.
- Low precedence: Service commitments will be maintained after the high and normal priority commitments have been fulfilled.

5.6.2.1.2 Reliability

The reliability parameter indicates the transmission characteristics that are required by an application. The reliability class defines the probability of loss of, duplication of, mis -sequencing of or corruption of SDUs.

Table 4 lists the three classes of the data reliability.

Table 4: Reliability classes

Reliability class	Lost SDU probability (a)	Duplicate SDU probability	Out of Sequence SDU probability	Corrupt SDU probability (b)	Example of application characteristics.
1	10^{-9}	10^{-9}	10^{-9}	10^{-9}	Error sensitive, no error correction capability, limited error tolerance capability.
2	10^{-4}	10^{-5}	10^{-5}	10^{-6}	Error sensitive, limited error correction capability, good error tolerance capability.
3	10^{-2}	10^{-5}	10^{-5}	10^{-2}	Not error sensitive, error correction capability and/or very good error tolerance capability.

- a) To protect against buffer overflow or a protocol malfunction, there is a maximum holding time for each SDU in the GPRS network after which the SDU is discarded. The maximum holding time depends on the protocols used (e.g., TCP/IP).
- b) Corrupt SDU probability: the probability that a SDU will be delivered to the user with an undetected error.

5.6.2.1.3 Delay

GPRS is not a „store and forward“ service - although data is temporarily stored at network nodes during transmission - thus, any delay incurred is due to technical transmission characteristics (or limitations) of the system and is to be minimised for a particular delay class. The delay parameter thus defines the maximum values for the mean delay and 95-percentile delay to be incurred by the transfer of data through the GPRS network(s). The delay parameter defines the end-to-end transfer delay incurred in the transmission of SDUs through the GPRS network(s).

This includes the radio channel access delay (on uplink) or radio channel scheduling delay (on downlink), the radio channel transit delay (uplink and/or downlink paths) and the GPRS-network transit delay (multiple hops). It does not include transfer delays in external networks.

Delay is measured between the R or S (for UE) and Gi (for FS) reference points when applied to "UE to fixed station (FS)" or "FS to UE" transmissions.

Table 5: Delay classes

Delay Class	Delay (maximum values)			
	SDU size: 128 octets		SDU size: 1024 octets	
	Mean Transfer Delay (sec)	95 percentile Delay (sec)	Mean Transfer Delay (sec)	95 percentile Delay (sec)
1. (Predictive)	< 0.5	< 1.5	< 2	< 7
2. (Predictive)	< 5	< 25	< 15	< 75
3. (Predictive)	< 50	< 250	< 75	< 375
4. (Best Effort)	Unspecified			

5.6.2.1.4 Throughput

The throughput parameter indicates the user data throughput requested by the user.

Throughput is defined by two negotiable parameters:

- Maximum bit rate
- Mean bit rate (includes, for example for "bursty" transmissions, the periods in which no data is transmitted.)

The maximum and mean bit rates can be negotiated to a value up to the Information Transfer Rate value (see table 3).

It shall be possible for the network to re-negotiate the throughput parameters at any time during a session.

5.6.2.2 QoS profile - PTP

The subscriber's QoS profile for the PTP service consists of the following parameters which are negotiated or set to default values:

- service precedence (priority),
- reliability,
- delay,
- user data throughput.

5.6.2.3 Monitor

As an option, the UE may monitor the current QoS level. If this option is implemented, the following information shall be monitored:

- user data throughput;
- radio channel access delay;
- round-trip-UE/PLMN delay; and
- reliability,

The UE shall provide means of communicating this information to the application(s) via the R and S reference points as shown in Figure 2.

5.6.3 Packet size

Both PTP and PTM services shall allow the transfer of variable length Network Service Data Units (NSDU).

6 Operational Requirements

6.1 GPRS UE Modes of Operation

The purpose of the definition of the GPRS UE Classes is to enable the different needs of the various market segments to be satisfied by a number of UE types with distinct capabilities (e.g., simultaneous use and number of time-slots [in GERAN](#)). A means shall be provided to indicate the [GERAN](#) multi-slot capability and current configuration to the network when necessary.

Three GPRS UE modes of operation are identified:

NOTE 1: The term simultaneous (attach, traffic, etc.) is the requirement to simultaneously support ~~GSM~~-GPRS services and ~~GSM~~-circuit switched services including SMS.

Class A: The UE is attached to both GPRS and other ~~GSM~~-services. The UE supports simultaneous attach, simultaneous activation, simultaneous monitor, simultaneous invocation and simultaneous traffic. The mobile user can make and/or receive calls [/sessions](#) on the two services simultaneously subject to the QoS requirements.

~~A minimum of one time slot shall be available for each type of service (circuit switched and GPRS) when required.~~ [UTRAN will only support Class A mode of operation](#)

[In GERAN Class A mode of operation may be achieved using Dual Transfer Mode \(DTM\) functionality \[10\]](#)

Class B: The UE is attached to both GPRS and other ~~GSM~~-services, but the UE can only operate one set of services at a time. When the UE is in both idle mode and packet idle mode it should be able to monitor paging channels for both circuit-switched and packet-switched services depending on the mode of network operation.

At least one mode of network operation shall be defined so that when an UE is in both idle mode and packet idle mode it shall be able to respond to paging for both circuit-switched and packet-switched services. A mode of network operation where the network performs the paging for circuit-switched and packet-switched services on different paging channels is also defined. In such case an UE in both idle mode and packet idle mode should either attempt to listen to both paging channels with priority for the circuit-switched service or revert to class-C mode of operation.

If in a mode of network operation the network performs both the paging for circuit-switched and packet-switched services on the same paging channel, then the ~~mobile station~~ [UE](#) shall respond to paging messages for both services.

There is no requirement for the UE to monitor the packet paging channel when in dedicated mode.

One mode of network operation shall be defined so that when an UE is engaged in packet data transfer, it shall receive paging messages via the packet data channel without degradation of the packet data transfer. Modes of network operation where paging for other ~~GSM~~-services is not done via the packet data channel are also defined. In such cases an UE engaged in packet data transfer may attempt to receive paging messages.

When responding to a paging message for other ~~GSM~~-services, the UE shall establish the connection for that incoming service (i.e., enter dedicated mode) and suspend GPRS activity. GPRS activity is resumed upon return to idle mode.

If paged for an incoming circuit-switched call, the UE shall indicate the presence of the call to the user or user's application, and where possible provide to the user the CLI. It shall be possible for the user (or the user's application) to decide how to proceed with an incoming call (e.g., accept the call, indicate UDUB, or invoke Call Deflection).

It shall be possible for the UE to receive SMS-CB messages if it attached to GPRS but is not engaged in packet data transfer.

[Class B is not applicable to UTRAN or GERAN Iu Mode](#)

NOTE 2: Users should be aware that monitoring paging (in some modes of network operation), responding to paging, alerting of circuit-switched service, or acceptance or establishment of a circuit-switched call during an active GPRS connection may degrade the performance of the established GPRS connection and, in some cases, may cause failures in an application using the GPRS connection (e.g., a file transfer might be aborted due to a timeout of the application protocol).

Class C: The UE is attached to either GPRS or other ~~GSM~~ services. Alternate use only. If both services (GPRS and Circuit Switched) are supported then a Class C UE can make and/or receive calls only from the manually or default selected service, i.e., either GPRS or Circuit Switched service. The status of the service which has not been selected is detached i.e., not reachable. The capability for GPRS-attached class-C UEs to receive and transmit SMS messages is optional.

The network shall support SMS message reception and transmission for GPRS-attached class-C MSs.

It shall be possible for the UE to receive SMS-CB messages if it attached to GPRS but is not engaged in packet data transfer.

[Class C is not applicable to UTRAN](#)

An UE may be reconfigured. E.g., a class A UE configured as 1 slot for circuit switched plus 1 slot for GPRS may be reconfigured as a class C configured as 0 slots for circuit switched plus 2 slots for GPRS.

Non-voice only UEs do not have to (but may) support emergency calls.

6.2 Subscriber roaming

GPRS shall provide the ability for subscribers to access the service while roaming between networks. This implies the pre-existence of an international signalling mechanism and a service agreement between the different network operators involved.

It shall be possible for GPRS subscribers to remain GPRS attached when moving from one PLMN to another.

HSDPA shall be supported when roaming providing a roaming agreement for the necessary transport/bearer service(s) is currently valid.

6.3 Construction of GPRS subscriber numbers

The number of a GPRS subscriber shall be composed such that the PLMN operator can maintain control of the numbering scheme, thereby ensuring subscriber numbering integrity. The ability to allocate a subset of the numbers privately shall be possible.

6.4 Battery life extension

The GPRS service shall provide for a means to extend the battery life of an UE, by allowing the UE to reduce current drain; e.g., by using a discontinuous reception (DRX) strategy. The power conservation strategy should allow the UE to remain in a very low current state for a considerable proportion of the time. Moreover, the power conservation strategy should ensure that no messages are lost and that bandwidth is not wasted.

When conserving power through the use of DRX, or other techniques, the UE shall still meet all QoS requirements of selected classes. Some classes of service may necessitate continuous reception (i.e., no DRX capability).

6.5 Format Of Message User Data

The user data is to be presented as an octet string between GPRS's access points, and is not interpreted by the PLMN.

6.6 Charging aspects

The charging information that the GPRS network collects for each UE shall be standardised. The information that the operator uses to generate a bill to a subscriber is operator specific. Billing aspects, e.g. a regular fee for a fixed period, are outside the scope of this specification.

The HPLMN Operator/Service Provider may be able to charge the GPRS subscriber for all costs incurred including those costs incurred in an external network be it a VPLMN or a data network.

The charging requirements of HSDPA shall be identical to the existing packet data services.

6.6.1 PTP and IP-M charging information

The charging information of PTP and IP-M services is collected for the GPRS subscriber. As a minimum the following charging information shall be collected:

- destination and source: The charging information shall describe the destination and source addresses;
- usage of radio interface: The charging information shall describe the amount of data transmitted in MO and MT directions categorized with QoS and user protocols;
- usage of the external data networks: The charging information shall describe the amount of data sent/received to/from the external data network;
- usage of the packet data protocol addresses: The charging information shall describe how long the UE has used the packet data protocol addresses;
- usage of the general GPRS resources: The charging information shall describe the usage of other GPRS related resources and UE's activity in the GPRS network (e.g. Attach/Detach, mobility management);
- location of UE: HPLMN, VPLMN, plus optional higher accuracy location information.

6.6.2 Reverse Charging

It shall be possible to provide reverse charging as a subscription option. However, reverse charging may not be applicable to certain external data network protocols. It shall be possible, as an option, to allow users to roam from one environment to another, between fixed and mobile, between public and private as well as between different public systems.

6.7 Security services

The use of radio communications for transmission to/from subscribers in mobile networks makes them particularly sensitive to:

- 1) misuse of their resources by unauthorized persons using manipulated UEs;
- 2) eavesdropping on the information being exchanged on the radio path.

Therefore, to protect the system in the two cases mentioned above, the following security features are provided for GPRS:

- UE authentication; i.e., the confirmation by the land-based part of the system that the subscriber identity, transferred by the UE within the identification procedure on the radio path, is the one claimed. The purpose of this authentication is to protect the network against unauthorized use. It also enables the protection of GPRS subscribers by denying intruders the ability to impersonate authorized users;
- access control; i.e., the network can support restrictions on access by or to different GPRS subscribers, such as restrictions by location, screening lists, and so on;
- user identity confidentiality; i.e., the property that the user identity on the radio link is not made available or disclosed to unauthorized individuals, entities or processes. The purpose is to provide privacy of identities of the subscribers who are using GPRS radio resources. It allows for the improvement of other security features, e.g.,

user information confidentiality, and also provides for the protection against tracing the location of a mobile subscriber by listening to the signalling exchanges on the radio path;

- user information confidentiality; i.e., the property that the user information is not made available or disclosed to unauthorized individuals, entities or processes. The purpose is to provide for confidentiality of user data, i.e., protection of the message part pertaining to layers 3 and above, that passes over the radio path.

Both user identity and user data shall be protected as shown in table 6:

Table 6: Protection of user identity and user data

Service	User Identity Protection	User Data Protection
PTP	Yes	Yes
IP-M	Yes	Yes

Security mechanisms available for existing teleservices and bearer services should be used if possible.

6.8 Message Screening

The message screening function is concerned with filtering out unauthorized or unwanted messages. Message screening may be used to restrict the types of message or the volume of data which may be transferred across the GPRS network to/from an individual subscriber.

6.9 GPRS Operator Determined Barring

GPRS subscribers can request packet oriented services from access points within the HPLMN, or from access points within another GPRS enabled PLMN. Similarly, when roaming, a subscriber may request to be connected to an access point within the HPLMN which requires all of the packets to be sent over an international link, which may attract a higher charge from Service Providers. Therefore, similarly to circuit switched domain, barring capability is required.

The specific requirements for ODB of GPRS can be found in [3GPP TS 22.041](#) (Operator Determined Barring) [8].

7 Normal procedures with successful outcome

7.1 Provision

The GPRS services shall be provided to the subscriber after prior arrangement with the service provider. The provision of each of the following GPRS services independently or any combination thereof shall be possible:

- 1) Point To Point - Connectionless Network Service (PTP-CLNS);
- 2) Point To Multipoint (PTM).

It shall be possible to subscribe to GPRS services with or without subscription to other services.

It shall be possible for the network operator to offer GPRS to the Service Provider(s) who may then offer GPRS-based services to the end-user.

GPRS services can be offered to a subscriber with the subscription option of using a password to control the services. A single GPRS-password per subscriber is supported by the network for all GPRS services.

As a subscription option modification of the subscriber's service profile (e.g., registration, erasure) shall be possible only in conjunction with the GPRS-password.

The following Quality of Service (QoS) parameters shall be assigned to the subscriber profile upon provision of the GPRS service(s). These parameters may be negotiated or set to default values:

- service precedence (priority),

- reliability,
- delay,
- user data throughput.
- scheduled repeated transmission.

7.2 Withdrawal

The service(s) shall be withdrawn at the subscriber's request or for administrative reasons. Withdrawal shall de-activate the service.

7.3 GPRS-Attach, GPRS-Detach

GPRS-Attach is performed when the UE indicates its presence to the PLMN for the purpose of using the GPRS PTP or PTM services. This can be immediately after the UE has been switched on or later as the user decides to use the GPRS services. The UE identifies itself with its identity (IMSI, TLLI). A GPRS-Attach shall be successfully performed only if the subscriber has a valid GPRS subscription. It is assumed that the user will not, under normal circumstances, initiate a GPRS Attach without first ensuring that the data handling capability necessary in the terminating equipment has been activated.

GPRS-Detach is performed when the UE indicates to the PLMN that the UE will no longer be using the GPRS services. The UE identifies itself with its identity (IMSI, TLLI).

7.4 Registration

Registration of the service parameters shall enable the subscriber to optimize the actual (dynamic) service profile to the subscriber's present, actual requirements within the limitations of the (static) subscription profile (see subclause 6.1). The result of the registration shall be indicated (i.e. accepted/registered or rejected/not registered). The registered service profile is valid for all GPRS transactions until modified by re-registration or erasure or changes to the subscription profile.

As a subscription option registration of the service parameters shall be possible only in conjunction with a GPRS-password.

It shall be possible for the user to activate connections to non-preconfigured external networks by using non-subscribed Access Point Names (APN's).

Table 7 defines which service parameters shall be able to be registered for the different GPRS services. The range of values for the service parameters is specified in subclause 5.6.

Table 7: Registration of service parameters

Service Parameter	PTP-CLNS	IP-M
Service precedence (priority)	2,3,4	2,3,4
Reliability	2,4	2,4
Throughput	2, 3, 4	2, 3, 4
Simultaneous use class	2	2
Delay	2, 4	2, 4
Security management / encryption	1	1
Interworking profile (a)	2	2
Password Active / De-active	2	2

Legend: 1 Network determined.

2 User determined per subscription and registration.

3 User determined per request.

4 Negotiable.

N/A Not applicable.

- a) This is the set of subscription attributes (including a user-ID and/or address valid in the external data network if necessary) adopted by the subscriber when utilizing a particular destination network. A set of subscription attributes is required for each destination network. Multiple user-IDs and/or addresses for each destination network are allowed.

Registration of an identity other than the IMSI (i.e. a user-ID/address in an external data network, e.g. Internet, etc.) is performed to couple this identity to the IMSI for the purpose of accessing (MO and/or MT) the external data network. Registration of an identity other than the IMSI is subject to valid subscription agreements with the network operator. This also provides an effective operator determined barring of access to external data networks.

Each of the registered interworking profiles can be individually activated and de-activated.

Screening parameters can be assigned to a particular interworking profile as a user protection against unwanted costs and/or data.

7.5 Erasure

The subscriber shall be able to erase previously registered service parameter values from the service profile.

Erasure of a non-GSM identity (e.g., Internet) which is currently registered for an interworking profile shall be possible without erasure of the other parameters of the interworking profile.

As a subscription option erasure shall only be possible in conjunction with the GPRS-password.

7.6 Interrogation

The subscriber shall be able to interrogate the status/value of registered service parameters as defined in the current service profile.

7.7 Activation

The subscriber shall be able to activate each of the registered interworking profiles independently within the limitations of the subscription profile. As an option the GPRS network may request the activation of a specific interworking profile for a GPRS attached mobile, when an mobile terminated packet or activation request from external data network with user-ID (e.g. MSISDN) packet is received even if a mobile is inactive. This option may be available for one or more PDP. The activation of the inter-working profile(s) may be performed automatically by the UE immediately after GPRS Attach. When an interworking profile is activated a dynamic binding between the 3GPP identity of the UE and the external data network user-ID and/or address is made by the system, and the appropriate service parameters are applied thus establishing a virtual connection between the UE and the GPRS network. Activation of an interworking profile results in a dynamic binding until de-activation is performed.

7.8 De-activation

The subscriber shall be able to de-activate the previously activated interworking profiles independently within the limitations of the subscription profile thus releasing the previously established virtual connection. An interworking profile(s) shall be automatically de-activated if the provision for the supporting GPRS service is withdrawn. Interworking profiles are deactivated automatically upon GPRS detach..

De-activation of a particular interworking profile shall abort all presently on-going communication between the UE and the external data network.

7.9 Invocation and operation

The GPRS service is invoked upon transmission or reception of GPRS data.

It shall be possible for a UE to be a GPRS service requester and a service receiver. This allows generation and origination of GPRS messages from the mobile termination itself as a standalone GPRS data source. It also allows the mobile termination to provide DCE capabilities for user applications based in terminal equipment outside the mobile termination.

It shall be possible for a subscriber to set-up multiple GPRS communication sessions and maintain these over prolonged periods (e.g. several hours). It shall be possible to establish these connections via more than one external data network. This enables more than one logical data channel to exist to a single mobile termination.

PTP-CLNS and IP-M communications in any combination shall be possible in parallel.

7.10 PIN and Password Management

GPRS-Attach shall only be possible after correct subscriber identification has been confirmed by entry of the current PIN if this option is active. Thus only one PIN is required to gain access to either the Circuit Switched Services/SMS or the GPRS Services or both.

GPRS services can be offered to a subscriber with the subscription option of using a password to control the services. One password per subscriber is supported by the network for all GPRS services. The GPRS password shall be the specified password for supplementary services according to ~~3GPP TS 22.004 [5] and 3GPP TS 22.030~~ [TS22.004 \[5\] and TS22.030](#) [6].

When this option is selected the following actions shall only be performed with the concurrent entry of the password:

- registration, de-registration/erasure;

8 Exceptional procedures

8.1 Provision

None.

8.2 Withdrawal

None.

8.3 Registration

An attempt to register a service or service parameter not available to that subscriber shall result in an indication to the user. The reason shall be indicated:

- the service or service parameter is not supported by the PLMN;
- the subscriber's present (static) subscription profile prohibits the use of this service or service parameter;
- parameter is network determined;
- the entered parameter value is outside the range of that supported by the PLMN.

If, in the case of interworking with an external data network, an attempt is made to set a parameter to a value outside the range of that supported by the interworking to the external data network, it shall be indicated to the user and confirmation required before the parameter value is changed to a value selected by the network.

8.4 Erasure

An attempt to erase a service parameter which is not registered shall result in an indication to the user, the service parameter shall remain in the not registered state.

Erasure of a non-GSM identity (e.g., Internet) which is presently registered as "active" shall result in an indication to the user with a request for confirmation before the de-activation and erasure is performed.

8.5 Interrogation

None.

8.6 Activation

An attempt to activate an interworking profile which is already in the active state shall result in an indication to the user, the interworking profile shall remain in the active state.

8.7 De-activation

An attempt to de-activate an interworking profile which is already in the de-active state shall result in an indication to the user, the interworking profile shall remain in the de-active state.

8.8 Invocation and operation

An attempt to send an MO message with an UE identity which is not valid in the network shall be rejected with an appropriate error status.

An MT message that cannot be delivered due to an invalid UE identity shall be discarded by the network. A message that is received by an incorrect UE shall be discarded by the UE.

8.9 PIN and Password management

PIN and password exceptional procedures are as defined in ~~3GPP~~ TS 42.017 [7] and 22.004 [5].

9 Addressing

9.1 Point to Point services

A GPRS-PTP subscription is identified by an IMSI.

9.2 Point to Multipoint services

For mobile originated PTM communications the IMSI shall be the basis for the access to the network.

9.3 Overview

How the identities are used within the different services is described in table 8.

Table 8: Services and Identities

Services	mobile originated		mobile terminated
	calling party	Called party	
GPRS PTP	IMSI	Address (note 1)	IMSI
IP-M	IMSI	Address (note 1)	IMSI

NOTE 1: The IMSI or in the case of network interworking refer to subclause 5.2.3.

