

Document for: INFORMATION

**An Open Letter to the
Chairmen of
3GPP & 3GPP2**

The undersigned vendors support the output document from the IP CN Harmonization Workshop (Attachment 1) held in Toronto, Canada, on 3rd and 4th April 2002.

We would like to urge the Members of the two Partnership Projects to find the most appropriate way forward, based on the recommendations in Attachment 1, to establish a common long term vision and core/IP network evolution strategy. We encourage you to consider a joint session on vision and evolution within the framework of the existing Partnership Projects, and to increase cross communication towards maximizing desirable synergies. We would encourage you to keep ITU SSG informed as part of the normal process between the Partnership Projects and ITU.

We also urge that the PPs consider creation of appropriate work items in your respective groups to carry out the work that was outlined in the recommendation of the workshop.

CC:

ITU - WP8F

ITU - SSG

ITU - Project Manager, IMT 2000

The following Vendors support this statement:

Cisco Ericsson Lucent Technologies	Motorola Nortel Networks Qualcomm
---	--

April 24th, 2002

Attachment 1

Recommendations from April 3-4, 2002 IP CN Harmonization Workshop

The following conclusions and recommendations on 3GPP/3GPP2 IP core network harmonization were reached at the IP CN Harmonization Workshop held on April 3-4, 2002 in Toronto, Canada.

Harmonization Goals

It was agreed that the harmonization of 3GPP/3GPP2 IP Multimedia Core Networks is a worthwhile and achievable goal that should be pursued urgently by both PP groups. It is desirable to focus the harmonization efforts to those areas where synergies already exist. In particular it was agreed that priority will be given to harmonization in the areas of:

- OSA/PARLAY based service APIs
- IMS (Referring to the 3GPP IP Multimedia Subsystem and its equivalent in 3GPP2 MMD)

Given that considerable alignment has already occurred in the area of 3GPP and 3GPP2 IMS, it was further agreed that 3GPP and 3GPP2 should adopt:

- A single IMS reference model (at a high level of abstraction, to be extended as appropriate within the 3GPP or 3GPP2)
- Consistent terminology to describe common IMS functional entities

The reference model and terminology are provided in Annex A.

Furthermore, it was agreed that the 3GPP and 3GPP2 should work to ensure:

- Interoperability between the 3GPP IMS mobiles and 3GPP2 IMS mobiles (a 3GPP IMS mobile can set up a session with a 3GPP2 IMS mobile and vice-versa)
- Application level intersystem IMS roaming (given that the mobile supports the visited network's access network and IP transport technology, a 3GPP IMS mobile should be able to roam into a 3GPP2 network and vice-versa)

Annex B provides a non-exhaustive list of issues which 3GPP and 3GPP2 should consider in achieving these interoperability and roaming goals.

Recommendations

In general, the group agreed that duplication of work between the PP groups should be avoided and that existing schedules (e.g., 3GPP Release 5) should not be negatively impacted.

3GPP and 3GPP2 should align the IMS and service aspects of their respective Reference Models.

3GPP2 should utilize 3GPP Release 5 IMS and Parlay 3.1 as the base for their on-going development activities.

3GPP and 3GPP2 should collaborate closely on any requirements to be input into IETF related to SIP extensions and other issues.

3GPP and 3GPP2 should establish formal and informal mechanisms (e.g., joint e-mail exploder) to promote harmonization activities.

3GPP and 3GPP2 should consider routes to joint requirements analysis and joint specification development.

The group agreed that common mobility management is an item for future consideration.

3GPP and 3GPP2 should work together on a common evolution strategy taking into account the vision work in other groups including ITU and IP² AdHoc.

Annex A: IMS Harmonization Network Reference Model

- **The Core IP Network Harmonization Workshop Supports the following for the beyond June 2002 timeframe:**
 - o **Alignment of terms in 3GPP/3GPP2 Reference Models**
 - MMD Subset -> IMS (IP Core Network Multi-media Session Domain)
 - CQM, PCF -> PDF (Policy Decision Function)
 - X-SCM -> X-CSCF (Call Session Control Function, X = P, I, S)
 - L-SCM -> BGCF (Breakout Gateway Control Function)
 - NCGW -> OSA-SCS (OSA Service Capability Server)
 - o **Alignment of functional entities and interfaces**
 - 3GPP/3GPP2 should adopt common functionality where common entities exist as shown in the attached HRM
 - Does not include e.g., 3GPP CSE, 3GPP2 SQM, PS Domain, or CS Domain
 - 3GPP/3GPP2 should adopt common procedures and protocols where common interfaces exist as shown in the attached HRM
 - Does not include e.g., 3GPP Ref. Pt. Gr, Gc, or 3GPP2 Ref. Pt. 21, 22

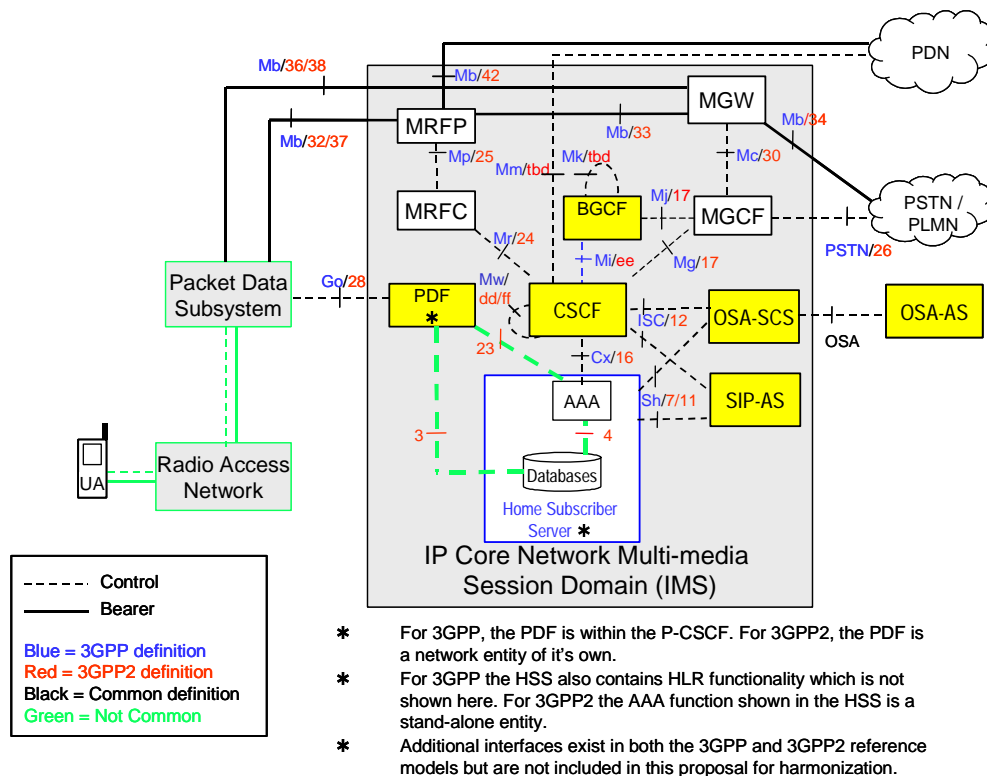

Figure 1. Common 3GPP/3GPP2 Harmonization Reference Model (HRM)

Annex B: IMS Interoperability and Roaming Issues

The following issues need to be considered by 3GPP and 3GPP2 in providing IMS interoperability and application level roaming. This list is not intended to be exhaustive.

Interoperability:

- **Codec interworking:**
 - **Voice calls using different vocoders. Interworking between vocoders is needed.**
 - **Multimedia sessions using different codecs.**
- **Security relationships between**
 - **Network – network (network domain security issues, authentication on a message level, trust relationships between networks)**
 - **Terminal – terminal (any end-2-end encryption, etc.)**
- **IPv4 – IPv6 interoperation**
 - **Terminal to network (e.g., within the SIP messaging)**
 - **Between network entities**
 - **Between networks**

- **End-2-end QoS management**
 - **Consistent use of diffserv**
- **SIP call flows must use identical models, extensions, ...**
- **Charging (e.g., support for “calling party pays”)**
 - **Common data items collected.**
 - **Common protocols to offline billing systems.**
- **Consistent support for**
 - **local services**
 - **emergency calls**
 - **geographic location services**
 - **DTMF**

Roaming:

- **Security relationships between**
 - **Network – terminal (integrity protection, security negotiation, ciphering, ...)**
 - **Network – network (network domain security, inter-system trust relationships, ...)**
- **Mutual authentication (IMS level and above)**
 - **Network – network**
 - **UE – serving network**
 - **UE – home network**
- **Common charging model (serving network needs to capture and provide to the home network all needed data items)**
- **Common SIP model (use identical models, SIP compression, extensions, use the same call flows, ...)**
- **Common QoS understanding for IMS sessions, including authorization and common mapping of diffserv classes**
- **Identities and addressing**
- **Service transparency (proper handling of SIP per the common agreed model)**
- **Consistent support for**
 - **local services**
 - **emergency calls**
 - **geographic location services**
 - **DTMF**