

## **Presentation of Specification to TSG or WG**

---

**Presentation to:** TSG-SA Meeting #7  
**Document for presentation:** GSM TR 06.76, Version 2.0.0  
**Title:** Adaptive Multi-Rate (AMR) Speech Codec;  
Study Phase Report - Release 98  
**Presented for:** Approval

---

**Abstract of document:**

This report contains the AMR Study Phase Report (completed in 1997).  
Prepared to complete an old SMG action point.

---

**Changes since last presentation:**

Never presented to TSG-SA.

---

**Outstanding Issues:**

None

---

**Contentious Issues:**

None

# GSM TR 06.76 V2.0.0 (2000-03)

---

*Technical Report*

**Digital cellular telecommunication system (Phase 2+);  
Adaptive Multi-Rate (AMR) Speech Codec;  
Study Phase Report  
GSM TR 06.76 version 2.0.0 (Release 98)**

---



**GSM**®  
GLOBAL SYSTEM FOR  
MOBILE COMMUNICATIONS

**ETSI** 

---

---

**Reference**

DEN/SMG-? (?).PDF

---

**Keywords**

AMR, CODEC

**ETSI**

---

**Postal address**

F-06921 Sophia Antipolis Cedex - FRANCE

---

**Office address**650 Route des Lucioles - Sophia Antipolis  
Valbonne - FRANCE

Tel.: +33 4 92 94 42 00 Fax: +33 4 93 65 47 16

Siret N° 348 623 562 00017 - NAF 742 C

Association à but non lucratif enregistrée à la  
Sous-Préfecture de Grasse (06) N° 7803/88

---

**Internet**

secretariat@etsi.fr

Individual copies of this ETSI deliverable  
can be downloaded from<http://www.etsi.org>

---

**Copyright Notification**

No part may be reproduced except as authorized by written permission.  
The copyright and the foregoing restriction extend to reproduction in all media.

© European Telecommunications Standards Institute 1999.  
All rights reserved.

---

# Contents

<b>INTELLECTUAL PROPERTY RIGHTS</b> .....	<b>5</b>
<b>FOREWORD</b> .....	<b>5</b>
<b>EXECUTIVE SUMMARY AND RECOMMENDATIONS</b> .....	<b>6</b>
INTRODUCTION.....	6
BENEFITS .....	6
PERFORMANCE .....	6
RISK AREAS .....	7
CODEC DEVELOPMENT AND SELECTION .....	7
RECOMMENDATIONS .....	8
<b>SCOPE</b> .....	<b>9</b>
<b>1. GOALS OF AMR CODEC</b> .....	<b>9</b>
<b>2. TERMINOLOGY</b> .....	<b>9</b>
<b>3. OVERVIEW OF THE AMR SYSTEM AND ITS APPLICATIONS</b> .....	<b>9</b>
3.1. BASIC OPERATION .....	9
3.2. APPLICATION SCENARIOS.....	10
<b>4. DEVELOPMENT TIME-SCALES</b> .....	<b>10</b>
<b>5. BASELINE DESCRIPTION AND WORKING ASSUMPTIONS</b> .....	<b>11</b>
5.1. GENERIC OPERATION.....	11
5.2. CONSTRAINTS .....	12
5.3. SPEECH AND CHANNEL CODECS .....	12
5.4. RATE ADAPTATION.....	13
5.4.1 <i>Channel mode adaptation</i> .....	13
5.4.2 <i>Codec mode adaptation</i> .....	13
5.5. SUPPORT OF TFO.....	14
5.6. SUPPORT OF DTX.....	14
5.7. SUPPORT OF 8 AND 16 KBIT/S A-TER SUB-MULTIPLEXING .....	14
5.8. ACTIVE NOISE SUPPRESSION.....	14
<b>6. FEASIBILITY ISSUES</b> .....	<b>14</b>
6.1. CODEC PERFORMANCE .....	15
6.1.1. <i>Basic, error and background noise performance</i> .....	15
6.1.2. <i>Tandeming</i> .....	16
6.1.3. <i>Seamless codec mode bit-rate changes</i> .....	16
6.1.4. <i>Complexity</i> .....	16
6.2. QUALITY AND CAPACITY BENEFITS OF AMR .....	17
6.2.1 <i>General AMR performance</i> .....	17
6.2.2 <i>Improved coverage from the improved robustness in FR mode</i> .....	18
6.2.3 <i>Capacity benefits from the improved robustness in FR mode</i> .....	18
6.2.4 <i>Quality/capacity trade-offs by use of the HR mode</i> .....	18
6.2.5 <i>System aspects of capacity/quality</i> .....	20
6.2.6 <i>MS penetration</i> .....	20
6.3. CODEC ADAPTATION .....	21
6.3.1 <i>Codec mode</i> .....	21
6.3.2 <i>Channel mode</i> .....	22
6.3.3 <i>Channel metrics (accuracy, update rate)</i> .....	22

6.3.4	<i>Channel dynamics, effects on performance</i> .....	22
6.3.5	<i>Location of codec mode and channel mode control</i> .....	23
6.3.6	<i>Radio resource allocation</i> .....	23
6.4	SUPPORT OF OTHER FEATURES .....	24
6.4.1	<i>TFO</i> .....	24
6.4.2	<i>DTX</i> .....	24
6.4.3	<i>Power control</i> .....	24
6.4.4	<i>Handover</i> .....	25
6.4.5	<i>8 and 16 kbit/s A-ter sub-multiplexing</i> .....	25
6.5	WIDEBAND SERVICE OPTION .....	25
<b>7.</b>	<b>REQUIREMENTS SPECIFICATION</b> .....	<b>26</b>
<b>8.</b>	<b>IMPLEMENTATION FACTORS</b> .....	<b>26</b>
<b>9.</b>	<b>CODEC DEVELOPMENT AND SELECTION</b> .....	<b>27</b>
9.1	TEST AND SELECTION METHODOLOGIES .....	27
9.2	ASYMMETRY OF UP AND DOWN LINKS .....	27
9.3	SPEECH TRAFFIC CHANNEL SIMULATION MODEL .....	27
9.4	SCHEDULE .....	28
9.5	PROGRAMME MANAGEMENT .....	29
<b>10.</b>	<b>OPEN ISSUES AND RISKS</b> .....	<b>29</b>
<b>11.</b>	<b>RECOMMENDATIONS</b> .....	<b>30</b>
<b>ANNEX A</b>	<b>TERMINOLOGY</b> .....	<b>31</b>
<b>ANNEX B</b>	<b>APPLICATION SCENARIOS</b> .....	<b>34</b>
<b>ANNEX C</b>	<b>CODEC REQUIREMENT SPECIFICATION</b> .....	<b>35</b>
C.1	STATIC CONDITIONS .....	35
C.2	DYNAMIC CONDITIONS .....	37
<b>ANNEX D</b>	<b>AMR IMPLEMENTATION REQUIREMENTS</b> .....	<b>38</b>
D.1	NETWORK .....	38
D.2	MS .....	40
<b>ANNEX E</b>	<b>SPEECH TRAFFIC CHANNEL SIMULATOR</b> .....	<b>43</b>
<b>ANNEX F</b>	<b>SCHEDULE FOR AMR DEVELOPMENT</b> .....	<b>44</b>
<b>ANNEX G</b>	<b>WORK ITEM DESCRIPTION FOR AMR</b> .....	<b>46</b>

---

## Intellectual Property Rights

IPRs essential or potentially essential to the present document may have been declared to ETSI. The information pertaining to these essential IPRs, if any, is publicly available for **ETSI members and non-members**, and can be found in SR 000 314: "*Intellectual Property Rights (IPRs); Essential, or potentially Essential, IPRs notified to ETSI in respect of ETSI standards*", which is available **free of charge** from the ETSI Secretariat. Latest updates are available on the ETSI Web server (<http://www.etsi.org/ipr>).

Pursuant to the ETSI IPR Policy, no investigation, including IPR searches, has been carried out by ETSI. No guarantee can be given as to the existence of other IPRs not referenced in SR 000 314 (or the updates on the ETSI Web server) which are, or may be, or may become, essential to the present document.

---

## Foreword

This European Standard (Telecommunications series) has been produced by ETSI Technical Committee Special Mobile Group (SMG), and is now submitted to the ETSI standard One-step Approval Procedure.

The present technical report contains the GSM Adaptive Multi-Rate (AMR) speech codec Study Phase Report.

The content of the present document is subject to continuing work within SMG and may change following formal SMG approval. Should SMG modify the contents of the present document it will be re-released with an identifying change of release date and an increase in version number as follows:

Version 7.x.y, where:

- 7 indicates Release 1998 of GSM Phase 2+
- x the second digit is incremented for all changes of substance, i.e. technical enhancements, corrections, updates, etc.
- y the third digit is incremented when editorial only changes have been incorporated in the specification.

<b>Proposed national transposition dates</b>	
Date of latest announcement of this EN (doa):	3 months after ETSI publication
Date of latest publication of new National Standard or endorsement of this EN (dop/e):	6 months after doa
Date of withdrawal of any conflicting National Standard (dow):	6 months after doa

# Executive summary and recommendations

## Introduction

As tasked by SMG in October '96, SMG11 and SMG2 have conducted a study into the feasibility of the AMR codec concept. The study not only addressed technical feasibility but also the benefits of AMR in realistic applications, the development plan, time-scales and the resources needed to take the AMR codec and associated network support to completion of the standards.

## Benefits

Unlike previous GSM speech codecs which operate at a fixed rate with a fixed level of error protection, the AMR system adapts to local radio channel and traffic conditions and selects the optimum channel (half- or full- rate) and codec mode (speech and channel bit rates) to deliver the best combination of speech quality and capacity. This flexibility provides a number of important benefits:

- Improved speech quality in both half-rate and full-rate modes by means of codec mode adaptation i.e. varying the balance between speech and channel coding for the same gross bit-rate.
- Ability to trade speech quality and capacity smoothly and flexibly by a combination of channel and codec mode adaptation; this can be controlled by the network operator on a cell by cell basis.
- Improved robustness to channel errors under marginal radio signal conditions in full-rate mode. This increased robustness to errors and hence to interference may instead be used to increase capacity by operating a tighter frequency re-use pattern.
- Ability to tailor AMR operation to meet the many different needs of operators.
- Potential for improved handover and power control resulting from additional signaling transmitted rapidly in-band.

To investigate the feasibility of realizing these benefits, a wide-ranging study has been carried out. This has considered not only speech and channel codec performance, but perhaps more critically, channel and codec mode adaptation, the associated signaling and the operation of AMR in realistic radio environments. The one-year timeframe allowed for the Study Phase has prevented a thorough assessment of all aspects. However, it has been possible to assess expected performance (quality and capacity) and to identify and assess the risks of the critical areas from a feasibility perspective.

## Performance

The performance benefits have been estimated for some of the main applications of AMR, assuming certain system assumptions such as frequency hopping and making a number of simplifications:

- In full-rate mode only, the robustness to high error levels is substantially increased such that the quality level of EFR at a C/I of 10dB is extended down to a C/I of 4dB, measured at the input to the channel equalizer. This will give coverage in-fill advantages in areas of marginal radio coverage. This equates to an improvement of sensitivity of between 4 dB and 6 dB depending on the robustness of the signaling channels.
- Quality and capacity can be traded against each other in a controlled manner. Using as a reference an EFR/HR combination with a conventional resource allocation, for the same capacity improvement, AMR will give an *average* quality *improvement* corresponding to about 70% of the difference between FR and EFR. This improvement is relatively insensitive to C/I.

It has also been estimated that for a capacity improvement of about 30% (relative to FR only), 80% of calls would have G.728 quality of better, i.e. "wireline" quality. This tradeoff between % capacity improvement and % of mobiles having wireline quality is sensitive to the local C/I distributions. These have proved to be difficult to estimate reliably. Other individual estimates have shown more optimistic results and the figures quoted probably represent the lower end of the range.

- In half-rate mode only which gives the maximum capacity advantage (in excess of 100% as for normal half-rate), quality improvements are also given (deriving from codec mode adaptation) especially in background noise conditions and at low errors. Under these conditions, the quality level will be at least as good as that of FR.
- The increased resilience channel errors in full-rate mode may allow a tighter frequency re-use giving capacity improvements estimated at up to 30%, but at the expense of lower speech quality. However, it is unclear at present how terminals without AMR e.g. with FR or EFR codecs or data terminals should be handled as they do not have the improved resilience to errors and the speech quality would be degraded. This application requires further study.

## Risk areas

The main performance limitations and technical risk areas have been identified as follows:

- **Codec performance:** to achieve the wireline quality benchmark of G.728 in HR mode, the C/I threshold had to be increased from 10 dB to about 18 dB. This will allow the speech quality target still to be achieved but at the expense of lower capacity gain. This is already reflected in the performance results above.
- **Background noise:** the original performance objective in HR mode was G.728 is better than EFR. This is too demanding and was relaxed to “the better of GSM-FR or G.729” quality for each type of background noise (vehicle, street, office). This still represents a substantial improvement over the existing HR codec.
- The difficulties of measuring C/I distributions representative of high capacity networks using other capacity enhancing techniques (e.g. power control, frequency hopping) has made it difficult to make accurate estimates of capacity and quality. Pessimistic forecasts have therefore been made to illustrate the lower limit. **Risk: medium.**
- **Channel and codec mode adaptation algorithms.** These are crucial to the success of AMR operation and improvements to initial implementations will be possible to optimize performance for real network operating conditions. **Risk: medium.**
- **Channel quality metric.** It is important that the estimate of the channel quality is sufficiently accurate to ensure that the optimum codec mode is selected. While some solutions have been considered, the feasibility of providing such an accurate metric remains a risk.

**Risk assessment by SMG2, high; by SMG11, medium.**

- **TFO.** Although some potential candidate TFO solutions for AMR have been identified, effective solutions will require significant development. **Risk to TFO: medium.**
- **AMR system complexity.** The AMR system is relatively complex and introduces new techniques. **Risk level: medium.**

At the conclusion of the Study Phase, there remain open design issues. However, working assumptions have been reached for most critical areas and other open issues can be resolved in due course without prejudice.

## Codec development and selection

It is recommended that the optimum AMR solution be selected from a number of candidate proposals. To promote integrated solutions with the greatest flexibility for innovative techniques, designers should submit complete solutions including not only the speech and channel codecs, but also the control and signaling system, subject to agreed constraints and working assumptions.

To test the codecs, in addition to traditional static testing for each mode of the codec, dynamic tests will be essential to evaluate performance under dynamically varying radio conditions. New test methodologies for dynamic testing will be needed, as well as new error patterns. These are in the process of being developed.

In response to the requirements declared by the MOU to SMG#20, the possibility of running with a schedule which would deliver the codec and signaling specifications in time for Release '98 has been examined. However, so far a schedule has not been agreed by SMG11 and SMG2, which would meet Release '98



deadlines. The feasibility of achieving Release '98 is therefore unclear although it is evident that such a schedule would have to be very aggressive and high risk. Further urgent discussions are needed by the two committees to reach a conclusion.

For the formal codec testing, independent host and test laboratories will be needed. They will require funding estimated at 400 k ECU.

## Recommendations

On basis of the performance benefits and risks highlighted above, the following recommendations are submitted to SMG for approval:

- Initiate a program to develop, test, select and specify AMR speech and channel codecs together with related features such as VAD, DTX and comfort noise generation. The associated control, signaling procedures and TFO should also be developed and specified.
- SMG11 and SMG2 should agree an acceptable and workable time-plan as soon as possible after SMG#23 with the priority of meeting Release '98 deadlines.
- Approve the performance requirement specification in Annex C.
- SMG to secure funding of 400 kECU for the purposes of codec testing.
- Approve Work Item Description (see Annex G).
- Decide whether to include wideband option on AMR (see separate Liaison Statement).

---

## Scope

This report presents the outcome of the Study Phase initiated at SMG#20 on the concept of the Adaptive Multi-Rate (AMR) codec. The AMR concept represents a new approach to achieving consistent high quality speech combined with efficient spectrum usage. It was recognized at SMG#20 that this would require novel techniques whose feasibility should first be assessed before proceeding with a full development of the AMR system and its control.

Sections 1 to 4 provide an overview and background to the AMR concept. Section 5 provides a basic description of the AMR system functionality including working assumptions that have been agreed during the Study Phase. Feasibility aspects are considered in Section 6. The requirement specification, which will form the basis for the development phase, is contained in Section 7. Section 8 gives an indication of the MS and network upgrades needed to support AMR. Section 9 outlines how the AMR codec will be developed, tested and selected including the proposed time-plan. Sections 10 and 11 conclude with a summary of the risks and recommendations.

---

## 1. Goals of AMR codec

The principal goals of the AMR codec as presented to SMG#20 (October 1996) (see SQSG report, Tdoc SMG 447/96) are to provide

- wireline quality combined with capacity advantages offered by half-rate operation
- increased robustness to high channel error rates when operating at full-rate

This is to be achieved by controlling the channel and codec modes according to the radio channel conditions and traffic loading.

To address the needs of certain GSM markets, especially in the US, and to ensure the earliest provision and penetration of AMR handsets, it was also decided at SMG#20 to set an aggressive time-scale for the development and standardization of the AMR. This requires that the AMR specifications be ready for GSM Release '98, i.e. end of 1998.

---

## 2. Terminology

The terminology and acronyms used in this report are given in Annex A.

---

## 3. Overview of the AMR system and its applications

### 3.1. Basic operation

Most speech codecs including the existing GSM codecs (FR, HR and EFR) operate at a fixed coding rate. Channel protection (against errors) is added also at a fixed rate. The coding rates are chosen as a compromise between best clear channel performance and robustness to channel errors. The AMR system exploits the implied performance compromises by adapting the speech and channel coding rates according to the quality of the radio channel. This gives better clear channel quality and better robustness to errors. These benefits are realized whether operating in full-rate or half-rate channels.

As well as quality improvements, the need to enhance capacity by allocating half-rate channels to some or all mobiles is also recognized. The radio resource algorithm, enhanced to support AMR operation, allocates a half-rate or full-rate channel according to channel quality and the traffic load on the cell in order to obtain the best balance between quality and capacity. It is intended that the control system should not be fixed but can be enhanced as experience of the AMR system is gained on real networks; it may also be tuned to meet particular operator's network needs.

## 3.2. Application scenarios

The AMR codec concept is adaptable not only in terms of its ability to respond to radio and traffic conditions but also to be customized to the specific needs of network operators. There are three levels of adaptation of the AMR system:

- handovers between half-rate and full-rate channels according to traffic demands
- variable partitioning between speech and channel coding bit-rates to adapt to channel conditions in order to obtain best speech quality
- Optimization of channel and codec control algorithms to meet specific operator needs and network conditions.

This allows the codec to be applied in many ways of which three important examples are

- Full-rate only for maximum robustness to channel errors but no capacity advantage. This additional robustness may be used not only to extend coverage in marginal signal conditions, but also to improve capacity through tighter frequency re-use, assuming high AMR MS penetration.
- Half-rate only for maximum capacity advantage; more than 100% capacity increase achievable relative to FR orEFR (i.e. same as existing HR); significant quality improvements relative to existing HR will be given for a large proportion of mobiles as a result of *codec mode* adaptation to channel conditions.
- Mixed half/full rate operation allowing a trade-off between quality and capacity enhancements according to radio and traffic conditions and operator priorities.

This is explained further in Annex B.

---

## 4. Development Time-scales

A number of operators have expressed the urgent requirement for the availability of the AMR system by 1999. This was reflected in a statement from the MOU at SMG#20 when the AMR Study phase was initiated (see Tdoc SMG /96). The target for the completion of the AMR codec specifications has been set for Release '98. Two reasons for this early availability is to reduce the cost of introduction of AMR on networks (lower write-off costs of redundant equipment) and to maximize the opportunity for early AMR handset penetration to optimize the capacity advantage of the codec.

The feasibility of achieving this delivery date has formed part of the Feasibility Study. Consistent with this goal, the Study Phase was restricted to one year notwithstanding the complexity and novelty of the AMR system concept.

### Phased Approach

The early delivery of the AMR codec will reduce the cost of introduction to operators since the network capacity will be less and the write-off costs of redundant equipment lower. Therefore a phased approach is being followed:

Phase 1. The complete AMR speech and channel codecs will be defined, together with the *codec mode adaptation* control processes, possible new link performance metrics and their transmission in-band on the traffic channel.

The *channel mode adaptation* will be based closely on existing intra-cell handover methods in terms of signaling procedures i.e. will rely on the handover command. However, the *channel mode adaptation* decision algorithm will probably be extended and use the currently available metrics, RxQual and RxLev and possible newly defined metrics. This algorithm will be left open to manufacturers to develop and improve with time. Re-packing of half-rate radio channels required by AMR operation will rely again on existing signaling procedures.

The circuit allocation procedures are assumed to be left unchanged. Constraints on the possible codec mode changes may appear for the half-rate mode. In particular, changes between codecs, without channel mode change, may be allowed only if the same Ater bit rate is possible.

Phase 2. This will introduce new mode *adaptation* control algorithms, enhanced by means e.g. of new link quality metrics, more advanced handover, enhanced re-packing algorithms, etc.

Phase 1 should of itself deliver substantial performance benefits both in terms of speech quality and capacity enhancements. The need or otherwise for a more complicated Phase 2 will be determined after Phase 1 is complete.

## 5. Baseline description and working assumptions

This section deals with the basic description of the AMR concept together with a summary of the working assumptions agreed during the feasibility phase. The section also explains the main constraints on the codec design.

### 5.1. Generic operation

The *AMR* codec is a single speech and channel codec whose *channel mode* and *codec mode* bit-rates can be varied to suit the prevailing channel and traffic conditions. The codec can operate in two channel modes, *full-rate* and *half-rate*, corresponding to the TCH/F and TCH/H channels.

For each *channel mode*, the codec speech and channel bit-rates (i.e. the *codec mode* bit-rates), can be varied rapidly (several times a second) to track the channel error rates or C/I of the channel near-instantaneously. This gives significant performance improvement over a corresponding fixed rate codec, which is a compromise between the full range of channel conditions encountered. The channel measurement reports and any other information for the codec mode adaptation will be transmitted in-band in the traffic channel or using stealing flag techniques. The *codec mode* bit-rate can also be varied in consideration of other environmental conditions like the acoustic background noise. This would allow the well-known failures of low bit-rate codecs with high background noise conditions to be dealt with. Adaptation of the codec mode bit-rate driven by the encoder at the MS can be, however, superseded by the network.

In addition, the *channel mode* of the codec can be switched in order to increase channel capacity while maintaining the speech quality to (operator specified) limits. These variations are carried out by means of *AMR handovers*, which will occur far less frequently than the codec mode changes (probably no more than a maximum of a few times per minute). This range of operation of the two *channel-modes* is illustrated in Fig. 5.1. *AMR handovers* may be based on a combination of RxLev and RxQual measurement reports and on new metrics derived from the measurement reports transmitted in-band for *codec mode adaptation*. A conventional HO between HR & FR based only on capacity considerations by the network operator is also possible.

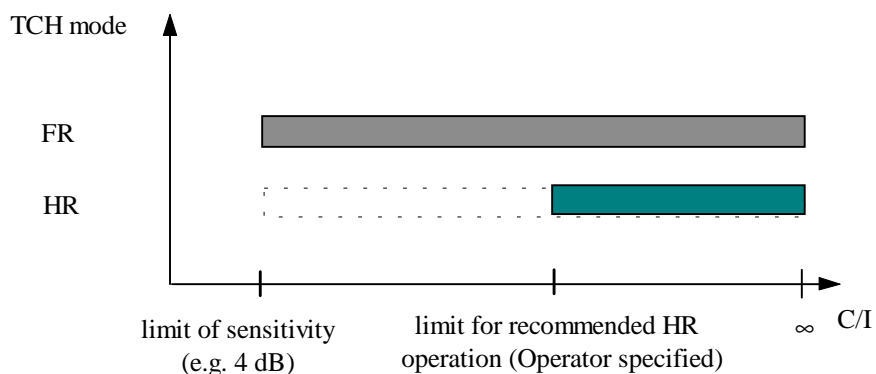

Fig. 5.1 - Preferred operating ranges for HR and FR channel modes.

## 5.2. Constraints

Due to the challenging quality/capacity targets of AMR, the feasibility phase identified the need for a high degree of freedom to be left to the codec proponents in order to meet the requirements. Nonetheless, a number of constraints to the AMR codec design have been identified. They are reported in the following.

**Radio interface.** The AMR codec and its control will operate without any changes to the air-interface channel multiplexing, with the possible exception of the interleave depth. Conventional TCH-F and TCH-H channels will be used for FR and HR *channel modes* of the codec.

**Channel mode handovers.** These will be executed in the same way as existing intra-cell handovers. However, the algorithm used to determine when and whether to perform an AMR handover will be new and specific to the BSS manufacturer.

**Codec mode signaling.** Signaling and measurement reporting for codec mode changes shall be transmitted on the radio interface in-band or using frame stealing flag techniques to avoid the need for new out-of-band signaling channel. Signaling information can be different on the up and down links.

**Frequency hopping.** The greatest quality benefits of AMR will be achieved when frequency hopping is applied. Without it, the benefits may be reduced especially for slow moving or stationary mobiles.

**Power control.** It shall be possible to operate power control independently of the AMR adaptation. However, operators may choose to optimize the AMR control according to the power control settings. Fast power control may also be introduced provided that the measurement reports are transmitted in-band for AMR codec adaptation control.

**TFO.** The AMR codec shall support Tandem Free Operation. TFO shall not decrease the capacity gain achievable using the AMR codec.

**DTX.** The AMR codec shall support DTX operation. The increase in radio channel activity in terms of average transmission power during speech inactivity shall not significantly affect the gain of DTX operation i.e. the interference reduction and the battery saving should be similar to that of current DTX operation.

(See also section 5.6).

**A-ter Sub-multiplexing.** At least one codec mode at HR should be consistent with 8 kbps sub-multiplexing on the A-ter interface (see Section 5.7.).

**Complexity.** The complexity of the channel codec shall be no greater than that of the HR channel codec. The complexity of the source codec shall be no greater than 8 times that of the FR codec.

## 5.3 Speech and channel codecs

The AMR codec will operate at a number of different codec mode bit-rates for each of the two channel modes (FR and HR). The precise number of modes for each channel is left open to be decided by the codec proponent. It has a strong dependency on the codec mode adaptation algorithm employed. Each of these codec modes is expected to provide different performance as a function of the channel quality (C/I) that can be represented by a family of curves like those reported in Fig. 5.2.

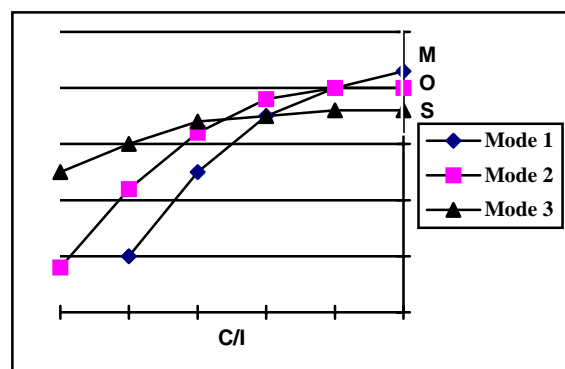

Fig. 5.2 - Family of curves showing performance for different codec modes

To achieve the expected improvements in terms of quality, the AMR concept is based on switching among modes to the aim of tracking always the best performance as a function of channel conditions. This corresponds, in principle, to have the codec operating in the mode whose performance is the highest for a given C/I value. Since *codec mode adaptation* may occur rapidly, *codec mode rate changes* must occur seamlessly, i.e. with no perceptible speech degradation.

Moreover, to account for failures of the control system, a minimum level of performance shall also be granted for any point of the family of curves. For this reason, assessment of performance must consider the whole family of curves as well as the performance under dynamic behavior. This implies that testing of the AMR codec will be more extensive than forEFR.

## 5.4. Rate adaptation

Two types of rate adaptation are needed; *channel mode* (i.e. handovers between FR and HR) and *codec mode* (i.e. source and channel bit-rates for a given *channel mode*). *Conventional handovers* can be performed independently of AMR operation.

### 5.4.1 Channel mode adaptation

The *channel mode* (FR or HR) is switched to achieve the optimum balance between speech quality and capacity enhancements. The up- and down- links shall use the same *channel mode*. The *channel mode* is selected by the network (probably the BSC) based on measurements of the quality of the up- and down-links. These measurements may be combinations of conventional RxLev and RxQual reports and additional data transmitted in-band in the traffic channel or via flag stealing techniques.

The *channel mode* control algorithm should limit the frequency of *AMR handovers* performed to minimize the associated speech degradation as well as potential problems with channel re-packing and A-ter sub-multiplexing.

### 5.4.2 Codec mode adaptation

The *codec mode bit-rate*, i.e. the bit-rate partitioning between the speech and channel coding for a given *channel mode* may be varied rapidly to track changes in the radio link and to account for specific input conditions (speech signal characteristics, acoustic environmental characteristics, etc.)

*Codec mode adaptation* will operate independently on the up- and down- links. It will be transparent to the channel allocation and operate independently of it. Control will depend mainly on measurements of the quality of the respective links. The radio link quality metrics currently available, RxQual and RxLev, may not be adequate for *codec mode adaptation* (e.g. because they do not provide a sufficiently good measure of the impact of the link quality on speech quality or they are not transmitted frequently enough). Therefore, a new metric(s) may be desirable in addition to the existing ones and may be transmitted in-band on the traffic channels.

While the control of the *channel mode adaptation* will be mandatory located in the network side, there are several options of where the *codec mode adaptation* control algorithm could be located, e.g.

- Uniquely from the network for both links;
- By the relevant receiving entity (i.e. the MS for the downlink and the BTS for the uplink).
- By the relevant transmitter based on reported measurements.

It is however assumed that the *codec mode* decision could be overridden by the network entity.

The three scenarios differ in terms of signaling capacity needs and in the delay introduced in the adaptation process.

The current working assumption is to locate the codec mode adaptation control in the network. With such assumption, it is most likely that the in-band signaling channels in uplink and downlink would be asymmetric. This implies that the amount of bit-rate devoted to channel coding of the speech information can be different in uplink and downlink, thus allowing the use of two different channel coding algorithms for the two links. In order to preserve TFO, the possible source coding modes, instead, shall be the same in uplink and downlink.

The maximum rate of adaptation will be determined by the in-band signaling data rate and the loop delay. Early analysis suggests that *codec mode rate* changes of several times a second can be supported. A further constraint to the maximum adaptation rate is given by the increase in the channel activity when operating in DTX mode (see section 5.6 for further details).

## 5.5 Support of TFO

For the same reasons as for the existing GSM codecs (improved mobile to mobile performance), TFO is required for AMR. The optimum solutions have yet to be determined at this stage, however, the feasibility aspects are considered in Section 6.4.1.

## 5.6 Support of DTX

The AMR codec shall support DTX operation. Therefore VAD algorithm and Comfort Noise generation algorithm are part of the specification of the AMR codec. However, the DTX algorithms are not required to be included in the proposals of candidates until after the selection phase.

While the DTX mechanism in today's GSM codecs is activated by the input signal content only, when considering the signaling needs of the AMR codec, it may be necessary transmit in-band signaling data even during periods where the channel could be switched off. This could imply an increase of the SID frame transmission rate when compared to the current situation. To limit the impact of such effect on the DTX gain, the increase of the radio channel activity in terms of average transmission power should not exceed [8 %].

## 5.7 Support of 8 and 16 kbit/s A-ter sub-multiplexing

The AMR codec shall support A-ter sub-multiplexing at 16 kbit/s. Sub-multiplexing at 8 kbit/s for HR channel mode is desirable but imposes a severe constraint on the maximum source bit-rate (in the range of 6.5 - 7.5 kbit/s) which could undermine the performance quality target matching. In addition, switching between codec modes of the AMR codec could imply rapid switching between 8 and 16 kbit/s sub-multiplexing that could be difficult to achieve and cause quality degradations. It is expected therefore that 8 kbps sub-multiplexing would only be used when a low HR codec rate is maintained for relatively long periods of time (e.g. 30 seconds or more).

A proposal was also received for a 6:1 multiplexing scheme, which could be applicable, when the majority of calls are AMR. This is for further study.

## 5.8. Active noise suppression

The possibility to include a noise suppresser in the AMR codec has been discussed. It was felt that a noise suppresser would improve the performance in background noise conditions of any candidate, especially in half rate mode. At the same time, it is essential to check the consistency of the improvement with multiple noise sources and noise levels, and to verify that the noise suppresser does not degrade the speech quality in clean speech conditions. These additional requirements would imply a dedicated test plan incompatible with the aggressive codec selection time frame.

As a consequence, in order to compare all solutions in the same conditions, and select the candidate with the best intrinsic quality, it was decided that noise suppressers would not be included during the qualification and selection phases, or that any noise suppresser integrated to a source codec should be turned off for these tests.

The selection and possible standardization of a noise suppresser will then be addressed in a separate phase in parallel with the definition of the VAD algorithm.

---

# 6. Feasibility issues

This Section discusses the main issues determining the feasibility of the AMR approach.

## 6.1. Codec performance

The original performance benchmarks set by SQSG for AMR are reproduced in Annex C. Several organizations ran extensive subjective tests of high performance codecs, representative of the types of codecs that would be submitted as candidates for AMR, to assess the feasibility of meeting these performance targets.

The possibility for AMR to provide robustness in error conditions by increased channel coding and hence lower rate speech coding on the one hand, and increased basic speech quality (higher source coding rate) at the expense of reduced error robustness on poor channels on the other hand, depends strongly on the channel error statistics.

It is anticipated that the performance gain of AMR under high error conditions will be significant under close to ideal frequency hopping situations, but that there will be no or marginal performance improvements under slow moving conditions without frequency hopping, due to the high frame erasure rates. Note that in this Section, figures of C/I (carrier to interference ratios) are referenced to the input to the channel equalizer. In GSM 05.05, a 2 dB implementation margin is assumed in the receive path so that a C/I of 7 dB at the channel equalizer corresponds to 9 dB at the antenna.

### 6.1.1. Basic, error and background noise performance

From the point of view of the envisaged applications for AMR (see Section 3.2.), the critical performance benchmarks can be reduced to the following:

#### Full-rate mode:

Clear (EP0)	EFR at EP0 *
EP3	EFR at EP1
Background noise (EP0)	Same as EFR

#### Half-rate mode:

Clear (EP0)	G.728
EP1	EFR at EP1
EP3	FR at EP3
Background noise at EP0	G.728

\* The definitions of EP0, EP1, EP2 and EP3 are given in Annex A under "Acronyms".

#### Full-rate mode

In full-rate mode, the main challenge is the EP3 performance and the tests so far performed indicate this target could be difficult to achieve, representing a small risk. EFR at EP0 can be met (cf. existing EFR codec) for which a codec bit rate approaching 12 kbps is likely to be necessary.

It is expected that the performance for lower rate codec modes in the presence of background noise will be noticeably lower than that of EFR (in clear conditions).

#### Half-rate mode

More challenging is the performance that is to be achieved in half-rate mode. The "wireline" criterion for HR mode was interpreted by SQSG as G.728 (similar to G.726 at 32 kbps used on DECT and CT2). The corresponding objective at EP1 was EFR EP1 performance. EP1 corresponds to a C/I of 10 dB at the channel equalizer input. Results from trial codecs have shown that this C/I figure is too low to achieve EFR EP1 performance because the speech codec bit rate needed for G.728 quality is likely to be close to 8.0 kbps, leaving very little room for channel protection. Test results on several different codecs have shown



that a more realistic target to reach EFR EP1 quality is a C/I threshold of 16 dB to 20dB. Similarly, the quality objective in HR mode at EP1 has been relaxed to FR at EP1.

This means that to maintain the quality target, a lesser proportion of calls will be in half-rate mode; alternatively with the same proportion of half-rate mode calls, the average quality will be degraded in half-rate mode. The implications are discussed further in Section 6.3.

The EP3 target can be met as evidenced by the existing GSM HR (5.6 kbps) codec.

The background noise performance in the half-rate channel mode is a critical AMR area. The background noise performance will be lower than in the full-rate channel mode. On examination, the background noise target of G.728 (the original objective for AMR in HR) was found in fact to be even higher than that of EFR. Neither G.728 nor EFR background noise performance is likely to be achieved at a data rate of around 8 kbps. It is recommended instead that the background noise requirement be relaxed to

“Better than both GSM FR and G.729”

The reason for choosing two references is that the GSM FR codec performs better with vehicle noise while G.729 performs better with street noise and babble.

In the presence of background noise, the channel error performance of the AMR half-rate code modes will be noticeably worse than without background noise. One result showed that GSM FR performance might be difficult to achieve around 10 dB.

### 6.1.2. Tandeming

The performance under tandeming conditions has not been measured. As a general rule, if good/excellent performance is being achieved under single codec conditions, then it is unlikely that a serious loss of quality will be encountered under tandeming of the AMR codecs, except possibly under background noise and error conditions. However, this is less evidently the case for mismatched codecs. The lack of data on tandeming performance therefore represents a small level of risk.

When AMR reaches a significant level of penetration, it is very likely that a large proportion of calls will be MS-to-MS. The management of the AMR by TFO is therefore important to minimize tandeming of codecs.

Furthermore the interoperability with any GSM codec (including the AMR) will have to be assessed.

### 6.1.3. Seamless codec mode bit-rate changes

Codec mode bit rate changes may occur rapidly (more than once a second) and it is required that the switching between codec modes (for the same channel mode) must occur without any audible impairment. Tests conducted by two organizations have shown that with appropriate care to the codec structure, this is achievable.

While the switching itself should not cause any audible glitches, the fact that the speech codec bit rates is changing will itself cause some change in speech quality which will be audible. However, the reason for changing codec mode will normally be a change of channel errors and the effect of *not* changing codec mode will be worse.

### 6.1.4. Complexity

The complexity of the AMR source and channel codecs is governed on the one hand by the need to meet the required performance levels and on the other, to allow AMR to be introduced at the lowest cost. To meet these needs, the following constraints have been agreed.

Considering

- that an increase of the channel codec complexity may not allow significant improvement of the speech quality,
- the high cost of BTS hardware upgrade,

the complexity requirement for

- the channel part of the AMR codec when in half-rate mode (including control loop management) is not to exceed the Half Rate channel codec complexity figure.

- the channel part of the AMR codec when in full-rate mode (including control loop management) is not to exceed twice that of the Half-rate channel codec complexity figure.

Considering

- that quality improvements could be achieved in the speech codec with an increase of the complexity figure,
- the DSP technology increase in the time frame of AMR introduction (during 1999),

the complexity limit for the speech part of the AMR codec (excluding VAD/DTX) is 8 times the complexity figure of the speech part of the Full Rate codec.

Nevertheless an AMR speech codec with a complexity figure less or equal than the existing codecs (EFR or HR) will present significant advantage. This will lead to a complete reuse of the existing platforms for both MS and TRAU.

#### Requirements summary

	Complexity requirement
Half-rate channel coder/decoder (including control loop management )	less than or equal to that of the HR channel codec
Full-rate channel coder/decoder (including control loop management )	less than or equal to twice that of the HR channel codec
Speech coder/decoder (excluding VAD/DTX)	less than or equal to 8 times the FR speech codec (excluding VAD/DTX)

Appropriate ways of measuring complexity for the purposes of codec test and selection have still to be determined.

## 6.2. Quality and Capacity benefits of AMR

AMR may be used in different ways in a system. The basic features of AMR are the higher robustness to low C/I conditions on full rate channels and the higher quality on half rate channels at high C/I levels. These basic features may be used in different ways to obtain higher quality or higher capacity

### 6.2.1 General AMR performance

A central principle of AMR is the ability to dynamically change the allocation of source and channel coding bits, in order to always provide the highest possible speech quality. The overall quality and capacity improvements with AMR are dependent on several factors:

- codec performance as a function of channel quality
- C/I distribution in the selected area, as well as actual C/I variations in calls
- precision and update frequency of the AMR control system
- System characteristics (type of FH, number of TRX's etc.)

a) The basic codec performance as a function of channel quality (e.g. C/I) provides an upper limit to the achievable quality by AMR. I.e. the envelope of the performance curves defines the best possible performance assuming perfect channel quality tracking. For FH systems and non-FH systems at high speeds different allocation of bits for the speech coder and for error protection gives a possibility for trading capacity and quality (see section 3.2). A crucial point is the estimation of channel quality, and the relation between channel quality measurements and speech quality. This has only partly been assessed. (See Section 6.3.3.)

b) In general there is a relatively large spread of C/I values, indicating that an AMR coder with adaptive allocation of speech and channel coding bits can provide higher quality or capacity by change of working point (bit allocation). The actual channel quality may however vary significantly between and within calls, and the possibility to accurately track the channel with sufficient resolution may limit the AMR gain. Limited

sets of measured data were made available, indicating very large variations within as well as between calls. The conclusion is that AMR needs to be very robust to a large span of channel variations.

c) Channel quality variations may be both rapid and large. In the design of the control system there is a trade-off between in-band channel information and speech coder bits. The performance of the channel tracking algorithm will also highly influence the AMR performance.

d) The specifics of the system, such as the use of different FH, the number of TRX's per cell, the efficiency of the power control if activated and particular frequency and cell planning strategies etc. will have an influence on the codec performance and the possible quality/capacity gains. The characteristics of specific networks have indeed a direct influence on the C/I statistical distribution, leading to potentially reduced spread of the C/I in "optimized" systems and hence potential lower additional gain brought by AMR.

## 6.2.2 Improved coverage from the improved robustness in FR mode

Under high channel errors, a FR codec mode will normally be selected which has a low source coding rate and a high level of error protection. This will allow good speech quality to be maintained under S/N conditions 6 dB worse than the corresponding level for EFR. This translates to an improvement in terminal or BTS sensitivity but is subject to the limit of robustness of the signaling channels [not estimated during the Study Phase]. This improvement in sensitivity is at least 2 dB and could be as high as 4 dB or 6 dB.

This extension may be exploited for improved coverage in marginal conditions such as in buildings or potentially for range extension. The latter would only apply to new networks where site spacing has still to be selected and where the great majority of terminals are AMR. Even then, there could be performance problems with terminals without AMR such as roamers and data terminals. This was not investigated.

## 6.2.3 Capacity benefits from the improved robustness in FR mode

The GSM system capacity is a direct function of the minimum acceptable C/I ratio for an expected Grade of Service (for example 99% of the cell area). The distribution of the C/I over a GSM network is in turn a function of the frequency re-use pattern, and directly related to the activation and performances of the radio features of the system, such as Slow FH, Power Control, DTX etc. The capacity also depends on the propagation conditions in the area of concern, such as shadowing characteristics, applicable propagation losses, antenna heights and apertures. Finally the actual performances of the infrastructure will generally impact the system capacity.

With AMR in full rate mode, the C/I threshold for an acceptable speech quality level may be reduced by 4 to 6 dB compared to the system operation with the current speech coders (FR, HR or EFR). This improvement will translate in the possibility to operate the system with a reduced re-use cluster, or with a higher traffic loading. For example a system operating in a 12-cell cluster could be upgraded to a 9-cell re-use cluster providing a direct 30% capacity increase.

This improvement is applicable if AMR is used in Full Rate mode at low C/I conditions or severe error conditions, i.e. for applications where AMR is used in Full Rate mode only or in both Half and Full rate modes according to the propagation conditions (application scenarios 1 and 3 of Annex B).

However, an improvement gained by a re-planning of existing systems should be considered with care as it does not apply to the GSM signaling channels, to the speech service when using speech coders other than AMR or to the data services, i.e. in networks with a mix of services where the penetration of AMR is limited.

## 6.2.4 Quality/capacity trade-offs by use of the HR mode

A number of simplified studies on the quality/capacity aspects have been made. It is generally agreed that there is a possibility for a trade-off between quality and capacity using AMR; Full Rate only (for maximum quality), half rate only (for maximum capacity) or a mix of full rate and half rate (in a similar manner as for the existing coders). The actual quality and capacity will however depend heavily on the system assumptions as well as the specific AMR solution. In particular, there are significant difficulties in estimating actual C/I distributions in systems. Two main approaches have been used to estimate the capacity gain, as described below.

### Estimated C/I distribution approach

In one approach the capacity increase has been estimated assuming the half rate channel mode can be used above a certain C/I threshold, where it provides G.728 quality. This threshold has been estimated at 16

dB - 20 dB using ideal FH. Capacity gain, assuming full penetration of AMR mobiles, was then derived from the instantaneous C/I distribution within the cell, by applying a "safety" margin on top of the previously discussed threshold. The C/I distribution used was a distribution used in earlier work on 14.4 kbps data, which includes the effects of shadowing. The safety margin has to count for all the effects not taken into account in such evaluation i.e. the channel quality estimation error, the variability of the channel quality, the channel adaptation control delay, the blocking of resources, imbalance in up- and down-link etc. With that approach the corresponding capacity increase has been *estimated to be 30% - 40%* using a C/I threshold of 18 dB and safety margin of 7 dB. It should be noted that the safety margin is an estimate.

Another estimation with different system assumptions using actual C/I distributions from a planning tool (for a particular dense area of the network) used by one operator have also been performed. The estimated C/I distribution in each cell was then used, as well as the traffic distribution and BTS configuration. In general, the C/I distribution obtained has a higher mean value than the above approach, which uses a "typical" C/I distribution. The higher mean value translates into a higher number of mobiles, which can use the HR channel mode at any given time, resulting in higher capacity gains. The study also indicated that there are clear differences in the calculated C/I distributions for different areas. Assuming satisfactory speech quality is obtained on the HR channel for C/I values exceeding 18 dB, and using a "safety" margin of 7 dB, the resulting capacity figures for 100% AMR penetration are in the range 80% up to 110% (trunking gain included) depending on the actual planning area. These results clearly indicate that the capacity gain for a certain quality is strongly dependent on the C/I distribution in the system.

### System simulator approach

An alternative approach uses a radio system simulator to estimate the quality and capacity. In this approach a representative family of codec performance curves are used to describe the speech quality of the different AMR codec modes depending on C/I. An AMR control system, which incorporates measurement errors as well as decision delays, is used to select codec modes and perform channel mode handovers.

Fig. 6.1 indicates the trade-off between relative capacity and "average" speech quality in a system, assuming 100% AMR penetration, with ideal FH and power control using 4 TRX's per cells.

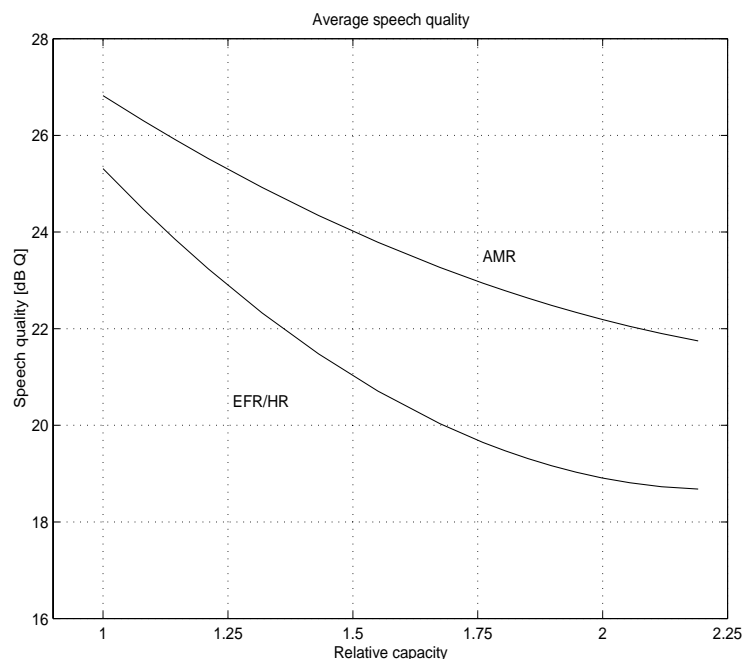

Fig. 6.1 - Average speech quality vs. relative capacity for AMR and EFR/HR

Speech quality is presented in equivalent dBQ. As a reference, the existing FR has a quality of approximately 22 dBQ under error free conditions. A comparison with a solution using the existing EFR and HR to gain capacity is included. The quality gain of AMR is approximately 3 dBQ. At a capacity increase of 85% for AMR, the average quality is approximately the same as for the EFR/HR system at a capacity increase of 25%. The average quality if only half rate channels are used is also noticeably increased for AMR due to the higher basic quality of AMR. If two TRX's are used the quality is lowered by approximately 1

dBQ and if six TRX's are used the quality is raised by approximately 1 dBQ, but the difference between AMR and EFR/HR remains.

Fig. 6.2 is similar to fig. 6.1, except instead of the average speech quality, the quality at a certain proportion of the speech quality distribution in the system is shown.

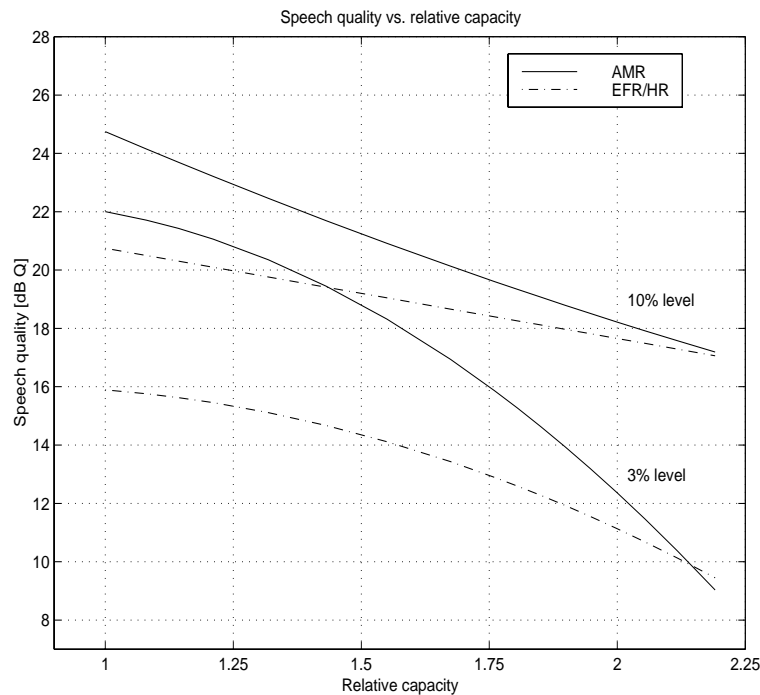

Fig. 6.2 - Speech quality for AMR and EFR/HR at the 3% and 10% levels

The 3% curve can be interpreted as the quality of the 3% of the calls (or parts of the calls) which have the worst quality in the system. If capacity increases are limited to approximately 70%, there is a significant increase in quality for the calls with the lowest quality due to the robust operation on the full-rate channel.

### 6.2.5 System aspects of capacity/quality

In the above section, the capacity gain was computed with a number of simplifying assumptions, given the difficulty to have a complete picture of the actual behavior of the system. Some of the following aspects have partly, or not, been modeled in the previously computed gain.

The re-packing of half rate and full rate channels on the air interface may potentially cause high system load as well as degradation due to intra-cell handovers. The results presented in the previous section do not require a sophisticated re-packing strategy. Results have also been presented indicating slightly higher gains if more sophisticated re-packing strategies are used.

It is desirable to limit the channel mode handovers to at most a few AMR handovers per 2-min. call. Results have been presented indicating that the quality/capacity degradation due to such limitations is small.

In connections where the quality of up- and down-links differ substantially, there is potentially a loss, since the two links are required to use the same channels (full-rate or half-rate). [Contributions needed]

A further impact on quality and capacity may be due to resource allocation constraints. Indeed among other aspects, the assumption that time-slots within a cell do not, on a short term basis, provide the same quality leads to the need to combine the channel mode adaptation and the resource allocation in order to avoid Ping-Pong between modes as explained in Section 6.3.6. This has a direct impact on the "re-packing efficiency" and hence on the expected capacity gain since mobiles cannot be simply moved onto any time-slot.

### 6.2.6 MS penetration

Studies on the impact of AMR penetration on capacity gain have been conducted following the approach of an estimated C/I distribution in section 6.2.3. The results presented in Fig. 6.3 gives an indication of capacity

gain depending on AMR penetration for different levels of the half rate C/I operating thresholds (including the “safety” margin described in section 6.2.4). The case when AMR is operated in HR mode only is also indicated. The results for 100% AMR penetration is consistent with 30%-40% capacity gain obtained with an aggregated C/I threshold of approximately 25dB.

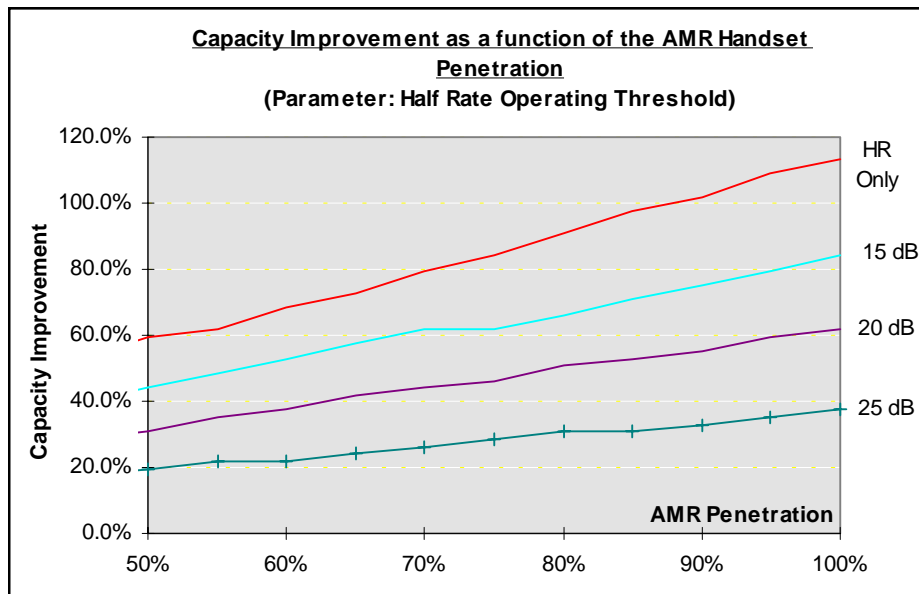

Figure 6.3 AMR capacity gain as a function of AMR penetration

## 6.3 Codec adaptation

The working assumptions for the mechanisms for codec adaptation are described in Section 5. Here, the feasibility aspects only are addressed.

### 6.3.1 Codec mode

The codec mode (bit-rate partitioning between the source and channel coding) should be changed rapidly to respond to the rapidly changing radio conditions. For this an accurate channel metric is needed and measurement reports should be reported frequently across the air-interface.

The schemes for doing this are assumed to be part of the proposals from the AMR candidates. Nonetheless, their feasibility should be assessed here.

Signaling data transmitted over the radio interface for codec mode control may include channel quality measurements, codec mode preferences from the MS, codec mode commands from the network and possibly other information depending on the specific proposal.

In the case of a very small amount of information, in principle the stealing flag bits can be used, otherwise a certain portion of the speech frame bits must be used.

How fast the update rate of such information should be, depends on the dynamic behavior of the channel conditions.

An update rate of 10 times a second (five times faster than that of the RxQual and RxLev reporting) should be adequate to maintain good quality in response to changing radio conditions. In practice, a fading margin of typically [3 dB - 6 dB] should be introduced to avoid quality variations (see Section 6.3.4). With this margin, consistent quality should be maintained although possibly at the expense of some loss of capacity enhancement (more channels forced to full-rate). The precise trade-off will not be known until AMR solutions are tested under realistic radio conditions. While this remains an issue for further study, it is not seen as a particular risk factor.

On the other hand, the actual transmission rate of the in-band side information depends on the protocol used to convey the information. This could imply spreading the information on subsequent frames to save transmission bits, but at the expense of an additional delay in the control loop. A constraint to the signaling rate is due to the DTX operation that switches off the transmitter. Although a frequent signaling of the side

information is an essential requirement for AMR operation, this has not to increase the channel activity such that to undermine the effectiveness of DTX.

The requirements of the channel metric itself are discussed in Section 6.3.3.

### 6.3.2 Channel mode

The execution of channel mode handovers should be identical to conventional intra-cell handovers although the algorithm for their initiation will be different. The frequency of such handovers should be restricted because of the quality degradation (due to frame stealing for signaling) and more significantly, the load on the BSC processor, associated signaling and possible consequential re-packing. Moreover, the channel mode selection algorithm should be integrated into the radio resource algorithm (see Section 6.3.6). The channel mode control will most likely be incorporated into the radio resource algorithm and the frequency of AMR handovers controlled by means of Hysteresis etc.

The impact of restricting handovers is that the quality in AMR HR mode could be impaired (since it could be operating outside its intended limits) or the capacity would be reduced, if in FR mode. It is not evident at this time how often handover restrictions would come into play nor how significant would be its impact on performance. Evaluations of a very limited range of actual calls using a simple channel mode algorithm (based on RxLev and RxQual) showed that many calls require no handovers while others require many. These results suggest that average handover rate could be doubled as a result of AMR operation and some calls may have fewer AMR handovers than ideal.

### 6.3.3 Channel metrics (accuracy, update rate)

The AMR link adaptation algorithm will be based on a channel metric, such a metric being representative of the speech quality as perceived by the user. It is anticipated that that metric will use the estimated residual error rate available from the output of the channel decoder and a number of other factors to assist in assessing the trend of the error rate. These may include the burst wise RxLev, the BFI and information from the equalizer but also system information such as DTX activation and frequency hopping activation. This information can be vector quantized to provide information of the position on a performance surface for the codec and the trend of channel quality, i.e. improving or degrading. The performance surface is created through characterizing the subjective quality of the codec as perceived by the customer against the residual error rate.

Inputs made to SMG-11 have shown how the different codec rates can be chosen according to an averaged residual error rate and deliver acceptable speech quality under simplifying assumptions.

The AMR codec will operate and be controlled over a wide range of C/I conditions. In full-rate mode, it will be possible to operate at very bad error conditions corresponding to C/I values worse than 4dB (at the channel equalizer). In half-rate mode, G.728 quality is only expected at C/I values in excess of [18 dB]. Best performance will only be achieved by selecting the codec mode matching the channel condition.

It is also critical that the metric is accurate since if the wrong codec mode is selected, the quality will be reduced undermining one of the basic principles of AMR.

It is assumed that the channel metric will form part of the candidate's solution.

### 6.3.4 Channel dynamics, effects on performance

As seen above (Section 6.4.1), the codec mode can be changed to track the radio signal dynamics with time constants as short as [100msec]. Assuming that the codec mode adaptation algorithm is based on a comparison between the channel metric and a set of thresholds, the decision thresholds should count the codec performance crossing point and allow for a "fading" margin. Such a margin should be chosen to take into account fast variations of the error rates and hence the correlation time of the channel dynamic to avoid Ping-Pong effects. On these time-scales, the signal dynamics are dominated by Rayleigh fading although under some fast moving conditions, shadow fading can also come into play as far as the useful signal is concerned, the same dynamic applying also to the interferers. Measurements and simulations of the radio channel suggest that a margin of [?? dB] should be allowed. The exact margins will have to be fine-tuned once AMR systems have been developed and operated in real radio environments.

The effect on performance of allowing for this margin is estimated in Section 6.3. [Check]

### 6.3.5 Location of codec mode and channel mode control

#### Channel mode

As the control of the AMR channel mode will have to be integrated with the Radio Resource algorithm, it is assumed that they will be co-located in the BSC or distributed between the BTS and BSC. This combined algorithm will use the existing channel measurement reports, RxLev and RxQual and the new channel metric yet to be defined.

#### Codec mode

Since the additional channel measurement reports for AMR will be transmitted in-band, there are several alternatives for the location of the codec mode control and the associated transmission of measurement reports and mode commands. These have been reviewed and the recommended approach is that

- Codec mode control relating to capacity or radio link quality should be located in the network (BSS)
- MS can autonomously select the codec mode of the up-link on the basis of speech source content (e.g. background noise); however, the network should have the option to e.g. override the MS preferred selection or restrict the range of selectable modes.

The first point is seen as important because it allows the flexibility to upgrade the control algorithms of both the up- and down- links retrospectively. However, this may imply an increase of the data to be exchanged between the MS and the BTS when compared to solutions where no metric-related data are exchanged. Advantages were also shown in using a scheme where the control is distributed between the MS and BSS. However, unless very clear advantages over the centralized approach are demonstrated, the centralized approach will become the firm requirement at the start of the development.

The reason for emphasizing source-controlled selection in the MS is that it is more difficult to achieve good quality with background noise, especially at low codec bit-rates. Selecting the codec mode locally at the MS allows good quality to be maintained with background noise, provided that the radio conditions allow a possible increase of the source bit-rate, without unnecessary reporting to the network. When operating in the HR channel mode, switching to the FR channel mode may be necessary to achieve good quality with background noise.

#### Transmission of measurement and control data

Channel quality information will need to be transmitted via an in-band signaling channel over-the-air with suitable protection (in the MS to BSS direction only for the centralized control). Such quality information can be assumed to represent an intermediate stage in the computation of the metric, obtained by processing of the in-band information and potentially other system parameters. It is believed that a good trade-off can be reached between the bit rate of the implied in-band signaling, including channel protection, and the speech coding bit rate.

As well as transmitting channel quality or control data in-band, it has also been proposed to use frame stealing flags. This would allow greater capacity on the radio interface for the transmission of speech data and channel protection.

### 6.3.6 Radio resource allocation

The existing resource allocation strategies applied to Full Rate (orEFR) codecs combined with the Half Rate codecs, or a fortiori Full rate only codecs, will have to be revisited with the introduction of the AMR, especially when handovers between Half Rate and Full Rate modes are allowed. Indeed, in contrast to the already difficult case of coexistence of Half Rate and Full Rate traffic channels, the channel mode can be modified during the call based on the channel quality estimates.

With AMR, the resource allocation strategy and the channel mode adaptation have to be coordinated such that the channel mode and the quality provided by the allocated resource are well paired. The objective is to reach the best trade-off between the carried traffic and the quality of the call.

Limitations will arise due to avoid Ping-Pong as well as too numerous channel mode changes (i.e. AMR handovers). Otherwise extensive use of layer 3 signaling will be required and this degrades the call (speech



interruption) in addition to loading up the BSC. An important side effect of these limitations is that it decreases the capacity gain from the AMR. It is currently difficult to evaluate this decrease as the exact effect will depend on the AMR handover algorithm which is manufacturer specific in a similar way to intra-cell handover.

## 6.4 Support of other features

### 6.4.1 TFO

One example of a tandem free configuration is shown in Fig. 6.4.

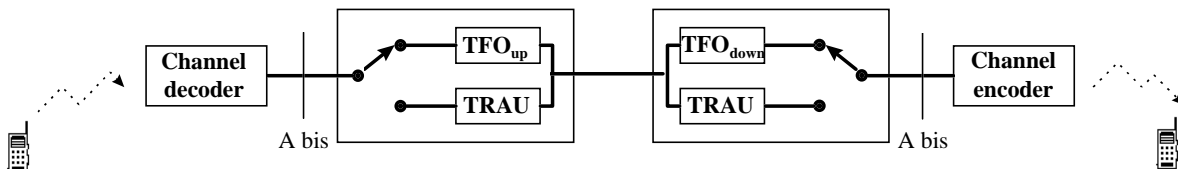

Fig. 6.4 - Mobile to mobile communication link.

TFO mode can be operated only if both mobile links in a mobile-to-mobile direction (e.g. up-link MS-A to network and downlink, network to MS-B) use the same speech coding bit-rate and algorithm. In principle this does not imply that the same *channel mode* has to be used, but can be achieved only if the AMR decoder is capable of operating at the same source rates for both FR and HR *channel modes*.

Several options are possible to deal with the TFO management when combined with AMR.

However, for AMR, the fact that the codec rates are varied, sometimes rapidly, presents special difficulties not previously encountered. Alternative approaches to this problem have been considered but the optimum method will demand detailed evaluation outside of the scope of the Study Phase.

Nevertheless it was identified that at least the BTS would have to be informed whether a call is TFO or not. In consequence provisions must be taken to convey such an information between the TRAU and the BTS.

Furthermore depending on the specific solution for the TFO scheme precautions may have to be taken in the basic AMR, e.g. the codec types designed for HR mode may have also to be adapted for the TCH/F.

Taking all these considerations into account, it is still felt that the implementation of TFO for AMR is feasible.

### 6.4.2 DTX

For the same reasons as for the other GSM codecs, AMR should support DTX for which VAD and comfort noise algorithms will be needed.

One concern is that if conventional DTX is invoked, the frequency of in-band channel measurement reports will be severely reduced. This could be offset by transmitting SID frames more frequently. This may also provide higher quality of the reproduced background noise. Different ways of implementing AMR DTX operation which retain most of the DTX gains are conceivable, possibly using lower transmission power.

How the channel measurements are to be reported during DTX will be at the discretion of the codec proponent. However, the restrictions and their significance need further evaluation.

This needs further study and currently represents a risk.

### 6.4.3 Power control

The availability of an accurate channel metric which is provided more frequently than RxLev could in principle allow power control to be exercised more precisely and rapidly than at present. This should enhance the advantages of reduced interference and longer battery life. However, it could also have the effect of reducing the C/I distribution (fewer calls at high C/I) and potentially constricting the range of operation of the AMR codec. This would reduce the capacity and quality gains of AMR operation.

A separate point is that there may also be interactions between a rapidly changing power control and codec modes. To counter this, there would be advantages to integrating the two into a common algorithm. In the

shorter term, there should not be any conflicts if the existing power control methods are combined with the short time constants of codec mode control.

This area requires further study but is only seen as a minor risk.

#### 6.4.4 Handover

In a similar way to power control, the new channel metric should also allow (conventional) handovers to be controlled more precisely since the metric will give a more accurate measure of channel quality and over a wider range of C/I than is possible with RxQual. This is only highlighted here as an advantage and has no bearing on the feasibility of AMR.

#### 6.4.5 8 and 16 kbit/s A-ter sub-multiplexing

##### a) Full-rate mode

The maximum source coding rate for full-rate mode (using 16 kbit sub-multiplexing) is about ?? kbps which is sufficient for the highest expected AMR rate even with the inclusion of some channel protection (as for EFR).

##### b) Half-rate mode

The existing HR codec can be transmitted on the A-ter interface using 8 kbps instead of 16 kbps sub-multiplexing thereby doubling transmission capacity. Operators see this as a useful feature and it is desirable that this is also available for HR mode of the AMR codec. This has been evaluated.

The maximum source coding rates that can be supported on the A-ter interface will depend on the precise data formatting and signaling schemes. According to the compromises selected, this rate is estimated to lie between 6.5 and 7.5 kbps, although the higher figure would require significant compromises in terms of backward compatibility with the existing TRAU frame formats leading to dedicated TRAU for AMR or new TRAU frames for existing codecs. Codec tests have also suggested that the bit-rates needed to achieve G.728 quality in HR mode is likely to be close to 8 kbps. This implies that to achieve the AMR target quality in HR mode, a sub-multiplexing rate higher than 8 kbps may be necessary.

A new proposal was discussed based on 6:1 multiplexing (instead of 4:1 or 8:1) which would support an 8 kbps source coding rate. However, this would be most applicable when most channels are AMR rather than a mixture of the other GSM codec types and is seen as a longer term solution. Nonetheless, it remains a potentially attractive solution. As the approach is new and raises a number of issues, it is recommended the approach be studied further.

In the shorter term, attention is focused on 8 kbps and 16 kbps sub-multiplexing [which can be mixed - *check*]. It is probable that there will have to be at least two codec modes at HR, one for high C/I (e.g. > 18 dB) and one for low C/I. Since codec mode changes can occur rapidly and switching between 8 kbps and 16 kbps sub-multiplexing will cause quality degradations, it is anticipated that a fixed sub-multiplexing rate will have to be used for HR mode. Therefore to support 8 sub-multiplexing, the HR codec mode may have to be restricted to the lower source coding rate in HR mode, significantly limiting the quality and value of AMR. Nonetheless, as some operators may need this flexibility under certain circumstances, it is recommended that at least one codec mode in HR is provided which supports 8 kbps sub-multiplexing.

Recommendation:

- No constraint applied on the upper limit of the source codec bit-rate in HR mode
- At least one source coding bit-rate in HR mode to be consistent with 8 kbps sub-multiplexing.
- Study potential for 6:1 or similar compression scheme as a longer term solution

### 6.5 Wideband service option

The feasibility of adding a special mode to AMR, which would support a wideband speech service (e.g. 7kHz), has been assessed but many aspects have not been resolved due to lack of time. The broad question of whether to add a wideband mode to AMR was the subject of considerable discussion but there were conflicting options. Nonetheless, there is agreement that the AMR program should not be delayed for

the sake of introducing a wideband mode. The issues are summarized in a separate liaison statement to SMG in which SMG are requested to decide how the development of a wideband service should proceed.

Some of the main points are identified below

- A wideband service would give a substantial quality uplift over narrowband and there is foreseen to be a market for mobile-to-mobile wideband users (or mobile-to-fixed), although the service will initially be restricted by the number of users having the necessary wideband terminals.
- Noting the need to avoid the proliferation of GSM codec standards, including wideband on AMR gives the best opportunity to deliver a wideband capability in the near term.
- A wideband mode may be accommodated within the Release '98 AMR development program by only testing it in the Qualification Phase and then giving preference to AMR candidates, which include a wideband option, which meets the performance specification. The wideband mode would be given lower priority than narrowband. This approach has not yet been agreed by SMG11 as workable and needs to be reviewed and elaborated.
- There are also serious concerns that adding wideband to narrowband AMR adds risk to the program due to the additional testing and selection tasks and reduces the chances of meeting the Release '98 deadline.
- It has not been established that the wideband performance capability achievable with a single TDMA timeslot (i.e. 13 kbps approx.) will be adequate for a commercially competitive wideband service. This is substantiated by the recent failure of any of the candidates to meet the performance targets for an ITU-T 16kbps wideband speech codec under certain conditions.
- There exist examples of wideband speech codecs with bit-rates in the range 12 kbps to 13 kbps, which show promising performance.

---

## 7. Requirements specification

The target performance requirements for the AMR codec was set out in the report SQSG presented to SMG#20 in October 1996 (see Tdoc SMG 447/96). These requirements have been reviewed and in the light of feasibility assessments made during the Study Phase (see Section 6.1.1.), a revised requirement specification has been produced (see Annex C). This is more complete and precise to enable the candidate codecs to be properly developed, tested and selected. Some of the targets have also been modified in the light of assessments of the performance that can practically be achieved. These concern mainly the performance in HR mode under medium error conditions and the performance in the presence of background noise.

Time has not allowed the requirements to be defined and agreed in respect of the performance under dynamic conditions. This work is in progress but is not ready to be approved. These requirements will have to be approved by SMG11 and frozen for the start of the Qualification Phase in November '97.

---

## 8. Implementation factors

The main logical entities in the network and MS that will need to be upgraded to support AMR are identified in Annex D.

The costs of implementation of the upgrades to existing networks will depend on particular manufacturer's implementations and no attempt has been made to estimate them here.

---

## 9. Codec development and selection

### 9.1 Test and selection methodologies

The candidate AMR codecs will be tested by a combination of static and dynamic tests. For the static tests, conventional, well-established methods will be used to evaluate each of the codec modes in clear, error conditions, with and without background noise under specific, static radio conditions (including Rayleigh fading, excluding shadow fading). In addition, the effects of switching between codec modes (for a given channel mode) will be tested by forcing rapid codec mode changes.

The dynamic tests in contrast will require completely new test methodologies. The purpose of these tests is to evaluate the performance of complete AMR system, including the codec adaptation system, in response to dynamic radio conditions. This requires a system simulator (see Section 9.3.) and error patterns corresponding to a widely varying radio path. These tests will evaluate the performance of codec mode adaptation in the absence of channel mode changes. New subjective test procedures will also be necessary evaluate and score the performance. The reference condition for such tests will be existing codec standards.

The dynamic test methodology and the system simulator is in the process of being formulated.

### 9.2 Asymmetry of up and down links

The test methodology for static and dynamic testing needs to recognize the asymmetry of the in-band signaling in the uplink and downlink and the recommended approach is outlined below.

#### Assumptions

It is assumed that for a given codec mode, the algorithm and bit rate of the speech codec will be identical for the uplink and downlink (note that this does not imply that the uplink and downlink must operate in the same mode simultaneously).

#### Static tests

If, for a given mode, there is a difference in the net channel coding rate of the speech between the uplink and downlink (i.e. after taking in-band signaling bits into account), the link with the least protected speech bits will be tested.

In static tests involving bit errors and mode switching, the channel coding will be included in the speech processing stages. However, the impact of bit errors in the signaling channel will be ignored; the codec mode will be determined only by the experimental condition, i.e. it will be fixed or switched at a pre-determined rate.

#### Dynamic tests

In dynamic tests, each experimental condition will be tested for both the uplink and downlink directions. The signaling system used for mode adaptation will be included in the speech processing stages, with the effect of bit-errors on the signaling bits incorporated. If signaling bits are external to the traffic channel, e.g. frame stealing flags, the effect of errors in these bits must also be simulated.

### 9.3 Speech traffic channel simulation model

Due to the need to take into account the adaptation concept of AMR, the traffic channel simulation model for AMR has to consider both transmission links simultaneously. The high-level block diagram of such simulator is reported in Fig. 9.1 referring to uplink configuration.

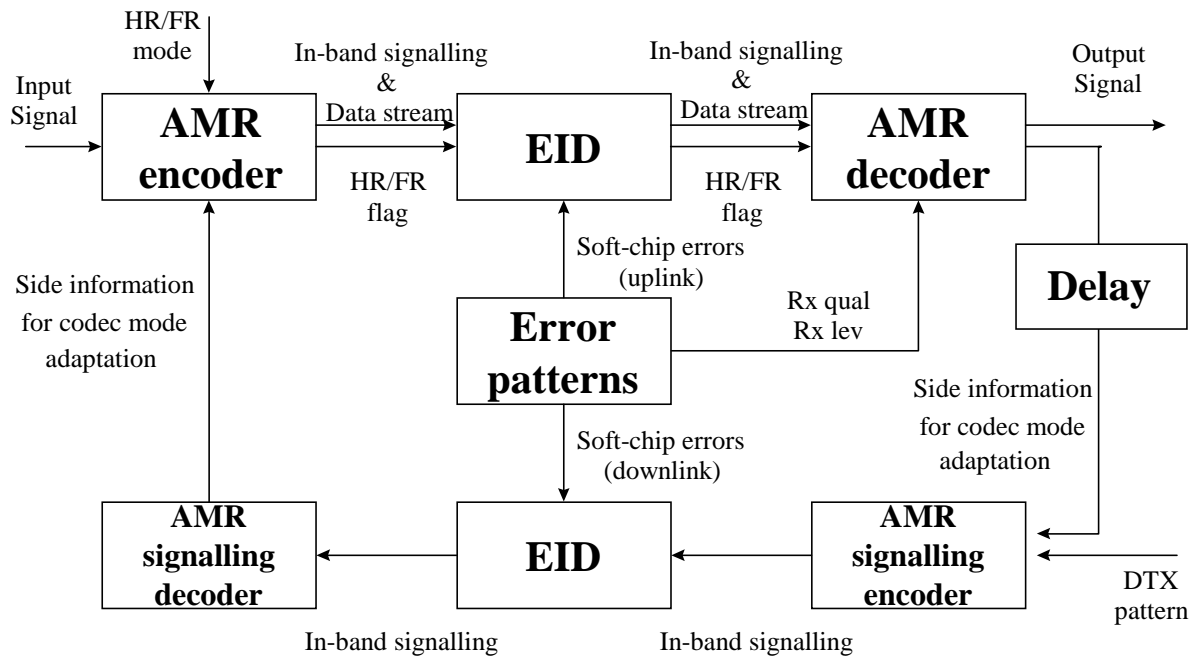

Fig. 9.1 - Block diagram of the AMR speech traffic channel simulation model.

The error patterns are assumed to carry also the information on RxQual and RxLev. The backward channel (downlink in this case) is used to take into account the effect of delay and channel errors on the in-band signaling data that are used to take decision on the codec mode bit-rate. The HR/FR channel mode flag is used to simulate AMR handovers. It is also used in the EID to select the proper error pattern.

Details of the definition of the various blocks as well as specification of interfaces are reported in Annex E.

## 9.4 Schedule

In response to the terms of reference of the AMR project, SMG11 and SMG2 have assessed the feasibility of a schedule that would deliver the AMR specifications in time for Release '98. The schedule has to include the following main activities:

- pre-qualification phase: Performance requirements, test plans, static and dynamic error patterns, system simulator specification, design constraints
- qualification phase testing
- optimization
- selection testing
- production of specifications followed by period of stabilization

A draft schedule for the AMR codec testing, selection and standardization is shown in Annex F. This incorporates the standardization of the associated control system and signaling. This schedule is itself very aggressive. Since it was produced, SMG2 have indicated that more time will be needed to produce the error patterns which are not expected to be available until December '97 (static patterns) and March '98 (dynamic patterns). The schedule therefore needs to be reviewed urgently and at the time of writing, it is not clear that Release '98 can be achieved.

Since a Release '98 schedule will carry a high degree of risk, the Qualification Phase of testing includes dynamic as well as static tests to reveal at the conclusion of this phase [March '98] the extent to which the candidate solutions meet the performance requirements. If they pass or come close, the selection phase will proceed (possibly with a short optimization phase). Otherwise, time will be allowed for an extended optimization period in which case, AMR would probably be postponed to Release '99.

## 9.5 Programme management

Prime responsibility for the AMR development will be held by SMG11 with SMG2 and SMG3 having secondary responsibilities.

The proposed Work Item description is contained in Annex G.

---

## 10. Open issues and risks

The feasibility study has evaluated to a greater or lesser degree the main aspects of the function and operation of the AMR codec. Preliminary evaluations as well as some advanced codec developments and testing have shown to a satisfactory level of confidence that the performance requirements are achievable. However, there remain a few areas that present some risks to the successful realization and application of AMR.

Issue	Impact on AMR performance	Risk levels assessed by SMG2 and SMG11	Risk assessment.
Speech quality	The performance requirements in HR mode under error and background noise conditions have been relaxed to be realistic.	Medium	The benefits are still significant even with the relaxation.
Channel and mode adaptation algorithms	The effectiveness of these algorithms is crucial to good AMR operation. Initial implementations may not realize the full potential of AMR. (Cf. handover algorithms).	Medium	Performance will improve with experience with real networks.
Impact of actual C/I distribution on capacity/quality benefits	Performance will depend on the actual C/I distribution. This has proved to be difficult to estimate reliably and the C/I forecasts produced so far have shown wide variations.	Medium	The main performance benefits (see Section 6.2.2.) have been estimated on the basis of the lower (i.e. more pessimistic) C/I distributions.

Provision of accurate channel metric over wide C/I range	If accuracy falls below the target, the non-optimum codec mode may be selected, significantly reducing the quality and capacity benefits.	SMG2: high  SMG11: medium	Proposals for the complete control mechanism including the channel metric have shown that viable solutions can be achieved.
Tracking of rapid signal dynamics by control system	This has been estimated but its impact cannot be properly assessed until sophisticated simulation tools or trial results become available.	SMG2: medium  SMG11: low	If the estimates have been optimistic, an additional safety margin should be allowed for.
TFO	Finding an effective TFO solution for AMR may require significant effort.	Medium.	Effective solutions will demand detailed investigations. Although highly desirable, AMR can operate without TFO.
Novelty and complexity of AMR	The AMR concept is introducing new methods not previously attempted.	Medium	The novelty of these techniques is also the reason for the advantages of AMR. Without the additional complexity, the advantages would not be realized.

---

## 11. Recommendations

On basis of the performance benefits and risks highlighted above, the following recommendations are submitted to SMG for approval:

- Initiate a program to develop, test, select and specify AMR speech and channel codecs together with related features such as VAD, DTX and comfort noise generation. The associated control, signaling procedures and TFO should also be developed and specified.
- An acceptable and workable time-plan should be agreed by SMG11 and SMG2 as soon as possible after SMG#23 with the priority of meeting Release '98 deadlines.
- Approve the performance requirement specification in Annex C.
- decide on whether a wideband mode should be included in AMR (see separate liaison statement)
- Approve the allocation of 400 kECU for the purposes of codec testing.
- Approve the Work Item Description contained in Annex G.

---

## Annex A Terminology

The terminology used in this document and recommended for other work on AMR is listed below.

<b>Adaptive Multi-Rate (AMR) codec</b>	Speech and channel codec capable of operating at gross bit-rates of 11.4 kbps (" <i>half-rate</i> ") and 22.8 kbps (" <i>full-rate</i> "). In addition, the codec may operate at various combinations of speech and channel coding ( <i>codec mode</i> ) bit-rates for each <i>channel mode</i> .
<b>AMR handover</b>	Handover between the <i>FR</i> and <i>HR channel modes</i> to optimize AMR operation.
<b>Bit-rate change</b>	Change of the <i>codec mode</i> bit-rates for a given (HR/FR) <i>channel mode</i> .
<b>Channel mode</b>	Half-rate or full-rate operation
<b>Channel mode adaptation</b>	The control and selection of the (FR or HR) <i>channel mode</i> .
<b>Channel Re-packing</b>	Re-packing of HR (and FR) radio channels of a given radio cell to achieve higher capacity within the cell. Controlled by in-band signaling (future) or out-of-band signaling (today). May influence the A-bis / A-ter interface.
<b>Codec mode</b>	For a given <i>channel mode</i> , the bit partitioning between the speech and channel codecs.
<b>Codec mode adaptation</b>	The control and selection of the <i>codec mode</i> bit-rates. Normally, implies no change to the <i>channel mode</i> .
<b>Conventional handover</b>	Inter- or intra- cell handover performed for non-speech coding reasons.
<b>Embedded Speech Codecs</b>	Family of speech codecs based on a "Core Codec" where the next "higher" codec fully includes (embeds) the next "lower" codec. Decoding of a "lower" codec mode is always possible without loss in quality below the quality of that lower codec mode. As a consequence higher codec modes can always be "stripped off" to lower codec modes on the way from encoder to decoder.  Embedded Speech Codecs are naturally rate compatible.
<b>Error Patterns</b>	Result of offline simulations (or measurements?) stored on files. To be used by the "Error Insertion Device" to model the radio transmission from the output of the channel decoder and interleaver to the input of the deinterleaver and channel decoder.
<b>Error Insertion Device</b>	
<b>Error Profiles</b>	Error Patterns plus additional information like RXQual, RxLev etc.
<b>Full-rate (FR)</b>	Full-rate channel or <i>channel mode</i>
<b>Gross bit-rate</b>	The bit-rate of the <i>channel mode</i> selected (22.8 kbps or 11.4 kbps).
<b>Half-rate (HR)</b>	Half-rate channel or <i>channel mode</i>
<b>In-Band Signaling</b>	Signaling for DTX, Link Control, Channel and codec mode modification, etc. carried within the traffic channel by reserving or stealing bits normally used for speech transmission. Maybe



	on the radio channel or other channels inside the fixed network (e.g. A-bis, A-ter, A).
<b>ISDN Quality</b>	Speech quality achieved on wireline telephones with a full duplex transparent digital connection over 64 kbit/s links.
<b>Out-of-Band Signaling</b>	Signaling on the GSM control channels to support link control. May be on the radio channel or other channels inside the fixed network (e.g. A-bis, A-ter, A).  Note: Out-Of-Band Signaling on the radio channel sometimes "steals" capacity from the speech traffic channel (FACCH) thus creating speech distortion.
<b>Rate compatible speech codecs</b>	Speech codecs (typically belonging to a family) which can be modified in net bit rate (typically on a frame by frame basis) without speech quality degradation below the quality of the worst mode.
<b>RXLEV</b>	GSM defined Receive Carrier Level Estimates, averaged over 480 ms
<b>RXQual</b>	GSM defined Receive Quality Estimates, averaged over 480 ms
<b>Speech Codec Family</b>	All speech coding algorithms which belong to an algorithm family.  Typically they have common architectures and can share program code.
<b>Toll Quality</b>	Speech quality normally achieved on modern wireline telephones.  Synonym with "ISDN quality" in most western countries.
<b>Wireline quality</b>	Speech quality provided by modern wireline networks. Normally taken to imply quality at least as good as that of 32kbs G.726 or G.728 codecs.

**Acronyms**

ACR	Absolute Category Rating
AMR	Adaptive Multi-Rate
C/I	Carrier-to-Interferer ratio
CNI	Comfort Noise Insertion
DCR	Degradation Category Rating
DSP	Digital Signal Processor
DTMF	Dual Tone Multi Frequency
DTX	Discontinuous Transmission for power consumption and interference reduction
EFR	Enhanced Full Rate
EID	Error Insertion Device
ETSI	European Telecommunications Standards Institute
FR	Full-rate
FH	Frequency Hopping
G.726	ITU 16kbs/24kbs/32kbs ADPCM codec
G.728	ITU 16kbs LD-CELP codec
GSM	Global System for Mobile communications
HR	Half-rate
IRS	Intermediate Reference System, No IRS= rather flat
ITU-T	International Telecommunication Union - Telecommunications Standardization Sector
MNRU	Modulated Noise Reference Unit
MOS	Mean Opinion Score
MS	Mobile Station
OVL	Overload point
PCM	Pulse Code Modulation
Q	Speech-to-speech correlated noise power ratio in dB
qdu	quantization distortion unit
RPE-LTP	Regular Pulse Excited codec with Long Term Prediction
SID	Silence Descriptor
SMG	Special Mobile Group
SNR	Signal to Noise Ratio
TCH-HS	Traffic CHannel Half rate Speech
TCH-FS	Traffic CHannel Full rate Speech
TDMA	Time Division Multiple Access
TFO	Tandem Free Operation
UPCM	Uniform or Linear PCM
VAD	Voice Activity Detector

**Error Patterns (EP0, EP1, EP2 and EP3):**

- EP0 without channel errors;
- EP1 C/I=10 dB; 5 % Gross BER (well inside a cell); TU3, Ideal Frequency Hopping
- EP2 C/I= 7 dB; 8 % Gross BER (at a cell boundary);
- EP3 C/I= 4 dB; 13 % Gross BER (outside a cell).

---

## Annex B Application scenarios.

With the intrinsic flexibility of the AMR system, it will be possible to customize the application of the codec to meet specific network and service needs. Some of the potential application scenarios are identified below (in no particular order) together with the advantages offered and the types of networks to which they may be suited.

### 1) Full-rate only; High quality over full range of channel errors.

This provides improved resilience to errors compared to GSM EFR so that when in call, the speech quality varies little with channel errors. It also provides significantly improved quality under marginal coverage conditions (e.g. at cell edge, coverage holes etc.).

Some capacity advantage may also be derived from the improved resilience under low C/I conditions. May support tighter frequency re-use.

Potential service applications: suitable for operators who do not need to increase capacity through half-rate operation but wish to offer the best speech quality possible to all users.

### 2) Half-rate only; Improved quality over current HR codec.

To gain maximum capacity advantage, the AMR codec can be operated in half-rate channel mode only. In this case, the AMR codec is likely to provide significant improvements in speech quality over the existing HR codec under low error conditions by using codec mode adaptation. Other improvements under background noise and tandeming conditions can also be expected.

Potential service applications: suitable for operators who need the greatest capacity enhancement from half-rate operation, but who are also seeking quality improvements. Some loss of quality at high channel error rates and in background noise can be expected (but still better than the existing HR codec).

### 3) Full- and Half-rate operation; simple HR/FR handover.

In this case, handover between FR and HR channel modes will be supported but probably only using the current intra-cell HR/FR handover capabilities. Such handovers would not be expected to be frequent (e.g. less than [5] in a two-minute call). *[Check]*

*AMR handover* will be controlled according to whether greatest emphasis is to be placed on quality or capacity enhancements.

This will allow combined quality and capacity enhancements but the simple handover mechanisms may lead to some short-term variation of speech quality as the variations of the error rate on the half-rate channel may not be tracked sufficiently rapidly.

Potential service applications: suitable for operators who want to combine speech quality and capacity improvements (less than that achievable through half-rate only operation).

### 4) Full- and Half-rate operation; advanced HR/FR handover.

In this case, an advanced handover scheme between FR and HR channel modes would operate. This may involve more handovers and the aim would be to "fine-tune" the selection of the FR and HR channel modes to obtain the best balance between capacity and quality. This may involve more handovers than 3) but as handovers themselves are a source of quality degradation, their number will still need to be restricted.

The particular FR/HR algorithm (on the BSC) may be customized to meet the operator's specific needs.

Subject to establishing the feasibility of this approach, this mode of operation should provide consistent high speech quality subject to only small variations in quality and an increase in capacity. The level of capacity improvement will depend on the FR/HR handover algorithm implemented.

Potential service applications: suitable for operators who want to combine speech quality and capacity improvements (less than that achievable through half-rate only operation).

---

## Annex C      Codec requirement specification.

### C.1      Static conditions

This Annex presents performance requirements and objectives for the speech quality of the GSM AMR system under static test conditions.

The half-rate and full-rate channels will be assessed separately. For each channel the speech quality of the codec modes associated with that channel will be assessed over a range of C/I and background noise conditions to provide a 'family' of performance curves.

Separate requirements and objectives are specified for clean speech and background noise. The type of the background noise, e.g. babble or vehicle, and signal-to-noise ratio (SNR) are specified in the associated subjective test plan.

The requirements and objectives for the full-rate and half-rate traffic channels under static test conditions are specified in Table 1. The following notes apply:

Note 1: 'Ideal case performance' assumes that optimum mode selection has occurred for the given channel, and is defined as the performance of the codec mode which provides the *best* subjective performance under the specified C/I and background noise condition.

Note 2: 'Worst case performance' assumes that the mode selection algorithm has made the poorest choice for the given channel, and is defined as the performance of the codec mode which provides the *worst* subjective performance under the specified C/I and background noise condition.

Note 3: Unless otherwise stated, the requirement shall be assumed to be 'not worse than'. In the case where two reference codecs are specified, the candidate codec must meet the stated requirement for both reference codecs.

Note 4: The 'not worse than' and 'better than' requirements will be interpreted statistically at the 95% confidence levels.

C/I	Full-Rate Channel		Half-Rate Channel	
	Ideal case performance (requirement)	Worst case performance (objective)	Ideal case performance (requirement)	Worst case performance (objective)
no errors	EFR no errors	G.728 no errors	G.728 no errors	FR no errors
19 dB	EFR no errors	G.728 no errors	G.728 no errors	FR no errors
16 dB	EFR no errors	G.728 no errors	G.728 no errors	FR at 10 dB
13 dB	EFR no errors	G.728 no errors	FR at 13 dB	FR at 7 dB
10 dB	G.728 no errors	EFR at 10 dB	FR at 10 dB	FR at 4 dB
7 dB	G.728 no errors	EFR at 7 dB	FR at 7 dB	
4 dB	EFR at 10 dB	EFR at 4 dB	FR at 4 dB	

Table 1a: Clean speech requirements and objectives under static test conditions.

C/I	Full-Rate Channel		Half-Rate Channel	
	Ideal case performance (requirement)	Worst case performance (objective)	Ideal case performance (requirement)	Worst case performance (objective)
no errors	EFR no errors	G.729 and FR no errors	better than G.729 and FR no errors	G.729 and FR no errors
19 dB	EFR no errors	G.729 and FR no errors	better than G.729 and FR no errors	G.729 and FR no errors
16 dB	EFR no errors	G.729 and FR no errors	better than G.729 and FR no errors	FR at 10 dB
13 dB	EFR no errors	G.729 and FR no errors	FR at 13 dB	FR at 7 dB
10 dB	G.729 and FR no errors	FR at 10 dB	FR at 10 dB	FR at 4 dB
7 dB	G.729 and FR no errors	FR at 7 dB	FR at 7 dB	
4 dB	FR at 10 dB	FR at 4 dB	FR at 4 dB	

Table 1b: Background noise requirements and objectives under static test conditions:

### Original SQSG performance benchmarks

The performance benchmarks originally set by SQSG for AMR are reproduced below.

#### Full-rate mode

Speech quality, talker dependency, background noise<sup>1</sup> and tandeming:

EP0	EFR under EP0
EP3	EFR under EP1

#### Half-rate mode

Speech quality, talker dependency, background noise and tandeming:

EP0	G.728
EP1	EFR under EP1
EP2	FR under EP2
EP3	FR under EP3

Complexity target for speech no higher than 8 times the complexity and channel codecs combined of the TCH-FS speech and channel codecs

Other points that need to be checked for adaptability:

- Varying channel condition test to ensure that channel adaptive technique does not seriously degrade performance including when DTX is operated.
- The ability for the coder to signal its need to be handed over to FR
- No annoying artifacts when changing channel modes.

Notes:

- 1) The background noise specification should recognize realistic usage environments and the expected minimum noise differentiation performance (DELSM) of the MS.

## C.2 Dynamic conditions

*[In the process of being defined.]*

## Annex D AMR implementation requirements

### D.1 Network

The following table lists the basic network functions, which would be impacted by the introduction of AMR. The table also identifies whether a similar modification was required for the introduction of EFR.

Device	Upgrade for AMR
BTS	New Channel Codec, In-band Transmission of metrics and signaling data, Codec mode adaptation algorithm based on the characteristics of the radio channel, DTX, New TRAU frames, <i>Transmission to the BSC of information related to the quality of the radio channel.</i>
BSC	Radio resource algorithm to incorporate channel mode adaptation and enhanced channel re-packing
TRAU	New TRAU frames, New Speech Codec, Codec mode adaptation algorithm based on the characteristics of the input signal, <i>G.722 may be needed in case of wideband codec</i>
MSC	Minor signaling extensions for e.g. handover, circuit pooling  <i>In case of wideband extension of the ISUP might be necessary to identify that wideband can be used in both terminals.</i>
OMC-R	Configuration of the AMR codec (e.g. TCH/H only)

Table D.1: Overview of the network modifications

The modifications in the network required for introducing the AMR will be dependent on the level of actual adaptation desired. As a matter of fact the AMR is a toolbox and thus does not oblige to implement all the features. This specific aspect allows a smooth introduction of the AMR in the sense that it can be done in several steps.

A general comment is that much more functions of the network have to be modified. An attempt of listing the functions to be modified is provided in table YY. Hardware upgrades may be necessary especially for the first generation devices (BTS, BSC and TRAU).

The OMC will have also to be modified if the operators want to take advantage of the high flexibility offered by the AMR.

<b>Generic Function</b>	<b>Upgrade Required</b>	<b>Equivalent upgrade required for EFR</b>
<i>Speech Frame Coding</i>	Support of the multiple Half Rate and Full Rate Speech Codecs Support of embedded In Band signaling	Only one new speech codec required for EFR
<i>Voice Activity Detection</i>	Support of a new VAD algorithm(s) for the half rate and full rate modes of AMR	Only one new VAD algorithm for EFR
<i>Ater</i>	New TRAU frames 8 and 16 kbit/s sub-multiplexing Increase of transmission means	New TRAU frames 16 kbit/s sub-multiplexing
<i>Codec Selection</i>	Processing of the RX In band signaling Support of a dynamic codec selection on a frame basis based on the RX In Band signaling and possibly on the characteristics of the source signal	Support of codec selection at call set up (Bearer Capabilities)
<i>Channel Coding</i>	Support of new channel coding for each codec	Same channel coding as the FR
<i>Interleaving</i>	Possible new interleaving schemes for some or all channel modes of AMR	Same as for the FR
<i>Stealing flag</i>	Possible extension of the stealing flag use to indicate the channel mode and/or carry some in band signaling	No modification of the stealing flag for the EFR
<i>Channel Measurement</i>	Support of a new metric for an accurate evaluation of the propagation conditions	No additional channel measurements for the EFR
<i>Stealing Flag Extraction</i>	Possible exploitation of the stealing to determine the channel mode and/or recover some in-band signaling	Not needed
<i>De-Interleaving</i>	Possible new De-interleaving schemes for some or all channel modes of AMR	Not needed
<i>Channel Decoding</i>	Support of a new channel decoding mode for each codec	Minor modifications of the TCH-FS channel decoder
<i>Speech Decoding</i> <i>Bad Frame Handling</i> <i>In Band Signaling</i>	Support of a set of new speech decoding algorithms for the full rate and half rate modes of AMR Possible new bad frame handling algorithms Extraction of the In Band signaling	Only one new speech decoding algorithm for EFR. New bad frame handling needed for EFR.
<i>TX In Band signaling</i>	Generation of an In Band signaling message containing either measurement reports and/or downlink codec requirement and/or indication.	Not needed



<b>Generic Function</b>	<b>Upgrade Required</b>	<b>Equivalent upgrade required for EFR</b>
<i>Resource Management</i>	Possible impacted messages/procedures include: Measurement Reports (to partially report the new metric on the SACCH)  System Information (to define the operation thresholds of the channel adaptation).  Channel re-packing must be implemented to achieve significant capacity gains.	Optimization of existing procedure
<i>Call Control Layer 3</i>	Codec negotiation/selection at call set up (Bearer Capabilities)  Channel Mode indication in Assignment/Handover Command	Codec indication at call set up (Bearer Capabilities)  Channel Mode indication in Assignment/Handover Commands
<i>Channel Mode adaptation</i>	The BSC manages the channel mode adaptation based on information received from the BTS.  More layer 3 messages per call. Processing power must be increased to maintain the number of Erlang managed by a BSC.	Not needed
<i>Power Control</i>	The Power Control may have to be modified in order to ensure a good coexistence with the Adaptation feature of the AMR (Ping-Pong effects must be avoided).	Not needed
<i>OMC</i>	Configuration of the operation mode of the AMR	Not needed
<i>Abis</i>	Increase of the LAPD transmission capacity	Not needed

Table D.2.: Detailed list of network modifications

## D.2 MS

The following table lists the basic Mobile Station functions, which would be impacted by the introduction of AMR. The table also identifies whether a similar modification was required for the introduction of EFR. Note that it is assumed that the management of half rate channels is already supported by the MS and does not require any upgrade as a result of the introduction of AMR.

The figure below presents a simplified architecture of a Mobile Station. The new functions or functions requiring an upgrade are framed by a double line.

<b>Generic Function</b>	<b>Upgrade Required</b>	<b>Equivalent upgrade required for EFR</b>
<i>Speech Frame Coding</i>	Support of the multiple Half Rate and Full Rate Speech Codecs Support of embedded In Band signaling	Only one new speech codec required for EFR
<i>Voice Activity Detection</i>	Support of a new VAD algorithm(s) for the half rate and full rate modes of AMR	Only one new VAD algorithm for EFR
<i>Codec Selection</i>	Processing of the RX In band signaling Support of a dynamic codec selection on a frame basis based on the RX In Band signaling and possibly on the characteristics of the source signal	Support of codec selection at call set up (Bearer Capabilities)
<i>Channel Coding</i>	Support of new channel coding for each codec	
<i>Interleaving</i>	Possible new interleaving schemes for some or all channel modes of AMR	
<i>Stealing flag</i>	Possible extension of the stealing flag use to indicate the channel mode and/or carry some in band signaling	
<i>Channel Measurement</i>	Support of a new metric for an accurate evaluation of the propagation conditions	
<i>Stealing Flag Extraction</i>	Possible exploitation of the stealing to determine the channel mode and/or recover some in-band signaling	
<i>De-Interleaving</i>	Possible new De-interleaving schemes for some or all channel modes of AMR	
<i>Channel Decoding</i>	Support of a new channel decoding mode for each codec	
<i>Speech Decoding Bad Frame Handling In Band Signaling</i>	Support of a set of new speech decoding algorithms for the full rate and half rate modes of AMR Possible new bad frame handling algorithms Extraction of the In Band signaling	New speech decoding algorithm for EFR New bad frame handling algorithm
<i>TX In Band signaling</i>	Generation of an In Band signaling message containing either measurement reports and/or downlink codec requirement and/or indication.	
<i>Resource Management</i>	Possible impacted messages/procedures include: Measurement Reports (to partially report the new metric on the SACCH) System Information (to define the operation thresholds of the channel adaptation)	
<i>Call Control Layer 3</i>	Codec negotiation/selection at call set up (Bearer Capabilities) Channel Mode indication in Assignment/Handover Command	Codec indication at call set up (Bearer Capabilities) Channel Mode indication in Assignment/Handover Commands

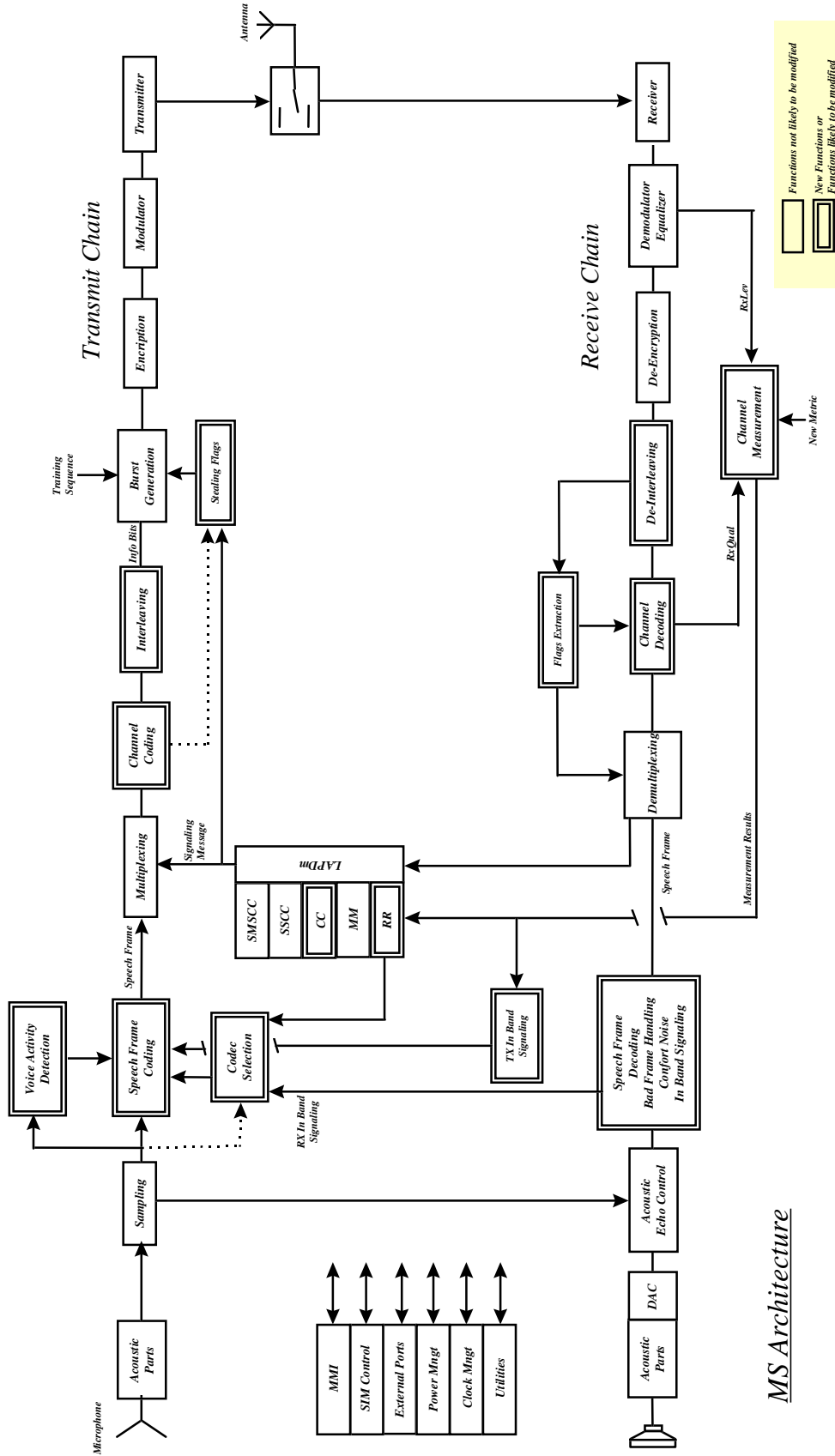

---

## Annex E      Speech traffic channel simulator

This annex contains a short description of the different blocks involved in the speech traffic channel simulator.

### **AMR encoder**

It contains the algorithms for speech encoding, channel encoding as well as voice activity detection and DTX functions. All these algorithms are considered to be part of the *codec proposal* and are left to the proponent. [*DTX algorithms are not mandatory to be included in the first proposal, still to be confirmed !!!*]. The encoder shall be capable to operate at HR or FR mode on demand (driven by the HR/FR flag). The encoder shall be capable to operate at different codec modes selected on the basis of the side information for codec control. The AMR encoder can also contain a suitable algorithm for codec mode adaptation.

The information on the encoding rate is considered to be part of the speech information and it is signaled in-band or using frame stealing flag techniques according to the codec proponent algorithm.

The information on HR/FR mode is intended to be signaled out of band with the current mechanism.

The input signal is the standard 16 bit linear PCM signal. The output signal is the data stream at 11.4 or 22.8 kbit/s already interleaved as in the cases of half-rate and enhanced full-rate exercises. It also shall contain the necessary in-band signaling for proper operation, this means for instance the actual operating rate and the feedback on the channel quality estimation.

### **EID Error Insertion Device**

The error insertion device allows error insertion with soft-chip output in either HR or FR operating modes.

It is complying with the assumptions made in the HR and EFR specifications.

The HR/FR flag is used to properly consider the soft-chip error patterns.

The HR/FR flag is transferred without any error simulation on it.

### **Error pattern**

Suitable error patterns shall be defined and made available for testing. They should carry the information on the soft chip errors as well as associated RxQual and RxLev.

### **AMR decoder**

The AMR decoder contains the algorithms for channel decoding, error concealment, speech decoding as well as comfort noise and DTX functions. All the algorithms are up to the codec proponents.

The AMR decoder can also contain a suitable algorithm for codec mode adaptation.

### **Delay**

The side information for codec mode control shall be transferred to the backward channel by taking into account the proper delay involved that can be different for different proposals depending on the location of the codec mode adaptation algorithm and on the in-band signaling protocol used.

### **AMR signaling encoder**

The AMR signaling encoder has the purpose to encode the required side information for codec mode adaptation. It could contain the complete AMR encoder, or it can be a simplified version in which only the signaling part is included. The other portion of information can be filled with random bits. It is part of the candidate proposal.

A suitable DTX pattern must however be used in order to take into account of switching on and off the transmitter and consequently the impact on the signaling rate and on the performance in dynamic operation.

### **AMR signaling decoder**

It contains the decoding functions of the in-band signaling. Also in this case it can be the complete AMR decoder or a simplified version. It is again up to the codec proponent. Its use is to decode the side information for codec mode adaptation.

## Annex F Schedule for AMR development

The schedule for the AMR development and standardization outlined below was produced by SMG11 at its meeting in September '97. Subsequently, SMG2 WPB indicated that the static and dynamic error patterns needed for the Qualification Tests would not be available until December '97 and March '98 respectively. This will clearly impact the feasibility of completing the work in time for Release '98. The schedule therefore needs to be reviewed by SMG11 and SMG2 to arrive at a common acceptable plan.

Date	Activity
October 1997	<ul style="list-style-type: none"> <li>■ Definition of the Terms of Reference.</li> <li>■ Approval of the Feasibility Report at TC SMG#23.</li> </ul>
November 1997	<ul style="list-style-type: none"> <li>- Definition of the system simulator, references and error profiles.</li> <li>- Definition of qualification test plan / Provision of references.</li> <li>- Definition of qualification and selection rules.</li> <li>- Declaration of intention to submit a candidate.</li> <li>- Start the development of the system simulator for the selection phase.</li> <li>- Start the definition of test plans for the selection phase.</li> <li>- Start the organization of the host laboratory session for selection phase.</li> </ul>
T <sub>0</sub> March 1998	<p>Information to be provided for consideration of candidate algorithms:</p> <ul style="list-style-type: none"> <li>• High-level description of the proposed algorithm.</li> <li>• Qualification test results of the candidate algorithm according to the qualification test procedure.</li> <li>• Additional information from the proponents, e.g. convergence time and complexity of the proposed algorithm.</li> <li>• Demo-tape, e.g. a DAT tape, with processed speech (+ noise) material. Description of the acoustic/environmental conditions used for the recordings (e.g. audio parts, S/N ratios, frequency bandwidth, etc.)</li> <li>• Written statement on IPR (according to the "ETSI Patent Policy")</li> <li>- Continue the definition of test plan for the selection phase.</li> <li>- Continue the organization of the laboratory sessions for the selection phase.</li> </ul>
T <sub>0</sub> + 2 months (May 1998)	<ul style="list-style-type: none"> <li>- Completion of test plans for the selection phase.</li> <li>- Submission of detailed description of candidate algorithms.</li> <li>- Completion of the system simulator</li> <li>- Submission of software simulations to host laborator(y)/ies.</li> <li>- Start subjective tests for the selection phase</li> </ul>
T <sub>0</sub> + 4 months (July 1998)	<ul style="list-style-type: none"> <li>- Evaluation of the results of the selection phase.</li> <li>- Evaluation of algorithm complexity.</li> <li>- Selection of one candidate for further consideration (optimization).</li> <li>- Start of the definition of test plan for the characterization phase. <ul style="list-style-type: none"> <li>- TFO Outline Enhancement.</li> <li>- SMG2 Outline Channel Control Standard.</li> <li>- Start DTX definition.</li> </ul> </li> <li>- Start development of test vectors and signaling type approval testing.</li> </ul>

- $T_0 + 6$  months  
(September  
1998)
- Review of available results for candidate or compromise algorithm.
  - Agreement on selected algorithm.
  - Definition of test plan for the characterization phase.
  - Definition of the laboratory session for the characterization test.
  - Start development of algorithm implementation verification tests.
  - Description of TFO mechanism.
  - SMG2 Channel Control metric definition.
  - Description of DTX proposal.
- $T_0 + 8$  months  
(November  
1998)
- Completion of the characterization phase.
  - Evaluation of the results of the characterization test.
  - Complete the set of AMR standards.
  - Finalize Channel Control/Metric specifications.
  - Finalize TFO mechanism.
  - Complete the DTX standard.
  - STCs (SMG2/SMG3/SMG7/SMG8/SMG11) approval.
  - Implementation of algorithm on different platforms
- $T_0 + 9$  months  
(December  
1998)
- Completion of algorithm implementation verification test procedures.
  - TC SMG approval.

Start of Phase 2

---

## Annex G Work Item Description for AMR

### 1. Adaptive Multi-Rate codec

#### 1.1 Justification

During 1995/6, the SQSG (Speech Quality Strategy Group) reviewed the need for any future GSM codecs and presented its recommendations to SMG#20. It concluded that the future needs of GSM users would be well served by the development of a single new speech codec.

With competition in the fast changing Telecommunications environment, the convergence of different forms of network access, and customer expectations will place great demands on network quality. For GSM to successfully compete in this environment, GSM must be capable of offering wireline speech quality that is robust to adverse conditions such as channel errors, background noise and tandeming. Whilst current codecs achieve good performance under most conditions, there remain some shortfalls, particularly in respect of realizing wireline quality half-rate operation and maintaining good quality under high error conditions.

The Adaptive Multi-Rate (AMR) solution offers high quality half-rate operation yielding capacity enhancements and cost savings and it also offers wireline quality in full-rate mode that is highly robust to channel errors.

#### Wideband

There is also growing market interest in a wideband speech service (e.g. 7 kHz) and a wideband mode may also be included in the AMR codec. If this mode is to be included, it should not delay the development of the narrowband speech application of AMR.

#### 1.2 Service Aspects

The main requirements of the AMR codec are to provide

- consistent wireline quality even under variable radio channel conditions
- wireline half-rate operation, possibly restricted to low error rates
- the flexibility for operators to optimize the balance of capacity and quality.

If the scope of AMR is extended to include a new wideband speech service option, the nature of this service will need to be determined.

#### 1.3 MMI-Aspects

None

#### 1.4 Charging Aspects

The option to be able to charge for use of the AMR codec is to be reviewed.

#### 1.5 Security Aspects

None

**1.6 Impacts**

Affects:	SIM	ME	NW	Others
Yes		✓	✓	
No	✓			
Don't know				

**1.7 Expected Output and Time-scales (to be updated at each plenary)**

New specifications						
GSM No.	Title	Prime resp. STC	Secondary resp. STC(s)	presented for information at SMG#	approved at SMG#	Comments
	tbd	SMG11	SMG2 SMG3			

Affected existing specifications				
GSM No.	CR	Subject	Approved at SMG#	Comments
		tbd		

[ffs]

**1.8 Rapporteur(s)**

K. Järvinen

**1.9 Others**