

**3rd Generation Partnership Project (3GPP);
TSG-SA Codec Working Group;
QoS for Speech and Multimedia Codec
Quantitative performance evaluation of H.324 Annex C over 3G**

3GPP

Reference

<Workitem> (<Shortfilename>.PDF)

Keywords

<keyword[, keyword]>

3GPP

Postal address

Office address

Internet

secretariat@3gpp.org
Individual copies of this deliverable
can be downloaded from
<http://www.3gpp.org>

Copyright Notification

No part may be reproduced except as authorized by written permission.
The copyright and the foregoing restriction extend to reproduction in all media.

©
All rights reserved.

Contents

Intellectual Property Rights	5
Foreword	5
1 Scope.....	6
2 References	6
3 Definitions, symbols and abbreviations.....	6
3.1 Definitions	6
3.2 Symbols	6
3.3 Abbreviations.....	7
4 3GPP Configuration of H.324 annex C	8
5 Performance	9
5.1 Audio	9
5.1.1 Introduction.....	9
5.1.2 Test environment.....	9
5.1.3 Results.....	9
5.2 Video	10
5.2.1 Introduction.....	10
5.2.2 Test environment.....	10
5.2.3 Results.....	10
5.2.3.1 Subjective results.....	11
5.2.3.2 Objective results.....	12
5.2.3.3 Delay	14
5.3 Control.....	15
5.3.1 Introduction.....	15
5.3.2 Test environment.....	15
5.3.3 Results.....	15
5.4 Data.....	15
5.4.1 Introduction.....	15
5.4.2 Test environment.....	15
5.4.3 Results.....	15
Annex A	16
Annex B	17
B.1 Introduction	17
B.2 Test Procedure.....	17
B.2.1 Simulation Model.....	17
B.2.2 Source materials	19
B.2.3 Source encoding.....	19
B.2.3.1 Speech	19
B.2.3.2 Video	19
B.2.4 Multiplexing.....	19
B.2.5 Bit error injection.....	20
B.2.5.1 Error pattern files.....	20
B.2.5.2 Error pattern segments to be used at the simulation	21
B.2.5.3 Injection of bit errors.....	21
B.2.6 De-multiplexing	21
B.2.7 Video decoding	22
B.2.8 Constraints and regulations	22
B.2.8.1 Delay	22
B.2.8.1.1 Video	22
B.2.9 Statistical data to be reported	22
B.2.9.1 Video coding bitrate [% 6.2f kbps] and MUX overhead [% 6.2f kbps]	22
B.2.9.2 Speech coding bitrate [% 6.2f kbps] and frame length [% d ms].....	22
B.2.9.3 Video initial delay [% 6.1f ms].....	22

B.2.9.4	PSNR related data	22
B.2.9.4.1	Total average PSNR, i.e., $PSNR_{total}$ [%6.2f dB].....	23
B.2.9.4.2	Average PSNR for representative run, i.e., $PSNR_{k*}$ [%6.2f dB]	23
B.2.9.4.3	Average PSNR in error-free case, i.e., $PSNR_{free}$ [%6.2f dB]	23
B.2.9.4.4	Standard deviation of PSNR, i.e., Σ [%6.2f dB]	23
B.2.9.5	Coding frame rate [%5.2f frames/sec]	23
B.2.9.6	Average dropframe rate [%6.2f %].....	23
B.2.9.7	Out of delay constraints rate [%6.2f %].....	24
B.2.9.8	Definition of video stationary delay	24
B.2.9.9	Decoded video of representative run	24
B.3	Subjective quality evaluation	24
B.3.1	Structure of test	25
B.3.1.1	Program	25
B.3.1.2	Training session.....	25
B.3.1.3	Scoring session	25
B.3.1.4	Video sequence.....	25
B.3.1.5	Structure of program.....	25
B.3.2	Editing process.....	25
B.3.2.1	Producing training session	26
B.3.2.2	Randomization.....	26
B.3.3	Assessment	26
B.3.3.1	Test subjects	26
B.3.3.2	Facilities and equipment for test.....	27
B.3.3.3	Score sheet.....	27
B.3.4	Data processing	28
B.3.4.1	MOS [%4.2f]	28
B.3.4.2	Standard deviation of OS, i.e., σ_{os} [%4.2f]	28
B.4	Test results and observations	28
B.4.1	Test results	28
B.4.2	Observations.....	28
B.5	List of video/speech codecs and multiplexers employed in the simulation.....	29
B.6	Test results.....	31
Annex C	37
Annex D	37

Intellectual Property Rights

Foreword

This Technical Report has been produced by the 3rd Generation Partnership Project, Technical Specification Group Services and System Aspects, Working group 4 (Codec).

The contents of this TR may be subject to continuing work within the 3GPP and may change following formal TSG approval. Should the TSG modify the contents of this TR, it will be re-released with an identifying change of release date and an increase in version number as follows:

Version m.t.e

where:

- m indicates [major version number]
- x the second digit is incremented for all changes of substance, i.e. technical enhancements, corrections, updates, etc.
- y the third digit is incremented when editorial only changes have been incorporated into the specification.

1 Scope

The present document is meant to function as guidance in the work of other 3GPP work groups or work items. Such work may include conclusion on how to achieve detailed Stage 1 service requirements or suggestion of a set of recommended RAB parameters giving satisfactory user-to-user quality for a circuit switched multimedia service using 3G-324M.

2 References

The following documents contain provisions, which, through reference in this text, constitute provisions of the present document.

- References are either specific (identified by date of publication, edition number, version number, etc.) or non-specific.
- For a specific reference, subsequent revisions do not apply.
- For a non-specific reference, the latest version applies.
- A non-specific reference to an ETS shall also be taken to refer to later versions published as an EN with the same number.

- [1] "Volume 3; Specifications of air-interface for 3G mobile system (Version 1.0-0.3)", IMT-2000 Study Committee, Air-Interface WG/SWG2, Nov. 18th, 1998.
- [2] "Volume 8; Codec specification for use in a 3G mobile system (Version 0.5.2)", IMT-2000 Study Committee, Codec WG (ARIB), July 21st, 1998.
- [3] ISO/IEC 14496-2 Final Draft of International Standard, "Information technology - generic coding of audio-visual objects: Part2-Visual", ISO/IEC JTC1/SC29/WG11 N2502, Nov. 1998.
- [4] ITU-T Recommendation H.263, "Video coding for low bit rate communication", Feb. 1998.
- [5] ITU-T COM16-79, "Draft revised Recommendation H.245 - Version 5", January 1999.
- [6] H.223
- [7] H.324

3 Definitions, symbols and abbreviations

3.1 Definitions

For the purposes of the present document, the [following] terms and definitions [given in ... and the following] apply.

Codec: a single media coder/decoder, or a multimedia system specific coder & decoder system. For example, 3GPP AMR (speech codec), ITU-T H.263 (video codec) or ITU-T H.32x (multimedia system with included media codecs) are understood to fulfil the definition of a codec.

3.2 Symbols

For the purposes of the present document, the following symbols apply:

<symbol> <Explanation>

3.3 Abbreviations

For the purposes of the present document, the following abbreviations apply:

3G	Third Generation Mobile Network
5DQS	5 step Discrete Quality Scale
AC/DC	Alternate Current/Direct Current
AL1-AL3	Adaptation Layer 1-3
AL-SDU	Adaptation Layer – Service Data Unit
ARIB	Association of Radio Industries and Businesses
BER	residual Bit Error Ratio
BT 500-8	ITU-R Recommendation, “Methodology for the subjective assessment of the quality of television pictures”
CCSRL	Control Channel Segmentation and Reassembly Layer
CIF	Common Image Format (352x288 pixel)
CRC	Cyclic Redundancy Code
FEC	Forward Error Correction
FER	Frame Error Ratio
GSM	Global System for Mobile-communications
AMR	Adaptive Multi-Rate Speech Codec
H.223	ITU-T Recommendation, “Multiplexing protocol for low bit rate multimedia communication”
H.245	ITU-T Recommendation, “Control protocol for multimedia communication”
H.324	ITU-T Recommendation, “Terminal 1 for low bit rate multimedia communication”
IEC	International Electrotechnical Commission
IMT-2000	International Mobile Telecommunications - 2000
ISO	International Organization for Standardization
ITU-R	International Telecommunication Union – Radiocommunications Standardisation Sector
ITU-T	International Telecommunication Union – Telecommunications Standardisation Sector
I-VOP	Intra Video Object Plane
kbps	Kilo bits per second (used in Annex B)
LAPM	Link Access Procedure for Modem
LCD	Liquid Crystal Panel
MOS	Mean Opinion Score
MPEG	Moving Picture Expert Group
MUX-PDU	MUltipleX – Protocol Data Unit
PLMN	Public Land Mobile Network
PSNR	Peak Signal to Noise Ratio
P-VOP	Predicted Video Object Plane
QCIF	Quarter Common Image Format (176x144 pixel)
QoS	Quality of Service
SS	Single Stimulus
TM-5	Test Model 5
WCDMA	Wideband Code Division Multiple Access
VLC	Variable Length Code

TS xx.xx “Acronyms and definitions....” FFS provides the definitions not listed in this section.

4 3GPP Configuration of H.324 annex C

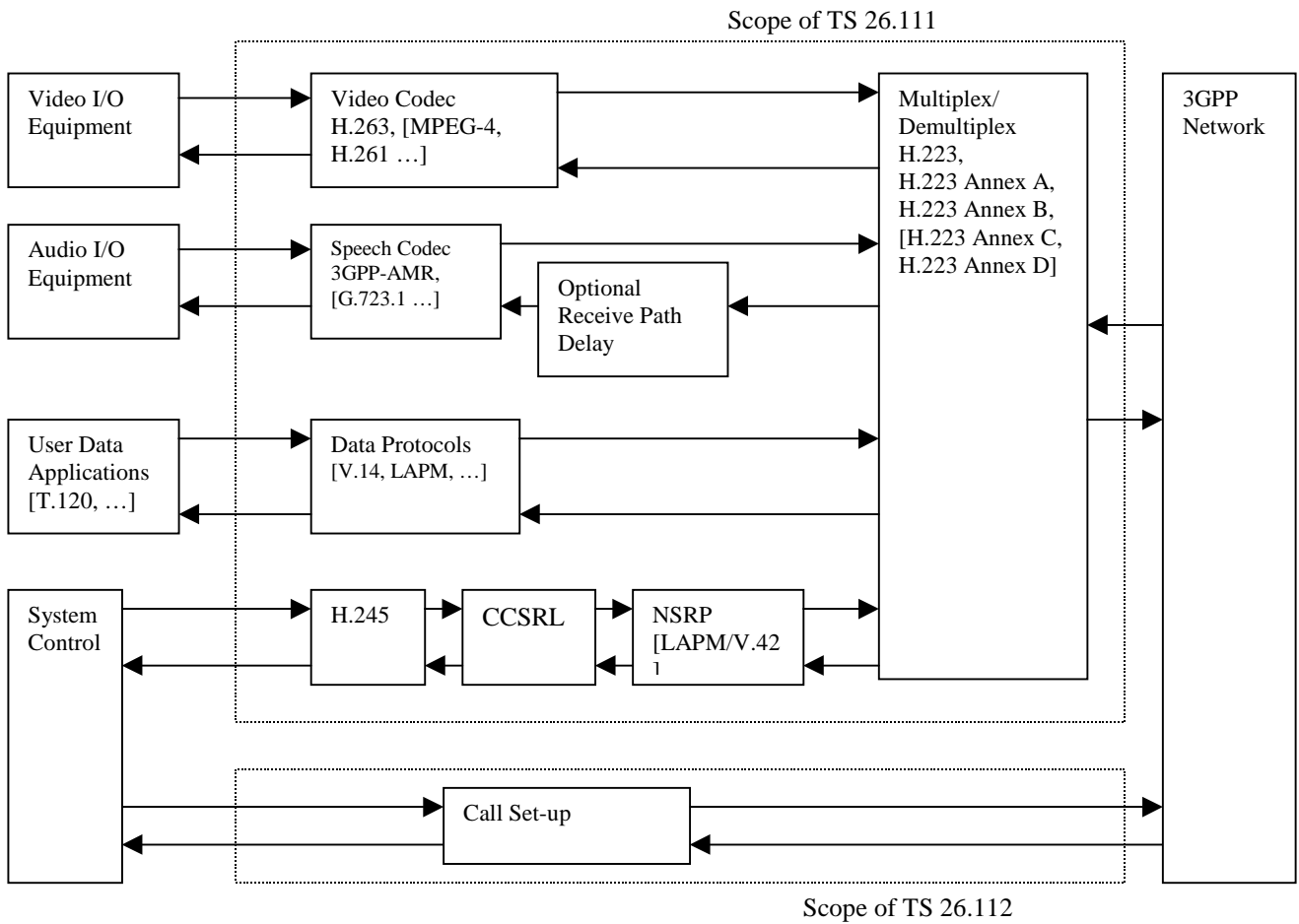

Figure 1

Figure 1 shows the main building block of a 3G-324M terminal. The standards inside [...] are not mandatory. The configuration actually used for each of the four performances evaluations (Audio, Video, Control and Data) will be described under each heading.

5 Performance

5.1 Audio

FFS

5.1.1 Introduction

FFS

5.1.2 Test environment

FFS

5.1.3 Results

FFS

[Ed. Note. Speech will probably give acceptable quality with higher bit error then video. The configuration of the multiplex might have certain influence on the performance.

The characterisation tests of GSM-AMR in GSM will give information about the error handling capability of GSM-AMR in 3G-324M even if the error characteristics for GSM-AMR is different from the one in 3G Systems.

It would be desirable if the characterisation tests of AMR in 3G Systems also included a test item where AMR is transported in a H.223 multiplexer.]

5.2 Video

5.2.1 Introduction

Qualitative evaluation of H.324 Annex C over a simulated WCDMA Channel was carried out by ARIB (Association of Radio Industries and Businesses) IMT-2000 Study committee March 1999. The purpose of the test was to clarify the relationship between source/channel codec parameters and the channel bit-error conditions. A short description of the evaluation and a presentation of the results are included. The full test report is included in Annex B.

5.2.2 Test environment

The ARIB simulation was carried out as follows;

- 1) source video sequences come into a video encoder
- 2) speech dummy data and video bitstreams are generated
- 3) the bitstreams are multiplexed into a single multiplexed bitstream in the form of MUX-PDU
- 4) bit errors are injected into the multiplexed bitstream ('1' in error pattern file represents error)
- 5) contaminated bitstream is de-multiplexed into speech and video bitstreams
- 6) de-multiplexed video bitstream is decoded by a video decoder
- 7) decoded video sequences are evaluated subjectively

A layered overview of the test set up is shown in table 1.

Layer	Entity	Instance
Application Layer	Video Codec	ISO MPEG-4 Simple Profile or ITU-T H.263 Ver.2
	Speech Codec	Dummy data
Mux Layer	Multiplexer De-multiplexer	H.223/M (mobile extension of ITU-T H.223 multiplexing protocol)
Physical Layer	Simulated Wideband CDMA-channel	Error pattern files – bitrate: 32 Kbit/s, 64 Kbit/s and 128 Kbit/s – channel error condition BER: 1e-3, 1e-4 and 1e-6 – velocity (model): 3km/h (Vehicular-A) and 120km/h (Vehicular-A)

Table 1

5.2.3 Results

The results presented below should be used carefully. The subjective evaluation performed by ARIB provides good insight into the quality aspects of 3G-324M. However, attention should be paid to the following shortcomings: the test lacks a well known reference which makes it hard to assess the absolute picture quality furthermore the test methodology for low quality video is not very well developed which might be the reason for the high deviation in the results.

The objective results presented should also be used carefully. It is very hard to map objective measurements to subjective quality. However high objective quality generally does mean that the subjective quality is good and vice versa.

5.2.3.1 Subjective results

The following graphs are built from a subset of the data found in table in Chapter B.6 of Annex B. Each codecs shown in the graphs had been tested for every error cases for each channel bit-rate. Since the evaluation lacked a known reference the MOS-values should be used very carefully. It is not the absolute value that is interesting but more the tendency.

For all three of the following graphs are the error channel described in the following way:

M64-10-3 where

M means Mobile-to-Mobile Channel, it could also be an F for a Fix-to-Mobile channel

64 stands for the total bitrate on the channel i.e. 64 Kbit/s, 128 means 128 Kbit/s

10 is the interleaving depth in ms, other possibilities is 20 and 80 ms

3 bit-error-rate i.e. 10e-3, other tested bit-error-rates are 10e-4 and 10e-6

Results from two different sequences are shown: Overtime and Australia. Overtime is a typical “head and shoulder” scene while Australia is a multi-person conference scene with camera motion. The later is known, from the MPEG4 verification tests, to be difficult to code. The Overtime sequence has QCIF and the Australia CIF resolution. The coded video frame rate was not fixed in the test, however most of the experimenter used a frame rate around 10 Hz. Full information about the test to be found in Annex B.

MOS versus bit-error-rate, 64kps, Overtime

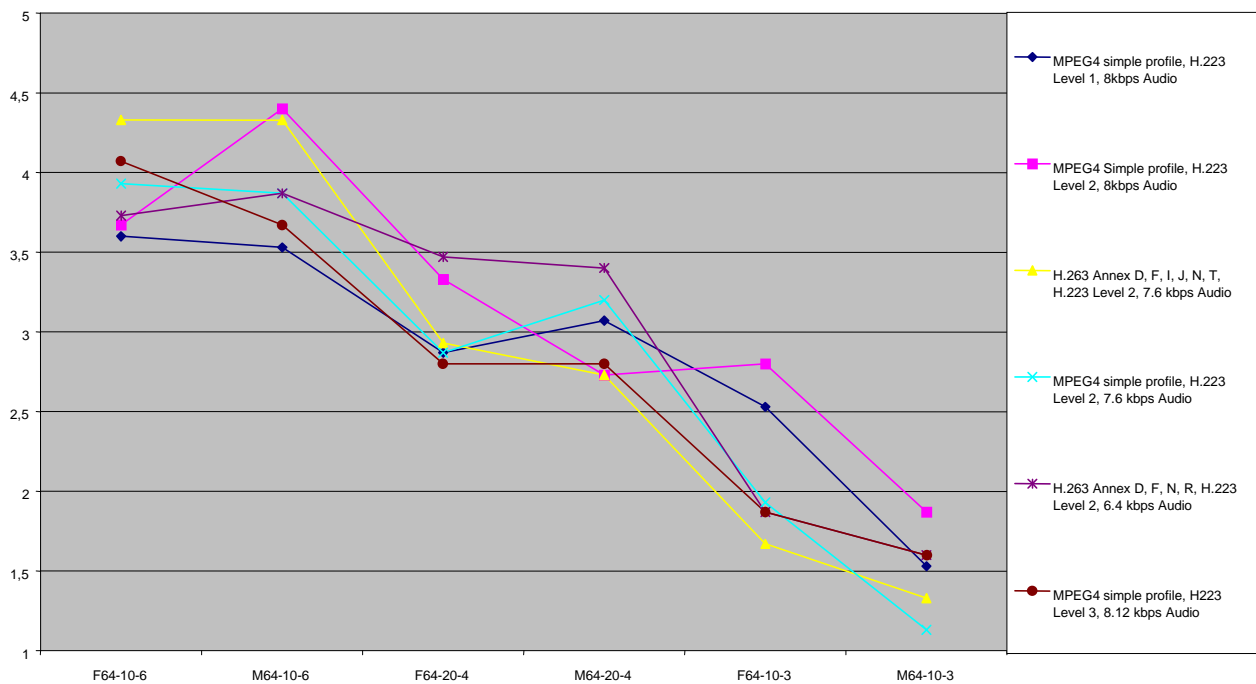

Mos versus bit-error-rate, 64kps, Australia

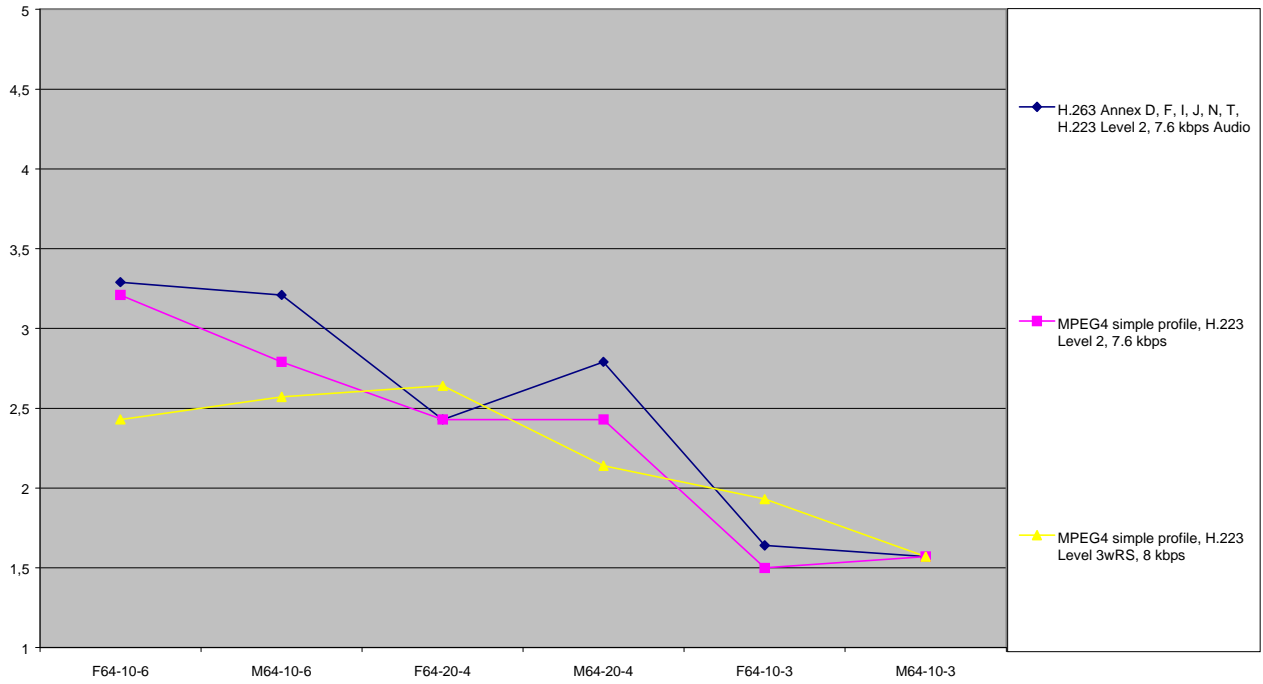

MOS versus bit-error-rate, 128 kps, Australia

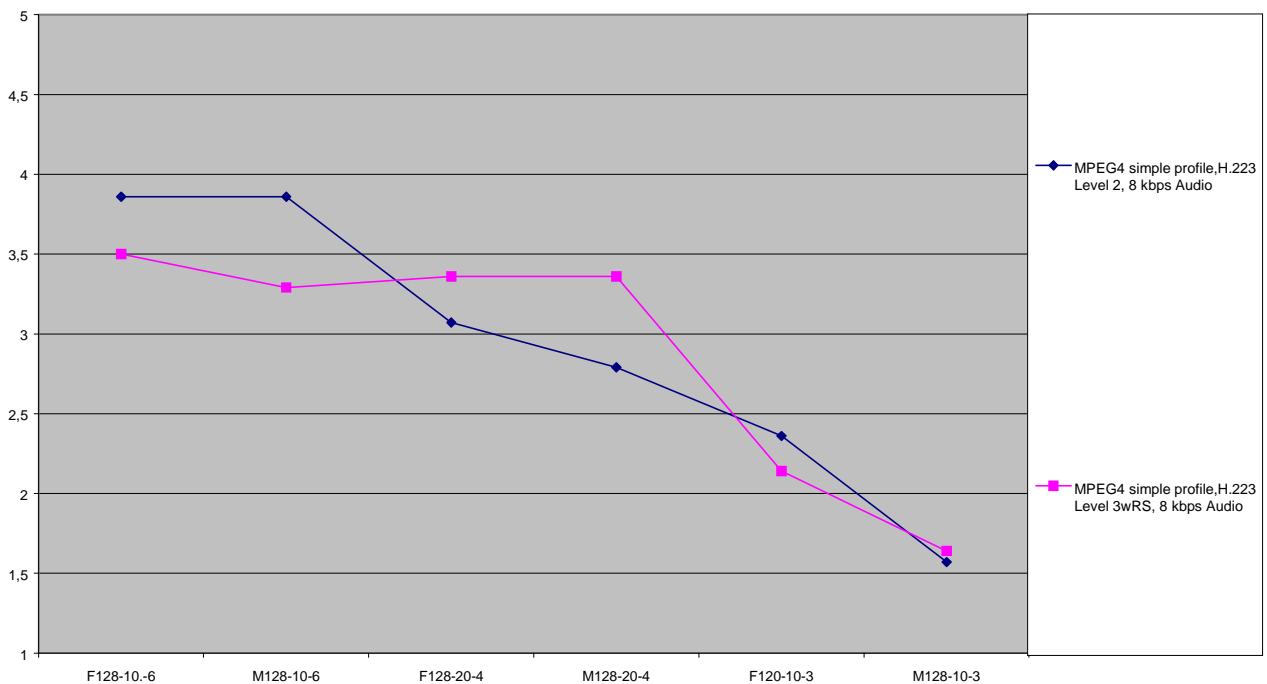

5.3.2.2 Objective results

As a comparison to the subjective results above, some objective data are presented for the same test cases. The tested sequence is Australia, two different bitrates are used (64 and 128 Kbit/s). Graphs for both Fix-to-Mobile and Mobile-to-Mobile are shown.

In these results, three different multiplex levels of H.223 were used for each condition. The description of the error channel is the same as 5.3.2.1. Additional description for multiplex levels is as following,

Lv2o: Level 2 with optional header,

Lv3r4: Level 3 with FEC (convolutional code with a rate of 8/12),

Lv3rs8: Level 3 with FEC (Reed Solomon code with 8 symbol correction).

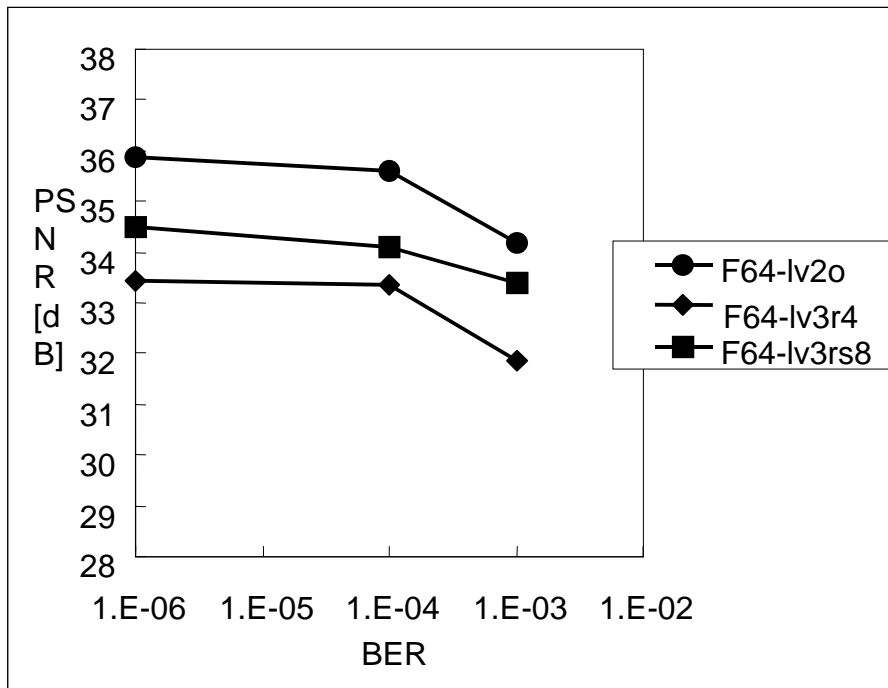

Figure 2 BER vs. PSNR performance (64 Kbit/s, Fix-to-Mobile)

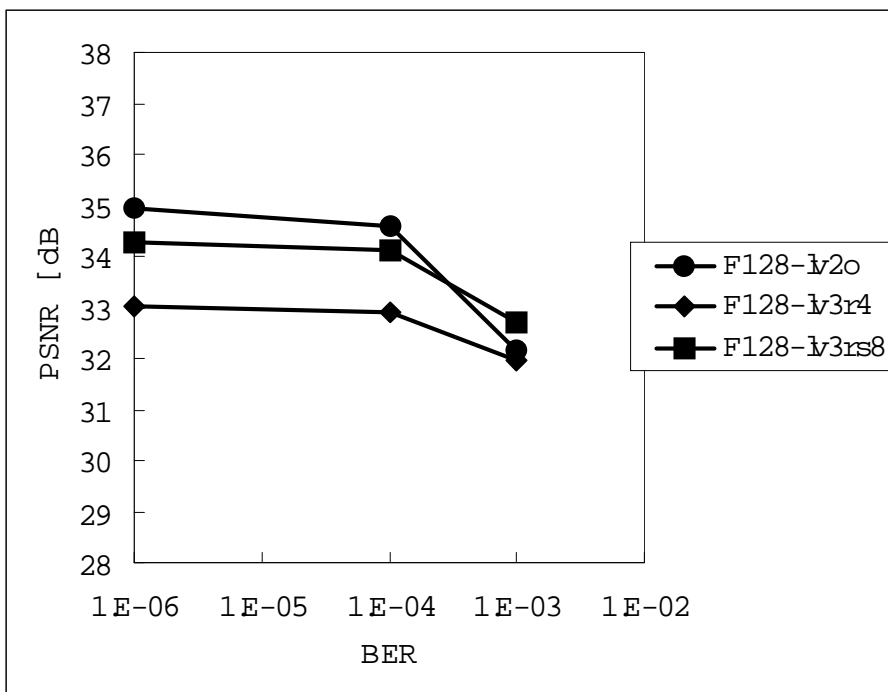

Figure 3 BER vs. PSNR performance (128 Kbit/s, Fix-to-Mobile)

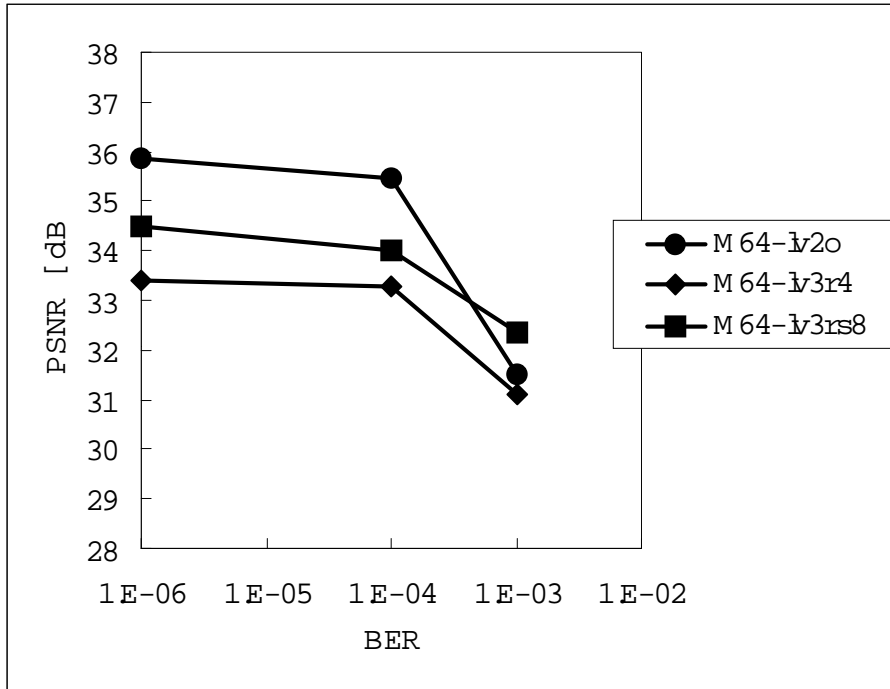

Figure 4 BER vs. PSNR performance (64 Kbit/s, Mobile-to-Mobile)

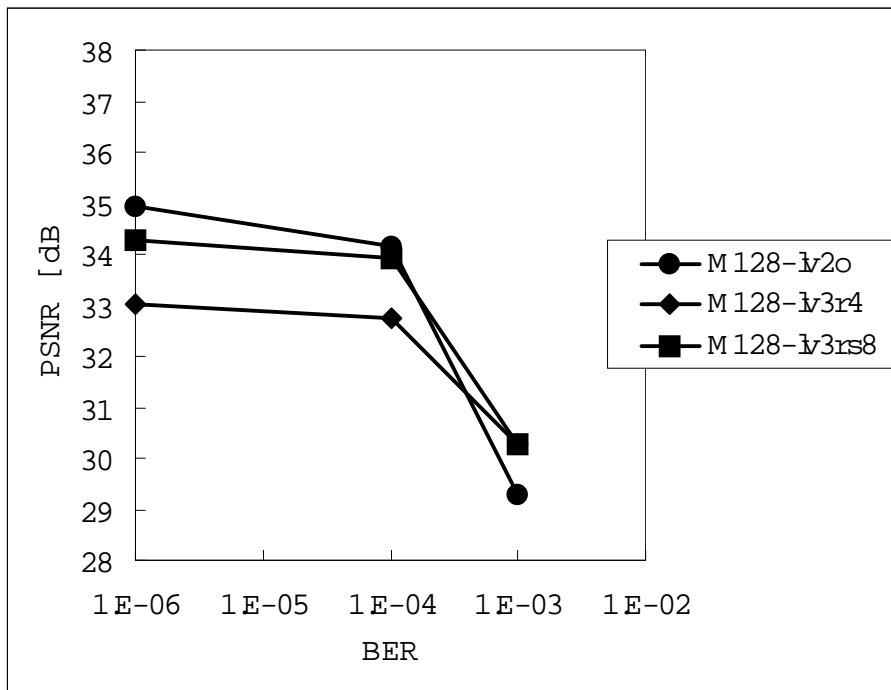

Figure 5 BER vs. PSNR performance (128 Kbit/s, Mobile-to-Mobile)

5.3.2.3 Delay

FFS

5.3 Control

5.3.1 Introduction

FFS

5.3.2 Test environment

FFS

5.3.3 Results

FFS

[Ed. Note. The main result will be the delay numbers under different error rates. The control channel is error free by application level retransmission, CCSRL, and will thus introduce delay. Bad selection of implementation parameters might, for example, lead to a non-completed capability exchange procedure.]

5.4 Data

FFS

5.4.1 Introduction

FFS

5.4.2 Test environment

FFS

5.4.3 Results

FFS

[Ed note. The results will consist of mean throughput and delay under different error conditions. The data channel is error free and will thus introduce delay and also limit the useful bit-rate.]

Annex A

[Ed note. The bulk of the Audio related information]

Annex B

B.1 Introduction

This Annex describes the simulation test of a real time, bi-directional video multimedia codec. It is a shorter version of the “Report of ARIB IMT-2000 Video Multimedia Codec Simulation Test” found in reference [2].

The purpose of the test is to clarify the relationship between source/channel codec parameters and the channel QoS (Quality of Service) parameters of available bearer channel set. While the source and channel codecs are specified with algorithms, tools, options and parameters, the channel QoS parameters include bitrate, BER (bit error rate) and delay. Resulting video associated with a certain combination of source/channel codec parameters and the channel QoS parameters is subjectively evaluated in terms of quality.

Twelve experimenters, that is, companies conducted the simulations. The experimenters individually and independently carry out the simulation using video codec and multiplexer prepared by each organization.

B.2 Test Procedure

B.2.1 Simulation Model

The system configuration of the simulation model for these experiments is depicted in Figure B1.

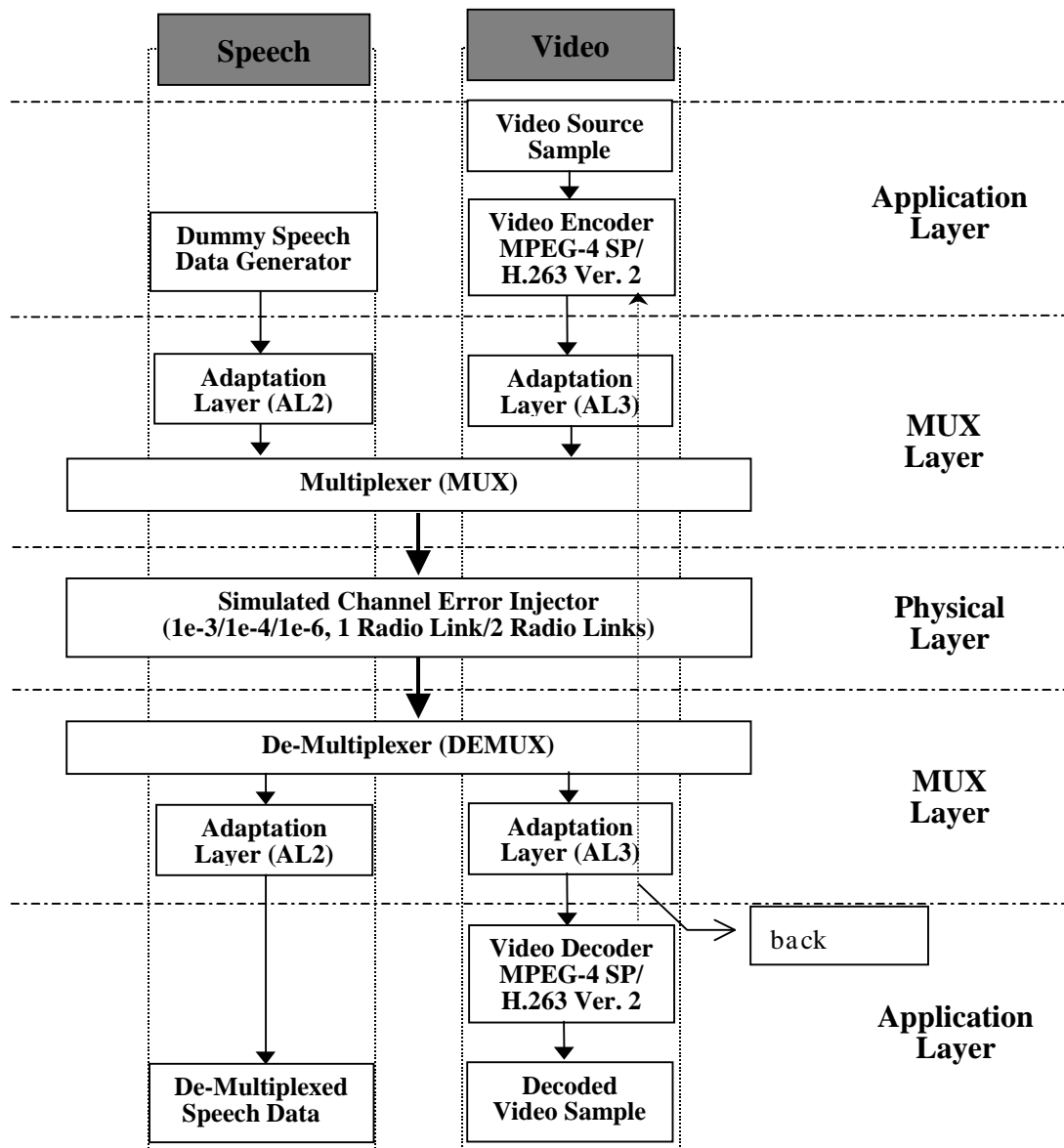

Figure B1: System configuration of simulation model

This model is a typical example of mobile multimedia communication systems, and consists of the following three layers as shown in Table B1.

Layer	Entity	Instance
Application Layer	Video Codec	ISO MPEG-4 Simple Profile or ITU-T H.263 Ver.2
	Speech Codec	dummy data
Mux Layer	Multiplexer De-multiplexer	H.223/M (mobile extension of ITU-T H.223 multiplexing protocol)
Physical Layer	IMT-2000 Air-Interface spec. (Vol. 3 Ver. 0.5)	error pattern files – bitrate: 32kbps, 64kbps and 128kbps – channel error condition BER: 1e-3, 1e-4 and 1e-6 – velocity (model): 3km/h (Vehicular-A) and 120km/h (Vehicular-A)

Table B1: Layer structure of simulation model

The simulation is generally carried out as follows;

- 1) source video sequences come into a video encoder,
- 2) speech dummy data and video bitstreams are generated,
- 3) the bitstreams are multiplexed into a single multiplexed bitstream in the form of MUX-PDU,

- 4) bit errors are injected into the multiplexed bitstream ('1' in error pattern file represents error),
- 5) contaminated bitstream is de-multiplexed into speech and video bitstreams,
- 6) de-multiplexed video bitstream is decoded by a video decoder,
- 7) decoded video sequences are evaluated subjectively.

B.2.2 Source materials

In the simulation two video sequences as shown in Table B2 are used.

Name	Provider	Spatial Resolution	Temporal Resolution	Length [sec]	Feature		
					Service assumed	Motion	Scene Change
Overtime	NTT DoCoMo	QCIF* ¹	30 fps	60	video telephony	low	no
Australia	France Telecom	QCIF* ¹ or CIF* ²	25 fps	60 (72* ³)	video conference	middle	twice
Note	*1 QCIF: 176 (width) x 144 (height), 4:2:0 chroma format *2 CIF : 352 (width) x 288 (height), 4:2:0 chroma format *3 Australia is handled as 60 sec sequence of 30 fps, though it's originally 72 sec of 25 fps						

Table B2: Video source material

B.2.3 Source encoding

Chapter B5 shows the list of video/speech codecs and multiplexers employed by experimenters for the simulation.

B.2.3.1 Speech

Dummy random data, which are generated by each experimenter, are used to simulate encoded speech bitstream. The assumed coding bitrate and frame lengths of dummy speech data are left at the experimenter's discretion.

B.2.3.2 Video

Either ISO MPEG-4 Video Simple Profile or ITU-T H.263 Ver. 2 is employed as a video codec. There are some optional tools and parameters that can be set at the encoder for both specifications. Each experimenter taking speech coding bitrate and MUX overhead into account shall decide the bitrate allocated to video coding. A typical example is 8 kbps speech, 48 kbps video and 8 kbps MUX overhead, which results in 64 kbps in total.

Some coding parameters are fixed to facilitate the simulation and demonstration by reducing the number of simulation conditions;

- 1) coding bitrate; 32 kbps and 64 kbps for Overtime, 64 kbps and 128 kbps for Australia,
- 2) spatial resolution of test sequence; QCIF for Overtime, CIF for Australia 128 kbps coding, and QCIF or CIF for Australia 64 kbps coding
- 3) initial frame alignment; the 1st frame of test sequence shall be encoded as 1st intra-coded frame. It is noted that coding frame rate is left at the experimenter's discretion.

B.2.4 Multiplexing

ITU-T H.223/M (mobile extension) with its annexes namely Annex A, Annex B, Annex C and Annex D is used as a multiplexing protocol. As for the adaptation layer, AL3 is used for video and AL2 for speech. The use of the optional tools like control field, re-transmission and the optional header field in the Annex B is up to the experimenters.

B.2.5 Bit error injection

B.2.5.1 Error pattern files

The bit error patterns are generated based on Vol. 3 Ver. 0.5 (ARIB IMT-2000 A/IF specification) [1] issued on Nov. 18th, 1998 [Ed. Note, This is a WCDMA channel]. The frame structure of the bit error file is shown in Figure B2, which is identical to the air channel frame assumed. The frame is in 10-msec unit, and each frame is composed of CRC (16 bits) and INFO bits (10-msec worth of user bitrate). The multiplexed or encoded bitstream is assumed to be transmitted as INFO bits on a frame basis. The 16-bit CRC is originally designed to detect errors in the corresponding INFO bits at the physical layer. It can, however, be exploited at the application layer (e.g., source codec and MUX). In this simulation, the CRC is not used, hence, the 16-bit CRC should be merely discarded. It shall be noted that the CRC may be able to improve the performance of use applications. This is left for further study.

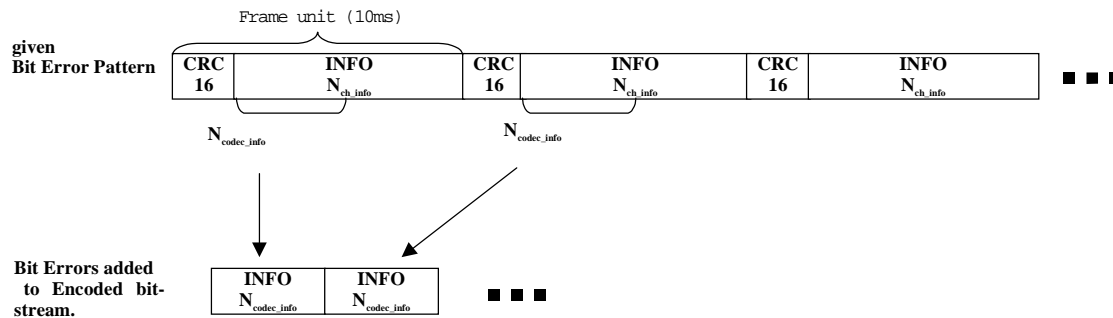

Figure B2: Frame structure of bit error pattern file

The bit error patterns in binary format are then provided as summarized in Table B3. Among them, the error pattern files of Vehicular-A, 120km/h propagation model are used for the test of mobile-to-land mode. The mobile-to-mobile (M2M) error pattern files weren't provided. M2M files was thus generated by XORing (exclusive OR) forward link and reverse link appropriately. Unfortunately reverse link files are available only for 32kbps, 1e-3 case. Therefore, error pattern of M2M mode are synthesized by XORing two forward link files that are the same in bitrate, BER and interleave length but only differ in propagation model. The two propagation models used are 3km/h and 120km/h of vehicular-A.

Table B3: Bit error pattern files

File Name	Radio Channel Type			BER	File Length [sec]	Speed [km/h]	Propagation model	Eb/Io [dB]	Ref. SG4/VMG File#			
	FL/ RL	Bitrate [kbps]	Interleave Size [msec]									
F32-10-3-V3a	FL	32	10	1e-3	300	3	Veh-A	2.57	SG4-7			
F32-10-3-V120a										120	Veh-A	3.93
F32-20-4-V3			20			1e-4	300	3	Veh-A	2.59	VMG-1	
F32-20-4-V120												120
F32-10-6-V3		10	1e-6	5000	3	Veh-A	3.96	SG4-41				
F32-10-6-V120a									120	Veh-A	5.63	SG4-43
F32-80-6-V3		80	1e-6	3200	3	Veh-A	2.42	SG4-45				
F32-80-6-V120a									120	Veh-A	3.66	SG4-47
F64-10-3-V3a		64	32	10	1e-3	300	3	Veh-A	2.18	SG4-13		
F64-10-3-V120a											120	Veh-A
F64-20-4-V3				20			1e-4	300	3	Veh-A	2.16	VMG-3
F64-20-4-V120												
F64-10-6-V3			10	1e-6	5000	3	Veh-A	3.63	SG4-25			
F64-10-6-V120a										120	Veh-A	5.06
F64-80-6-V3			80	1e-6	3200	3	Veh-A	2.00	SG4-29			
F64-80-6-V120a										120	Veh-A	3.28
F128-10-3-V3	128		32	10	1e-3	300	3	Veh-A	0.93	VMG-5		
F128-10-3-V120											120	Veh-A
F128-20-4-V3				20			1e-4	300	3	Veh-A		VMG-7
F128-20-4-V120												
F128-10-6-V3			10	1e-6	3000	3	Veh-A	2.24	SG4-49			

F128-10-6-V120a						120	Veh-A	3.91	SG4-51
F128-80-6-V3			80		1600	3	Veh-A	0.99	SG4-53
F128-80-6-V120a						120	Veh-A	1.98	SG4-55
R32-10-3-V3	RL	32	10	1e-3	300	3	Veh-A	2.48	VMG-9
R32-10-3-V120						120	Veh-A	3.86	VMG-10

B.2.5.2 Error pattern segments to be used at the simulation

Multiple-run simulation leads to more reliable results. Therefore it was decided to use 20 runs per error pattern file, i.e., parent file. It should be noted that the successive processes namely de-multiplexing and source decoding are repeated 20 times accordingly. An extracted file is denoted "error pattern segment", so 20 error pattern segments (denoted as seg#0 - seg#19) are extracted from each error pattern file. Note that duration of error pattern segments must be identical to that of test sequence, hence, 60 seconds for both Overtime and Australia. These error pattern segments, which shall represent respective test condition, are extracted as follows.

- In case of 1e-3 and 1e-4 BERs, 20 error pattern segments, initial frame of which are equally distributed over 5-min error pattern file, are extracted. Each segment is composed of successive frames in an error pattern file. The initial frame number of seg#0 is zero, and those of the following segments fall with fixed interval; 1200 frames (12 seconds).
- In case of 1e-6 BER, an intermediate file of 20 segments worth length, whose actual BER is as close to 1e-6 as possible, is sought over an error pattern file. Then 20 segments are extracted from the intermediate file. The initial frame of seg#0 collocates that of the intermediate file. As to the rest, they are extracted in the way that seg#N (where N=1,...,19) immediately follows seg#N-1.
- Firstly, 20 error pattern segments are extracted for each propagation model. The M2M error pattern segments are generated by XORing these extracted segments. In this process segment number must be matched, that is, XORing seg#N (where N=0,...,19) of 3km/h model and seg#N of 120km/h model yields seg#N of M2M model.

B.2.5.3 Injection of bit errors

To simulate the noisy channel, those bit errors are injected into multiplexed bitstream. This process is done by XOR in bit-wise fashion. But the initial error free period is tailored to protect the important part of the bitstream, since errors on such portion probably cause fatal damages in the source decoding process. Therefore the initial 100 bytes from the beginning of the multiplexed bitstream, which is denoted error-free period, are enforced to be error-free. So bit errors are injected immediately after the error-free period in multiplexed bitstream (Precisely the 1st bit of error patterns shall collocate 801st bit (both counting from one) of the multiplexed bitstream). If multiplexed bitstream is longer than error pattern segment plus 100 bytes, no error is applied to the tail part of the bitstream exceeding the length of error pattern segment plus 100 bytes. ITU-T H.245 Version 5 [5] is designed to perform a capability exchange prior to the transmission of data streams. With this technique, the initial error-free period can be realized by means of re-transmission.

B.2.6 De-multiplexing

The multiplexed bitstream is de-multiplexed at the receiver side. This process comes out with de-multiplexed speech bitstream and de-multiplexed video bitstream in the form of AL-SDU. Errors may be detected in some units of those bitstream with error detection capability of the multiplexing protocol. In that case it is up to the experimenter to decide whether erroneous AL-SDUs are delivered to the AL user, i.e., video decoder, or simply discarded. When erroneous AL-SDUs are delivered to respective AL user, it is possible that the AL user is notified of the presence of errors in delivered AL-SDU by the de-multiplexer

B.2.7 Video decoding

The de-multiplexed video bitstream is decoded. The video decoder has less freedom in selecting optional tools compared to the encoder, but has more freedom of operation outside of the standard, e.g., error detection, error recovery, error concealment and post processing. The use of these non-normative tools and proprietary schemes is up to the experimenters. To align the spatial resolution at subjective evaluation test, "Australia" sequence encoded at QCIF size shall be up-sampled to CIF size. Then "Overtime" and "Australia" sequences are displayed at the size of QCIF and CIF, respectively. For QCIF-to-CIF conversion, the up-sampling filter [FILTER] employed at MPEG-4 experiments is used.

B.2.8 Constraints and regulations

B.2.8.1 Delay

In considering adequate combination of bearer radio channel and codec parameters, both channel and codec affect the delay. Therefore the delay constraints shall be investigated in both aspects simultaneously. Table B4 summarizes the delay constraints to meet. It shall be noted that delay due to multiplexing/de-multiplexing heavily depends on the system configuration. Given that processing power of MUX related components are high enough, the delay at MUX layer can be absorbed into the video delay. So in the simulation, it is assumed that the delay at MUX layer is negligible, i.e., zero.

Total allowable delay	Allowable delay for air interface, network	Allowable delay for codec and MUX	Associated BER
400 ms	10x2*,50	330	1e-3, 1e-6
	20x2*,50	310	1e-4
	80x2*,50	190	1e-6
Note: *	multiplying by 2 means two links for mobile-to-mobile		

Table B4: Delay constraints

B.2.8.1.1 Video

The video delay is classified into two; initial delay and stationary delay. The former is defined with coding bits consumed at the 1st intra-coded frame, and is quantified by the coding bits divided by video coding bitrate. In the subjective test, when the initial delay exceeds 600 ms, mid-gray background is displayed with duration identical to the initial delay before presenting decoded video sequence. The latter is the one calculated based on the delay model described in B2.9.8. It is, however, found difficult and impractical to always keep the stationary delay below the prescribed values shown in Table B4 considering a variety of natures of input video sequences. While the experimenters are yet strongly encouraged to obey the above constraints, they are exceptionally allowed not to do. It is noted that such violation is admitted only when it is essential and rather practical than obeying the constraints.

B.2.9 Statistical data to be reported

The following items shall be reported on a test condition basis, i.e., one per error pattern file.

B.2.9.1 Video coding bitrate [%6.2f kbps] and MUX overhead [%6.2f kbps]

B.2.9.2 Speech coding bitrate [%6.2f kbps] and frame length [%d ms]

B.2.9.3 Video initial delay [%6.1f ms]

The video initial delay is calculated as coding bits for initial intra-coded frame divided by video coding bitrate

B.2.9.4 PSNR related data

The PSNR_{k,l} (peak signal-to-noise ratio) of *l*-th frame at *k*-th run is defined as;

$$PSNR_{k,l} = 10 \log \left\{ \frac{1.5 * M * N * (255)^2}{\sum_{i=0}^{M-1} \sum_{j=0}^{N-1} (Y(i,j) - \hat{Y}(i,j))^2 + \sum_{i=0}^{M/2-1} \sum_{j=0}^{N/2-1} (Cr(i,j) - \hat{Cr}(i,j))^2 + \sum_{i=0}^{M/2-1} \sum_{j=0}^{N/2-1} (Cb(i,j) - \hat{Cb}(i,j))^2} \right\}$$

where $Y(i, j)$, $Cr(i, j)$, $Cb(i, j)$ and $\hat{Y}(i, j)$, $\hat{Cr}(i, j)$, $\hat{Cb}(i, j)$ indicate the three channels of the original and decoded frames, respectively, and M and N indicate the Y channel support for 4:2:0. Practically, $M = 176$ and $N = 144$ for QCIF format and $M = 352$ and $N = 288$ for CIF format

B.2.9.4.1 Total average PSNR, i.e., $PSNR_{total}$ [%6.2f dB]

Now at the decoder, let $is_decoded(k, l)$ be a function which returns '1' if l -th frame at k -th run is decoded, and otherwise returns '0' representing "dropframe" (e.g., it occurs when a frame can't be reconstructed due to errors). Total average PSNR denoted by $PSNR_{total}$ is defined as;

$$PSNR_{total} = \sum_{k=0}^{19} \sum_{l=0}^{1799} \frac{is_decoded(k,l) \times PSNR_{k,l}}{is_decoded(k,l) \times 20}$$

B.2.9.4.2 Average PSNR for representative run, i.e., $PSNR_{k^*}$ [%6.2f dB]

Firstly average PSNR at k -th run denoted by $PSNR_k$ is obtained;

The representative run k^* is chosen from among 20 candidates $PSNR_k$, where $k=0, \dots, 19$. The selection criterion is

$$PSNR_k = \sum_{l=0}^{1799} \frac{is_decoded(k,l) \times PSNR_{k,l}}{is_decoded(k,l)}$$

that $PSNR_{k^*}$ is the one closest to $PSNR_{total}$.

B.2.9.4.3 Average PSNR in error-free case, i.e., $PSNR_{free}$ [%6.2f dB]

The average PSNR in error-free case represented by $PSNR_{free}$ is obtained in the similar way above. To precisely define the term, it is the average PSNR calculated when decoding error-free video bitstream.

B.2.9.4.4 Standard deviation of PSNR, i.e., Sigma [%6.2f dB]

$$Sigma = \sqrt{\sum_{k=0}^{19} \frac{(PSNR_{total} - PSNR_k)^2}{19}}$$

The Sigma is represented as;

B.2.9.5 Coding frame rate [%5.2f frames/sec]

Like $is_decoded(k, l)$, let $is_encoded(l)$ denote a function which returns '1' if l -th frame is encoded at the encoder, and otherwise returns '0'. The coding frame rate is expressed as;

$$coding_frame_rate = \sum_{l=0}^{1799} \frac{is_encoded(l)}{60}$$

B.2.9.6 Average dropframe rate [%6.2f %]

The average dropframe rate is defined as;

$$average_dropframe_rate = 100 \times \sum_{k=0}^{19} \sum_{l=0}^{1799} \frac{|is_encoded(l) - is_decoded(k,l)|}{is_encoded(l)}$$

B.2.9.7 Out of delay constraints rate [%6.2f %]

Let $is_outofdelay(l)$ represent a function which returns '1' if the delay constraints can not be observed at l -th frame, and otherwise returns '0'. Note $is_outofdelay(l)$ is meaningful only when the l -th frame is encoded, i.e., $is_encoded(l)=1$. Now the out of delay constraints rate is defined as;

$$out_of_delay_constraint_rate = 100 \times \frac{\sum_{l=0}^{1799} is_encoded(l) \& is_outofdelay(l)}{is_encoded(l)}$$

B.2.9.8 Definition of video stationary delay

The video stationary delay, D_n , for the n -th ($n = 1, 2, \dots$) coded frame in the transmitted sequence is defined as follows (the delay model defined has no relation between the buffering model described in the MPEG-4 [3] or H.263 [4] specification):

$$D_n = T_n - O_n,$$

where O_n denotes the time when the n -th coded frame occurs, and T_n denotes the time when the last bit of the coded information related to the n -th coded frame is transmitted from the transmitting side.

For example, when the video information is coded at the fixed bitrate of R bits/s, D_n is defined as follows:

$$D_n = O_1 + \frac{\sum_{i=1}^n B_i}{R} - O_n,$$

where B_n is the number of transmitted bits for the n -th coded frame.

The encoder shall encode a frame which occurred before the transmission of the information related to the previous coded frame is finished. This condition is described as:

$$O_n \leq T_{n-1}.$$

In the fixed bitrate case, this equation is rewritten as:

$$O_n \leq O_1 + \frac{\sum_{i=1}^{n-1} B_i}{R}.$$

B.2.9.9 Decoded video of representative run

The decoded video sequence shall ideally be displayed as it is demonstrated using actual real time codec. It is, however, found difficult for all experimenters to tailor such real time codec. Therefore, experimenters shall submit the decoded video of representative run. For simplicity sake, the decoded video is displayed according to the time stamp of encoded frames, assuming the time stamp is not so much deviated from presentation time at decoder.

B.3 Subjective quality evaluation

The video subjective quality evaluation test is performed based on so-called SS-5DQS, that is, single stimulus (SS) method with a 5-point discrete quality scale (5DQS) referred to as ITU-R BT 500-8. However, the test is not designed to be fully compliant to SS-5DQS, but is rather simplified. There are five grades; excellent, good, fair, poor and bad. It shall be noted that the grading is made under the assumption that those video sequences, hence, associated video codecs are employed for prospective IMT-2000 mobile terminals. In this context, LCD monitors are employed as display since the mobile terminal for video related services will most likely be equipped with LCD monitors.

B.3.1 Structure of test

B.3.1.1 Program

The subjective test is composed of several programs. A program is designed to be 20-40 minute long taking account of concentration duration of test subjects. A program is comprised of a training session followed by a scoring session. "Overtime" and "Australia" are handled separately in this level.

B.3.1.2 Training session

In order for test subjects to establish their own criteria on video subjective quality, a training session is tailored prior to actual evaluation. A training session consists of five video sequences, and there are two training sessions; one for "Overtime" and another for "Australia". These two are commonly used to every program in respective category. No score is put to sequences in a training session. A training session begins with 5-second indication notifying the beginning of the session. 5-second break is inserted between video sequences.

B.3.1.3 Scoring session

A scoring session is composed of multiple sequences, all of which are to be subjectively assessed. 10-second break is inserted between successive sequences. Test subject should mark a grade to a sequence during break which immediately follow the said sequence.

B.3.1.4 Video sequence

A video sequence, or sequence, represents a series of decoded images which is of 1-minute long.

B.3.1.5 Structure of program

A structure of a program is given in Table B5.

Session	Components	Contents	Duration [s]	Time elapsed
Training	Indication	training session	5	
	training #1	video sequence	60	
	Break	gray image	5	
	training #2	video sequence	60	
	Break	gray image	5	
	•••			
	training #5	video sequence	60	5'25"
Scoring	indication	scoring session	10	
	evaluation #1	video sequence	60	
	score and break	gray image	10	
	evaluation #2	video sequence	60	
	score and break	gray image	10	
	•••			
	evaluation #23*	video sequence	60	
score	gray image	10	32'25"	
Note	The total number of sequences in a scoring session ranges from 21 to 23 depending on program.			

Table B5: Structure of program

B.3.2 Editing process

The decoded video sequences submitted by experimenters are to be edited, i.e., re-organized complying with a simplified SS-5DQS method.

B.3.2.1 Producing training session

Five sequences, each for "Overtime" and "Australia", are to be picked up. Two extremes, one in the best quality class and one in the worst quality class shall be included in a training session. The other three are to be picked up covering various classes in video quality.

B.3.2.2 Randomization

"Overtime" and "Australia" sequences are dealt with separately, and those related programs are denoted like "O1" which represents the first program of "Overtime". Firstly the number of programs are determined taking account of the total number of sequences. Since there are 91 and 64 sequences for "Overtime" and "Australia", respectively, 4 programs for "Overtime" and 3 programs for "Australia" are generated. Secondly sequential number is put to sequences properly. Then video sequences are classified into those programs using random numbers.

B.3.3 Assessment

B.3.3.1 Test subjects

According to an ITU-R recommendation, reliable MOS data can be obtained with 10 expert test subjects or with 20 non-expert test subjects or more. In this test, 15 (12 experts, 1 semi-expert and 2 non-experts) and 14 (11 experts, 2 semi-experts and 1 non-expert) test subjects are employed for evaluation of Overtime and Australia sequences, respectively.

Time	Test Subject Group A	Test Subject Group B	Test Administrators
09:20 – 10:10			Equipment Set-up
10:10 – 10:30	Explanation of the Test		Preparation for O1
10:33 – 11:06	Evaluation (Program O1)	Break	
11:06 – 11:12	Break		Preparation for A1
11:12 – 11:44			Evaluation (Program A1)
11:44 – 11:52		Lunch Break	Preparation for O2
11:52 – 12:25	Evaluation (Program O2)		
12:25 – 13:00	Lunch Break		Preparation for A2•Lunch
13:00 – 13:33			Evaluation (Program A2)
13:33 – 13:40		Break	Preparation for O3
13:40 – 14:13	Evaluation (Program O3)		
14:13 – 14:20	Break		Preparation for A3
14:20 – 14:53			Evaluation (Program A3)
14:53 – 15:00		Dismissal (after above)	Preparation for O4
15:00 – 15:33	Evaluation (Program O4)		
	Dismissal (after above)		
15:33 – 16:00			Equipment Take-down

Table B6: Time schedule of test

B.3.3.2 Facilities and equipment for test

As many as 15 test subjects shall conduct the evaluation at the same time in the subjective test. From among several possible solutions the following equipment is deployed for the test. One set capable of handing four LCD monitors (including one parent PC) is composed of; 1) one high-performance PC, 2) one Dsub15-to-BNC video interface (Umezawa, ITF-400), 3) one 1BNC-to-3BNC video splitter (Umezawa, UM-4700A), 4) three BNC-to-Dsub15 conversion boxes (Umezawa, ADA-400) and 5) three LCD monitors. Given that two test subjects share an LCD, two sets of above are necessary and can synchronously display video on up to 8 LCDs (including two parent PCs).

B.3.3.3 Score sheet

Score sheet is made on a program basis, and given to test subjects prior to each program. The format of score sheet is depicted in Figure B3, which exemplifies the case of "A1-01" marked "Good" and "A1-02" marked "Fair".

No.	Excellent	Good	Fair	Poor	Bad
A1-01		✓			
A1-02			✓		

Figure B3: Format of score sheet (example of "A1-01" marked "Good" and "A1-02" marked "Fair")

The following instruction is described on a score sheet; "Test subject shall subjectively judge how well quality of video sequence meets the quality test subject expects for IMT-2000 real time video communication services assumed. The best and worst quality sequences don't necessarily correspond to the grades excellent and bad, respectively."

B.3.4 Data processing

MOS (mean opinion score) and its standard deviation denoted by σ_{os} are calculated and to be reported as subjective test results.

B.3.4.1 MOS [%4.2f]

Let M and $OS[i]$ denote the number of test subjects and the opinion score of i -th test subject. Note that $OS[i]$ is associated with integers as below and so converted.

Excellent: 5 / Good: 4 / Fair: 3 / Poor: 2 / Bad: 1

Now the MOS is calculated as;

$$MOS = \sum_{i=1}^M \frac{OS[i]}{M}$$

B.3.4.2 Standard deviation of OS, i.e., σ_{os} [%4.2f]

The standard deviation of OS (opinion score) is expressed as;

$$\sigma_{os} = \sqrt{\sum_{i=1}^M \frac{(OS[i] - MOS)^2}{M - 1}}$$

B.4 Test results and observations

B.4.1 Test results

The test results including both opinion scores and statistical data are shown in the table of in chapter B6. Both the subjective test results and statistical data obtained through the simulation test are tabulated there in terms of channel type.

B.4.2 Observations

The characteristics of the residual errors on the simulated channels are considerably different from that of the ARIB IMT-2000 first video multimedia codec simulation test conducted in May-June 1998. The error density in the residual error burst is significantly lower this time probably due to the use of Turbo Codes [OBSERVE]. The effects of the used error correcting code, the residual error characteristic and its influence on the multimedia codec system have to be further investigated.

B.5 List of video/speech codecs and multiplexers employed in the simulation

Item	Sub-item	A	B	C	D	E	F
Video coding	Algorithm/profile	MPEG-4 Simple Profile	MPEG-4 Simple Profile	MPEG-4 Simple Profile	MPEG-4 Simple Profile	MPEG-4 Simple Profile	MPEG-4 Simple Profile
	tools/options	I-VOP P-VOP AC/DC Prediction Reversible VLC Slice Resynch Data Partitioning	I-VOP P-VOP AC/DC Prediction Reversible VLC Slice Resynch Data Partitioning	I-VOP P-VOP AC/DC Prediction Reversible VLC Slice Resynch Data Partitioning Header Extension Code used	I-VOP P-VOP AC/DC Prediction Reversible VLC Slice Resynch Data Partitioning Header Extension Code Used	I-VOP P-VOP AC/DC Prediction Reversible VLC Slice Resynch Data Partitioning Header Extension Code used	I-VOP P-VOP AC/DC Prediction Reversible VLC Slice Resynch Data Partitioning Header Extension Code used
	rate control	MPEG-2 TM-5 step2	used (variable frame rate)				ITU-T H.263 tmn8
Multiplexing	Algorithm/level	ITU-T H.223 Level 2/3	ITU-T H.223 Level 2	ITU-T H.223 Level 1/2 ^{*1}	ITU-T H.223 Level 3	ITU-T H.223 Level 2	ITU-T H.223 Level 2
	tools/options	optional header	optional header	optional header	optional header interleave (for Annex C)	no optional header	no optional header
Speech coding (dummy data)	Back channel model	N/A	N/A	N/A	N/A	N/A	N/A
	bit rate/frame length	6.4kbps/30ms	8.0kbps/20ms	4.0kbps/20ms 8.0kbps/10ms	7.67, 7.94, 8.09, 8.12kbps, /10ms	8.0kbps/30ms	6.4kbps/30ms
Video coding	Sub-item	G	H	I	J	K	L
	Algorithm/profile	H.263 Ver.2 Annexes: D, F, I, J, N, T	MPEG-4 Simple Profile	MPEG-4 Simple Profile	H.263 Ver.2 Annexes: D, F, N, R	MPEG-4 Simple Profile	MPEG-4 Simple Profile
	tools/options		I-VOP P-VOP AC/DC Prediction Reversible VLC Slice Resynch Data Partitioning	I-VOP P-VOP AC/DC Prediction Reversible VLC Slice Resynch Data Partitioning Header Extension Code	I-VOP P-VOP AC/DC Prediction Reversible VLC Slice Resynch Data Partitioning Header Extension Code	I-VOP P-VOP AC/DC Prediction Reversible VLC Slice Resynch Data Partitioning Header Extension Code	I-VOP P-VOP AC/DC Prediction Reversible VLC Slice Resynch Data Partitioning Header Extension Code
Multiplexing	rate control	ITU-T H.263 TMN 5	ITU-T H.263 TMN 5	TMN5	H.263 TMN-6	used	used
	Algorithm/level	ITU-T H.223 Level 2	ITU-T H.223 Level 2	ITU-T H.223 Level 3wRS	ITU-T H.223 Level 2	ITU-T H.223 Level 1/2 ^{*1}	ITU-T H.223 Level 2/3/3wRS
	tools/options	no optional header	no optional header	optional header	no optional header	optional header	optional header
Speech coding (dummy data)	Back channel model	H.245 videoFastUpdateGOB and videoFastUpdatePicture	H.245 videoFastUpdatePicture	N/A	H.263 Annex N separate logical channel mode ^{*2}	N/A	N/A
	bit rate/frame length	7.6kbps/20ms	7.6kbps/20ms	8.0kbps/20ms	6.4kbps/30ms	8.0kbps/10ms	6.4kbps/30ms
Note:	<p>*1: EI (error indication) is generated at AL3 and sent to video decoder together with video bitsream assuming AL-SDU is of fixed length and the length is known to both video encoder and decoder.</p> <p>*2: Error pattern of forward-channel is hypothetically applied to back-channel. The separate logical channel mode specified in H.223 Annex N option delivers the back-channel message through the dedicated logical channel. As to the delay due to the back-channel, it is almost zero at the codec, and is assumed to be the duration to transmit the maximum MUX-PDU considering the worst case at multiplexer.</p>						

B.6 Test results

Video Sequence	Channel type	subjective test results		experimenter's choice			statistical data at encoder/multiplexer							statistical data at decoder/de-multiplexer				
		MOS	\bullet_{os}	MUX	audio bitrate [kbps]	audio frame length [ms]	MUX overhead [kbps]	picture spatial resolution	video bitrate [kbps]	coding frame rate [frames/s]	video initial delay [ms]	out of delay constraints [%]	PSNR _{free} [dB]	PSNR _{total} [dB]	PSNR _{k*} [dB]	Sigma [dB]	average drop frame rate [%]	
Overtime	LinkRate-IL-BER	F32-10-3	2	4.00	20	4.01	QCIF	24.01	8.02	489.0	0.00	33.72	32.02	31.98	0.47	2.37		
			2	6.40	30	6.58	QCIF	19.02	8.40	591.6	0.02	31.86	31.34	31.35	0.09	0.00		
			2	4.00	20	4.01	QCIF	24.01	8.02	489.0	0.00	33.72	30.55	30.51	0.50	4.68		
	M32-10-3	2	4.00	20	4.01	QCIF	24.01	8.02	489.0	0.00	33.72	31.92	31.93	0.45	2.12			
		2	6.40	30	6.58	QCIF	19.02	8.34	591.6	0.02	31.86	30.92	30.91	0.15	0.00			
		2	6.40	30	2.60	QCIF	20.67	7.50	454.0	0.00	31.56	28.68	28.42	2.72	0.10			
	F32-20-4	2	4.00	20	4.01	QCIF	24.01	8.02	489.0	0.00	33.72	33.50	33.49	0.17	0.26			
		2	6.40	30	6.59	QCIF	19.01	8.47	591.6	0.03	31.86	31.78	31.78	0.05	0.00			
		2	6.40	30	2.60	QCIF	20.67	7.50	454.0	0.00	31.56	28.17	28.52	3.17	1.05			
	M32-20-4	2	4.00	20	4.01	QCIF	24.01	8.02	489.0	0.00	33.72	33.32	33.32	0.25	0.64			
		2	6.40	30	6.59	QCIF	19.01	8.46	591.6	0.03	31.86	31.71	31.71	0.08	0.00			
		2	6.40	30	3.17	QCIF	25.05	8.33	469.4	0.00	33.83	33.83	33.83	0.00	0.00			
F32-10-6	2	6.40	30	2.60	QCIF	20.69	7.50	454.0	0.00	31.57	31.56	31.56	0.04	0.00				
	2	6.40	30	6.59	QCIF	19.01	8.45	591.6	0.02	31.86	31.86	31.86	0.01	0.00				
	1	4.00	20	3.16	QCIF	25.03	10.58	469.4	0.00	33.15	33.15	33.15	0.01	0.01				
F32-80-6	2	6.40	30	2.60	QCIF	20.61	7.50	454.0	0.01	31.52	31.22	31.44	1.29	0.35				
	2	6.40	30	6.59	QCIF	19.01	8.45	591.6	0.06	31.86	31.85	31.86	0.02	0.00				
	1	4.00	20	3.17	QCIF	25.05	8.33	469.4	0.00	33.83	33.83	33.83	0.01	0.01				
M32-10-6	2	6.40	30	2.60	QCIF	20.69	7.50	454.0	0.00	31.57	31.56	31.56	0.04	0.00				
	2	6.40	30	6.59	QCIF	19.01	8.46	591.6	0.02	31.86	31.86	31.86	0.01	0.00				
	1	4.00	20	3.16	QCIF	25.03	10.58	469.4	0.00	33.15	33.15	33.15	0.01	0.02				
M32-80-6	2	6.40	30	2.60	QCIF	20.61	7.50	454.0	0.01	31.52	30.91	31.38	1.82	0.70				
	2	6.40	30	6.59	QCIF	19.01	8.45	591.6	0.06	31.86	31.85	31.86	0.03	0.00				
	2	8.00	20	3.20	QCIF	52.80	9.65	384.0	0.86	35.02	32.55	32.52	1.06	0.04				
F64-10-3	2	8.00	10	8.03	QCIF	48.06	11.63	475.0	0.00	35.40	33.90	33.89	0.29	2.66				
	2	7.60	20	7.06	QCIF	49.34	9.31	463.8	0.21	36.77	32.88	32.94	0.77	1.65				
	2	7.60	20	8.63	QCIF	47.77	9.11	482.8	0.43	34.90	32.86	32.85	0.46	1.96				
	2	6.40	30	6.56	QCIF	51.04	9.06	300.4	0.00	36.04	34.87	34.86	0.19	0.00				
	2	6.40	30	5.08	QCIF	46.88	7.48	582.0	0.01	31.58	28.54	28.28	1.34	0.70				
	3	8.12	10	32.65	QCIF	24.27	6.25	599.0	11.47	33.39	31.86	31.85	0.60	6.99				

Video Sequence	Channel type	subjective test results		experimenter's choice			statistical data at encoder/multiplexer							statistical data at decoder/de-multiplexer				
		MOS	\bullet_{os}	MUX	audio bitrate [kbps]	audio frame length [ms]	MUX overhead [kbps]	picture spatial resolution	video bitrate [kbps]	coding frame rate [frames/s]	video initial delay [ms]	out of delay constraints [%]	PSNR _{free} [dB]	PSNR _{total} [dB]	PSNR _{k*} [dB]	Sigma [dB]	average drop frame rate [%]	
M64-10-3	LinkRate-IL-BER	1.40	0.51	3	6.40	30	20.10	QCIF	34.07	7.42	561.3	0.07	30.69	28.11	28.46	1.31	0.29	
		1.60	0.63	3wRS	6.40	30	20.33	QCIF	34.07	7.42	561.3	0.07	30.69	28.41	28.39	1.33	0.30	
		1.87	0.64	2	8.00	20	3.20	QCIF	52.80	9.65	384.0	1.21	35.02	30.99	30.89	1.00	0.00	
		1.53	0.52	2	8.00	10	8.03	QCIF	48.06	11.63	475.0	0.00	35.40	32.91	32.90	0.28	4.99	
		1.33	0.49	2	7.60	20	7.04	QCIF	49.36	9.30	463.5	0.22	36.77	31.57	31.55	0.83	2.80	
		1.13	0.35	2	7.60	20	8.53	QCIF	47.87	9.14	465.4	0.41	34.90	31.08	30.97	1.13	3.03	
		1.60	0.51	2	6.40	30	6.56	QCIF	51.04	9.06	300.4	0.00	36.04	34.20	34.20	0.15	0.00	
		1.47	0.64	2	6.40	30	5.08	QCIF	46.88	7.48	582.0	0.01	31.58	25.90	25.42	1.49	1.25	
		1.60	0.63	3	8.12	10	32.65	QCIF	24.27	6.25	599.0	11.47	33.39	31.85	31.89	0.55	6.89	
		1.27	0.59	3	6.40	30	20.10	QCIF	34.07	7.42	561.3	0.07	30.69	26.31	26.68	1.36	0.46	
		1.40	0.51	3wRS	6.40	30	20.33	QCIF	34.07	7.42	561.3	0.07	30.69	27.77	28.17	1.29	0.48	
		3.33	0.62	2	8.00	20	3.20	QCIF	52.80	9.65	384.0	1.21	35.02	34.60	34.54	0.66	0.00	
		2.87	0.92	2	8.00	10	8.03	QCIF	48.06	11.63	475.0	0.00	35.40	35.20	35.20	0.13	0.31	
		3.67	0.72	2	8.00	30	7.35	QCIF	48.07	10.40	545.3	1.44	38.74	37.58	37.41	0.81	0.06	
		2.93	0.88	2	7.60	20	6.84	QCIF	49.56	9.38	461.6	0.18	36.77	35.25	35.24	0.36	0.19	
2.87	0.83	2	7.60	20	8.17	QCIF	48.23	9.23	473.6	0.33	34.90	34.40	34.38	0.78	0.47			
3.47	0.64	2	6.40	30	6.57	QCIF	51.03	9.05	300.4	0.00	36.04	35.89	35.89	0.09	0.00			
3.40	0.74	2	6.40	30	5.08	QCIF	46.88	7.48	582.0	0.04	31.58	31.38	31.37	0.40	0.14			
2.73	0.70	3	6.40	30	24.60	QCIF	32.39	7.50	325.0	0.00	33.87	31.32	32.81	3.18	2.80			
2.80	0.68	3	8.12	10	32.50	QCIF	24.25	6.30	598.3	11.38	33.45	33.38	33.39	0.14	1.44			
2.53	0.52	3	6.40	30	19.30	QCIF	33.00	7.40	561.3	0.11	30.83	30.70	30.67	0.39	0.06			
2.60	0.63	3wRS	6.40	30	19.70	QCIF	33.00	7.40	561.3	0.11	30.83	30.81	30.81	0.14	0.00			
2.73	0.88	2	8.00	20	3.20	QCIF	52.80	9.65	384.0	2.76	35.02	34.21	34.25	0.82	0.00			
3.07	0.88	2	8.00	10	8.03	QCIF	48.06	11.63	475.0	0.00	35.40	35.05	35.07	0.15	0.69			
3.33	0.72	2	8.00	30	7.35	QCIF	48.07	10.40	545.3	1.44	38.74	36.08	36.24	1.75	0.17			
2.73	0.70	2	7.60	20	6.95	QCIF	49.45	9.35	462.7	0.18	36.77	34.75	34.74	0.81	0.35			
3.20	1.01	2	7.60	20	8.90	QCIF	47.50	9.08	485.6	0.35	34.90	34.32	34.35	0.22	0.72			
3.40	0.74	2	6.40	30	6.56	QCIF	51.04	9.05	300.4	0.00	36.04	35.73	35.74	0.09	0.00			
3.20	0.94	2	6.40	30	5.08	QCIF	46.88	7.48	582.0	0.04	31.58	30.64	30.81	1.05	0.19			
2.60	0.51	3	6.40	30	24.60	QCIF	32.39	7.50	325.0	0.00	33.87	29.69	29.27	3.17	4.95			
2.80	0.77	3	8.12	10	32.50	QCIF	24.25	6.30	598.3	11.38	33.45	33.22	33.19	1.88	2.20			

Video Sequence	Channel type	subjective test results		experimenter's choice			statistical data at encoder/multiplexer							statistical data at decoder/de-multiplexer			
		MOS	• _{os}	MUX	audio bitrate [kbps]	audio frame length [ms]	MUX overhead [kbps]	picture spatial resolution	video bitrate [kbps]	coding frame rate [frames/s]	video initial delay [ms]	out of delay constraints [%]	PSNR _{free} [dB]	PSNR _{total} [dB]	PSNR _{k*} [dB]	Sigma [dB]	average drop frame rate [%]
F64-10-6	LinkRate-IL-BER	2.07	0.96	3	6.40	30	19.30	QCIF	33.00	7.40	561.3	0.11	30.83	30.57	30.60	0.43	0.10
		2.87	0.74	3wRS	6.40	30	19.70	QCIF	33.00	7.40	561.3	0.11	30.83	30.72	30.71	0.28	0.01
		3.67	0.82	1	8.00	10	6.31	QCIF	50.04	15.63	490.2	0.00	34.42	34.35	34.35	0.00	0.01
		3.60	0.99	2	8.00	20	3.20	QCIF	52.80	9.65	384.0	0.86	35.02	35.02	35.02	0.01	0.03
		4.40	0.83	2	7.60	20	7.04	QCIF	49.37	9.53	500.8	0.17	36.77	36.73	36.74	0.09	0.00
		3.87	1.06	2	7.60	20	8.17	QCIF	48.23	9.23	461.9	0.32	34.90	34.84	34.85	0.09	0.29
		3.47	0.99	2	6.40	30	6.56	QCIF	51.04	9.05	300.4	0.00	36.04	36.04	36.04	0.01	0.00
		3.20	0.77	3	6.40	30	24.60	QCIF	32.41	7.50	325.0	0.00	33.88	33.52	33.88	1.64	0.35
		3.67	0.72	3	8.12	10	17.28	QCIF	39.50	6.53	530.5	8.42	36.49	36.49	36.49	0.03	0.00
		3.60	0.91	1	8.00	10	6.31	QCIF	50.04	15.63	490.2	0.00	34.42	34.35	34.35	0.01	0.01
		3.67	0.90	2	8.00	20	3.20	QCIF	52.80	9.65	384.0	9.67	35.02	35.01	35.02	0.05	0.01
		4.33	0.82	2	7.60	20	6.81	QCIF	49.59	9.58	498.5	1.67	36.77	36.65	36.65	0.17	0.12
3.93	0.80	2	7.60	20	8.45	QCIF	47.95	9.17	470.0	5.08	34.90	34.83	34.82	0.09	0.35		
3.73	0.70	2	6.40	30	6.57	QCIF	51.03	9.05	300.4	0.00	36.04	36.03	36.04	0.03	0.00		
2.60	0.63	3	6.40	30	24.60	QCIF	32.33	7.50	325.0	0.03	33.84	33.84	33.84	0.01	0.00		
4.07	0.59	3	7.94	10	16.28	QCIF	39.30	6.65	518.6	16.79	36.31	36.31	36.31	0.00	0.00		
3.53	0.99	1	8.00	10	6.31	QCIF	50.04	15.63	490.2	0.00	34.42	34.35	34.35	0.01	0.01		
4.40	0.83	2	8.00	20	3.20	QCIF	52.80	9.65	384.0	1.21	35.02	35.02	35.02	0.02	0.00		
4.33	0.72	2	7.60	20	6.95	QCIF	49.45	9.55	499.9	0.17	36.77	36.74	36.73	0.07	0.01		
3.87	0.74	2	7.60	20	8.67	QCIF	47.73	9.13	472.5	0.28	34.90	34.83	34.82	0.07	0.28		
3.87	0.74	2	6.40	30	6.57	QCIF	51.03	9.05	300.4	0.00	36.04	36.04	36.03	0.01	0.00		
3.13	0.74	3	6.40	30	24.60	QCIF	32.41	7.50	325.0	0.00	33.88	33.52	33.88	1.64	0.35		
3.67	0.90	3	8.12	10	17.28	QCIF	39.50	6.53	530.5	8.42	36.49	36.46	36.46	0.08	0.00		
3.33	0.90	1	8.00	10	6.31	QCIF	50.04	15.63	490.2	0.00	34.42	34.35	34.35	0.02	0.02		
3.60	0.99	2	8.00	20	3.20	QCIF	52.80	9.65	384.0	56.13	35.02	35.01	35.01	0.05	0.00		
3.67	0.72	2	7.60	20	6.85	QCIF	49.55	9.58	498.9	1.47	36.77	36.37	36.29	0.65	0.02		
3.80	0.94	2	7.60	20	8.39	QCIF	48.01	9.17	481.2	5.14	34.90	34.78	34.78	0.18	0.35		
3.87	0.99	2	6.40	30	6.57	QCIF	51.03	9.05	300.4	0.00	36.04	36.01	36.03	0.05	0.00		
2.53	0.64	3	6.40	30	24.60	QCIF	32.33	7.50	325.0	0.03	33.84	33.84	33.84	0.01	0.00		
4.00	0.93	3	7.94	10	16.28	QCIF	39.30	6.65	518.6	16.79	36.31	36.30	36.30	0.02	0.00		
1.21	0.43	2	6.40	30	4.65	CIF	52.38	6.45	389.0	0.0	33.49	29.40	29.99	2.00	1.52		

Australia

Video Sequence	Channel type	subjective test results		experimenter's choice		statistical data at encoder/multiplexer							statistical data at decoder/de-multiplexer			
		MOS	• _{os}	MUX	audio bitrate [kbps]	audio frame length [ms]	MUX overhead [kbps]	picture spatial resolution	video bitrate [kbps]	coding frame rate [frames/s]	video initial delay [ms]	out of delay constraints [%]	PSNR _{free} [dB]	PSNR _{total} [dB]	PSNR _{k*} [dB]	Sigma [dB]
M64-10-3	LinkRate-IL-BER	1.64	0.63	2	7.60	20	7.01	49.39	9.23	251.8	0.09	36.39	32.91	32.88	0.69	1.71
		1.50	0.52	2	7.60	20	8.32	48.08	9.13	228.8	0.23	35.05	32.31	32.31	1.14	1.89
		1.50	0.52	3	7.67	10	30.39	24.29	6.18	503.0	11.32	34.15	31.95	31.98	0.65	5.35
		1.93	0.62	3wRS	8.00	20	13.80	42.01	9.92	237.3	0.00	34.73	33.12	33.02	1.06	0.01
		1.21	0.43	2	6.40	30	4.72	52.40	6.43	388.9	0.0	33.48	27.75	27.95	1.49	3.76
		1.57	0.85	2	7.60	20	6.78	49.62	9.29	250.5	0.13	36.39	31.30	31.25	0.68	2.90
		1.57	0.65	2	7.60	20	8.37	48.04	9.13	225.5	0.24	35.05	30.52	30.58	1.34	4.51
		1.21	0.43	3	7.67	10	30.39	24.29	6.18	503.0	11.32	34.15	31.72	31.71	0.63	5.60
		1.57	0.65	3wRS	8.00	20	13.80	42.01	9.92	237.3	0.00	34.73	32.25	32.29	1.03	0.15
		2.07	0.62	2	6.40	30	4.68	52.39	6.53	389.0	0.00	33.59	33.11	33.12	0.40	0.15
		2.43	0.65	2	7.60	20	6.89	49.51	9.26	251.1	0.07	36.39	35.37	35.39	0.33	0.30
		2.43	0.65	2	7.60	20	8.17	48.23	9.15	228.0	0.33	35.05	34.35	34.56	1.01	0.60
2.50	0.52	2	8.00	10	8.00	48.29	9.80	441.8	1.36	36.88	34.09	34.14	1.92	0.40		
2.07	0.62	3	8.09	10	32.42	24.24	6.37	501.7	10.21	34.10	34.03	34.03	1.08	4.87		
2.64	0.63	3wRS	8.00	20	13.80	42.01	9.92	237.3	0.00	34.73	34.63	34.64	0.10	0.01		
1.79	0.58	2	6.40	30	4.71	52.36	6.45	389.2	0.00	33.58	32.53	32.54	0.76	0.34		
2.79	0.58	2	7.60	20	6.72	49.68	9.30	250.3	0.10	36.39	35.16	35.14	0.32	0.57		
2.43	0.51	2	7.60	20	8.42	47.98	9.13	229.2	0.18	35.05	34.38	34.38	0.41	0.79		
2.07	0.73	2	8.00	10	8.00	48.29	9.80	441.8	1.36	36.88	32.06	32.09	1.89	0.77		
1.93	0.73	3	8.09	10	32.42	24.24	6.37	501.7	10.21	34.10	33.91	33.91	1.35	6.24		
2.14	0.86	3wRS	8.00	20	13.80	42.01	9.92	237.3	0.00	34.73	34.52	34.51	0.14	0.05		
3.43	0.51	1	8.00	10	6.00	50.37	9.98	524.4	0.17	37.93	37.75	37.84	0.78	0.01		
3.29	0.61	2	7.60	20	6.86	49.54	9.27	250.9	0.11	36.39	36.22	36.23	0.23	0.18		
3.21	0.58	2	7.60	20	8.44	47.96	9.12	234.5	0.18	35.05	35.05	35.06	0.09	0.26		
2.43	0.51	3wRS	8.00	20	13.80	42.01	9.92	237.3	0.00	34.73	34.73	34.73	0.00	0.00		
3.36	0.63	1	8.00	10	6.00	48.52	9.82	544.5	5.94	37.79	37.74	37.79	0.16	0.00		
3.00	0.68	2	7.60	20	6.87	49.54	9.26	251.0	1.72	36.39	36.17	36.19	0.24	0.05		
2.93	0.62	2	7.60	20	8.10	48.30	9.17	235.7	4.46	35.05	35.05	35.05	0.08	0.46		
2.43	0.51	3wRS	8.00	20	13.80	42.01	9.92	237.3	0.00	34.73	34.73	34.73	0.00	0.00		
3.21	0.70	1	8.00	10	6.00	50.37	9.98	524.4	0.17	37.93	37.73	37.76	0.78	0.01		
3.21	0.70	2	7.60	20	6.75	49.65	9.29	250.4	0.10	36.39	36.29	36.29	0.13	0.01		

Video Sequence	Channel type	subjective test results		experimenter's choice			statistical data at encoder/multiplexer							statistical data at decoder/de-multiplexer			
		MOS	• _{os}	MUX H.223 Level	audio bitrate [kbps]	audio frame length [ms]	MUX overhead [kbps]	picture spatial resolution	video bitrate [kbps]	coding frame rate [frames/s]	video initial delay [ms]	out of delay constraints [%]	PSNR _{free} [dB]	PSNR _{total} [dB]	PSNR _{k*} [dB]	Sigma [dB]	average drop frame rate [%]
M64-80-6	LinkRate-IL-BER	2.79	0.58	2	7.60	20	8.29	QCIF	48.11	9.12	232.2	0.36	35.05	35.03	35.05	0.09	0.60
		2.57	0.65	3wRS	8.00	20	13.80	QCIF	42.01	9.92	237.3	0.00	34.73	34.73	34.73	0.00	0.00
		3.29	0.99	1	8.00	10	6.00	QCIF	48.52	9.82	544.5	5.94	37.79	37.54	37.51	0.56	0.03
		3.50	0.52	2	7.60	20	6.66	QCIF	49.75	9.31	249.9	2.99	36.39	36.17	36-23	0.37	0.10
		3.07	0.83	2	7.60	20	8.46	QCIF	47.94	9.12	232.9	4.86	35.05	35.02	35.01	0.09	0.32
		2.43	0.65	3wRS	8.00	20	13.80	QCIF	42.01	9.92	237.3	0.00	34.73	34.73	34.73	0.00	0.00
		2.36	0.50	2	8.00	20	5.60	CIF	114.40	7.42	394.0	1.57	34.65	31.72	31.42	2.25	0.00
		1.50	0.52	2	6.40	30	11.17	CIF	110.51	9.62	184.4	0.00	35.30	30.19	30.23	1.55	0.98
		2.14	0.53	3wRS	8.00	20	26.36	CIF	93.01	9.33	287.7	0.00	34.39	32.95	33.08	0.49	0.13
		1.57	0.51	2	8.00	20	5.60	CIF	114.40	7.42	394.0	2.02	34.65	30.06	29.82	1.62	0.00
		1.21	0.43	2	6.40	30	7.85	CIF	111.97	9.63	182.0	0.00	35.39	28.71	29.11	1.67	1.44
		1.64	0.50	3wRS	8.00	20	26.36	CIF	93.01	9.33	287.7	0.00	34.39	31.38	31.31	1.10	0.21
3.07	0.83	2	8.00	20	5.60	CIF	114.40	7.42	394.0	2.02	34.65	33.89	33.47	0.73	0.00		
2.57	0.51	2	6.40	30	7.86	CIF	112.03	9.73	181.9	0.00	35.48	34.52	34.54	0.39	0.11		
2.36	0.84	2	8.00	10	8.00	CIF	112.70	9.72	495.3	2.06	36.27	30.27	30.25	1.77	0.79		
3.36	0.84	3wRS	8.00	20	26.36	CIF	93.01	9.33	287.7	0.00	34.39	34.22	34.22	0.18	0.08		
2.79	0.70	2	8.00	20	5.60	CIF	114.40	7.42	394.0	6.74	34.65	33.43	33.16	0.68	0.00		
2.50	0.76	2	6.40	30	7.92	CIF	112.00	9.68	181.9	0.00	35.43	33.66	33.91	0.49	0.21		
1.36	0.50	2	8.00	10	8.00	CIF	112.70	9.72	495.3	2.06	36.27	28.23	28.23	2.02	1.68		
3.36	0.74	3wRS	8.00	20	26.36	CIF	93.01	9.33	287.7	0.00	34.39	34.01	34.01	0.23	0.12		
4.07	0.62	1	8.00	10	6.00	CIF	114.67	9.62	486.7	2.08	36.77	36.55	36.71	0.68	0.01		
3.86	0.77	2	8.00	20	5.60	CIF	114.40	7.42	394.0	1.57	34.65	34.64	34.63	0.05	0.00		
3.50	0.65	3wRS	8.00	20	26.36	CIF	93.01	9.33	287.7	0.00	34.39	34.38	34.39	0.03	0.00		
4.00	0.78	1	8.00	10	6.00	CIF	108.33	9.63	515.3	7.61	36.56	36.03	35.93	1.37	0.04		
3.86	0.95	2	8.00	20	5.60	CIF	114.40	7.42	394.0	29.44	34.65	34.62	34.59	0.10	0.00		
3.29	0.73	3wRS	8.00	20	26.36	CIF	93.01	9.33	287.7	2.68	34.39	34.39	34.39	0.00	0.00		
3.93	1.00	1	8.00	10	6.00	CIF	114.67	9.62	486.7	2.08	36.77	36.52	36.71	0.70	0.01		
3.86	0.53	2	8.00	20	5.60	CIF	114.40	7.42	394.0	2.02	34.65	34.64	34.63	0.05	0.00		
3.29	0	3wRS	8.00	20	26.36	CIF	93.01	9.33	287.7	0.00	34.39	34.38	34.39	0.03	0.00		
4.57	0.65	1	8.00	10	6.00	CIF	108.33	9.63	515.3	7.61	36.56	35.04	34.98	2.48	0.09		
3.64	0.50	2	8.00	20	5.60	CIF	114.40	7.42	394.0	91.69	34.65	34.61	34.61	0.10	0.00		

Video Sequence	Channel type	subjective test results		experimenter's choice			statistical data at encoder/multiplexer							statistical data at decoder/de-multiplexer				
		MOS	• _{os}	MUX	audio bitrate [kbps]	audio frame length [ms]	MUX overhead [kbps]	picture spatial resolution	video bitrate [kbps]	coding frame rate [frames /s]	video initial delay [ms]	out of delay constraints	PSNR _{free} [dB]	PSNR _{total} [dB]	PSNR _{k*} [dB]	Sigma [dB]	average drop frame rate [%]	
	LinkRate-IL-BER	3.57	0.65	H.223 Level 3wRS	8.00	20	26.36	CIF	93.01	9.33	287.7	2.68	34.39	34.39	34.39	0.00	0.00	

Annex C

[Ed note. The bulk of the Control related information.]

Annex D

[Ed note. The bulk of the Data related information.]

History

Document history		
V 0.0.1	April 19	First Draft
V 0.0.2	June 15	Revised per TSG SA S4#5 discussion
V 1.0.0	June 16	Approved per TSG SA #4 plenary