

TS 26.112 V.1.0.0 (1999-04)

Technical Specification

**3rd Generation Partnership Project (3GPP);
Technical Specification Group (TSG) Codec Working Group;
Codec(s) for Circuit Switched Multimedia Telephony Service
Call Set-up Requirements**

3GPP

Reference

<Work Item> (<Shortfilename>.PDF)

Keywords

circuit switched, codec, call setup, H.324, low
bitrate multimedia

3GPP

Postal address

Office address

Internet

secretariat@3gpp.org
Individual copies of this deliverable
can be downloaded from
<http://www.3gpp.org>

Copyright Notification

No part may be reproduced except as authorized by written permission.
The copyright and the foregoing restriction extend to reproduction in all media.

©
All rights reserved.

Contents

Intellectual Property Rights	4
Foreword	4
Introduction	4
1 Scope	5
2 References	5
3 Definitions, symbols and abbreviations	6
3.1 Definitions	6
3.2 Abbreviations	6
4. General	8
4.1 Use of BC and LLC Information Elements	8
4.2 Use of QoS parameters in BC Information Element	8
5. Call Set-up Scenarios	9
5.1 H.324 Call Set-up Between Two 3G Terminals	9
5.2 H.324 Call Set-up between 3G Terminal and a PSTN Multimedia Terminal	10
5.2.1 Mobile terminated call	10
5.2.2 Mobile originated call	14
5.3 H.324 Call Set-up between 3G Terminal and a N-ISDN Multimedia Terminal (H.324 Annex D)	15
5.3.1 Mobile originated call	15
5.3.2 Mobile terminated call	16
6 Effect of Gateways for Call Set-up	17
History	18

Intellectual Property Rights

TBD

Foreword

This Technical Specification has been produced by the 3rd Generation Partnership Project, Technical Specification Group Services and System Aspects, Working Group 4 (Codec).

The contents of this TS may be subject to continuing work within the 3GPP and may change following formal TSG approval. Should the TSG modify the contents of this TS, it will be re-released with an identifying change of release date and an increase in version number as follows:

Version m.t.e

where:

- m indicates [major version number]
 - x the second digit is incremented for all changes of substance, i.e. technical enhancements, corrections, updates, etc.
 - y the third digit is incremented when editorial only changes have been incorporated into the specification.
-

Introduction

Considering the global environment where the multimedia services are to be applied, several call set-up scenarios are possible for circuit switched H.324 multimedia service. A significant part of the H.324 calls will be between two 3GPP terminals. Other currently identified call scenarios are between 3G-PSTN, 3G-ISDN and 3G-IP.

The H.245 [7] is a control protocol that is common between the different multimedia systems V.70, H.310, H.323 and H.324. The control protocol is run on the logical control channel and is used for example to negotiate master/slave configuration, bit rate, codecs to be used, to measure the round trip delay, logical channels to be used and the type of each logical channel. H.245 procedures are executed after successful call set-up and are not covered in detail in this specification.

In all call set-up scenarios of this specification, it is assumed that H.324 service related bitstream descriptor H.223/H.245 is indicated in the BC IE and the LLC IE in the 04.08 [13] set-up message. This is further analysed in a separate section in clause 4 of this specification.

In some interworking scenarios a gateway is possible. This can then be, e.g., a gateway as described in H.246 [8] possibly with less or more functions. The 3G H.324 – IP scenario is such and suggested procedures are FFS in other 3GPP specifications. Effect of gateways for call control is handled in Clause 6 of this specification.

1 Scope

This technical specification describes the call-set-up requirements and related circuit switched call control procedures for ITU-T H.324 based multimedia service within GSM/3GPP networks and with external telecommunications networks.

2 References.

The following documents contain provisions which, through reference in this text, constitute provisions of the present document.

- References are either specific (identified by date of publication, edition number, version number, etc.) or non-specific.
- For a specific reference, subsequent revisions do not apply.
- For a non-specific reference, the latest version applies.
- A non-specific reference to an ETS shall also be taken to refer to later versions published as an EN with the same number.

- [1] 3GPP 26.110: "Codec(s) for Circuit Switched Multimedia Telephony Service; General Description".
- [2] ITU-T Recommendation H.324: "Terminal for low bit-rate multimedia communication".
- [3] ITU-T Recommendation H.223: "Multiplexing protocol for low bit rate multimedia communication".
- [4] ITU-T Recommendation H.223 - Annex A: "Multiplexing protocol for low bit rate multimedia communication - Annex A: Multiplexing protocol for low bit rate multimedia mobile communication over low error-prone channels".
- [5] ITU-T Recommendation H.223 - Annex B: "Multiplexing protocol for low bit rate multimedia communication - Annex B: Multiplexing protocol for low bit rate multimedia mobile communication over moderate error-prone channels".
- [6] ITU-T Recommendation H.223 - Annex C: "Multiplexing protocol for low bit rate multimedia communication - Annex C: Multiplexing protocol for low bit rate multimedia mobile communication over highly error-prone channels".
- [7] ITU-T Recommendation H.245: "Control protocol for multimedia communication".
- [8] ITU-T Recommendation H.246: "Interworking of H-Series multimedia terminals with H-Series multimedia terminals and voice/voiceband terminals on GSTN and ISDN".
- [9] ITU-T Recommendation V.8: "Procedures for starting sessions of data transmission over the public switched telephone network".
- [10] ITU-T Recommendation V.8bis: "Procedures for the identification and selection of common modes of operation between data circuit-terminating equipment (DCEs) and between data terminal equipment (DTEs) over the general public switched telephone network and on leased point-to-point telephone-type circuits".
- [11] ITU-T Recommendation V.140: "Procedures for establishing communication between two multiprotocol audio-visual terminals using digital channels at a multiple of 64 or 56 kbit/s".
- [12] ITU-T Recommendation Q.931: "Digital subscriber signalling system no. 1 (DSS1) – ISDN user-network interface layer 3 specification for basic call control".
- [13] GSM 04.08: "Digital cellular telecommunications system (Phase 2+); Mobile radio interface layer 3 specification".
- [14] GSM 07.01: "Digital cellular telecommunications system (Phase 2+); General on Terminal Adaptation Functions (TAF) for Mobile Stations (MS)".
- [15] GSM 09.07: "Digital cellular telecommunications system (Phase 2+); General requirements on interworking between the Public Land Mobile Network (PLMN) and the Integrated Services Digital Network (ISDN) or Public Switched Telephone Network (PSTN)".
- [16] GSM 02.02: "Digital cellular telecommunications system (Phase 2+); Bearer Services (BS) supported by a GSM Public Land Mobile Network (PLMN)".

3 Definitions, symbols and abbreviations

3.1 Definitions.

For the purposes of the present document, the terms and definitions apply.

bearer capability information: Specific information defining the lower layer characteristics required within the network.

low layer compatibility information: Information defining the lower layer characteristics of the terminal.

high layer compatibility information: Information defining the higher layer characteristics of the terminal.

compatibility information: This term subsumes the entirety of Bearer Capability, Low Layer Compatibility, High Layer Compatibility, Progress Indicator and Address Information conveyed out-of-band prior to call establishment for the support of compatibility checking and terminal/function/service selection at the ISDN-type user-network interface.

progress indicator: Information supplied to indicate to the terminal that network interworking has taken place.

out-of-band parameter exchange: Information exchanged via an associated or non-associated signalling link e.g. SS No 7.

PSTN: Subscriber to network interface supports only analogue terminals.

ISDN: Subscriber to network interface supports digital or analogue terminals, plus a standardised user to network associated signalling system and a standardized internetwork signalling system.

3G H.324 terminal: a H.324 terminal following the specifications stated in [1], utilising mobile adaptations of the multiplexing layer in ITU-T H.223 [3] (i.e. H.223 Annex A [4], B [5] and C [6]) is hereafter referenced in this specification as 3G H.324 terminal for simplicity. Those mobile adaptations may or may not be used in non-3G H.324 terminals – the in-band peer-to-peer multiplex level exchange is outside the scope of this specification.

ANSam: Answer sinewave signal at 2100 Hz, amplitude-modulated.

3.2 Abbreviations.

For the purposes of the present document, the following abbreviations apply:

ACM	Address Complete Message
ANM	Answer Message
BC	Bearer Capability
BS	Bearer Service
CE	Connection Element
CF	Call Function
CI	Call Indicator
CM	Call Menu
CPG	Call Progress
DCE	Data Circuit Equipment
DSS1	Digital Subscriber Signalling 1
DTE	Data Terminating Equipment
FFS	For Further Study
FNUR	Fixed Network User Rate
GSTN	Ground Switched Telecommunications Network
HLR	Home Location Register
IAM	Initial Address Message
IE	Information Element
IP	Internet Protocol
ISDN	Integrated Services Digital Network
ISUP	Integrated Services User Part
ITC	Information Transfer Capability
IWF	Interworking Function
JM	Joint Menu
LE	Local Exchange
LLC	Low Layer Compatibility
MS	Mobile Station
MSC	Mobile Switching Centre
N-ISDN	Narrow-band ISDN
PLMN	Public Land switched Mobile Network
PSTN	Public Switched Telephone Network
SVD	Simultaneous Voice and Data
UDI	Unrestricted Digital Information

UI_L1	User Information Layer 1 Protocol
UTRAN	UMTS Terrestrial Radio Access Network
WAIUR	Wanted Air Interface User Rate
VLR	Visitor Location Register

4. General

The purpose of this Technical Specification is to state the required call set-up procedures for setting up H.324 circuit switched multimedia calls to and from 3GPP terminals that exploit the call control specified in 3GPP (TS 24.08?). The below chapters include so far identified circuit switched domain interworking scenarios, and explain in detail the call set-up process with illustrated call set-up message flows. More interworking scenarios may be needed in later versions of this technical specification and corresponding call set-up descriptions shall be introduced as necessary. Implementation of some novel features explained in the specification are still for further study, as they require changes in related 3GPP CC specifications. Clarifications may also be required in external multimedia standards, such as mandating a compatible H.324 Annex D call setup procedure. To start the discussion in the baseline specification, the paragraph 4.1 lists identified options.

4.1 Use of BC and LLC Information Elements

This specification is assuming that the 3GPP call control will be an evolved version of GSM 04.08 call control specification. All references to 04.08 in the following specification text and message flows refer to the 3GPP version until the TS number can be changed to the appropriate one (24.08?). To enable a well-defined call set-up for the 3G H.324 service over mobile networks, the 3GPP CC needs minor additions. These additions are explained below. In Q.931 [12] information elements there exists one additional coding point originally added to signal H.324 Annex D usage over ISDN, which is needed and should be included to 3GPP signalling. This coding point is User information layer 1 protocol (octet 5) and is described below as an extract from [12]:

User information layer 1 protocol (octet 5)

Bits

54321

00001 CCITT standardized rate adaptation V.110, I.460 and X.30. This implies the presence of octet 5a and optionally octets 5b, 5c and 5d as defined below.

00010 Recommendation G.711 μ -law

00011 Recommendation G.711 A-law

00100 Recommendation G.721 32 kbit/s ADPCM and Recommendation I.460.

00101 Recommendations H.221 and H.242

00110 Recommendations H.223 and H.245

00111 Non-ITU-T standardised rate adaptation. This implies the presence of octet 5a and, optionally, octets 5b, 5c and 5d. The use of this code point indicates that the user rate specified in octet 5a is defined by the user.

Additionally, octets 5b, 5c and 5d, if present, are defined consistent with the user specified rate adaptation.

01000 ITU-T standardised rate adaptation V.120. This implies the presence of octets 5a and 5b as defined below, and optionally octets 5c and 5d.

01001 CCITT standardised rate adaptation X.31 HDLC flag stuffing.

All other values are reserved.

It may be possible to include the H.223/H.245 option in the User Information Layer 1 attribute in the Low Layer Compatibility information element of GSM 04.08. This would align 04.08 with Q.931 where it is already included. GSM 04.08 refers to an old ETSI standard for LLC but then 24.08 can be changed to refer to Q.931 instead. LLC IE is used in peer-to-peer communication and its values are not used/checked by the mobile switching centre.

It would be also required to add an H.223/H.245 option in the 04.08 Bearer Capability information element for information exchange between the mobile station and the mobile switching centre. One alternative could be to use User Information Layer 1 field. It is currently not used (0000 = default layer 1 protocol, other values reserved for future use). The Q.931 field contains five bits instead of four. An alternative can be to skip the most significant bit (bit 5) in Q.931 since it is always 0. The GSM/3GPP value for H.223/H.245 would then be 0110.

The mapping of User Information Layer 1 value for H.223/H.245 is then Q.931: 00110 \leftrightarrow 3GPP 04.08: 0110.

4.2 Use of QoS parameters in BC Information Element

As the actual QoS parameters to be included in the 3GPP call control are FFS, there are no parameters included yet in the included BC IE parameter values of tables 1,2,3 and 4 in clause 5. When the QoS parameters become stable, appropriate values should be assigned for circuit switched real-time service, and added to the tables of this technical specification.

5. Call Set-up Scenarios

This clause covers scenarios relevant to H.324 call set-up in 3GPP terminals. In addition to direct multimedia mode initiation, the H.324 specification [2] allows the option to start in telephony mode and then to change to H.324 multimedia mode. This option of voice call first feature requires a switching from a PLMN voice codec to a transparent multimedia channel. Appropriate call set-up signalling procedures and network element requirements are FFS.

5.1 H.324 Call Set-up Between Two 3G Terminals

This section defines the circuit switched multimedia call set-up for two terminals residing both within the 3G PLMN domain. Direct multimedia telephony mode selection is assumed. The involved functional elements are exposed in figure



1.

Figure 1. Connection architecture for MS-to-MS H.324 calls.

The originating 3G H.324 terminal initiates the call set-up procedure by sending via the MS an 04.08 SETUP message to the originating MSC/VLR. The 04.08 Bearer Capability Information Element (BC IE) shall include parameter values listed in table 1.

Table 1. Affected BC IE parameter values, MS-to-MS H.324 call

Information Transfer Capability	Unrestricted Digital Information
Duplex Mode	Full duplex
Sync/Async	Synchronous
Connection Element	Transparent
Wanted Air Interface User Rate	64 kbit/s*
Fixed Network User Rate	64 kbit/s*
User Information Layer 1	H.223/H.245 (to be standardised in 04.08)

* for example only, WAIUR & FNUR can be any available value over 32 kbit/s [1]. Final parameter in 3GPP BC IE may be named different. The QoS parameters (FFS) should be added to the tables when they become stable enough.

- In this case the 04.08 Bearer Capability is used to indicate 64 kbits/s bit transparent synchronous case described in GSM 07.01 [14]. Other suitable transparent synchronous data bearer services described in GSM 02.02 [16] can be requested to be used as well. To inform the MSC about the requested service type, User Information Layer 1 (octet 6) shall include the value to be standardised for H.223/H.245.
- The 04.08 LLC IE is used to indicate H.223/H.245 peer-to-peer. This makes the called 3G terminal activate its H.324 application when receiving the SETUP (LLC:H.223/H.245) message.

After the received 04.08 SETUP message the originating MSC/VLR sends an ISUP Initial Address Message (IAM) to the terminating MSC/VLR. ISUP signalling between the involved MSCs conveys the BC_IE and LLC information elements in the original SETUP message.

The terminating MSC, in turn, sends a 04.08 SETUP message towards the terminating MS associated with the subscriber number dialled. The SETUP message informs the MS of the incoming call and of a default call type of transparent UDI bearer service, with LLC/User Information Layer 1 capability value set to be H.223/H.245.

The MS responds to the network by sending a 04.08 CALL-CONFIRMED message after having checked the compatibility with the requested bearer capability. The included BC IE defines the bearer parameters and should be set as in table 1.

Then, the called MS sends an 04.08 ALERTING message to the terminating MSC informing it that ringing has started to the called subscriber and consequently the originating MSC connects the ringing tone to the calling subscriber. Finally, when the called terminal answers a 04.08 CONNECT message is sent from the terminating MS to the terminating MSC and then from the originating MSC to the MS that initiated the call.

The communication link is now established between the two 3G H.324 terminals. The peer-to-peer multiplexing level exchange can be executed and logical channels can be established using the H.245 open logical channel procedure. The detailed signalling flow is included in figure 2.

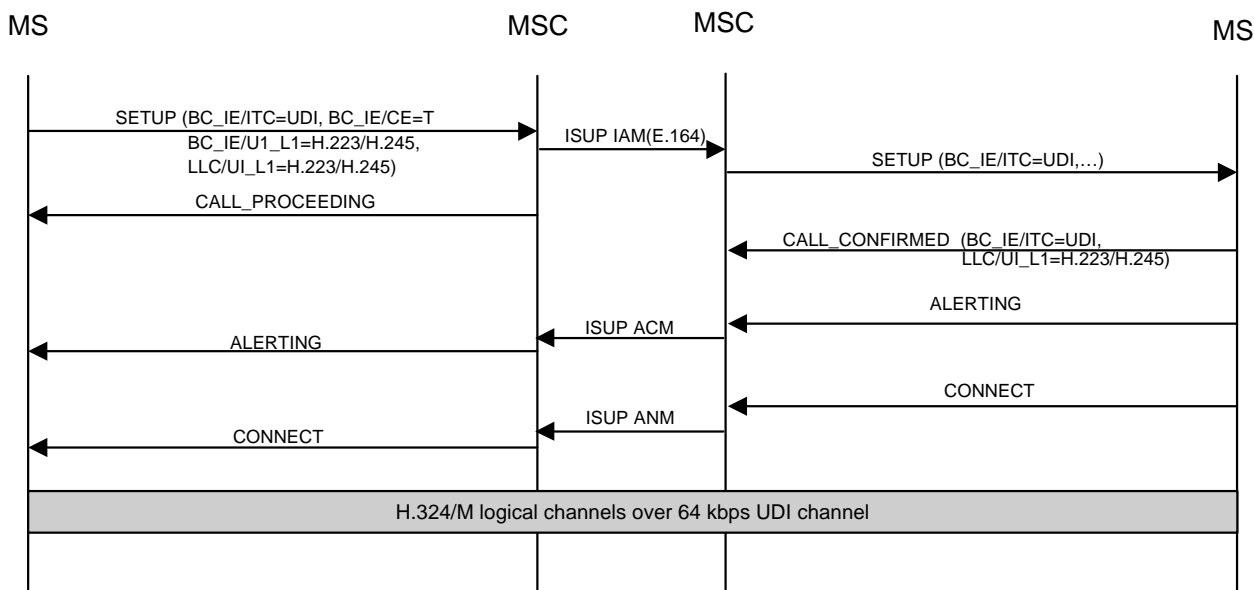

Figure 2. 3G-to-3G H.324 call set-up signalling

5.2 H.324 Call Set-up between 3G Terminal and a PSTN Multimedia Terminal

This section defines the call set-up between H.324 terminals residing one in 3G PLMN domain and another terminal in PSTN domain.

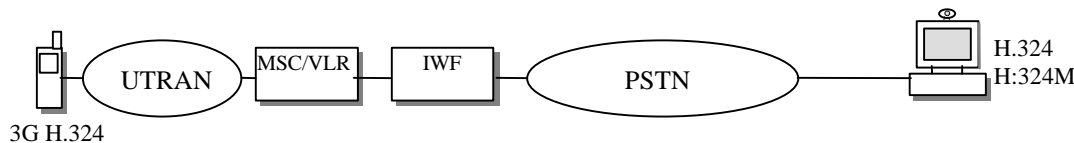

Figure 3. Connection architecture for 3G-to-PSTN/PSTN-to-3G H.324 calls.

To support voice call first feature of H.324 while interworking with PSTN, a simultaneous voice & data (SVD) type modem, which conforms to V.34 and V.8bis [10], is required in core network IWF.

5.2.1 Mobile terminated call

The two alternatives Multi-numbering Scheme and the Single-numbering Scheme (GSM 09.07 [15]) are available today in GSM to define what kind of service that is wanted for mobile terminated calls. Both cases are covered in this specification.

In the Multi-numbering Scheme separate E.164 numbers are allocated for different services and a separate number may be allocated for the H.324 multimedia. The criterion if Multi-numbering Scheme is used is that the HLR sends a GSM Bearer Capability in the Provide Roaming Number message. Thus, in mobile terminated case the IWF and MS can be informed that H.324 mode is wanted based on HLR register information linked to terminated MS E.164 number.

The modems in the IWF shall conform at least with H.324 related ITU-T V.8 [9], and preferably V.8bis signalling, so that it will detect and recognise the requested incoming call type from the V.8/V.8bis call function information category. In order to support interworking with PSTN H.324 terminals, the IWF modem shall conform to V.34, so as to support V.8. Conformance to the Simultaneous Voice and Data mode with V.8bis is optional to support H.324 voice call first feature. The DCE – modem - in MSC act as a signalling detector for detecting and interpreting V.8/V.8bis signalling, so that in-band signalling support is not required directly in the DTE, which in the mobile network is the 3G H.324 application in mobile terminal.

In both numbering schemes, after connection establishment, the involved IWF interprets and reports forward for the MSC's call control function the PSTN originated V.8/V.8bis signals.

- Originating PSTN H.324 terminal that uses V.8 only should send a V.8 CI (call indicator) message with value 0x21 according to the H.324 terminal procedure phase C. The IWF should then signal the H.324 capability in the V.8 JM (joint menu) call function octet.
- In case the PSTN H.324 calling station does not start V.8 signalling and the IWF does not support SVD mode, the IWF should act as a V.8bis non-telephony automatic answering station and should send a V.8bis MS (mode select) message specifying H.324 operation. If V.8bis is not supported in IWF modem, the IWF should start sending the V.8 ANSAM message as specified in [2].

The following subsections cover procedures with Multi-numbering and Single-numbering Schemes, respectively.

Multi-numbering Scheme

Figure 4 provides a call establishment signalling flow for an originating PSTN terminal to a terminating mobile station call using a Multi-numbering Scheme and assuming that H.324 voice call first is not supported by the IWF.

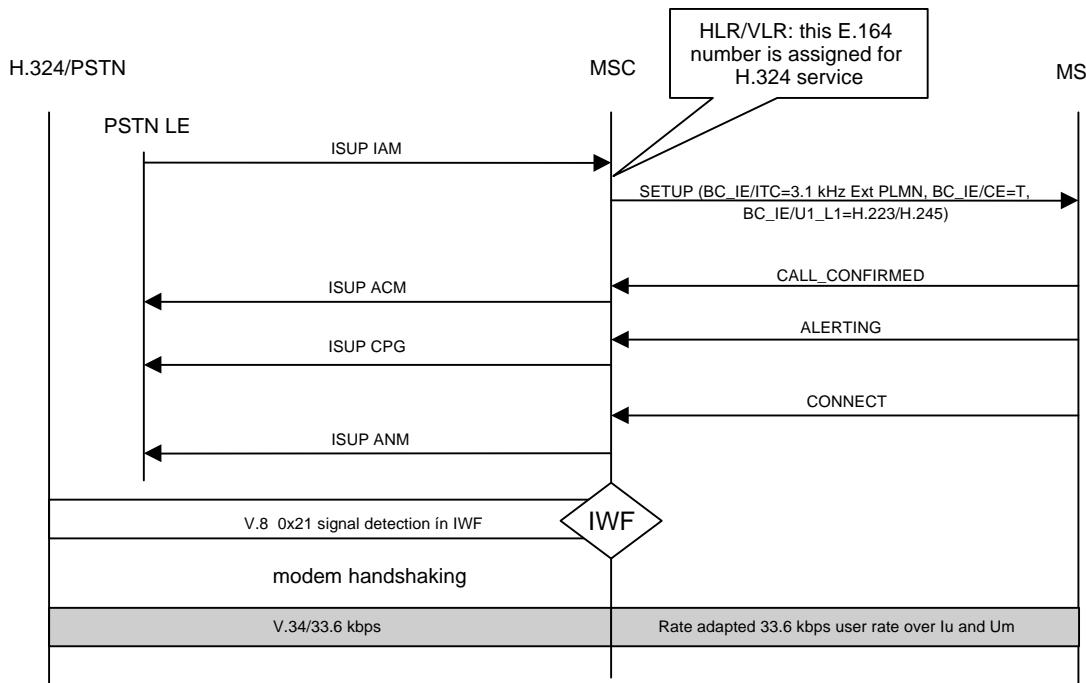

Figure 4. PSTN-to-3G H.324 call set-up signalling, Multi-numbering Scheme

At H.324 call set-up initiation from the PSTN terminal, an initial ISUP IAM message is sent from the PSTN local exchange (LE) to the MSC/VLR carrying the dialled subscriber number. The bearer capability information related to the subscriber number is fetched from the HLR/VLR as in existing GSM non-speech services.

The MSC then sends a 04.08 SETUP message to the MS associated with the subscriber number dialled. The BC IE shall include parameter values listed in table 2, the values are based on stored VLR/HLR register database information.

Table 2. Affected BC IE parameter values, mobile terminated H.324 call from PSTN

Information Transfer Capability	3.1 kHz Ex PLMN
Duplex Mode	Full duplex
Sync/Async	Synchronous
Connection Element	Transparent
Fixed Network User Rate	33.6 kbit/s*
Other Modem Type	V.34
User Information Layer 1	H.223/H.245

* Example only, highest currently specified V.34 speed

The MS responds by sending a 04.08 CALL-CONFIRMED message after having checked the compatibility with the requested bearer capability. If the MS or linked terminal does not support 3G H.324 application, call set-up will not continue and call attempt will fail. This acknowledgement message is forwarded to the PSTN LE by the MSC in ISUP message ACM.

Next, the MS sends an 04.08 ALERTING message to the MSC informing it that ringing has started to the called subscriber and consequently the MSC connects the ringing tone to the calling PSTN terminal subscriber via sending ISUP message CPG to the PSTN LE.

When the called terminal answers, a 04.08 CONNECT message is sent from the MS to the MSC, and ISUP message ANM sent by the MSC to the PSTN LE. A transparent data bearer according to requested bearer parameters is set up between the terminal and the MSC.

After reaching the connect phase the IWF modem is subject to start listening the V.8/V.8bis CI messages from the PSTN terminal.

- 1) Handling with V.8: A standard compliant PSTN H.324 application will send the V.8 CF code 0x21. The IWF should then signal the H.324 capability in the V.8 JM (joint menu) call function octet.
- 2) Handling with V.8bis: FFS, depending on whether to support H.324 voice call first.

IWF modem shall report successful mode detection for MSC's call control instance. The detected signalling is mapped into corresponding 04.08 signalling by the MSC (H.223/H.245 in User Information Layer 1 field, 33.6 kbits/s in FNUR, transparent bearer service category in CE, see table 2).

After successful detection of the V.8/V.8*bis*, the modems at MSC IWF and at PSTN H.324 terminal start the handshaking process, which ends up in connection with commonly agreed data modulation rate. The peer-to-peer multiplexing level exchange can then be executed and logical channels can be established using the H.245 open logical channel procedure.

Single-numbering Scheme

Figure 5 provides a call establishment signalling flow for an originating PSTN H.324 terminal towards a terminating mobile station call using a Single-numbering Scheme.

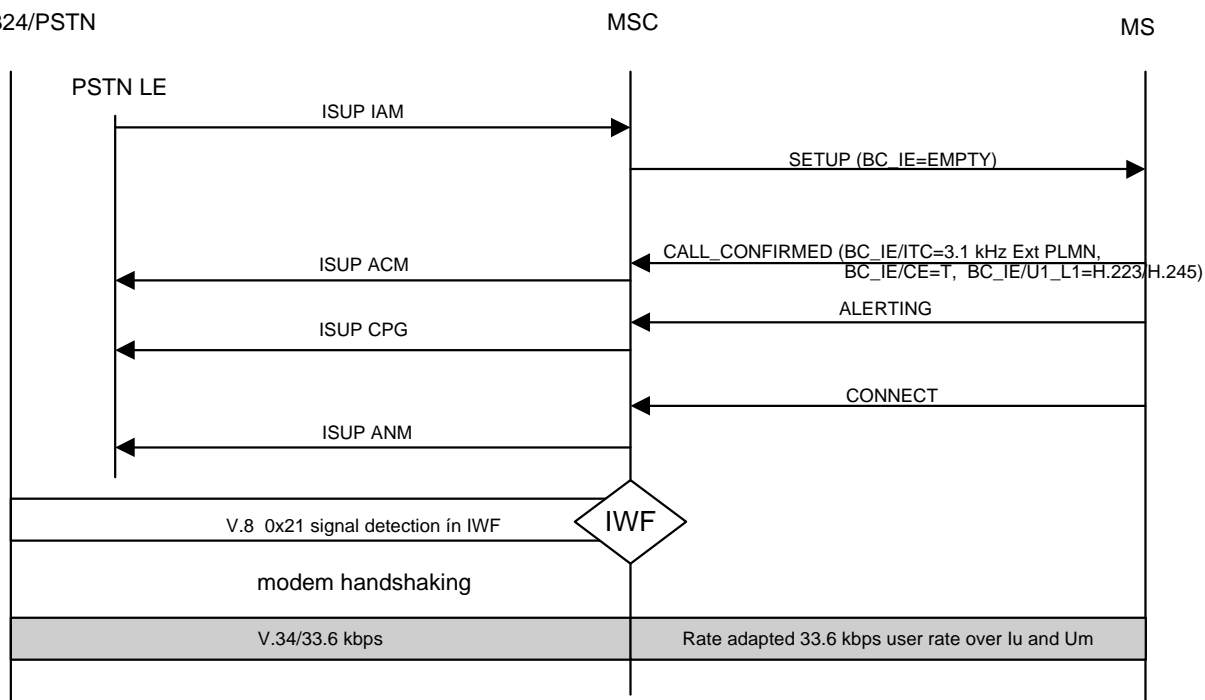

Figure 5. PSTN-to-3G H.324 call set-up signalling, Single-numbering Scheme

When a H.324 call originates from the PSTN terminal, an initial ISUP IAM message is sent from the PSTN local exchange to the MSC/VLR . The MSC, in turn, sends a 04.08 SETUP message to the MS associated with the subscriber number dialled. The SETUP message informs the MS of the incoming call; . in this PSTN originated case where detailed BC IE information is not available from PSTN local exchange, no BC IE is sent in the MSC-originated SETUP message.

The MS responds by sending a 04.08 CALL-CONFIRMED message after having checked the compatibility with the requested bearer capability. The included BC IE shall indicate if 3G H.324 service (among other capabilities, listed in preference order) is supported by the MS, triggering the required switching of the call via IWF in the MSC. This acknowledgement message is forwarded to the PSTN LE by the MSC in ISUP message ACM.

Then, the MS sends an 04.08 ALERTING message to the MSC informing it that ringing has started to the called subscriber and consequently the MSC connects the ringing tone to the calling PSTN terminal subscriber via sending ISUP message CPG to the PSTN LE.

When the called subscriber answers, a 04.08 CONNECT message is sent from the MS to the MSC, and ISUP message ANM sent by the MSC to the PSTN local exchange.

After reaching the connect phase the IWF modem is subject to start listening the V.8/V.8bis CI messages. The IWF shall identify from detected in-band V.8/V.8bis signalling the CF code values dedicated to PSTN multimedia terminal and reports these events towards MSC.

- 1) Handling with V.8: A standard compliant PSTN H.324 application will send the V.8 CF code 0x21. The IWF should then signal the H.324 capability in the V.8 JM (joint menu) call function octet.
- 2) Handling with V.8bis: FFS

The signalling is mapped into corresponding 04.08 signalling by the MSC (H.223/H.245 in User Information Layer 1 field, 33.6 kbit/s in FNUR, transparent bearer service category in CE, see table 2).

After successful detection of the V.8/V.8bis signalling expected by the IWF, the modems at MSC and in PSTN terminal shall start the handshaking process which ends up in connection with commonly agreed data modulation rate.

The connection is now established for multimedia communication between the PSTN terminal and MS. Communication takes place in 3.1 kHz (external to the PLMN) bearer service category [16] involving V.34 modem at the interworking function and using the optimised radio bearer over UTRAN.

The peer-to-peer multiplexing level exchange can be executed, and logical channels established using the H.245 open logical channel procedure. Support of the H.324 Annex C also in PSTN H.324 terminal will result in better user satisfaction due to increased error resilience, but cannot be mandated by 3GPP.

5.2.2 Mobile originated call

As in mobile terminated H.324 call set-up cases , The MSC IWF shall conform at least with H.324 relevant sections of V.8, and preferably V.8bis specifications, so that it can send and recognise a call type from the V.8/V.8bis call function information category.

If the voice call feature of H.324 is not to be supported which is the assumption in the first 3GPP release, the procedure is to force the IWF to signal in-band with V.8 and V.8bis that the IWF does not support voice telephony mode.

Figure 6 provides a call establishment signalling flow for an mobile-originated direct H.324 multimedia telephony mode call to a terminating PSTN H.324 terminal.

As in MS-to-MS case, the mobile station equipped with 3G H.324 application initiates the call set-up procedure by sending an 04.08 SETUP message to the MSC/VLR. The BC IE conveyed in the SETUP message shall include parameter values as suggested in section 5.1.

- The MSC interprets the requested service from the BC information element and in case the called party would reside within digital call control domain (ISDN, other PLMN) terminating end would interpret it from the peer-to-peer transmitted 04.08/Q.931 LLC information element. By default in all MS originated calls, the 04.08 LLC IE is used to indicate H.223/H.245 peer-to-peer in case the called number should be within PLMN or ISDN domain. In MS-to-PSTN case the peer-to-peer information is not conveyed to the PSTN terminal, but originating terminal can not know the signalling domain of terminating terminal.

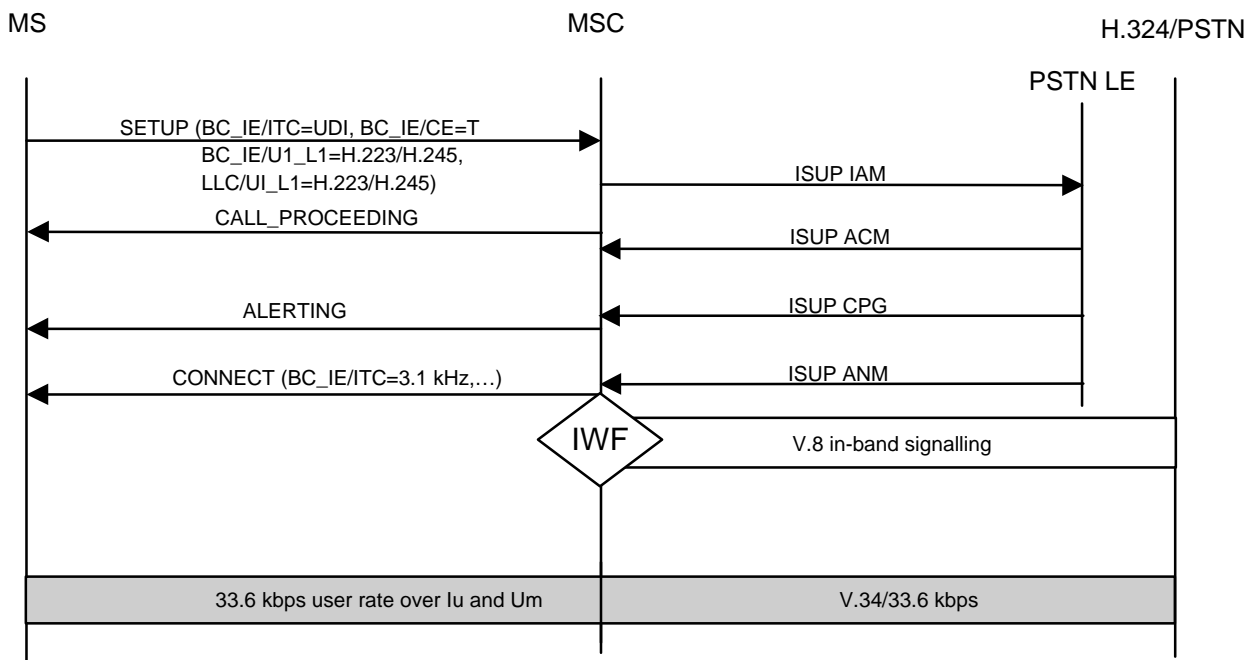

Figure 6. 3G-to-PSTN H.324 call set-up signalling

The MSC/VLR forwards an ISUP Initial Address Message (IAM) to the PSTN local exchange. The local exchange responds with ISUP messages Address Complete Message (ACM), Call Progress (CPG), and Answer Message (ANM) to the MSC/VLR which all result in corresponding 04.08 message (CALL PROCEEDING, ALERTING, CONNECT) towards the MS.

When PSTN local exchange responds by sending the ISUP messages it does not indicate any expected bearer service. Based on this information, connection is completed with MSC knowing that called party resides within PSTN signalling domain. Latest in the 04.08 CONNECT message the BC IE shall indicate that the information transfer mode (ITC) value for the bearer to be set up should be 3.1 kHz External to PLMN instead of originally suggested UDI mode. The list of relevant BC IE parameters with appropriate settings are listed in table 3.

Table 3. Corrected BC IE parameter values in MSC-MS direction, mobile originated H.324 call towards PSTN

Information Transfer Capability	3.1 kHz Ex PLMN
Duplex Mode	Full duplex
Sync/Async	Synchronous
Connection Element	Transparent
Fixed Network User Rate	33.6 kbit/s
Other Modem Type	V.34
User Information Layer 1	H.223/H.245

The call is switched via the IWF, and the IWF will execute a mapping from the 04.08 BC IE information received in SETUP to appropriate V.8/V.8bis signalling according to [2].

After reaching the connect phase the IWF modem shall start sending the V.8 CI messages indicating the H.324 in the call function octet (V.8 CF code 0x21). The PSTN H.324 terminal should then signal the H.324 capability in the V.8 JM (joint menu) call function octet. The call should be disconnected if no answer is received or the following V.8 CM/JM procedure indicates that H.324 is not available in the PSTN terminal.

When the appropriate V.8/V.8bis signalling is interpreted in PSTN end modem, it will start modem handshaking with involved modem in IWF, which results in a data connection between modems with a commonly agreed data modulation rate.

The CT 103 and CT 104 connectors in the IWF modem should be connected to the UTRAN bearer by the MSC after the radio bearer – modem data rate synchronisation procedure is ready. The connection is now complete for multimedia communication between the MS and PSTN terminal. Communication takes place in 3.1 kHz (external to the PLMN) bearer service involving V.34 modem at the MSC interworking function.

5.3 H.324 Call Set-up between 3G Terminal and a N-ISDN Multimedia Terminal (H.324 Annex D)

This section describes the required call set-up between H.324 terminals residing in 3G PLMN domain and in N-ISDN domain. The N-ISDN H.324 application is assumed to conform to H.324 Annex D, also known as H.324I. The assumptions are that within the digital PLMN-ISDN domain the 04.08 call control signalling should be interworking with corresponding Q.931 call control signalling, i.e., a.k.a. ISDN D-channel signalling. Also, it is assumed that H.324 Annex D terminals always use the whole unrestricted/restricted 64/56 kbit/s B-channel for the H.324 bitstream in the communication phase. That is, V.110 or bit stuffing are not used in the fixed network side.

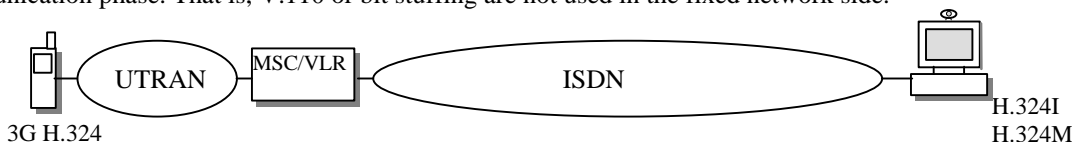

Figure 7. Connection architecture for 3G-to-ISDN/ISDN-to-3G H.324 calls.

5.3.1 Mobile originated call

As in section 5.1, the mobile station equipped with 3G H.324 application initiates the call set-up procedure by sending an 04.08 SETUP message to the MSC/VLR. The BC IE conveyed in the SETUP message shall include parameter values as suggested in table 4. Figure 8 includes the detailed signal flow for the call originated from 3G MS towards N-ISDN H.324 terminal.

Table 4. Relevant BC IE parameter values, MS-to-N-ISDN H.324 call

Information Transfer Capability	Unrestricted Digital Information
Duplex Mode	Full duplex
Sync/Async	Synchronous
Connection Element	Transparent
Wanted Air Interface User Rate	64 kbit/s
Fixed Network User Rate	64 kbit/s
User Information Layer 1	H.223/H.245*

*BC IE User Information Layer 1 is always sent in mobile originated SETUP message, but BC IE is guaranteed to reach only the MSC/VLR, not the N-ISDN terminal behind the N-ISDN local exchange.

The 04.08 LLC IE is used to indicate H.223/H.245 peer-to-peer, and thus is to be mapped to corresponding Q.931 LLC in the terminating ISDN local exchange. The called N-ISDN terminal should activate its H.324 application when receiving the Q.931 SETUP message with LLC IE User Information Layer 1 field signalling H.223/H.245 (value 00110).

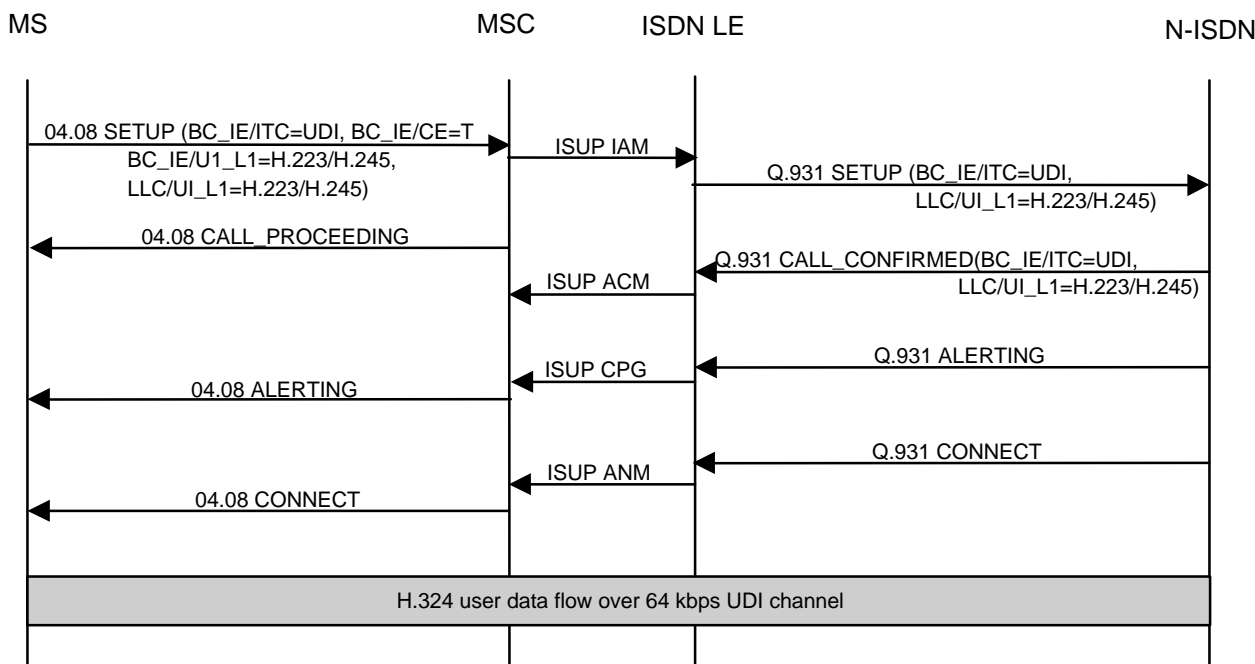

Figure 8. 3G-to-N-ISDN H.324 call set-up signalling

After the received 04.08 SETUP message the MSC/VLR sends an ISUP Initial Address Message (IAM) to the ISDN. The ISDN terminating local exchange responds with ISUP messages Address Complete Message (ACM), Call Progress (CPG), and Answer Message (ANM) to the MSC/VLR after receiving the appropriate Q.931 messages from the terminating N-ISDN H.324 terminal. MSC will map the ISUP messaging to 04.08 messages towards the mobile station. If the MS receives via the incoming ISUP and 04.08 messages the LLC value designated for H.223/H.245, the call is connected as a transparent UDI call with 64 kbit/s fixed network and UTRAN user bit rate. Call set-up is now complete to start multimedia communication between the MS and PSTN terminal, the in-band peer-to-peer multiplexing level exchange can be executed, and logical channels established using the H.245 open logical channel procedure.

5.3.2 Mobile terminated call

Figure 9 includes the detailed signal flow for the call originated from N-ISDN H.324 terminal towards mobile 3G H.324 terminal.

The N-ISDN terminal initiates the call set-up procedure by sending an Q.931 SETUP message towards the ISDN local exchange. The BC IE conveyed in the SETUP message should include at least the BC IE ITC and LLC parameter values to inform the network and peer about the requested bit rate (56/64 kbit/s, [2]), transfer mode and service type. After the received Q.931 SETUP message the LE sends an ISUP Initial Address Message (IAM) to the MSC/VLR.

- The H.324 Annex D states that digital call control signalling should be used when possible. In addition to the means described in this section, in-band signalling means such as V.140 [11] can be used after the connection has been established, to cover interworking scenarios from N-ISDN H.324 towards H.320 and PSTN-domain H.324 terminals. The PLMN interworking with these in-band signalling protocols is suggested FFS.

The Q.931 LLC IE is used to indicate H.223/H.245 peer-to-peer, and thus is to be mapped to corresponding 04.08 LLC in the terminating MSC/VLR. The called mobile terminal should activate its 3G H.324 application when receiving the 04.08 SETUP message with LLC IE User Information Layer 1 field signalling H.223/H.245 (value 0110).

The relevant fields and values for the BC IE originating from the MSC towards the terminating MS are as in table 4, assuming that the corresponding information can be translated from incoming ISUP IAM message.

The terminating MSC responds with ISUP messages Address Complete Message (ACM), Call Progress (CPG), and Answer Message (ANM) to the ISDN local exchange after receiving the appropriate 04.08 messages from the terminating mobile station. ISDN LE will map the ISUP messaging to Q.931 messages towards the N-ISDN terminal.

If the N-ISDN terminal receives via the incoming ISUP and Q.931 messages the LLC value designated for H.223/H.245, the call is connected as a transparent UDI call with 64 kbit/s fixed network and UTRAN user bit rate. Call set-up is now complete to start multimedia communication between the MS and PSTN terminal, the in-band peer-to-peer multiplexing level exchange can be executed, and logical channels established using the H.245 open logical channel procedure.

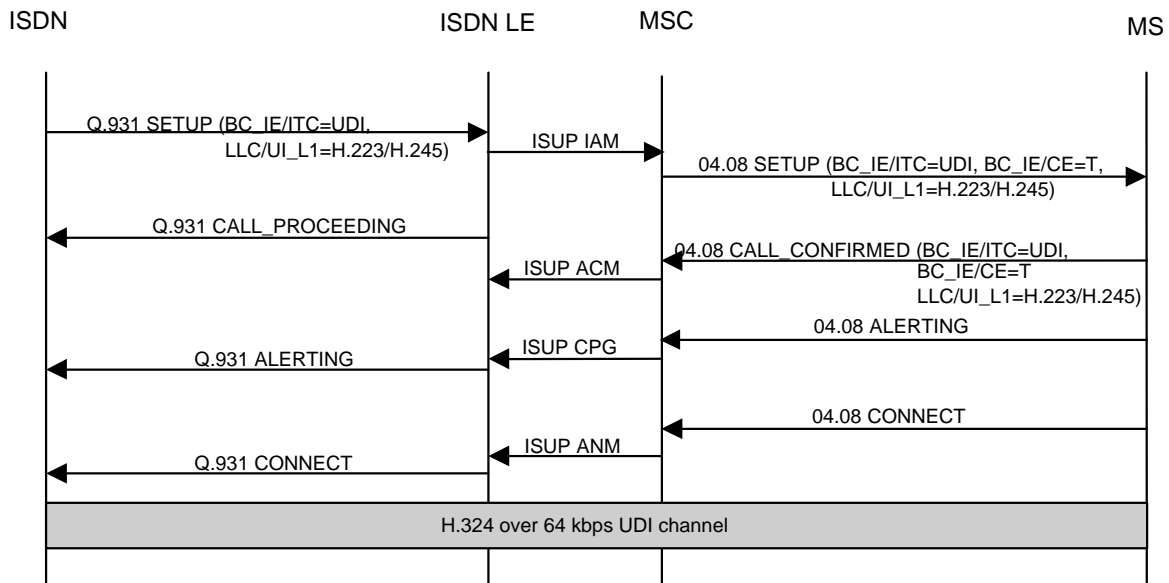

Figure 9. N-ISDN-to-3G H.324 call set-up signalling

6 Effect of Gateways for Call Set-up

Current assumption for call setup requirements is that the used codecs are negotiated on peer-to-peer basis with the aid of H.245 capability exchange protocol, being outside the scope of this specification. Possible introduction of H.324 gateways that implement media transcoding (such as AMR to G.723.1 speech and vice versa) at the MSC interface to provide interworking between 3G and external circuit switched multimedia services is FFS. Transcoding gateways may introduce changes to call set-up requirements, such as numbering, capability exchange etc.. This is FFS in 3GPP.

History

Document history		
V.0.0.1	1999-04-20	Publication of draft baseline specification in TSG-S4#4
V.1.0.0	1999-04-22	TSG-S4 approved version for information to TSG-SA#3