

Presentation of Specification to TSG RAN

Presentation to: TSG RAN Meeting # 27

Document for presentation: TR25.808, Version 2.0.0

Presented for: Approval

Abstract of document:

The TR25.808, FDD Enhanced Uplink; Physical Layer Aspects is a TSG RAN WG1 technical report capturing the WG1's agreements of the different techniques for FDD Enhanced Uplink. In particular, this version of the TR contains the agreements included in the RAN1 approved FDD Enhanced Uplink CRs presented for this RAN meeting for approval [2,..., 10].

Changes since last presentation to TSG RAN:

Overview of changes is presented in [1], and detailed list of changes are reflected in CRs [2,..., 10].

Outstanding Issues:

Clarification of outstanding issues are presented in [1]

Contentious Issues:

Clarification of contentious issues are presented in [1]

References:

- [1] RP-050016, Status Report for WI FDD Enhanced Uplink
- [2] RP-050043, CRs (Rel-6 Category F) to TS25.211 for E-HICH/E-RGCH Signature Sequences and Signature Sequence Hopping
- [3] RP-050090, CR (Rel-6 Category F) to TS25.211 for E-HICH/E-RGCH/E-AGCH timing
- [4] RP-050044, CR (Rel-6 Category F) to TS25.212 for PLnon-max and Plmax
- [5] RP-050045, CR (Rel-6 Category C) to TS25.212 for HARQ bit collection for E-DCH
- [6] RP-050046, CR (Rel-6 Category F) to TS25.213 for Correction on E-DPCCH power offset
- [7] RP-050047, CR (Rel-6 Category F) to TS25.213 for Defining E-DPDCH power offset
- [8] RP-050048, CR (Rel-6 Category F) to TS25.214 for Gain factor setting for E-DCH
- [9] RP-050049, CR (Rel-6 Category F) to TS25.214 for Reliable E-RGCH/E-HICH Detection
- [10] RP-050091, CR (Rel-6 Category F) to TS25.214 for DL/UL timing association of E-DCH operation

3GPP TR 25.808 V2.0.0 (2005-03)

Technical Report

**3rd Generation Partnership Project;
Technical Specification Group Radio Access Network;
FDD Enhanced Uplink;
Physical Layer Aspects
(Release 6)**



The present document has been developed within the 3rd Generation Partnership Project (3GPPTM) and may be further elaborated for the purposes of 3GPP.

The present document has not been subject to any approval process by the 3GPP Organizational Partners and shall not be implemented. This Specification is provided for future development work within 3GPP only. The Organizational Partners accept no liability for any use of this Specification. Specifications and reports for implementation of the 3GPPTM system should be obtained via the 3GPP Organizational Partners' Publications Offices.

Keywords

UMTS, radio, packet mode, layer 1

3GPP

Postal address

3GPP support office address

650 Route des Lucioles - Sophia Antipolis
Valbonne - FRANCE
Tel.: +33 4 92 94 42 00 Fax: +33 4 93 65 47 16

Internet

<http://www.3gpp.org>

Copyright Notification

No part may be reproduced except as authorized by written permission.
The copyright and the foregoing restriction extend to reproduction in all media.

© 2004, 3GPP Organizational Partners (ARIB, ATIS, CCSA, ETSI, TTA, TTC).
All rights reserved.

Contents

Foreword.....	5
1 Scope	6
2 References	6
3 Definitions, symbols and abbreviations.....	6
3.1 Definitions.....	6
3.2 Symbols.....	6
3.3 Abbreviations	7
4 Introduction	8
5 Basic Physical Layer Structure.....	8
5.1 CTrCH and Transport Channel Structure	8
5.2 Overall Physical Channel Structure	8
6 Hybrid ARQ Scheme.....	8
6.1 HARQ Scheme of the FDD Enhanced Uplink	8
6.2 Signalling Information Required for the Support of HARQ	8
6.2.1 Retransmission Sequence Number (RSN).....	8
6.3 Operation in SHO.....	9
7 Support of the Node B Controlled Uplink Scheduling.....	9
7.1 Scheduling Scheme of the FDD Enhanced Uplink	9
7.2 Signalling Information Required for the Support of the Scheduling.....	9
7.3 Operation in SHO.....	10
8 Physical Channel Structure.....	10
8.1 Physical Channel Structure for Data Transmission.....	10
8.1.1 E-DPDCH.....	10
8.1.2 Timing	10
8.2 Physical Channel Structure for Downlink Control Signalling	11
8.2.1 E-DCH HARQ Acknowledgement Indicator Channel (E-HICH).....	11
8.2.2 E-DCH Relative Grant Channel (E-RGCH).....	11
8.2.3 E-DCH Absolute Grant Channel (E-AGCH).....	11
8.2.4 Downlink transmit diversity for E-AGCH, E-RGCH and E-HICH.....	12
8.2.5 Phase reference for E-AGCH, E-RGCH and E-HICH	12
8.2.6 DL E-HICH/P-CCPCH/DPCH timing relation	12
8.2.7 DL E-RGCH/P-CCPCH/DPCH timing relation	12
8.2.8 E-AGCH/P-CCPCH timing relation.....	12
8.3 Physical Channel Structure for Uplink Control Signalling	12
8.3.1 E-DPCCH.....	12
8.3.1.1 Timing	13
9 Multiplexing, Channel Coding and Interleaving	13
9.1 E-DCH Multiplexing, Coding and Interleaving	13
9.1.1 CRC attachment.....	14
9.1.2 Code block segmentation.....	14
9.1.3 Channel coding.....	15
9.1.4 Physical layer HARQ functionality and rate matching.....	15
9.1.4.1 HARQ bit separation	15
9.1.4.2 HARQ Rate Matching Stage	15
9.1.4.3 HARQ bit collection.....	16
9.1.5 Physical channel segmentation for E-DCH	16
9.1.6 Interleaving for E-DCH.....	16
9.1.7 Physical channel mapping for E-DCH	16
9.1.8 Determination of SF and number of E-DPDCHs needed	16
9.2 Downlink Signalling Coding and Multiplexing	18
9.2.1 Mapping for E-HICH ACK/NACK.....	18

9.2.1.1	Overview	18
9.2.1.2	ACK/NACK mapping	18
9.2.2	Mapping for E-RGCH Relative Grant	18
9.2.2.1	Overview	18
9.2.2.2	Relative Grant mapping	18
9.2.3	E-AGCH	18
9.2.3.1	Overview	18
9.2.3.2	E-AGCH information field mapping	19
9.2.3.3	CRC attachment for E-AGCH	19
9.2.3.4	Channel coding for E-AGCH	19
9.2.3.5	Rate matching for E-AGCH	19
9.2.3.6	Physical channel mapping for E-AGCH	20
9.3	E-DPCCH Coding and Multiplexing	20
9.3.1	Overview	20
9.3.2	E-DPCCH information field mapping	20
9.3.2.1	Information field mapping of E-TFCl	20
9.3.2.2	Information field mapping of retransmission sequence number	20
9.3.3	Multiplexing of E-DPCCH information	21
9.3.4	Channel coding for E-DPCCH	21
9.3.5	Physical channel mapping for E-DPCCH	21
10	Spreading and Modulation	22
10.1	E-DPCCH/E-DPDCH	22
10.1.1	Spreading	22
10.1.2	Code allocation	23
10.1.2.1	Channelization code for E-DPCCH, E-DPDCH and HS-DPCCH	23
10.1.2.2	Channelisation code for HS-DPCCH	23
10.1.2.3	Scrambling	24
10.2	E-HICH, E-RGCH and E-AGCH	24
11	Physical Layer Procedures	24
11.1	Power control of E-AGCH/E-HICH/E-RGCH	24
11.2	E-DCH related procedures	24
11.2.1	ACK/NACK detection	24
11.2.2	Relative grants detection	24
11.2.3	E-DCH control timing	25
11.3	Setting of the uplink DPCCH/E-DPCCH and E-DPDCH power difference	25
12	Physical Layer Measurements	25
13	UE Physical Layer Capabilities	25
Annex A: Change history		26

Foreword

This Technical Report has been produced by the 3rd Generation Partnership Project (3GPP).

The contents of the present document are subject to continuing work within the TSG and may change following formal TSG approval. Should the TSG modify the contents of the present document, it will be re-released by the TSG with an identifying change of release date and an increase in version number as follows:

Version x.y.z

where:

- x the first digit:
 - 1 presented to TSG for information;
 - 2 presented to TSG for approval;
 - 3 or greater indicates TSG approved document under change control.
- y the second digit is incremented for all changes of substance, i.e. technical enhancements, corrections, updates, etc.
- z the third digit is incremented when editorial only changes have been incorporated in the document.

1 Scope

The present document captures the agreements of the different techniques for FDD Enhanced Uplink, namely the support of Node B controlled scheduling, hybrid ARQ and shorter TTI, with regards to the overall support of UTRA FDD Enhanced Uplink.

The technical objective of this work item is the Enhanced Uplink functionality in UTRA FDD, to improve the performance of uplink dedicated transport channels.

2 References

The following documents contain provisions which, through reference in this text, constitute provisions of the present document.

- References are either specific (identified by date of publication, edition number, version number, etc.) or non-specific.
- For a specific reference, subsequent revisions do not apply.
- For a non-specific reference, the latest version applies. In the case of a reference to a 3GPP document (including a GSM document), a non-specific reference implicitly refers to the latest version of that document *in the same Release as the present document*.

[<seq>] <doctype> <#>[([up to and including]{yyyy[-mm]}V<a[.b[.c]]>}{onwards})]: "<Title>".

[1] 3GPP TR 25.896 (V6.0.0): "Feasibility Study for Enhanced Uplink for UTRA FDD".

[2] 3GPP TS 25.309: "UTRA FDD Enhanced Uplink stage 2".

3 Definitions, symbols and abbreviations

3.1 Definitions

For the purposes of the present document, the following terms and definitions apply.

Serving E-DCH cell: Cell from which the UE receives Absolute Grants from the Node-B scheduler. A UE has one Serving E-DCH cell.

Serving E-DCH RLS or Serving RLS: Set of cells which contains at least the Serving E-DCH cell and from which the UE can receive and combine one Relative Grant. The UE has only one Serving E-DCH RLS.

Non-serving E-DCH RLS or Non-serving RLS: Set of cells which does not contain the Serving E-DCH cell and from which the UE can receive and combine one Relative Grant. The UE can have zero, one or several Non-serving E-DCH RLS.

3.2 Symbols

For the purposes of the present document, the following symbols apply:

<symbol> <Explanation>

3.3 Abbreviations

For the purposes of the present document, the following abbreviations apply:

E-AGCH	E-DCH Absolute Grant Channel
E-HICH	E-DCH HARQ Acknowledgement Indicator Channel
E-RGCH	E-DCH Relative Grant Channel
E-DPCCH	E-DCH Dedicated Physical Control Channel
E-DPDCH	E-DCH Dedicated Physical Data Channel

4 Introduction

In TSG RAN plenary meeting #23, a work item for the FDD Enhanced Uplink was initiated. The WI is justified by the findings of the study item Uplink Enhancements for Dedicated Transport Channels. The aim of the study was to look at the feasibility of enhancing the uplink DCH operation and performance by several techniques in order to support services like video-clips, multimedia, e-mail, telematics, gaming, video-streaming.... The RAN study showed that various techniques such as Node-B controlled scheduling, shorter TTI and a hybrid ARQ layer in the Node-B, can enhance the uplink packet transfer performance significantly compared to Release-99/Rel-4/Rel-5. The study item findings are captured in [1].

The technical objective of this work item is the Enhanced Uplink functionality in UTRA FDD, to improve the performance of uplink dedicated transport channels. The improvements should take into account backwards compatibility aspects.

For physical layer, the FDD Enhanced Uplink specification work includes:

- Physical and Transport Channels mapping
- Multiplexing and Channel Coding
- Physical Layer procedures
- Physical layer measurements
- UE physical layer capabilities

5 Basic Physical Layer Structure

5.1 CCTrCH and Transport Channel Structure

There is at most one CCTrCH of E-DCH type per UE and only one E-DCH per CCTrCH of E-DCH type. The E-DCH supports one transport block per E-DCH TTI. Both 2 ms TTI and 10 ms TTI are supported by the E-DCH.

5.2 Overall Physical Channel Structure

The CCTrCH of E-DCH type and the CCTrCH of DCH type are mapped to different physical channels.

6 Hybrid ARQ Scheme

6.1 HARQ Scheme of the FDD Enhanced Uplink

6.2 Signalling Information Required for the Support of HARQ

6.2.1 Retransmission Sequence Number (RSN)

To indicate the redundancy version (RV) of each HARQ transmission and to assist the Node B soft buffer management a two bit retransmission sequence number (RSN) is signalled from the UE to the Node B. The applied E-DCH RV index as described in 9.3 depends on the RSN for $RSN < 3$ and on TTI number for $RSN = 3$. (For 10 ms TTI the TTI number is equal to CFN. For 2 ms TTI the TTI number is equal to $5 \times CFN + \text{sub-frame number}$).

The RSN value for each initial transmission of an E-DCH transport block is 0. For the first retransmission the RSN value is 1, for the second retransmission the RSN value is 2 and for each further retransmission the RSN value is 3. Table 6.2.1 shows the RSN values depending on the transmission number.

Table 6.2.1: RSN value for the initial transmission and for retransmissions

Transmission Number	RSN value
0 (initial transmission)	0
1	1
2	2
>2	3

6.3 Operation in SHO

7 Support of the Node B Controlled Uplink Scheduling

7.1 Scheduling Scheme of the FDD Enhanced Uplink

Note: The following working assumption has been agreed by RAN1, under the condition that a satisfactory solution for resource handling with respect to Node B hardware under/over-allocation in soft handover is identified.

The UE can receive two types of grants

- relative grants, consisting of one bit per time interval
- absolute grants, consisting of multiple bits per time interval

Neither type of grant has to be transmitted in every time interval, i.e., DTX may be used, depending on the scheduling strategy implemented. The time interval equals the E-DCH TTI configured.

The UE is informed by higher layer signaling or in another way on which physical resource (e.g., OVSF code) it can find the respective grant. The network may configure each UE to monitor an individual physical resource, or multiple UEs to monitor the same physical resource. Seen from the UE, there is no difference between these two cases.

In non-soft handover, there is only a single cell responsible for E-DCH scheduling, the serving E-DCH cell. In soft handover, there is one serving E-DCH cell and at least one non-serving E-DCH cell. The UE shall be capable of receiving

- one absolute grant and one relative grant per time interval from the serving E-DCH cell
- one relative grant per time interval from each of the non-serving E-DCH cells

The relative grant from the serving E-DCH radio link set shall be interpreted as an UP/HOLD/DOWN command for relative rate scheduling. The interpretation of the relative grants from the non-serving E-DCH radio link sets and the absolute grant from the serving E-DCH cell is FFS.

7.2 Signalling Information Required for the Support of the Scheduling

It is FFS whether a grant controls the maximum (E-DPDCH+DPDCH)/DPCCH power ratio or the maximum E-DCH transport format the UE may use in a TTI.

7.3 Operation in SHO

8 Physical Channel Structure

8.1 Physical Channel Structure for Data Transmission

8.1.1 E-DPDCH

The E-DPDCH is a new physical channel on which the CCTrCh of E-DCH type shall be mapped. The E-DPDCH definition and attributes are the same as the DPDCH except where noted.

Figure 8.1.1 shows the E-DPDCH frame structure. The E-DPDCH radio frame is divided in 5 subframes, each of length 2 ms; the first subframe starts at the start of each E-DPDCH radio frame and the 5th subframe ends at the end of each E-DPDCH radio frame.

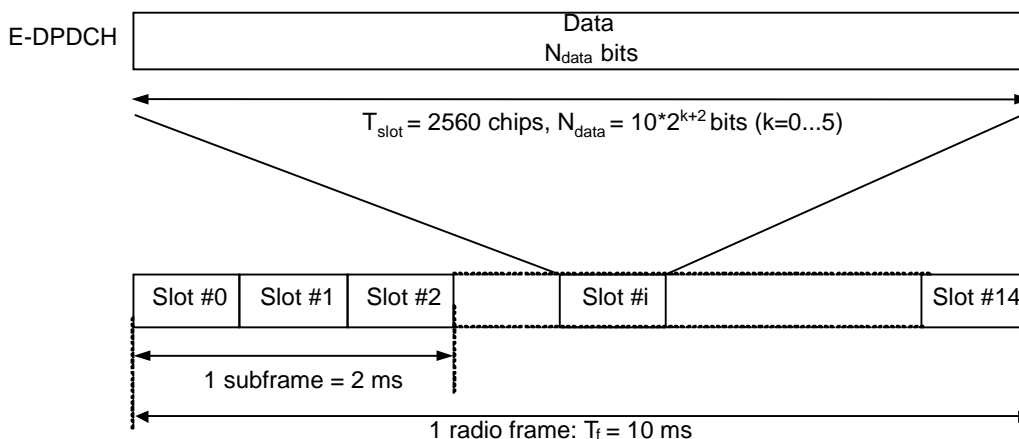

Figure 8.1.1: E-DPDCH frame structure

E-DPDCH slot formats, corresponding rates and number of bits are specified in table 8.1.1.

Table 8.1.1: E-DPDCH fields

Slot Format #1	Channel Bit Rate (kbps)	SF	Bits/ Frame	Bits/ Subframe	Bits/Slot N _{data}
0	60	64	600	120	40
1	120	32	1200	240	80
2	240	16	2400	480	160
3	480	8	4800	960	320
4	960	4	9600	1920	640
5	1920	2	19200	3840	1280

8.1.2 Timing

The radio frames of all the E-DPDCHs transmitted by a UE shall be time aligned with the UE's UL DPCCH radio frames.

8.2 Physical Channel Structure for Downlink Control Signalling

8.2.1 E-DCH HARQ Acknowledgement Indicator Channel (E-HICH)

The E-DCH HARQ Acknowledgement indicator channel (E-HICH) is a fixed rate (SF=128) downlink physical channel carrying the uplink E-DCH Hybrid-ARQ Acknowledgement (HARQ-ACK) indicator. Figure 8.2.1 illustrates the structure of the E-HICH. A hybrid ARQ acknowledgement indicator is transmitted using 3 or 12 consecutive slots and in each slot a sequence of 40 binary values is transmitted. The 3 and 12 slot duration shall be used for UEs which E-DCH TTI is set to respectively 2 ms and 10 ms.

The sequence $b_{i,0}, b_{i,1}, \dots, b_{i,39}$ transmitted in slot i in Figure 8.2.1 is given by $b_{i,j} = a C_{ss,40,m(i),j}$. In a radio link set containing the serving E-DCH radio link set, the hybrid ARQ acknowledgement indicator a is set to +1 or -1, and in a radio link set not containing the serving E-DCH radio link set the hybrid ARQ indicator a is set to +1 or 0. The orthogonal signature sequences $C_{ss,40,m(i)}$ is given by Table 16A of TS25.211 and the index $m(i)$ in slot i is given by table 16B of TS25.211. The E-HICH signature sequence index l is given by higher layers.

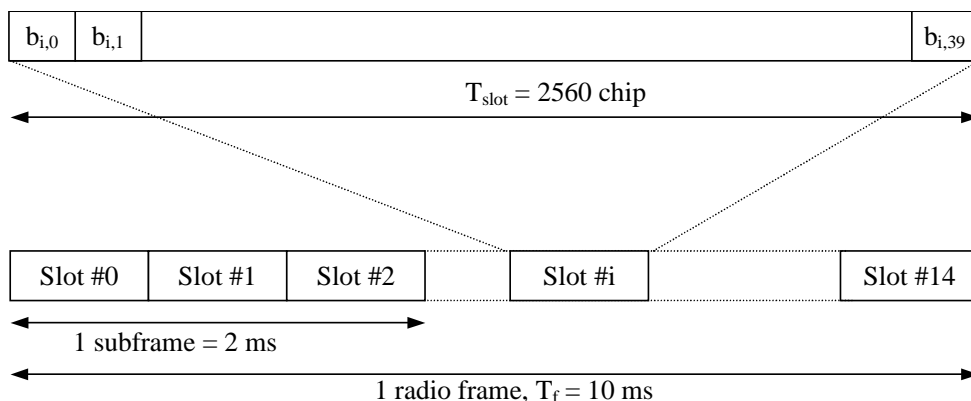

Figure 8.2.1: E-HICH/E-RGCH structure

8.2.2 E-DCH Relative Grant Channel (E-RGCH)

The E-DCH relative grant channel (E-RGCH) is a fixed rate (SF=128) downlink physical channel carrying the uplink E-DCH Relative Grants. Figure 8.2.1 illustrates the structure of the E-RGCH. A relative grant is transmitted using 3, 12 or 15 consecutive slots and in each slot a sequence of 40 ternary values is transmitted. The 3 and 12 slot duration shall be used to control UEs for which the cell is the E-DCH serving cell and which E-DCH TTI is respectively 2 and 10 ms. The 15 slot duration shall be used to control UEs for which the cell is not the E-DCH serving cell. For E-RGCH transmitted to a UE from a non-serving E-DCH Radio Link Set only two of the three ternary values are used.

The sequence $b_{i,0}, b_{i,1}, \dots, b_{i,39}$ transmitted in slot i in Figure 8.2.1 is given by $b_{i,j} = a C_{ss,40,m(i),j}$. In a serving E-DCH radio link set, the relative grant a is set to +1, 0, or -1 and in a non-serving E-DCH radio link set, the relative grant a is set to 0 or -1. The orthogonal signature sequences $C_{ss,40,m(i)}$ is given by Table 16A of TS25.211 and the index $m(i)$ in a slot i is given by Table 16B of TS25.211. The E-RGCH signature sequence index l is given by higher layers.

8.2.3 E-DCH Absolute Grant Channel (E-AGCH)

The E-DCH absolute grant channel (E-AGCH) is a fixed rate (30 kbps, SF=256) downlink common physical channel carrying the uplink E-DCH Absolute Grant. Figure 8.2.3 illustrates the frame and sub-frame structure of the E-AGCH.

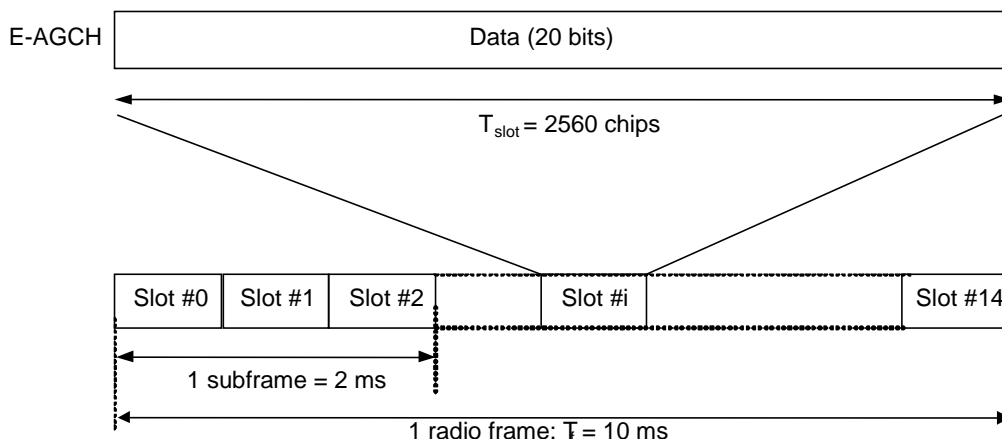

Figure 8.2.3: Sub-frame structure for the E-AGCH

The UE shall monitor at least one E-AGCH from the serving E-DCH Cell when an uplink E-DCH is configured by higher layers.

8.2.4 Downlink transmit diversity for E-AGCH, E-RGCH and E-HICH

If the UE is receiving a DPCH on which transmit diversity is used from a cell, the UE shall assume that the E-AGCH, E-RGCH, and E-HICH from the same cell are transmitted using STTD.

E-RGCH/E-HICH: In case STTD-based open loop transmit diversity is applied, STTD encoding according to subclause 5.3.1.1.1 of TS25.211 is applied to the sequence $b_{i,j}$

8.2.5 Phase reference for E-AGCH, E-RGCH and E-HICH

The same phase reference as with the associated DPCH shall be used for E-AGCH, E-RGCH and E-HICH. The support for dedicated pilots as phase reference for E-AGCH, E-RGCH and E-HICH (as is the case with HS-PDSCH and HS-SCCH) is optional for the UE.

8.2.6 DL E-HICH/P-CCPCH/DPCH timing relation

DL E-HICH/P-CCPCH/DPCH timing relation is specified in chapter 7.10 of TS25.211.

8.2.7 DL E-RGCH/P-CCPCH/DPCH timing relation

DL E-RGCH/P-CCPCH/DPCH timing relation is specified in chapter 7.11 of TS25.211.

8.2.8 E-AGCH/P-CCPCH timing relation

E-AGCH/P-CCPCH timing relation is specified in chapter 7.12 of TS25.211.

8.3 Physical Channel Structure for Uplink Control Signalling

8.3.1 E-DPCCH

The E-DPCCH is a new code multiplexed uplink physical channel used to transmit control signalling associated with the E-DCH

The E-DPCCH has the same framing structure as the E-DPDCH (see section 8.1.1); The E-DPCCH slot format is listed in table 8.3.1

Table 8.3.1: E-DPCCH fields

Slot Format #	Channel Bit Rate (kbps)	SF	Bits/Frame	Bits/Subframe	Bits/Slot N_{data}
0	15	256	150	30	10

8.3.1.1 Timing

The E-DPCCH radio frame and sub-frame boundaries are time aligned with the E-DPDCH radio frame and sub-frame boundaries.

9 Multiplexing, Channel Coding and Interleaving

9.1 E-DCH Multiplexing, Coding and Interleaving

Figure 9.1.1 shows the processing structure for E-DCH transport channel mapped onto a separate CCH. Data arrives to the transport channel processing unit in form of one transport block once per transmission time interval (TTI). The following processing steps can be identified:

- Add CRC to the transport block. CRC facilitates detection of error in E-DCH decoding at Node B.
- Code block segmentation. The value of maximum code block size $Z = 5114$ for turbo coding shall be used.
- Channel coding. The rate 1/3 turbo coding shall be used.
- Physical layer hybrid ARQ and rate matching. This block generates transmitted bit pattern extracted from the output of the channel coding and matches the number of input bits to the number of available physical channel bits within the TTI.
- Physical channel segmentation
- Interleaving and physical channel mapping. Input bits are interleaved and mapped to physical channel(s) allocated for E-DCH TTI transmission.

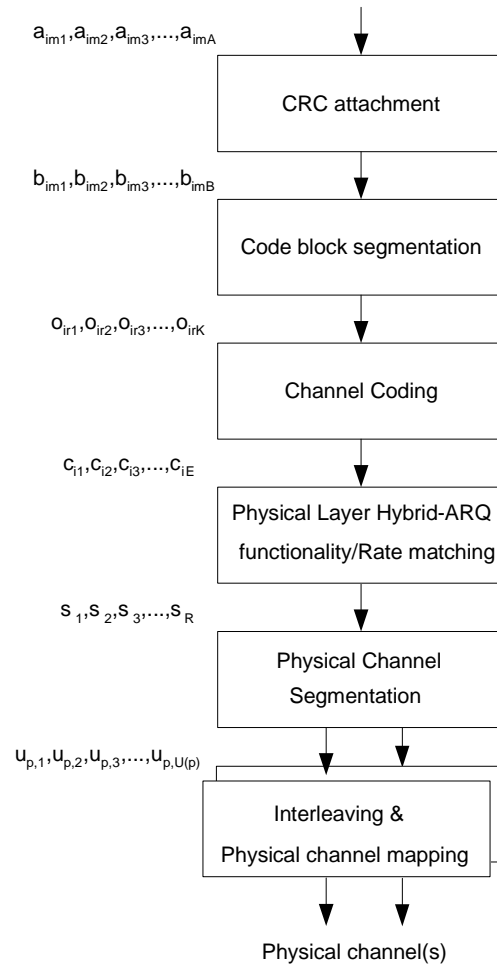

Figure 9.1.1: TrCH processing for E-DCH

9.1.1 CRC attachment

CRC attachment for the E-DCH transport channel shall be performed according to the general method described in section 4.2.1 of TS 25.212 with the following specific parameters:

- The CRC length shall always be $L_i = 24$ bits.

9.1.2 Code block segmentation

Code block segmentation for the E-DCH transport channel shall be performed according to the general method described in 4.2.2 of TS 25.212 with the following specific parameters:

- Maximum number of transport block is 1.
- The bits $b_{im1}, b_{im2}, b_{im3}, \dots, b_{imBi}$ input to the block are mapped to the bits $x_{i1}, x_{i2}, x_{i3}, \dots, x_{iXi}$ directly. It follows that $X_i = B_i$. Note that the bits x referenced here refer only to the internals of the code block segmentation function. The output bits from the code block segmentation function are $o_{ir1}, o_{ir2}, o_{ir3}, \dots, o_{irK}$.
- The value of $Z = 5114$ for turbo coding shall be used

9.1.3 Channel coding

Channel coding for the E-DCH transport channel shall be performed according to the general method described in section 4.2.3 of TS 25.212 with the following specific parameters:

- There is a maximum of one transport block, $i=1$
- The rate 1/3 turbo coding shall be used.

9.1.4 Physical layer HARQ functionality and rate matching

HARQ functionality and rate matching for the E-DCH transport channel shall be performed according to the general method described in section 4.5.4 of TS 25.212 with the following exceptions:

- The first rate matching stage shall be transparent.
- $N_{\text{row}}=2$ shall be assumed in section section 4.5.4.4 of TS25.212

The hybrid ARQ functionality matches the number of bits at the output of the channel coder to the total number of bits of the E-DPDCH set to which the E-DCH transport channel is mapped. The hybrid ARQ functionality is controlled by the redundancy version (RV) parameters.

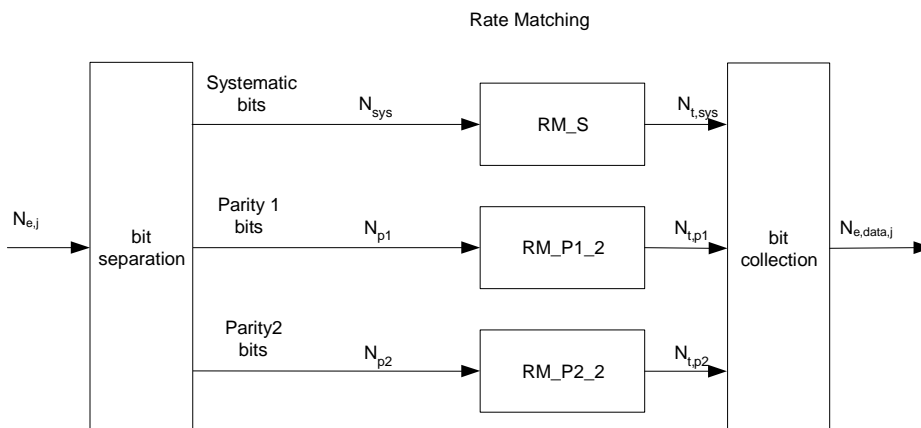

Figure 9.1.2: E-DCH hybrid ARQ functionality

9.1.4.1 HARQ bit separation

The HARQ bit separation function shall be performed in the same way as bit separation for turbo encoded TrCHs in section 4.2.7.4.1 of TS25.212.

9.1.4.2 HARQ Rate Matching Stage

The hybrid ARQ rate matching for the E-DCH transport channel shall be done with the general method described in section 4.2.7.5 of TS25.212 with the following specific parameters. Bits selected for puncturing which appear as δ in the algorithm in section 4.2.7.5 of TS25.212 shall be discarded and are not counted in the streams towards the bit collection.

The parameters of the rate matching stage depend on the value of the RV parameters s and r . The s and r combinations corresponding to each RV allowed for the E-DCH are listed in the table below.

Table 9.1.1: RV for E-DCH

E-DCH RV Index	S	r
0	1	0
1	0	0
2	1	1
3	0	1

The parameter e_{plus} , e_{minus} and e_{ini} are calculated with the general method for QPSK as described in section 4.5.4.3 of TS25.212. The following parameters are used as input:

$$- N_{sys} = N_{p1} = N_{p2} = N_{e,j}/3$$

$$- N_{data} = N_{e,data,j}$$

$$- r_{max} = 2$$

9.1.4.3 HARQ bit collection

The HARQ bit collection shall be performed according to the general method for bit collection as specified in section 4.2.7.4.2 of TS25.212.

9.1.5 Physical channel segmentation for E-DCH

When more than one E-DPDCH is used, physical channel segmentation distributes the bits among the different physical channels. The bits input to the physical channel segmentation are denoted by $s_1, s_2, s_3, \dots, s_R$, where R is the number of bits input to the physical channel segmentation block. The number of PhCHs is denoted by P .

The bits after physical channel segmentation are denoted $u_{p,k}$ where p is the PhCH number. $U(p)$ is the number of physical channel bits in one E-DCH TTI for the p^{th} E-DPDCH. The relation between s_k and $u_{p,k}$ is given below.

Bits on first PhCH after physical channel segmentation:

$$u_{1,k} = s_k \quad k = 1, 2, \dots, U(1)$$

Bits on p^{th} PhCH after physical channel segmentation:

$$u_{p,k} = s_{k + \sum_{q=1}^{p-1} U(q)} \quad k = 1, 2, \dots, U(p)$$

9.1.6 Interleaving for E-DCH

Interleaving for the E-DCH transport channel shall be done according to the general method described in section 4.2.11 with the specific parameter $U=U(p)$.

9.1.7 Physical channel mapping for E-DCH

The E-DCH structure is described in TS25.211. The bits input to the physical channel mapping are denoted $v_{p,1}, v_{p,2}, \dots, v_{p,U(p)}$. The bits $v_{p,k}$ are mapped to the PhCHs such that the bits for each PhCH are transmitted over the air in ascending order with respect to k .

9.1.8 Determination of SF and number of E-DPDCHs needed

In E-DCH transmission, puncturing can be applied to match the E-DCH bit rate to the E-DPDCH bit rate. The bit rate of the E-DPDCH(s) is limited by the UE capability and restrictions imposed by UTRAN, through limitations on the E-DPDCH spreading factor.

The maximum amount of puncturing that can be applied is

- $1-PL_{\text{non-max}}$ if the number of code channels is less than the maximum allowed by the UE capability and restrictions imposed by UTRAN.
- $1-PL_{\text{max}}$ if the number of code channels equals to the maximum allowed by the UE capability and restrictions imposed by UTRAN.

$PL_{\text{non-max}}$ and PL_{max} can be either defined by specifications or signalled from higher layers [FFS]. The number of available bits in the radio frames or subframes of one E-DPDCH for all possible spreading factors is denoted by N_{64} , N_{32} , N_{16} , N_8 , N_4 and N_2 , where the index refers to the spreading factor.

The possible number of bits available to the CCTrCH of E-DCH type on all E-DPDCHs, $N_{e,data}$, then are $\{N_{64}, N_{32}, N_{16}, N_8, N_4, 2 \times N_4, 2 \times N_2, 2 \times N_2 + 2 \times N_4\}$.

SET0 denotes the set of $N_{e,data}$ values allowed by the UTRAN and supported by the UE, as part of the UE's capability. SET0 can be a subset of $\{N_{64}, N_{32}, N_{16}, N_8, N_4, 2 \times N_4, 2 \times N_2, 2 \times N_2 + 2 \times N_4\}$.

The total number of bits in a TTI before rate matching with transport format j is $N_{e,j}$. The total number of bits available for the E-DCH transmission per TTI with transport format j , $N_{e,data,j}$, is determined by executing the following algorithm, where $PL_{\text{non-max}}$ is signalled from higher layers and PL_{max} is equal to 0.44 for all E-DCH UE categories defined in TS25.306 except the highest E-DCH UE category, for which PL_{max} is equal to 0.33:

SET1 = { $N_{e,data}$ in SET0 such that $N_{e,data} - N_j$ is non negative }

If SET1 is not empty and the smallest element of SET1 requires just one E-DPDCH then /* no puncturing with one E-DPDCH */

$N_{e,data,j} = \min \text{ SET1}$ /* max SF is chosen with one E-DPDCH without puncturing */

else /* puncturing is needed */

SET2 = { $N_{e,data}$ in SET0 such that $N_{e,data} - PL_{\text{non-max}} \times N_j$ is non negative }

If SET2 is not empty then

Sort SET2 in ascending order

$N_{e,data} = \min \text{ SET2}$ /* minimize the number of codes with allowing puncturing within the puncturing limit $(1-PL_{\text{non-max}})$ */

While $N_{e,data}$ is not the max of SET2 and the follower of $N_{e,data}$ requires no additional E-DPDCH do

$N_{e,data} = \text{follower of } N_{e,data} \text{ in SET2}$ /* minimize the amount of puncturing without increasing the number of codes */

End while

$N_{e,data,j} = N_{e,data}$

else

$N_{e,data,j} = \max \text{ SET0}$ provided that $N_{e,data,j} - PL_{\text{max}} \times N_j$ is non negative

End if

End if

9.2 Downlink Signalling Coding and Multiplexing

9.2.1 Mapping for E-HICH ACK/NACK

9.2.1.1 Overview

The ACK/NACK is transmitted on the E-HICH as described in chapter 8.

9.2.1.2 ACK/NACK mapping

The ACK/NACK command is mapped to the HARQ acknowledgement indicator as described in the table below.

Table 9.2.1: Mapping of HARQ Acknowledgement

Command	HARQ acknowledgement indicator
ACK	+1
NACK (RLSs not containing the serving E-DCH cell)	0
NACK (RLS containing the serving E-DCH cell)	-1

9.2.2 Mapping for E-RGCH Relative Grant

9.2.2.1 Overview

The relative grant is transmitted on the E-RGCH as described in chapter 8.

9.2.2.2 Relative Grant mapping

The relative grant (RG) command is mapped to the relative grant value as described in the table below.

Table 9.2.2: Mapping of RG value

Command	RG Value (serving E-DCH RLS)	RG Value (non serving E-DCH RLS)
UP	+1	not allowed
HOLD	0	0
DOWN	-1	-1

9.2.3 E-AGCH

The absolute grant $x_{ag,1}, x_{ag,2}, \dots, x_{ag,w}$ is transmitted by means of the absolute grant channel (E-AGCH).

9.2.3.1 Overview

Figure 9.2.1 illustrates the overall coding chain for the E-AGCH.

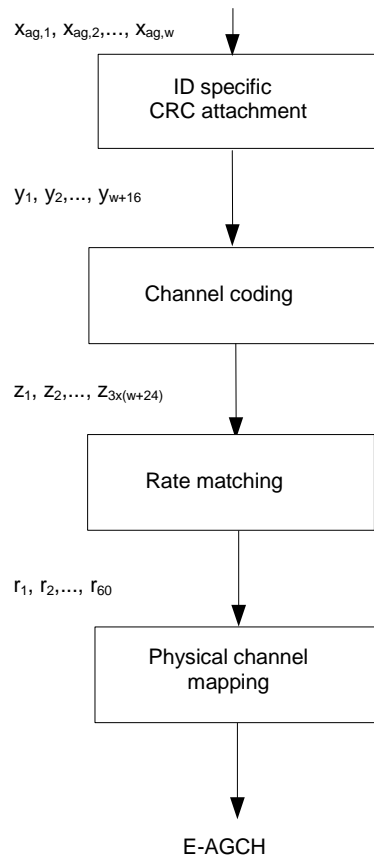

Figure 9.2.1: Coding for E-AGCH

9.2.3.2 E-AGCH information field mapping

The absolute grant (AG) information is denoted x_1, x_2, \dots, x_X .

9.2.3.3 CRC attachment for E-AGCH

The E-RNTI is the E-DCH Radio Network Identifier defined in TS25.331. It is mapped such that $x_{id,1}$ corresponds to the MSB.

From the sequence of bits $x_{ag,1}, x_{ag,2}, \dots, x_{ag,w}$ a 16 bit CRC is calculated according to section 4.2.1.1 of TS25.212. That gives the sequence of bits c_1, c_2, \dots, c_{16} where

$$c_k = p_{im(17-k)} \quad k=1,2,\dots,16$$

This sequence of bits is then masked with $x_{id,1}, x_{id,2}, \dots, x_{id,16}$ and appended to the sequence of bits $x_{ag,1}, x_{ag,2}, \dots, x_{ag,w}$ to form the sequence of bits $y_1, y_2, \dots, y_{w+16}$ where

$$y_i = x_{ag,i} \quad i=1,2,\dots,w$$

$$y_i = (c_{i-w} + x_{id,i-w}) \bmod 2 \quad i=w+1,\dots,w+16$$

9.2.3.4 Channel coding for E-AGCH

Rate 1/3 convolutional coding, as described in Section 4.2.3.1 of TS25.212 is applied to the sequence of bits $y_1, y_2, \dots, y_{w+16}$, resulting in the sequence of bits $z_1, z_2, \dots, z_{3x(w+24)}$.

9.2.3.5 Rate matching for E-AGCH

Rate matching is applied to obtain the output sequence r_1, r_2, \dots, r_{60} from the input sequence $z_1, z_2, \dots, z_{3x(w+24)}$.

9.2.3.6 Physical channel mapping for E-AGCH

The E-AGCH sub-frame is described in section 8.2.3.

The sequence of bits r_1, r_2, \dots, r_{60} is mapped to the corresponding E-AGCH sub-frame. The bits r_k are mapped so that they are transmitted over the air in ascending order with respect to k .

It is FFS whether when the E-DCH TTI is equal to 10 ms the sequence of bits is transmitted in only one or in all the E-AGCH sub-frames of the E-AGCH radio frame.

9.3 E-DPCCH Coding and Multiplexing

The following information is transmitted by means of the E-DPCCH:

- Retransmission sequence number (RSN)
- E-TFCI information
- It is FFS whether a one-bit Rate Request shall be transmitted on E-DPCCH

9.3.1 Overview

The figure below illustrates the overall coding chain for E-DPCCH.

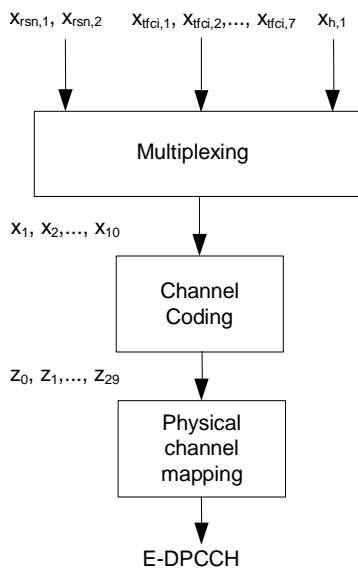

Figure 9.3.1: Coding chain for E-DPCCH

9.3.2 E-DPCCH information field mapping

9.3.2.1 Information field mapping of E-TFCI

The E-TFCI is mapped such that $x_{tfc,1}$ corresponds to the MSB.

9.3.2.2 Information field mapping of retransmission sequence number

To indicate the redundancy version (RV) of each HARQ transmission and to assist the Node B soft buffer management a two bit retransmission sequence number (RSN) is signalled from the UE to the Node B. The Node B can avoid soft buffer corruption by flushing the soft buffer associated to one HARQ process in case more than 3 consecutive

E-DPCCH transmissions on that HARQ process can not be decoded or the last received RSN is incompatible with the current one.

The RSN value for each initial transmission of an E-DCH transport block is 0. For the first retransmission the RSN value is 1, for the second retransmission the RSN value is 2 and for each further retransmission the RSN value is 3. The RSN is mapped such that $x_{rsn,1}$ corresponds to the MSB.

The applied E-DCH RV index specifying the used RV (s and r parameter) depends on the RSN, the used coding rate and if RSN=3 also from the TTIN (TTI number). For 10 ms TTI the TTI number is equal to the CFN, for 2 ms TTI

$$TTIN = 5 * CFN + \text{subframe number}$$

where the subframe number counts the five TTIs which are within a given CFN, starting from 0 for the first TTI to 4 for the last TTI. N_{ARQ} is the number of Hybrid ARQ processes.

Table 9.3.1: Relation between RSN value and E-DCH RV Index

RSN Value	Coding Rate <1/2	$\frac{1}{2} \leq$ Coding Rate
	E-DCH RV Index	E-DCH RV Index
0	0	0
1	2	3
2	0	2
3	$\lfloor \lfloor TTIN/N_{ARQ} \rfloor \bmod 2 \rfloor \times 2$	$\lfloor TTIN/N_{ARQ} \rfloor \bmod 4$

The UE shall use either

- an RV index as indicated in Table 9.3.1 and according to the RSN
- or, if signalled by higher layers only E-DCH RV index 0 independently of the RSN.

9.3.3 Multiplexing of E-DPCCH information

The E-TFCI information $x_{tfc,1}, x_{tfc,2}, \dots, x_{tfc,7}$, the retransmission sequence number $x_{rsn,1}, x_{rsn,2}$ and $x_{h,1}$ are multiplexed together. This gives a sequence of bits x_1, x_2, \dots, x_{10} where

$$x_k = x_{rsn,k} \quad k=1,2$$

$$x_k = x_{tfc,k-2} \quad k=3,4,\dots,9$$

$$x_k = x_{h,1} \quad k=10$$

9.3.4 Channel coding for E-DPCCH

Channel coding of the E-DPCCH is done using a sub-code of the second order Reed-Muller code. Coding is applied to the output x_1, x_2, \dots, x_{10} from the E-DPCCH multiplexing, resulting in:

$$z_i = \sum_{n=0}^9 (x_{n+1} \times M_{i,n}) \bmod 2 \quad i=0, 1, \dots, 29$$

The basis sequences are as described in 4.3.3 of TS25.212 for $i=0, 1, \dots, 29$.

9.3.5 Physical channel mapping for E-DPCCH

The E-DPCCH is described in TS25.211. The sequence of bits z_0, z_1, \dots, z_{29} output from the E-DPCCH channel coding is mapped to the corresponding E-DPCCH sub frame. The bits are mapped so that they are transmitted over the air in ascending order with respect to k . If the E-DCH TTI is equal to 10 ms the sequence of bits is transmitted in all the E-DPCCH sub frames of the E-DPCCH radio frame.

10 Spreading and Modulation

10.1 E-DPCCH/E-DPDCH

10.1.1 Spreading

Figure 10.1.1 illustrates the spreading operation for the E-DPDCHs and the E-DPCCH.

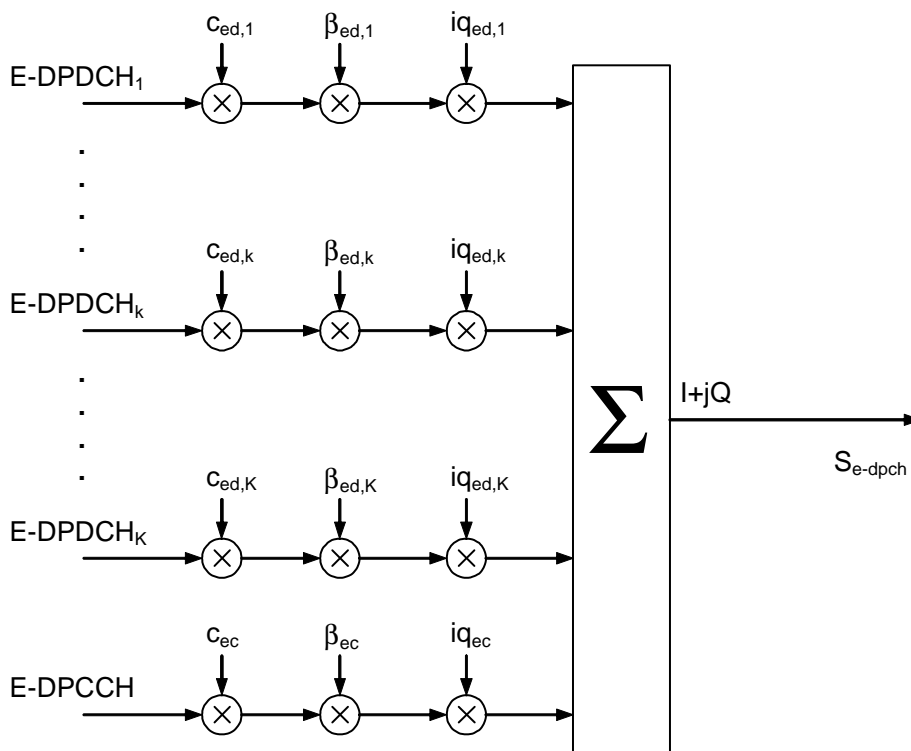

Figure 10.1.1: Spreading for E-DPDCH/E-DPCCH

The E-DPCCH shall be spread to the chip rate by the channelisation code c_{ec} . The k :th E-DPDCH, denominated E-DPDCH $_k$, shall be spread to the chip rate using channelisation code $c_{ed,k}$.

After channelisation, the real-valued spread E-DPCCH and E-DPDCH $_k$ signals shall respectively be weighted by gain factor β_{ec} and $\beta_{ed,k}$.

The value of β_{ec} shall be derived as specified in TS25.214 based on the power offset $\Delta_{E-DPCCH}$ signalled by higher layers. The relative power offsets $\Delta_{E-DPCCH}$ are quantized into amplitude ratios as specified in Table 1B of TS25.213.

The value of β_{ed} shall be computed based on the reference gain factors as specified in TS25.214. The reference gain factors are derived from the power offsets $\Delta_{E-DPDCH}$ signalled by higher layers. The relative power offsets $\Delta_{E-DPDCH}$ are quantized into amplitude ratios as specified in Table 1B.1 of TS25.213.

The value for $\beta_{ed,k}$ shall be set to $\sqrt{2} \times \beta_{ed}$ if the spreading factor for E-DPDCH $_k$ is 2 and to β_{ed} otherwise.

After weighting, the real-valued spread signals shall be mapped to the I branch or the Q branch according to the iq_{ec} value for the E-DPCCH and to $iq_{ed,k}$ for E-DPDCH $_k$ and summed together.

The E-DPCCH shall always be mapped to the I branch, i.e. $iq_{ec} = 1$.

The IQ branch mapping for the E-DPDCHs depends on $N_{max-dpdch}$ and on whether an HS-DSCH is configured for the UE; the IQ branch mapping shall be as specified in table 10.1.2.

Table 10.1.2: IQ branch mapping for E-DPDCH

$N_{\max\text{-dpdch}}$	HS-DSCH configured	E-DPDCH _k	$i_{q_{ed,k}}$
0	No/Yes	E-DPDCH ₁	1
		E-DPDCH ₂	j
		E-DPDCH ₃	1
		E-DPDCH ₄	j
1	No	E-DPDCH ₁	j
		E-DPDCH ₂	1
1	Yes	E-DPDCH ₁	1
		E-DPDCH ₂	j

NOTE: In case the UE transmits more than 2 E-DPDCHs, the UE then always transmits E-DPDCH₃ and E-DPDCH₄ simultaneously

The definition and quantization of the β_{ed} value is FFS. The β_{ed} value is relative to the DPCCH signal level.

10.1.2 Code allocation

10.1.2.1 Channelization code for E-DPCCH, E-DPDCH and HS-DPCCH

The E-DPCCH shall be spread with channelization code $c_{ec} = C_{ch,256,1}$.

E-DPDCH_k shall be spread with channelization code $c_{ed,k}$. The sequence $c_{ed,k}$ depends on $N_{\max\text{-dpdch}}$ and the spreading factor selected for the corresponding frame or sub-frame as specified in TS25.212; it shall be selected according to table 10.1.3.

Table 10.1.3: Channelization code for E-DPDCH

$N_{\max\text{-dpdch}}$	E-DPDCH _k	Channelization code $C_{ed,k}$
0	E-DPDCH ₁	$C_{ch,SF,SF/4}$ if $SF \geq 4$ $C_{ch,2,1}$ if $SF = 2$
	E-DPDCH ₂	$C_{ch,4,1}$ if $SF = 4$ $C_{ch,2,1}$ if $SF = 2$
	E-DPDCH ₃ E-DPDCH ₄	$C_{ch,4,1}$
1	E-DPDCH ₁	$C_{ch,SF,SF/2}$
	E-DPDCH ₂	$C_{ch,4,2}$ if $SF = 4$ $C_{ch,2,1}$ if $SF = 2$

NOTE: When more than one E-DPDCH is transmitted, the respective channelization codes used for E-DPDCH₁ and E-DPDCH₂ are always the same.

10.1.2.2 Channelisation code for HS-DPCCH

In the case of $N_{\max\text{-dpdch}}$ equals to 0 the HS-DPCCH shall be spread with code c_{hs} as specified in table 10.1.4. In the case of $N_{\max\text{-dpdch}} > 0$ the mapping will follow the same rule as specified already in release 5 version of the specifications.

Table 10.1.4: channelization code of HS-DPCCH

$N_{\max\text{-dpdch}}$ (as defined in subclause 10.1.2.1)	Channelization code c_{hs}
0	$C_{ch,256,33}$

10.1.2.3 Scrambling

E-DPDCH scrambling is the same as DPDCH scrambling.

10.2 E-HICH, E-RGCH and E-AGCH

For the E-HICH and the E-RGCH the input is a real valued symbol sequence as described in chapter 8.

For E-AGCH the input digits shall be mapped as for all channels except AICH, AP-AICH, CD/CA-ICH, E-HICH and E-RGCH,

For E-HICH and for E-RGCH, the spreading factor shall always be 128. In each cell, the E-RGCH and E-HICH assigned to a UE shall be configured with the same channelization code.

For E-AGCH, the spreading factor shall always be 256.

In each cell, the E-RGCH, E-HICH and E-AGCH assigned to a UE shall be configured with same scrambling code.

11 Physical Layer Procedures

11.1 Power control of E-AGCH/E-HICH/E-RGCH

The E-AGCH/E-HICH/E-RGCH power control is under the control of the node B.

11.2 E-DCH related procedures

The following physical layer parameters are signalled to the UE from higher layers:

- 1) E-HICH set to be monitored
- 2) E-RGCH set to be monitored

11.2.1 ACK/NACK detection

The physical layer in the UE shall detect ACK or NACK within the E-HICH set that is monitored by the UE in the subframes where ACK/NACK is transmitted by the UTRAN and deliver the ACK/NACK to the higher layers as follows:

- When a UE is not in soft handover, an ACK shall be delivered to the higher layers if a reliable ACK is detected by the physical layer in the UE, else a NACK shall be delivered to the higher layers.
- When a UE is in soft handover, multiple ACK/NACKs may be received in an E-DCH TTI from different cells in the active set. In some cases, the UE has the knowledge that some of the transmitted ACK/NACKs are the same. This is the case when the radio links are in the same radio link set. For these cases, ACK/NACKs from the same radio link set shall be soft combined into one ACK/NACK information and delivered to higher layers. If a radio link set contains only one radio link, the detection shall be done as specified above for the case where the UE is not in soft handover. For each radio link set containing multiple radio links, an ACK shall be delivered to the higher layers if a reliable ACK is detected by the physical layer in the UE after soft combining, else a NACK shall be delivered to the higher layers.

11.2.2 Relative grants detection

The physical layer in the UE shall detect relative grants within the E-RGCH set that is monitored by the UE and deliver the relative grants to the higher layers as follows:

- When a UE is not in soft handover, an UP shall be delivered to the higher layers if a reliable UP is detected by the physical layer in the UE, else a DOWN shall be delivered to the higher layers if a reliable DOWN is detected by the UE, else a HOLD shall be delivered to the higher layers.

- When a UE is in soft handover, multiple relative grants may be received in an E-DCH TTI from different cells in the E-DCH active set. In some cases, the UE has the knowledge that some of the transmitted relative grants are the same. This is the case when the radio links are in the same E-DCH Radio Link Set (serving or non serving). For these cases, relative grants from the same E-DCH Radio Link Set (serving or non serving) shall be soft combined into one relative grant information and delivered to higher layers. If a radio link set contains only one radio link, the detection shall be done as specified above for the case where the UE is not in soft handover. For each E-DCH radio link set containing multiple radio links, an UP shall be delivered to the higher layers if a reliable UP is detected by the physical layer in the UE after soft combining, else a DOWN shall be delivered to the higher layers if a reliable DOWN is detected by the UE after soft combining, else a HOLD shall be delivered to the higher layers.

11.2.3 E-DCH control timing

The control timing for the E-DCH is specified in chapter 6B.1 of TS25.214

11.3 Setting of the uplink DPCCH/E-DPCCH and E-DPDCH power difference

Setting of the uplink DPCCH/E-DPCCH and E-DPDCH power difference is specified in chapter 5.1.2.5B of TS25.214.

12 Physical Layer Measurements

13 UE Physical Layer Capabilities

- The E-DCH UE categories are defined in TS25.306.
- Support of 10 ms TTI is mandatory for all UEs.
- The maximum uplink DCH rate when E-DCH is configured for the UE is 64 kbps.

Annex A: Change history

Document history		
Date	Version	Comment
2004-05	V 0.0.0	Proposed skeleton for RAN1 #37.
2004-05	V 0.0.1	Updated based on agreements in RAN1#37. Modifications to the TR structure. R1-040631 to chapter 9.1. R1-040638 to chapter 5.1.
2004-06	V 0.0.2	R1-040799 with modifications to chapter 5.2 (Code multiplexing of DCH and E-DCH). R1-040803 Two TTI lengths to chapter 5.1, 10 ms TTI mandatory to chapter 13.
2004-07	V 0.0.3	Revised R1-040801 after email review to chapters 9.1.1 – 9.1.5.
2004-08	V 0.1.0	Changes approved and promoted V 0.0.3 to V 0.1.0 by RAN1#38.
2004-09	V 0.1.1	Editorial correction, text intended to chapter 13 was in the Annex A heading.
2004-09	V 0.2.0	V 0.1.1 Promoted to V 0.2.0 by RAN1#38bis.
2004-10	V 0.2.1	Changes agreed in text proposal email review after RAN1#38bis. Modified R1-041118 on E-DPCCH PhCH mapping to chapters 8.3.1 and 10.2.1 Modified R1-041235 on E-DPDCH PhCH structure to chapters 8.1.1 and 8.1.2 Modified R1-041236 on E-DPDCH multiplexing and spreading to 10.1.1 and 10.1.2. Modified R1-041237 on HARQ to 9.1.4. Modified R1-041244 on scheduling to chapters 7.1 and 7.2. Modified R1-041245 on DL control channels to 8.2, 9.2 and 10.2. Modified R1-041251 on to chapter 9.1.6 on needed number of PhCH bits.
2004-10	V 0.2.2	R1268 to chapter 6.2.1 as agreed in RAN1 email reflector. Editorial corrections to additions seen in V 0.2.1.
2004-10	V 0.2.3	DL control channel names: E-AGCH, E-RGCH, E-HICH edited to the document
2004-11	V 0.3.0	V 0.2.3 promoted to V 0.3.0 and changes approved by RAN1#39/RAN2#45 joint session
2004-12	V 0.3.1	Updated with RAN1 email approved CRs to TS25.201 and TS25.21x after RAN1#39: R1-041517, R1-041512, R1-041520, R1-041516, R1-041521, R1-041514.
2004-12	V 0.4.0	Editorial corrections
2004-12	V 1.0.0	Presented for RAN#26 for information. No changes to V 0.4.0.
2005-02	V 1.0.1	Aligned the I/Q mapping of Table 10.1.2 to CR25213-071r3 Added the definitions of serving/non-serving E-DCH RLS and serving E-DCH cell according to TS25.309 and corrected the 7.1 to be aligned with this and chapter 11.2.2. Corrected in 8.2.3 that E.-AGCH is received from a serving E-DCH cell, not from -RLS Align the terminology in tables 9.2.1 and 9.2.2
2005-02	V 1.1.0	V 1.0.1 Promoted to V 1.1.0 by RAN1#40.
2005-03	V 1.1.1	Updated with RAN1#40 agreements and deleted all the editor's notes
2005-03	V 2.0.0	V 1.1.1 promoted to V 2.0.0 and submitted for RAN#27 for approval.
Editor for 3GPP TR 25.808 is Karri Ranta-aho, Nokia Corporation.		
Tel. : +358 50 521 0651 Email : Karri.Ranta-aho@nokia.com		
This document is written in Microsoft Word 2000.		

Change history							
Date	TSG #	TSG Doc.	CR	Rev	Subject/Comment	Old	New

